

25G Long Reach Cable Link System Equalization Optimization

Geoff Zhang (Xilinx Inc.)

Yu Liao (Xilinx), Echo Ma (Luxshare-ICT),
Jinhua Chen (Luxshare-ICT), Geoff Zhang (Xilinx)



25G Long Reach Cable Link System Equalization Optimization

Geoff Zhang (Xilinx Inc.)

**Yu Liao (Xilinx), Echo Ma (Luxshare-ICT),
Jinhua Chen (Luxshare-ICT), Geoff Zhang (Xilinx)**

SPEAKERS

Geoff Zhang, SerDes Technology Group, Xilinx Inc.

geoff.zhang@xilinx.com

Geoff Zhang received his Ph.D. in 1997 in microwave engineering and signal processing from Iowa State University, Ames, Iowa. He joined Xilinx Inc. in 2013 as director of architecture and modeling in the SerDes Technology Group. Prior to joining Xilinx he has employment experiences with HiSilicon, Huawei Technologies, LSI, Agere Systems, Lucent Technologies, and Texas Instruments. His current interest is in transceiver architecture modeling and system level end-to-end simulations, both electrical and optical.

Outline

- TwinAx cable and its loss mechanisms
 - TwinAx cable structure and classifications
 - Loss mechanisms: PCB backplane vs. TwinAx cable
 - A 25G 5m 26AWG bulk cable loss decomposition
 - Crossover frequency comparison
- Brief overview of channel equalization
 - High speed link system and signal integrity
 - Channel analysis: time- vs. frequency domain
 - Common equalizers: TX FIR, RX CTLE and DFE
 - Equalization visualization for each equalizer
- TwinAx cable COM analysis example
 - COM computation example for a TwinAx cable
 - The computed COM is far less than the required 3dB
 - The COM CTLE is suboptimal for cable channels
- CTLE optimization for cable channels
 - Passive and active CTLE transfer functions
 - Necessity of a mid-frequency CTLE stage
 - Proposed CTLE = HFCTLE + MFCTLE + AGC
 - Equalization effect of the proposed CTLE
- Cable link time domain simulations
 - Simulation setup description and results
 - Eye diagrams and equalizer convergence
- Evaluation of a 100GBASE-CR4 system
 - 100GBASE-CR4 system setup description
 - 20nm 28G-LR IBIS-AMI model simulations
 - Lab measurement of the CR4 system
- Conclusions



TwinAx Cable and its Loss Mechanisms



TwinAx Cable Loss Mechanism

➤ TwinAx cable structure

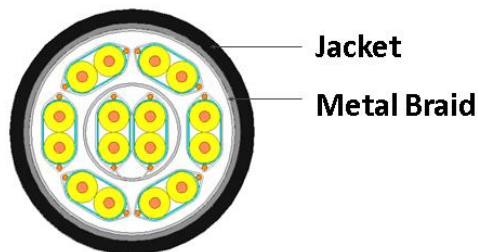

➤ RLGC representation

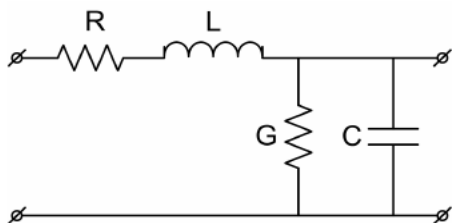

➤ Transmission constant

$$\gamma = \alpha + j\beta = \sqrt{(R + j\omega L)(G + j\omega C)} \quad (\dots \quad R \ll \omega L \text{ and } G \ll \omega C. \dots) \approx j\omega\sqrt{LC} \left[1 - \frac{j}{2} \left(\frac{R}{\omega L} + \frac{G}{\omega C} \right) \right]$$

$$\alpha \approx \frac{1}{2} \left(R \sqrt{\frac{C}{L}} + G \sqrt{\frac{L}{C}} \right) = \frac{1}{2} \left(\frac{R}{Z_0} + G Z_0 \right), \quad \beta = \omega\sqrt{LC}, \quad Z_0 = \sqrt{\frac{L}{C}}$$

➤ The skin-effect loss can be expressed as

$$\alpha_{Skin} = \frac{1}{2} \frac{R_{AC}}{Z_0}$$

➤ The dielectric loss can be expressed as

$$\alpha_{Dielectric} = \frac{1}{2} G_{AC} Z_0$$

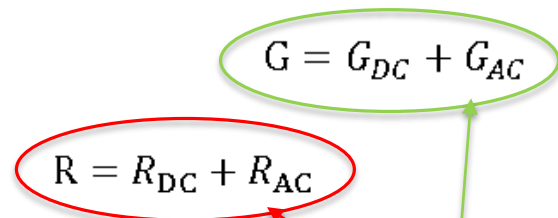

Three Types of TwinAx Differential Cables

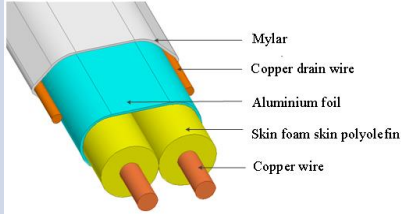
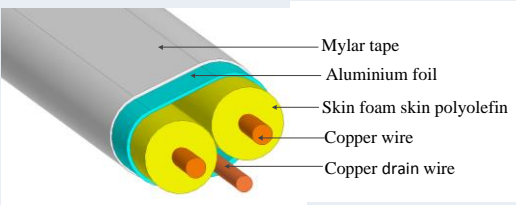
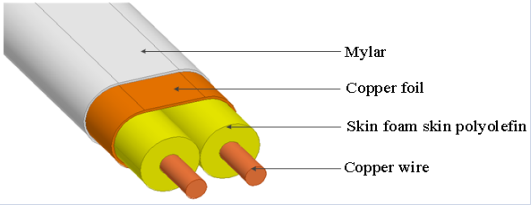
TwinAx Cable Types	High Frequency Performance	Production	Cost	
<p>Two drain wires</p>		<p>Middle</p>	<p>Easy</p>	<p>Middle</p>
<p>One drain wire</p>		<p>Poor</p>	<p>Middle</p>	<p>Low</p>
<p>Copper foil</p>		<p>Good</p>	<p>Hard</p>	<p>High</p>



Loss Decomposition for a 5m 26AWG Bulk Cable

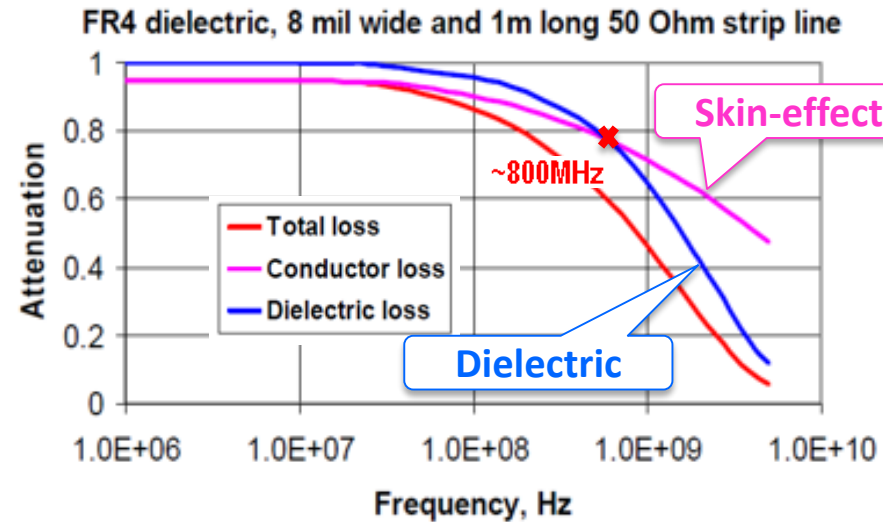
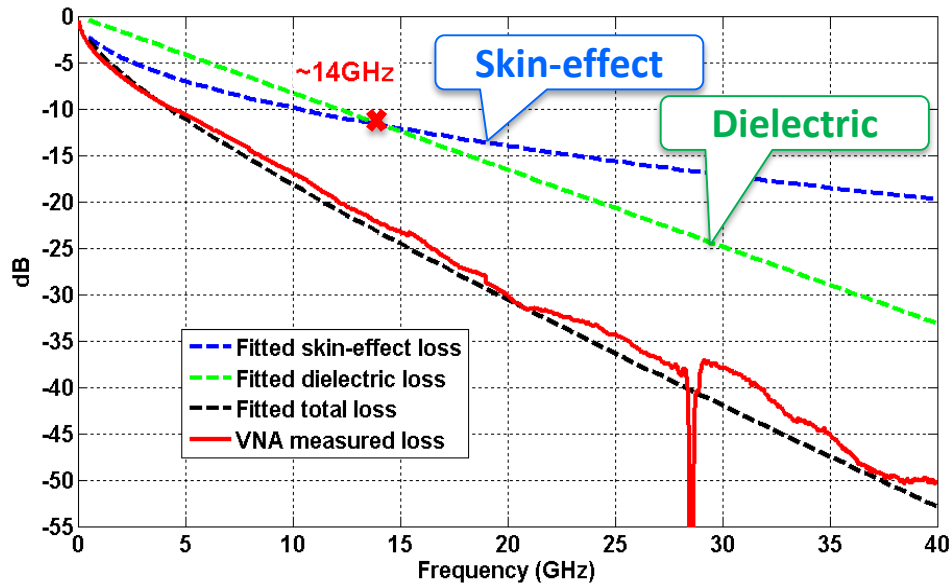

- Keysight PLTS is used to extract the RLGC model
- The crossover frequency is seen around 14GHz
- For the FR4 PCB the crossover is shown <1GHz

Measurement of a 5m 26AWG Bulk Cable

- The insertion loss (S_{DD21}) measured from the cable is shown in red
 - The cable channel also contains certain PCB trace loss as well as connector loss, as indicated by the setup below
- The insertion loss is plotted together with a PCB backplane channel made of Megtron-6 material (in blue)

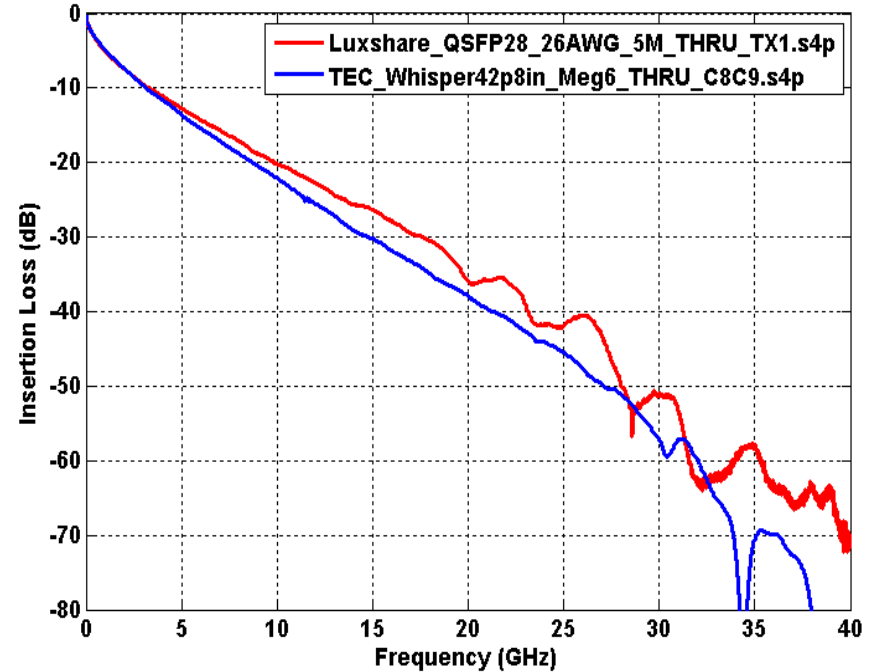

Brief Overview of Channel Equalization



A Typical High Speed Serial Link

- Data is transmitted from TX to RX through a channel composed of various components
- The channel can be as long as 1 meter for backplanes and 5 meters for cables
- Signal integrity suffers along the path and system performance margin reduces

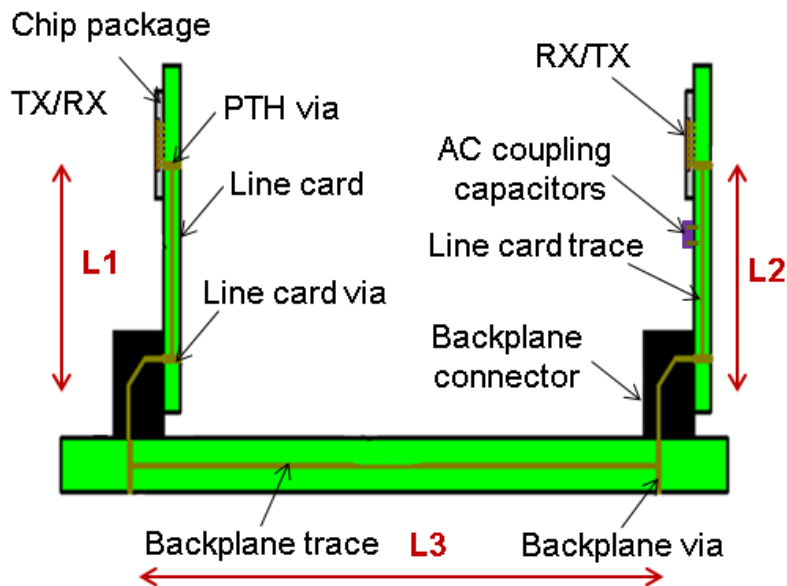

Time-Frequency Domain Conversion

Frequency domain (Insertion loss)

Loss, nulls, smooth/bumpiness, ...

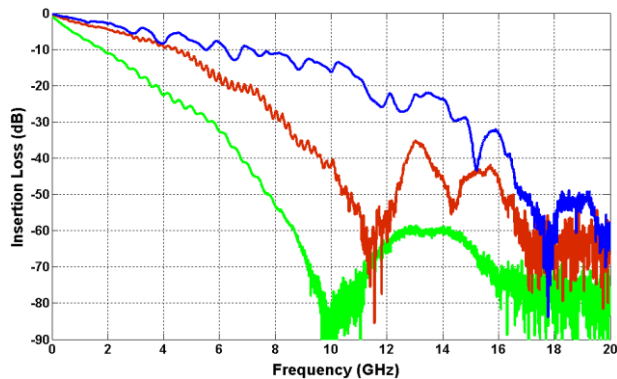

$$S_{21}(f) \Leftrightarrow h_{21}(t)$$

Time domain (Impulse response)

Delay, attenuation, spreading, ripples, ...

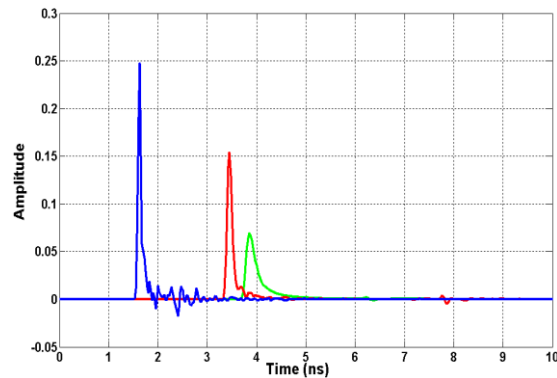

➤ The more accurate transfer function is

$$H(s) = \frac{V_2(s)}{V_S(s)} = \frac{S_{21}}{2} \left[\frac{(1 - \Gamma_S)(1 + \Gamma_L)}{(1 - S_{11}\Gamma_S)(1 - S_{22}\Gamma_L) - S_{12}S_{21}(\Gamma_S\Gamma_L)} \right]$$



Channel ISI and Equalization Techniques

- Inter-Symbol Interference (ISI) depicts the phenomenon in which energy in one bit leaks into neighboring bits on both sides

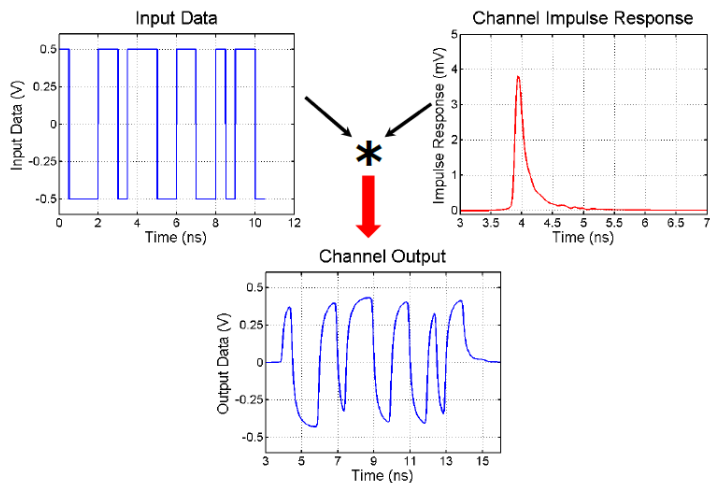

- Two commonly used techniques to mitigate ISI
 - *Equalization* is the most powerful and efficient method
 - *Signal modulation* is another optional solution, such as PAM4

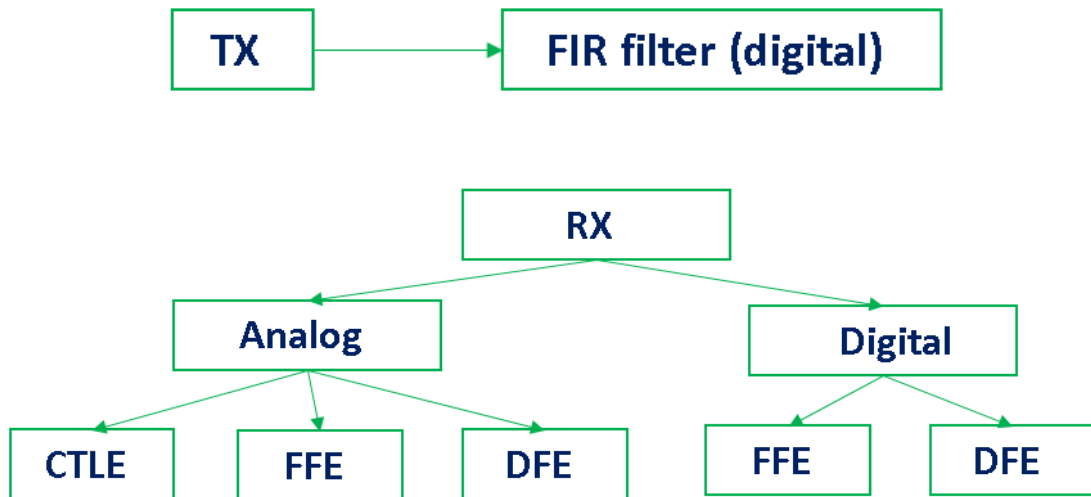

TX De-Emphasis via (3-tap) FIR Filtering

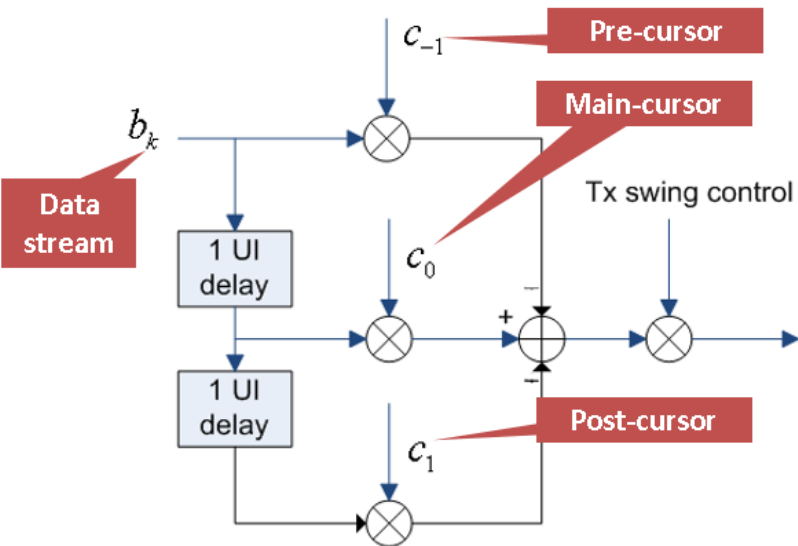

➤ FIR coefficients typically satisfy

- $C_{-1} + C_0 + C_1 = 1$
- $C_0 - C_{-1} - C_1 > 0$

➤ $C_{-1}=1, C_0=0, C_1=0 \rightarrow 0\text{dB de-emphasis}$

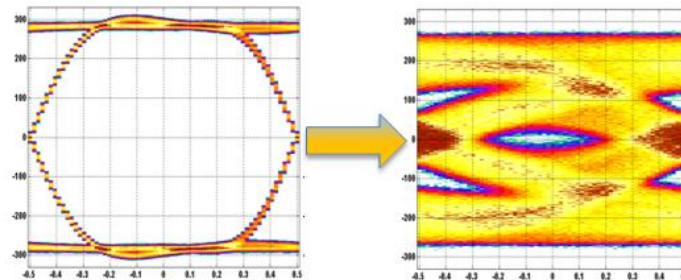

➤ $C_{-1}=0.075, C_0=0.75, C_1=0.175 \rightarrow 6\text{dB de-emphasis}$

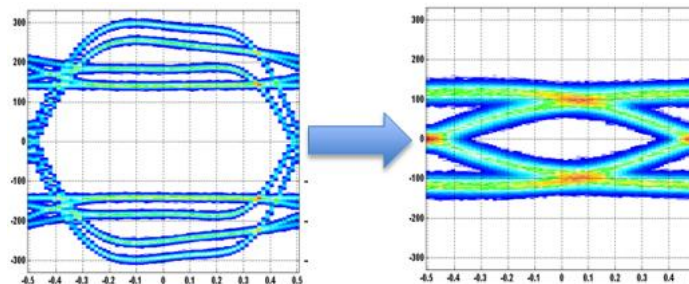

RX CTLE Equalization

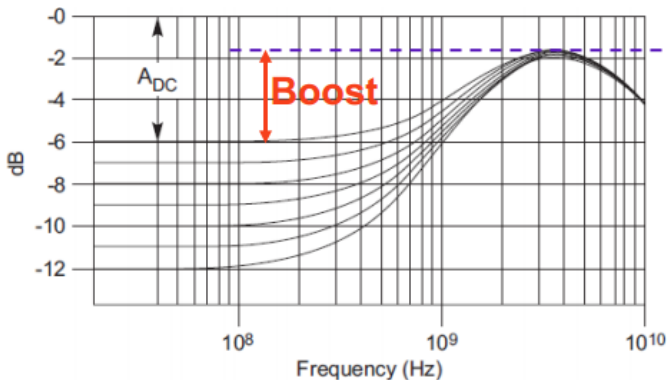

- The CTLE filters RX input signal by either boosting high frequency content attenuated in the channel or relatively attenuating low frequency content
 - It introduces zeros to offset the freq-dependent loss
 - CTLE will have the same effect on noise
- The CTLE is generally preceded/followed by AGC

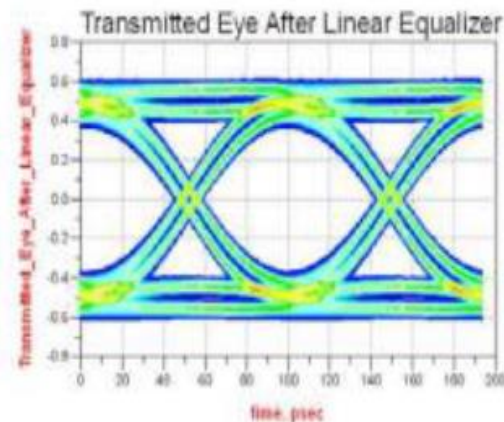
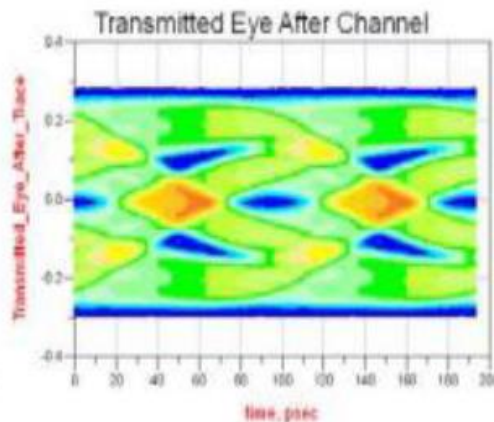
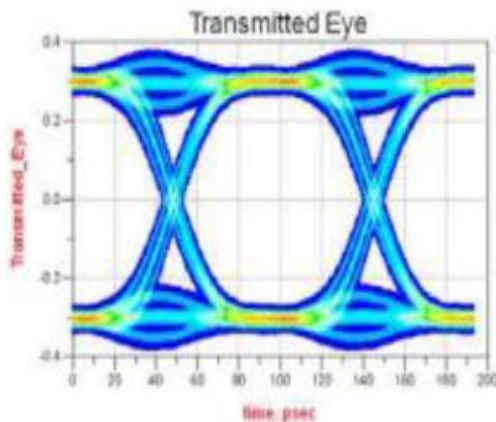

RX DFE for Removing Post-Cursor ISI

- DFE subtracts out channel impulse responses from the previous data bits to zero out post-cursor ISI contributions on the current bit

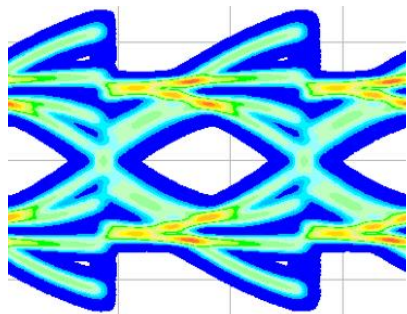
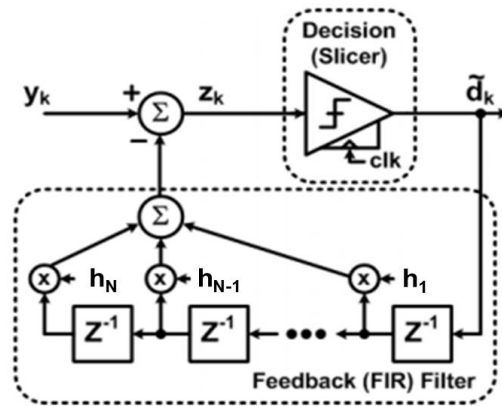
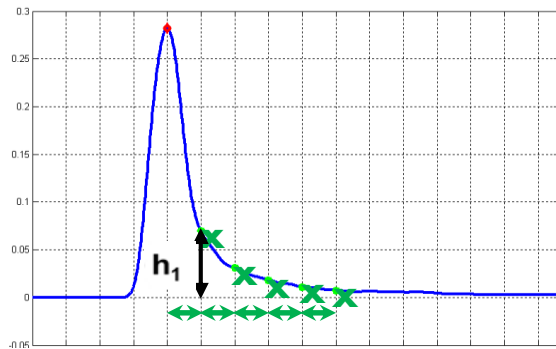

DFE tries to remove dominant positive ISI to open up the eye

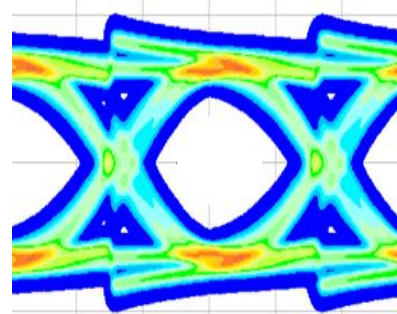

DFE needs to counteract dominant negative ISI to open up the eye



Equalization Goals

- The preliminary goal of channel equalization can be viewed as
 - In f-domain: to flatten the response within the frequency of interest
 - In t-domain: to remove pre- & post-cursor ISI and restrict energy

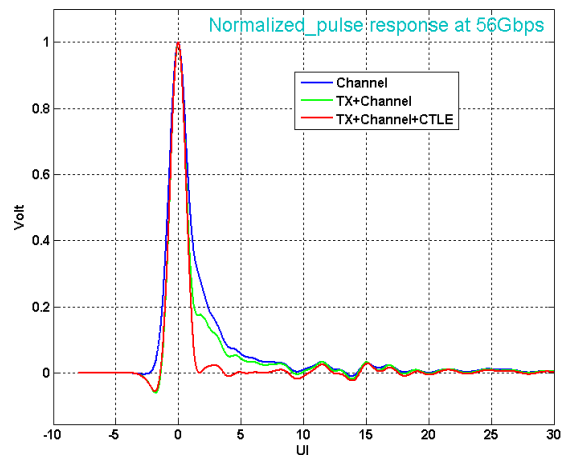
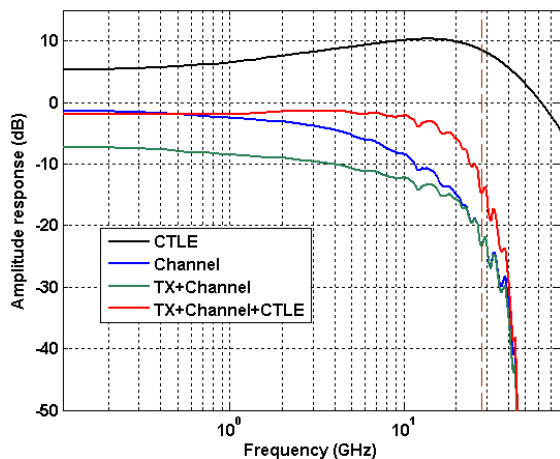

- Non-linear equalizers, such as DFE, do not directly fit into the above picture
- The ultimate goal is to ensure the system works within the BER target



COM Analysis Example of a TwinAx Cable



COM Evaluation Setup at 25.78125Gbps

- The changes made from COM default settings in the file “*config_com_ieee8023_93a=100GBASE-CR4.xls*” include:
 - A_v (TX differential peak output voltage, victim) = 0.5
 - A_{ne} (TX differential peak output voltage, far-end aggressor) = 0.5
 - A_{fe} (TX differential peak output voltage, near-end aggressor) = 0.5
 - DER_0 (target detector error ratio) is set to **1E-15**
 - N_b (number of DFE taps) is set to either 1 or 8
 - INC_PACKAGE is set to 0, as package models are already cascaded
- The IL, PSXT, ICR, and ILD are plotted

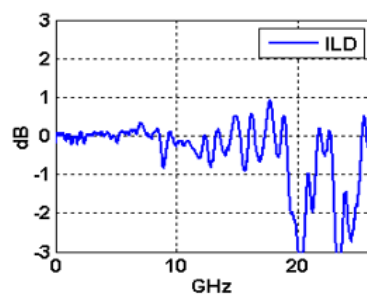
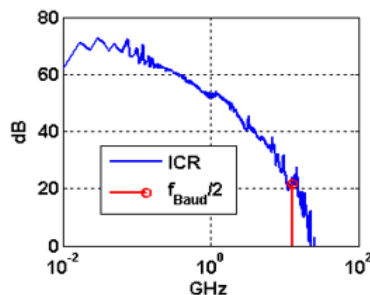
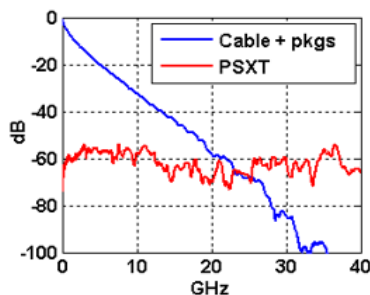
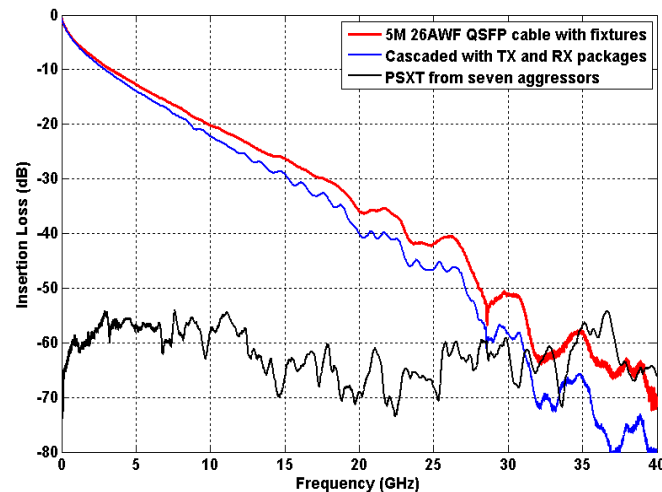

TwinAx Cable COM Evaluation

- COM defines CTLE for high-frequency peaking, f_b
- G_{DC} controls zero location, ranging from 0 to -12dB
- With 1-tap and 8-tap DFE, COM are both < 0dB

$$H_{CTLE}(f) = f_b \frac{j \cdot f + 0.25 \cdot f_b 10^{\frac{G_{DC}}{20}}}{(j \cdot f + 0.25 \cdot f_b) \cdot (j \cdot f + f_b)}$$

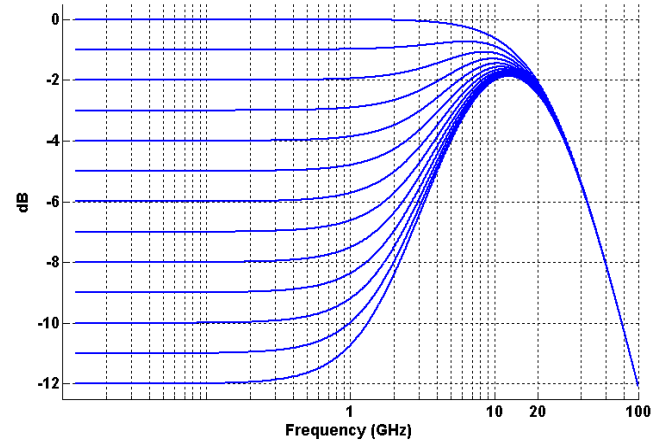

Input	N_b (DFE tap number)	1	8
Configured	TX FFE coefficients	[-0.14, 0.62, -0.24]	[-0.14, 0.62, -0.24]
Configured	G_{DC}	-12 dB	
Computed	COM	-2.148 dB	-0.755 dB
Estimated	BER	2.9e-10	1.8e-13



CTLE Optimization for Cable Channels



Continuous Time Linear Equalizer - CTLE

➤ Passive CTLE

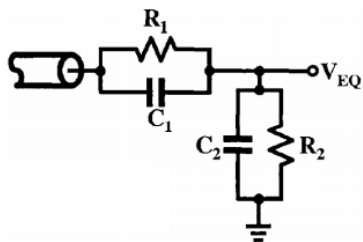

$$H(s) = \frac{R_2}{R_1 + R_2} \frac{1 + R_1 C_1 s}{1 + \frac{R_1 R_2}{R_1 + R_2} (C_1 + C_2) s}$$

$$\omega_z = \frac{1}{R_1 C_1}, \quad \omega_p = \frac{1}{\frac{R_1 R_2}{R_1 + R_2} (C_1 + C_2)}$$

$$\text{DC gain} = \frac{R_2}{R_1 + R_2}, \quad \text{HF gain} = \frac{C_1}{C_1 + C_2}$$

$$\text{Peaking} = \frac{\text{HF gain}}{\text{DC gain}} = \frac{\omega_p}{\omega_z} = \frac{R_1 + R_2}{R_2} \frac{C_1}{C_1 + C_2}$$

➤ Active CTLE

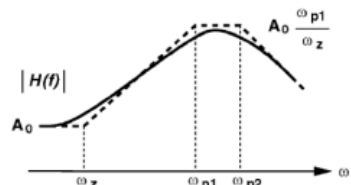
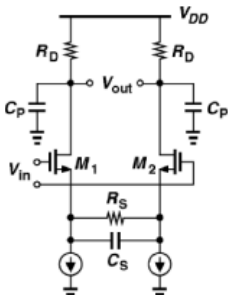

$$H(s) = \frac{g_m}{C_p} \frac{s + \frac{1}{R_S C_S}}{\left(s + \frac{1 + g_m R_S / 2}{R_S C_S} \right) \left(s + \frac{1}{R_D C_p} \right)}$$

$$\omega_{p2} = \frac{1}{R_D C_p}$$

$$\text{DC gain} = \frac{g_m R_D}{1 + g_m R_S / 2}, \quad \text{Ideal peak gain} = g_m R_D$$

$$\text{Ideal Peaking} = \frac{\text{Ideal peak gain}}{\text{DC gain}} = \frac{\omega_{p1}}{\omega_z} = 1 + g_m R_S / 2$$

➤ Active CTLE tuning

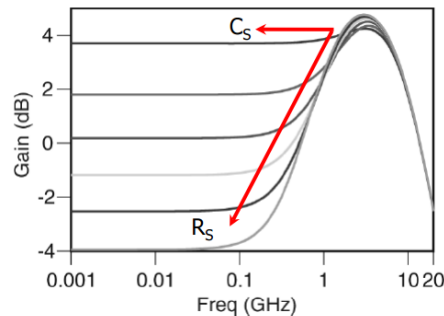

$$\omega_z = \frac{1}{R_S C_S}$$

$$\omega_{p1} = \frac{1 + g_m R_S / 2}{R_S C_S}$$

The Role of Mid-Frequency CTLE

- With just HFCTLE and TX FIR, the equalized link frequency-domain response will show unequalized profile in the mid-frequency range
- The added MFCTLE serves to compensate for the mid-frequency attenuation
- The MFCTLE is particularly necessary for cable channels whose skin-effect loss dominates up to much higher frequencies
 - The unequalized mid-frequency ISI shows as “long-tail” in the time domain, which might require many taps of DFE to effectively compensate

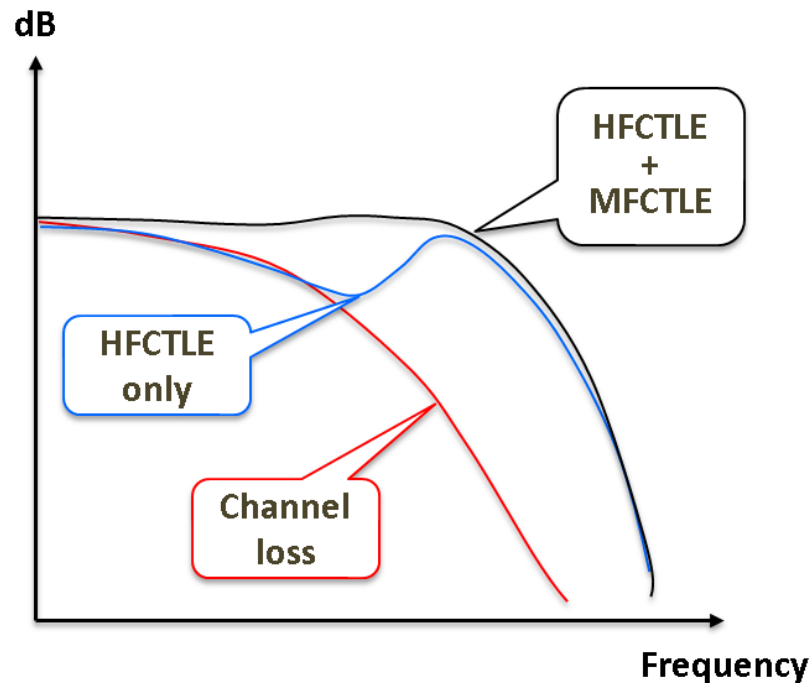

MFCTLE Design and CTLE Block Example

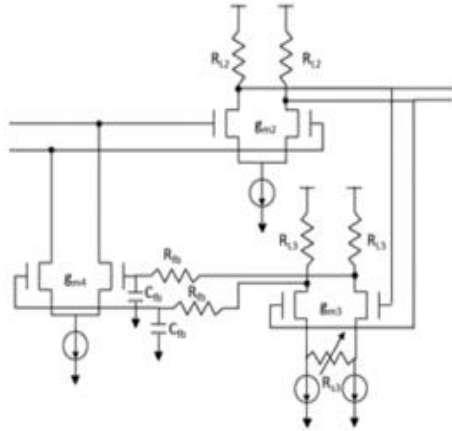

$$f_{p1} \approx f_z \left(1 + \frac{g_{m2} R_{L2} g_{m3} R_{L3} g_{m4} R_{L4}}{1 + g_{m3} R_{S3}} \right)$$

$$f_z \approx -\frac{1}{2\pi R_{\beta} C_{\beta}}$$

$$f_{p2} \approx -\frac{1}{2\pi R_{L2} C_{L2}}$$

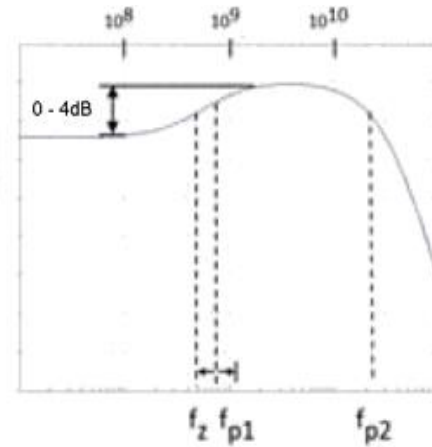

HFCTLE

MFCTLE

AGC

DFE
summer

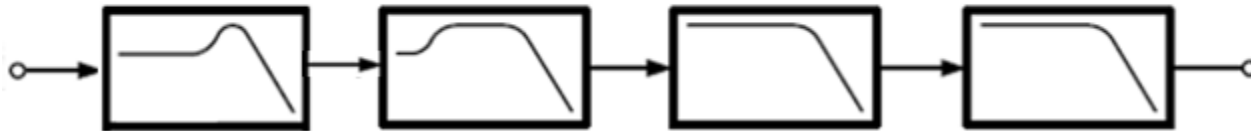

Proposed CTLE for QSFP Cables

- The proposed HFCTLE and MFCTLE are shown below in terms of magnitude transfer functions
 - The MFCTLE peaking is around 1/5th of that of HFCTLE
- The proposed HFCTLE is also plotted together with the COM defined CTLE for better comparison
- AGC is not shown but treated as a part of the CTLE block, as indicated on the previous page

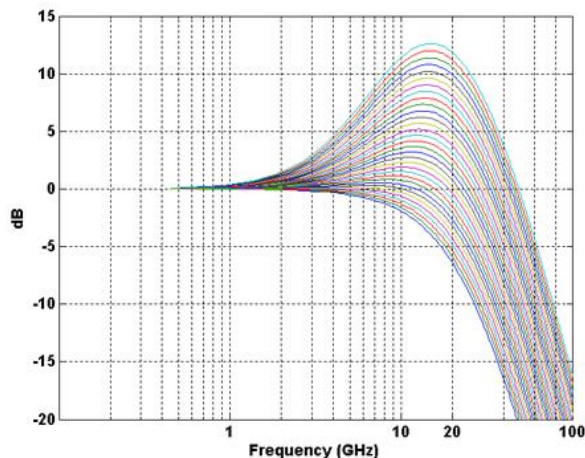

(a) HFCTLE

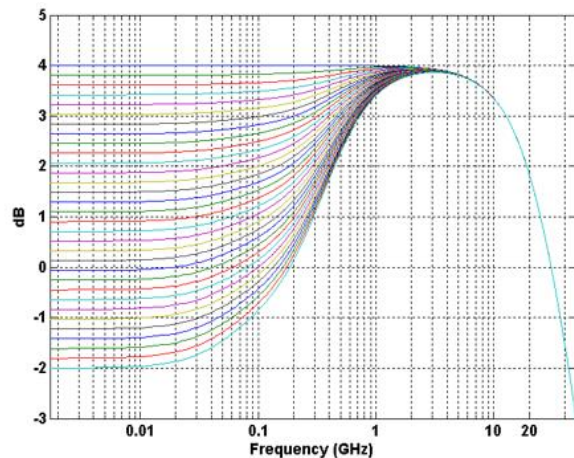

(b) MFCTLE

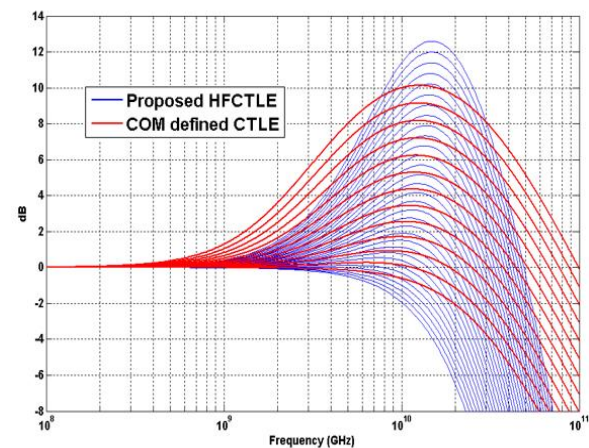

Equalization with COM-defined CTLE

- COM obtained the optimal setting for TX FFE $([-0.14, 0.62, -0.24])$ and for CTLE (GDC = -12dB)

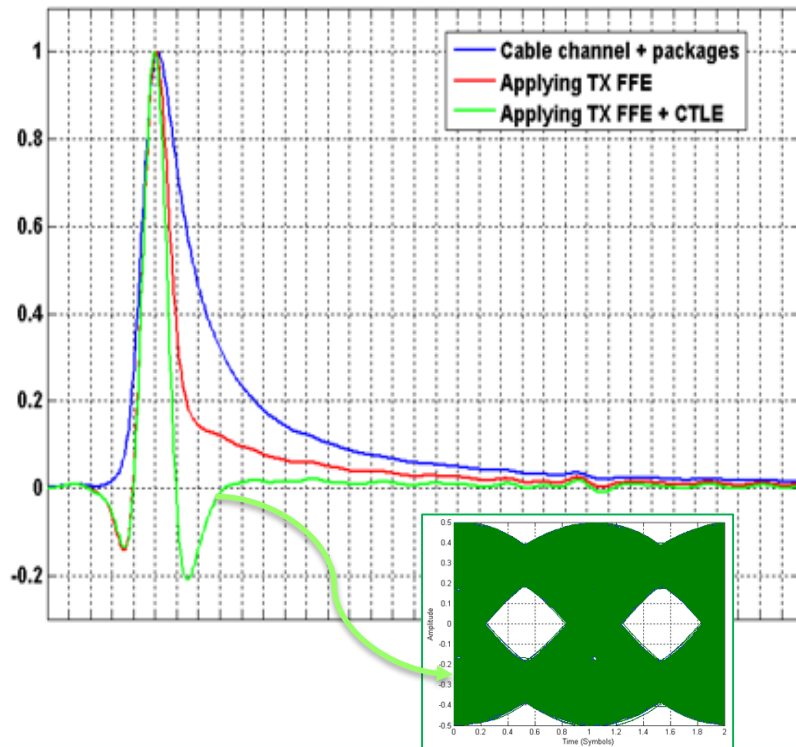
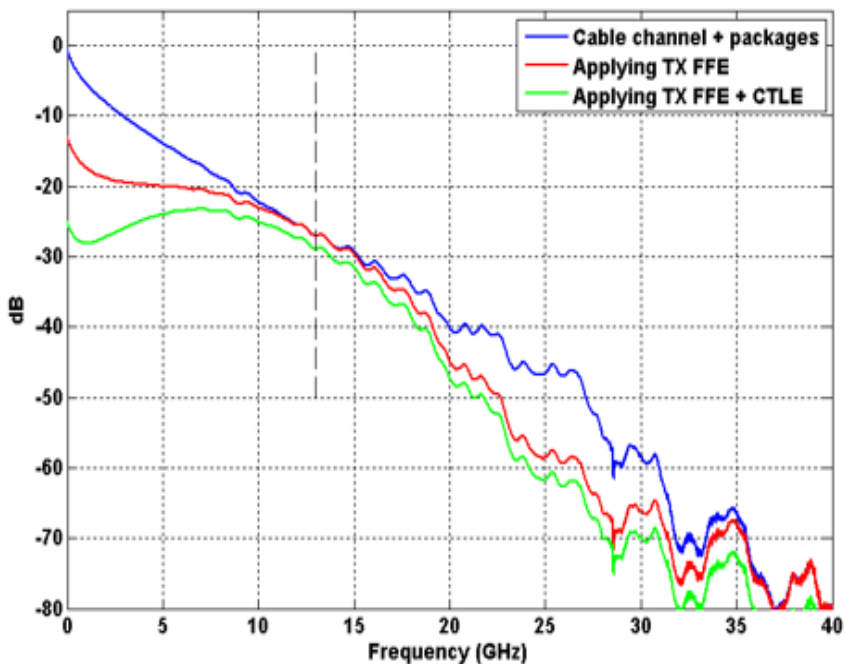

Equalization With the Proposed CTLE

- Apply TX FFE as $[-0.1375, 0.6375, -0.225]$, and set HFCTLE = 23 and MFCTLE = 20

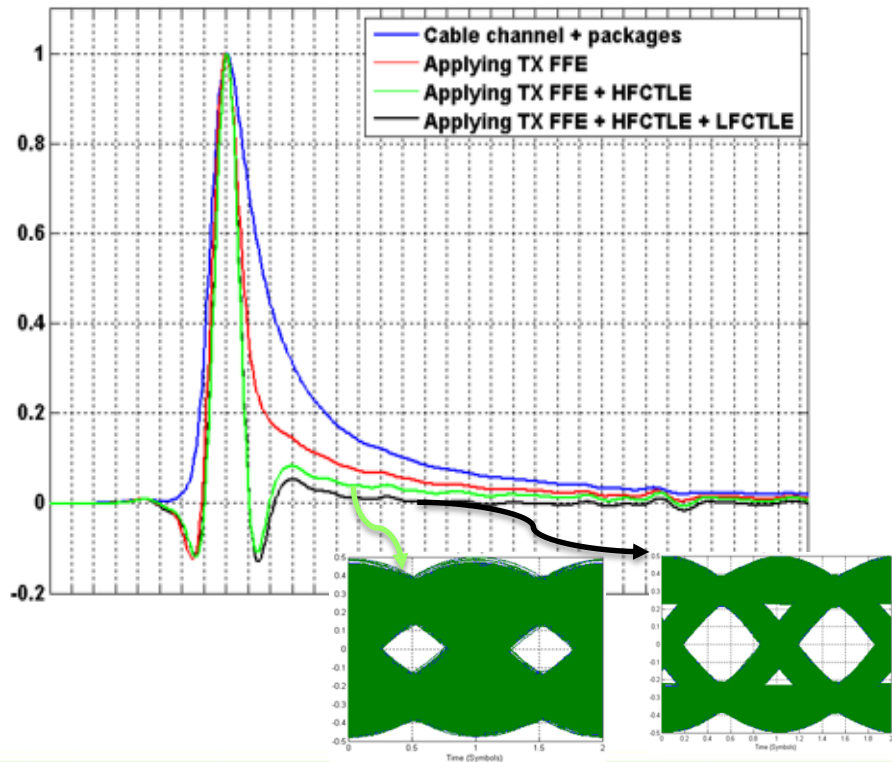
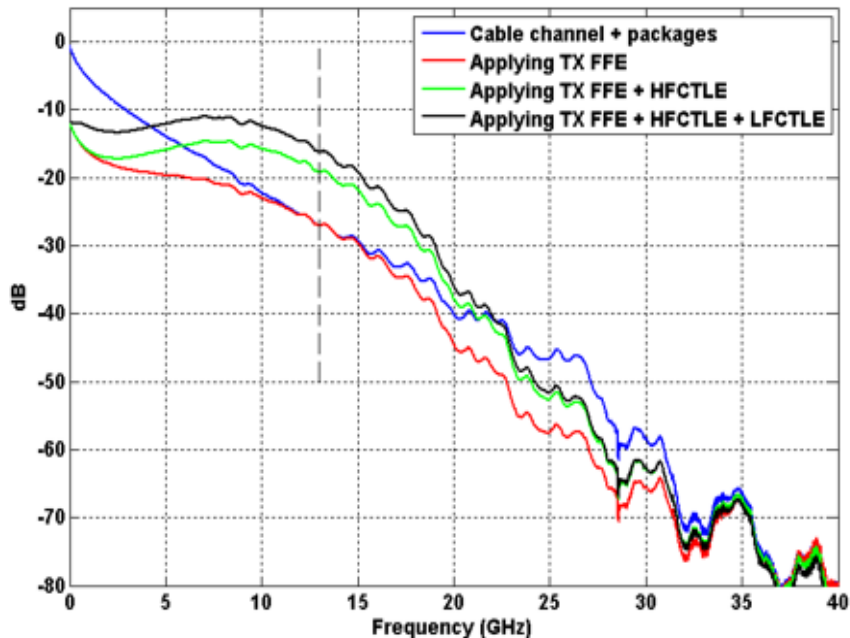

Comparison of Equalized Eyes

With COM CTLE

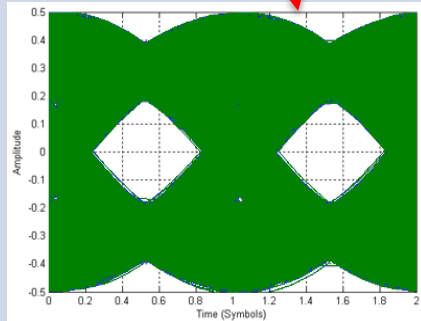
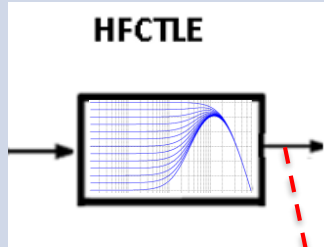

With Proposed CTLE

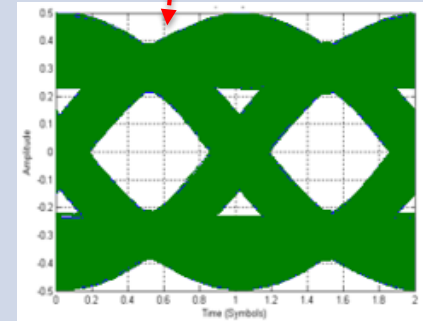
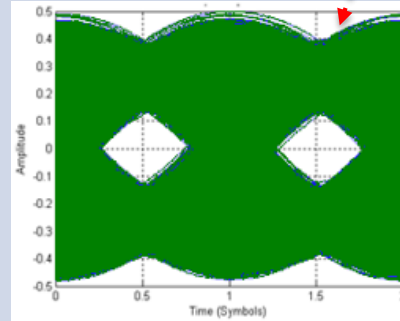
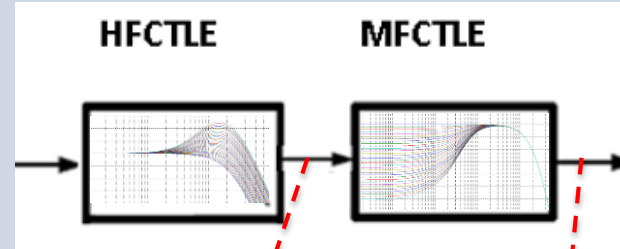

Cable Link Time Domain Simulations



Time Domain Simulations – Eye Diagrams

- The MFCTLE has exhibited tremendous impact on link performance
- HFCTLE is still the fundamental equalizer for the CTLE block
- DFE also helps enormously in removing residual post-cursor ISI

DFE tap = 1

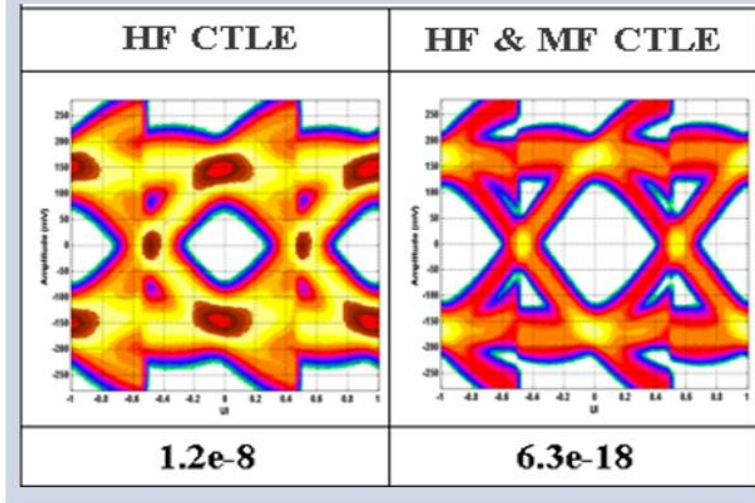

DFE tap = 8

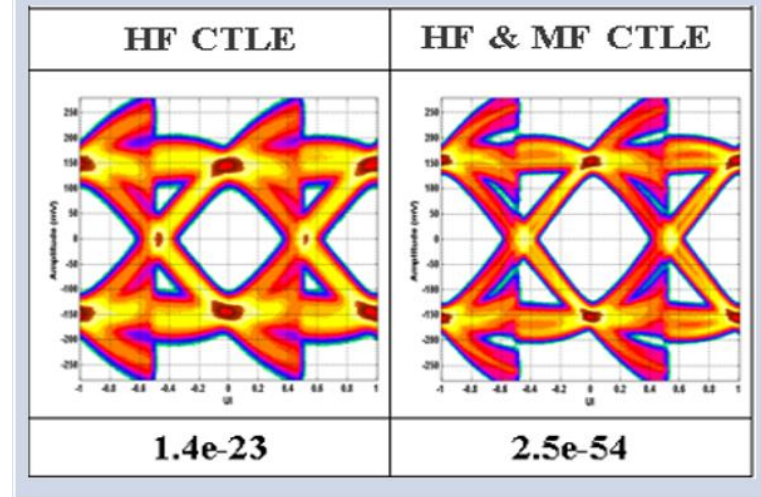

Time Domain Simulations - Convergence

➤ Convergences are plotted for the case in which DFE tap number = 1

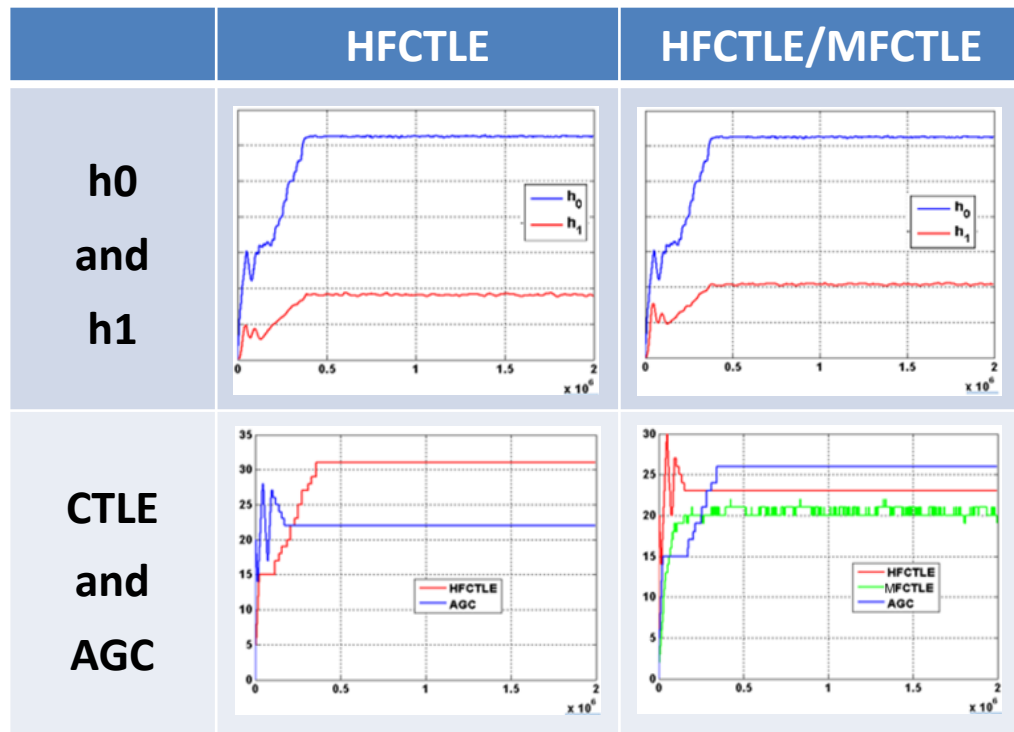

➤ It is seen that

- With MFCTLE, the demand on HFCTLE is relaxed
 - HFCTLE was maxed out at 31 without MFCTLE
 - HFCTLE = 23 when MFCTLE is added
- MFCTLE settled between 20 and 21



Evaluation of a 100GBASE-CR4 System



100GBASE-CR4 Setup

- The 100GBASE-CR4 intended topologies for cable applications

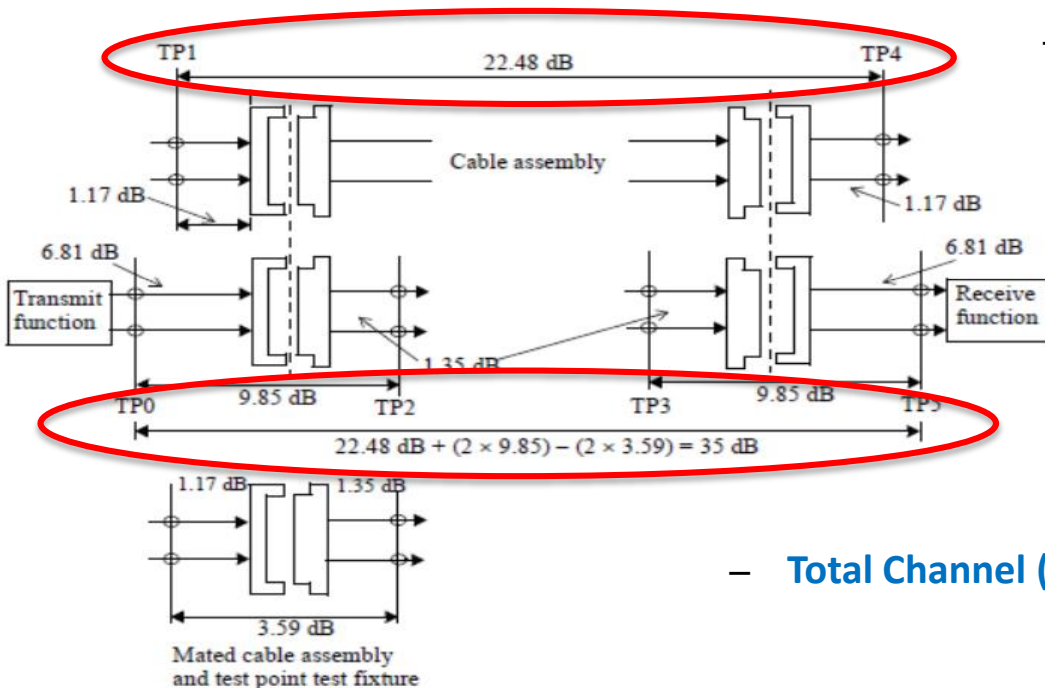

- Cable Assembly (TP1-TP4) $\leq 22.48\text{dB}$ for the 5m length

- Total Channel (TP0-TP5) $\leq 35\text{dB}$



100GBASE-CR4 Setup (Con't)

- The hardware setup emulating 100GBASE-CR4
 - The setup has a total insertion loss around 36dB, as seen from the B2B insertion loss

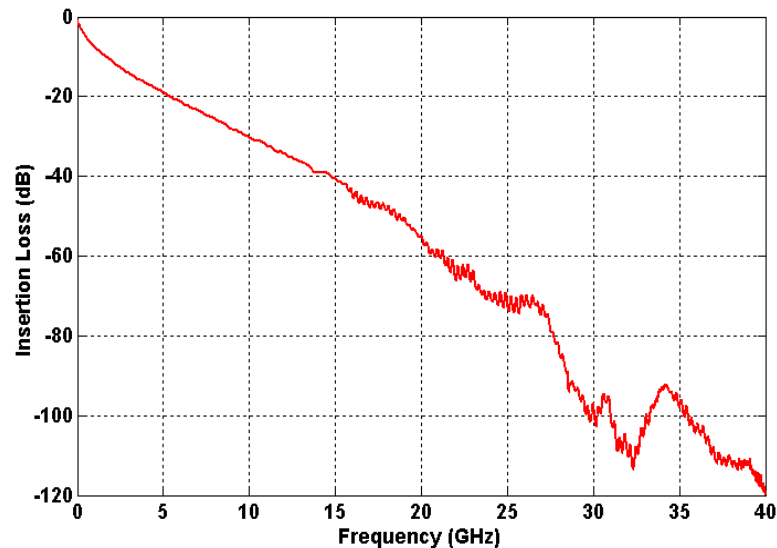
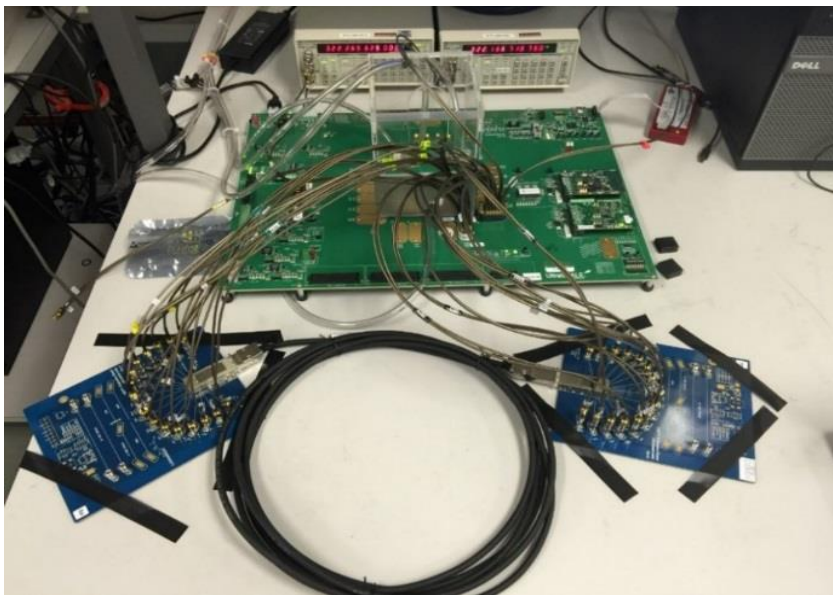

IBIS-AMI Model Simulations (1)

- The simulation is with the AMI model of a 20nm 28G-LR SerDes (with 15-tap DFE) in ADS
- Without the MFCTLE the link can only deliver $>1e-10$, thus requiring FEC to achieve $<1e-15$
- With the added MFCTLE the link can essentially work error-free

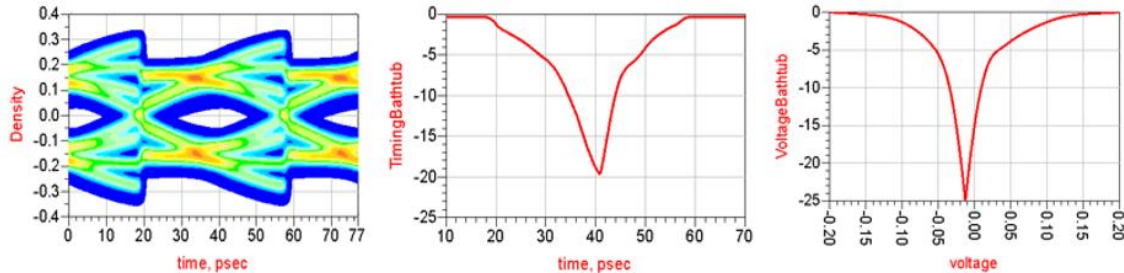

(a) MFCTLE is bypassed

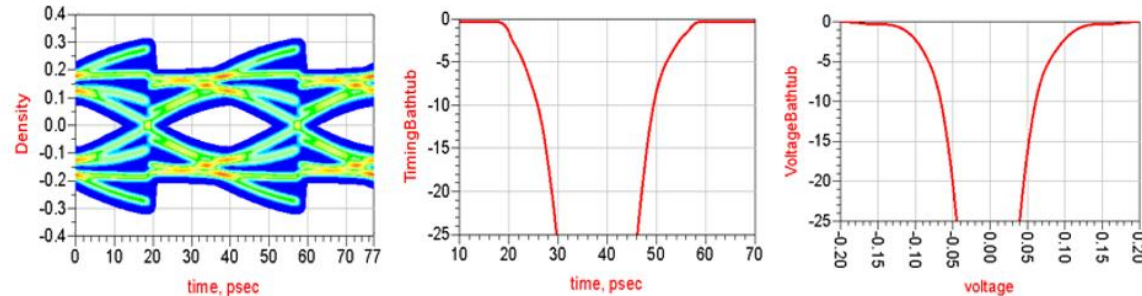

(b) MFCTLE is on



IBIS-AMI Model Simulations (2)

- The normalized DFE tap converged values indicated that
 - Residual ISI before the DFE is overall smaller when MFCTLE is included
 - After tap 8, DFE tap coefficients are essentially zero when MFCTLE is used

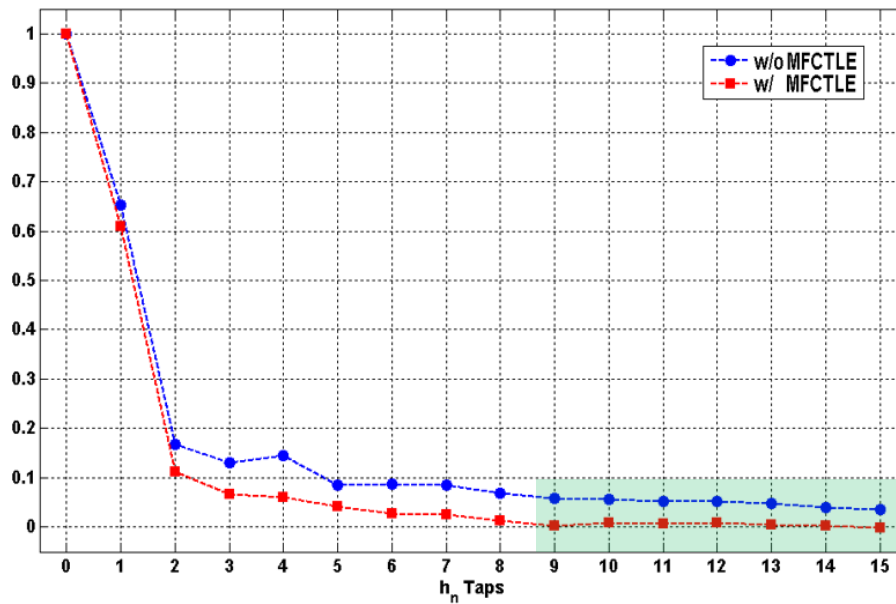

100GBASE-CR4 Setup Lab Measurement

- The lab test was carried out over 8 channels from 2 quads simultaneously
- The crosstalk, through connectors and inside packages, is naturally included in this setup
- The test showed that all 8 lanes worked error-free, without resorting to the FEC
- The on-die eye scans for all 8 channels are wide open

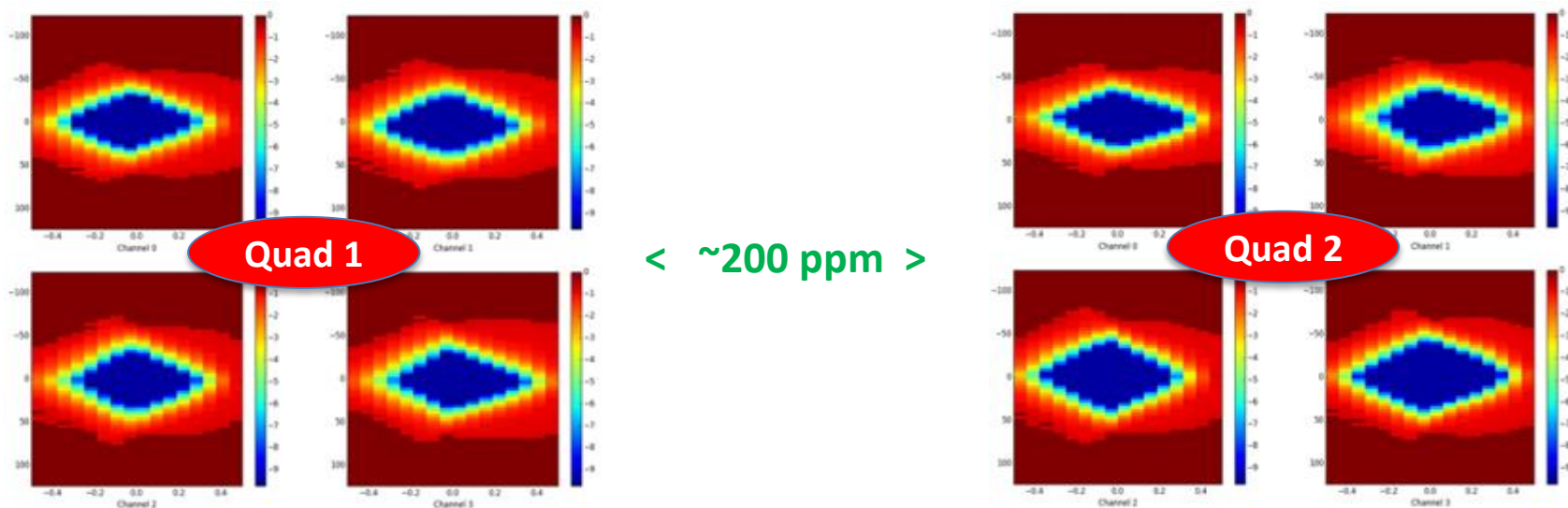

Conclusions

- It is shown that the MFCTLE is a great performance enhancer to the ubiquitous HFCTLE
 - The HFCTLE in itself plays a big role in equalizing the channel
- The MFCTLE is especially valuable for cable channels for the 25G application
 - The loss is more skin-effect dominated up to the Nyquist frequency
 - The HFCTLE alone would be suboptimal for the cable channel equalization
- Both simulations and lab measurements show that the SerDes with MFCTLE is capable of working with a CR4-compliant system
 - FEC can be optional for the guaranteed link margin over PVT
- Without the MFCTLE one would need to implement more complicated DFE to achieve the same link margin



Acknowledgment

The authors wish to thank *Sai Lalith Chaitanya Ambatipudi* for hardware setup and all the measurement data.

The authors also wish to thank *Hongtao Zhang* for the many insightful discussions.



References (1)

1. “High-speed Serial Interface”, High-Speed Circuits and Systems Lab, Yonsei University.
2. Samuel Palermo, “High-Speed Serial I/O Design for Channel Limited and Power-Constrained Systems”, Texas A&M University
3. Matthew Brown, et al, “The state of IEEE 802.3bj 100 Gb/s Backplane Ethernet”, DesignCon 2014.
4. David M Pozar, “Microwave Engineering”, Third Edition, 2006.
5. Edward P Sayre, Jinhua Chen, Micheal A. Baxter, “OC-48/2.5Gbps interconnect engineering design rules”, Design Con, 1999.
6. Vladimir Stojanović, “A systems approach to building modern high-speed links”, Integrated Systems Group, MIT.
7. Megha Shanbhag, et al, “COMPLIANCE CHECK FOR UPLOADED TEC CHANNELS Against IEEE802.3bj Draft1.2”, Nov. 2012, TE Connectivity.
8. Application Report, SLLA338–June 2013, “The Benefits of Using Linear Equalization in Backplane and Cable Applications”, Texas Instruments.



References (2)

9. Richard Mellitz, “ Various Topics for Computing Channel Operating Margin (COM) – 100 Gb/s Ethernet backplane and copper cable channel specification... A new signal integrity”, Intel, Feb. 2014.
10. Richard Mellitz, et al, “Channel Operating Margin (COM): Evolution of Channel Specifications for 25 Gbps and Beyond”, DesignCon 2013.
11. COM source code from “ran_com_3bj_3bm_01_1114.zip”.
12. Samir Parikh, et al, “A 32Gb/s Wireline Receiver with a low-frequency Equalizer, CTLE and 2-Tap DFE in 28nm CMOS”, ISSCC 2013.
13. Jafar Savoj, et al, “Design of High-Speed Wireline Transceivers for Backplane Communications in 28nm CMOS”, CICC, 2012 IEEE.
14. Yoshiyasu Doi et al, “Ultra-high-speed Interconnect Technology for Processor Communication”, Fujitsu Sci. Tech., Vol. 50, No 1, January 2014.
15. Application Note, “100 Gb/s Ethernet 100GBASE-CR4 Test Points and Test Fixtures”, Keysight.
16. IEEE Std 802.3bj-2014, AMENDMENT TO IEEE Std 802.3-2012: Ethernet.



Thank you!

QUESTIONS?

