

AXI Ethernet Lite MAC v3.0

LogiCORE IP Product Guide

Vivado Design Suite

PG135 November 2, 2021

Xilinx is creating an environment where employees, customers, and partners feel welcome and included. To that end, we're removing non-inclusive language from our products and related collateral. We've launched an internal initiative to remove language that could exclude people or reinforce historical biases, including terms embedded in our software and IPs. You may still find examples of non-inclusive language in our older products as we work to make these changes and align with evolving industry standards. Follow this [link](#) for more information.



Table of Contents

IP Facts

Chapter 1: Overview

Block Descriptions	6
Feature Summary	7
Unsupported Features	7
Licensing and Ordering	8

Chapter 2: Product Specification

Performance	9
Resource Utilization	9
Port Descriptions	12
Register Space	17

Chapter 3: Designing with the Core

Clocks	25
Resets	26
Programming Sequence	27
Management Data Input/Output (MDIO) Master Interface	32
Ethernet Protocol	33

Chapter 4: Design Flow Steps

Customizing and Generating the Core	41
Constraining the Core	44
Simulation	45
Synthesis and Implementation	45

Chapter 5: Example Design

Directory and File Contents	46
Example Design	48

Chapter 6: Test Bench

Simulating the Example Design	54
-------------------------------------	----

Appendix A: Upgrading

Migrating to the Vivado Design Suite	55
Upgrading in the Vivado Design Suite	55

Appendix B: Debugging

Finding Help on Xilinx.com	56
Vivado Design Suite Debug Feature	58
Hardware Debug	58

Appendix C: Additional Resources and Legal Notices

Xilinx Resources	59
Documentation Navigator and Design Hubs	59
References	60
Revision History	61
Please Read: Important Legal Notices	62

Introduction

The Xilinx® LogiCORE™ IP AXI Ethernet Lite Media Access Controller (MAC) core is designed to incorporate the applicable features described in the IEEE Std. 802.3 Media Independent Interface (MII) specification. It communicates with the processor using the AXI4 or AXI4-Lite interface.

The design provides a 10 Mb/s and 100 Mb/s (also known as Fast Ethernet) interface.

Features

- Parameterized AXI4 slave interface based on the AXI4 or AXI4-Lite specification for transmit and receive data dual port memory access
- Media Independent Interface (MII) for connection to external 10/100 Mb/s PHY transceivers
- Independent internal 2K byte TX and RX dual port memory for holding data for one packet
- Optional dual buffer memories, 4K byte ping-pong, for TX and RX
- Receive and Transmit Interrupts support
- Optional Management Data Input/Output (MDIO) interface for PHY access
- Internal loopback support

LogiCORE IP Facts Table	
Core Specifics	
Supported Devices ⁽¹⁾	Versal® ACAP, UltraScale+™ Families, UltraScale™ Architecture, Zynq®-7000 SoC, 7 Series
Supported User Interfaces	AXI4/AXI4-Lite
Resources	See Table 2-2 , Table 2-3 , and Table 2-4
Provided with Core	
Design Files	Encrypted RTL
Example Design	VHDL
Test Bench	VHDL
Constraints File	XDC
Simulation Model	Not Provided
Supported S/W Driver ⁽²⁾	Standalone and Linux
Tested Design Flows⁽³⁾	
Design Entry	Vivado® Design Suite Vivado
Simulation	For supported simulators, see the Xilinx Design Tools: Release Notes Guide .
Synthesis	Vivado Synthesis
Support	
Release Notes and Known Issues	Master Answer Record: 54389
All Vivado IP Change Logs	Master Vivado IP Change Logs: 72775
Xilinx Support web page	

Notes:

1. For a complete list of supported devices, see the Vivado IP catalog.
2. Standalone driver details can be found in the SDK directory (<install_directory>/SDK/<release>/data/embeddedsw/doc/xilinx_drivers.htm). Linux OS and driver support information is available from the [Xilinx Wiki page](#).
3. For the supported versions of the tools, see the [Xilinx Design Tools: Release Notes Guide](#).

Overview

The top-level block diagram of the AXI Ethernet Lite MAC is shown in [Figure 1-1](#).

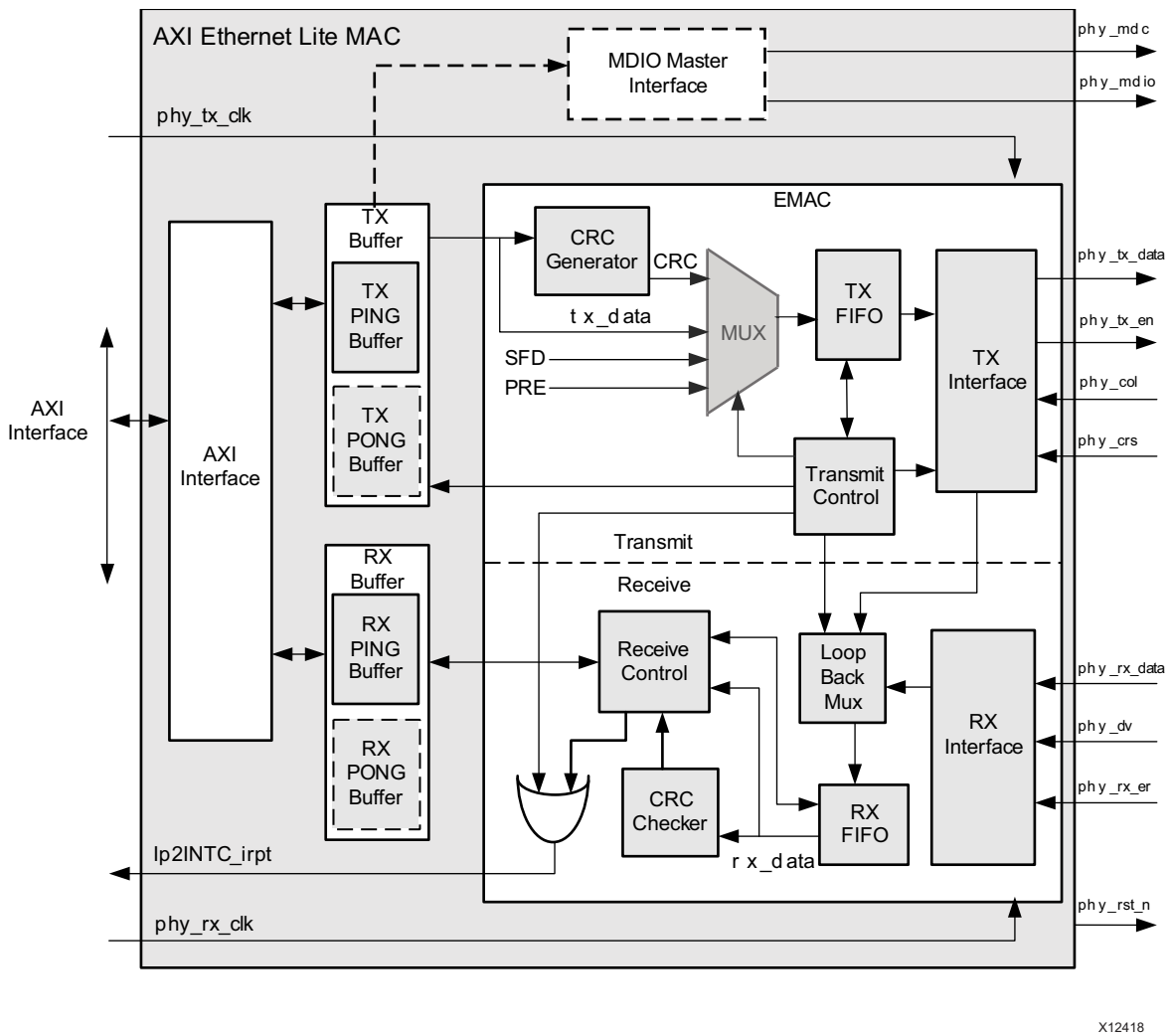

Figure 1-1: Block Diagram of the AXI Ethernet Lite MAC

X12418

Block Descriptions

AXI4 Interface

This block provides the AXI4 slave interface for register access and data transfer.

TX Buffer

The TX Buffer block consists of 2K byte dual port memory to hold transmit data for one complete frame and the transmit interface control registers. It also includes optional 2K byte dual port memory for the pong buffer based on the parameter **Number of Transmit Buffers**.

RX Buffer

The RX Buffer block consists of 2K dual port memory to hold receive data for one complete frame and the receive interface control register. It also includes optional 2K dual port memory for the pong buffer based on the parameter **Number of Receive Buffers**.

Transmit

This block consists of transmit logic, Cyclic Redundancy Check (CRC) generator module, transmit data MUX, TX First In First Out (FIFO) and the transmit interface module. The CRC generator module calculates the CRC for the frame to be transmitted. The transmit control MUX arranges this frame and sends the preamble, Start-of-Frame Delimiter (SFD), frame data, padding and CRC to the transmit FIFO in the required order. When the frame is transmitted to the PHY, this module generates a transmit interrupt and updates the transmit control register.

Receiver

This block consists of the RX interface, loopback control MUX, RX FIFO, CRC checker and Receive Control module. Receive data signals from the PHY are passed through the loopback control MUX and stored in the RX FIFO. If loopback is enabled, data on the TX lines is passed to the RX FIFO. The CRC checker module calculates the CRC of the received frame and if the correct CRC is found, receive control logic generates the frame receive interrupt.

MDIO Master Interface

The MDIO Master Interface block is included in the design if the parameter **Enable MII Management Module** is checked in the Vivado® Integrated Design Environment (IDE).

This module provides access to the PHY register for PHY management. The MDIO interface is described in [PHY Interface Signals in Chapter 2](#).

Feature Summary

- Parameterized AXI4 slave interface based on the AXI4 or AXI4-Lite specification for transmit and receive data dual port memory access
 - Media Independent Interface (MII) for connection to external 10/100 Mb/s PHY transceivers
 - Independent internal 2K byte TX and RX dual port memory for holding data for one packet
 - Optional dual buffer memories, 4K byte ping-pong, for TX and RX
 - Receive and Transmit Interrupts
 - Optional Management Data Input/Output (MDIO) interface for PHY access
 - Internal loopback support
 - Accepts messages addressed to its unicast address and the broadcast address.
-

Unsupported Features

- AXI data bus width greater than 32 bits
- AXI address bus width other than 32 bits
- AXI exclusive accesses
- AXI Trustzone
- AXI low-power interface
- AXI narrow transfers
- AXI FIXED, WRAP transactions
- AXI barrier transactions
- AXI debug transactions
- AXI user signals

Licensing and Ordering

This Xilinx® LogiCORE™ IP module is provided at no additional cost with the Xilinx Vivado Design Suite under the terms of the [Xilinx End User License](#). Information about this and other Xilinx LogiCORE IP modules is available at the [Xilinx Intellectual Property](#) page. For information about pricing and availability of other Xilinx LogiCORE IP modules and tools, contact your [local Xilinx sales representative](#).

Product Specification

Performance

The AXI Ethernet Lite core is characterized as per the benchmarking methodology described in the *Vivado Design Suite User Guide: Designing with IP* (UG896) [Ref 1]. [Table 2-1](#) shows the results of the characterization runs.

Resource Utilization

Table 2-1: Maximum Frequencies

Family	Speed Grade	F _{Max} (MHz)	
		AXI4	AXI4-Lite
Virtex-7	-1	200	180
Kintex-7		200	180
Artix-7		150	120
Virtex-7	-2	240	200
Kintex-7		240	200
Artix-7		180	140
Virtex-7	-3	280	220
Kintex-7		280	220
Artix-7		200	160

The AXI Ethernet Lite resource utilization for various parameter combinations measured with Virtex®-7 FPGA ([Table 2-2](#)), Kintex®-7 FPGA ([Table 2-3](#)), and Artix®-7 FPGA ([Table 2-4](#)) target device.

Note: Resource numbers for Zynq®-7000 SoC and UltraScale™ devices are expected to be similar to 7 series device numbers.

Table 2-2: Resource Estimations for Virtex-7 FPGAs

Full Duplex	Internal Loopback	Number of Receive Buffers	Number of Transfer Buffers	Enable MII	Enable Global Buffers	Number of Slices	Number of Flip-Flops	Number of LUTs
0	0	0	0	0	0	239	489	513
1	0	1	1	0	0	244	456	494
1	0	1	1	0	0	271	466	532
1	0	0	0	0	0	259	441	473
1	0	1	1	1	0	289	540	572
1	0	1	1	1	0	306	550	662
1	0	0	0	1	1	278	515	519
1	0	0	0	1	1	280	525	561
1	1	0	0	1	0	273	520	525

Table 2-3: Resource Estimations for Kintex-7 FPGAs

Full Duplex	Internal Loopback	Number of Receive Buffers	Number of Transfer Buffers	Enable MII	Enable Global Buffers	Number of Slices	Number of Flip-Flops	Number of LUTs
0	0	0	0	0	0	256	489	500
1	0	1	1	0	0	231	456	494
1	0	1	1	0	0	270	466	534
1	0	0	0	0	0	253	441	472
1	0	1	1	1	0	297	540	572
1	0	1	1	1	0	301	550	608
1	0	0	0	1	0	268	515	517

Table 2-3: Resource Estimations for Kintex-7 FPGAs (Cont'd)

Full Duplex	Internal Loopback	Number of Receive Buffers	Number of Transfer Buffers	Enable MII	Enable Global Buffers	Number of Slices	Number of Flip-Flops	Number of LUTs
1	0	0	0	1	1	273	525	562
1	1	0	0	1	0	269	520	532

Table 2-4: Resource Estimations for Artix-7 FPGAs

Full Duplex	Internal Loopback	Number of Receive Buffers	Number of Transfer Buffers	Enable MII	Enable Global Buffers	Number of Slices	Number of Flip-Flops	Number of LUTs
0	0	0	0	0	0	264	489	518
1	0	1	1	0	0	261	456	516
1	0	1	1	0	0	250	467	500
1	0	0	0	0	0	245	441	492
1	0	1	1	1	0	301	540	607
1	0	1	1	1	0	321	550	636
1	0	0	0	1	0	281	515	542
1	0	0	0	1	1	287	525	580
1	1	0	0	1	0	292	520	547

Port Descriptions

I/O Signals

The AXI Ethernet Lite MAC I/O signals are listed and described in [Table 2-5](#).

Table 2-5: I/O Signal Descriptions

Signal Name	Interface	I/O	Initial State	Description
System Signals				
s_axi_aclk	System	I	-	AXI4 clock (Processor clock domain)
s_axi_aresetn	System	I	-	AXI4 reset, active-Low
ip2intc_irpt	System	O	0	Edge rising interrupt
AXI4 Write Address Channel Signals				
s_axi*	S_AXI	-	-	See Appendix A of the <i>Vivado AXI Reference Guide</i> (UG1037) [Ref 2] for the description of AXI4 Signals.
AXI Ethernet Lite MAC Interface Signals				
phy_tx_clk	PHY	I	-	Ethernet transmit clock input from PHY
phy_rx_clk	PHY	I	-	Ethernet receive clock input from PHY
phy_rx_data[3:0]	PHY	I	-	Ethernet receive data. Input from Ethernet PHY.
phy_tx_data[3:0]	PHY	O	0	Ethernet transmit data. Output to Ethernet PHY.
phy_dv	PHY	I	-	Ethernet receive data valid. Input from Ethernet PHY.
phy_rx_er	PHY	I	-	Ethernet receive error. Input from Ethernet PHY.
phy_tx_en	PHY	O	0	Ethernet transmit enable. Output to Ethernet PHY.
phy_crs	PHY	I	-	Ethernet carrier sense input from Ethernet PHY
phy_col	PHY	I	-	Ethernet collision input from Ethernet PHY
phy_rst_n	PHY	O	-	PHY reset, active-Low
phy_mdc ⁽¹⁾	PHY	O	0	Ethernet to PHY MII Management clock
phy_mdio_i ⁽¹⁾	PHY	I	-	PHY MDIO data input from 3-state buffer
phy_mdio_o ⁽¹⁾	PHY	O	0	PHY MDIO data output to 3-state buffer
phy_mdio_t ⁽¹⁾	PHY	O	0	PHY MDIO data output enable to 3-state buffer

Notes:

1. This port is unused when **Enable MII Management Module** is disabled in the Vivado IDE. Output has default assignment.
2. The signal phy_mdio is a bidirectional port. The insertion of the 3-state buffer is automatically done by the Vivado IP integrator tool. You do not need to connect phy_mdio_i, phy_mdio_o and phy_mdio_t signals manually when using IP in IP integrator.

PHY Interface Signals

phy_rst_n

Many PHY devices require that they be held in reset for some period after the power-up sequence. The **phy_rst_n** signal is an active-Low reset that is tied directly to the AXI reset signal (**s_axi_aresetn**). This output signal can be connected to the active-Low reset input of a PHY device.

phy_tx_en

The AXI Ethernet Lite MAC uses the Transmit Enable signal (**phy_tx_en**) to indicate to the PHY that it is providing nibbles at the MII interface for transmission. It is asserted synchronously to **phy_tx_clk** with the first nibble of the preamble and remains asserted while all nibbles are transmitted. [Figure 2-1](#) shows the **phy_tx_en** timing during a transmission with no collisions.

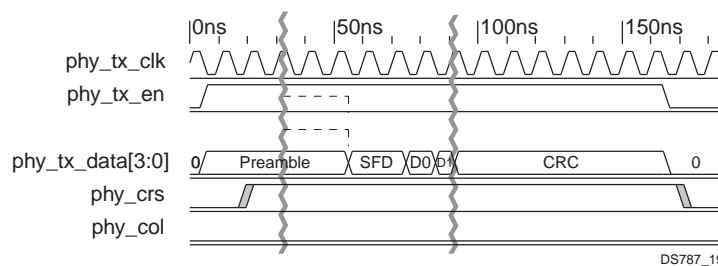

Figure 2-1: Transmission with No Collision

phy_tx_data(3:0)

The AXI Ethernet Lite MAC drives the Transmit Data bus **phy_tx_data(3:0)** synchronously to **phy_tx_clk**. The signal **phy_tx_data(0)** is the least significant bit. The PHY transmits the value of **phy_tx_data** on every clock cycle that **phy_tx_en** is asserted. The order of the bits, nibbles, and bytes for transmit and receive are shown in [Figure 2-2](#).

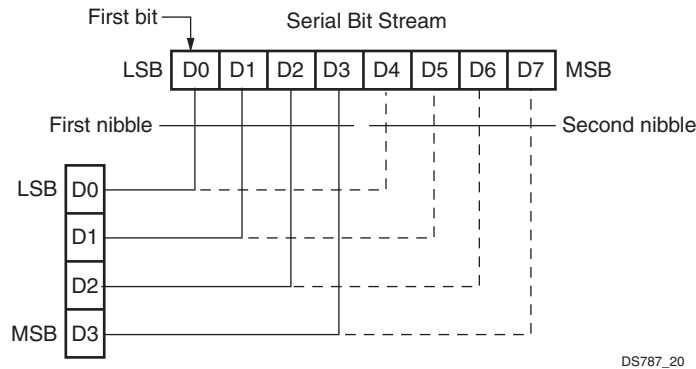

Figure 2-2: Byte/Nibble Transmit and Receive Order

phy_dv

The PHY drives the Receive Data Valid (**phy_dv**) signal to indicate that the PHY is driving recovered and decoded nibbles on the **phy_rx_data (3:0)** bus and that the data on **phy_rx_data (3:0)** is synchronous to **phy_rx_clk**. The signal **phy_dv** is driven synchronously to **phy_rx_clk**. The signal **phy_dv** remains asserted continuously from the first recovered nibble of the frame through the final recovered nibble.

For a received frame to be correctly received by the AXI Ethernet Lite MAC, **phy_dv** must encompass the frame, starting no later than the Start-of-Frame Delimiter (SFD) and excluding any End-of-Frame delimiter. Figure 2-3 shows the behavior of **phy_dv** during frame reception.

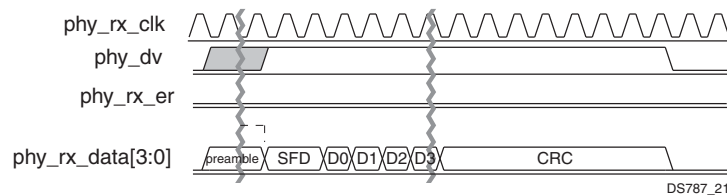

Figure 2-3: Receive with No Errors

phy_rx_data(3:0)

The PHY drives the Receive Data bus **phy_rx_data (3:0)** synchronously to **phy_rx_clk**. The signal **phy_rx_data (3:0)** contains recovered data for each **phy_rx_clk** period in which **phy_dv** is asserted. The signal **phy_rx_data (0)** is the least significant bit. The AXI Ethernet Lite MAC must not be affected by **phy_rx_data (3:0)** while **phy_dv** is deasserted.

The AXI Ethernet Lite MAC should ignore a special condition that occurs while `phy_dv` is deasserted; the PHY can provide a False Carrier indication by asserting the `phy_rx_er` signal while driving the value 1110 onto `phy_rx_data(3:0)`.

phy_rx_er

The PHY drives the Receive Error signal (`phy_rx_er`) synchronously to `phy_rx_clk`. The PHY drives `phy_rx_er` for one or more `phy_rx_clk` periods to indicate that an error (such as a coding error or any error that the PHY is capable of detecting) was detected somewhere in the frame presently being transferred from the PHY to the AXI Ethernet Lite MAC.

The signal `phy_rx_er` should have no effect on the AXI Ethernet Lite MAC while `phy_dv` is deasserted. Figure 2-4 shows the behavior of `phy_rx_er` during frame reception with errors.

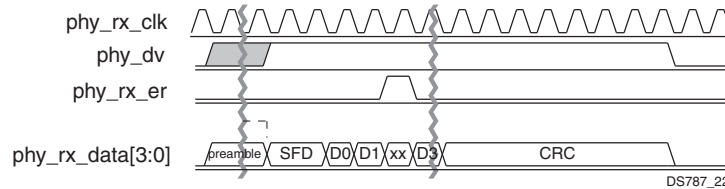

Figure 2-4: Receive with Errors

Table 2-6 shows the possible combinations for the receive signals.

Table 2-6: Possible Values for `phy_dv`, `phy_rx_er`, and `phy_rx_data[3:0]`

<code>phy_dv</code>	<code>phy_rx_er</code>	<code>phy_rx_data[3:0]</code>	Indication
0	0	0000 through 1111	Normal inter-frame
0	1	0000	Normal inter-frame
0	1	0001 through 1101	Reserved
0	1	1110	False carrier indication
0	1	1111	Reserved
1	0	0000 through 1111	Normal data reception
1	1	0000 through 1111	Data reception with errors

phy_crs

The PHY drives the Carrier Sense signal (**phy_crs**) active to indicate that either the transmit or receive is non-idle when operating in half-duplex mode. The signal **phy_crs** is deasserted when both the transmit and receive are idle. The PHY asserts **phy_crs** for the duration of a collision condition. The signal **phy_crs** is not synchronous to either the **phy_tx_clk** or the **phy_rx_clk**. The **phy_crs** signal is not used in full duplex mode. The **phy_crs** signal is used by both the AXI Ethernet Lite MAC transmit and receive circuitry and is double-synchronized to the processor clock as it enters the AXI Ethernet Lite MAC core.

phy_col

The PHY asserts the Collision detected signal (**phy_col**) to indicate the detection of a collision on the bus. The PHY asserts **phy_crs** while the collision condition persists. The PHY also drives **phy_col** asserted when operating at 10 Mb/s for signal_quality_error (SQE) testing.

The signal **phy_col** is not synchronous to either the **phy_tx_clk** or the **phy_rx_clk**. The **phy_col** signal is not used in full-duplex mode. The **phy_col** signal is used by both the AXI Ethernet Lite MAC core transmit and receive circuitry and is double-synchronized to the processor clock as it enters the AXI Ethernet Lite MAC. Figure 2-5 shows the behavior of **phy_col** during frame transmission with a collision.

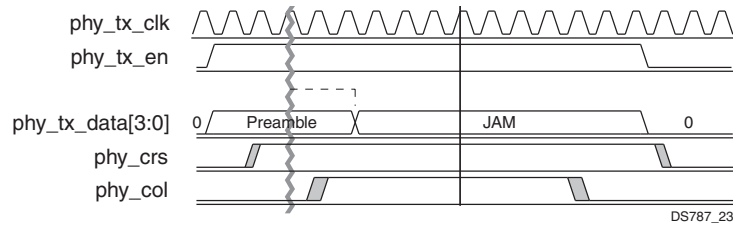

Figure 2-5: Transmission with Collision

Register Space

Table 2-7 shows all the AXI Ethernet Lite MAC core registers and their addresses. Tables 2-8 to 2-17 show the bit allocation and reset values of the registers.

Table 2-7: AXI Ethernet Lite Register Map

Address Offset	Register Name	Description
07E4h	MDIOADDR ⁽¹⁾	MDIO address register
07E8h	MDIOWR ⁽¹⁾	MDIO write data register
07ECh	MDIORD ⁽¹⁾	MDIO read data register
07F0h	MDIOCTRL ⁽¹⁾	MDIO control register
07F4h	TX Ping Length	Transmit length register for ping buffer
07F8h	GIE	Global interrupt register
07FCh	TX Ping Control	Transmit control register for ping buffer
0FF4h	TX Pong Length ⁽²⁾	Transmit length register for pong buffer
0FFCh	TX Pong Control ⁽²⁾	Transmit control register for pong buffer
17FCh	RX Ping Control	Receive control register for ping buffer
1FFCh	RX Pong Control ⁽³⁾	Receive control register for pong buffer

Notes:

1. These registers are included only if **Enable MII Management Module** is set in the Vivado IDE.
2. These registers are included only if **Enable Transmit Buffers** is set in the Vivado IDE.
3. These registers are included only if **Enable Receive Buffers** is set in the Vivado IDE.

Transmit Length Register

The Transmit Length register is a 32-bit read/write register (Figure 2-6). This register is used to store the length (in bytes) of the transmit data stored in dual port memory. The higher 8 bits of the length value should be stored in data bits 15 to 8, while the lower 8 bits should be stored in data bits 7 to 0. The bit definition of this register for the ping and pong buffer interface is shown in Table 2-8.

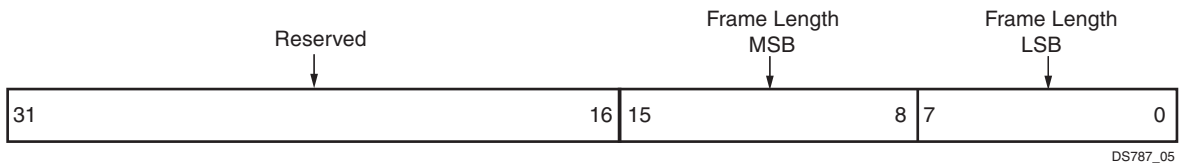

Figure 2-6: Transmit Length Register

Table 2-8: Transmit Length Register (0x07F4),(0x0FF4)

Bits	Name	Access	Reset value	Description
31:16	Reserved	N/A	N/A	Reserved
15:8	MSB	Read/Write	0	The higher 8 bits of the frame length
7:0	LSB	Read/Write	0	The lower 8 bits of the frame length

Global Interrupt Enable Register (GIE)

The Global Interrupt Enable register is a 32-bit read/write register (Figure 2-7). The Global Interrupt Enable Register provides the master enable/disable for the interrupt output (IP2Intc_Irpt signal) to the processor. The bit definition of this register is shown in Table 2-9.

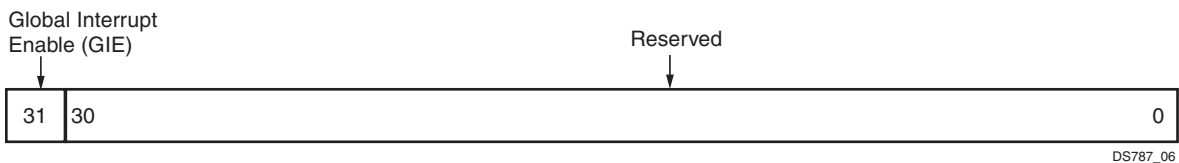

Figure 2-7: Global Interrupt Enable

Table 2-9: Global Interrupt Enable Register (0x07F8)

Bits	Name	Access	Reset value	Description
31	GIE	Read/Write	0	Global Interrupt Enable bit
30:0	Reserved	N/A	N/A	Reserved

Transmit Control Register (Ping)

The Transmit Control register for the ping buffer is a 32-bit read/write register (Figure 2-8). This register is used to enable the global interrupt, internal loopback and to initiate transmit transactions. The bit definition of this register is shown in Table 2-10.

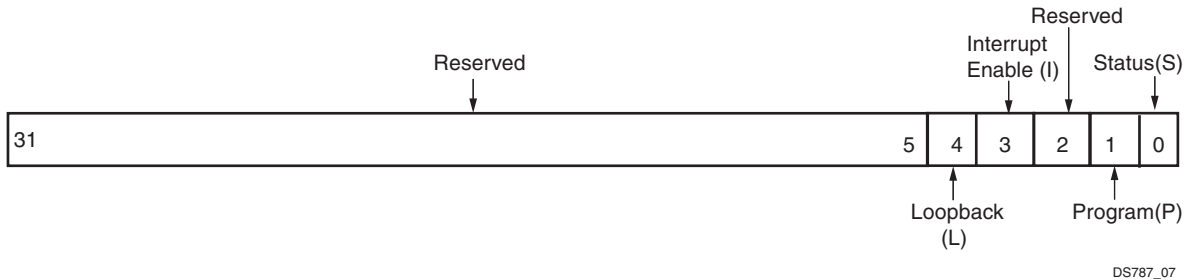

Figure 2-8: Transmit Control Register (Ping)

Table 2-10: Transmit Control Register (0x07FC)

Bits	Name	Access	Reset value	Description
31:5	Reserved	N/A	N/A	Reserved
4	Loopback ⁽¹⁾	Read/Write	0	Internal loopback enable bit 0 – No internal loopback 1 – Internal loopback enable
3	Interrupt Enable	Read/Write	0	Transmit Interrupt Enable bit 0 – Disable transmit interrupt 1 – Enable transmit interrupt
2	Reserved	N/A	N/A	Reserved
1	Program	Read/Write	0	AXI Ethernet Lite MAC address program bit. Setting this bit and status bit configures the new Ethernet MAC address for the core as described in Ethernet MAC Address in Chapter 3 .
0	Status	Read/Write	0	Transmit ping buffer status indicator 0 – Transmit ping buffer is ready to accept new frame 1 – Frame transfer is in progress. Setting this bit initiates transmit transaction. When transmit is complete, the AXI Ethernet Lite MAC core clears this bit.

Notes:

1. Internal Loopback is supported only in full duplex operation mode. Write to this bit is only valid when, Internal Loopback is enabled from the Vivado IDE options.

Transmit Control Register (Pong)

The Transmit Control register for the pong buffer is a 32-bit read/write register (Figure 2-9). This register is used for Ethernet MAC address programming and to initiate transmit transaction from the pong buffer. The bit definition of this register is shown in Table 2-11.

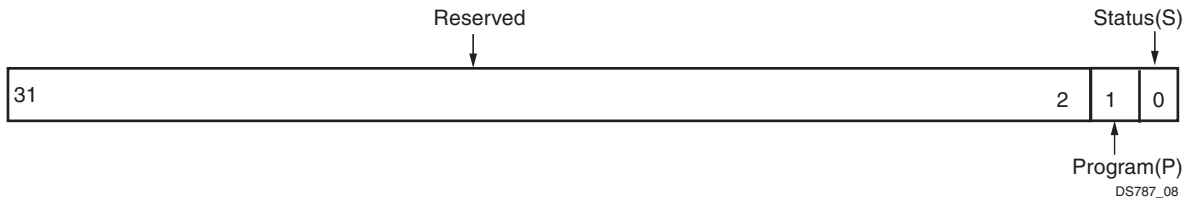

Figure 2-9: Transmit Control Register (Pong)

Table 2-11: Transmit Control Register (0x0FFC)

Bits	Name	Access	Reset value	Description
31:2	Reserved	N/A	N/A	Reserved
1	Program	Read/Write	0	AXI Ethernet Lite MAC address program bit. Setting this bit and status bit configures the new Ethernet MAC address for the core as described in Ethernet MAC Address in Chapter 3 .
0	Status	Read/Write	0	Transmit pong buffer status indicator 0 – Transmit pong buffer is ready to accept a new frame 1 – Frame transfer is in progress. Setting this bit initiates transmit transaction. When transmit is complete, the Ethernet Lite Ethernet MAC core clears this bit.

Receive Control Register (Ping)

The Receive Control register for the ping buffer is a 32-bit read/write register (Figure 2-10). This register indicates whether there is a new packet in the ping buffer. The bit definition of this register is shown in Table 2-12.

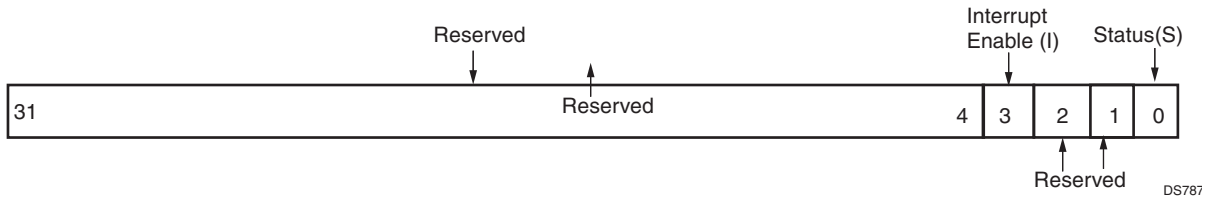

Figure 2-10: Receive Control Register (Ping)

Table 2-12: Receive Control Register (0x17FC)

Bits	Name	Access	Reset value	Description
31:4	Reserved	N/A	N/A	Reserved
3	Interrupt Enable	Read/Write	0	Receive Interrupt Enable bit 0 – Disable receive interrupt 1 – Enable receive interrupt
2:1	Reserved	N/A	N/A	Reserved
0	Status	Read/Write	0	Receive status indicator 0 – Receive ping buffer is empty. AXI Ethernet Lite MAC can accept new valid packet. 1 – Indicates presence of receive packet ready for software processing. When the software reads the packet from the receive ping buffer, the software must clear this bit.

Receive Control Register (Pong)

The Receive Control register for the pong buffer is a 32-bit read/write register (Figure 2-11). This register indicates whether there is a new packet in the pong buffer. The bit definition of this register is shown in Table 2-13.

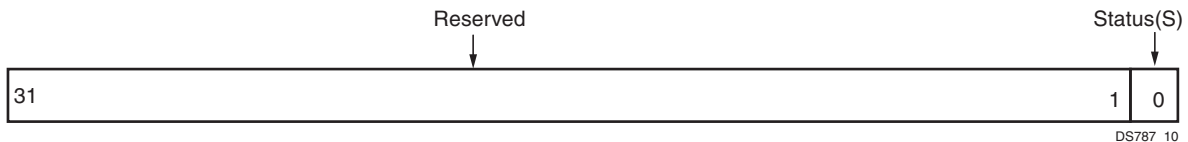

Figure 2-11: Receive Control Register (Pong)

Table 2-13: Receive Control Register (0x1FFC)

Bits	Name	Access	Reset value	Description
31:1	Reserved	N/A	N/A	Reserved
0	Status	Read/Write	0	Receive status indicator 0 – Receive pong buffer is empty. AXI Ethernet Lite MAC can accept new available valid packet. 1 – Indicates presence of receive packet ready for software processing. When the software reads the packet from the receive pong buffer, the software must clear this bit.

MDIO Address Register (MDIOADDR)

The MDIOADDR is a 32-bit read/write register (Figure 2-12). This register is used to configure the PHY device address, PHY register address and type of MDIO transaction. The bit definition of this register is shown in Table 2-14.

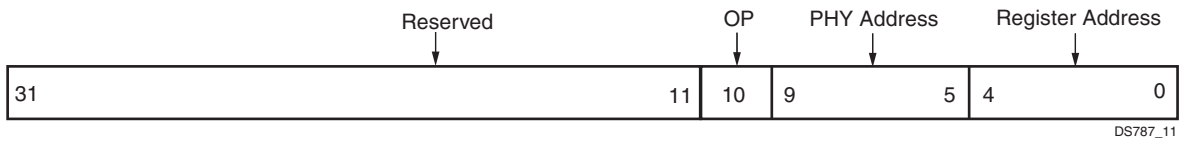

Figure 2-12: MDIO Address Register

Table 2-14: MDIO Address Register (0x07E4)

Bits	Name	Access	Reset Value	Description
31:11	Reserved	N/A	N/A	Reserved
10	OP	Read/Write	0	Operation Access Type 0 – Write Access 1 – Read Access
9:5	PHYADDR	Read/Write	0	PHY device address
4:0	REGADDR	Read/Write	0	PHY register address

MDIO Write Data Register (MDIOWR)

The MDIOWR is a 32-bit read/write register (Figure 2-13). This register contains 16-bit data to be written in to the PHY register. The bit definition of this register is shown in Table 2-15.

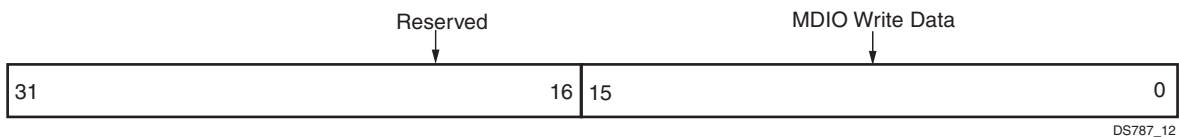

Figure 2-13: MDIO Write Data Register

Table 2-15: MDIO Write Data Register (0x07E8)

Bits	Name	Access	Reset Value	Description
31:16	Reserved	N/A	N/A	Reserved
15:0	Write Data	Read/Write	0	MDIO write data to be written to PHY register

MDIO Read Data Register (MDIORD)

The MDIORD is a 32-bit read/write register (Figure 2-14). This register contains 16-bit read data from the PHY register. The bit definition of this register is shown in Table 2-16.

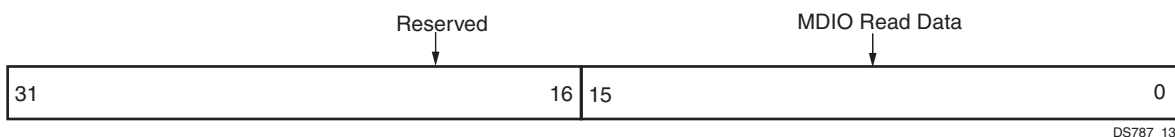

Figure 2-14: MDIO Read Data Register

Table 2-16: MDIO Read Data Register (0x07EC)

Bits	Name	Access	Reset Value	Description
31:16	Reserved	N/A	N/A	Reserved
15:0	Read Data	Read	0	MDIO read data from the PHY register

MDIO Control Register (MDIOCTRL)

The MDIOCTRL is a 32-bit read/write register (Figure 2-15). This register contains status and control information of the MDIO interface. The MDIO Enable (bit 3) of this register is used to enable the MDIO interface. The bit definition of this register is shown in Table 2-17.

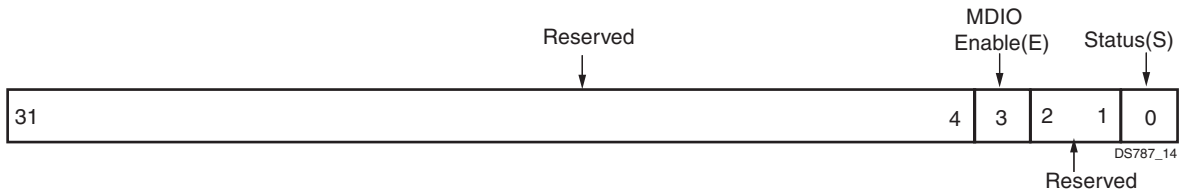

Figure 2-15: MDIO Control Register

Table 2-17: MDIO Control Register (0x07F0)

Bits	Name	Access	Reset Value	Description
31:4	Reserved	N/A	N/A	Reserved
3	MDIO Enable	Read/Write	0	MDIO enable bit 0 – Disable MDIO interface 1 – Enable MDIO interface
2:1	Reserved	N/A	N/A	Reserved
0	Status	Read/Write	0	MDIO status bit 0 – MDIO transfer is complete and core is ready to accept a new MDIO request 1 – MDIO transfer is in progress. Setting this bit initiates an MDIO transaction. When the MDIO transaction is complete, the AXI Ethernet Lite MAC core clears this bit.

Designing with the Core

This chapter includes guidelines and additional information to facilitate designing with the core.

Clocks

The AXI Ethernet Lite MAC design has three clock domains that are all asynchronous to each other. The clock domain diagram for the AXI Ethernet Lite MAC is shown in [Figure 3-1](#). These clock domains and any special requirements regarding them are discussed in the subsequent sections. Control signals crossing a clock domain are synchronized to the destination clock domain.

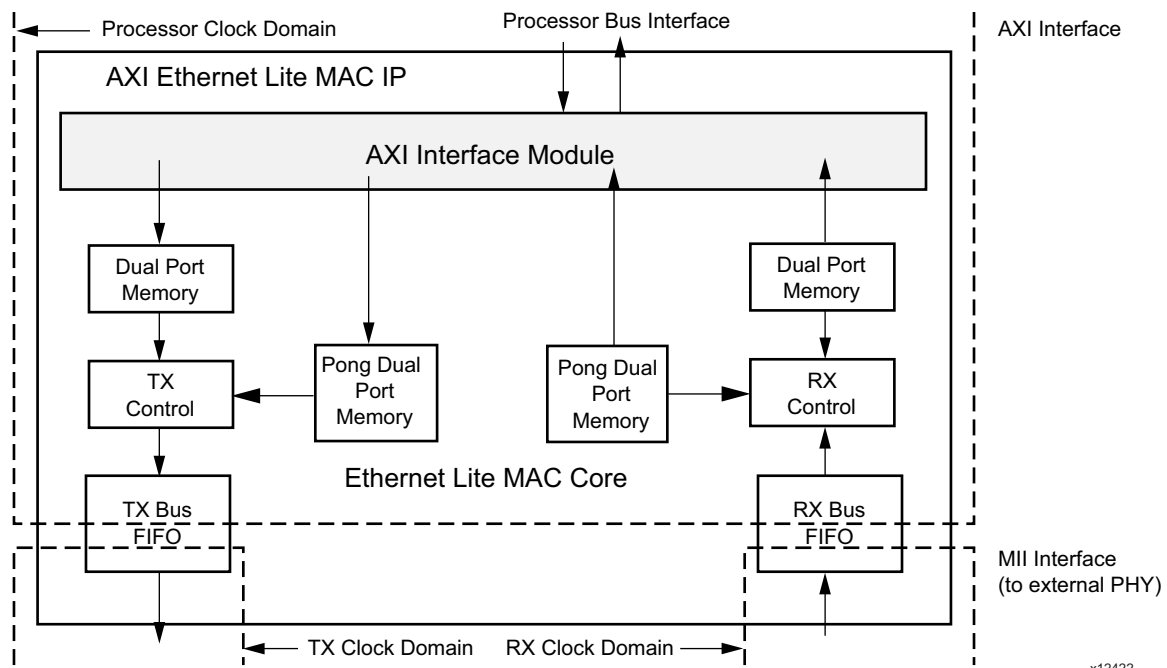

Figure 3-1: AXI Ethernet Lite MAC Clock Domain

Transmit Clock

The transmit clock [`phy_tx_clk`] is generated by the external PHY and must be used by the AXI Ethernet Lite MAC core to provide transmit data [`phy_tx_data [3:0]`] and to control signals [`phy_tx_en`] to the PHY.

The PHY provides one clock cycle for each nibble of data transferred resulting in a 2.5 MHz clock for 10BASE-T operation and 25 MHz for 100BASE-T operation at ± 100 ppm with a duty cycle of between 35% and 65%, inclusive. The PHY derives this clock from an external oscillator or crystal.

Receive Clock

The receive clock [`phy_rx_clk`] is also generated by the external PHY but is derived from the incoming Ethernet traffic. Similarly to the transmit clock, the PHY provides one clock cycle for each nibble of data transferred, resulting in a 2.5 MHz clock for 10BASE-T operation and 25 MHz for 100BASE-T operation with a duty cycle of between 35% and 65%, inclusive, while incoming data is valid [`phy_dv` is 1].

The minimum high and low times of the receive clock are at least 35% of the nominal period under all conditions. The receive clock is used by the AXI Ethernet Lite MAC core to sample the receive data [`phy_rx_data (3:0)`] and control signals [`phy_dv` and `phy_rx_er`] from the PHY.

AXI4 Clock (Processor Bus Clock)

The majority of the AXI Ethernet Lite MAC operation functions in the processor bus clock domain. This clock must be ≥ 100 MHz to transmit and receive Ethernet data at 100 Mb/s and ≥ 10 MHz to transmit and receive Ethernet data at 10 Mb/s.

Resets

The AXI Ethernet Lite core works on the `s_axi_aresetn`, which is active-Low. The reset assertion timing is dependent upon the slowest AXI Ethernet Lite clock. In general allow thirty clock cycles of the slowest AXI Ethernet Lite clock to elapse before accessing the core. Failure to do causes unpredictable behavior.

The `phy_rst_n` output signal is an active-Low reset that is tied directly to the AXI reset signal (`s_axi_aresetn`). This signal can be connected to the active-Low reset input of a PHY device.

Programming Sequence

This section contains the following subsections.

- [Transmit Interface](#)
- [Receive Interface](#)

Transmit Interface

The transmit data should be stored in the dual port memory starting at address **0x0**. Because of the word aligned addressing, the second four bytes are located at **0x4**. The 32-bit interface requires that all four bytes be written at once; there are no individual byte enables within one 32-bit word. The transmit data must include the destination address (6 bytes), the source address (6 bytes), the type/length field (2 bytes), and the data field (0 – 1,500 bytes). The preamble, start-of-frame, and CRC should not be included in the dual port memory. The destination, source, type/length, and data must be packed together in contiguous memory.

Dual port memory addresses **0x07F4** is used to store the length (in bytes) of the transmit data stored in dual port memory. The higher 8 bits of the length value should be stored in data bits 15 to 8, while the lower 8 bits should be stored in data bits 7 to 0.

Dual port memory address **0x07F8** is used to set the global interrupt enable (GIE) bit. Setting the GIE = 0 prevents the `IP2INTC_Irpt` from going active during an interrupt event. Setting GIE = 1 allows the `ip2intc_irpt` to go active when an interrupt event occurs.

The least two significant bits of dual port memory address **0x07FC** are control bits (Program or "P" and Status or "S"). The fourth bit (Bit[3] on the data bus) (Transmit Interrupt Enable or "I") is used to enable transmit complete interrupt events. This event is a pulse and occurs when the memory is ready to accept new data. The transmit complete interrupt occurs only if GIE and this bit are both set to 1.

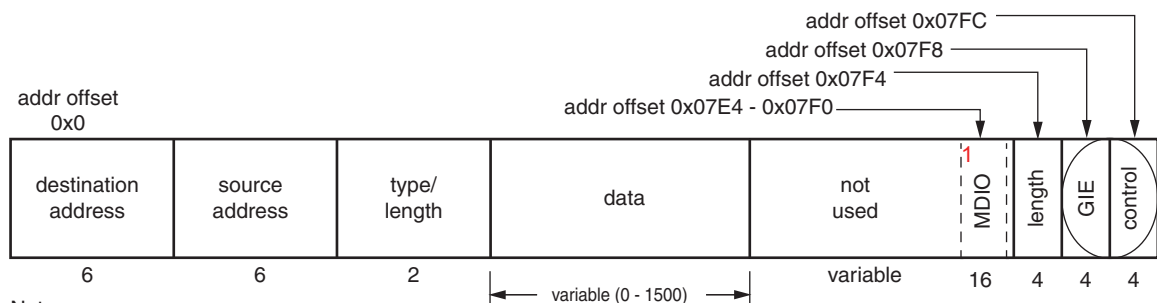

1. MDIO registers are included in the design if the parameter **Enable MII Management Module** is checked.

DS787_15

Figure 3-2: Transmit Dual Port Memory

Software Sequence for Transmit with Ping Buffer

The AXI Ethernet Lite MAC core requires that the length of the transmit data to be stored in address `0x07F4` before the software sets the status bit at offset `0x07FC`. The software sequence for initiating a transmit is:

- The software stores the transmit data in the dual port memory starting at address `0x0`
- The software writes the length data in the dual port memory at address `0x07F4`
- The software writes a 1 to the status bit at address `0x07FC` (Bit[0] on the data bus)
- The software monitors the status bit and waits until it is set to 0 by the AXI Ethernet Lite MAC core before initiating another transmit
- If the transmit interrupt and the global interrupt are both enabled, an interrupt occurs when the AXI Ethernet Lite MAC core clears the status bit
- The transmit interrupt, if enabled, also occurs with the completion of writing the Ethernet MAC address

Setting the status bit to a 1 initiates the AXI Ethernet Lite MAC core transmit to perform the following functions:

- Generates the preamble and start-of-frame fields
- Reads the length and the specified amount of data out of the dual port memory according to the length value, adding padding if required
- Detects any collision and performs any jamming, backs off and retries, if necessary
- Calculates the CRC and appends it to the end of the data
- Clears the status bit at the completion of the transmission
- Clearing the status bit causes a transmit complete interrupt, if enabled

Software Sequence for Transmit with Ping-Pong Buffer

If **Number of Transmit Buffers** is set to 1, two memory buffers exist for the transmit data. The original (ping transmit buffer) remains at the same memory address and controls the global interrupt enable. The second (pong buffer) is mapped at `0x0800` through `0x0FFC`. The length and status must be used in the pong buffer the same as in the ping buffer. The I bit and Global Interrupt Enable (GIE) bit are not used from the pong buffer (that is, the I bit and GIE bit of the ping buffer alone control the I bit and GIE bit settings for both buffers). The Ethernet MAC address can be set from the pong buffer. The transmitter always empties the ping buffer first after a reset. Then, if data is ready to be transmitted from the pong buffer, that transmission takes place. However, if the pong buffer is not ready to transmit data, the AXI Ethernet Lite MAC core begins to monitor both the ping and pong buffers and transmits the buffer that is ready first.

The software sequence for initiating a transmit with both a ping and pong buffer is:

- The software stores the transmit data in the dual port memory starting at address `0x0`.
- The software writes the length data in the dual port memory at address `0x07F4`.
- The software writes a 1 to the status bit at address `0x07FC` (Bit[0] on the data bus).
- The software can write to the pong buffer (`0x0800 – 0x0FFC`) at any time.
- The software monitors the status bit in the ping buffer and waits until it is set to 0, or waits for a transmit complete interrupt, before filling the ping buffer again.
- If the transmit interrupt and the global interrupt are both enabled, an interrupt occurs when the AXI Ethernet Lite MAC core clears the status bit.
- The transmit interrupt, if enabled, also occurs with the completion of writing the Ethernet MAC address.

Setting the status bit to a 1 initiates the AXI Ethernet Lite MAC core transmit which performs the following functions:

- Generates the preamble and start-of-frame fields
- Reads the length and the specified amount of data out of the dual port memory according to the length value, adding padding if required
- Detects any collision and performs any jamming, backs off, and retries if necessary
- Calculates the CRC and appends it to the end of the data
- Clears the status bit at the completion of the transmission
- Clearing the status bit causes a transmit complete interrupt if enabled
- The hardware then transmits the pong buffer if it is available, or begins monitoring both ping and pong buffers until data is available

Ethernet MAC Address

The 48-bit Ethernet MAC address defaults at reset to 00-00-5E-00-FA-CE. This value can be changed by performing an address program operation using the transmit dual port memory.

The software sequence for programming a new Ethernet MAC address is:

- The software loads the new Ethernet MAC address in the transmit dual port memory, starting at address `0x0`. The most significant four bytes are stored at address `0x0` and the least significant two bytes are stored at address `0x4`. The Ethernet MAC address can also be programmed from the pong buffer starting at `0x0800`.
- The software writes a 1 to both the program bit (Bit[1] on the data bus) and the status bit (Bit[0] on the data bus) at address `0x07FC`. The pong buffer address is `0x0FFC`.
- The software monitors the status and program bits and waits until they are set to 0 before performing any additional Ethernet operations.

A transmit complete interrupt, if enabled, occurs when the status and program bits are cleared.

Receive Interface

The entire receive frame data from destination address to the end of the CRC is stored in the receive dual port memory area which starts at address **0x1000**. The preamble and start-of-frame fields are not stored in dual port memory. Dual port memory address **0x17FC** (Bit[0] on the data bus) is used as a status to indicate the presence of a receive packet that is ready for processing by the software.

Dual port memory address **0x17FC** (Bit[3] on the data bus) is the Receive Interrupt enable. This event is a pulse and occurs when the memory has data available. The receive complete interrupt occurs only if this bit and GIE are both set to 1.

When the status bit is 0, the AXI Ethernet Lite MAC monitors the Ethernet for packets with a destination address that matches its Ethernet MAC address or the broadcast address. If a packet satisfies either of these conditions, the packet is received and stored in dual port memory starting at address **0x1000**. When the packet has been received, the AXI Ethernet Lite MAC core verifies the CRC. If the CRC value is correct, the status bit is set. If the CRC bit is incorrect, the status bit is not set and the AXI Ethernet Lite MAC core resumes monitoring the Ethernet bus.

Also, if the AXI Ethernet Lite MAC core receive Runt Frame (frame length less than the 60 Bytes) with a valid CRC, the core does not set the status bit and the interrupt is not generated. When the status bit is set, the AXI Ethernet Lite MAC does not perform any receive operations until the bit has been cleared to 0 by the software, indicating that all of the receive data has been retrieved from the dual port memory.

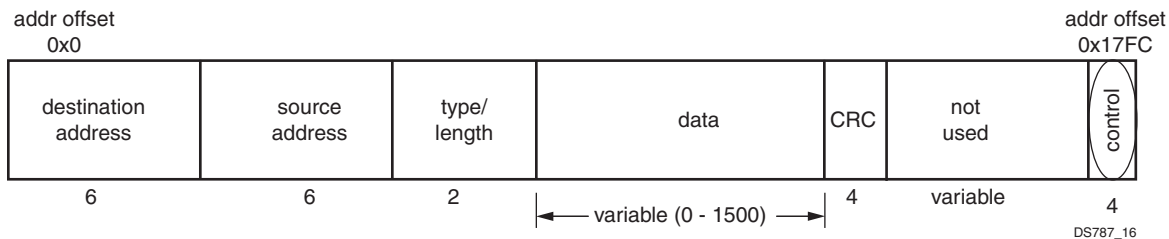

Figure 3-3: Receive Dual Port Memory

Software Sequence for Receive with Ping Buffer

The software sequence for processing a receive is:

1. The software monitors the receive status bit until it is set to 1 by the AXI Ethernet Lite MAC core and waits for a receive complete interrupt, if enabled.
2. When the status is set to 1, or a receive complete interrupt has occurred, the software reads the entire receive data out of the dual port memory.
3. The software writes a 0 to the receive status bit enabling the AXI Ethernet Lite MAC core to resume receive processing.

Software Sequence for Receive Ping-Pong

If **Number of Receive Buffers** is set to 1 then two memory buffers exist for the receive data. The original (ping receive buffer) remains at the same memory location. The second (pong receiver buffer) is mapped to **0x1800** through **0x1FFC**. Data is stored the same way in the pong buffer as it is in the ping buffer.

The software sequence for processing a receive packet(s) with **Number of Receive Buffers** = 1 is:

1. The software monitors the ping receive status bit until it is set to 1 by the AXI Ethernet Lite MAC, or waits for a receive complete interrupt, if enabled.
2. When the ping status is set to 1, or a receive complete interrupt has occurred, the software reads the entire receive data out of the ping dual port memory.
3. The AXI Ethernet Lite MAC receives the next packet and stores it in the pong receive buffer.
4. The software writes a 0 to the ping receive status bit, enabling the AXI Ethernet Lite MAC core to receive another packet in the ping receive buffer.
5. The software monitors the pong receive status bit until it is set to 1 by the AXI Ethernet Lite MAC core, or waits for a receive complete interrupt, if enabled.
6. When the pong status is set to 1, or a receive complete interrupt has occurred, the software reads the entire receive data out of the ping dual port memory.
7. The hardware always writes the first received packet, after a reset, to the ping buffer; the second received packet is written to the pong buffer and the third received packet is written to the ping buffer, and so forth.



IMPORTANT: *Not clearing the status bit of ping and pong buffer results in packet loss. For example, after correctly receiving two packet status bits of both ping and pong, buffers are set to 1 by the AXI Ethernet Lite MAC. If software only clears status bit of pong buffer, then the third packet would be lost (as this packet is intended to be received by ping buffer but its status bit is not cleared) and the IP would correctly receive the fourth packet.*

Management Data Input/Output (MDIO) Master Interface

The Management Data Input/Output Master Interface is included in the design if the parameter **Enable MII Management Module** is checked in the Vivado® Integrated Design Environment (IDE). Including this logic allows AXI Ethernet Lite MAC core to access PHY configuration registers. The MDIO Master Interface module is designed to incorporate the features described in IEEE 802.3 Media Independent Interface (MII) specification.

The MDIO module generates management data clock to the PHY (**phy_mdcc**) with a minimum period of 400 ns. The signal **phy_mdcc** is sourced to PHY as timing reference for transfer of information on the **phy_mdio** (Management Data Input/Output) data signal.

The **phy_mdio** signal is a bidirectional signal between the PHY and MDIO module. It is used to transfer control and status information between the PHY and the MDIO module. The control information is driven by the MDIO module synchronously with respect to **phy_mdcc** and is sampled synchronously by the PHY. The status information is driven by the PHY synchronously with respect to **phy_mdcc** and is sampled synchronously by the MDIO module. The signal **phy_mdio** is driven through a 3-state circuit that enables either the MDIO module or the PHY to drive the circuit.

The MDIO interface uses a standard method to access PHY management registers. The MDIO module supports up to 32 PHY devices. To access each PHY device, the PHY device address must be written into the MDIO Address (MDIOADDR) register followed by PHY register address (Figure 2-12). This module supports access to up to 32 PHY management registers. The write transaction data for the PHY must be written into MDIO Write Data (MDIOWR) register and the status data from the PHY register can be read from the MDIO Read Data (MDIORD) register. The MDIO Control (MDIOCTRL) register is used to initiate to management transaction on the MDIO lines.

The AXI Ethernet Lite MAC requires that the PHY device address and PHY register address be stored in the MDIO Address Register at address **0x07E4** before the software sets the status bit in the MDIO Control Register at offset **0x07F0**.

The software sequence for initiating a PHY register write transaction is:

1. The software reads the MDIOCTRL register to verify if the MDIO master is busy executing a previous request. If the status bit is 0, the MDIO master can accept a new request.
2. The software stores the PHY device address and PHY register address and writes 0 to Bit[10] in the MDIOADDR register at address **0x07E4**.
3. The software stores the PHY register write data in the MDIOWR register at address **0x07E8**.

4. The software writes 1 in the MDIO enable bit in the MDIOCTRL register at address **0x07F0**.
5. The software writes a 1 to the status bit at address **0x07F0** (Bit[0] on the data bus) to start the MDIO transaction.
6. After completing the MDIO write transaction, the AXI Ethernet Lite MAC core clears the status bit.
7. The software monitors the status bit and waits until it is set to 0 by the AXI Ethernet Lite MAC before initiating new transaction on the MDIO lines.

The software sequence for initiating a PHY register read transaction is:

1. The software reads the MDIOCTRL register to verify if the MDIO master is busy executing a previous request. If the status bit is 0, the MDIO master can accept a new request.
2. The software stores the PHY device address and PHY register address and writes 1 to bit 10 in the MDIOADDR register at address **0x07E4**.
3. The software writes 1 in the MDIO enable bit in the MDIOCTRL register at address **0x07F0**.
4. The software writes a 1 to the status bit at address **0x07F0** (bit 0 on the data bus) to start the MDIO transaction.
5. After completing the MDIO Read transaction, the AXI Ethernet Lite MAC core clears the status bit.

The software monitors the status bit and waits until it is set to 0 by the AXI Ethernet Lite MAC core before initiating a new transaction on the MDIO lines.

Ethernet Protocol

Ethernet data is encapsulated in frames (Figure 3-4). The fields and bits in the frame are transmitted from left to right (from the least significant bit to the most significant bit), unless specified otherwise.

Preamble

The preamble field is used for synchronization and must contain seven bytes with the pattern 10101010. If a collision is detected during the transmission of the preamble or start-of-frame delimiter fields, the transmission of both fields is completed.

For transmission, this field is always automatically inserted by the AXI Ethernet Lite MAC core and should never appear in the packet data provided to the AXI Ethernet Lite MAC core. For reception, this field is always stripped from the packet data. The AXI Ethernet Lite MAC design does not support the Ethernet 8-byte preamble frame type.

Start Frame Delimiter

The start frame delimiter field marks the start of the frame and must contain the pattern 10101011. If a collision is detected during the transmission of the preamble or start-of-frame delimiter fields, the transmission of both fields is completed.

The receive data valid signal from the PHY (`phy_dv`) can go active during the preamble but is active prior to the start frame delimiter field. For transmission, this field is always automatically inserted by the AXI Ethernet Lite MAC core and should never appear in the packet data provided to the AXI Ethernet Lite MAC core. For reception, this field is always stripped from the packet data.

Destination Address

The destination address field is 6 bytes in length. The least significant bit of the destination address is used to determine if the address is an individual/unicast (0) or group/multicast (1) address. Multicast addresses are used to group logically related stations.

The broadcast address (destination address field is all 1s) is a multicast address that addresses all stations on the LAN. The AXI Ethernet Lite MAC supports transmission and reception of unicast and broadcast packets. The AXI Ethernet Lite MAC core does not support multicast packets. This field is always provided in the packet data for transmissions and is always retained in the receive packet data.

Note: The AXI Ethernet Lite MAC design does not support 16-bit destination addresses as defined in the IEEE 802 standard.

Source Address

The source address field is 6 bytes in length. This field is always provided in the packet data for transmissions and is always retained in the receive packet data.

Note: The AXI Ethernet Lite MAC design does not support 16-bit source addresses as defined in the IEEE 802 standard.

Type/Length

The type/length field is 2 bytes in length. When used as a length field, the value in this field represents the number of bytes in the subsequent data field. This value does not include any bytes that might have been inserted in the padding field following the data field. The value of this field determines if it should be interpreted as a length as defined by the IEEE 802.3 standard or a type field as defined by the Ethernet protocol.

The maximum length of a data field is 1,500 bytes. Therefore, a value in this field that exceeds 1,500 (**0x05DC**) indicates that a frame type rather than a length value is provided in this field. The IEEE 802.3 standard uses the value 1536 (**0x0600**) or greater to signal a type field. The AXI Ethernet Lite MAC does not perform any processing of the type/length field. This field is transmitted with the least significant bit first but with the high order byte first. This field is always provided in the packet data for transmissions and is always retained in the receive packet data.

Data

The data field can vary from 0 to 1,500 bytes in length. This field is always provided in the packet data for transmissions and is always retained in the receive packet data.

Pad

The pad field can vary from 0 to 46 bytes in length. This field is used to ensure that the frame length is at least 64 bytes in length (the preamble and SFD fields are not considered part of the frame for this calculation) which is required for successful Carrier Sense Multiple Access with Collision Detection (CSMA/CD) operation. The values in this field are used in the frame check sequence calculation but are not included in the length field value if it is used. The length of this field and the data field combined must be at least 46 bytes. If the data field contains 0 bytes, the pad field is 46 bytes. If the data field is 46 bytes or more, the pad field has 0 bytes. For transmission, this field is inserted automatically by the AXI Ethernet Lite MAC if required to meet the minimum length requirement. If present in the receive packet, this field is always retained in the receive packet data.

FCS

The Frame Check Sequence (FCS) field is 4 bytes in length. The value of the FCS field is calculated over the source address, destination address, length/type, data, and pad fields using a 32-bit CRC defined in paragraph 3.2.8 of [Ref 3]:

$$G(x) = x^{32} + x^{26} + x^{23} + x^{22} + x^{16} + x^{12} + x^{11} + x^{10} + x^8 + x^7 + x^5 + x^4 + x^2 + x^1 + x^0$$

The CRC bits are placed in the FCS field with the x^{31} term in the left most bit of the first byte and the x^0 term is the right most bit of the last byte (that is, the bits of the CRC are transmitted in the order $x^{31}, x^{30}, \dots, x^1, x^0$).

The AXI Ethernet Lite MAC implementation of the CRC algorithm calculates the CRC value a nibble at a time to coincide with the data size exchanged with the external PHY interface for each transmit and receive clock period. For transmission, this field is always inserted automatically by the AXI Ethernet Lite MAC core and is always retained in the receive packet data.

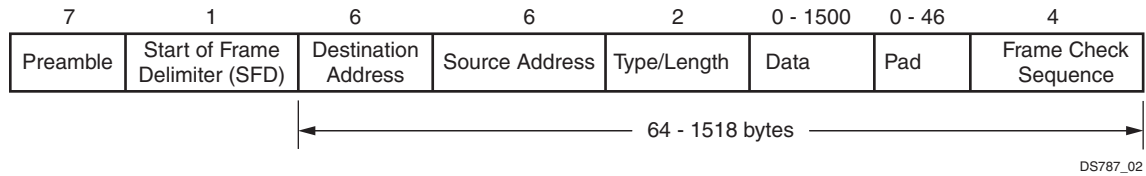

Figure 3-4: Ethernet Data Frame

Interframe Gap and Deferring

Note: Interframe Gap and interframe spacing are used interchangeably and are equivalent.

Frames are transmitted over the serial interface with an interframe gap which is specified by the IEEE Std. 802.3 to be 96 bit times (9.6 μ s for 10 MHz and 0.96 μ s for 100 MHz). The process for deferring is different for half-duplex and full-duplex systems and is as follows:

Half-Duplex

1. Even when it has nothing to transmit, the AXI Ethernet Lite MAC monitors the bus for traffic by watching the carrier sense signal (`phy_crs`) from the external PHY. Whenever the bus is busy (`phy_crs = 1`), the AXI Ethernet Lite MAC defers to the passing frame by delaying any pending transmission of its own.
2. After the last bit of the passing frame (when carrier sense signal changes from TRUE to FALSE), the AXI Ethernet Lite MAC starts the timing of the interframe gap.
3. The AXI Ethernet Lite MAC resets the interframe gap timer if the carrier sense becomes TRUE.

Full-Duplex

The AXI Ethernet Lite MAC does not use the carrier sense signal from the external PHY when in full duplex mode because the bus is not shared and only needs to monitor its own transmissions. After the last bit of an AXI Ethernet Lite MAC transmission, the AXI Ethernet Lite MAC starts the timing of the interframe gap.

CSMA/CD Method

A full-duplex Ethernet bus is, by definition, a point-to-point dedicated connection between two Ethernet devices capable of simultaneous transmit and receive with no possibility of collisions.

For a half-duplex Ethernet bus, the CSMA/CD media access method defines how two or more stations share a common bus. To transmit, a station waits (defers) for a quiet period on the bus (no other station is transmitting (`phy_crs = 0`)) and then starts transmission of its message after the interframe gap period.

If, after initiating a transmission, the message collides with the message of another station (`phy_col - 1`), then each transmitting station intentionally continues to transmit (jam) for an additional predefined period (32 bits for 10/100 Mb/s) to ensure propagation of the collision throughout the system. The station remains silent for a random amount of time (back off) before attempting to transmit again. A station can experience a collision during the beginning of its transmission (the collision window) before its transmission has had time to propagate to all stations on the bus. When the collision window has passed, a transmitting station has acquired the bus.

Subsequent collisions (late collisions) are avoided because all other (properly functioning) stations are assumed to have detected the transmission and are deferring to it. The time to acquire the bus is based on the round-trip propagation time of the bus (64 byte times for 10/100 Mb/s).

Transmit Flow

The flowchart in [Figure 3-5](#) shows the high level flow followed for packet transmission.

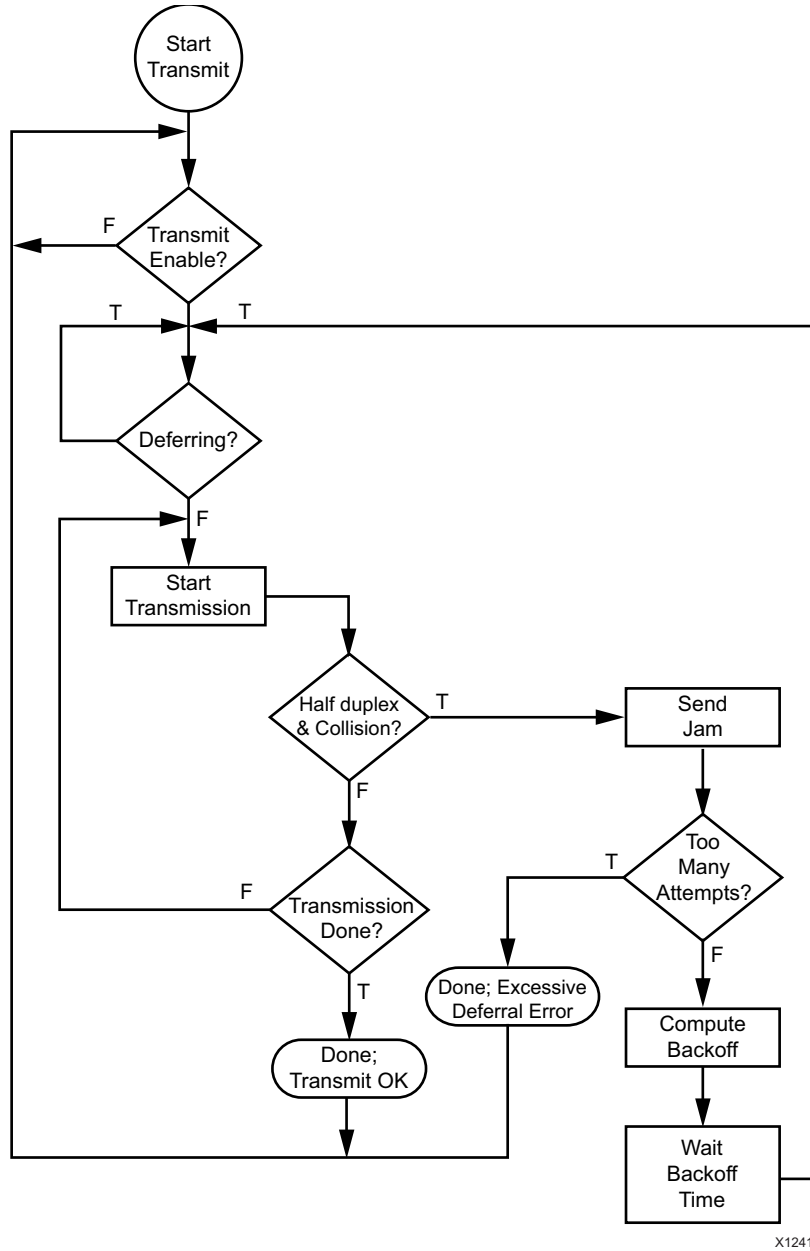

Figure 3-5: Transmit Flow

Receive Flow

The flowchart in Figure 3-6 shows the high level flow followed for packet reception.

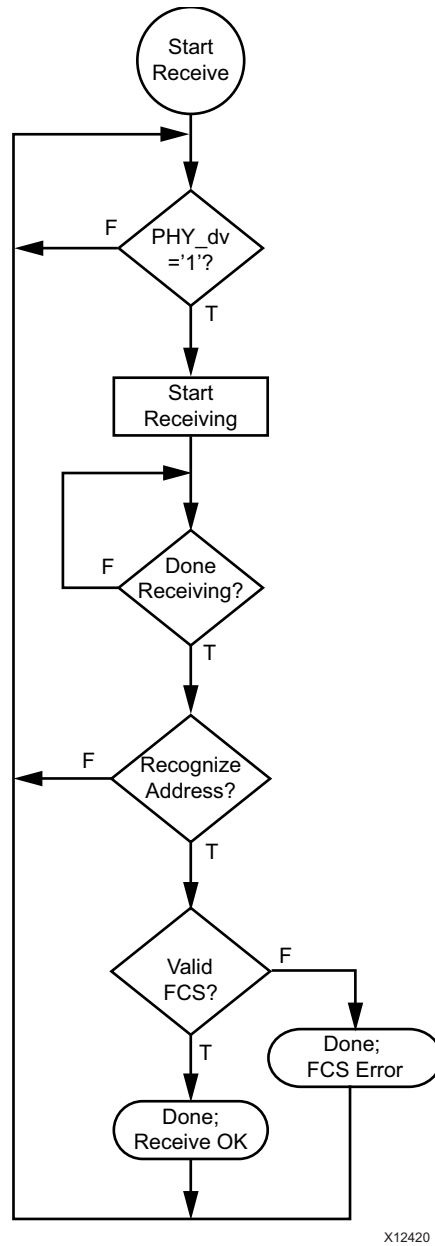

Figure 3-6: Receive Flow

Internal Loopback Mode

The AXI Ethernet Lite MAC core can be configured in internal loopback mode by setting the parameter **Enable Internal Loopback** is checked in the Vivado IDE and by setting bit 4 of the Transmit Control Register (Ping). In loopback mode, the logic uses BUFG for PHY clock switching. In this mode, the AXI Ethernet Lite MAC core routes back data on the TX lines to the RX lines. The loopback mode can be tested only in full duplex mode. In this mode, the core does not accept any data from the PHY and `phy_tx_clk` and `phy_tx_en` are used as `phy_rx_clk` and `phy_dv` internally (Figure 3-7).

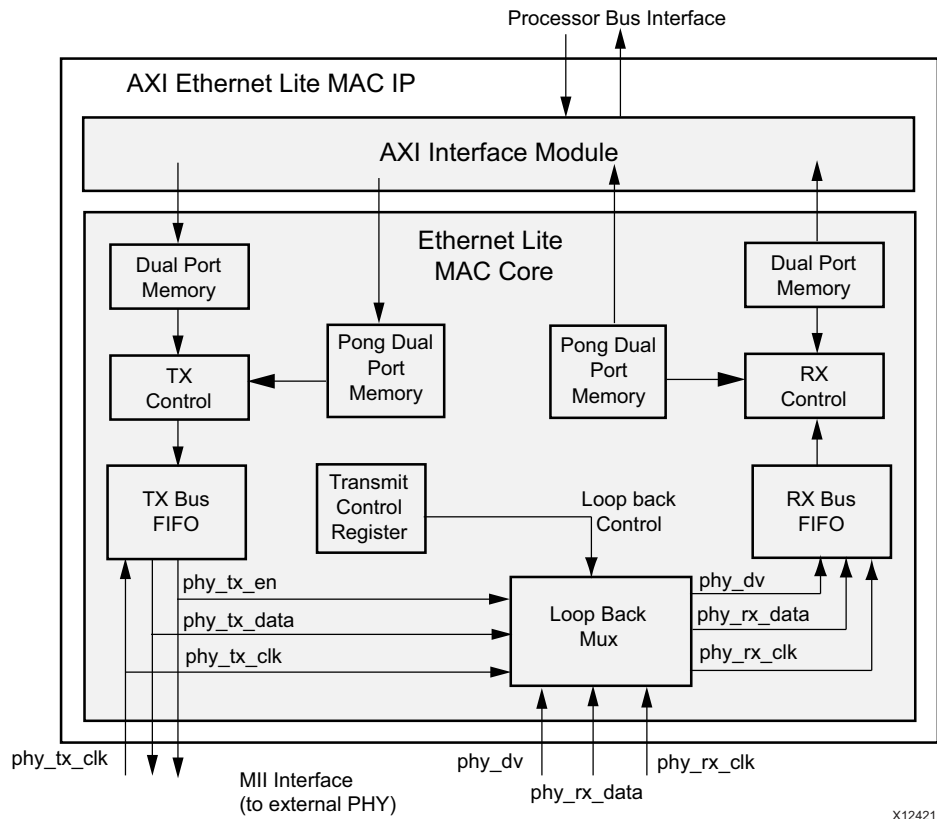

Figure 3-7: Internal Loopback Mode

Design Flow Steps

This chapter describes customizing and generating the core, constraining the core, and the simulation, synthesis and implementation steps that are specific to this IP core. More detailed information about the standard Vivado[®] design flows and the Vivado IP integrator can be found in the following Vivado Design Suite user guides:

- *Vivado Design Suite User Guide: Designing with IP* (UG896) [\[Ref 1\]](#)
- *Vivado Design Suite User Guide: Designing IP Subsystems using IP Integrator* (UG994) [\[Ref 4\]](#)
- *Vivado Design Suite User Guide: Getting Started* (UG910) [\[Ref 5\]](#)
- *Vivado Design Suite User Guide: Logic Simulation* (UG900) [\[Ref 6\]](#)

Customizing and Generating the Core

This section includes information about using Xilinx tools to customize and generate the core in the Vivado[®] Design Suite.

If you are customizing and generating the core in the IP integrator, see the *Vivado Design Suite User Guide: Designing IP Subsystems using IP Integrator* (UG994) [\[Ref 4\]](#) for detailed information. IP integrator might auto-compute certain configuration values when validating or generating the design. To check whether the values do change, see the description of the parameter in this chapter. To view the parameter value you can run the `validate_bd_design` command in the Tcl Console.

To access the AXI Ethernet Lite, perform the following:

1. Open a project by selecting **File > Open Project** or create a new project by selecting **File > New Project**.
2. Open **Vivado IP Catalog** and choose Embedded Processing/High Speed Peripheral.
3. Double-click AXI Ethernet Lite to display the AXI Ethernet Lite Vivado IDE.

For details, see the *Vivado Design Suite User Guide: Designing with IP* (UG896) [\[Ref 1\]](#) and the *Vivado Design Suite User Guide: Getting Started* (UG910) [\[Ref 5\]](#).

Note: Figure in this chapter is an illustration of the Vivado IDE. This layout might vary from the current version.

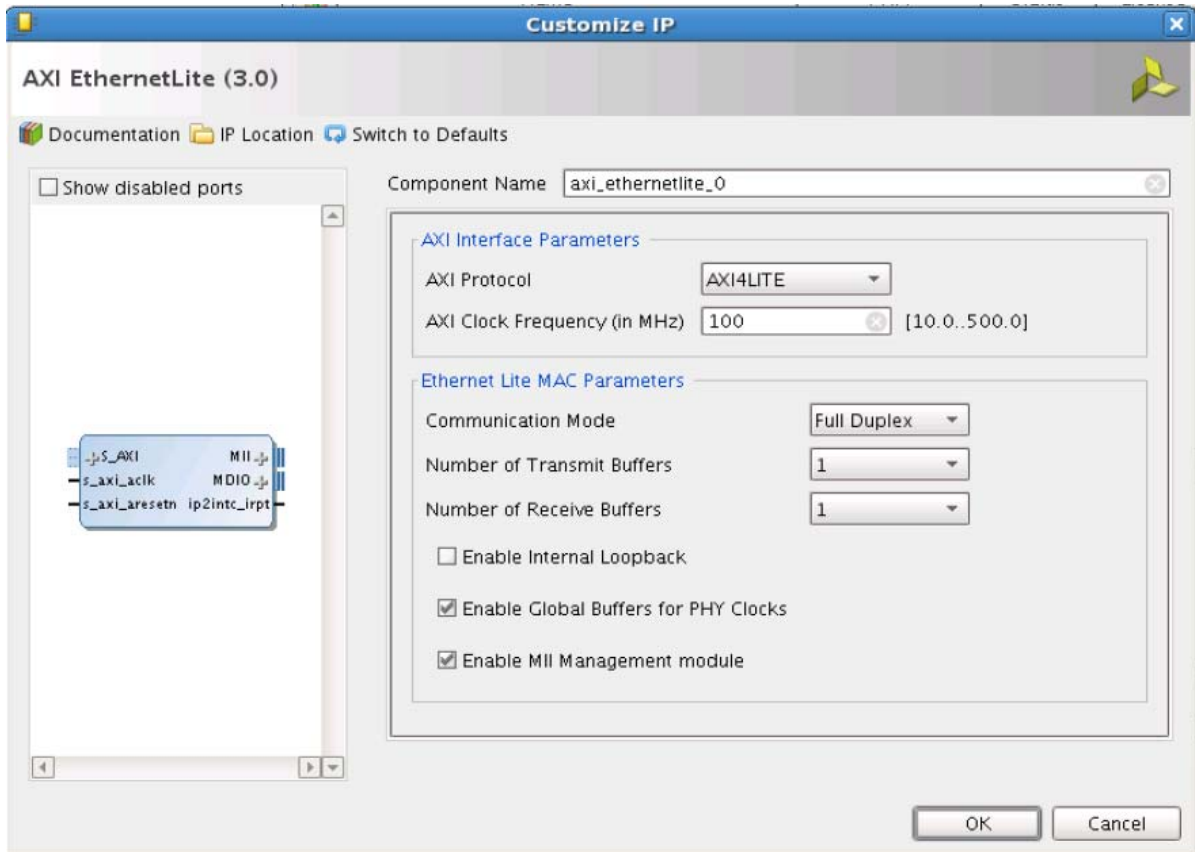

Figure 4-1: Vivado IDE

Field Descriptions

All the parameters except ID WIDTH are available in IP integrator. ID Width is auto-computed which means that you are not allowed to override

AXI Interface Parameters

- **AXI Protocol**
 - **AXI4** – Enables AXI4 interface
 - **AXI4LITE** – Enables AXI4-Lite interface
- **AXI Clock Frequency (in MHz)** – AXI Ethernet Lite core frequency. See [Table 2-1](#) for maximum supported frequency.

Ethernet Lite MAC Parameters

- **Communication Mode**
 - **Full Duplex** – Enables full duplex mode
 - **Half Duplex** – Enables half duplex mode
- **Number of Transmit Buffers**
 - **0** – Enables single TX buffer
 - **1** – Enables dual TX buffers
- **Number of Receive Buffers**
 - **0** – Enables single RX buffer
 - **1** – Enables dual RX buffers
- **Enable Internal Loopback** – Configures AXI Ethernet Lite in internal loopback mode when enabled
- **Enable Global Buffers for PHY Clocks**

Note: Internal loopback is supported only in full duplex mode.

 - **0** – Normal Input buffers for PHY Clocks
 - **1** – Global buffers for PHY Clocks
- **ID Width** – ID width of the AXI interface. Allowed values are 0 to 16.

Note: ID Width is auto-computed which means that you are not allowed to override it.
- **Enable MII Management Module** – Includes MDIO module that provides access to PHY registers when enabled

User Parameters

Table 4-1 shows the relationship between the GUI fields in the Vivado IDE and the User Parameters (which can be viewed in the Tcl Console).

Table 4-1: GUI Parameter to User Parameter Relationship

GUI Parameter/Value ⁽¹⁾	User Parameter/Value ⁽¹⁾	Default Value ⁽¹⁾
AXI Protocol	C_S_AXI_PROTOCOL	AXI4LITE
AXI Clock Frequency ⁽²⁾	AXI_ACLK_FREQ_MHZ	100
Communication Mode ⁽³⁾	C_DUPLEX	1
Number of Transmit Buffers	C_TX_PING_PONG	1
Number of Receive Buffers	C_RX_PING_PONG	1
Enable Internal Loopback ⁽⁴⁾	C_INCLUDE_INTERNAL_LOOPBACK	0
Enable Global Buffers for PHY Clocks	C_INCLUDE_GLOBAL_BUFFERS	1

Table 4-1: GUI Parameter to User Parameter Relationship (Cont'd)

GUI Parameter/Value ⁽¹⁾	User Parameter/Value ⁽¹⁾	Default Value ⁽¹⁾
Enable MII Management Module	C_INCLUDE_MDIO	1
ID Width ⁽⁵⁾	C_S_AXI_ID_WIDTH	0

Notes:

- Parameter values are listed in the table where the GUI parameter value differs from the user parameter value. Such values are shown in this table as indented below the associated parameter.
- Clock frequency should be minimum four times of TX/RX clocks.
- Value "0" for Half Duplex and Value "1" for Full Duplex.
- Not applicable when Communication Mode is "0"(Half Duplex), and value should be "0."
- Applicable only when AXI Protocol is AXI4 (Full).

Output Generation

For details, see the *Vivado Design Suite User Guide: Designing with IP* (UG896) [Ref 1].

Constraining the Core

Design constraints as applicable are generated along with the other core deliverables in the Vivado Design Suite.

Required Constraints

This section is not applicable for this IP core.

Device, Package, and Speed Grade Selections

This section is not applicable for this IP core.

Clock Frequencies

This section is not applicable for this IP core.

Clock Management

This section is not applicable for this IP core.

Clock Placement

This section is not applicable for this IP core.

Banking

This section is not applicable for this IP core.

Transceiver Placement

This section is not applicable for this IP core.

I/O Standard and Placement

This section is not applicable for this IP core.

Simulation

This section contains information about simulating IP in the Vivado Design Suite. For comprehensive information about Vivado simulation components, as well as information about using supported third-party tools, see the *Vivado Design Suite User Guide: Logic Simulation* (UG900) [Ref 6].

Synthesis and Implementation

This section contains information about synthesis and implementation in the Vivado Design Suite. For details about synthesis and implementation, see the *Vivado Design Suite User Guide: Designing with IP* (UG896) [Ref 1].

Example Design

This chapter contains information about the example design provided in the Xilinx® Vivado® Design Suite.

Clicking **Open IP Example Design** in Vivado IDE (Sources Window on generated IP) or entering the `open_example_project` command (`get_ips <component_name>`) in the Tcl console invokes a separate example design project. In this new project `<component_name>_exdes` is the top module for synthesis, and `<component_name>_exdes_tb` is the top module for simulation. The implementation or simulation of the example design can be run from the example design.

Directory and File Contents

top directory

`<project_name>/<project_name>.srcs/sources_1/ip/`

VHDL Example design, Test bench, and coefficient (COE) files are the files that drive ATG to generate required AXI transactions.

The AXI Ethernetlite core directories and their associated files are defined in the following sections.

`<project_name>/<project_name>.srcs/sources_1/ip/`

The `<project directory>` contains all the Vivado design tool project files.

Table 5-1: `<project_name>/<project_name>.srcs/sources_1/ip/`

Name	Description
Synth/<component name>.v vhd	Synthesis wrapper generated by the Vivado design tools
Sim/<component name>.v vhd	Simulation wrapper generated by the Vivado design tools
<component name>.xci	Vivado tools project-specific option file; can be used as an input to the Vivado design tools.
<component name>.vho veo	VHDL or Verilog instantiation template

Table 5-1: `project_name>/<project_name>.srcs/sources_1/ip/` (Cont'd)

Name	Description
<code><component name>_ooc.xdc</code>	Out of Context constraints for IP
COE Files	These files are intended for the use with the example design. Right-click on the generated IP and select Open Example Design in the Vivado design tools to create the example design project

`<project_name>/<project_name>.srcs/sources_1/ip/<component name>`

The `<component name>` directory contains the HDL files that implement the core.

example design

The example design directory contains the example design files provided with the core.

Table 5-2: Example Design Directory

Name	Description
<code><component name>_exdes.vhd</code>	Example design top file for synthesis
<code><component name>_exdes_tb.vhd</code>	Example design top file for simulation
Exdes.xdc	Constrains for Example design

Example Design

The following sections describe the top-level example design for the AXI Ethernetlite core.

The complete example design works as a mini-system to show the AXI Ethernetlite core functionality by demonstrating the transmit and receive of the Ethernet packet.

Clock Generator

The AXI Ethernetlite example design makes use of the clocking wizard to supply clocks and resets to all other blocks in the design.

The clocking wizard is configured to provide two clocks.

- The first output with the frequency value with the option given in Vivado IDE; this is supplied as the primary clock to all blocks in the example design.
- The second output with the frequency 25 MHz which is the input for `phy_tx_clk` and `phy_rx_clk` for the AXI Ethernetlite IP core. The locked signal from the wizard is appropriately used as a reset.

AXI Traffic Generator (ATG)

The example design makes use of one or two AXI Traffic Generators based upon the AXI protocol selected in Vivado IDE.

- The ATG is used in the example design to write the raw data of the packet to the AXI Ethernetlite IP core and also to read/write the control/status registers of the core. The ATG determines the test pass/fail condition based upon the status read from core.
- One ATG is used in system test mode to control the transaction sequence in all configurations.
- The other ATG is used in AXI4 mode and is only instantiated when the AXI protocol selected is AXI4 for the AXI Ethernetlite core.

The ATG takes four COE files as input and provides Done and Status pins as outputs which determine the result of the tests.

Working Example Designs

AXI4-Lite Protocol without Internal Loopback

When the AXI4-Lite protocol is selected without Internal Loopback:

- The ATG in system test mode with two AXI channels enabled is used to write a Destination Address, Source Address, and test data into the 2k Memory present in core.
- The example design programs the registers in the AXI Ethernetlite core to indicate the number of bytes in a packet and to state that data is ready for packet transmission.
- The AXI Ethernetlite IP core generates the Ethernet packet and transmits it through the MII interface.
- Another instance of the AXI Ethernetlite IP core that is used in the example design receive the Ethernet packet.
- A CRC check that is performed by default in the IP assures the correct reception of the packet and updates the status register to indicate the same.
- The second channel of the ATG is connected to the partner AXI Ethernetlite IP core which reads the status register and gives a test pass/fail condition through the ATG Status and Done pins.

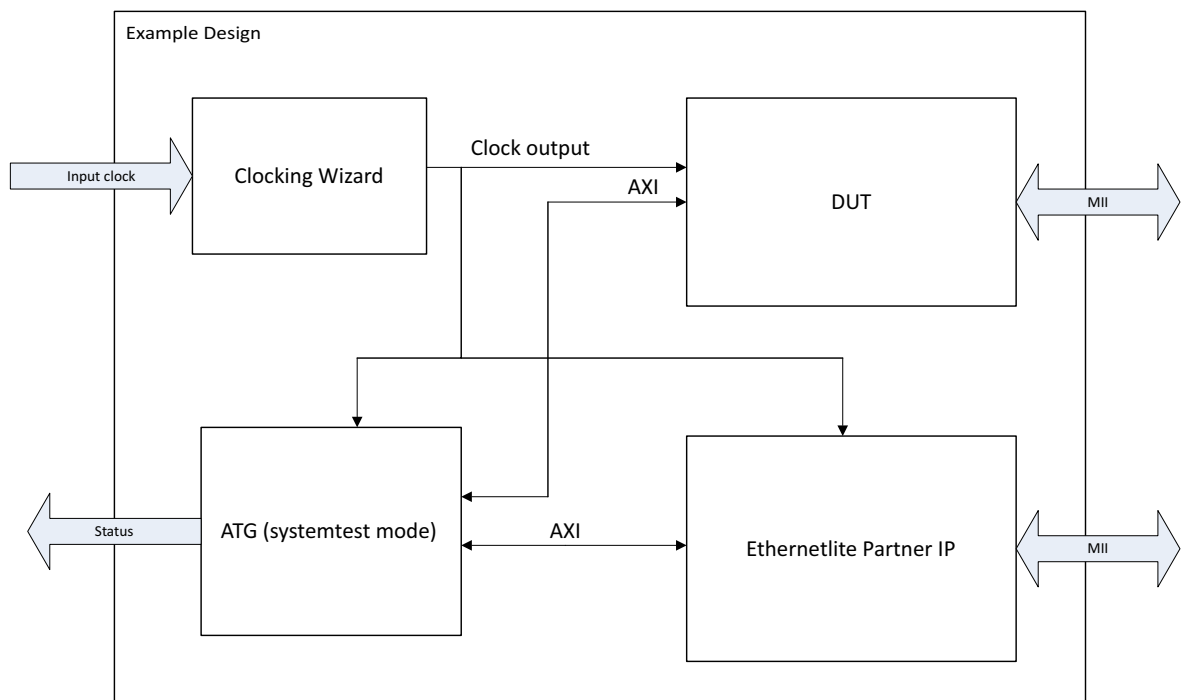

Figure 5-1: AXI4-Lite Example Design without Internal Loopback

AXI4 Protocol without Internal Loopback

When the AXI4 protocol is selected without Internal Loopback:

- Two ATGs are used: one in AXI4 mode is connected to the AXI Ethernetlite IP core and the other ATG in system test mode is used to configure the ATG Full mode.
- The ATG in system test mode configures another ATG to generate a burst transaction to transfer data into the AXI Ethernetlite IP core TX buffer. The content to be transferred in the AXI burst transaction is also loaded into ATF FULL using the system test mode.
- The ATG then updates the register in the AXI Ethernetlite core to start transmission of Ethernet packets.
- Another instance of the AXI Ethernetlite core that is used in the example design receives the Ethernet packet and updates the status registers based upon the CRC check performed.
- Another instance of ATG FULL connected to the partner IP reads the status and passes it to the ATG in system test mode which determines the test pass/fail condition.

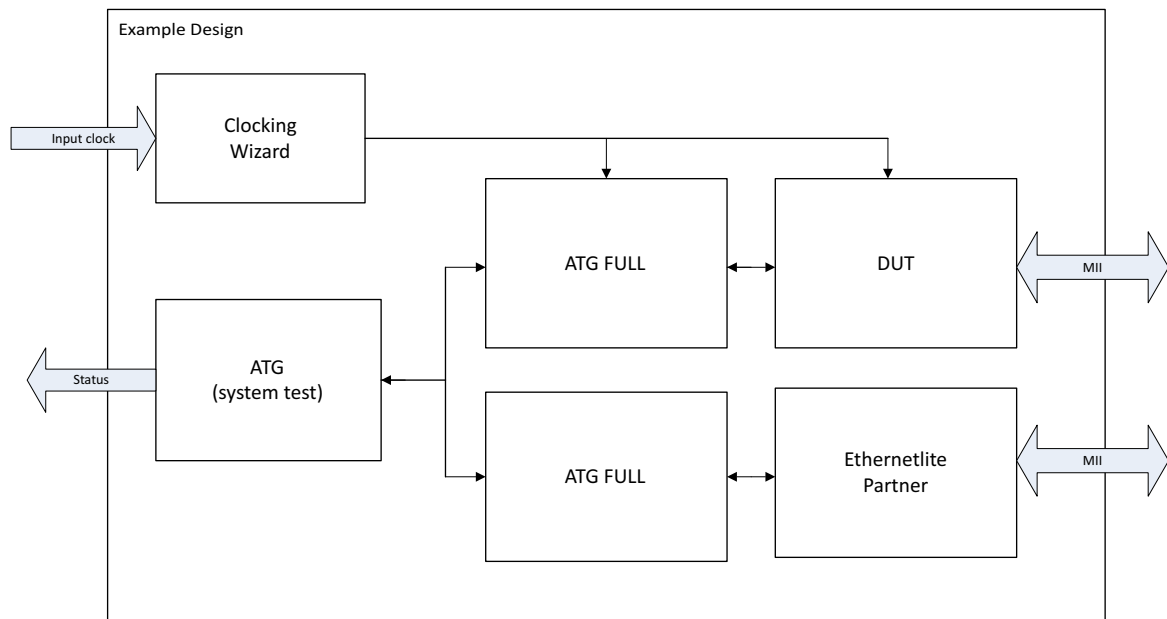

Figure 5-2: AXI4 Example Design without Internal Loopback

AXI4-Lite or AXI4 Protocol with Loopback

When Internal Loopback option is selected with Loopback:

- When the internal loopback option is enabled in either AXI4-Lite or AXI4 operating mode, the example design does not generate the partner IP because the single instance of the AXI Ethernetlite core performs transmit and receive operations.
- The ATG configures the IP memory with raw data and starts the packet transmission by updating the TX registers. The packet transmitted is looped back internally to the receiver circuitry. The MII interface extends to the test bench and is open at that hierarchy.
- The receiver takes in the packet and updates the status registers based upon the CRC check results.
- The ATG reads the receiver status registers to determine the test pass/fail condition.

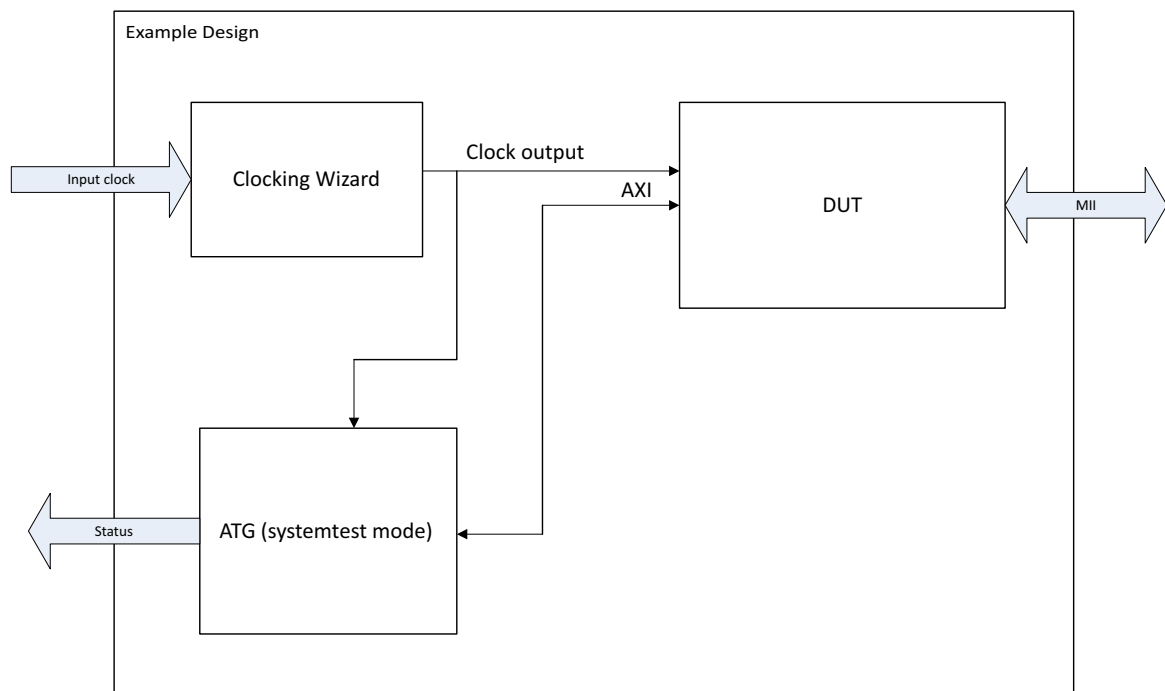

Figure 5-3: AXI4-Lite Example Design with Internal Loopback

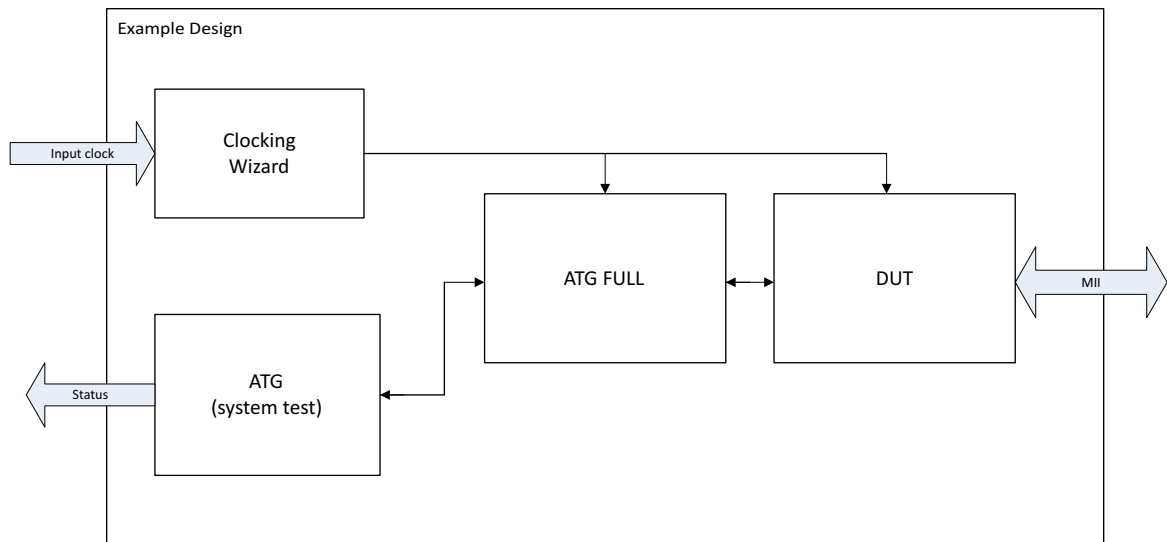

Figure 5-4: AXI4 Example Design with Internal Loopback

Test Bench

The following file describes the demonstration test bench for the AXI Ethernetlite core.

```
<project_name>/<project_name>.srcs/sources_1/ip/<component_name>/
<component_name>example_design/<component_name>_exdes.vhd
```

The demonstration test bench is a simple VHDL program to exercise the example design and the core.

The demonstration test bench performs the following tasks:

- Instantiates the example design top
- Connects the MII interfaces of DUT and AXI Ethernetlite partner IP core in non-loopback cases
- Generates clock and reset inputs for the clocking wizard
- Takes Done and Status pins from the ATG and determines the simulation status

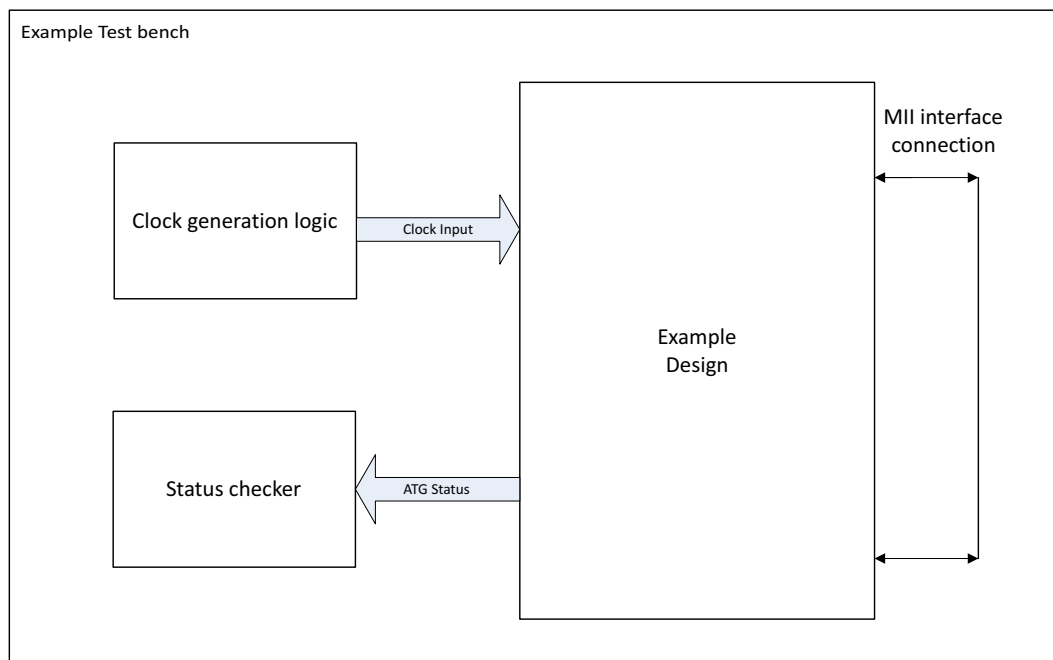

Figure 6-1: Test Bench

Simulating the Example Design

Using the AXI Ethernetlite example design (delivered as part of the AXI Ethernetlite), you can quickly simulate and observe the behavior of the AXI Ethernetlite.

Setting Up the Simulation

The Xilinx® simulation libraries must be mapped into the simulator. If the libraries are not set for your environment, see the *Vivado Design Suite User Guide: Logic Simulation (UG900)* [Ref 6] for assistance compiling Xilinx simulation models and setting up the simulator environment. To switch simulators, click **Simulation Settings** in the Flow Navigator (left pane). In the **Simulation** options list, change **Target Simulator**.

Simulation Results

The simulation script compiles the AXI Ethernetlite example design and supporting simulation files. It then runs the simulation and checks to ensure that it completed successfully.

If the test passes, then the following message is displayed:

```
Test Completed Successfully
```

If the test fails or does not complete, then the following message is displayed:

```
Test Hanged
```

This message is displayed when the example design simulation fails.

Upgrading

This appendix contains information about migrating a design from the ISE® Design Suite to the Vivado® Design Suite, and for upgrading to a more recent version of the IP core. For customers upgrading in the Vivado Design Suite, important details (where applicable) about any port changes and other impact to user logic are included.

Migrating to the Vivado Design Suite

This section is not applicable.

Upgrading in the Vivado Design Suite

This section is not applicable.

Debugging

This appendix includes details about resources available on the Xilinx[®] Support website and debugging tools.

Finding Help on Xilinx.com

To help in the design and debug process when using the AXI Ethernet Lite MAC core, the [Xilinx Support web page](#) contains key resources such as product documentation, release notes, answer records, information about known issues, and links for obtaining further product support.

Documentation

This product guide is the main document associated with the AXI Ethernet Lite MAC core. This guide, along with documentation related to all products that aid in the design process, can be found on the [Xilinx Support web page](#) or by using the Xilinx Documentation Navigator.

Download the Xilinx Documentation Navigator from the [Downloads page](#). For more information about this tool and the features available, open the online help after installation.

Solution Center

The Solution Center specific to the AXI Ethernet Lite MAC core is [Xilinx Ethernet IP Solution Center](#).

Answer Records

Answer Records include information about commonly encountered problems, helpful information on how to resolve these problems, and any known issues with a Xilinx product. Answer Records are created and maintained daily ensuring that users have access to the most accurate information available.

Answer Records for this core can be located by using the Search Support box on the main [Xilinx support web page](#). To maximize your search results, use proper keywords such as

- Product name
- Tool message(s)
- Summary of the issue encountered

A filter search is available after results are returned to further target the results.

Master Answer Record for the AXI Ethernet Lite MAC core

AR: [54389](#)

Technical Support

Xilinx provides technical support in the [Xilinx Support web page](#) for this LogiCORE™ IP product when used as described in the product documentation. Xilinx cannot guarantee timing, functionality, or support if you do any of the following:

- Implement the solution in devices that are not defined in the documentation.
- Customize the solution beyond that allowed in the product documentation.
- Change any section of the design labeled DO NOT MODIFY.

To contact Xilinx Technical Support, navigate to the [Xilinx Support web page](#).

Vivado Design Suite Debug Feature

The Vivado® Design Suite debug feature inserts logic analyzer and virtual I/O cores directly into your design. The debug feature also allows you to set trigger conditions to capture application and integrated block port signals in hardware. Captured signals can then be analyzed. This feature in the Vivado IDE is used for logic debugging and validation of a design running in Xilinx devices.

The Vivado logic analyzer is used with the logic debug IP cores, including:

- ILA 2.0 (and later versions)
- VIO 2.0 (and later versions)

See the *Vivado Design Suite User Guide: Programming and Debugging* (UG908) [\[Ref 7\]](#).

Hardware Debug

Hardware issues can range from link bring-up to problems seen after hours of testing. This section provides debug steps for common issues. The Vivado lab tools are a valuable resource to use in hardware debug. The signal names mentioned in the following individual sections can be probed using the Vivado lab tools for debugging the specific problems.

Ensure that all the timing constraints for the core were properly incorporated from the example design and that all constraints were met during implementation.

- Does it work in post-place and route timing simulation? If problems are seen in hardware but not in timing simulation, this could indicate a PCB issue. Ensure that all clock sources are active and clean.
- If using MMCMs in the design, ensure that all MMCMs have obtained lock by monitoring the `locked` port.
- If your outputs go to 0, check your licensing.

Additional Resources and Legal Notices

Xilinx Resources

For support resources such as Answers, Documentation, Downloads, and Forums, see [Xilinx Support](#).

Documentation Navigator and Design Hubs

Xilinx[®] Documentation Navigator provides access to Xilinx documents, videos, and support resources, which you can filter and search to find information. To open the Xilinx Documentation Navigator (DocNav):

- From the Vivado[®] IDE, select **Help > Documentation and Tutorials**.
- On Windows, select **Start > All Programs > Xilinx Design Tools > DocNav**.
- At the Linux command prompt, enter `docnav`.

Xilinx Design Hubs provide links to documentation organized by design tasks and other topics, which you can use to learn key concepts and address frequently asked questions. To access the Design Hubs:

- In the Xilinx Documentation Navigator, click the **Design Hubs View** tab.
- On the Xilinx website, see the [Design Hubs](#) page.

Note: For more information on Documentation Navigator, see the [Documentation Navigator](#) page on the Xilinx website.

References

These documents provide supplemental material useful with this product guide:

1. *Vivado® Design Suite User Guide: Designing with IP* ([UG896](#))
2. *Vivado AXI Reference Guide* ([UG1037](#))
3. IEEE Std. 802.3 Media Independent Interface Specification
4. *Vivado Design Suite User Guide: Designing IP Subsystems using IP Integrator* ([UG994](#))
5. *Vivado Design Suite User Guide: Getting Started* ([UG910](#))
6. *Vivado Design Suite User Guide: Logic Simulation* ([UG900](#))
7. *Vivado Design Suite User Guide: Programming and Debugging* ([UG908](#))
8. *Arm® AMBA® AXI4-Stream Protocol Specification* ([ARM IHI 0051A](#))
9. 7 series [documentation](#)
10. *AXI4 AMBA AXI Protocol Version: 2.0 Specification* ([ARM IHI 0022D](#))
11. *LogiCORE™ IP AXI Interconnect Product Guide* ([PG059](#))

Revision History

The following table shows the revision history for this document.

Date	Version	Revision
11/10/2021	3.0	Added support for Versal® ACAP
07/08/2020	3.0	Editorial updates only. No technical content updates.
05/22/2019	3.0	Editorial updates only. No technical content updates.
12/05/2018	3.0	Added a note on the cover page.
11/18/2015	3.0	Added support for UltraScale+ families.
10/01/2014	3.0	<ul style="list-style-type: none"> • Document updated only for revision change. • Updated Note #3 in Table 2-5: I/O Signal Descriptions. • Added Important Note in Software Sequence for Receive Ping-Pong section. • Added User Parameter table in Design Flow Steps chapter.
04/02/2014	3.0	<ul style="list-style-type: none"> • Added example design addition. • Changed MTBF.
12/18/2013	2.0	<ul style="list-style-type: none"> • Added UltraScale™ architecture support. • Changed all signal and port names to lowercase.
03/20/2013	2.0	Initial version of this product guide. This product guide replaces ds787.

Please Read: Important Legal Notices

The information disclosed to you hereunder (the "Materials") is provided solely for the selection and use of Xilinx products. To the maximum extent permitted by applicable law: (1) Materials are made available "AS IS" and with all faults, Xilinx hereby DISCLAIMS ALL WARRANTIES AND CONDITIONS, EXPRESS, IMPLIED, OR STATUTORY, INCLUDING BUT NOT LIMITED TO WARRANTIES OF MERCHANTABILITY, NON-INFRINGEMENT, OR FITNESS FOR ANY PARTICULAR PURPOSE; and (2) Xilinx shall not be liable (whether in contract or tort, including negligence, or under any other theory of liability) for any loss or damage of any kind or nature related to, arising under, or in connection with, the Materials (including your use of the Materials), including for any direct, indirect, special, incidental, or consequential loss or damage (including loss of data, profits, goodwill, or any type of loss or damage suffered as a result of any action brought by a third party) even if such damage or loss was reasonably foreseeable or Xilinx had been advised of the possibility of the same. Xilinx assumes no obligation to correct any errors contained in the Materials or to notify you of updates to the Materials or to product specifications. You may not reproduce, modify, distribute, or publicly display the Materials without prior written consent. Certain products are subject to the terms and conditions of Xilinx's limited warranty, please refer to Xilinx's Terms of Sale which can be viewed at <https://www.xilinx.com/legal.htm#tos>; IP cores may be subject to warranty and support terms contained in a license issued to you by Xilinx. Xilinx products are not designed or intended to be fail-safe or for use in any application requiring fail-safe performance; you assume sole risk and liability for use of Xilinx products in such critical applications, please refer to Xilinx's Terms of Sale which can be viewed at <https://www.xilinx.com/legal.htm#tos>.

AUTOMOTIVE APPLICATIONS DISCLAIMER

AUTOMOTIVE PRODUCTS (IDENTIFIED AS "XA" IN THE PART NUMBER) ARE NOT WARRANTED FOR USE IN THE DEPLOYMENT OF AIRBAGS OR FOR USE IN APPLICATIONS THAT AFFECT CONTROL OF A VEHICLE ("SAFETY APPLICATION") UNLESS THERE IS A SAFETY CONCEPT OR REDUNDANCY FEATURE CONSISTENT WITH THE ISO 26262 AUTOMOTIVE SAFETY STANDARD ("SAFETY DESIGN"). CUSTOMER SHALL, PRIOR TO USING OR DISTRIBUTING ANY SYSTEMS THAT INCORPORATE PRODUCTS, THOROUGHLY TEST SUCH SYSTEMS FOR SAFETY PURPOSES. USE OF PRODUCTS IN A SAFETY APPLICATION WITHOUT A SAFETY DESIGN IS FULLY AT THE RISK OF CUSTOMER, SUBJECT ONLY TO APPLICABLE LAWS AND REGULATIONS GOVERNING LIMITATIONS ON PRODUCT LIABILITY.

© Copyright 2020-2021 Xilinx, Inc. Xilinx, the Xilinx logo, Artix, ISE, Kintex, Spartan, Virtex, Vivado, Zynq, and other designated brands included herein are trademarks of Xilinx in the United States and other countries. AMBA, AMBA Designer, Arm, ARM1176JZ-S, CoreSight, Cortex, PrimeCell, Mali, and MPCore are trademarks of Arm Limited in the EU and other countries. All other trademarks are the property of their respective owners.