

# USXGMII Ethernet Subsystem v1.1

## *Product Guide*

**Vivado Design Suite**

PG251 June 26, 2020



# Table of Contents

## Chapter 1: Overview

Feature Summary . . . . .	5
Licensing and Ordering . . . . .	5

## Chapter 2: Product Specification

Standards . . . . .	10
Performance . . . . .	11
Resource Utilization . . . . .	12
Port Descriptions . . . . .	12
Register Space . . . . .	35

## Chapter 3: Designing with the Subsystem

General Design Guidelines . . . . .	79
Clocking and Resets . . . . .	81
Support for IEEE Standard 1588v2 . . . . .	82
Pause Processing . . . . .	87

## Chapter 4: Design Flow Steps

Customizing and Generating the Core . . . . .	92
Customizing and Generating the Core . . . . .	92
Constraining the Core . . . . .	101
Simulation . . . . .	102
Synthesis and Implementation . . . . .	103

## Chapter 5: Example Design

Overview . . . . .	104
Example Design Hierarchy (GT in Example Design) . . . . .	107
User Interface . . . . .	110
Shared Logic Implementation . . . . .	111
AXI4-Lite Interface Implementation . . . . .	114

## Chapter 6: Test Bench

### Appendix A: Verification, Compliance, and Interoperability

Simulation .....	120
Hardware Testing .....	120

### Appendix B: Upgrading

### Appendix C: Debugging

Finding Help on Xilinx.com .....	122
Debug Tools .....	123

### Appendix D: Additional Resources and Legal Notices

Xilinx Resources .....	124
Documentation Navigator and Design Hubs .....	124
References .....	125
Revision History .....	125
Please Read: Important Legal Notices .....	126

## Introduction

The Universal Serial 10GE Media Independent Interface (USXGMII) IP core implements an Ethernet Media Access Controller (MAC) with a mechanism to carry a single port of 10M, 100M, 1G, 2.5G, 5G or 10GE over an IEEE 802.3 Clause 49 BASE-R physical coding sublayer/physical layer (PCS/PHY). The USXGMII IP core is delivered as encrypted register transfer level (RTL) through the Vivado® Design Suite targeted for Xilinx® FPGAs.

## Features

- Designed to meet the USXGMII specification EDCS-1467841 revision 1.4
- Supports 10M, 100M, 1G, 2.5G, 5G, or 10GE data rates over a 10.3125 Gb/s link
- Both media access control (MAC) and PCS/PMA functions are included
- Code replication/removal of lower rates onto the 10GE link
- Rate adaption onto user clock domain
- Low data path latency
- 32-bit AXI4-Stream interface for datapath
- Optional AXI4-Lite register interface
- Support for 802.3x and priority-based pause operation
- Detailed statistics gathering
- Support for custom preambles
- Supports deficit idle count (DIC)

LogiCORE™ IP Facts Table	
<b>Core Specifics</b>	
Supported Device Family <sup>(1)</sup>	Virtex® UltraScale™, Kintex® UltraScale Virtex UltraScale+™, Kintex UltraScale+ Zynq UltraScale+ MPSoC
Supported User Interfaces	AXI4-Stream 32-bit Optional AXI4-Lite
Resources	<a href="#">Performance and Resource Utilization web page</a>
<b>Provided with Core</b>	
Design Files	Encrypted RTL
Example Design	Verilog
Test Bench	Verilog
Constraints File	Xilinx Design Constraints (XDC)
Simulation Model	Verilog
Supported S/W Driver	Not Applicable
<b>Tested Design Flows</b>	
Design Entry	Not Applicable
Simulation	For supported simulators, see the <a href="#">Xilinx Design Tools: Release Notes Guide</a> .
Synthesis	Not Applicable for Early Access
<b>Support</b>	
Release Notes and Known Issues	Master Answer Record: <a href="#">69886</a>
Provided by Xilinx at the <a href="#">Xilinx Support web page</a>	

**Notes:**

1. For GTX 7 series support, contact your [local Xilinx Sales Representative](#).
2. Xilinx recommends that you join the NBASE-T Alliance to gain access to the USXGMII specification. For more information on membership, visit the [NBASE-T Alliance website](#).

## Overview

The USXGMII core provides an architecture to convey a single port of Ethernet over a 10GE BASE-R link in a way that maximizes existing standards and thus reduces risk. The port can operate at an effective data rate of: 10M, 100M, 1GE, 2.5GE, 5GE or 10GE. The IP core is implemented with a low-latency 32-bit datapath.

Typical applications are to connect to an electrical Copper PHY (10GBASE-T) application-specific standard products (ASSPs).

This product guide contains an overview of the USXGMII IP core as well as example application, and licensing.

---

## Feature Summary

- Complete Ethernet MAC and PCS functions
- 32-bit serialize/deserializer (SerDes) interface using Xilinx<sup>®</sup> UltraScale<sup>™</sup> and UltraScale+<sup>™</sup> GT transceiver operating with Asynchronous Gearbox enabled
- Pause Processing including IEEE std. 802.3 Annex 31D (Priority based Flow Control)
- Custom preamble
- Clause 37 Auto Negotiation for USXGMII
- Configurable speed from 10 Mb/s to 10 Gb/s to connect to 10G base-T PHY

---

## Licensing and Ordering

The Xilinx<sup>®</sup> USXGMII IP cores are provided under the [Xilinx Core License Agreement](#), which must be executed for each design project. Contact your [local Xilinx sales representative](#) for more information on core pricing and availability.

For more information, please refer to the [USXGMII product web page](#).

Information about additional Xilinx<sup>®</sup> LogiCORE<sup>™</sup> IP modules is available on the [Xilinx Intellectual Property](#) page.

# Product Specification

Figure 2-1 shows the block diagram of the USXGMII IP, not including the GT transceiver.

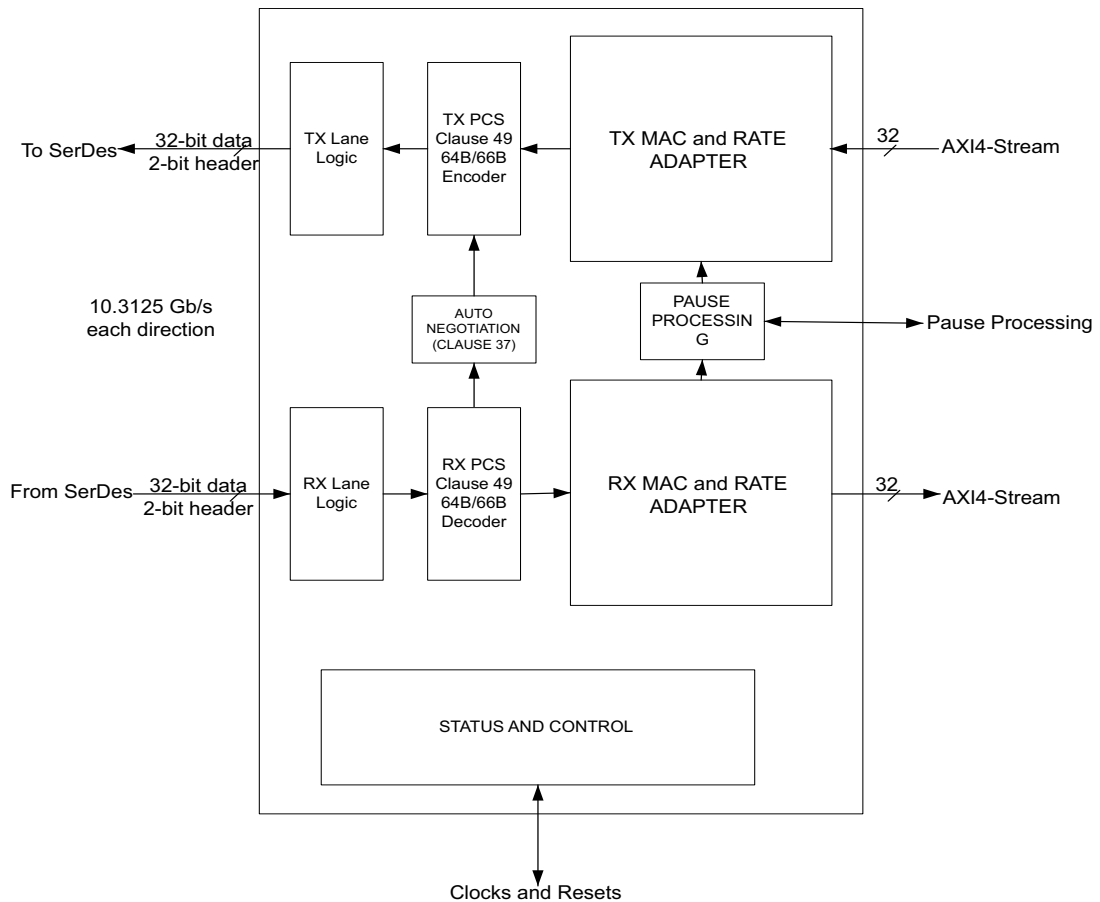

X22523-032019

Figure 2-1: Block Diagram

The USXGMII core uses two data signals in each direction to convey frame data and link rate information between a single or multi-port PHY and the Ethernet MAC(s). The data signals operate at 10.3125 Gb/s (USXGMII/XFI), using clock data recovery (CDR) technology to recover the clock at the MAC and PHY serial interfaces. Due to the high speed of operation, each of these signal pairs are realized as differential pairs thus optimizing signal integrity while minimizing system noise.

The USXGMII core leverages the 64B/66B PCS defined in IEEE 802.3 Clause 49. Data replication is used to encapsulate lower Ethernet rates (10M, 100M, 1G, etc) into BASE-R 66b words for translation into a USXGMII stream via the Clause 49 PCS.

The PCS is unchanged with additional functionality being added via the "ordered set" mechanism defined by the IEEE Group.

## TX Data Path

The 32-bit AXI4-Stream interface supports user-defined out-of-band preamble values, allowing USXGMII messages to be passed on packet preamble bytes.

On TX, every 32-bit word is replicated a number of times according to the rate selected by the auto-negotiation with the link partner, or by direct programming of the `ctl_usxgmii_rate[2:0]` port without auto-negotiation, when `ctl_umii_an_bypass = 1` (see [Port Descriptions](#) for encoding). Code word replication is used to pad out the less than 10GE rates, and Start and Terminate words are modified according to the USXGMII specification for seamless decoding.

## RX Datapath

On RX, replicated 32-bit words are discarded before the remaining unique packet data is passed on. The received preamble bytes are extracted from received packets and passed out alongside packet start of packets (SOPs).

As with the TX data path, when `ctl_umii_an_bypass = 1`, the USXGMII RX rate is determined by `ctl_usxgmii_rate[2:0]` (see [Port Descriptions](#) for encoding).

## USXGMII at Lower Speeds

Figure 2-2 and Figure 2-3 illustrate the start and termination of a packet transfer at 5 Gb/s.

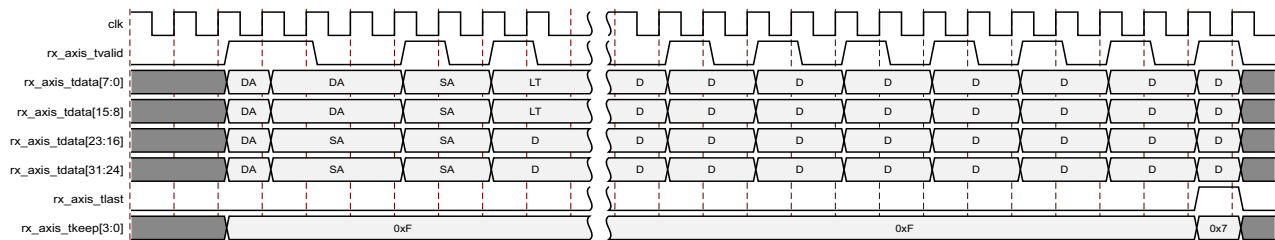

Figure 2-2: RX – Start of a Packet at 5 Gb/s

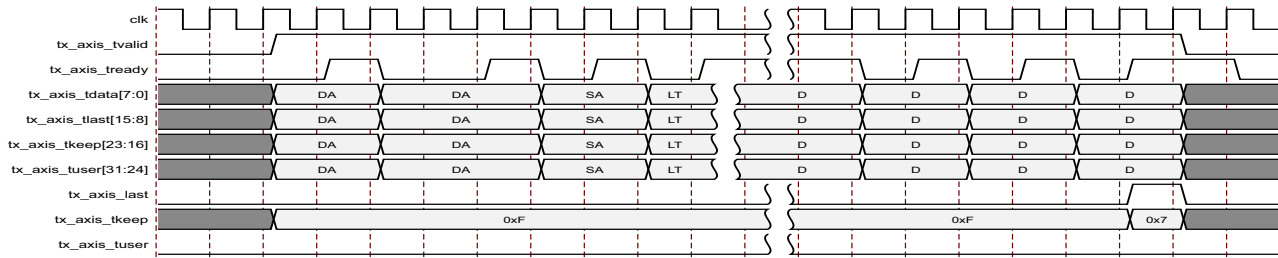

Figure 2-3: TX – Start of a Packet at 5 Gb/s

Each word of the preamble and payload is replicated 2/4/10/100/1000 times for 5G/2.5G/1G/100M/10M respectively.

## Auto-Negotiation

In the USXGMII core, the auto-negotiation is based on clause 37 of IEEE 802.3. The operation conforms to the description provided by EDCS-1467841 NBASE-T Universal SXGMII: Copper PHY ERS.

The USXGMII core creates three new types of ordered sets, besides the existing local fault and the remote fault. The `UsxgmiiChannellInfo` carries the auto-negotiation information. The control register `ctl_umii_an_mr_adv_ability` maps to `UsxgmiiChannellInfo`. The other two are `UmiiLocalFault` and `UmiiRemoteFault`. This ordered set is used to transfer the 16-bit `UsxgmiiChannellInfo` word(s) between the link partners. The bit meanings are laid out in EDCS-1467841. Amidst this data is the desired rate, that can be specified using bits 11:9 of `ctl_umii_an_mr_adv_ability`.

During auto-negotiation, each link partner continuously broadcasts the `UsxgmiiChannellInfo` word(s) to the respective link partners, and each link partner examines the received channel information message, and compares that message to what was being broadcast.

Then, following the clause 37 protocol, the auto-negotiation circuit will idle the lanes for the link-time-out value, and then the circuit will set the negotiated rate and enable mission-mode.

Currently, the core provides an 'autoneg\_bypass', similar in behavior to that of clause 73. When this is set, the autoneg function is disabled, and operation is preset to mission mode at the data rate that is set by the `ctl_usxgmii_rate` input.

Currently, the auto-negotiation resolves the rate to the lowest requested rate. However, there is an ambiguity in EDCS-1467841 that does not clearly specify how rates are to be resolved.



## Clause 37 Auto-Negotiation Operation

Signal names are

- `ctl_umii_an_mr_an_enable`
- `ctl_umii_an_mr_restart_an`
- `ctl_umii_an_mr_main_reset`
- `ctl_umii_an_bypass`

The `ctl_umii_an_mr_main_reset` is not the circuit reset input. It is the `mr_main_reset` as defined in clause 37.

When `ctl_umii_an_mr_main_reset` is asserted, the auto-negotiation (AN) will hold the state `AN_ENABLE`. In this state, if `ctl_umii_an_mr_an_enable` is set, the AN will configure the PCS for a 10G rate, and it will continuously send a zero `usx_config` word, but it will not do anything else until `ctl_umii_an_mr_main_reset` is cleared. If `ctl_umii_an_mr_an_enable` is not set, the AN will set the PCS to continuously send IDLES. The rate will be whatever was previously set. If there were no previous negotiations, the rate set will be to 10G. The AN will hold in state `AN_ENABLE` until the `ctl_umii_an_mr_main_reset` signal is removed.

When `ctl_umii_an_mr_main_reset` is removed, then, if `ctl_umii_an_mr_an_enable` is set, the AN will proceed to state `AN_RESTART`, and it will begin to negotiate the link, as per clause 37. If `ctl_umii_an_mr_an_enable` is not set, the AN will go to state `AN_DISABLE_LINK_OK`. In this state, the PCS is configured in mission mode, (that is, ready for traffic), at whatever rate was previously negotiated, and the AN circuit holds there.

If the `ctl_umii_an_bypass` signal is set, it automatically clears the internal `mr_an_enable` signal into the AN circuit, regardless of the setting of the `ctl_umii_an_mr_an_enable` input. It also automatically sets the PCS rate to whatever the `ctl_usxgmii_rate` input is set to, and it sets the PCS to mission-mode. The `ctl_umii_an_bypass` signal will also override the above described behavior of the `ctl_umii_an_mr_main_reset`. That is, the PCS will be configured into mission mode as described regardless of how `ctl_umii_an_mr_main_reset` and `ctl_umii_an_mr_an_enable` are set.

If the `ctl_umii_an_bypass` signal is not set, and the `ctl_umii_an_mr_main_reset` is also not set, and if the `ctl_umii_an_mr_an_enable` is set, and then if `ctl_umii_an_mr_restart_an` is asserted, the AN will enter state `AN_RESTART`, where it will proceed to negotiate the link, as per clause 37. In order to signal another restart, the `ctl_umii_an_mr_restart_an` has to be cycled. That is, it has to be cleared, and then set again. The restart is triggered on the positive transition of the `ctl_umii_an_mr_restart_an` signal.

---

## Standards

The USXGMII IP conforms to the EDCS 1467841-NBASE-T USXGMII: Copper PHY ERS specification, revision 1.4 [Ref 4].

---

## Performance

For transceiver latency, see the *UltraScale Architecture GTY Transceivers User Guide* (UG578) [Ref 8] for information on the transceiver latency.

For full details about performance and resource utilization, visit the [Performance and Resource Utilization web page](#).

## Latency

These measurements are for the core only; they do not include the latency through the transceiver. The latency through the transceiver can be obtained from the relevant user guide

### *Transmit Path Latency*

As measured from the input port `tx_axis_tdata[31:0]` of the transmitter side AXI4-Stream (until that data appears on `tx_serdes_data0[31:0]` on the transceiver interface), the latency through the core for UltraScale™ devices is thirteen periods of the 312.5 MHz transmit clock.

### *Receive Path Latency*

As measured from the input into the core on `rx_serdes_data0[31:0]` until the data appears on `rx_axis_tdata[31:0]` of the receiver side AXI4-Stream interface, the latency through the core in the receive direction is seventeen cycles of the 312.5 MHz receive clock.

## Resource Utilization

For full details about performance and resource utilization, visit the [Performance and Resource Utilization web page](#).

## Port Descriptions

The following tables list the ports for the USXGMII subsystem. These signals are usually found at the wrapper.v hierarchy. When the AXI register interface is included, some of these ports are accessed by means of the registers instead of the broadside bus.

### Transceiver Interface

Table 2-1 shows the transceiver I/O ports for the USXGMII subsystem. Refer to [Clocking and Resets in Chapter 3](#) for details regarding each clock domain.

Table 2-1: Transceiver Interface

Name	Direction	Clock Domain	Description
gtwiz_reset_tx_datapath_*	Input	Async	GT TX reset
gtwiz_reset_rx_datapath_*	Input	Async	GT RX reset
gt_refclk_p	Input		Differential reference clock input for the SerDes, positive phase.
gt_refclk_n	Input		Differential reference clock input for the SerDes, negative phase.
gt_rxp_in_*	Input		Differential reference clock input for the SerDes, positive phase.
gt_rxn_in_*	Input		Differential reference clock input for the SerDes, negative phase.
gt_txp_out_*	Output		Serial data to the line; positive phase of the differential signal.
gt_txn_out_*	Output		Serial data to the line; negative phase of the differential signal.
dclk	Input		Free running clock to GT
gt_loopback_in_*	Input	Async	GT loopback input signal. Refer to the GT user guide. <b>Note:</b> This port is available when the Include GT subcore in core option is selected in the GT Selection and Configuration tab.

Table 2-1: Transceiver Interface (Cont'd)

Name	Direction	Clock Domain	Description
gt_loopback_out_*	Output	Async	GT loopback output signal from AXI4-Lite register map. Refer to the GT user guide. <b>Note:</b> This port is available when Include AXI4-Lite is selected from the Configuration tab and the Include GT subcore in example design option is selected in the GT Selection and Configuration tab.
rxgearboxslip_in_*	Output	RXUSRCLK2	Rxgearboxslip signal from core to GT. <b>Note:</b> This port is available when the Include GT subcore in example design option is selected in the GT Selection and Configuration tab.
rxdatavalid_out_*	Input	RXUSRCLK2	Rx data valid signal from GT to core. <b>Note:</b> This port is available when the Include GT subcore in example design option is selected in the GT Selection and Configuration tab.
rx_serdes_data_out_*	Input	RXUSRCLK2	Rx data signal from GT to core. <b>Note:</b> This port is available when the Include GT subcore in example design option is selected in the GT Selection and Configuration tab.
rxheader_out_*	Input	RXUSRCLK2	Rx header signal from GT to core. <b>Note:</b> This port is available when the Include GT subcore in example design option is selected in the GT Selection and Configuration tab.
rxheadervalid_out_*	Input	RXUSRCLK2	Rx header valid signal from GT to core. <b>Note:</b> This port is available when the Include GT subcore in example design option is selected in the GT Selection and Configuration tab.
tx_serdes_data_in_*	Output	TXUSRCLK2	Tx data signal from core to GT. <b>Note:</b> This port is available when the Include GT subcore in example design option is selected in the GT Selection and Configuration tab.
txheader_in_*	Output	TXUSRCLK2	Tx header signal from core to GT. <b>Note:</b> This port is available when the Include GT subcore in example design option is selected in the GT Selection and Configuration tab.

## AXI4-Stream Interfaces

The USXGMII IP provides a 32-bit AXI4-Stream interface for the TX and RX datapaths. The following subsections describe the clocks and resets and the interface signals in detail.

### AXI4-Stream Clocks and Resets

Table 2-2 shows the clocks and reset signals of the AXI4-Stream interface.

Table 2-2: AXI4-Stream Interface – Clock/Reset Signals

Name	Direction	Clock Domain	Description
tx_clk_out	Output		Transmit clock for the AXI4-Stream interface. All signals between the USXGMII core and the user-side logic are synchronized to the positive edge of this signal. The AXI4-Stream clock is 312.5 MHz.
rx_clk_out	Output		Receive clock for the AXI4-Stream interface. All signals between the USXGMII IP core and the user-side logic are synchronized to the positive edge of this signal. The AXI4-Stream clock is 312.5 MHz. When the RX FIFO is included, this clock will cease to exist and the RX path will be synchronized to tx_clk_out.
tx_reset	Input	Async	Reset for the TX circuits. This signal is active-High (1=reset) and must be held High until clk is stable. The core handles synchronizing the tx_reset input to the appropriate clock domains within the core.
rx_reset	input	Async	Reset for the RX circuits. This signal is active-High (1=reset) and must be held High until clk is stable. The core handles synchronizing the rx_reset input to the appropriate clock domains within the core.

### Transmit AXI4-Stream Interface

Table 2-3 shows the AXI4-Stream transmit interface signals.

Table 2-3: AXI4-Stream Transmit Interface Signals

Name	Direction	Clock Domain	Description
tx_axis_tready	Output	tx_clk_out	AXI4-Stream acknowledge signal to indicate to start the data transfer
tx_axis_tvalid	Input	tx_clk_out	AXI4-Stream Data Valid input
tx_axis_tdata[31:0]	Input	tx_clk_out	AXI4-Stream data (32-bit interface)
tx_axis_tlast	Input	tx_clk_out	AXI4-Stream signal indicating End of Ethernet packet.
tx_axis_tkeep [3:0]	Input	tx_clk_out	AXI4-Stream Data Control (32-bit interface)

Table 2-3: AXI4-Stream Transmit Interface Signals (Cont'd)

Name	Direction	Clock Domain	Description
tx_axis_tuser	Input	tx_clk_out	AXI4-Stream User sideband interface. Equivalent to the tx_errin signal. 1 indicates a bad packet has been transmitted. 0 indicates a good packet has been transmitted.
tx_unfout	Output	tx_clk_out	TX Underflow. When this signal is High, it indicates that there has not been a sufficient data transfer and the Ethernet interface will underflow. This must not be allowed to occur. You must ensure that you transfer data whenever tx_axis_tready is High until you reach the end of the Ethernet frame.

### Data Lane Mapping

For transmit data `tx_axis_tdata[31:0]`, the port is logically divided into lane 0 to lane 3 (See [Table 2-4](#)).

Table 2-4: tx\_axis\_tdata Lane Mapping

Lane/tx_axis_tkeep	tx_axis_tdata[31:0] bits
0	7:0
1	15:8
2	23:16
3	31:24

### Normal Frame Transmission

The timing of a normal frame transfer is shown in [Figure 2-4](#). When the client wants to transmit a frame, it asserts `tx_axis_tvalid` and places the data and control in `tx_axis_tdata` and `tx_axis_tkeep` in the same clock cycle. When this data is accepted by the core, indicated by `tx_axis_tready` being asserted, the client must provide the next cycle of data. If `tx_axis_tready` is not asserted by the core, the client must hold the current valid data value until it is. The end of the packet is indicated to the core by `tx_axis_tlast` asserted for one cycle. The bits of `tx_axis_tkeep` are set appropriately to indicate the number of valid bytes in the final data transfer. `tx_axis_tuser` is also asserted to indicate a bad packet.

After `tx_axis_tlast` is deasserted, any data and control is deemed invalid until `tx_axis_tvalid` is next asserted.

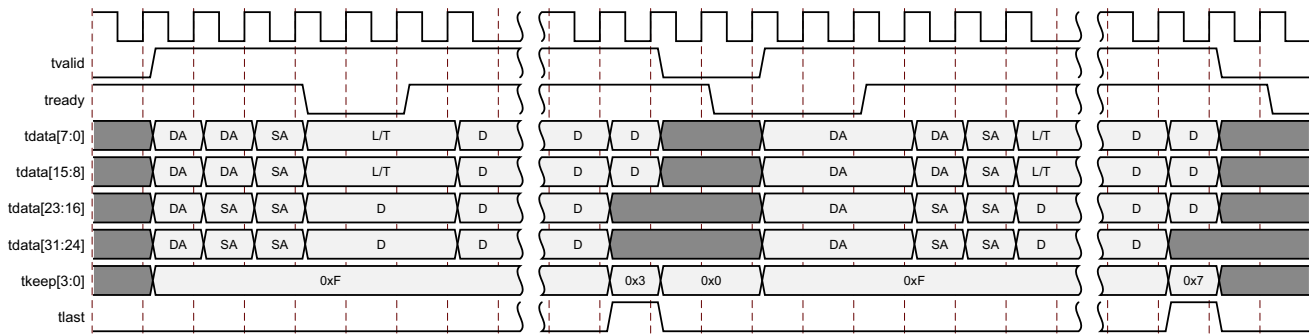

Figure 2-4: Normal Frame Transfer – 32 Bits

### Back to Back Continuous Transfers

Continuous data transfer on the transmit AXI4-Stream interface is possible, as the signal `tx_axis_tvalid` can remain continuously High, with packet boundaries defined solely by `tx_axis_tlast` asserted for the end of the Ethernet packet. However, the core can deassert the `tx_axis_tready` acknowledgment signal to throttle the client data rate as required. See [Figure 2-5](#).

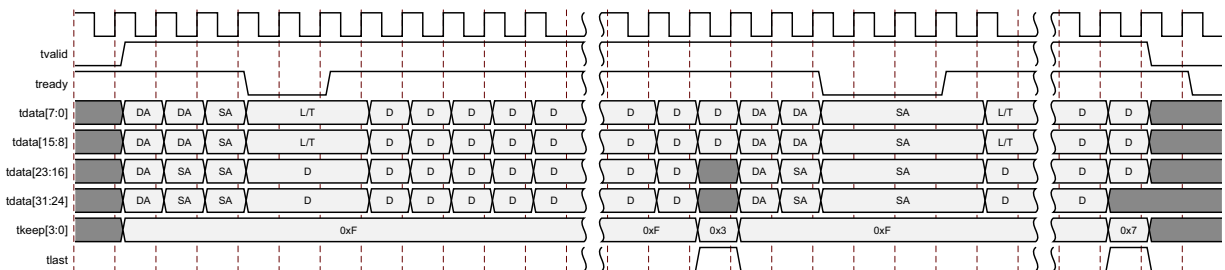

Figure 2-5: Back-to-Back Continuous Transfer on Transmit Client Interface—32-bit

### Aborting a Transmission

The aborted transfer of a packet on the client interface is called an underrun. This can happen if a FIFO in the AXI Transmit client interface empties before a frame is completed.

This is indicated to the core in one of two ways.

- An explicit error in which a frame transfer is aborted by asserting `tx_axis_tuser` High while `tx_axis_tlast` is High. See [Figure 2-7](#).
- An implicit underrun in which a frame transfer is aborted by deasserting `tx_axis_tvalid` without asserting `tx_axis_tlast`.



## Receive AXI4-Stream Interface

Table 2-5 shows the AXI4-Stream receive interface signals.

Table 2-5: AXI4-Stream Receive Interface Signals

Name	Direction	Clock Domain	Description
rx_axis_tvalid	Output	rx_clk_out	AXI4-Stream Data Valid
rx_axis_tdata[31:0]	Output	rx_clk_out	AXI4-Stream Data to upper layer
rx_axis_tlast	Output	rx_clk_out	AXI4-Stream signal indicating an end of packet
rx_axis_tkeep[3:0]	Output	rx_clk_out	AXI4-Stream Data control to upper layer
rx_axis_tuser	Output	rx_clk_out	AXI4-Stream User Sideband interface 1 indicates a bad packet has been received 0 indicates a good packet has been received

### Data Lane Mapping

For receive data `rx_axis_tdata`, the port is divided into lane 0 to lane 3. See Table 2-6.

Table 2-6: rx\_axis\_tdata Lane Mapping

Lane/rx_axis_tkeep	rx_axis_tdata bits
0	7:0
1	15:8
2	23:16
3	31:24

### Normal Frame Reception

The timing of a normal inbound frame transfer is represented in Figure 2-6. The client must be prepared to accept data at any time; there is no buffering within the core to allow for latency in the receive client. When frame reception begins, data is transferred on consecutive clock cycles to the receive client.

During frame reception, `rx_axis_tvalid` is asserted to indicate that valid frame data is being transferred to the client on `rx_axis_tdata`. All bytes are always valid throughout the frame, as indicated by all `rx_axis_tkeep` bits being set to 1, except during the final transfer of the frame when `rx_axis_tlast` is asserted. During this final transfer of data for a frame, `rx_axis_tkeep` bits indicate the final valid bytes of the frame using the mapping from above.

The valid bytes of the final transfer always lead out from `rx_axis_tdata[7:0]` (`rx_axis_tkeep[0]`) because Ethernet frame data is continuous and is received least significant byte first.

The `rx_axis_tlast` is asserted and `rx_axis_tuser` is deasserted, along with the final bytes of the transfer, only after all the frame checks are completed. This is after the frame check sequence (FCS) field has been received. The core keeps the `rx_axis_tuser` signal deasserted to indicate that the frame was successfully received and that the frame should be analyzed by the client. This is also the end of the packet signaled by `rx_axis_tlast` asserted for one cycle.

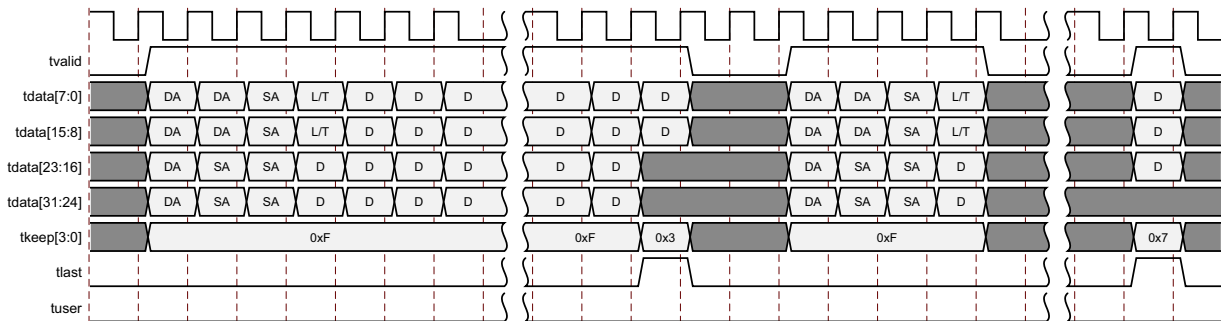

Figure 2-6: Normal Frame Reception – 32 Bits

### Frame Reception with Errors

The case of an unsuccessful frame reception (for example, a runt frame or a frame with an incorrect FCS) is shown in Figure 2-7. In this case the bad frame is received and the signal `rx_axis_tuser` is asserted to the client at the end of the frame. It is then the responsibility of the client to drop the data already transferred for this frame.

The following conditions cause the assertion of `rx_axis_tlast` along with `rx_axis_tuser = 1` signifying a bad frame.

- FCS errors occur.
- Packets are shorter than 64 bytes (undersize or fragment frames).
- Frames of length greater than the maximum transmission unit (MTU) size programmed are received.
- Any control frame that is received is not exactly the minimum frame length.
- The XGMII data stream contains error codes.

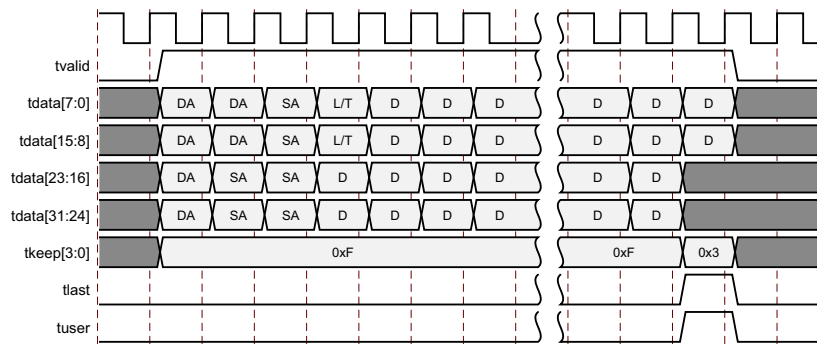

Figure 2-7: Frame Reception with Errors – 32 Bits

### AXI4-Stream Control and Status Ports

Table 2-7: AXI4-Stream Interface – TX Path Control/Status Signals

Name	Direction	Clock Domain	Description
ctl_tx_enable	Input	tx_clk_out	TX Enable. When sampled as a 1, this signal is used to enable the transmission of data. When sampled as a 0, only IDLEs are transmitted by the core. This input should not be set to 1 until the receiver it is sending data to is fully synchronized and ready to receive data. (that is, the receiver on the link partner is not sending a remote fault condition.) Otherwise, loss of data can occur. If this signal is set to 0 while a packet is being transmitted, the current packet transmission is completed and then the core stops transmitting any more packets.
ctl_tx_custom_preamble_enable	Input	tx_clk_out	When asserted, this signal enables the use of tx_preamblein as a custom preamble instead of inserting a standard preamble.
tx_preamblein[55:0]	Input	tx_clk_out	This is the custom preamble which is a separate input port rather than being in-line with the data. It should be valid during the start of the packet.

Table 2-7: AXI4-Stream Interface – TX Path Control/Status Signals (Cont'd)

Name	Direction	Clock Domain	Description
ctl_tx_fcs_ins_enable	Input	tx_clk_out	Enable FCS insertion by the TX core. If set to 0, the core does not add FCS to the packet. If set to 1, the core calculates and adds FCS to the packet. This input cannot be dynamically changed between packets.
ctl_tx_send_lfi	Input	tx_clk_out	Transmit Local Fault Indication (LFI) code word. Takes precedence over Remote Fault Indication (RFI).
ctl_tx_send_rfi	Input	tx_clk_out	Transmit Remote Fault Indication (RFI) code word. If sampled as a 1, the TX path transmits only RFI code words. This input should be set to 1 until the RX path is fully synchronized and is ready to accept data from the link partner.
ctl_tx_send_idle	Input	tx_clk_out	Transmit IDLE code words. If sampled as a 1, the TX path only transmits IDLE code words. This input should be set to 1 when the partner is sending RFI code words.
ctl_tx_send_umii_lfi	Input	tx_clk_out	If set to 1, the TX MAC/PCS will send LFI code words onto the line.
ctl_tx_send_umii_rfi	Input	tx_clk_out	If UMII LFI code set to 1, the TX MAC/PCS will send UMII RFI code words onto the line.
ctl_tx_ignore_fcs	Input	tx_clk_out	Enable FCS error checking at the AXI4-Stream interface by the TX core. This input only has effect when <code>ctl_tx_fcs_ins_enable</code> is Low. If set to 0 and a packet with bad FCS is being transmitted, it is not binned as good. If set to 1, a packet with bad FCS is binned as good. The error is flagged on the signals <code>stat_tx_bad_fcs</code> and <code>stomped_fcs</code> and the packet is transmitted as it was received. <b>Note:</b> Statistics are reported as if there was no FCS error.

Table 2-7: AXI4-Stream Interface – TX Path Control/Status Signals (Cont'd)

Name	Direction	Clock Domain	Description
ctl_usxgmii_rate[2:0]	Input	static	User selectable USXGMII rate, valid when ctl_umii_an_bypass = 1; otherwise the USXGMII rate is determined through auto-negotiation. 3'b000 = 10 Mb/s 3'b001 = 100 Mb/s 3'b010 = 1 Gb/s 3'b011 = 10 Gb/s 3'b100 = 2.5 Gb/s 3'b101 = 5 Gb/s
ctl_umii_an_mr_adv_ability[15:0]	Input	tx_clk_out	This bus should be driven with the desired link advertised ability for the Auto-Negotiation function, that maps to the UsxgmiiChannellInfo message's config field. [15] = Link Status [14:13] = 2'b00 [12] = Duplex Mode. 1 = Full Duplex, 0=Half Duplex [11:9] = Speed; for more information, refer table f N-base-T_usxgmii rev1.4 [8] = 1'b0 (EEE capability; Not supported.) [7] = 1'b0 (EEE clock stop capability; Not supported) [6:1] = 0x0 Reserved [0] = USXGMII
ctl_umii_an_mr_an_enable	Input	tx_clk_out	Refer to <a href="#">Auto-Negotiation</a> for the use of these signals in the auto-negotiation operation.
ctl_umii_an_mr_restart_an	Input	tx_clk_out	
ctl_umii_an_mr_main_reset	Input	tx_clk_out	
ctl_umii_an_link_timer_config[3:0]	Input	tx_clk_out	
ctl_umii_an_bypass	Input	tx_clk_out	
stat_umii_an_mr_an_complete	Output	rx_serdes_clk	USXGMII auto-negotiation complete status signals.
stat_umii_an_mr_lp_adv_ability[15:0]	Output	rx_serdes_clk	Auto-negotiation ability advertisement from Link Partner.
stat_umii_an_mr_np_able	Output	rx_serdes_clk	Indicates next page capability. the design not supporting next page capability. it is set to 0.

Table 2-8: AXI4-Stream Interface – RX path Control/Status Signals

Name	Direction	Clock Domain	Description
ctl_rx_enable	Input	rx_clk_out	RX enable. For normal operation this input must be set to 1. When set to 0, after the RX completes the reception of the current packet (if any), it stops receiving packets by keeping the PCS from decoding incoming data. In this mode, there are no statistics reported and the AXI4-Stream interface is idle.
ctl_rx_custom_preamble_enable	Input	rx_clk_out	When asserted, this signal causes the side band of a packet presented on the AXI4-Stream to be the preamble as it appears on the line.
rx_preambleout[55:0]	Output	rx_clk_out	This is the preamble, and now a separate output instead of inline with data.
ctl_rx_delete_fcs	Input	rx_clk_out	Enable FCS removal by the RX core. If set to 0, the core does not remove the FCS of the incoming packet. If set to 1, the core deletes the FCS to the received packet. <b>Note:</b> FCS is not deleted for packets that are less than 5 bytes. This input should only be changed while the corresponding reset input is asserted.
ctl_rx_ignore_fcs	Input	rx_clk_out	Enable FCS error checking at the AXI4-Stream interface by the RX core. If set to 0, a packet received with an FCS error is indicated as an errored frame (rx_axis_tuser=1 when rx_axis_tlast=1) If set to 1, the core does not flag an FCS error at the AXI4-Stream Interface. <b>Note:</b> The statistics are reported as if the packet is good. The signal stat_rx_bad_fcs, however reports the error.
ctl_rx_max_packet_len[14:0]	Input	rx_clk_out	Any packet longer than this value is considered to be oversized. If a packet has a size greater than this value, it is truncated to this value and the rx_axis_tuser signal is asserted along with the rx_axis_tlast signal. ctl_rx_max_packet_len[14] is reserved and must be set to 0.
ctl_rx_min_packet_len[7:0]	Input	rx_clk_out	Any packet shorter than this value is considered to be undersized. If a packet has a size shorter than this value, the rx_axis_tuser signal is asserted along with the rx_axis_tlast signal.

Table 2-8: AXI4-Stream Interface – RX path Control/Status Signals (Cont'd)

Name	Direction	Clock Domain	Description
ctl_rx_check_sfd	Input	rx_clk_out	When asserted, this input causes the MAC to check the Start of Frame Delimiter (SFD) of the received frame.
ctl_rx_check_preamble	Input	rx_clk_out	When asserted, this input causes the MAC to check the preamble of the received frame. When rx custom preamble is enabled, both ctl_rx_check_sfd, crl_rx_check_preamble are required to be disabled.
ctl_rx_force_resync	Input	rx_clk_out	RX force resynchronization input. This signal is used to force the RX path to reset and resynchronize. A value of 1 forces the reset operation. A value of 0 allows normal operation. <b>Note:</b> This should normally be Low and should only be pulsed. (1 cycle minimum pulse)
stat_rx_local_fault	Output	rx_clk_out	This output is High when stat_rx_internal_local_fault or stat_rx_received_local_fault is asserted. This output is level sensitive.
stat_rx_umii_local_fault	Output	rx_clk_out	USXGMII received UMII local fault
stat_rx_remote_fault	Output	rx_clk_out	Remote fault indication status. If this bit is sampled as 1, indicates a remote fault condition was detected. If this bit is sampled as 0, remote fault condition does not exist. This output is level sensitive.
stat_rx_umii_remote_fault	Output	rx_clk_out	USXGMII has received UMII Remote fault.
stat_rx_internal_local_fault	Output	rx_clk_out	High when an internal local fault is generated due to any of the following: test pattern generation or high bit error rate (BER). <b>Note:</b> Remains High as long as the fault condition persists.
stat_rx_received_local_fault	Output	rx_clk_out	High when enough local fault words are received from the link partner to trigger a fault condition as specified by the IEEE fault state machine. <b>Note:</b> Remains High as long as the fault condition persists.
stat_rx_block_lock	Output	rx_clk_out	Block lock status. A value of 1 indicates that block lock is achieved as defined in Clause 49.2.14 and management data input/output (MDIO) register 3.32.0. This output is level sensitive.

Table 2-8: AXI4-Stream Interface – RX path Control/Status Signals (Cont'd)

Name	Direction	Clock Domain	Description
stat_rx_framing_err_valid	Output	rx_clk_out	Valid indicator for stat_rx_framing_err. When sampled as a 1, the value on stat_rx_framing_err is valid.
stat_rx_framing_err[2:0]	Output	rx_clk_out	The RX sync header bits framing error is a bus that indicates how many sync header errors were received. The value of the bus is only valid when the stat_rx_framing_err_valid is a 1. The values can be updated at any time and are intended to be used as increment values for sync header error counters.
stat_rx_hi_ber	Output	rx_clk_out	High Bit Error Rate (BER) indicator. When set to 1, the BER is too high as defined by IEEE Std. 802.3. Corresponds to management data input/output (MDIO) register bit 3.32.1as defined in Clause 49.2.14. This output is level sensitive.



## Miscellaneous Status/Control Signals

Table 2-9 shows the miscellaneous status and control signals.

Table 2-9: Miscellaneous Status/Control Signals

Name	Direction	Clock Domain	Description
ctl_tx_test_pattern_enable	Input	tx_clk_out	Test pattern generation enable for the TX core. A value of 1 enables test mode. Corresponds to MDIO register bit 3.42.3 as defined in clause 45. Takes second precedence.
ctl_tx_test_pattern_select	Input	tx_clk_out	Corresponds to MDIO register bit 3.42.1 as defined in Clause 45
ctl_tx_data_pattern_select	Input	tx_clk_out	Corresponds to MDIO register bit 3.42.0 as defined in Clause 45
ctl_tx_test_pattern_seed_a[57:0]	Input	tx_clk_out	Corresponds to MDIO registers 3.34 through to 3.37 as defined in Clause 45
ctl_tx_test_pattern_seed_b[57:0]	Input	tx_clk_out	Corresponds to MDIO registers 3.38 through to 3.41 as defined in Clause 45
ctl_rx_test_pattern_enable	Input	rx_clk_out	Test pattern enable for the RX core. A value of 1 enables test mode. Corresponds to MDIO register bit 3.42.2 as defined in Clause 45. Takes second precedence.
ctl_rx_data_pattern_select	Input	rx_clk_out	Corresponds to MDIO register bit 3.42.0 as defined in Clause 45.
stat_rx_test_pattern_mismatch	Output	rx_clk_out	Test pattern mismatch increment. A non-zero value in any cycle indicates how many mismatches occurred for the test pattern in the RX core. This output is only active when ctl_rx_test_pattern is set to a 1. This output can be used to generate MDIO register as defined in Clause 45. This output is pulsed for one clock cycle.
ctl_local_loopback	Input	Async	Sets GT in near-end PMA loopback
ctl_rx_process_lfi	Input	rx_clk_out	When this input is set to 1, the RX core expects and processes LF control codes coming in from the transceiver. When set to 0, the RX core ignores LF control codes coming in from the transceiver.
stat_rx_valid_ctrl_code	Output	rx_clk_out	Indicates that a PCS block with a valid control code was received.

## Statistics Interface Ports

Table 2-10 and Table 2-11 show the statistics interface ports for the RX and TX paths respectively.

Table 2-10: Statistics Interface Ports – RX

Name	Direction	Clock Domain	Description
stat_rx_bad_code	Output	rx_clk_out	Increment for 64B/66B code violations. This signal indicates that the RX PCS receive state machine is in the RX_E state as specified by IEEE Std 802.3. This output can be used to generate MDIO register as defined in Clause 45.
stat_rx_total_packets[1:0]	Output	rx_clk_out	Increment for the total number of packets received.
stat_rx_total_good_packets	Output	rx_clk_out	Increment for the total number of good packets received. This value is non-zero only when a packet is received completely and contains no errors.
stat_rx_total_bytes[3:0]	Output	rx_clk_out	Increment for the total number of bytes received.
stat_rx_total_good_bytes[13:0]	Output	rx_clk_out	Increment for the total number of good bytes received. This value is non-zero only when a packet is received completely and contains no errors.
stat_rx_packet_small	Output	rx_clk_out	Increment for all packets that are less than 64 bytes long. Packets that are less than 64 bytes are dropped.
stat_rx_jabber	Output	rx_clk_out	Increment for packets longer than <code>ctl_rx_max_packet_len</code> with bad FCS.
stat_rx_packet_large	Output	rx_clk_out	Increment for all packets that are more than 9215 bytes long.
stat_rx_oversize	Output	rx_clk_out	Increment for packets longer than <code>ctl_rx_max_packet_len</code> with good FCS.
stat_rx_undersize	Output	rx_clk_out	Increment for packets shorter than <code>ctl_rx_min_packet_len</code> with good FCS.
stat_rx_toolong	Output	rx_clk_out	Increment for packets longer than <code>ctl_rx_max_packet_len</code> with good and bad FCS.
stat_rx_fragment	Output	rx_clk_out	Increment for packets shorter than <code>ctl_rx_min_packet_len</code> with bad FCS.
stat_rx_packet_64_bytes	Output	rx_clk_out	Increment for good and bad packets received that contain 64 bytes.
stat_rx_packet_65_127_bytes	Output	rx_clk_out	Increment for good and bad packets received that contain between 65 and 127 bytes.

Table 2-10: Statistics Interface Ports – RX (Cont'd)

Name	Direction	Clock Domain	Description
stat_rx_packet_128_255_bytes	Output	rx_clk_out	Increment for good and bad packets received that contain between 128 and 255 bytes.
stat_rx_packet_256_511_bytes	Output	rx_clk_out	Increment for good and bad packets received that contain between 256 and 511 bytes.
stat_rx_packet_512_1023_bytes	Output	rx_clk_out	Increment for good and bad packets received that contain between 512 and 1023 bytes.
stat_rx_packet_1024_1518_bytes	Output	rx_clk_out	Increment for good and bad packets received that contain between 1024 and 1518 bytes.
stat_rx_packet_1519_1522_bytes	Output	rx_clk_out	Increment for good and bad packets received that contain between 1519 and 1522 bytes.
stat_rx_packet_1523_1548_bytes	Output	rx_clk_out	Increment for good and bad packets received that contain between 1523 and 1548 bytes.
stat_rx_packet_1549_2047_bytes	Output	rx_clk_out	Increment for good and bad packets received that contain between 1549 and 2047 bytes.
stat_rx_packet_2048_4095_bytes	Output	rx_clk_out	Increment for good and bad packets received that contain between 2048 and 4095 bytes.
stat_rx_packet_4096_8191_bytes	Output	rx_clk_out	Increment for good and bad packets received that contain between 4096 and 8191 bytes.
stat_rx_packet_8192_9215_bytes	Output	rx_clk_out	Increment for good and bad packets received that contain between 8192 and 9215 bytes.
stat_rx_bad_fcs [1:0]	Output	rx_clk_out	<p>When this signal is positive, it indicates that the error detection logic has identified mismatches between the expected and received value of CRC32 in the received packet.</p> <p>When a CRC error is detected, the received packet is marked as containing an error and is sent with rx_axis_tuser asserted for the last transfer (the cycle with rx_axis_last asserted), unless ctl_rx_ignore_fcs is asserted. This signal is asserted for one clock cycle for each CRC32 error detected.</p>

Table 2-10: Statistics Interface Ports – RX (Cont'd)

Name	Direction	Clock Domain	Description
stat_rx_packet_bad_fcs	Output	rx_clk_out	Increment for packets between 64 and <code>ctl_rx_max_packet_len</code> bytes that have Frame Check Sequence (FCS) errors.
stat_rx_stomped_fcs [1:0]	Output	rx_clk_out	Stomped FCS indicator. The value on this bus indicates the packets received with a stomped FCS. A stomped FCS is defined as the bitwise inverse of the expected good FCS. This output is pulsed for one clock cycle to indicate the stomped condition. Note that pulses can occur in back-to-back cycles.
stat_rx_unicast	Output	rx_clk_out	Increment for good unicast packets.
stat_rx_multicast	Output	rx_clk_out	Increment for good multicast packets.
stat_rx_broadcast	Output	rx_clk_out	Increment for good broadcast packets.
stat_rx_vlan	Output	rx_clk_out	Increment for good 802.1Q tagged VLAN packets.
stat_rx_pause	Output	rx_clk_out	Increment for 802.3x MAC Pause Packet with good FCS.
stat_rx_user_pause	Output	rx_clk_out	Increment for priority based pause packets with good FCS.
stat_rx_inrangeerr	Output	rx_clk_out	Increment for packets with Length field error but with good FCS.
stat_rx_bad_preamble	Output	rx_clk_out	Increment for packets received with bad preamble. This signal indicates if the Ethernet packet received was preceded by a valid preamble. A value of 1 indicates that an invalid preamble was received.
stat_rx_bad_sfd	Output	rx_clk_out	Increment for packets received with bad SFD. This signal indicates if the Ethernet packet received was preceded by a valid SFD. A value of 1 indicates that an invalid SFD was received.
stat_rx_got_signal_os	Output	rx_clk_out	Signal OS indication. If this bit is sampled as a 1, it indicates that a signal OS word was received. <b>Note:</b> Signal OS should not be received in an Ethernet network.
stat_rx_truncated	Output	rx_clk_out	Packet truncation indicator. A value of 1 indicates that the current packet in flight is truncated due to its length exceeding <code>ctl_rx_max_packet_len[14:0]</code> . This output is pulsed for one clock cycle to indicate the truncated condition. Pulses can occur in back to back cycles.

Table 2-11: Statistics Interface – TX path

Name	Direction	Clock Domain	Description
stat_tx_total_packets	Output	tx_clk_out	Increment for total number of packets transmitted.
stat_tx_total_bytes[2:0]	Output	tx_clk_out	Increment for total number of bytes transmitted.
stat_tx_total_good_packets	Output	tx_clk_out	Increment for the total number of good packets transmitted.
stat_tx_total_good_bytes[13:0]	Output	tx_clk_out	Increment for the total number of good bytes transmitted. This signal is non-zero only when a packet is transmitted completely and contains no errors.
stat_tx_packet_64_bytes	Output	tx_clk_out	Increment for good and bad packets transmitted that contain 64 bytes.
stat_tx_packet_65_127_bytes	Output	tx_clk_out	Increment for good and bad packets transmitted that contain between 65 and 127 bytes.
stat_tx_packet_128_255_bytes	Output	tx_clk_out	Increment for good and bad packets transmitted that contain between 128 and 255 bytes.
stat_tx_packet_256_511_bytes	Output	tx_clk_out	Increment for good and bad packets transmitted that contain between 256 and 511 bytes.
stat_tx_packet_512_1023_bytes	Output	tx_clk_out	Increment for good and bad packets transmitted that contain between 512 and 1023 bytes.
stat_tx_packet_1024_1518_bytes	Output	tx_clk_out	Increment for good and bad packets transmitted that contain between 1024 and 1518 bytes.
stat_tx_packet_1519_1522_bytes	Output	tx_clk_out	Increment for good and bad packets transmitted that contain between 1519 and 1522 bytes.
stat_tx_packet_1523_1548_bytes	Output	tx_clk_out	Increment for good and bad packets transmitted that contain between 1523 and 1548 bytes.
stat_tx_packet_1549_2047_bytes	Output	tx_clk_out	Increment for good and bad packets transmitted that contain between 1549 and 2047 bytes.
stat_tx_packet_2048_4095_bytes	Output	tx_clk_out	Increment for good and bad packets transmitted that contain between 2048 and 4095 bytes.
stat_tx_packet_4096_8191_bytes	Output	tx_clk_out	Increment for good and bad packets transmitted that contain between 4096 and 8191 bytes.

Table 2-11: Statistics Interface – TX path (Cont'd)

Name	Direction	Clock Domain	Description
stat_tx_packet_8192_9215_bytes	Output	tx_clk_out	Increment for good and bad packets transmitted that contain between 8192 and 9215 bytes.
stat_tx_packet_small	Output	tx_clk_out	Increment for all packets that are less than 64 bytes long.
stat_tx_packet_large	Output	tx_clk_out	Increment for all packets that are more than 9215 bytes long.
stat_tx_unicast	Output	tx_clk_out	Increment for good unicast packets.
stat_tx_multicast	Output	tx_clk_out	Increment for good multicast packets.
stat_tx_broadcast	Output	tx_clk_out	Increment for good broadcast packets.
stat_tx_vlan	Output	tx_clk_out	Increment for good 802.1Q tagged VLAN packets.
stat_tx_pause	Output	tx_clk_out	Increment for 802.3x MAC Pause Packet with good FCS.
stat_tx_user_pause	Output	tx_clk_out	Increment for Priority based pause packets with good FCS.
stat_tx_bad_fcs	Output	tx_clk_out	Increment for packets greater than 64 bytes that have FCS errors.
stat_tx_frame_error	Output	tx_clk_out	Increment for packets with tx_axis_tuser set to indicate an End of Packet (EOP) abort.
stat_tx_local_fault	Output	tx_clk_out	A value of 1 indicates the receive decoder state machine is in the TX_INIT state. This output is level sensitive.

## Pause Interface

Table 2-12 through Table 2-13 show the Pause interface I/O ports.

Table 2-12: Pause Interface – Control Ports

Name	Direction	Clock Domain	Description
ctl_rx_pause_enable[8:0]	Input	rx_clk_out	RX pause enable signal. This input is used to enable the processing of the pause quanta for the corresponding priority. <b>Note:</b> This signal only affects the RX user interface and not the pause processing logic
ctl_tx_pause_enable[8:0]	Input	tx_clk_out	TX pause enable signal. This input is used to enable the processing of the pause quanta for the corresponding priority. This signal gates transmission of pause packets.

### Pause Interface – TX

Table 2-13: Pause Interface – TX path

Name	Direction	Clock Domain	Description
ctl_tx_pause_req[8:0]	Input	tx_clk_out	If a bit of this bus is set to 1, the core transmits a pause packet using the associated quanta value on the ctl_tx_pause_quanta[8:0][15:0] bus. If bit[8] is set to 1, a global pause packet is transmitted. All other bits cause a priority pause packet to be transmitted.
ctl_tx_resend_pause	Input	tx_clk_out	Re-transmit pending pause packets. When this input is sampled as 1, all pending pause packets are retransmitted as soon as possible (that is, after the current packet in flight is completed) and the retransmit counters are reset. This input should be pulsed to 1 for one cycle at a time.
ctl_tx_pause_quanta[8:0][15:0]	Input	tx_clk_out	These nine buses indicate the quanta to be transmitted for each of the eight priorities in priority based and global pause operations. The value for ctl_tx_pause_quanta[8] is used for global pause operation. All other values are used for priority based pause operation.

Table 2-13: Pause Interface – TX path (Cont'd)

Name	Direction	Clock Domain	Description
ctl_tx_pause_refresh_timer[8:0][15:0]	Input	tx_clk_out	These nine buses set the retransmission time of pause packets for each of the eight priorities in priority based pause operation and the global pause operation. The values for ctl_tx_pause_refresh_timer[8] are used for global pause operation. All other values are used for priority pause operation.
ctl_tx_da_gpp[47:0]	Input	tx_clk_out	Destination address for transmitting global pause packets.
ctl_tx_sa_gpp[47:0]	Input	tx_clk_out	Source address for transmitting global pause packets.
ctl_tx_ethertype_gpp[15:0]	Input	tx_clk_out	Ethertype for transmitting global pause packets.
ctl_tx_opcode_gpp[15:0]	Input	tx_clk_out	Opcode for transmitting global pause packets.
ctl_tx_da_ppp[47:0]	Input	tx_clk_out	Destination address for transmitting priority pause packets.
ctl_tx_sa_ppp[47:0]	Input	tx_clk_out	Source address for transmitting priority pause packets.
ctl_tx_ethertype_ppp[15:0]	Input	tx_clk_out	Ethertype for transmitting priority pause packets.
ctl_tx_opcode_ppp[15:0]	Input	tx_clk_out	Opcode for transmitting priority pause packets.
stat_tx_pause_valid[8:0]	Output	tx_clk_out	If a bit of this bus is set to 1, the core has transmitted a pause packets. If bit [8] is set to 1, a global pause packet is transmitted. All other bits cause a priority pause packet to be transmitted.



## Pause Interface – RX

Table 2-14: Pause Interface – RX

Name	Direction	Clock Domain	Description
ctl_rx_pause_ack[8:0]	Input	rx_clk_out	Pause acknowledge signal. This bus is used to acknowledge the receipt of the pause frame from the user logic.
ctl_rx_check_ack	Input	rx_clk_out	Wait for acknowledge. If this input is set to 1, the core uses the ctl_rx_pause_ack[8:0] bus for pause processing. If this input is set to 0, ctl_rx_pause_ack[8:0] is not used.
ctl_rx_enable_gcp	Input	rx_clk_out	A value of 1 enables global control packet processing.
ctl_rx_check_mcast_gcp	Input	rx_clk_out	A value of 1 enables global control multicast destination address processing.
ctl_rx_check_ucast_gcp	Input	rx_clk_out	A value of 1 enables global control unicast destination address processing.
ctl_rx_pause_da_ucast[47:0]	Input	rx_clk_out	Unicast destination address for pause processing.
ctl_rx_check_sa_gcp	Input	rx_clk_out	A value of 1 enables global control source address processing.
ctl_rx_pause_sa[47:0]	Input	rx_clk_out	Source address for pause processing.
ctl_rx_check_etype_gcp	Input	rx_clk_out	A value of 1 enables global control ethertype processing.
ctl_rx_etype_gcp[15:0]	Input	rx_clk_out	Ethertype field for global control processing
ctl_rx_check_opcode_gcp	Input	rx_clk_out	A value of 1 enables global control opcode processing.
ctl_rx_opcode_min_gcp[15:0]	Input	rx_clk_out	Minimum global control opcode value.
ctl_rx_opcode_max_gcp[15:0]	Input	rx_clk_out	Maximum global control opcode value.
ctl_rx_enable_pcp	Input	rx_clk_out	A value of 1 enables priority control packet processing.
ctl_rx_check_mcast_pcp	Input	rx_clk_out	A value of 1 enables priority control multicast destination address processing.
ctl_rx_check_ucast_pcp	Input	rx_clk_out	A value of 1 enables priority control unicast destination address processing.
ctl_rx_pause_da_mcast[47:0]	Input	rx_clk_out	Multicast destination address for pause processing.
ctl_rx_check_sa_pcp	Input	rx_clk_out	A value of 1 enables priority control source address processing.
ctl_rx_check_etype_pcp	Input	rx_clk_out	A value of 1 enables priority control ethertype processing.
ctl_rx_etype_pcp[15:0]	Input	rx_clk_out	Ethertype field for priority control processing.

Table 2-14: Pause Interface – RX (Cont'd)

Name	Direction	Clock Domain	Description
ctl_rx_check_opcode_pcp	Input	rx_clk_out	A value of 1 enables priority control opcode processing.
ctl_rx_opcode_min_pcp[15:0]	Input	rx_clk_out	Minimum priority control opcode value.
ctl_rx_opcode_max_pcp[15:0]	Input	rx_clk_out	Maximum priority control opcode value.
ctl_rx_enable_gpp	Input	rx_clk_out	A value of 1 enables global pause packet processing.
ctl_rx_check_mcast_gpp	Input	rx_clk_out	A value of 1 enables global pause multicast destination address processing.
ctl_rx_check_ucast_gpp	Input	rx_clk_out	A value of 1 enables global pause unicast destination address processing.
ctl_rx_check_sa_gpp	Input	rx_clk_out	A value of 1 enables global pause source address processing.
ctl_rx_check_etype_gpp	Input	rx_clk_out	A value of 1 enables global pause ethertype processing.
ctl_rx_etype_gpp[15:0]	Input	rx_clk_out	Ethertype field for global pause processing.
ctl_rx_check_opcode_gpp	Input	rx_clk_out	A value of 1 enables global pause opcode processing.
ctl_rx_opcode_gpp[15:0]	Input	rx_clk_out	Global pause opcode value.
ctl_rx_enable_ppp	Input	rx_clk_out	A value of 1 enables priority pause packet processing.
ctl_rx_check_mcast_ppp	Input	rx_clk_out	A value of 1 enables priority pause multicast destination address processing.
ctl_rx_check_ucast_ppp	Input	rx_clk_out	A value of 1 enables priority pause unicast destination address processing.
ctl_rx_check_sa_ppp	Input	rx_clk_out	A value of 1 enables priority pause source address processing.
ctl_rx_check_etype_ppp	Input	rx_clk_out	A value of 1 enables priority pause ethertype processing.
ctl_rx_etype_ppp[15:0]	Input	rx_clk_out	Ethertype field for priority pause processing.
ctl_rx_check_opcode_ppp	Input	rx_clk_out	A value of 1 enables priority pause opcode processing.
ctl_rx_opcode_ppp[15:0]	Input	rx_clk_out	Priority pause opcode value.
ctl_rx_forward_control	Input	rx_clk_out	A value of 1 indicates that the core forwards control packets. A value of 0 causes core to drop control packets.

Table 2-14: Pause Interface – RX (Cont'd)

Name	Direction	Clock Domain	Description
stat_rx_pause_valid [8:0]	Output	rx_clk_out	Indicates that a pause packet was received and the associated quanta on the stat_rx_pause_quanta[8:0][15:0] bus is valid and must be used for pause processing. If an 802.3x MAC Pause packet is received, bit [8] is set to 1.
stat_rx_pause_quanta[8:0][15:0]	Output	rx_clk_out	These nine buses indicate the quanta received for each of the eight priorities in priority based pause operation and global pause operation. If an 802.3x MAC Pause packet is received, the quanta is placed in value[8].
stat_rx_pause_req [8:0]	Output	rx_clk_out	Pause request signal. When the RX receives a valid pause frame, it sets the corresponding bit of this bus to 1 and keep it at 1 until the pause packet has been processed.

## Register Space

The USXGMII IP core can be optionally configured with AXI4-Lite registers to access the configuration and status signals.

## AXI4-Lite Ports

Table 2-15 describes the port list for the AXI processor interface.

Table 2-15: AXI4-Lite Ports

Name	Direction	Clock Domain	Description
s_axi_aclk	Input		AXI4-Lite Clock
s_axi_aresetn	Input		Asynchronous active-Low Reset
s_axi_awaddr[31:0]	Input	s_axi_aclk	Write Address Bus
s_axi_awvalid	Input	s_axi_aclk	Write Address Valid
s_axi_awready	Output	s_axi_aclk	Write address acknowledge
s_axi_wdata[31:0]	Input	s_axi_aclk	Write Data Bus
s_axi_wstrb[3:0]	Input	s_axi_aclk	Strobe signal for the data bus byte lane
s_axi_wvalid	Output	s_axi_aclk	Write data valid
s_axi_wready	Output	s_axi_aclk	Write data acknowledge
s_axi_bresp[1:0]	Output	s_axi_aclk	Write transaction response
s_axi_bvalid	Output	s_axi_aclk	Write response valid

Table 2-15: AXI4-Lite Ports (Cont'd)

Name	Direction	Clock Domain	Description
s_axi_bready	Input	s_axi_aclk	Write response acknowledge
s_axi_araddr[31:0]	Input	s_axi_aclk	Read address bus
s_axi_arvalid	Input	s_axi_aclk	Read address valid
s_axi_arready	Output	s_axi_aclk	Read address acknowledge
s_axi_rdata[31:0]	Output	s_axi_aclk	Read data output
s_axi_rresp[1:0]	Output	s_axi_aclk	Read data response
s_axi_rvalid	Output	s_axi_aclk	Read data/response valid
s_axi_rready	Input	s_axi_aclk	Read data acknowledge
pm_tick	Input	s_axi_aclk	Top level signal to read statistics counters; requires MODE_REG[30] (i.e. tick_reg_mode_sel) to be set to 0.

Additional information for the operation of the AXI4 bus is found in Xilinx AXI Memory-Mapped Protocol version 1.8.

As noted previously, the top-level signal `pm_tick` can be used to read statistics counters instead of the configuration register `TICK_REG`. In this case, configuration register `MODE_REG` bit 30 should be set to 0. If set to 1, `tick_reg` is used to read the statistics counters.

## Configuration Register Map

The configuration space provides software with the ability to configure the IP core for various use cases. Certain features are optional and the assigned register might not exist in a particular variant, in which case the applicable registers are considered RESERVED.

Table 2-16: Configuration Register Map

Hex Address	Register name/link to Description	Notes
0x0000	<a href="#">GT_RESET_REG: 0000</a>	
0x0004	<a href="#">RESET_REG: 0004</a>	
0x0008	<a href="#">MODE_REG: 0008</a>	
0x000C	<a href="#">CONFIGURATION_TX_REG1: 000C</a>	
0x0014	<a href="#">CONFIGURATION_RX_REG1: 0014</a>	
0x0018	<a href="#">CONFIGURATION_RX_MTU: 0018</a>	
0x0020	<a href="#">TICK_REG: 0020</a>	
0x0024	<a href="#">CONFIGURATION_REVISION_REG: 0024</a>	
0x0028	<a href="#">CONFIGURATION_TX_TEST_PAT_SEED_A_LSB: 0028</a>	
0x002C	<a href="#">CONFIGURATION_TX_TEST_PAT_SEED_A_MSB: 002C</a>	
0x0030	<a href="#">CONFIGURATION_TX_TEST_PAT_SEED_B_LSB: 0030</a>	

Table 2-16: Configuration Register Map (Cont'd)

Hex Address	Register name/link to Description	Notes
0x0034	<a href="#">CONFIGURATION_TX_TEST_PAT_SEED_B_MSB: 0034</a>	
0x0038	<a href="#">CONFIGURATION_1588_REG: 0038</a>	
0x0040	<a href="#">CONFIGURATION_TX_FLOW_CONTROL_REG1: 0040</a>	
0x0044	<a href="#">CONFIGURATION_TX_FLOW_CONTROL_REFRESH_REG1: 0044</a>	
0x0048	<a href="#">CONFIGURATION_TX_FLOW_CONTROL_REFRESH_REG2: 0048</a>	
0x004C	<a href="#">CONFIGURATION_TX_FLOW_CONTROL_REFRESH_REG3: 004C</a>	
0x0050	<a href="#">CONFIGURATION_TX_FLOW_CONTROL_REFRESH_REG4: 0050</a>	
0x0054	<a href="#">CONFIGURATION_TX_FLOW_CONTROL_REFRESH_REG5: 0054</a>	
0x0058	<a href="#">CONFIGURATION_TX_FLOW_CONTROL_QUANTA_REG1: 0058</a>	
0x005C	<a href="#">CONFIGURATION_TX_FLOW_CONTROL_QUANTA_REG2: 005C</a>	
0x0060	<a href="#">CONFIGURATION_TX_FLOW_CONTROL_QUANTA_REG3: 0060</a>	
0x0064	<a href="#">CONFIGURATION_TX_FLOW_CONTROL_QUANTA_REG4: 0064</a>	
0x0068	<a href="#">CONFIGURATION_TX_FLOW_CONTROL_QUANTA_REG5: 0068</a>	
0x006C	<a href="#">CONFIGURATION_TX_FLOW_CONTROL_PPP_ETYPE_OP_REG: 006C</a>	
0x0070	<a href="#">CONFIGURATION_TX_FLOW_CONTROL_GPP_ETYPE_OP_REG: 0070</a>	
0x0074	<a href="#">CONFIGURATION_TX_FLOW_CONTROL_GPP_DA_REG_LSB: 0074</a>	
0x0078	<a href="#">CONFIGURATION_TX_FLOW_CONTROL_GPP_DA_REG_MSB: 0078</a>	
0x007C	<a href="#">CONFIGURATION_TX_FLOW_CONTROL_GPP_SA_REG_LSB: 007C</a>	
0x0080	<a href="#">CONFIGURATION_TX_FLOW_CONTROL_GPP_SA_REG_MSB: 0080</a>	
0x0084	<a href="#">CONFIGURATION_TX_FLOW_CONTROL_PPP_DA_REG_LSB: 0084</a>	
0x0088	<a href="#">CONFIGURATION_TX_FLOW_CONTROL_PPP_DA_REG_MSB: 0088</a>	
0x008C	<a href="#">CONFIGURATION_TX_FLOW_CONTROL_PPP_SA_REG_LSB: 008C</a>	
0x0090	<a href="#">CONFIGURATION_TX_FLOW_CONTROL_PPP_SA_REG_MSB: 0090</a>	
0x0094	<a href="#">CONFIGURATION_RX_FLOW_CONTROL_REG1: 0094</a>	
0x0098	<a href="#">CONFIGURATION_RX_FLOW_CONTROL_REG2: 0098</a>	
0x009C	<a href="#">CONFIGURATION_RX_FLOW_CONTROL_PPP_ETYPE_OP_REG: 009C</a>	
0x00A0	<a href="#">CONFIGURATION_RX_FLOW_CONTROL_GPP_ETYPE_OP_REG: 00A0</a>	
0x00A4	<a href="#">CONFIGURATION_RX_FLOW_CONTROL_GCP_PCP_TYPE_REG: 00A4</a>	
0x00A8	<a href="#">CONFIGURATION_RX_FLOW_CONTROL_PCP_OP_REG: 00A8</a>	
0x00AC	<a href="#">CONFIGURATION_RX_FLOW_CONTROL_GCP_OP_REG: 00AC</a>	
0x00B0	<a href="#">CONFIGURATION_RX_FLOW_CONTROL_DA_REG1_LSB: 00B0</a>	
0x00B4	<a href="#">CONFIGURATION_RX_FLOW_CONTROL_DA_REG1_MSB: 00B4</a>	
0x00B8	<a href="#">CONFIGURATION_RX_FLOW_CONTROL_DA_REG2_LSB: 00B8</a>	
0x00BC	<a href="#">CONFIGURATION_RX_FLOW_CONTROL_DA_REG2_MSB: 00BC</a>	
0x00C0	<a href="#">CONFIGURATION_RX_FLOW_CONTROL_SA_REG1_LSB: 00C0</a>	

Table 2-16: Configuration Register Map (Cont'd)

Hex Address	Register name/link to Description	Notes
0x00C4	<a href="#">CONFIGURATION_RX_FLOW_CONTROL_SA_REG1_MSB: 00C4</a>	
0x00C8	<a href="#">CONFIGURATION_USXGMII_AN: 00C8</a>	
0x0184	<a href="#">USER_REG_0: 0184</a>	
0x0188	<a href="#">USER_REG_1: 0188</a>	
0x0194	<a href="#">CONFIGURATION_TX_PTP_LATENCY_ADJUST_REG: 0194</a>	
0x0198	<a href="#">CONFIGURATION_RX_PTP_LATENCY_ADJUST_REG: 0198</a>	

## Status Register Map

The status registers provide an indication of the health of the system. These registers are Read-Only and a read operation clears the register.

Status registers are cleared according to the following conditions.

- Applying `s_axi_aresetn` clears both TX and RX status registers
- When a particular status register is read (clear on read)
- Applying `rx_reset` clears the RX status registers only
- Applying `tx_reset` clears the TX status registers only

Table 2-17: Status Register Map

Hex Address	Register Name/Link to Description	Notes
0x0400	<a href="#">STAT_TX_STATUS_REG1: 0400</a>	
0x0404	<a href="#">STAT_RX_STATUS_REG1: 0404</a>	
0x0408	<a href="#">STAT_STATUS_REG1: 0408</a>	
0x040C	<a href="#">STAT_RX_BLOCK_LOCK_REG: 040C</a>	
0x0450	<a href="#">STAT_TX_FLOW_CONTROL_REG1: 0450</a>	
0x0454	<a href="#">STAT_RX_FLOW_CONTROL_REG1: 0454</a>	
0x0458	<a href="#">STAT_AN_STATUS_REG1: 0458</a>	
0x0494	<a href="#">STAT_RX_VALID_CTRL_CODE: 0494</a>	

## Statistics Counters

The statistics counters provide histograms of the classification of traffic and error counts. These counters can be read either by a 1 on `pm_tick` or by writing a 1 to `TICK_REG`, depending on the value of `MODE_REG[30]` (i.e. `tick_reg_mode_sel`). `pm_tick` will be used when `MODE_REG[30] = 0` and `TICK_REG` will be used when `MODE_REG[30] = 1` (1 = default).

The counters employ an internal accumulator. A write to the `TICK_REG` register causes the accumulated counts to be pushed to the readable `STAT*_MSB/LSB` registers and simultaneously clear the accumulators. The `STAT*_MSB/LSB` registers can then be read. In this way all values stored in the statistics counters represent a snap-shot over the same time interval.

The `STAT_CYCLE_COUNT_MSB/LSB` register contains a count of the number of RX core clock cycles between `TICK_REG` writes. This allows for easy time-interval based statistics.

Statistic counter registers are cleared according to the following conditions.

- Applying `s_axi_aresetn` clears both TX and RX statistics counter registers
- Applying PM Tick clears both TX and RX statistics counter registers
- Applying `rx_reset` clears the RX statistics counter registers only
- Applying `tx_reset` clears the TX statistics counter registers only

Table 2-18: Statistics Counters

Hex Address	Register Name/Link to Description	Notes
0x0500	<a href="#">STATUS_CYCLE_COUNT_LSB: 0500</a>	
0x0504	<a href="#">STATUS_CYCLE_COUNT_MSB: 0504</a>	
0x0648	<a href="#">STAT_RX_FRAMING_ERR_LSB: 0648</a>	
0x064C	<a href="#">STAT_RX_FRAMING_ERR_MSB: 064C</a>	
0x0660	<a href="#">STAT_RX_BAD_CODE_LSB: 0660</a>	
0x0664	<a href="#">STAT_RX_BAD_CODE_MSB: 0664</a>	
0x06A0	<a href="#">STAT_TX_FRAME_ERROR_LSB: 06A0</a>	
0x06A4	<a href="#">STAT_TX_FRAME_ERROR_MSB: 06A4</a>	
0x0700	<a href="#">STAT_TX_TOTAL_PACKETS_LSB: 0700</a>	
0x0704	<a href="#">STAT_TX_TOTAL_PACKETS_MSB: 0704</a>	
0x0708	<a href="#">STAT_TX_TOTAL_GOOD_PACKETS_LSB: 0708</a>	
0x070C	<a href="#">STAT_TX_TOTAL_GOOD_PACKETS_MSB: 070C</a>	
0x0710	<a href="#">STAT_TX_TOTAL_BYTES_LSB: 0710</a>	
0x0714	<a href="#">STAT_TX_TOTAL_BYTES_MSB: 0714</a>	
0x0718	<a href="#">STAT_TX_TOTAL_GOOD_BYTES_LSB: 0718</a>	

Table 2-18: Statistics Counters (Cont'd)

Hex Address	Register Name/Link to Description	Notes
0x071C	<a href="#">STAT_TX_TOTAL_GOOD_BYTES_MSB: 071C</a>	
0x0720	<a href="#">STAT_TX_PACKET_64_BYTES_LSB: 0720</a>	
0x0724	<a href="#">STAT_TX_PACKET_64_BYTES_MSB: 0724</a>	
0x0728	<a href="#">STAT_TX_PACKET_65_127_BYTES_LSB: 0728</a>	
0x072C	<a href="#">STAT_TX_PACKET_65_127_BYTES_MSB: 072C</a>	
0x0730	<a href="#">STAT_TX_PACKET_128_255_BYTES_LSB: 0730</a>	
0x0734	<a href="#">STAT_TX_PACKET_128_255_BYTES_MSB: 0734</a>	
0x0738	<a href="#">STAT_TX_PACKET_256_511_BYTES_LSB: 0738</a>	
0x073C	<a href="#">STAT_TX_PACKET_256_511_BYTES_MSB: 073C</a>	
0x0740	<a href="#">STAT_TX_PACKET_512_1023_BYTES_LSB: 0740</a>	
0x0744	<a href="#">STAT_TX_PACKET_512_1023_BYTES_MSB: 0744</a>	
0x0748	<a href="#">STAT_TX_PACKET_1024_1518_BYTES_LSB: 0748</a>	
0x074C	<a href="#">STAT_TX_PACKET_1024_1518_BYTES_MSB: 074C</a>	
0x0750	<a href="#">STAT_TX_PACKET_1519_1522_BYTES_LSB: 0750</a>	
0x0754	<a href="#">STAT_TX_PACKET_1519_1522_BYTES_MSB: 0754</a>	
0x0758	<a href="#">STAT_TX_PACKET_1523_1548_BYTES_LSB: 0758</a>	
0x075C	<a href="#">STAT_TX_PACKET_1523_1548_BYTES_MSB: 075C</a>	
0x0760	<a href="#">STAT_TX_PACKET_1549_2047_BYTES_LSB: 0760</a>	
0x0764	<a href="#">STAT_TX_PACKET_1549_2047_BYTES_MSB: 0764</a>	
0x0768	<a href="#">STAT_TX_PACKET_2048_4095_BYTES_LSB: 0768</a>	
0x076C	<a href="#">STAT_TX_PACKET_2048_4095_BYTES_MSB: 076C</a>	
0x0770	<a href="#">STAT_TX_PACKET_4096_8191_BYTES_LSB: 0770</a>	
0x0774	<a href="#">STAT_TX_PACKET_4096_8191_BYTES_MSB: 0774</a>	
0x0778	<a href="#">STAT_TX_PACKET_8192_9215_BYTES_LSB: 0778</a>	
0x077C	<a href="#">STAT_TX_PACKET_8192_9215_BYTES_MSB: 077C</a>	
0x0780	<a href="#">STAT_TX_PACKET_LARGE_LSB: 0780</a>	
0x0784	<a href="#">STAT_TX_PACKET_LARGE_MSB: 0784</a>	
0x0788	<a href="#">STAT_TX_PACKET_SMALL_LSB: 0788</a>	
0x078C	<a href="#">STAT_TX_PACKET_SMALL_MSB: 078C</a>	
0x07B8	<a href="#">STAT_TX_BAD_FCS_LSB: 07B8</a>	
0x07BC	<a href="#">STAT_TX_BAD_FCS_MSB: 07BC</a>	
0x07D0	<a href="#">STAT_TX_UNICAST_LSB: 07D0</a>	
0x07D4	<a href="#">STAT_TX_UNICAST_MSB: 07D4</a>	
0x07D8	<a href="#">STAT_TX_MULTICAST_LSB: 07D8</a>	
0x07DC	<a href="#">STAT_TX_MULTICAST_MSB: 07DC</a>	



Table 2-18: Statistics Counters (Cont'd)

Hex Address	Register Name/Link to Description	Notes
0x07E0	<a href="#">STAT_TX_BROADCAST_LSB: 07E0</a>	
0x07E4	<a href="#">STAT_TX_BROADCAST_MSB: 07E4</a>	
0x07E8	<a href="#">STAT_TX_VLAN_LSB: 07E8</a>	
0x07EC	<a href="#">STAT_TX_VLAN_MSB: 07EC</a>	
0x07F0	<a href="#">STAT_TX_PAUSE_LSB: 07F0</a>	
0x07F4	<a href="#">STAT_TX_PAUSE_MSB: 07F4</a>	
0x07F8	<a href="#">STAT_TX_USER_PAUSE_LSB: 07F8</a>	
0x07FC	<a href="#">STAT_TX_USER_PAUSE_MSB: 07FC</a>	
0x0808	<a href="#">STAT_RX_TOTAL_PACKETS_LSB: 0808</a>	
0x080C	<a href="#">STAT_RX_TOTAL_PACKETS_MSB: 080C</a>	
0x0810	<a href="#">STAT_RX_TOTAL_GOOD_PACKETS_LSB: 0810</a>	
0x0814	<a href="#">STAT_RX_TOTAL_GOOD_PACKETS_MSB: 0814</a>	
0x0818	<a href="#">STAT_RX_TOTAL_BYTES_LSB: 0818</a>	
0x081C	<a href="#">STAT_RX_TOTAL_BYTES_MSB: 081C</a>	
0x0820	<a href="#">STAT_RX_TOTAL_GOOD_BYTES_LSB: 0820</a>	
0x0824	<a href="#">STAT_RX_TOTAL_GOOD_BYTES_MSB: 0824</a>	
0x0828	<a href="#">STAT_RX_PACKET_64_BYTES_LSB: 0828</a>	
0x082C	<a href="#">STAT_RX_PACKET_64_BYTES_MSB: 082C</a>	
0x0830	<a href="#">STAT_RX_PACKET_65_127_BYTES_LSB: 0830</a>	
0x0834	<a href="#">STAT_RX_PACKET_65_127_BYTES_MSB: 0834</a>	
0x0838	<a href="#">STAT_RX_PACKET_128_255_BYTES_LSB: 0838</a>	
0x083C	<a href="#">STAT_RX_PACKET_128_255_BYTES_MSB: 083C</a>	
0x0840	<a href="#">STAT_RX_PACKET_256_511_BYTES_LSB: 0840</a>	
0x0844	<a href="#">STAT_RX_PACKET_256_511_BYTES_MSB: 0844</a>	
0x0848	<a href="#">STAT_RX_PACKET_512_1023_BYTES_LSB: 0848</a>	
0x084C	<a href="#">STAT_RX_PACKET_512_1023_BYTES_MSB: 084C</a>	
0x0850	<a href="#">STAT_RX_PACKET_1024_1518_BYTES_LSB: 0850</a>	
0x0854	<a href="#">STAT_RX_PACKET_1024_1518_BYTES_MSB: 0854</a>	
0x0858	<a href="#">STAT_RX_PACKET_1519_1522_BYTES_LSB: 0858</a>	
0x085C	<a href="#">STAT_RX_PACKET_1519_1522_BYTES_MSB: 085C</a>	
0x0860	<a href="#">STAT_RX_PACKET_1523_1548_BYTES_LSB: 0860</a>	
0x0864	<a href="#">STAT_RX_PACKET_1523_1548_BYTES_MSB: 0864</a>	
0x0868	<a href="#">STAT_RX_PACKET_1549_2047_BYTES_LSB: 0868</a>	
0x086C	<a href="#">STAT_RX_PACKET_1549_2047_BYTES_MSB: 086C</a>	
0x0870	<a href="#">STAT_RX_PACKET_2048_4095_BYTES_LSB: 0870</a>	

Table 2-18: Statistics Counters (Cont'd)

Hex Address	Register Name/Link to Description	Notes
0x0874	<a href="#">STAT_RX_PACKET_2048_4095_BYTES_MSB: 0874</a>	
0x0878	<a href="#">STAT_RX_PACKET_4096_8191_BYTES_LSB: 0878</a>	
0x087C	<a href="#">STAT_RX_PACKET_4096_8191_BYTES_MSB: 087C</a>	
0x0880	<a href="#">STAT_RX_PACKET_8192_9215_BYTES_LSB: 0880</a>	
0x0884	<a href="#">STAT_RX_PACKET_8192_9215_BYTES_MSB: 0884</a>	
0x0888	<a href="#">STAT_RX_PACKET_LARGE_LSB: 0888</a>	
0x088C	<a href="#">STAT_RX_PACKET_LARGE_MSB: 088C</a>	
0x0890	<a href="#">STAT_RX_PACKET_SMALL_LSB: 0890</a>	
0x0894	<a href="#">STAT_RX_PACKET_SMALL_MSB: 0894</a>	
0x0898	<a href="#">STAT_RX_UNDERSIZE_LSB: 0898</a>	
0x089C	<a href="#">STAT_RX_UNDERSIZE_MSB: 089C</a>	
0x08A0	<a href="#">STAT_RX_FRAGMENT_LSB: 08A0</a>	
0x08A4	<a href="#">STAT_RX_FRAGMENT_MSB: 08A4</a>	
0x08A8	<a href="#">STAT_RX_OVERSIZE_LSB: 08A8</a>	
0x08AC	<a href="#">STAT_RX_OVERSIZE_MSB: 08AC</a>	
0x08B0	<a href="#">STAT_RX_TOOLONG_LSB: 08B0</a>	
0x08B4	<a href="#">STAT_RX_TOOLONG_MSB: 08B4</a>	
0x08B8	<a href="#">STAT_RX_JABBER_LSB: 08B8</a>	
0x08BC	<a href="#">STAT_RX_JABBER_MSB: 08BC</a>	
0x08C0	<a href="#">STAT_RX_BAD_FCS_LSB: 08C0</a>	
0x08C4	<a href="#">STAT_RX_BAD_FCS_MSB: 08C4</a>	
0x08C8	<a href="#">STAT_RX_PACKET_BAD_FCS_LSB: 08C8</a>	
0x08CC	<a href="#">STAT_RX_PACKET_BAD_FCS_MSB: 08CC</a>	
0x08D0	<a href="#">STAT_RX_STOMPED_FCS_LSB: 08D0</a>	
0x08D4	<a href="#">STAT_RX_STOMPED_FCS_MSB: 08D4</a>	
0x08D8	<a href="#">STAT_RX_UNICAST_LSB: 08D8</a>	
0x08DC	<a href="#">STAT_RX_UNICAST_MSB: 08DC</a>	
0x08E0	<a href="#">STAT_RX_MULTICAST_LSB: 08E0</a>	
0x08E4	<a href="#">STAT_RX_MULTICAST_MSB: 08E4</a>	
0x08E8	<a href="#">STAT_RX_BROADCAST_LSB: 08E8</a>	
0x08EC	<a href="#">STAT_RX_BROADCAST_MSB: 08EC</a>	
0x08F0	<a href="#">STAT_RX_VLAN_LSB: 08F0</a>	
0x08F4	<a href="#">STAT_RX_VLAN_MSB: 08F4</a>	
0x08F8	<a href="#">STAT_RX_PAUSE_LSB: 08F8</a>	
0x08FC	<a href="#">STAT_RX_PAUSE_MSB: 08FC</a>	

Table 2-18: Statistics Counters (Cont'd)

Hex Address	Register Name/Link to Description	Notes
0x0900	<a href="#">STAT_RX_USER_PAUSE_LSB: 0900</a>	
0x0904	<a href="#">STAT_RX_USER_PAUSE_MSB: 0904</a>	
0x0908	<a href="#">STAT_RX_INRANGEERR_LSB: 0908</a>	
0x090C	<a href="#">STAT_RX_INRANGEERR_MSB: 090C</a>	
0x0910	<a href="#">STAT_RX_TRUNCATED_LSB: 0910</a>	
0x0914	<a href="#">STAT_RX_TRUNCATED_MSB: 0914</a>	
0x0918	<a href="#">STAT_RX_TEST_PATTERN_MISMATCH_LSB: 0918</a>	
0x091C	<a href="#">STAT_RX_TEST_PATTERN_MISMATCH_MSB: 091C</a>	

## Register Descriptions

This section contains descriptions of the configuration registers. In the cases where the features described in the bit fields are not present in the IP core, the bit field reverts to RESERVED.

### Configuration Registers

The following tables define the bit assignments for the configuration registers. Registers or bit fields within registers can be accessed for Read-Write (RW), Write-Only (WO), or Read-Only (RO). Default values shown are decimal values and take effect after a `s_axi_aresetn`.

A description of each signal is found in [Port Descriptions](#).

#### GT\_RESET\_REG: 0000

Table 2-19: GT\_RESET\_REG: 0000

Bits	Default	Type	Signal
0	0	RW	gt_reset This is a clear on write register.
1	0	RW	ctl_gt_rx_reset
2	0	RW	ctl_gt_tx_reset

#### RESET\_REG: 0004

Table 2-20: RESET\_REG: 0004

Bits	Default	Type	Signal
0	0	RW	rx_serdes_reset
29	0	RW	tx_serdes_reset

Table 2-20: RESET\_REG: 0004 (Cont'd)

Bits	Default	Type	Signal
30	0	RW	rx_reset
31	0	RW	tx_reset

### MODE\_REG: 0008

Table 2-21: MODE\_REG: 0008

Bits	Default	Type	Signal
30	1	RW	tick_reg_mode_sel
31	0	RW	ctl_local_loopback Sets GT in near-end PMA loopback

### CONFIGURATION\_TX\_REG1: 000C

Table 2-22: CONFIGURATION\_TX\_REG1: 000C

Bits	Default	Type	Signal
0	1	RW	ctl_tx_enable
1	1	RW	ctl_tx_fcs_ins_enable
2	0	RW	ctl_tx_ignore_fcs
3	0	RW	ctl_tx_send_lfi
4	0	RW	ctl_tx_send_rfi
5	0	RW	ctl_tx_send_idle
6	0	RW	ctl_tx_send_umii_lfi
7	0	RW	ctl_tx_send_umii_rfi
15	0	RW	ctl_tx_test_pattern_enable
16	0	RW	ctl_tx_test_pattern_select
17	0	RW	ctl_tx_data_pattern_select
18	0	RW	ctl_tx_custom_preamble_enable

### CONFIGURATION\_RX\_REG1: 0014

Table 2-23: CONFIGURATION\_RX\_REG1: 0014

Bits	Default	Type	Signal
0	1	RW	ctl_rx_enable
1	1	RW	ctl_rx_delete_fcs
2	0	RW	ctl_rx_ignore_fcs
3	0	RW	ctl_rx_process_lfi

Table 2-23: CONFIGURATION\_RX\_REG1: 0014 (Cont'd)

Bits	Default	Type	Signal
4	1	RW	ctl_rx_check_sfd
5	1	RW	ctl_rx_check_preamble
6	0	RW	ctl_rx_force_resync
8	0	RW	ctl_rx_test_pattern_enable
9	0	RW	ctl_rx_data_pattern_select
11	0	RW	ctl_rx_custom_preamble_enable

### CONFIGURATION\_RX\_MTU: 0018

Table 2-24: CONFIGURATION\_RX\_MTU: 0018

Bits	Default	Type	Signal
7:0	64	RW	ctl_rx_min_packet_len
30:16	9,600	RW	ctl_rx_max_packet_len

### TICK\_REG: 0020

Table 2-25: TICK\_REG: 0020

Bits	Default	Type	Signal
0	0	WO	tick_reg

### CONFIGURATION\_REVISION\_REG: 0024

Table 2-26: CONFIGURATION\_REVISION\_REG: 0024

Bits	Default	Type	Signal
7:0	1	RO	major_rev
15:8	1	RO	minor_rev
31:24	0	RO	patch_rev

### CONFIGURATION\_TX\_TEST\_PAT\_SEED\_A\_LSB: 0028

Table 2-27: CONFIGURATION\_TX\_TEST\_PAT\_SEED\_A\_LSB: 0028

Bits	Default	Type	Signal
31:0	0	RW	ctl_tx_test_pattern_seed_a[31:0]

**CONFIGURATION\_TX\_TEST\_PAT\_SEED\_A\_MSB: 002C**

Table 2-28: CONFIGURATION\_TX\_TEST\_PAT\_SEED\_A\_MSB: 002C

Bits	Default	Type	Signal
25:0	0	RW	ctl_tx_test_pattern_seed_a[57:32]

**CONFIGURATION\_TX\_TEST\_PAT\_SEED\_B\_LSB: 0030**

Table 2-29: CONFIGURATION\_TX\_TEST\_PAT\_SEED\_B\_LSB: 0030

Bits	Default	Type	Signal
31:0	0	RW	ctl_tx_test_pattern_seed_b[31:0]

**CONFIGURATION\_TX\_TEST\_PAT\_SEED\_B\_MSB: 0034**

Table 2-30: CONFIGURATION\_TX\_TEST\_PAT\_SEED\_B\_MSB: 0034

Bits	Default	Type	Signal
25:0	0	RW	ctl_tx_test_pattern_seed_b[57:32]

**CONFIGURATION\_1588\_REG: 0038**

Table 2-31: CONFIGURATION\_1588\_REG: 0038

Bits	Default	Type	Signal
0	0	RW	ctl_tx_ptp_1step_enable
2	0	RW	ctl_ptp_transpclk_mode

**CONFIGURATION\_TX\_FLOW\_CONTROL\_REG1: 0040**

Table 2-32: CONFIGURATION\_TX\_FLOW\_CONTROL\_REG1: 0040

Bits	Default	Type	Signal
8:0	0	RW	ctl_tx_pause_enable

**CONFIGURATION\_TX\_FLOW\_CONTROL\_REFRESH\_REG1: 0044**

Table 2-33: CONFIGURATION\_TX\_FLOW\_CONTROL\_REFRESH\_REG1: 0044

Bits	Default	Type	Signal
15:0	0	RW	ctl_tx_pause_refresh_timer0
31:16	0	RW	ctl_tx_pause_refresh_timer1

**CONFIGURATION\_TX\_FLOW\_CONTROL\_REFRESH\_REG2: 0048**

Table 2-34: CONFIGURATION\_TX\_FLOW\_CONTROL\_REFRESH\_REG2: 0048

Bits	Default	Type	Signal
15:0	0	RW	ctl_tx_pause_refresh_timer2
31:16	0	RW	ctl_tx_pause_refresh_timer3

**CONFIGURATION\_TX\_FLOW\_CONTROL\_REFRESH\_REG3: 004C**

Table 2-35: CONFIGURATION\_TX\_FLOW\_CONTROL\_REFRESH\_REG3: 004C

Bits	Default	Type	Signal
15:0	0	RW	ctl_tx_pause_refresh_timer4
31:16	0	RW	ctl_tx_pause_refresh_timer5

**CONFIGURATION\_TX\_FLOW\_CONTROL\_REFRESH\_REG4: 0050**

Table 2-36: CONFIGURATION\_TX\_FLOW\_CONTROL\_REFRESH\_REG4: 0050

Bits	Default	Type	Signal
15:0	0	RW	ctl_tx_pause_refresh_timer6
31:16	0	RW	ctl_tx_pause_refresh_timer7

**CONFIGURATION\_TX\_FLOW\_CONTROL\_REFRESH\_REG5: 0054**

Table 2-37: CONFIGURATION\_TX\_FLOW\_CONTROL\_REFRESH\_REG5: 0054

Bits	Default	Type	Signal
15:0	0	RW	ctl_tx_pause_refresh_timer8

**CONFIGURATION\_TX\_FLOW\_CONTROL\_QUANTA\_REG1: 0058**

Table 2-38: CONFIGURATION\_TX\_FLOW\_CONTROL\_QUANTA\_REG1: 0058

Bits	Default	Type	Signal
15:0	0	RW	ctl_tx_pause_quanta0
31:16	0	RW	ctl_tx_pause_quanta1

**CONFIGURATION\_TX\_FLOW\_CONTROL\_QUANTA\_REG2: 005C**

Table 2-39: CONFIGURATION\_TX\_FLOW\_CONTROL\_QUANTA\_REG2: 005C

Bits	Default	Type	Signal
15:0	0	RW	ctl_tx_pause_quanta2
31:16	0	RW	ctl_tx_pause_quanta3

**CONFIGURATION\_TX\_FLOW\_CONTROL\_QUANTA\_REG3: 0060**

Table 2-40: CONFIGURATION\_TX\_FLOW\_CONTROL\_QUANTA\_REG3: 0060

Bits	Default	Type	Signal
15:0	0	RW	ctl_tx_pause_quanta4
31:16	0	RW	ctl_tx_pause_quanta5

**CONFIGURATION\_TX\_FLOW\_CONTROL\_QUANTA\_REG4: 0064**

Table 2-41: CONFIGURATION\_TX\_FLOW\_CONTROL\_QUANTA\_REG4: 0064

Bits	Default	Type	Signal
15:0	0	RW	ctl_tx_pause_quanta6
31:16	0	RW	ctl_tx_pause_quanta7

**CONFIGURATION\_TX\_FLOW\_CONTROL\_QUANTA\_REG5: 0068**

Table 2-42: CONFIGURATION\_TX\_FLOW\_CONTROL\_QUANTA\_REG5: 0068

Bits	Default	Type	Signal
15:0	0	RW	ctl_tx_pause_quanta8

**CONFIGURATION\_TX\_FLOW\_CONTROL\_PPP\_ETYPE\_OP\_REG: 006C**

Table 2-43: CONFIGURATION\_TX\_FLOW\_CONTROL\_PPP\_ETYPE\_OP\_REG: 006C

Bits	Default	Type	Signal
15:0	34824	RW	ctl_tx_ethertype_ppp
31:16	257	RW	ctl_tx_opcode_ppp



**CONFIGURATION\_TX\_FLOW\_CONTROL\_GPP\_ETYPE\_OP\_REG: 0070**

Table 2-44: CONFIGURATION\_TX\_FLOW\_CONTROL\_GPP\_ETYPE\_OP\_REG: 0070

Bits	Default	Type	Signal
15:0	34824	RW	ctl_tx_ethertype_gpp
31:16	1	RW	ctl_tx_opcode_gpp

**CONFIGURATION\_TX\_FLOW\_CONTROL\_GPP\_DA\_REG\_LSB: 0074**

Table 2-45: CONFIGURATION\_TX\_FLOW\_CONTROL\_GPP\_DA\_REG\_LSB: 0074

Bits	Default	Type	Signal
31:0	0	RW	ctl_tx_da_gpp[31:0]

**CONFIGURATION\_TX\_FLOW\_CONTROL\_GPP\_DA\_REG\_MSB: 0078**

Table 2-46: CONFIGURATION\_TX\_FLOW\_CONTROL\_GPP\_DA\_REG\_MSB: 0078

Bits	Default	Type	Signal
15:0	0	RW	ctl_tx_da_gpp[47:32]

**CONFIGURATION\_TX\_FLOW\_CONTROL\_GPP\_SA\_REG\_LSB: 007C**

Table 2-47: CONFIGURATION\_TX\_FLOW\_CONTROL\_GPP\_SA\_REG\_LSB: 007C

Bits	Default	Type	Signal
31:0	0	RW	ctl_tx_sa_gpp[31:0]

**CONFIGURATION\_TX\_FLOW\_CONTROL\_GPP\_SA\_REG\_MSB: 0080**

Table 2-48: CONFIGURATION\_TX\_FLOW\_CONTROL\_GPP\_SA\_REG\_MSB: 0080

Bits	Default	Type	Signal
15:0	0	RW	ctl_tx_sa_gpp[47:32]

**CONFIGURATION\_TX\_FLOW\_CONTROL\_PPP\_DA\_REG\_LSB: 0084**

Table 2-49: CONFIGURATION\_TX\_FLOW\_CONTROL\_PPP\_DA\_REG\_LSB: 0084

Bits	Default	Type	Signal
31:0	0	RW	ctl_tx_da_ppp[31:0]

**CONFIGURATION\_TX\_FLOW\_CONTROL\_PPP\_DA\_REG\_MSB: 0088**

Table 2-50: CONFIGURATION\_TX\_FLOW\_CONTROL\_PPP\_DA\_REG\_MSB: 0088

Bits	Default	Type	Signal
15:0	0	RW	ctl_tx_da_ppp[47:32]

**CONFIGURATION\_TX\_FLOW\_CONTROL\_PPP\_SA\_REG\_LSB: 008C**

Table 2-51: CONFIGURATION\_TX\_FLOW\_CONTROL\_PPP\_SA\_REG\_LSB: 008C

Bits	Default	Type	Signal
31:0	0	RW	ctl_tx_sa_ppp[31:0]

**CONFIGURATION\_TX\_FLOW\_CONTROL\_PPP\_SA\_REG\_MSB: 0090**

Table 2-52: CONFIGURATION\_TX\_FLOW\_CONTROL\_PPP\_SA\_REG\_MSB: 0090

Bits	Default	Type	Signal
15:0	0	RW	ctl_tx_sa_ppp[47:32]

**CONFIGURATION\_RX\_FLOW\_CONTROL\_REG1: 0094**

Table 2-53: CONFIGURATION\_RX\_FLOW\_CONTROL\_REG1: 0094

Bits	Default	Type	Signal
8:0	0	RW	ctl_rx_pause_enable
9	0	RW	ctl_rx_forward_control
10	0	RW	ctl_rx_enable_gcp
11	0	RW	ctl_rx_enable_pcp
12	0	RW	ctl_rx_enable_gpp
13	0	RW	ctl_rx_enable_ppp
14	0	RW	ctl_rx_check_ack

**CONFIGURATION\_RX\_FLOW\_CONTROL\_REG2: 0098**

Table 2-54: CONFIGURATION\_RX\_FLOW\_CONTROL\_REG2: 0098

Bits	Default	Type	Signal
0	0	RW	ctl_rx_check_mcast_gcp
1	0	RW	ctl_rx_check_ucast_gcp
2	0	RW	ctl_rx_check_sa_gcp
3	0	RW	ctl_rx_check_etype_gcp
4	0	RW	ctl_rx_check_opcode_gcp

Table 2-54: CONFIGURATION\_RX\_FLOW\_CONTROL\_REG2: 0098 (Cont'd)

Bits	Default	Type	Signal
5	0	RW	ctl_rx_check_mcast_pcp
6	0	RW	ctl_rx_check_ucast_pcp
7	0	RW	ctl_rx_check_sa_pcp
8	0	RW	ctl_rx_check_etype_pcp
9	0	RW	ctl_rx_check_opcode_pcp
10	0	RW	ctl_rx_check_mcast_gpp
11	0	RW	ctl_rx_check_ucast_gpp
12	0	RW	ctl_rx_check_sa_gpp
13	0	RW	ctl_rx_check_etype_gpp
14	0	RW	ctl_rx_check_opcode_gpp
15	0	RW	ctl_rx_check_mcast_ppp
16	0	RW	ctl_rx_check_ucast_ppp
17	0	RW	ctl_rx_check_sa_ppp
18	0	RW	ctl_rx_check_etype_ppp
19	0	RW	ctl_rx_check_opcode_ppp

#### CONFIGURATION\_RX\_FLOW\_CONTROL\_PPP\_ETYPE\_OP\_REG: 009C

Table 2-55: CONFIGURATION\_RX\_FLOW\_CONTROL\_PPP\_ETYPE\_OP\_REG: 009C

Bits	Default	Type	Signal
15:0	34,824	RW	ctl_rx_etype_ppp
31:16	257	RW	ctl_rx_opcode_ppp

#### CONFIGURATION\_RX\_FLOW\_CONTROL\_GPP\_ETYPE\_OP\_REG: 00A0

Table 2-56: CONFIGURATION\_RX\_FLOW\_CONTROL\_GPP\_ETYPE\_OP\_REG: 00A0

Bits	Default	Type	Signal
15:0	34,824	RW	ctl_rx_etype_gpp
31:16	1	RW	ctl_rx_opcode_gpp

#### CONFIGURATION\_RX\_FLOW\_CONTROL\_GCP\_PCP\_TYPE\_REG: 00A4

Table 2-57: CONFIGURATION\_RX\_FLOW\_CONTROL\_GCP\_PCP\_TYPE\_REG: 00A4

Bits	Default	Type	Signal
15:0	34,824	RW	ctl_rx_etype_gcp
31:16	34,824	RW	ctl_rx_etype_pcp

**CONFIGURATION\_RX\_FLOW\_CONTROL\_PCP\_OP\_REG: 00A8**

Table 2-58: CONFIGURATION\_RX\_FLOW\_CONTROL\_PCP\_OP\_REG: 00A8

Bits	Default	Type	Signal
15:0	257	RW	ctl_rx_opcode_min_pcp
31:16	257	RW	ctl_rx_opcode_max_pcp

**CONFIGURATION\_RX\_FLOW\_CONTROL\_GCP\_OP\_REG: 00AC**

Table 2-59: CONFIGURATION\_RX\_FLOW\_CONTROL\_GCP\_OP\_REG: 00AC

Bits	Default	Type	Signal
15:0	1	RW	ctl_rx_opcode_min_gcp
31:16	6	RW	ctl_rx_opcode_max_gcp

**CONFIGURATION\_RX\_FLOW\_CONTROL\_DA\_REG1\_LSB: 00B0**

Table 2-60: CONFIGURATION\_RX\_FLOW\_CONTROL\_DA\_REG1\_LSB: 00B0

Bits	Default	Type	Signal
31:0	0	RW	ctl_rx_pause_da_ucast[31:0]

**CONFIGURATION\_RX\_FLOW\_CONTROL\_DA\_REG1\_MSB: 00B4**

Table 2-61: CONFIGURATION\_RX\_FLOW\_CONTROL\_DA\_REG1\_MSB: 00B4

Bits	Default	Type	Signal
15:0	0	RW	ctl_rx_pause_da_ucast[47:32]

**CONFIGURATION\_RX\_FLOW\_CONTROL\_DA\_REG2\_LSB: 00B8**

Table 2-62: CONFIGURATION\_RX\_FLOW\_CONTROL\_DA\_REG2\_LSB: 00B8

Bits	Default	Type	Signal
31:0	0	RW	ctl_rx_pause_da_mcast[31:0]

**CONFIGURATION\_RX\_FLOW\_CONTROL\_DA\_REG2\_MSB: 00BC**

Table 2-63: CONFIGURATION\_RX\_FLOW\_CONTROL\_DA\_REG2\_MSB: 00BC

Bits	Default	Type	Signal
15:0	0	RW	ctl_rx_pause_da_mcast[47:32]

**CONFIGURATION\_RX\_FLOW\_CONTROL\_SA\_REG1\_LSB: 00C0**

Table 2-64: CONFIGURATION\_RX\_FLOW\_CONTROL\_SA\_REG1\_LSB: 00C0

Bits	Default	Type	Signal
31:0	0	RW	ctl_rx_pause_sa[31:0]

**CONFIGURATION\_RX\_FLOW\_CONTROL\_SA\_REG1\_MSB: 00C4**

Table 2-65: CONFIGURATION\_RX\_FLOW\_CONTROL\_SA\_REG1\_MSB: 00C4

Bits	Default	Type	Signal
15:0	0	RW	ctl_rx_pause_sa[47:32]

**CONFIGURATION\_USXGMII\_AN: 00C8**

Table 2-66: CONFIGURATION\_USXGMII\_AN: 00C8

Bits	Default	Type	Signal
0	0	RW	ctl_umii_an_bypass
4:1	000	RW	ctl_umii_an_link_timer_config
5	0	RW	ctl_umii_an_mr_an_enable
6	0	RW	ctl_umii_an_mr_main_reset
7	0	RW	ctl_umii_an_mr_restart_an
10:8	011	RW	ctl_usxgmii_rate • 000: 10 Mb/s • 001: 100 Mb/s • 010: 1 Gb/s • 011: 10 Gb/s • 100: 2.5 Gb/s • 101: 5 Gb/s
15:11	0	RO	Reserved for future use
16	1	RW	USXGMII
22:17	0	RW	Reserved for future use
23	0	RW	EEE clock stop capability; Not supported
24	0	RW	EEE capability; Not supported.
27:25	011	RW	Speed; refer to table f N-base-T_usxgmii rev1.4
28	1	RW	Duplex Mode. 1 = Full Duplex, 0=Half Duplex
29	0	RW	Reserved for future use
30	0	RO	AN acknowledge
31	0	RW	Link Status

**USER\_REG\_0: 0184**

Table 2-67: USER\_REG\_0: 0184

Bits	Default	Type	Signal
31:0	0	RW	user_reg0

**USER\_REG\_1: 0188**

Table 2-68: USER\_REG\_1: 0188

Bits	Default	Type	Signal
31:0	0	RW	user_reg1

**CONFIGURATION\_TX\_PTP\_LATENCY\_ADJUST\_REG: 0194**

Table 2-69: CONFIGURATION\_TX\_PTP\_LATENCY\_ADJUST\_REG: 0194

Bits	Default	Type	Signal
15:0	0	RW	ctl_tx_ptp_latency_adjust

**CONFIGURATION\_RX\_PTP\_LATENCY\_ADJUST\_REG: 0198**

Table 2-70: CONFIGURATION\_RX\_PTP\_LATENCY\_ADJUST\_REG: 0198

Bits	Default	Type	Signal
15:0	0	RW	ctl_rx_ptp_latency_adjust

**Status Registers**

The tables in this section define the bit assignments for the status registers. Some bits are sticky, that is, latching their value High or Low once set. This is indicated by the type LH (Latched High) or LL (Latched Low).

A description of each signal is found in [Port Descriptions](#).

**STAT\_TX\_STATUS\_REG1: 0400**

Table 2-71: STAT\_TX\_STATUS\_REG1: 0400

Bits	Default	Type	Signal
0	0	RO LH	stat_tx_local_fault

**STAT\_RX\_STATUS\_REG1: 0404**

Table 2-72: STAT\_RX\_STATUS\_REG1: 0404

Bits	Default	Type	Signal
4	0	RO LH	stat_rx_hi_ber
5	0	RO LH	stat_rx_remote_fault
6	0	RO LH	stat_rx_local_fault
7	0	RO LH	stat_rx_internal_local_fault
8	0	RO LH	stat_rx_received_local_fault
9	0	RO LH	stat_rx_bad_preamble
10	0	RO LH	stat_rx_bad_sfd
11	0	RO LH	stat_rx_got_signal_os
12	0	RO LH	stat_rx_umii_local_fault
13	0	RO LH	stat_rx_umii_remote_fault

**STAT\_STATUS\_REG1: 0408**

Table 2-73: STAT\_STATUS\_REG1: 0408

Bits	Default	Type	Signal
4	0	RO LH	stat_tx_ptp_fifo_read_error
5	0	RO LH	stat_tx_ptp_fifo_write_error

**STAT\_RX\_BLOCK\_LOCK\_REG: 040C**

Table 2-74: STAT\_RX\_BLOCK\_LOCK\_REG: 040C

Bits	Default	Type	Signal
0	1	RO LL	stat_rx_block_lock

**STAT\_TX\_FLOW\_CONTROL\_REG1: 0450**

Table 2-75: STAT\_TX\_FLOW\_CONTROL\_REG1: 0450

Bits	Default	Type	Signal
8:0	0	RO LH	stat_tx_pause_valid

**STAT\_RX\_FLOW\_CONTROL\_REG1: 0454**

Table 2-76: STAT\_RX\_FLOW\_CONTROL\_REG1: 0454

Bits	Default	Type	Signal
8:0	0	RO LH	stat_rx_pause_req
17:9	0	RO LH	stat_rx_pause_valid

**STAT\_AN\_STATUS\_REG1: 0458**

Table 2-77: STAT\_AN\_STATUS\_REG1: 0458

Bits	Default	Type	Signal
15:0	0	RO	stat_umii_an_mr_lp_adv_ability
16	0	RO	stat_umii_an_mr_an_complete
17	0	RO	stat_umii_an_mr_np_able

**Notes:**

1. AN Status register is not clear on read.

**STAT\_RX\_VALID\_CTRL\_CODE: 0494**

Table 2-78: STAT\_RX\_VALID\_CTRL\_CODE: 0494

Bits	Default	Type	Signal
0	0	RO LH	stat_rx_valid_ctrl_code



## Statistics Counters

The following tables define the bit assignments for the statistics counters. Counters are 48 bits and require two 32-bit address spaces containing the MSB and LSB as indicated. The default value of all counters is 0. Counters are cleared when read by `tick_reg` (or `pm_tick` if so selected) but the register containing the count retains its value. Each counter saturates at FFFFFFFF (hex).

A description of each signal is found in [Port Descriptions](#).

### STATUS\_CYCLE\_COUNT\_LSB: 0500

Table 2-79: STATUS\_CYCLE\_COUNT\_LSB: 0500

Bits	Default	Type	Signal
31:0	0	RO HIST	stat_cycle_count[31:0]

### STATUS\_CYCLE\_COUNT\_MSB: 0504

Table 2-80: STATUS\_CYCLE\_COUNT\_MSB: 0504

Bits	Default	Type	Signal
15:0	0	RO HIST	stat_cycle_count[47:32]

### STAT\_RX\_FRAMING\_ERR\_LSB: 0648

Table 2-81: STAT\_RX\_FRAMING\_ERR\_LSB: 0648

Bits	Default	Type	Signal
31:0	0	HIST	stat_rx_framing_err_count[31:0]

### STAT\_RX\_FRAMING\_ERR\_MSB: 064C

Table 2-82: STAT\_RX\_FRAMING\_ERR\_MSB: 064C

Bits	Default	Type	Signal
15:0	0	HIST	stat_rx_framing_err_count[48-1:32]

### STAT\_RX\_BAD\_CODE\_LSB: 0660

Table 2-83: STAT\_RX\_BAD\_CODE\_LSB: 0660

Bits	Default	Type	Signal
31:0	0	HIST	stat_rx_bad_code_count[31:0]

**STAT\_RX\_BAD\_CODE\_MSB: 0664**

Table 2-84: STAT\_RX\_BAD\_CODE\_MSB: 0664

Bits	Default	Type	Signal
15:0	0	HIST	stat_rx_bad_code_count[47:32]

**STAT\_TX\_FRAME\_ERROR\_LSB: 06A0**

Table 2-85: STAT\_TX\_FRAME\_ERROR\_LSB: 06A0

Bits	Default	Type	Signal
31:0	0	HIST	stat_tx_frame_error_count[31:0]

**STAT\_TX\_FRAME\_ERROR\_MSB: 06A4**

Table 2-86: STAT\_TX\_FRAME\_ERROR\_MSB: 06A4

Bits	Default	Type	Signal
15:0	0	HIST	stat_tx_frame_error_count[47:32]

**STAT\_TX\_TOTAL\_PACKETS\_LSB: 0700**

Table 2-87: STAT\_TX\_TOTAL\_PACKETS\_LSB: 0700

Bits	Default	Type	Signal
31:0	0	HIST	stat_tx_total_packets_count[31:0]

**STAT\_TX\_TOTAL\_PACKETS\_MSB: 0704**

Table 2-88: STAT\_TX\_TOTAL\_PACKETS\_MSB: 0704

Bits	Default	Type	Signal
15:0	0	HIST	stat_tx_total_packets_count[47:32]

**STAT\_TX\_TOTAL\_GOOD\_PACKETS\_LSB: 0708**

Table 2-89: STAT\_TX\_TOTAL\_GOOD\_PACKETS\_LSB: 0708

Bits	Default	Type	Signal
31:0	0	HIST	stat_tx_total_good_packets_count[31:0]

**STAT\_TX\_TOTAL\_GOOD\_PACKETS\_MSB: 070C**

Table 2-90: STAT\_TX\_TOTAL\_GOOD\_PACKETS\_MSB: 070C

Bits	Default	Type	Signal
15:0	0	HIST	stat_tx_total_good_packets_count[47:32]

**STAT\_TX\_TOTAL\_BYTES\_LSB: 0710**

Table 2-91: STAT\_TX\_TOTAL\_BYTES\_LSB: 0710

Bits	Default	Type	Signal
31:0	0	HIST	stat_tx_total_bytes_count[31:0]

**STAT\_TX\_TOTAL\_BYTES\_MSB: 0714**

Table 2-92: STAT\_TX\_TOTAL\_BYTES\_MSB: 0714

Bits	Default	Type	Signal
15:0	0	HIST	stat_tx_total_bytes_count[47:32]

**STAT\_TX\_TOTAL\_GOOD\_BYTES\_LSB: 0718**

Table 2-93: STAT\_TX\_TOTAL\_GOOD\_BYTES\_LSB: 0718

Bits	Default	Type	Signal
31:0	0	HIST	stat_tx_total_good_bytes_count[31:0]

**STAT\_TX\_TOTAL\_GOOD\_BYTES\_MSB: 071C**

Table 2-94: STAT\_TX\_TOTAL\_GOOD\_BYTES\_MSB: 071C

Bits	Default	Type	Signal
15:0	0	HIST	stat_tx_total_good_bytes_count[47:32]

**STAT\_TX\_PACKET\_64\_BYTES\_LSB: 0720**

Table 2-95: STAT\_TX\_PACKET\_64\_BYTES\_LSB: 0720

Bits	Default	Type	Signal
31:0	0	HIST	stat_tx_packet_64_bytes_count[31:0]

**STAT\_TX\_PACKET\_64\_BYTES\_MSB: 0724**

Table 2-96: STAT\_TX\_PACKET\_64\_BYTES\_MSB: 0724

Bits	Default	Type	Signal
15:0	0	HIST	stat_tx_packet_64_bytes_count[47:32]

**STAT\_TX\_PACKET\_65\_127\_BYTES\_LSB: 0728**

Table 2-97: STAT\_TX\_PACKET\_65\_127\_BYTES\_LSB: 0728

Bits	Default	Type	Signal
31:0	0	HIST	stat_tx_packet_65_127_bytes_count[31:0]

**STAT\_TX\_PACKET\_65\_127\_BYTES\_MSB: 072C**

Table 2-98: STAT\_TX\_PACKET\_65\_127\_BYTES\_MSB: 072C

Bits	Default	Type	Signal
15:0	0	HIST	stat_tx_packet_65_127_bytes_count[47:32]

**STAT\_TX\_PACKET\_128\_255\_BYTES\_LSB: 0730**

Table 2-99: STAT\_TX\_PACKET\_128\_255\_BYTES\_LSB: 0730

Bits	Default	Type	Signal
31:0	0	HIST	stat_tx_packet_128_255_bytes_count[31:0]

**STAT\_TX\_PACKET\_128\_255\_BYTES\_MSB: 0734**

Table 2-100: STAT\_TX\_PACKET\_128\_255\_BYTES\_MSB: 0734

Bits	Default	Type	Signal
15:0	0	HIST	stat_tx_packet_128_255_bytes_count[47:32]

**STAT\_TX\_PACKET\_256\_511\_BYTES\_LSB: 0738**

Table 2-101: STAT\_TX\_PACKET\_256\_511\_BYTES\_LSB: 0738

Bits	Default	Type	Signal
31:0	0	HIST	stat_tx_packet_256_511_bytes_count[31:0]

**STAT\_TX\_PACKET\_256\_511\_BYTES\_MSB: 073C**

Table 2-102: STAT\_TX\_PACKET\_256\_511\_BYTES\_MSB: 073C

Bits	Default	Type	Signal
15:0	0	HIST	stat_tx_packet_256_511_bytes_count[47:32]

**STAT\_TX\_PACKET\_512\_1023\_BYTES\_LSB: 0740**

Table 2-103: STAT\_TX\_PACKET\_512\_1023\_BYTES\_LSB: 0740

Bits	Default	Type	Signal
31:0	0	HIST	stat_tx_packet_512_1023_bytes_count[31:0]

**STAT\_TX\_PACKET\_512\_1023\_BYTES\_MSB: 0744**

Table 2-104: STAT\_TX\_PACKET\_512\_1023\_BYTES\_MSB: 0744

Bits	Default	Type	Signal
15:0	0	HIST	stat_tx_packet_512_1023_bytes_count[47:32]

**STAT\_TX\_PACKET\_1024\_1518\_BYTES\_LSB: 0748**

Table 2-105: STAT\_TX\_PACKET\_1024\_1518\_BYTES\_LSB: 0748

Bits	Default	Type	Signal
31:0	0	HIST	stat_tx_packet_1024_1518_bytes_count[31:0]

**STAT\_TX\_PACKET\_1024\_1518\_BYTES\_MSB: 074C**

Table 2-106: STAT\_TX\_PACKET\_1024\_1518\_BYTES\_MSB: 074C

Bits	Default	Type	Signal
15:0	0	HIST	stat_tx_packet_1024_1518_bytes_count[47:32]

**STAT\_TX\_PACKET\_1519\_1522\_BYTES\_LSB: 0750**

Table 2-107: STAT\_TX\_PACKET\_1519\_1522\_BYTES\_LSB: 0750

Bits	Default	Type	Signal
31:0	0	HIST	stat_tx_packet_1519_1522_bytes_count[31:0]

**STAT\_TX\_PACKET\_1519\_1522\_BYTES\_MSB: 0754**

Table 2-108: STAT\_TX\_PACKET\_1519\_1522\_BYTES\_MSB: 0754

Bits	Default	Type	Signal
15:0	0	HIST	stat_tx_packet_1519_1522_bytes_count[47:32]

**STAT\_TX\_PACKET\_1523\_1548\_BYTES\_LSB: 0758**

Table 2-109: STAT\_TX\_PACKET\_1523\_1548\_BYTES\_LSB: 0758

Bits	Default	Type	Signal
31:0	0	HIST	stat_tx_packet_1523_1548_bytes_count[31:0]

**STAT\_TX\_PACKET\_1523\_1548\_BYTES\_MSB: 075C**

Table 2-110: STAT\_TX\_PACKET\_1523\_1548\_BYTES\_MSB: 075C

Bits	Default	Type	Signal
15:0	0	HIST	stat_tx_packet_1523_1548_bytes_count[47:32]

**STAT\_TX\_PACKET\_1549\_2047\_BYTES\_LSB: 0760**

Table 2-111: STAT\_TX\_PACKET\_1549\_2047\_BYTES\_LSB: 0760

Bits	Default	Type	Signal
31:0	0	HIST	stat_tx_packet_1549_2047_bytes_count[31:0]

**STAT\_TX\_PACKET\_1549\_2047\_BYTES\_MSB: 0764**

Table 2-112: STAT\_TX\_PACKET\_1549\_2047\_BYTES\_MSB: 0764

Bits	Default	Type	Signal
15:0	0	HIST	stat_tx_packet_1549_2047_bytes_count[47:32]

**STAT\_TX\_PACKET\_2048\_4095\_BYTES\_LSB: 0768**

Table 2-113: STAT\_TX\_PACKET\_2048\_4095\_BYTES\_LSB: 0768

Bits	Default	Type	Signal
31:0	0	HIST	stat_tx_packet_2048_4095_bytes_count[31:0]

**STAT\_TX\_PACKET\_2048\_4095\_BYTES\_MSB: 076C**

Table 2-114: STAT\_TX\_PACKET\_2048\_4095\_BYTES\_MSB: 076C

Bits	Default	Type	Signal
15:0	0	HIST	stat_tx_packet_2048_4095_bytes_count[47:32]

**STAT\_TX\_PACKET\_4096\_8191\_BYTES\_LSB: 0770**

Table 2-115: STAT\_TX\_PACKET\_4096\_8191\_BYTES\_LSB: 0770

Bits	Default	Type	Signal
31:0	0	HIST	stat_tx_packet_4096_8191_bytes_count[31:0]

**STAT\_TX\_PACKET\_4096\_8191\_BYTES\_MSB: 0774**

Table 2-116: STAT\_TX\_PACKET\_4096\_8191\_BYTES\_MSB: 0774

Bits	Default	Type	Signal
15:0	0	HIST	stat_tx_packet_4096_8191_bytes_count[47:32]

**STAT\_TX\_PACKET\_8192\_9215\_BYTES\_LSB: 0778**

Table 2-117: STAT\_TX\_PACKET\_8192\_9215\_BYTES\_LSB: 0778

Bits	Default	Type	Signal
31:0	0	HIST	stat_tx_packet_8192_9215_bytes_count[31:0]

**STAT\_TX\_PACKET\_8192\_9215\_BYTES\_MSB: 077C**

Table 2-118: STAT\_TX\_PACKET\_8192\_9215\_BYTES\_MSB: 077C

Bits	Default	Type	Signal
15:0	0	HIST	stat_tx_packet_8192_9215_bytes_count[47:32]

**STAT\_TX\_PACKET\_LARGE\_LSB: 0780**

Table 2-119: STAT\_TX\_PACKET\_LARGE\_LSB: 0780

Bits	Default	Type	Signal
31:0	0	HIST	stat_tx_packet_large_count[31:0]

**STAT\_TX\_PACKET\_LARGE\_MSB: 0784**

Table 2-120: STAT\_TX\_PACKET\_LARGE\_MSB: 0784

Bits	Default	Type	Signal
15:0	0	HIST	stat_tx_packet_large_count[47:32]

**STAT\_TX\_PACKET\_SMALL\_LSB: 0788**

Table 2-121: STAT\_TX\_PACKET\_SMALL\_LSB: 0788

Bits	Default	Type	Signal
31:0	0	HIST	stat_tx_packet_small_count[31:0]

**STAT\_TX\_PACKET\_SMALL\_MSB: 078C**

Table 2-122: STAT\_TX\_PACKET\_SMALL\_MSB: 078C

Bits	Default	Type	Signal
15:0	0	HIST	stat_tx_packet_small_count[47:32]

**STAT\_TX\_BAD\_FCS\_LSB: 07B8**

Table 2-123: STAT\_TX\_BAD\_FCS\_LSB: 07B8

Bits	Default	Type	Signal
31:0	0	HIST	stat_tx_bad_fcs_count[31:0]

**STAT\_TX\_BAD\_FCS\_MSB: 07BC**

Table 2-124: STAT\_TX\_BAD\_FCS\_MSB: 07BC

Bits	Default	Type	Signal
15:0	0	HIST	stat_tx_bad_fcs_count[47:32]

**STAT\_TX\_UNICAST\_LSB: 07D0**

Table 2-125: STAT\_TX\_UNICAST\_LSB: 07D0

Bits	Default	Type	Signal
31:0	0	HIST	stat_tx_unicast_count[31:0]



**STAT\_TX\_UNICAST\_MSB: 07D4**

Table 2-126: STAT\_TX\_UNICAST\_MSB: 07D4

Bits	Default	Type	Signal
15:0	0	HIST	stat_tx_unicast_count[47:32]

**STAT\_TX\_MULTICAST\_LSB: 07D8**

Table 2-127: STAT\_TX\_MULTICAST\_LSB: 07D8

Bits	Default	Type	Signal
31:0	0	HIST	stat_tx_multicast_count[31:0]

**STAT\_TX\_MULTICAST\_MSB: 07DC**

Table 2-128: STAT\_TX\_MULTICAST\_MSB: 07DC

Bits	Default	Type	Signal
15:0	0	HIST	stat_tx_multicast_count[47:32]

**STAT\_TX\_BROADCAST\_LSB: 07E0**

Table 2-129: STAT\_TX\_BROADCAST\_LSB: 07E0

Bits	Default	Type	Signal
31:0	0	HIST	stat_tx_broadcast_count[31:0]

**STAT\_TX\_BROADCAST\_MSB: 07E4**

Table 2-130: STAT\_TX\_BROADCAST\_MSB: 07E4

Bits	Default	Type	Signal
15:0	0	HIST	stat_tx_broadcast_count[47:32]

**STAT\_TX\_VLAN\_LSB: 07E8**

Table 2-131: STAT\_TX\_VLAN\_LSB: 07E8

Bits	Default	Type	Signal
31:0	0	HIST	stat_tx_vlan_count[31:0]

**STAT\_TX\_VLAN\_MSB: 07EC**

Table 2-132: STAT\_TX\_VLAN\_MSB: 07EC

Bits	Default	Type	Signal
15:0	0	HIST	stat_tx_vlan_count[47:32]

**STAT\_TX\_PAUSE\_LSB: 07F0**

Table 2-133: STAT\_TX\_PAUSE\_LSB: 07F0

Bits	Default	Type	Signal
31:0	0	HIST	stat_tx_pause_count[31:0]

**STAT\_TX\_PAUSE\_MSB: 07F4**

Table 2-134: STAT\_TX\_PAUSE\_MSB: 07F4

Bits	Default	Type	Signal
15:0	0	HIST	stat_tx_pause_count[47:32]

**STAT\_TX\_USER\_PAUSE\_LSB: 07F8**

Table 2-135: STAT\_TX\_USER\_PAUSE\_LSB: 07F8

Bits	Default	Type	Signal
31:0	0	HIST	stat_tx_user_pause_count[31:0]

**STAT\_TX\_USER\_PAUSE\_MSB: 07FC**

Table 2-136: STAT\_TX\_USER\_PAUSE\_MSB: 07FC

Bits	Default	Type	Signal
15:0	0	HIST	stat_tx_user_pause_count[47:32]

**STAT\_RX\_TOTAL\_PACKETS\_LSB: 0808**

Table 2-137: STAT\_RX\_TOTAL\_PACKETS\_LSB: 0808

Bits	Default	Type	Signal
31:0	0	HIST	stat_rx_total_packets_count[31:0]

**STAT\_RX\_TOTAL\_PACKETS\_MSB: 080C**

Table 2-138: STAT\_RX\_TOTAL\_PACKETS\_MSB: 080C

Bits	Default	Type	Signal
15:0	0	HIST	stat_rx_total_packets_count[47:32]

**STAT\_RX\_TOTAL\_GOOD\_PACKETS\_LSB: 0810**

Table 2-139: STAT\_RX\_TOTAL\_GOOD\_PACKETS\_LSB: 0810

Bits	Default	Type	Signal
31:0	0	HIST	stat_rx_total_good_packets_count[31:0]

**STAT\_RX\_TOTAL\_GOOD\_PACKETS\_MSB: 0814**

Table 2-140: STAT\_RX\_TOTAL\_GOOD\_PACKETS\_MSB: 0814

Bits	Default	Type	Signal
15:0	0	HIST	stat_rx_total_good_packets_count[47:32]

**STAT\_RX\_TOTAL\_BYTES\_LSB: 0818**

Table 2-141: STAT\_RX\_TOTAL\_BYTES\_LSB: 0818

Bits	Default	Type	Signal
31:0	0	HIST	stat_rx_total_bytes_count[31:0]

**STAT\_RX\_TOTAL\_BYTES\_MSB: 081C**

Table 2-142: STAT\_RX\_TOTAL\_BYTES\_MSB: 081C

Bits	Default	Type	Signal
15:0	0	HIST	stat_rx_total_bytes_count[47:32]

**STAT\_RX\_TOTAL\_GOOD\_BYTES\_LSB: 0820**

Table 2-143: STAT\_RX\_TOTAL\_GOOD\_BYTES\_LSB: 0820

Bits	Default	Type	Signal
31:0	0	HIST	stat_rx_total_good_bytes_count[31:0]

**STAT\_RX\_TOTAL\_GOOD\_BYTES\_MSB: 0824**

Table 2-144: STAT\_RX\_TOTAL\_GOOD\_BYTES\_MSB: 0824

Bits	Default	Type	Signal
15:0	0	HIST	stat_rx_total_good_bytes_count[47:32]

**STAT\_RX\_PACKET\_64\_BYTES\_LSB: 0828**

Table 2-145: STAT\_RX\_PACKET\_64\_BYTES\_LSB: 0828

Bits	Default	Type	Signal
31:0	0	HIST	stat_rx_packet_64_bytes_count[31:0]

**STAT\_RX\_PACKET\_64\_BYTES\_MSB: 082C**

Table 2-146: STAT\_RX\_PACKET\_64\_BYTES\_MSB: 082C

Bits	Default	Type	Signal
15:0	0	HIST	stat_rx_packet_64_bytes_count[47:32]

**STAT\_RX\_PACKET\_65\_127\_BYTES\_LSB: 0830**

Table 2-147: STAT\_RX\_PACKET\_65\_127\_BYTES\_LSB: 0830

Bits	Default	Type	Signal
31:0	0	HIST	stat_rx_packet_65_127_bytes_count[31:0]

**STAT\_RX\_PACKET\_65\_127\_BYTES\_MSB: 0834**

Table 2-148: STAT\_RX\_PACKET\_65\_127\_BYTES\_MSB: 0834

Bits	Default	Type	Signal
15:0	0	HIST	stat_rx_packet_65_127_bytes_count[47:32]

**STAT\_RX\_PACKET\_128\_255\_BYTES\_LSB: 0838**

Table 2-149: STAT\_RX\_PACKET\_128\_255\_BYTES\_LSB: 0838

Bits	Default	Type	Signal
31:0	0	HIST	stat_rx_packet_128_255_bytes_count[31:0]

**STAT\_RX\_PACKET\_128\_255\_BYTES\_MSB: 083C**

Table 2-150: STAT\_RX\_PACKET\_128\_255\_BYTES\_MSB: 083C

Bits	Default	Type	Signal
15:0	0	HIST	stat_rx_packet_128_255_bytes_count[47:32]

**STAT\_RX\_PACKET\_256\_511\_BYTES\_LSB: 0840**

Table 2-151: STAT\_RX\_PACKET\_256\_511\_BYTES\_LSB: 0840

Bits	Default	Type	Signal
31:0	0	HIST	stat_rx_packet_256_511_bytes_count[31:0]

**STAT\_RX\_PACKET\_256\_511\_BYTES\_MSB: 0844**

Table 2-152: STAT\_RX\_PACKET\_256\_511\_BYTES\_MSB: 0844

Bits	Default	Type	Signal
15:0	0	HIST	stat_rx_packet_256_511_bytes_count[47:32]

**STAT\_RX\_PACKET\_512\_1023\_BYTES\_LSB: 0848**

Table 2-153: STAT\_RX\_PACKET\_512\_1023\_BYTES\_LSB: 0848

Bits	Default	Type	Signal
31:0	0	HIST	stat_rx_packet_512_1023_bytes_count[31:0]

**STAT\_RX\_PACKET\_512\_1023\_BYTES\_MSB: 084C**

Table 2-154: STAT\_RX\_PACKET\_512\_1023\_BYTES\_MSB: 084C

Bits	Default	Type	Signal
15:0	0	HIST	stat_rx_packet_512_1023_bytes_count[47:32]

**STAT\_RX\_PACKET\_1024\_1518\_BYTES\_LSB: 0850**

Table 2-155: STAT\_RX\_PACKET\_1024\_1518\_BYTES\_LSB: 0850

Bits	Default	Type	Signal
31:0	0	HIST	stat_rx_packet_1024_1518_bytes_count[31:0]

**STAT\_RX\_PACKET\_1024\_1518\_BYTES\_MSB: 0854**

Table 2-156: STAT\_RX\_PACKET\_1024\_1518\_BYTES\_MSB: 0854

Bits	Default	Type	Signal
15:0	0	HIST	stat_rx_packet_1024_1518_bytes_count[47:32]

**STAT\_RX\_PACKET\_1519\_1522\_BYTES\_LSB: 0858**

Table 2-157: STAT\_RX\_PACKET\_1519\_1522\_BYTES\_LSB: 0858

Bits	Default	Type	Signal
31:0	0	HIST	stat_rx_packet_1519_1522_bytes_count[31:0]

**STAT\_RX\_PACKET\_1519\_1522\_BYTES\_MSB: 085C**

Table 2-158: STAT\_RX\_PACKET\_1519\_1522\_BYTES\_MSB: 085C

Bits	Default	Type	Signal
15:0	0	HIST	stat_rx_packet_1519_1522_bytes_count[47:32]

**STAT\_RX\_PACKET\_1523\_1548\_BYTES\_LSB: 0860**

Table 2-159: STAT\_RX\_PACKET\_1523\_1548\_BYTES\_LSB: 0860

Bits	Default	Type	Signal
31:0	0	HIST	stat_rx_packet_1523_1548_bytes_count[31:0]

**STAT\_RX\_PACKET\_1523\_1548\_BYTES\_MSB: 0864**

Table 2-160: STAT\_RX\_PACKET\_1523\_1548\_BYTES\_MSB: 0864

Bits	Default	Type	Signal
15:0	0	HIST	stat_rx_packet_1523_1548_bytes_count[47:32]

**STAT\_RX\_PACKET\_1549\_2047\_BYTES\_LSB: 0868**

Table 2-161: STAT\_RX\_PACKET\_1549\_2047\_BYTES\_LSB: 0868

Bits	Default	Type	Signal
31:0	0	HIST	stat_rx_packet_1549_2047_bytes_count[31:0]

**STAT\_RX\_PACKET\_1549\_2047\_BYTES\_MSB: 086C**

Table 2-162: STAT\_RX\_PACKET\_1549\_2047\_BYTES\_MSB: 086C

Bits	Default	Type	Signal
15:0	0	HIST	stat_rx_packet_1549_2047_bytes_count[47:32]

**STAT\_RX\_PACKET\_2048\_4095\_BYTES\_LSB: 0870**

Table 2-163: STAT\_RX\_PACKET\_2048\_4095\_BYTES\_LSB: 0870

Bits	Default	Type	Signal
31:0	0	HIST	stat_rx_packet_2048_4095_bytes_count[31:0]

**STAT\_RX\_PACKET\_2048\_4095\_BYTES\_MSB: 0874**

Table 2-164: STAT\_RX\_PACKET\_2048\_4095\_BYTES\_MSB: 0874

Bits	Default	Type	Signal
15:0	0	HIST	stat_rx_packet_2048_4095_bytes_count[47:32]

**STAT\_RX\_PACKET\_4096\_8191\_BYTES\_LSB: 0878**

Table 2-165: STAT\_RX\_PACKET\_4096\_8191\_BYTES\_LSB: 0878

Bits	Default	Type	Signal
31:0	0	HIST	stat_rx_packet_4096_8191_bytes_count[31:0]

**STAT\_RX\_PACKET\_4096\_8191\_BYTES\_MSB: 087C**

Table 2-166: STAT\_RX\_PACKET\_4096\_8191\_BYTES\_MSB: 087C

Bits	Default	Type	Signal
15:0	0	HIST	stat_rx_packet_4096_8191_bytes_count[47:32]

**STAT\_RX\_PACKET\_8192\_9215\_BYTES\_LSB: 0880**

Table 2-167: STAT\_RX\_PACKET\_8192\_9215\_BYTES\_LSB: 0880

Bits	Default	Type	Signal
31:0	0	HIST	stat_rx_packet_8192_9215_bytes_count[31:0]

**STAT\_RX\_PACKET\_8192\_9215\_BYTES\_MSB: 0884**

Table 2-168: STAT\_RX\_PACKET\_8192\_9215\_BYTES\_MSB: 0884

Bits	Default	Type	Signal
15:0	0	HIST	stat_rx_packet_8192_9215_bytes_count[47:32]

**STAT\_RX\_PACKET\_LARGE\_LSB: 0888**

Table 2-169: STAT\_RX\_PACKET\_LARGE\_LSB: 0888

Bits	Default	Type	Signal
31:0	0	HIST	stat_rx_packet_large_count[31:0]

**STAT\_RX\_PACKET\_LARGE\_MSB: 088C**

Table 2-170: STAT\_RX\_PACKET\_LARGE\_MSB: 088C

Bits	Default	Type	Signal
15:0	0	HIST	stat_rx_packet_large_count[47:32]

**STAT\_RX\_PACKET\_SMALL\_LSB: 0890**

Table 2-171: STAT\_RX\_PACKET\_SMALL\_LSB: 0890

Bits	Default	Type	Signal
31:0	0	HIST	stat_rx_packet_small_count[31:0]

**STAT\_RX\_PACKET\_SMALL\_MSB: 0894**

Table 2-172: STAT\_RX\_PACKET\_SMALL\_MSB: 0894

Bits	Default	Type	Signal
15:0	0	HIST	stat_rx_packet_small_count[47:32]

**STAT\_RX\_UNDERSIZE\_LSB: 0898**

Table 2-173: STAT\_RX\_UNDERSIZE\_LSB: 0898

Bits	Default	Type	Signal
31:0	0	HIST	stat_rx_undersize_count[31:0]



**STAT\_RX\_UNDERSIZE\_MSB: 089C**

Table 2-174: STAT\_RX\_UNDERSIZE\_MSB: 089C

Bits	Default	Type	Signal
15:0	0	HIST	stat_rx_undersize_count[47:32]

**STAT\_RX\_FRAGMENT\_LSB: 08A0**

Table 2-175: STAT\_RX\_FRAGMENT\_LSB: 08A0

Bits	Default	Type	Signal
31:0	0	HIST	stat_rx_fragment_count[31:0]

**STAT\_RX\_FRAGMENT\_MSB: 08A4**

Table 2-176: STAT\_RX\_FRAGMENT\_MSB: 08A4

Bits	Default	Type	Signal
15:0	0	HIST	stat_rx_fragment_count[47:32]

**STAT\_RX\_OVERSIZE\_LSB: 08A8**

Table 2-177: STAT\_RX\_OVERSIZE\_LSB: 08A8

Bits	Default	Type	Signal
31:0	0	HIST	stat_rx_oversize_count[31:0]

**STAT\_RX\_OVERSIZE\_MSB: 08AC**

Table 2-178: STAT\_RX\_OVERSIZE\_MSB: 08AC

Bits	Default	Type	Signal
15:0	0	HIST	stat_rx_oversize_count[47:32]

**STAT\_RX\_TOOLONG\_LSB: 08B0**

Table 2-179: STAT\_RX\_TOOLONG\_LSB: 08B0

Bits	Default	Type	Signal
31:0	0	HIST	stat_rx_toolong_count[31:0]

**STAT\_RX\_TOOLONG\_MSB: 08B4**

Table 2-180: STAT\_RX\_TOOLONG\_MSB: 08B4

Bits	Default	Type	Signal
15:0	0	HIST	stat_rx_toolong_count[47:32]

**STAT\_RX\_JABBER\_LSB: 08B8**

Table 2-181: STAT\_RX\_JABBER\_LSB: 08B8

Bits	Default	Type	Signal
31:0	0	HIST	stat_rx_jabber_count[31:0]

**STAT\_RX\_JABBER\_MSB: 08BC**

Table 2-182: STAT\_RX\_JABBER\_MSB: 08BC

Bits	Default	Type	Signal
15:0	0	HIST	stat_rx_jabber_count[47:32]

**STAT\_RX\_BAD\_FCS\_LSB: 08C0**

Table 2-183: STAT\_RX\_BAD\_FCS\_LSB: 08C0

Bits	Default	Type	Signal
31:0	0	HIST	stat_rx_bad_fcs_count[31:0]

**STAT\_RX\_BAD\_FCS\_MSB: 08C4**

Table 2-184: STAT\_RX\_BAD\_FCS\_MSB: 08C4

Bits	Default	Type	Signal
15:0	0	HIST	stat_rx_bad_fcs_count[47:32]

**STAT\_RX\_PACKET\_BAD\_FCS\_LSB: 08C8**

Table 2-185: STAT\_RX\_PACKET\_BAD\_FCS\_LSB: 08C8

Bits	Default	Type	Signal
31:0	0	HIST	stat_rx_packet_bad_fcs_count[31:0]

**STAT\_RX\_PACKET\_BAD\_FCS\_MSB: 08CC**

Table 2-186: STAT\_RX\_PACKET\_BAD\_FCS\_MSB: 08CC

Bits	Default	Type	Signal
15:0	0	HIST	stat_rx_packet_bad_fcs_count[47:32]

**STAT\_RX\_STOMPED\_FCS\_LSB: 08D0**

Table 2-187: STAT\_RX\_STOMPED\_FCS\_LSB: 08D0

Bits	Default	Type	Signal
31:0	0	HIST	stat_rx_stomped_fcs_count[31:0]

**STAT\_RX\_STOMPED\_FCS\_MSB: 08D4**

Table 2-188: STAT\_RX\_STOMPED\_FCS\_MSB: 08D4

Bits	Default	Type	Signal
15:0	0	HIST	stat_rx_stomped_fcs_count[47:32]

**STAT\_RX\_UNICAST\_LSB: 08D8**

Table 2-189: STAT\_RX\_UNICAST\_LSB: 08D8

Bits	Default	Type	Signal
31:0	0	HIST	stat_rx_unicast_count[31:0]

**STAT\_RX\_UNICAST\_MSB: 08DC**

Table 2-190: STAT\_RX\_UNICAST\_MSB: 08DC

Bits	Default	Type	Signal
15:0	0	HIST	stat_rx_unicast_count[47:32]

**STAT\_RX\_MULTICAST\_LSB: 08E0**

Table 2-191: STAT\_RX\_MULTICAST\_LSB: 08E0

Bits	Default	Type	Signal
31:0	0	HIST	stat_rx_multicast_count[31:0]

**STAT\_RX\_MULTICAST\_MSB: 08E4**

Table 2-192: STAT\_RX\_MULTICAST\_MSB: 08E4

Bits	Default	Type	Signal
15:0	0	HIST	stat_rx_multicast_count[47:32]

**STAT\_RX\_BROADCAST\_LSB: 08E8**

Table 2-193: STAT\_RX\_BROADCAST\_LSB: 08E8

Bits	Default	Type	Signal
31:0	0	HIST	stat_rx_broadcast_count[31:0]

**STAT\_RX\_BROADCAST\_MSB: 08EC**

Table 2-194: STAT\_RX\_BROADCAST\_MSB: 08EC

Bits	Default	Type	Signal
15:0	0	HIST	stat_rx_broadcast_count[47:32]

**STAT\_RX\_VLAN\_LSB: 08F0**

Table 2-195: STAT\_RX\_VLAN\_LSB: 08F0

Bits	Default	Type	Signal
31:0	0	HIST	stat_rx_vlan_count[31:0]

**STAT\_RX\_VLAN\_MSB: 08F4**

Table 2-196: STAT\_RX\_VLAN\_MSB: 08F4

Bits	Default	Type	Signal
15:0	0	HIST	stat_rx_vlan_count[47:32]

**STAT\_RX\_PAUSE\_LSB: 08F8**

Table 2-197: STAT\_RX\_PAUSE\_LSB: 08F8

Bits	Default	Type	Signal
31:0	0	HIST	stat_rx_pause_count[31:0]

**STAT\_RX\_PAUSE\_MSB: 08FC**

Table 2-198: STAT\_RX\_PAUSE\_MSB: 08FC

Bits	Default	Type	Signal
15:0	0	HIST	stat_rx_pause_count[47:32]

**STAT\_RX\_USER\_PAUSE\_LSB: 0900**

Table 2-199: STAT\_RX\_USER\_PAUSE\_LSB: 0900

Bits	Default	Type	Signal
31:0	0	HIST	stat_rx_user_pause_count[31:0]

**STAT\_RX\_USER\_PAUSE\_MSB: 0904**

Table 2-200: STAT\_RX\_USER\_PAUSE\_MSB: 0904

Bits	Default	Type	Signal
15:0	0	HIST	stat_rx_user_pause_count[47:32]

**STAT\_RX\_INRANGEERR\_LSB: 0908**

Table 2-201: STAT\_RX\_INRANGEERR\_LSB: 0908

Bits	Default	Type	Signal
31:0	0	HIST	stat_rx_inrangeerr_count[31:0]

**STAT\_RX\_INRANGEERR\_MSB: 090C**

Table 2-202: STAT\_RX\_INRANGEERR\_MSB: 090C

Bits	Default	Type	Signal
15:0	0	HIST	stat_rx_inrangeerr_count[47:32]

**STAT\_RX\_TRUNCATED\_LSB: 0910**

Table 2-203: STAT\_RX\_TRUNCATED\_LSB: 0910

Bits	Default	Type	Signal
31:0	0	HIST	stat_rx_truncated_count[31:0]

**STAT\_RX\_TRUNCATED\_MSB: 0914**

Table 2-204: STAT\_RX\_TRUNCATED\_MSB: 0914

Bits	Default	Type	Signal
15:0	0	HIST	stat_rx_truncated_count[47:32]

**STAT\_RX\_TEST\_PATTERN\_MISMATCH\_LSB: 0918**

Table 2-205: STAT\_RX\_TEST\_PATTERN\_MISMATCH\_LSB: 0918

Bits	Default	Type	Signal
31:0	0	HIST	stat_rx_test_pattern_mismatch_count[31:0]

**STAT\_RX\_TEST\_PATTERN\_MISMATCH\_MSB: 091C**

Table 2-206: STAT\_RX\_TEST\_PATTERN\_MISMATCH\_MSB: 091C

Bits	Default	Type	Signal
15:0	0	HIST	stat_rx_test_pattern_mismatch_count[47:32]

# Designing with the Subsystem

This chapter includes guidelines and additional information to facilitate designing with the core.

---

## General Design Guidelines

### Use the Example Design as a Starting Point

Each release is delivered as a complete reference design that includes a sample test bench for simulation. Transceivers are included, targeted to the particular Xilinx device requested for that release. In most cases, you need to re-assign the transceivers according to the device pinout specific to your board layout. You might also wish to generate new custom transceivers using the Vivado<sup>®</sup> Design Suite with characteristics suited to your board.

### Know the Degree of Difficulty

Xilinx<sup>®</sup> USXGMII core designs are challenging to implement in any technology, and the degree of difficulty is further influenced by:

- Maximum system clock frequency
- Targeted device architecture
- Nature of your application

All USXGMII core implementations need careful attention to system performance requirements. Pipelining, logic mapping, placement constraints, and logic duplication are all methods that help boost system performance.

### Keep it Registered

To simplify timing and increase system performance in an FPGA design, keep all inputs and outputs registered between your application and the core. This means that all inputs and outputs from your application should come from, or connect to a flip-flop. While registering signals cannot be possible for all paths, it simplifies timing analysis and makes it easier for the Vivado Design Suite to place and route the design.

## Recognize Timing Critical Signals

The timing constraints file that is provided with the example design for the core identifies the critical signals and the timing constraints that should be applied.

## Make Only Allowed Modifications

The USXGMII core is not user-modifiable. Do not make any modifications because these modifications can have adverse effects on system timing and protocol functionality. You can submit supported user configurations of the USXGMII core to Xilinx Technical Support for implementation.

You are encouraged to modify the transceivers included with the example design. Use the latest GT Wizard which is part of the Vivado Design Suite. Some features that might need to be customized are the transceiver placement, reference clocks, and optional ports, among others.



## Clocking and Resets

The 32-bit USXGMII IP core MAC is configured to operate its RX side on a single RX recovered clock (async gearbox option on the GTH or GTY transceiver for a bubble-less data path running with a 312.5 MHz clock).

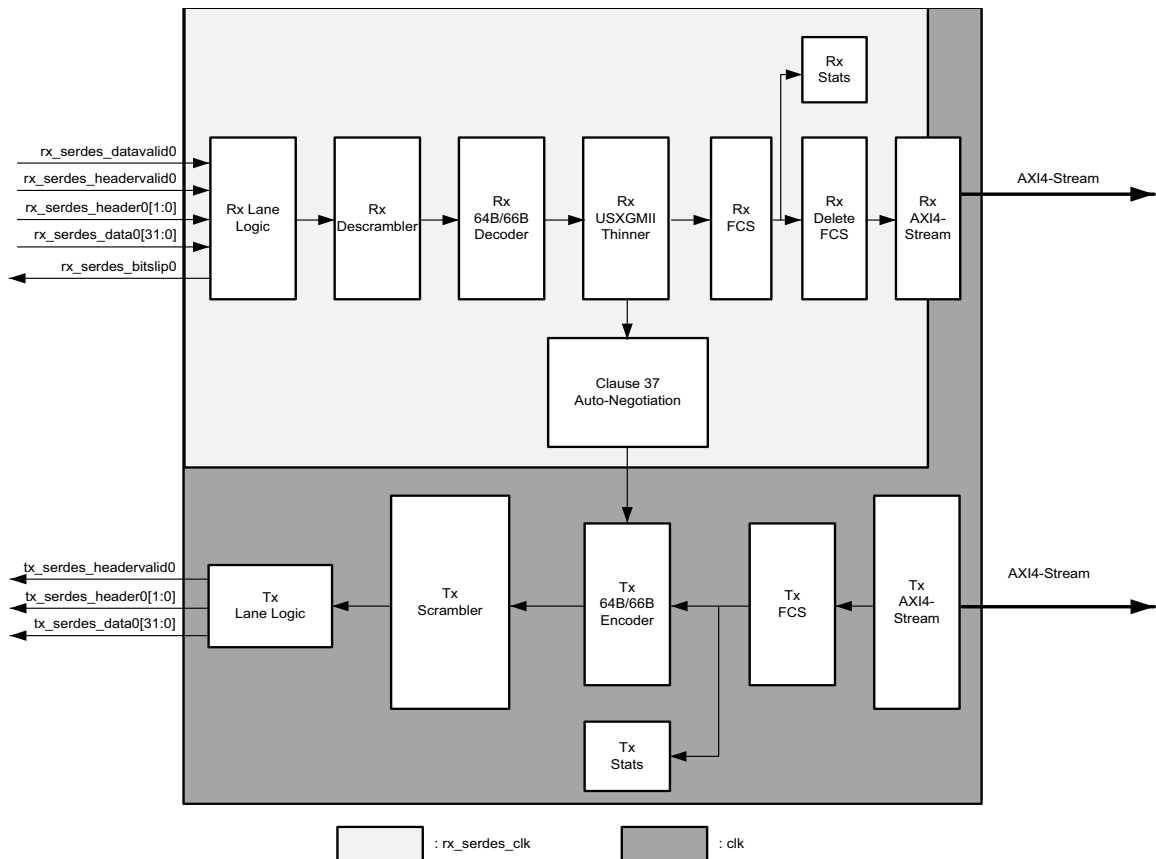

X17162-032019

Figure 3-1: Clocking and Reset

The entire TX side and the AXI4-Stream interface run on a single 312.5 MHz clock. This clock is provided to user logic on the `tx_clk_out` port.

All signals between the USXGMII IP core and the user-side RX logic are synchronized to the positive edge of the `rx_clk_out` clock, which is set to a frequency of 312.5 MHz. When the RX FIFO is included, `rx_clk_out` will not be present and the RX path will be synchronized to `tx_clk_out`.

The IP core has a simple reset structure. The single `tx_reset` input is asserted High to reset the TX data path. This reset can be deasserted when the `clk` clock is stable.

The RX GT interface logic is reset by asserting the `rx_serdes_reset` signal. The `rx_reset` signal resets the internal RX data path. When the `clk` clock is stable, the `rx_reset` can be released. Following that when the `rx_serdes_clk` is stable the `rx_serdes_reset` can be released.

## Support for IEEE Standard 1588v2

### Overview

This section details the packet timestamping function of the USXGMII subsystem. The timestamping option must be specified at the time of generating the subsystem from the IP catalog or ordering the IP Core asynchronously.

Only two-step IEEE 1588v2 functionality is supported. When the core is generated with timestamping support, the two-step related ports will be populated and the core will perform two-step time stamping functionality.

Ethernet frames are timestamped at both ingress and egress. The option can be used for implementing all kinds of IEEE 1588v2 clocks: Ordinary, Transparent, and Boundary. It can also be used for the generic timestamping of packets at the ingress and egress ports of a system. While this feature can be used for a variety of packet timestamping applications, the rest of this section assumes that you are also implementing the IEEE 1588v2 Precision Time Protocol (PTP).

IEEE 1588v2 defines a protocol for performing timing synchronization across a network. A 1588 network has a single master clock timing reference, usually selected through a best master clock algorithm. Periodically, this master samples its system timer reference counter, and transmits this sampled time value across the network using defined packet formats. This timer should be sampled (a timestamp) when the start of a 1588 timing packet is transmitted. Therefore, to achieve high synchronization accuracy over the network, accurate timestamps are required. If this sampled timer value (the timestamp) is placed into the packet that triggered the timestamp, this is known as one-step operation. Alternatively, the timestamp value can be placed into a follow up packet; this is known as two-step operation.

Other timing slave devices on the network receive these timing reference packets from the network timing master and attempt to synchronize their own local timer references to it. This mechanism relies on these Ethernet ports also taking timestamps (samples of their own local timer) when the 1588 timing packets are received. Further explanation of the operation of 1588 is out of scope of this document. This document now describes the 1588 hardware timestamping features of the subsystem.

The 1588 timer provided to the subsystem and the consequential timestamping taken from it are available in one of two formats:

- Time-of-Day (ToD) format: IEEE 1588-2008 format consisting of an unsigned 48-bit second field and a 32-bit nanosecond field.
- Correction Field format: IEEE 1588-2008 numerical format consisting of a 64-bit signed field representing nanoseconds multiplied by 216 (see IEEE 1588 clause 13.3.2.7). This timer should count from 0 through the full range up to 264 -1 before wrapping around.

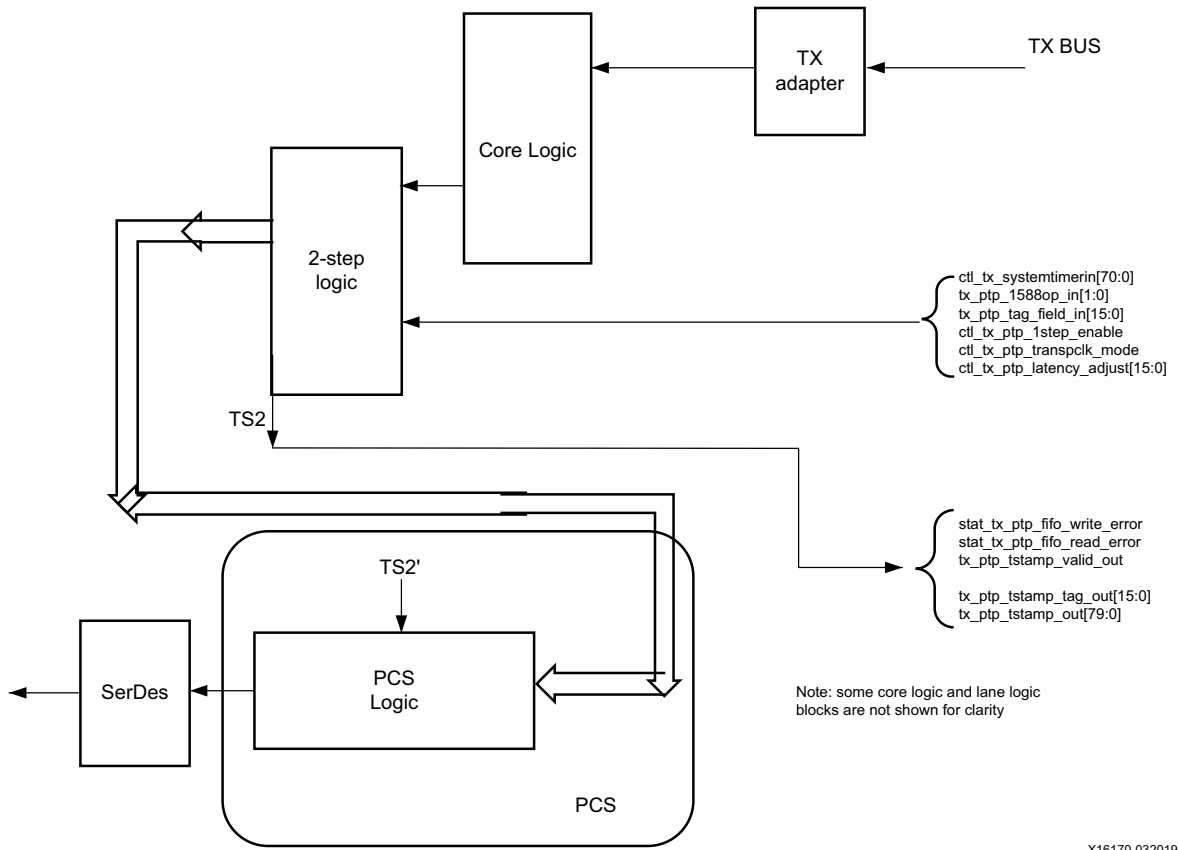

Figure 3-2: Egress

Figure 3-2 shows the point in the TX datapath where the two-step operation is performed. The time stamp references are defined as follows:

- TS2: The output timestamp signal when a two-step operation is selected.
- TS2': The plane to which both timestamps are corrected.

TS2 has a correction applied so that it is referenced to the TS2' plane, depending on the value of the signal `ct1_tx_ptp_latency_adjust[15:0]`.

On the transmit side, a command field is provided by the client to the subsystem in parallel with the frame sent for transmission. This indicates, on a frame-by-frame basis, the 1588 function to perform (either no-operation or two-step). If using the ToD format, then for both one-step and two-step operation, the full captured 80-bit ToD timestamp is returned to the client logic using the additional ports defined in Table 3-1. If using the Correction Field format, then for both one-step and two-step operation, the full captured 64-bit timestamp is returned to the client logic using the additional ports defined in Table 3-1 (with the upper bits of data set to zero as defined in the table).

## Frame-by-Frame Timestamping Operation

The operational mode of the egress timestamping function is determined by the settings on the 1588 command port. The information contained within the command port indicates one of the following:

- No operation: the frame is not a PTP frame and no timestamp action should be taken.
- Two-step operation is required and a tag value (user-sequence ID) is provided as part of the command field; the frame should be timestamped, and the timestamp made available to the client logic, along with the provided tag value for the frame. The additional MAC transmitter ports provide this function.

### Ingress

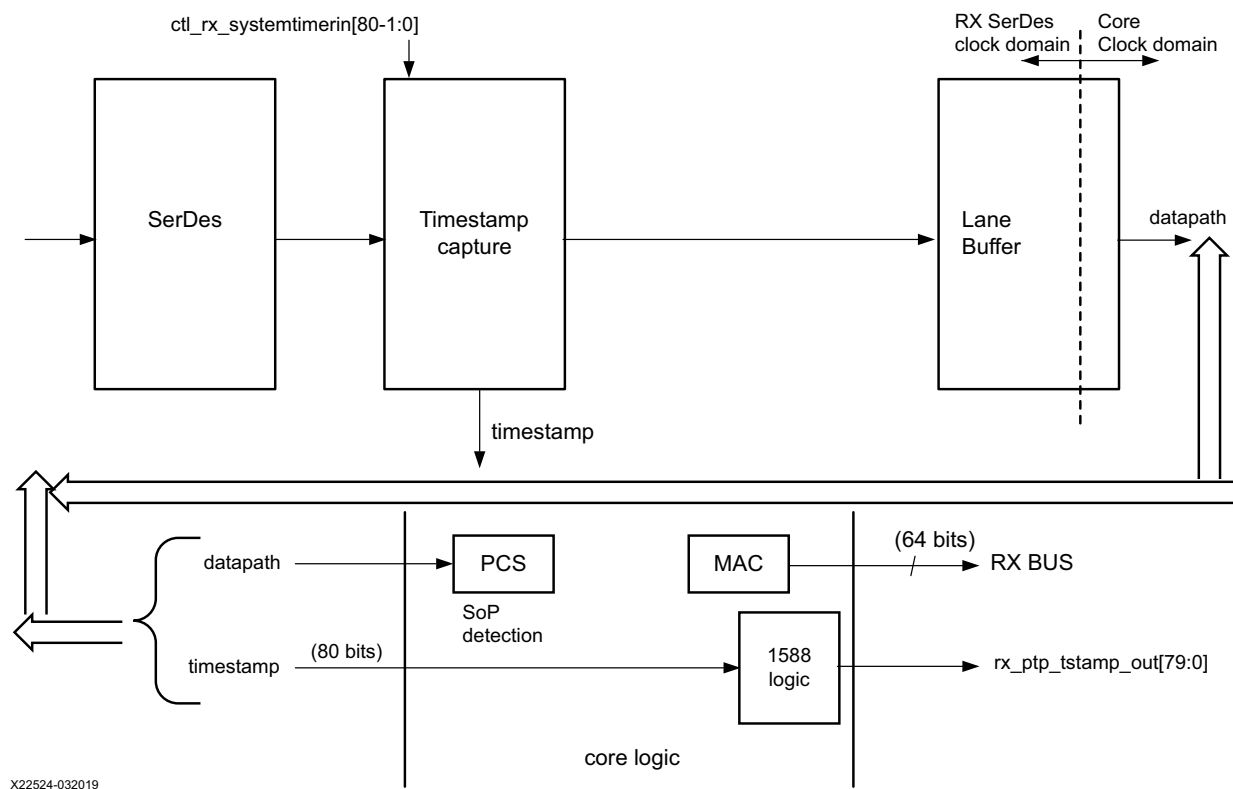

Figure 3-3: Ingress

The ingress logic does not parse the ingress packets to search for 1588 precise timing protocol (PTP) frames. Instead, it takes a timestamp for every received frame and outputs this value to the user logic. The feature is always enabled, but the timestamp output can be ignored if you do not require this function.

Timestamps are filtered after the PCS decoder to retain only those timestamps corresponding to a Start of Packet (SOP). These 80-bit timestamps are output on the system side. The timestamp is valid during the SOP cycle and when `ena_out = 1`.

## Port Descriptions

Table 3-1 details the additional signals present when the packet timestamping feature is included.

Table 3-1: 1588v2 Port List and Descriptions

Name	Direction	Clock Domain	Description
<b>IEEE 1588 Interface – TX Path</b>			
<code>ctl_tx_systemtimerin[79:0]</code>	Input	<code>tx_serdes_clk</code>	System timer input for the TX. In normal clock mode, the 32 LSBs carry nsec and the 48 MSBs carry seconds. In transparent clock mode, bit 63 is expected to be zero, bits 62:16 carry nanoseconds, and bits 15:0 carry fractional nanoseconds. Refer to IEEE 1588v2 for the representational definitions. This input must be in the TX SerDes clock domain.
<code>tx_ptp_tstamp_valid_out</code>	Output	<code>tx_clk_out</code>	This bit indicates that a valid timestamp is being presented on the TX system interface.
<code>tx_ptp_tstamp_tag_out[15:0]</code>	Output	<code>tx_clk_out</code>	Tag output corresponding to <code>tx_ptp_tag_field_in[15:0]</code>
<code>tx_ptp_tstamp_out[79:0]</code>	Output	<code>tx_clk_out</code>	Timestamp for the transmitted packet SOP corresponding to the time at which it passed the capture plane. Time format same as timer input.
<code>tx_ptp_1588op_in[1:0]</code>	Input	<code>tx_clk_out</code>	The signal should be valid on the first cycle of the packet. <ul style="list-style-type: none"> <li>• 2'b00 – No operation: no timestamp will be taken and the frame will not be modified.</li> <li>• 2'b10 – 2-step: a timestamp should be taken and returned to the client using the additional ports of 2-step operation. The frame itself will not be modified.</li> <li>• 2'b01 and 2'b11 – Reserved: act as No operation.</li> </ul>
<code>ctl_tx_ptp_1step_enable</code>	Input	<code>tx_clk_out</code>	This signal should be tied to 1'b0
<code>ctl_ptp_transpclk_mode</code>	Input	<code>tx_clk_out</code>	When set to 1, this input places the timestamping logic into transparent clock mode.

Table 3-1: 1588v2 Port List and Descriptions (Cont'd)

Name	Direction	Clock Domain	Description
tx_ptp_tag_field_in[15:0]	Input	tx_clk_out	The usage of this field is dependent on the 1588 operation. The signal should be valid on the first cycle of the packet. <ul style="list-style-type: none"> <li>For No operation, this field will be ignored.</li> <li>For two-step this field is a tag field. This tag value will be returned to the client with the timestamp for the current frame using the additional ports of two-step operation. This tag value can be used by software to ensure that the timestamp can be matched with the PTP frame that it sent for transmission.</li> </ul>
ctl_tx_ptp_latency_adjust[31:0]	Input	tx_clk_out	This bus can be used to adjust the one-step T timestamp with respect to the two-step timestamp. Only the LSB 16-bits are used.
stat_tx_ptp_fifo_write_error	Output	tx_clk_out	Transmit PTP FIFO write error. A value of 1 on this status indicates that an error occurred during the PTP Tag write. A TX Path reset is required to clear the error.
stat_tx_ptp_fifo_read_error	Output	tx_clk_out	Transmit PTP FIFO read error. A value of 1 on this status indicates that an error occurred during the PTP Tag read. A TX Path reset is required to clear the error.
tx_ptp_rxtstamp_in	Input	tx_clk_out	At present this port is not used. Should be tied to 0x0.
<b>IEEE 1588 Interface – RX Path</b>			
ctl_rx_systemtimerin[79:0]	Input	rx_serdes_clk	System timer input for the RX. Same time format as the TX. This input must be in the same clock domain as the RX SerDes.
rx_ptp_tstamp_out[79:0]	Output	rx_clk_out	Timestamp for the received packet SOP corresponding to the time at which it passed the capture plane. Note that this signal will be valid on the first cycle of the packet.

## Pause Processing

The USXGMII core provides a comprehensive mechanism for pause packet termination and generation. The TX and RX have independent interfaces for processing pause information as described in this section.

### TX Pause Generation

You can request a pause packet to be transmitted using the `ctl_tx_pause_req[8:0]` and `ctl_tx_pause_enable[8:0]` input buses. Bit [8] corresponds to global pause packets and bits [7:0] correspond to priority pause packets.

Each bit of this bus must be held at a steady state for a minimum of 16 cycles before the next transition.



**CAUTION!** *Requesting both global and priority pause packets at the same time results in unpredictable behavior and must be avoided.*

The contents of the pause packet are determined using the following input pins.

Global pause packets:

```
ctl_tx_da_gpp[47:0]
ctl_tx_sa_gpp[47:0]
ctl_tx_ethertype_gpp[15:0]
ctl_tx_opcode_gpp[15:0]
ctl_tx_pause_quanta8[15:0]
```

Priority pause packets:

```
ctl_tx_da_ppp[47:0]
ctl_tx_sa_ppp[47:0]
ctl_tx_ethertype_ppp[15:0]
ctl_tx_opcode_ppp[15:0]
ctl_tx_pause_quanta0[15:0]
ctl_tx_pause_quanta1[15:0]
ctl_tx_pause_quanta2[15:0]
ctl_tx_pause_quanta3[15:0]
ctl_tx_pause_quanta4[15:0]
ctl_tx_pause_quanta5[15:0]
ctl_tx_pause_quanta6[15:0]
ctl_tx_pause_quanta7[15:0]
```

The USXGMII core automatically calculates and adds the FCS to the packet. For priority pause packets the USXGMII core also automatically generates the enable vector based on the priorities that are requested.

To request a pause packet, you must set the corresponding bit of the `ctl_tx_pause_req[8:0]` and `ctl_tx_pause_enable[8:0]` bus to a 1 and keep it at 1 for the duration of the pause request (that is, if these inputs are set to 0, all pending pause packets are canceled). The USXGMII core transmits the pause packet immediately after the current packet in flight is completed.



---

**IMPORTANT:** *Each bit of this bus must be held at a steady state for a minimum of 16 cycles before the next transition.*

---

To retransmit pause packets, the USXGMII core maintains a total of nine independent timers; one for each priority and one for global pause. These timers are loaded with the value of the corresponding input buses. After a pause packet is transmitted the corresponding timer is loaded with the corresponding value of the `ctl_tx_pause_refresh_timer[8:0]` input bus. When a timer times out, another packet for that priority (or global) is transmitted as soon as the current packet in flight is completed. Additionally, you can manually force the timers to 0, and therefore force a retransmission, by setting the `ctl_tx_resend_pause` input to 1 for one clock cycle.

To reduce the number of pause packets for priority mode operation, a timer is considered timed out if any of the other timers time out. Additionally, while waiting for the current packet in flight to be completed, any new timer that times out or any new requests are merged into a single pause frame. For example, if two timers are counting down, and you send a request for a third priority, the two timers are forced to be timed out and a pause packet for all three priorities is sent as soon as the current in-flight packet (if any) is transmitted. Similarly, if one of the two timers times out without an additional request, both timers are forced to be timed out and a pause packet for both priorities is sent as soon as the current in-flight packet (if any) is transmitted.

You can stop pause packet generation by setting the appropriate bits of `ctl_tx_pause_req[8:0]` or `ctl_tx_pause_enable[8:0]` to 0.



## RX Pause Termination

The USXGMII core terminates global and priority pause frames and provides a simple hand-shaking interface to allow user logic to respond to pause packets.

### Determining Pause Packets

There are three steps in determining pause packets:

1. Checks are performed to see if a packet is a global or a priority control packet.

Packets that pass step 1 are forwarded to you only if `ctl_rx_forward_control` is set to 1.

2. If step 1 passes, the packet is checked to determine if it is a global pause packet.
3. If step 2 fails, the packet is checked to determine if it is a priority pause packet.

For [step 1](#), the following pseudo code shows the checking function:

```
assign da_match_gcp = (!ctl_rx_check_mcast_gcp && !ctl_rx_check_ucast_gcp) || ((DA
== ctl_rx_pause_da_ucast) && ctl_rx_check_ucast_gcp) || ((DA == 48'h0180c2000001) &&
ctl_rx_check_mcast_gcp);
assign sa_match_gcp = !ctl_rx_check_sa_gcp || (SA == ctl_rx_pause_sa);
assign etype_match_gcp = !ctl_rx_check_etype_gcp || (ETYPE == ctl_rx_etype_gcp);
assign opcode_match_gcp = !ctl_rx_check_opcode_gcp || ((OPCODE >=
ctl_rx_opcode_min_gcp) && (OPCODE <= ctl_rx_opcode_max_gcp));
assign global_control_packet = da_match_gcp && sa_match_gcp && etype_match_gcp &&
opcode_match_gcp && ctl_rx_enable_gcp;
assign da_match_pcp = (!ctl_rx_check_mcast_pcp && !ctl_rx_check_ucast_pcp) || ((DA
== ctl_rx_pause_da_ucast) && ctl_rx_check_ucast_pcp) || ((DA ==
ctl_rx_pause_da_mcast) && ctl_rx_check_mcast_pcp);
assign sa_match_pcp = !ctl_rx_check_sa_pcp || (SA == ctl_rx_pause_sa);
assign etype_match_pcp = !ctl_rx_check_etype_pcp || (ETYPE == ctl_rx_etype_pcp);
assign opcode_match_pcp = !ctl_rx_check_opcode_pcp || ((OPCODE >=
ctl_rx_opcode_min_pcp) && (OPCODE <= ctl_rx_opcode_max_pcp));
assign priority_control_packet = da_match_pcp && sa_match_pcp && etype_match_pcp &&
opcode_match_pcp && ctl_rx_enable_pcp;
assign control_packet = global_control_packet || priority_control_packet;
```

where DA is the destination address, SA is the source address, OPCODE is the opcode and ETYPE is the ethertype/length field that are extracted from the incoming packet.

For [step 2](#), the following pseudo code shows the checking function:

```
assign da_match_gpp = (!ctl_rx_check_mcast_gpp && !ctl_rx_check_ucast_gpp) || ((DA
== ctl_rx_pause_da_ucast) && ctl_rx_check_ucast_gpp) || ((DA == 48'h0180c2000001) &&
ctl_rx_check_mcast_gpp);
assign sa_match_gpp = !ctl_rx_check_sa_gpp || (SA == ctl_rx_pause_sa);
assign etype_match_gpp = !ctl_rx_check_etype_gpp || (ETYPE == ctl_rx_etype_gpp);
assign opcode_match_gpp = !ctl_rx_check_opcode_gpp || (OPCODE == ctl_rx_opcode_gpp);
assign global_pause_packet = da_match_gpp && sa_match_gpp && etype_match_gpp &&
opcode_match_gpp && ctl_rx_enable_gpp;
```

where DA is the destination address, SA is the source address, OPCODE is the opcode and ETYPE is the ethertype/length field that are extracted from the incoming packet.

For [step 3](#), the following pseudo code shows the checking function:

```
assign da_match_ppp = (!ctl_rx_check_mcast_ppp && !ctl_rx_check_ucast_ppp) || ((DA
== ctl_rx_pause_da_ucast) && ctl_rx_check_ucast_ppp) || ((DA ==
ctl_rx_pause_da_mcast) && ctl_rx_check_mcast_ppp);
assign sa_match_ppp = !ctl_rx_check_sa_ppp || (SA == ctl_rx_pause_sa);
assign etype_match_ppp = !ctl_rx_check_etype_ppp || (ETYPE == ctl_rx_etype_ppp);
assign opcode_match_ppp = !ctl_rx_check_opcode_ppp || (OPCODE == ctl_rx_opcode_ppp);
assign priority_pause_packet = da_match_ppp && sa_match_ppp && etype_match_ppp &&
opcode_match_ppp && ctl_rx_enable_ppp;
```

where DA is the destination address, SA is the source address, OPCODE is the opcode and ETYPE is the ethertype/length field that are extracted from the incoming packet.

## User Interface

A simple handshaking protocol is used to alert you of the reception of pause packets using the `ctl_rx_pause_enable[8:0]`, `stat_rx_pause_req[8:0]` and `ctl_rx_pause_ack[8:0]` buses. For these buses, bit [8] corresponds to global pause packets and bits [7:0] correspond to priority pause packets.

The following steps occur when a pause packet is received:

1. If the corresponding bit of `ctl_rx_pause_enable[8:0]` is 0, the quanta is ignored and the hard CMAC stays in step 1. Otherwise, the corresponding bit of the `stat_rx_pause_req[8:0]` bus is set to 1, and the received quanta is loaded into a timer.

If one of the bits of `ctl_rx_pause_enable[8:0]` is set to 0 (disabled) when the pause processing is in [step 2](#) or later, the core completes the steps as normal until it comes back to [step 1](#).

2. If `ctl_rx_check_ack` input is 1, the core waits for you to set the appropriate bit of the `ctl_rx_pause_ack[8:0]` bus to 1.
3. After you set the proper bit of `ctl_rx_pause_ack[8:0]` to 1, or if `ctl_rx_check_ack` is 0, the core starts counting down the timer.
4. When the timer times out, the core sets the appropriate bit of `stat_rx_pause_req[8:0]` back to 0.
5. If `ctl_rx_check_ack` input is 1, the operation is complete when you set the appropriate bit of `ctl_rx_pause_ack[8:0]` back to 0.

If you do not set the appropriate bit of `ctl_rx_pause_ack[8:0]` back to 0, the core deems the operation complete after 32 clock cycles.

These steps are demonstrated in Figure 3-4 with each step shown on the waveform.

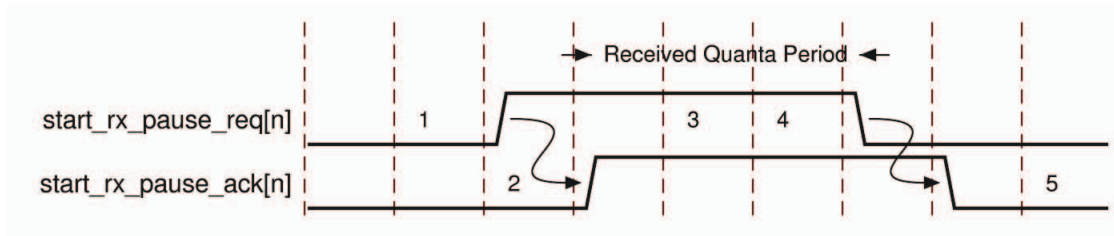

Figure 3-4: RX Pause Interface Example

If at any time during step 2 to step 5 a new pause packet is received, the timer is loaded with the newly acquired quanta value and the process continues.

# Design Flow Steps

---

## Customizing and Generating the Core

This core is not delivered in the Vivado<sup>®</sup> Design Suite.

This chapter describes customizing and generating the core, constraining the core, and the simulation, synthesis and implementation steps that are specific to this IP core. More detailed information about the standard Vivado design flows and the IP integrator can be found in the following Vivado Design Suite user guides:

- *Vivado Design Suite User Guide: Designing IP Subsystems using IP Integrator* (UG994) [\[Ref 2\]](#)
  - *Vivado Design Suite User Guide: Designing with IP* (UG896) [\[Ref 3\]](#)
  - *Vivado Design Suite User Guide: Getting Started* (UG910) [\[Ref 5\]](#)
  - *Vivado Design Suite User Guide: Logic Simulation* (UG900) [\[Ref 6\]](#)
- 

## Customizing and Generating the Core

This section includes information about using Xilinx tools to customize and generate the core in the Vivado Design Suite.

If you are customizing and generating the core in the Vivado IP integrator, see the *Vivado Design Suite User Guide: Designing IP Subsystems using IP Integrator* (UG994) [\[Ref 2\]](#) for detailed information. IP integrator might auto-compute certain configuration values when validating or generating the design. To check whether the values do change, see the description of the parameter in this chapter. To view the parameter value, run the `validate_bd_design` command in the Tcl console.

You can customize the IP for use in your design by specifying values for the various parameters associated with the IP core using the following steps:

1. Select the IP from the Vivado IP catalog.
2. Double-click the selected IP or select the **Customize IP** command from the toolbar or right-click menu.

For details, see the *Vivado Design Suite User Guide: Designing with IP* (UG896) [Ref 3] and the *Vivado Design Suite User Guide: Getting Started* (UG910) [Ref 5].

**Note:** Figures in this chapter are illustrations of the Vivado Integrated Design Environment (IDE). The layout depicted here might vary from the current version.

## Configuration Tab

The Configuration tab (Figure 4-1) provides the basic core configuration options. Default values are pre-populated in all tabs.

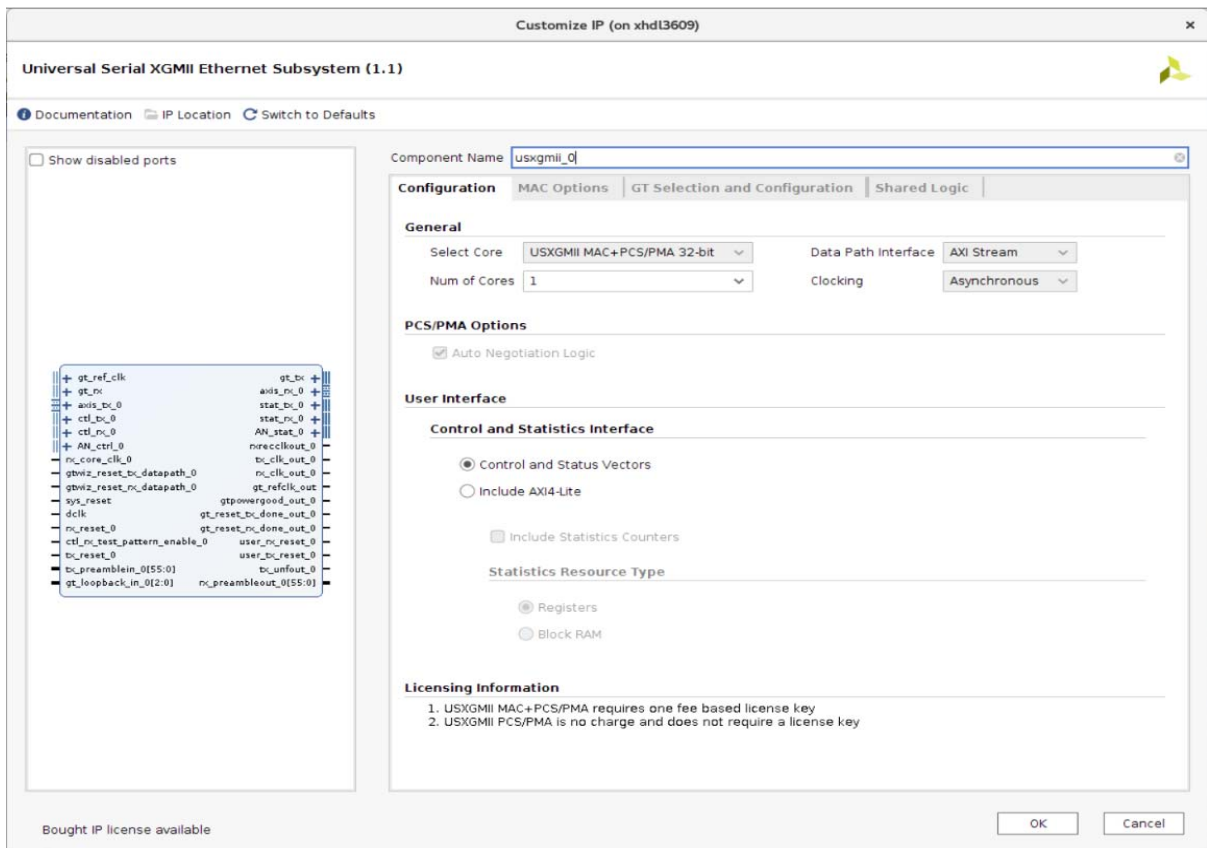

Figure 4-1: Configuration Tab

Table 4-1: Configuration Options

Option	Values	Default
<b>General</b>		
Select Core	USXGMII MAC+PCS/PMA 32-bit	USXGMII MAC+PCS/PMA 32-bit
Data Path Interface	AXI4-Stream <sup>(1)</sup>	AXI-Stream
Num of Cores	1 2 3 4	1
Clocking	Asynchronous <sup>(2)</sup>	Asynchronous
<b>PCS/PMA Options</b>		
Auto Negotiation Logic	Checked <sup>(3)</sup>	Checked
<b>Control and Statistics Interface</b>		
Control and Statistics interface	Control and Status Vectors Include AXI4-Lite	Control and Status Vectors
Include Statistics Counters	Checked and Unchecked <sup>(4)</sup>	Checked
Statistics Resource Type <sup>(5)</sup>	Registers, block RAM	Registers

**Notes:**

1. The AXI4-Stream interface is visible and is the only available option.
2. Asynchronous clocking is the only option available. In this mode TXOUTCLK sources the TXUSRCLK and RXOUTCLK sources the RXUSRCLK.
3. The USXGMII standard mandates that the auto negotiation logic is always enabled. You can assert the core input signal, `ct1_umi_an_bypass`, to by-pass auto negotiation logic and run the core at a fixed data-rate.
4. The Statistics Counters are available in the register map only when you enable the Include Statistics Counters option. Otherwise, the Statistics Counters are not available.
5. Statistics Resource Type block RAM option inclusion is planned for future release.

## MAC Options Tab

The MAC Options tab (Figure 4-2) provides additional core configuration options.

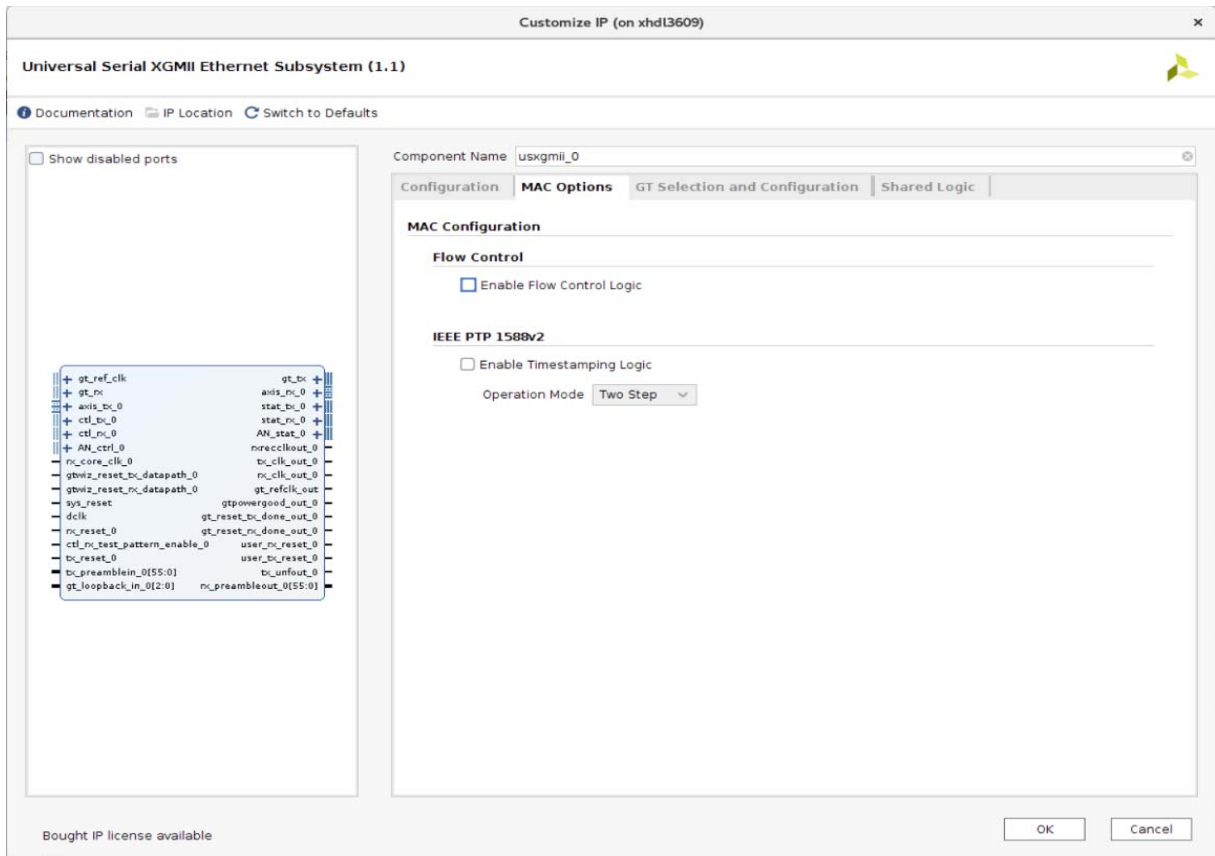

Figure 4-2: MAC Options Tab

Table 4-2: MAC Options

Option	Values	Default
<b>Flow Control</b>		
Enable Flow Control Logic	Checked, Unchecked	Unchecked
<b>IEEE PTP 1588v2</b>		
Enable Timestamping Logic	Checked, Unchecked	Unchecked
Operation Mode	Two Step	Two Step

## GT Selection and Configuration Tab

The GT Selection and Configuration tab (Figure 4-3) enables you to configure the serial transceiver features of the core.

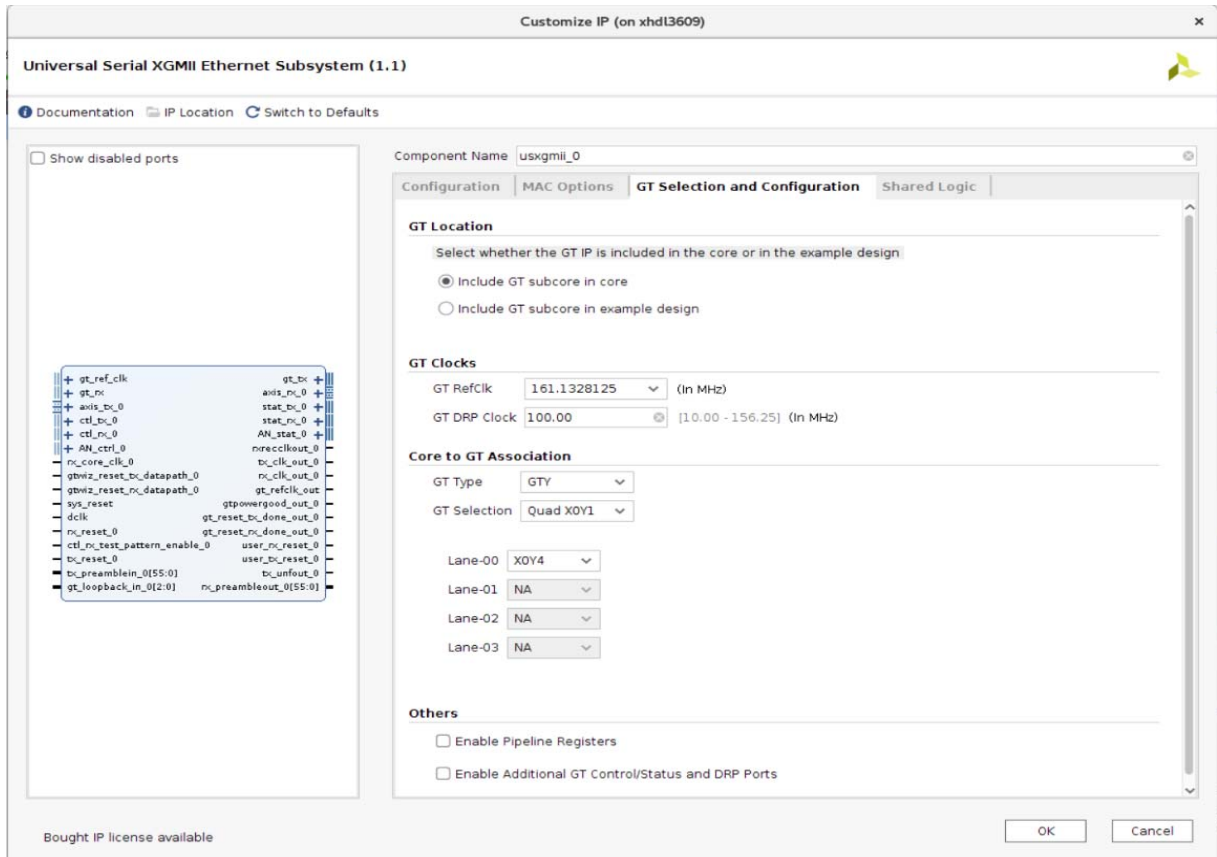

Figure 4-3: GT Selection and Configuration Tab



Table 4-3: GT Selection and Configuration Options

Option	Values	Default
<b>GT Location</b>		
Select whether the GT IP is included in the core or in the example design	Include GT subcore in core Include GT subcore in example design	Include GT subcore in core
<b>GT Clocks</b>		
GT RefClk (In MHz)	103.125 128.90625 156.25 161.1328125 206.25 257.8125 309.375 312.5 322.265625	156.25
GT DRP Clock (In MHz)	10 – 250 MHz	100
<b>Core to GT Association</b>		
GT Type	GTY GTH	GTY
GT Selection	Options based on device/ package Quad groups. For example: Quad X0Y1 Quad X0Y2 Quad X0Y3 ...	Quad X0Y1
Lane-00 to Lane-03	Auto filled based on device/ package. For example, if Num of Core = 4, and GT Selection = Quad X0Y1, four lanes are: X0Y4 X0Y5 X0Y6 X0Y7	
<b>Others</b>		
Enable Pipeline Registers	Checked, Unchecked	Unchecked
Enable Additional GT Control/ Status and DRP Ports	Checked, Unchecked	Unchecked

## Shared Logic Tab

The Shared Logic tab allows you to use shared logic in either the core or the example design.

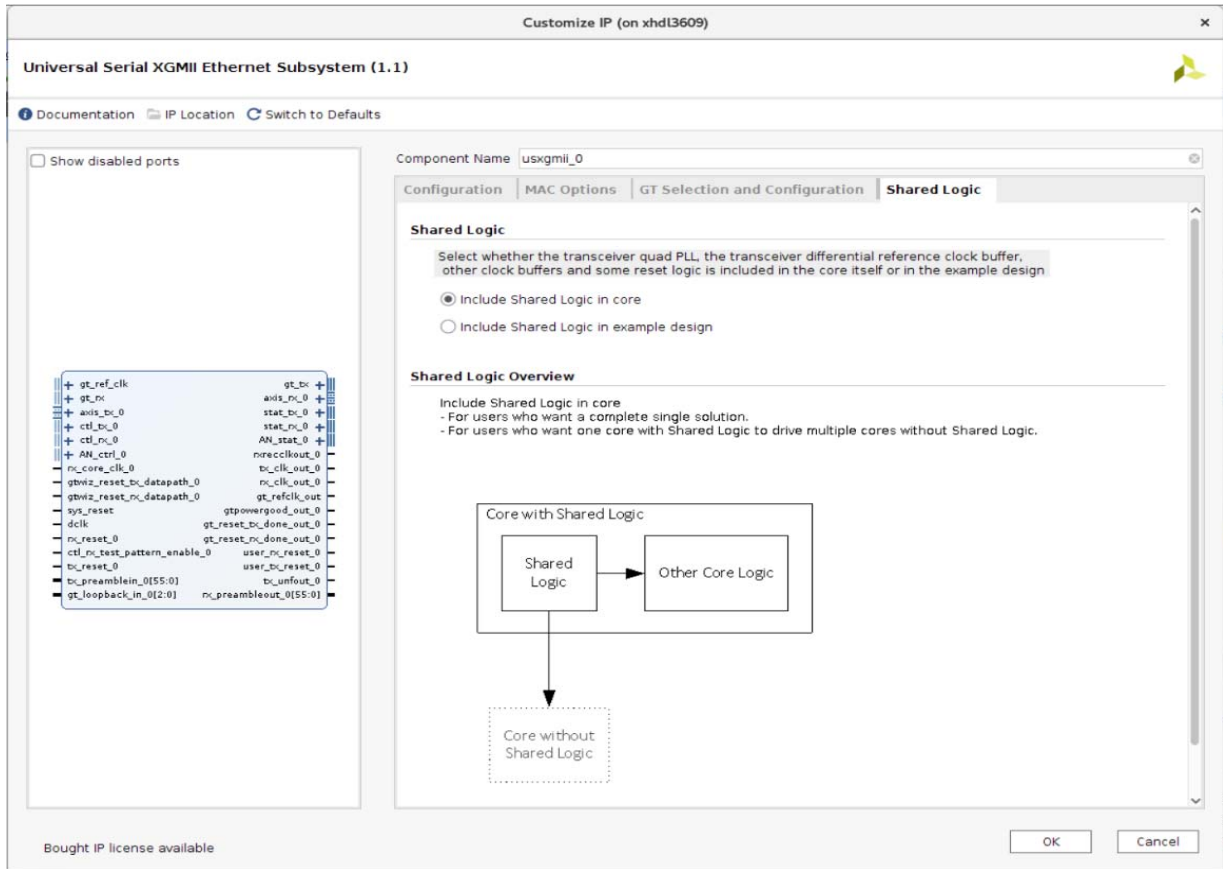

Figure 4-4: Shared Logic Tab

Table 4-4: Shared Logic Options

Options	Default
Include Shared Logic in core	Include Shared Logic in core
Include Shared Logic in example design	

## Output Generation

For details, see the *Vivado Design Suite User Guide: Designing with IP* (UG896) [Ref 3].

## User Parameters

Table 4-5 shows the relationship between the Vivado IDE and the user parameters (which can be viewed in the Tcl console).

Table 4-5: Vivado IDE Parameter to User Parameter Relationship

Vivado IDE Parameter/Value <sup>(1)</sup>	User Parameter/Value <sup>(1)</sup>	Default Value
CORE USXGMII MAC+PCS/PMA 32-bit	CORE USXGMII MAC+PCS/PMA 32-bit	USXGMII MAC+PCS/PMA 32-bit
NUM_OF_CORES 1 2 3 4	NUM_OF_CORES 1 2 3 4	1
CLOCKING Asynchronous	CLOCKING Asynchronous	"Asynchronous"
DATA_PATH_INTERFACE AXI Stream	DATA_PATH_INTERFACE AXI Stream	"AXI Stream"
INCLUDE_AUTO_NEG_LOGIC True	INCLUDE_AUTO_NEG_LOGIC 1	1
INCLUDE_AXI4_INTERFACE Control and Status Vectors Include AXI4-Lite	INCLUDE_AXI4_INTERFACE 0 1	0
INCLUDE_STATISTICS_COUNTER True False	INCLUDE_STATISTICS_COUNTER 0 1	1
ENABLE_FLOW_CONTROL_LOGIC True False	ENABLE_FLOW_CONTROL_LOGIC 0 1	0
ENABLE_TIME_STAMPING True False	ENABLE_TIME_STAMPING 0 1	0
PTP_OPERATION_MODE Two Step	PTP_OPERATION_MODE 2	2
PTP_CLOCKING_MODE Ordinary Clock Transparent Clock	PTP_CLOCKING_MODE 0 1	0
TX_LATENCY_ADJUST TRUE FALSE	TX_LATENCY_ADJUST 1 0	0

Table 4-5: Vivado IDE Parameter to User Parameter Relationship (Cont'd)

Vivado IDE Parameter/Value <sup>(1)</sup>	User Parameter/Value <sup>(1)</sup>	Default Value
ENABLE_VLANE_ADJUST_MODE TRUE FALSE	ENABLE_VLANE_ADJUST_MODE 1 0	0
GT_LOCATION Include GT subcore in core Include GT subcore in example design	GT_LOCATION 1 0	1
GT_REF_CLK_FREQ 161.1328125 195.3125 201.4160156 257.8125 322.265625	GT_REF_CLK_FREQ 161.1328125 195.3125 201.4160156 257.8125 322.265625	161.1328125
GT_DRP_CLK 10 to 250	GT_DRP_CLK 10 to 250	100
GT_TYPE GTY GTH	GT_TYPE GTY GTH	GTY
GT_GROUP_SELECT (options based of device/ package)	GT_GROUP_SELECT (options based of device/ package)	X0Y0
LANE1_GT_LOC X0Y0 X0Y1 X0Y2 X0Y3	LANE1_GT_LOC X0Y0 X0Y1 X0Y2 X0Y3	
LANE2_GT_LOC X0Y1 X0Y2 X0Y3	LANE2_GT_LOC X0Y1 X0Y2 X0Y3	
LANE3_GT_LOC X0Y2 X0Y3	LANE3_GT_LOC X0Y2 X0Y3	
LANE4_GT_LOC X0Y3	LANE4_GT_LOC X0Y3	
ENABLE_PIPELINE_REG TRUE FALSE	ENABLE_PIPELINE_REG 1 0	0
ADD_GT_CNTRL_STS_PORTS TRUE FALSE	ADD_GT_CNTRL_STS_PORTS 1 0	0

Table 4-5: Vivado IDE Parameter to User Parameter Relationship (Cont'd)

Vivado IDE Parameter/Value <sup>(1)</sup>	User Parameter/Value <sup>(1)</sup>	Default Value
INCLUDE_SHARED_LOGIC Include Shared Logic in core Include Shared Logic in example design	INCLUDE_SHARED_LOGIC 1 0	1
FAST_SIM_MODE TRUE FALSE	FAST_SIM_MODE 1 0	0

**Notes:**

- Parameter values are listed in the table where the Vivado IDE parameter value differs from the user parameter value. Such values are shown in this table as indented below the associated parameter.

## Constraining the Core

This section contains information about constraining the core.

### Required Constraints

The USXGMII IP core is delivered with the Xilinx® XDC constraints file.

### Device, Package, and Speed Grade Selections

The USXGMII IP core is available for all Xilinx® UltraScale and UltraScale+™ devices and transceivers.

### Clock Frequencies

The USXGMII IP core has two clocks. Both clocks are 312.5 MHz. The `clk` provides a clock to the TX and RX AXI4-Stream datapath. This clock must be the user interface clock generated by the GT TXUSRCLK output. The `rx_serdes_clk` is generated by the GTs RX interface as the RXUSRCLK output.

### Clock Management

Not Applicable

### Clock Placement

Not Applicable

## Banking

Not Applicable

## Transceiver Placement

Not Applicable

## I/O Standard and Placement

Not Applicable

---

## Simulation

For comprehensive information about Vivado simulation components, as well as information about using supported third-party tools, see the *Vivado Design Suite User Guide: Logic Simulation* (UG900) [Ref 6].

## Simulation Speed Up

The example design contains wait timers. A ``define SIM_SPEED_UP` is available to improve simulation time by speeding up these wait times.

### VCS

Use the vlogan option: `+define+SIM_SPEED_UP`

### ModelSim

Use the vlog option: `+define+SIM_SPEED_UP`

### IES

Use the ncvlog option: `+define+SIM_SPEED_UP`

### Vivado Simulator

Use the xvlog option: `-d SIM_SPEED_UP`

---

## Synthesis and Implementation

For details about synthesis and implementation, see the *Vivado Design Suite User Guide: Designing with IP* (UG896) [\[Ref 3\]](#).

## Example Design

This chapter contains information about the example design provided in the Vivado<sup>®</sup> Design Suite when using the Vivado Integrated Design Environment (IDE).

---

### Overview

Figure 5-1 shows the instantiation of various modules and their hierarchy for a single core configuration of `usxgmi_i_0` example design when the GT (serial transceiver) is inside the IP core.

Sync registers and pipeline registers are used for to synchronize the data between the core and the GT. Clocking helper blocks are used to generate the required clock frequency for the core.



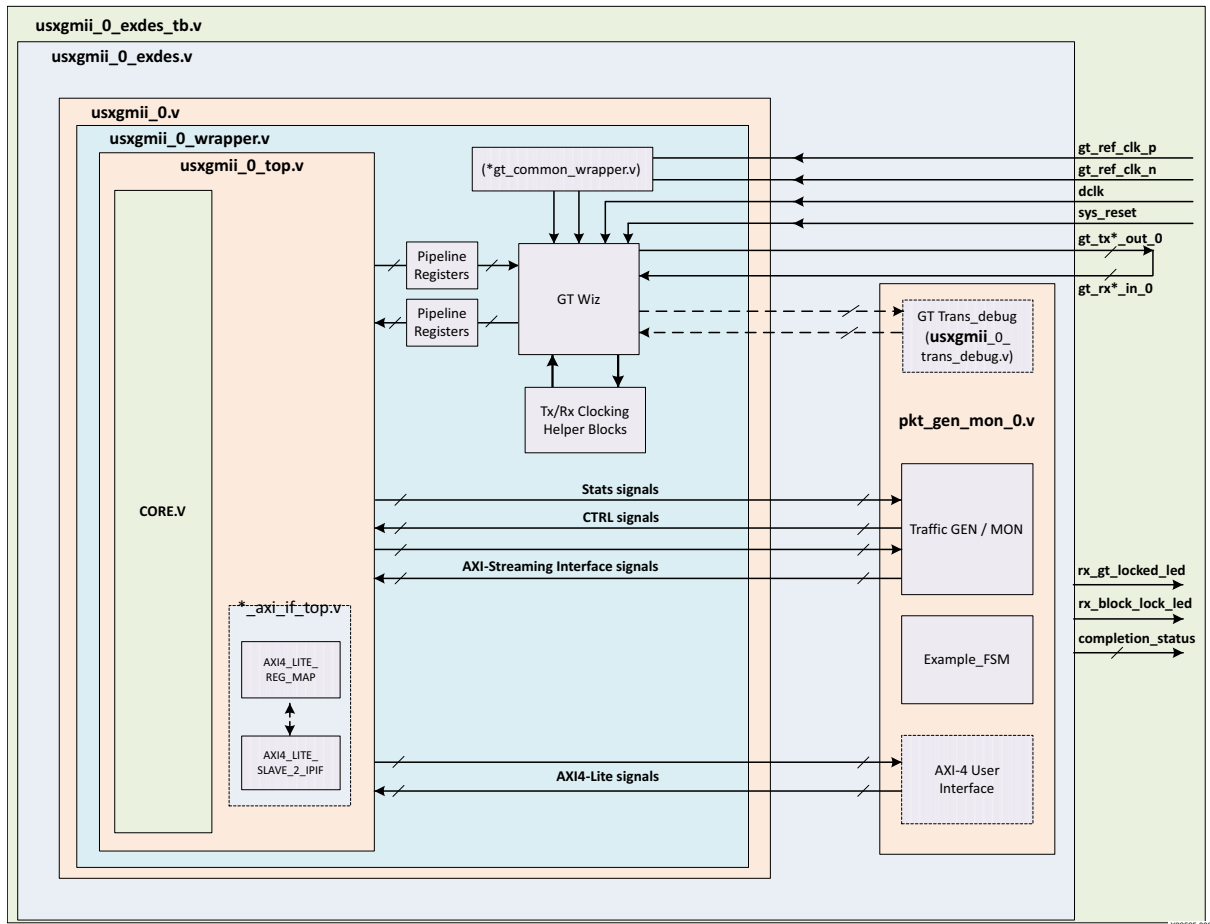

Figure 5-1: Single Core Example Design Hierarchy

AXI4-Stream is available for datapath interface and AXI4-Lite is available for control and statistics interface.

The `usxgmii_0_pkt_gen_mon` module is used to generate the data packets for sanity testing. The packet generation and checking is controlled by an FSM module.

The Example Design consists of these optional modules:

- `usxgmii_0_trans_debug`: This module is present in the example design when you enable the **Additional GT Control and Status Ports** check box from the GT Selection and Configuration tab in Vivado IDE. This module brings out all the GT channel dynamic reconfiguration port (DRP) ports, and some control and status ports of the transceiver module out of the USXGMII core.
- Retiming registers: When you select the **Enable Retiming Register** option from the GT Selection and Configuration tab, it includes a single stage pipeline register between the core and the GT to ease timing, using the `gt_txusrclk2` and `gt_rxusrclk2` for TX and RX paths respectively. However, by default two-stage registering is done for the signals between the GT and the core.

Figure 5-2 shows the instantiation of various modules and their hierarchy for the multiple core configuration of the usxgmii\_0 example design.

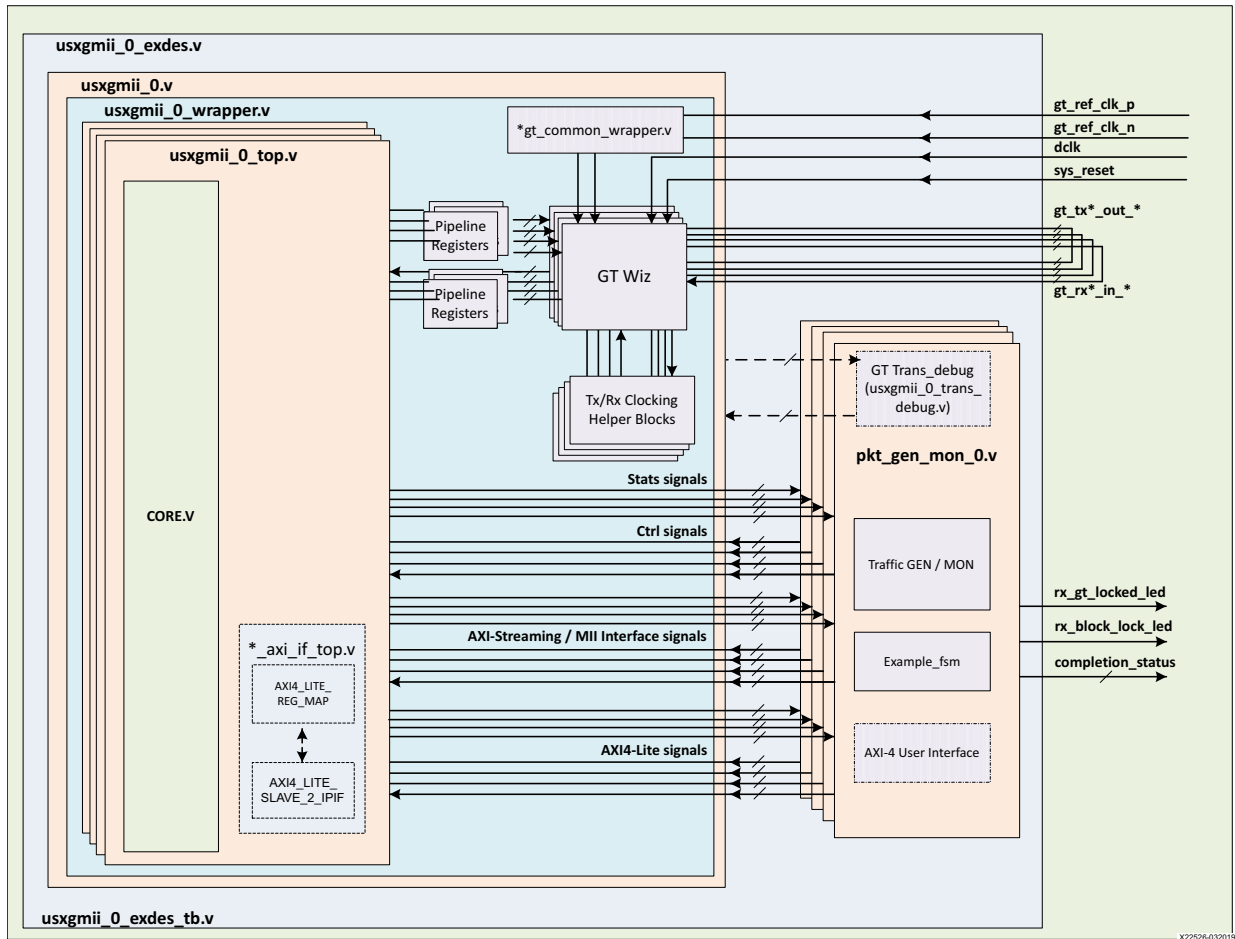

Figure 5-2: Multiple Core Example Design Hierarchy

# Example Design Hierarchy (GT in Example Design)

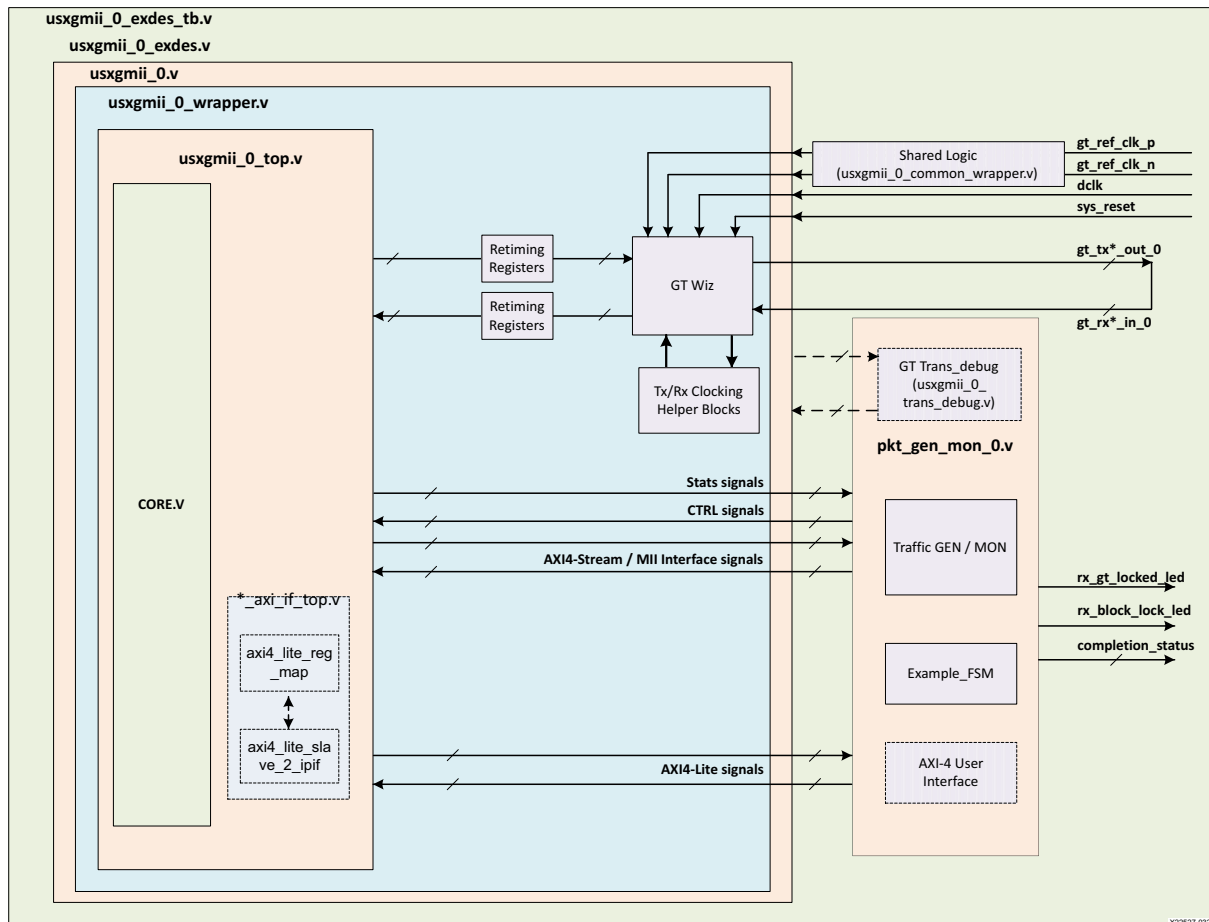

Figure 5-3: Single Core with GT in Example Design Hierarchy

Figure 5-3 shows the instantiation of various modules and their hierarchy for a single core configuration of the usxgmii\_0 example design when the GT (serial transceiver) is outside the core, that is, it is in the example design. This hierarchical example design is delivered when you select the **Include GT subcore in example design** option from the GT Selection and Configuration tab.

The usxgmii\_0\_core\_support.v is present in the hierarchy when you select the **Include GT subcore in example design** option from the GT Selection and Configuration tab or the **Include Shared Logic in example design** option from the Shared Logic tab. This instantiates the usxgmii\_0\_sharedlogic\_wrapper.v module and the usxgmii\_0.v module for the **Include Shared Logic in example design** option. The usxgmii\_0\_gt\_wrapper.v module will be present when you select the **GT subcore in example design** option.

The user interface available is the same as mentioned in the [Overview](#).

The `usxgmii_0.v` module instantiates the necessary the sync registers/retiming pipeline registers for the synchronization of data between the core and the GT.

The `usxgmii_0_pkt_gen_mon` module is used to generate the data packets for sanity testing. The packet generation and checking is controlled by a Finite State Machine (FSM) module.

Description of optional modules are as follows:

- `usxgmii_0_sharedlogic_wrapper`  
This module is present in the example design when you select the **Include GT subcore in example design** option from the GT Selection and Configuration tab or **Include Shared Logic in the Example Design** from the Shared Logic tab. This module brings all modules that can be shared between multiple IP cores and designs outside the core.
- `usxgmii_0_gt_wrapper`  
This module is present in the example design when you select the **Include GT subcore in example design** option from the GT Selection and Configuration tab. This module has instantiations of the GT along with various helper blocks. The clocking helper blocks are used to generate the required clock frequency for the core.

Figure 5-4 shows the instantiation of various modules and their hierarchy for the multiple core configuration of the `usxgmii_0` example design when the GT is in the example design.

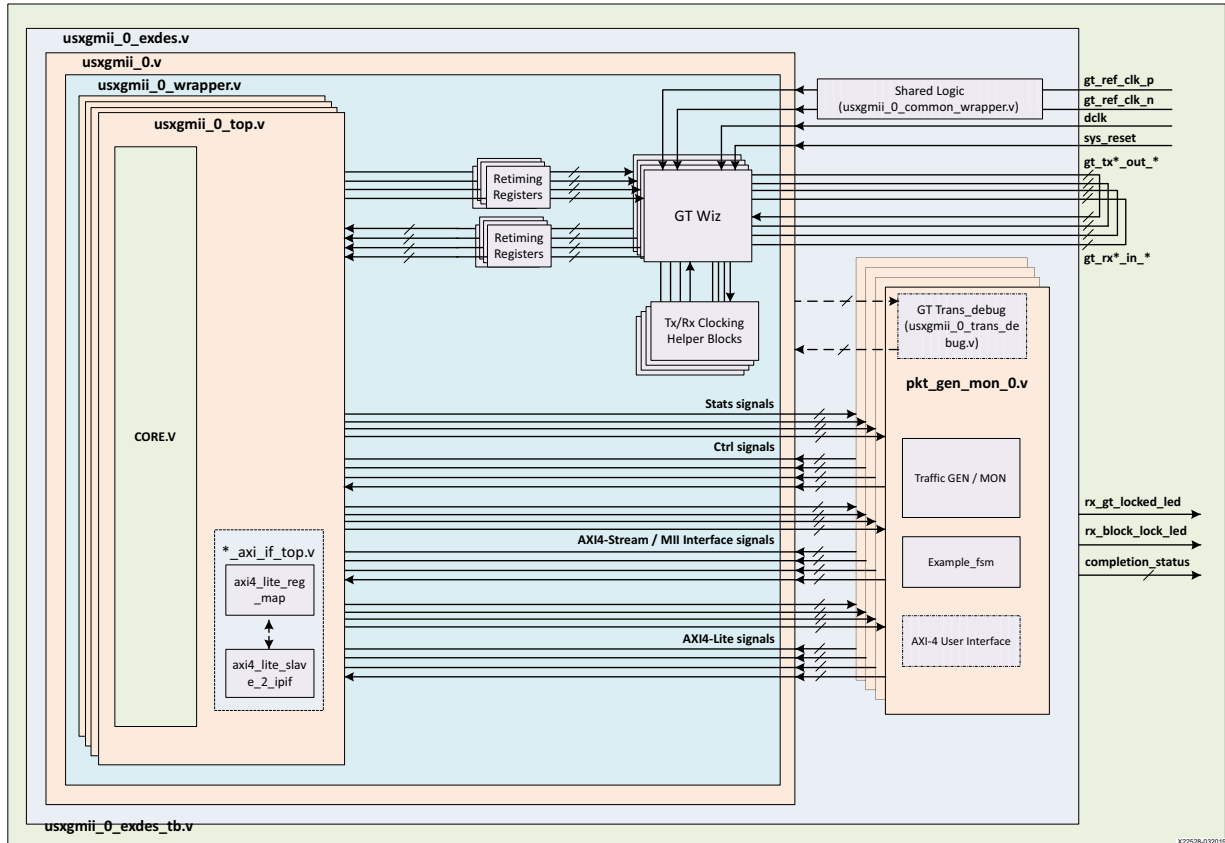

Figure 5-4: Multiple Core with GT in Example Design Hierarchy

## User Interface

General purpose I/Os (GPIOs) are provided to control the example design. The user input and user output ports are described in [Table 5-1](#).

**Table 5-1: User Input and User Output Ports**

Name	Direction	Description
sys_reset	Input	Reset for USXGMII core
gt_ref_clk_p	Input	Differential input clk to GT.
gt_ref_clk_n	Input	Differential input clk to GT.
dclk	Input	Stable/free running input clk to GT.
rx_gt_locked_led_0	Output	Indicates that GT has been locked.
rx_block_lock_led_0	Output	Indicates RX block lock has been achieved.
restart_tx_rx_0	Input	This signal is used to restart the packet generation and reception or the data sanity test when the packet generator and the packet monitor are in idle state.
completion_status	Output	This signal represents the test status/result. 5'd0 Test did not run. 5'd1 - PASSED 25GE/10GE CORE TEST SUCCESSFULLY COMPLETED 5'd2 - No block lock on any lanes. 5'd3 - Not all lanes achieved block lock. 5'd4 - Some lanes lost block lock after achieving block lock. 5'd5 - No lane sync on any lanes. 5'd6 - Not all lanes achieved sync. 5'd7 - Some lanes lost sync after achieving sync. 5'd8 - No alignment status or rx_status was achieved. 5'd9 - Loss of alignment status or rx_status after both were achieved. 5'd10 - TX timed out. 5'd11 - No TX data was sent. 5'd12 - Number of packets received did not equal the number of packets sent. 5'd13 - Total number of bytes received did not equal the total number of bytes sent. 5'd14 - A protocol error was detected. 5'd15 - Bit errors were detected in the received packets. 5'd31 - Test is stuck in reset.

---

## Shared Logic Implementation

Shared logic includes all the shareable modules that can be present as part of the core or in the Example Design.

By default GT common, reset logic and clocking modules are present inside the IP core. In case of the following conditions, these modules will be placed outside the core so that they can be shared with other designs.

- When you select the **Include GT subcore in example design** option in the GT Selection and Configuration tab.
- When you select the **Include Shared Logic in Example Design** option in the Shared Logic tab.

When the shared logic in the example design is selected, a new `usxgmii*_core_support.v` module will be instantiated between the `usxgmii*_exdes.v` and DUT (that is, `usxgmii*_v`). This module will have all the submodules that can be shared between multiple designs.

Figure 5-5 shows the implementation when shared logic is instantiated in the example design for single core.

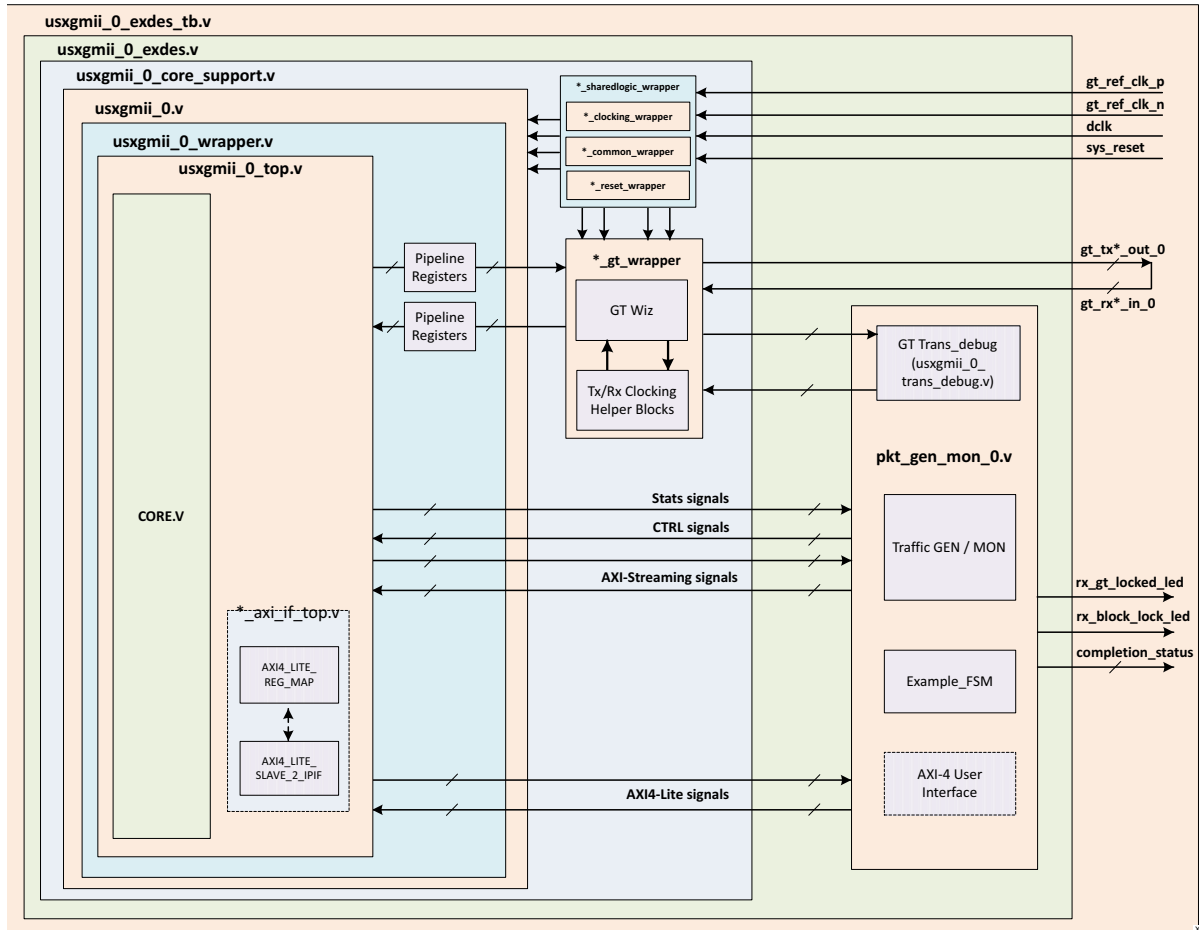

Figure 5-5: Single Core Example Design Hierarchy with Shared Logic Implementation

Figure 5-6 shows the implementation when shared logic is instantiated in the example design for multiple cores.



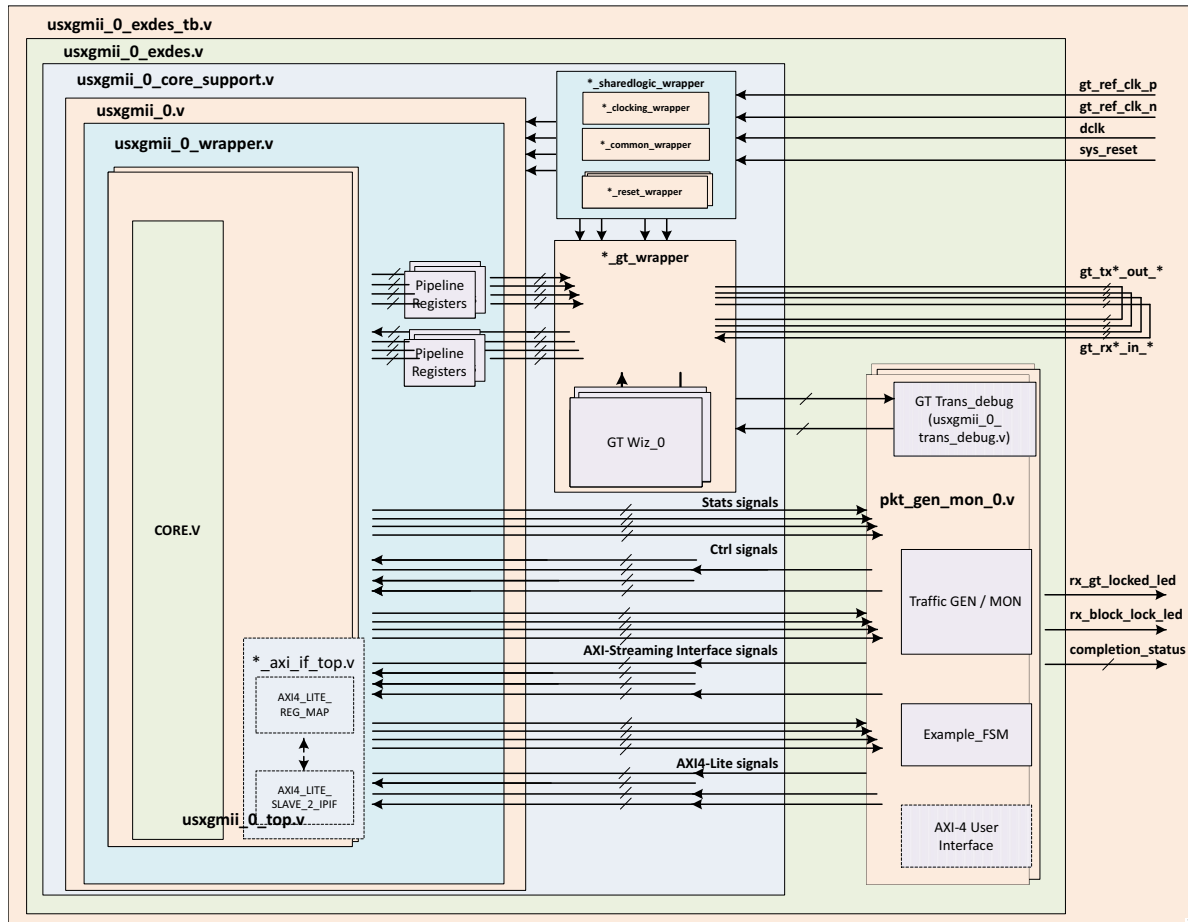

Figure 5-6: Multiple Core Example Design Hierarchy with Shared Logic Implementation

These modules are part of the shared logic wrapper:

- \*\_clocking\_wrapper  
This module contains all the clocking resources that can be shared with other core instances.
- \*\_common\_wrapper  
This module contains the GT common module that can be shared with other core instances.
- \*\_reset\_wrapper  
This module contains the reset logic for the specified configuration.

---

## AXI4-Lite Interface Implementation

In order to instantiate the AXI4-Lite interface to access the control and status registers of the usxgmii core, enable the **Include AXI4-Lite** check box in the Configuration Tab of the Vivado IDE. This option enables the `usxgmii_0_axi_if_top` module (which contains `usxgmii_0_pif_registers` with the `usxgmii_0_slave_2_ipif` module). You can access the AXI4-Lite interface logic registers (control, status and statistics) from the `usxgmii_0_pkt_gen_mon` module.

This mode enables the following features:

- You can configure all the control (CTL) ports of the core through the AXI4-Lite interface. This operation is performed by writing to a set of address locations with the required data to the register map interface.
- You can access all the status and statistics registers from the core through the AXI4-Lite interface. This operation is performed by reading the address locations for the status and statistics registers through register map.

### AXI4 Interface User Logic

The following sections provide the AXI4-Lite interface state machine control and ports.

#### User State Machine

The read and write through the AXI4-Lite slave module interface is controlled by a state machine as shown in [Figure 5-7](#).

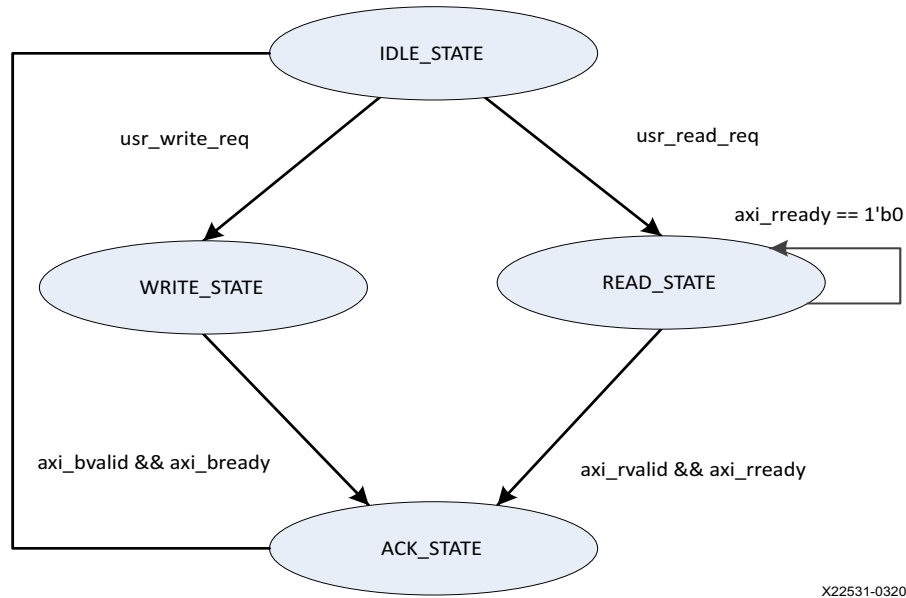

Figure 5-7: User State Machine for AXI4-Lite Interface

Following is a functional description of each state.

- **IDLE\_STATE:** By default the FSM will be in IDLE\_STATE. When the `user_read_req` signal becomes High, then it moves to the READ\_STATE else if the `user_write_req` signal is High, it moves to WRITE\_STATE else it remains in IDLE\_STATE.
- **WRITE\_STATE:** You provide `S_AXI_AWVALID`, `S_AXI_AWADDR`, `S_AXI_WVALID`, `S_AXI_WDATA` and `S_AXI_WSTRB` in this state to write to the register map through AXI. When `S_AXI_BVALID` and `S_AXI_BREADY` from the AXI slave are High, it moves to ACK\_STATE. If any write operation happens in any illegal addresses, the `S_AXI_BRESP [1:0]` signal indicates 2'b10 that asserts the write error signal.
- **READ\_STATE:** You provide `S_AXI_ARVALID` and `S_AXI_ARADDR` in this state to read from the register map through AXI. When `S_AXI_RVALID` and `S_AXI_RREADY` are High then it moves to ACK\_STATE. If any read operation happens from any illegal addresses, the `S_AXI_RRESP [1:0]` signal indicates 2'b10 that asserts the read error signal.
- **ACK\_STATE:** The state moves to IDLE\_STATE.

Table 5-2: AXI User Interface Ports

Name	Size	Direction	Description
S_AXI_ACLK	1	Input	AXI clock signal
S_AXI_ARESETN	1	Input	AXI active-Low synchronous reset
S_AXI_PM_TICK	1	Input	PM tick user input
S_AXI_AWADDR	32	Input	AXI write address
S_AXI_AWVALID	1	Input	AXI write address valid
S_AXI_AWREADY	1	Output	AXI write address ready
S_AXI_WDATA	32	Input	AXI write data
S_AXI_WSTRB	4	Input	AXI write strobe. This signal indicates which byte lanes hold valid data.
S_AXI_WVALID	1	Input	AXI write data valid. This signal indicates that valid write data and strobes are available.
S_AXI_WREADY	1	Output	AXI write data ready
S_AXI_BRESP	2	Output	AXI write response. This signal indicates the status of the write transaction. 'b00 = OKAY 'b01 = EXOKAY 'b10 = SLVERR 'b11 = DECERR
S_AXI_BVALID	1	Output	AXI write response valid. This signal indicates that the channel is signaling a valid write response.
S_AXI_BREADY	1	Input	AXI write response ready.
S_AXI_ARADDR	32	Input	AXI read address
S_AXI_ARVALID	1	Input	AXI read address valid
S_AXI_ARREADY	1	Output	AXI read address ready
S_AXI_RDATA	32	Output	AXI read data issued by slave
S_AXI_RRESP	2	Output	AXI read response. This signal indicates the status of the read transfer. 'b00 = OKAY 'b01 = EXOKAY 'b10 = SLVERR 'b11 = DECERR
S_AXI_RVALID	1	Output	AXI read data valid
S_AXI_RREADY	1	Input	AXI read ready. This signal indicates the user/master can accept the read data and response information.

## Valid Write Transactions

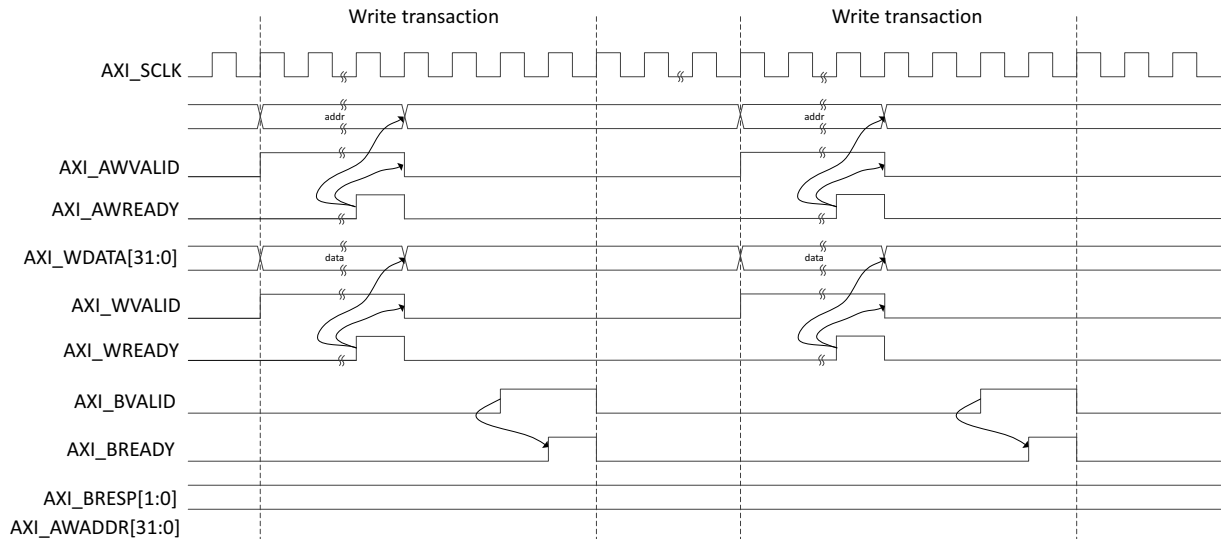

Figure 5-8: AXI4-Lite User Side Write Transaction

## Invalid Write Transactions

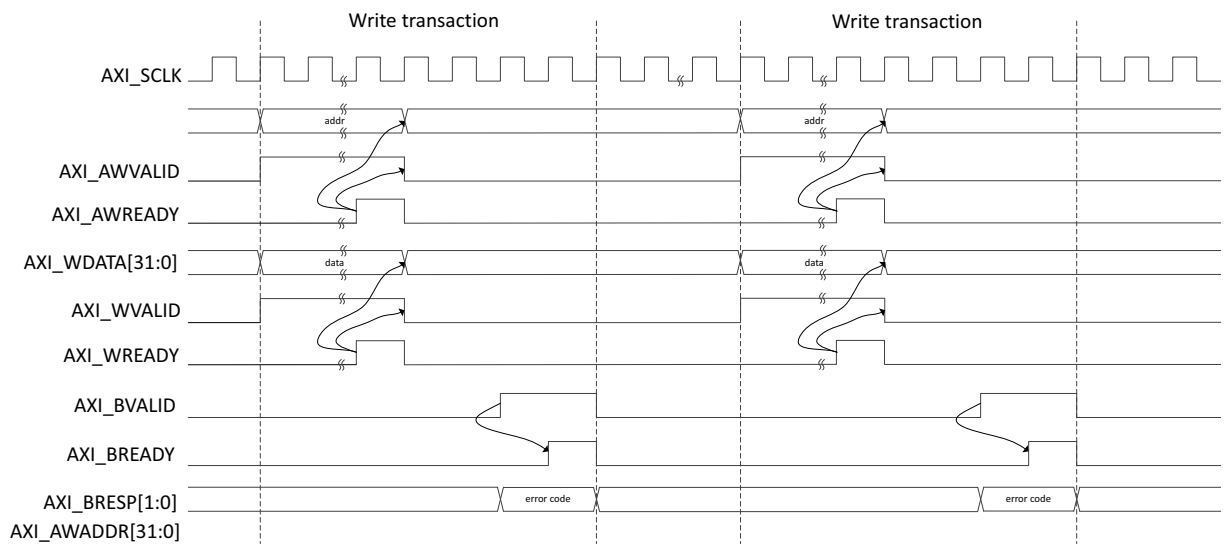

Figure 5-9: AXI4-Lite User Side Write Transaction with Invalid Write Address

## Valid Read Transactions

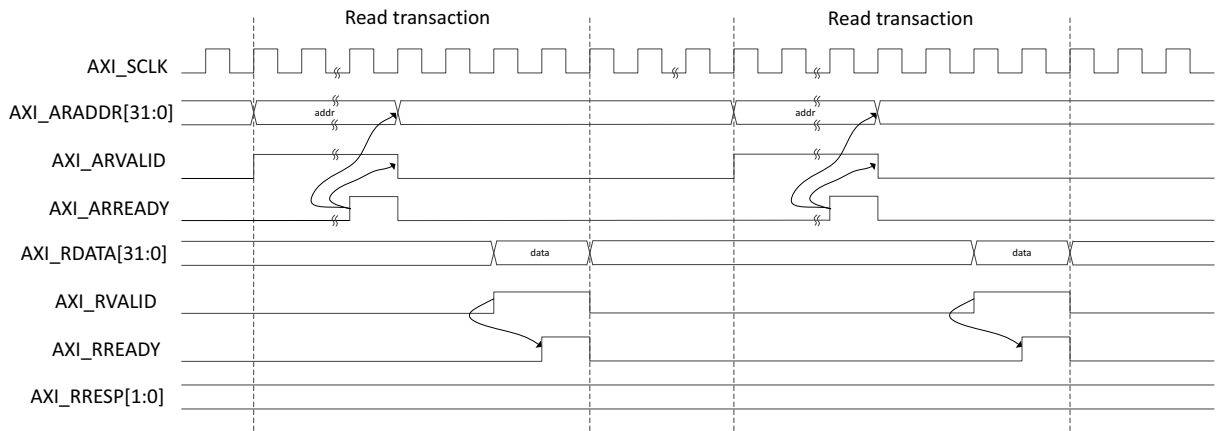

Figure 5-10: AXI4-Lite User Side Read Transaction

## Invalid Read Transactions

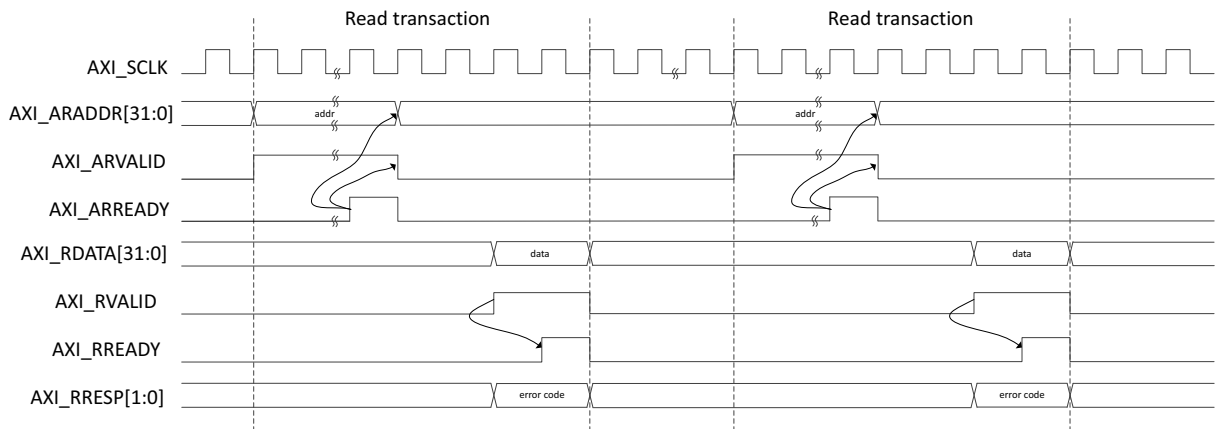
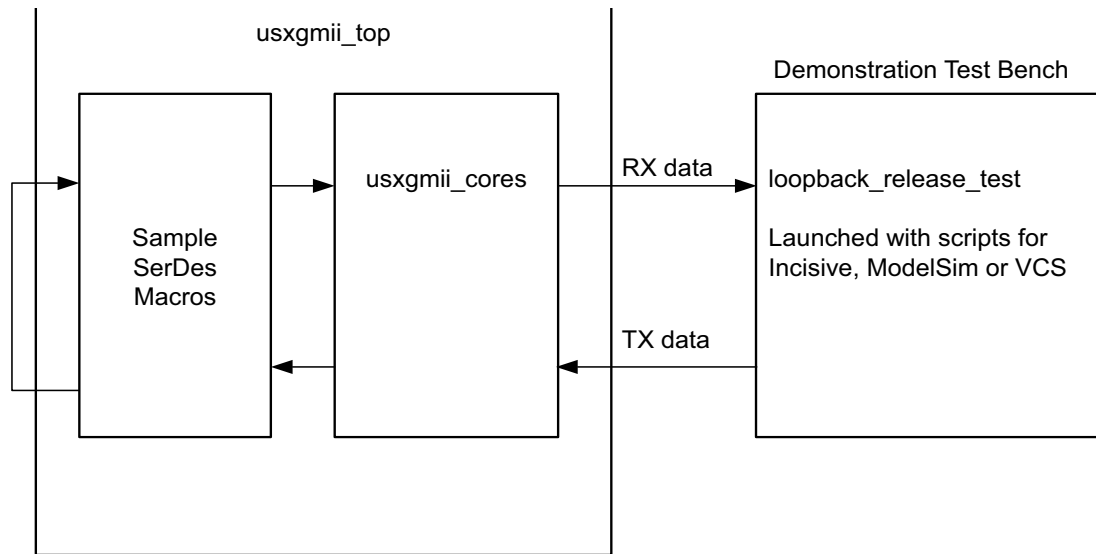

Figure 5-11: User State Machine for AXI4-Lite Interface

# Test Bench

The USXGMII IP core delivery contains a simple example test bench tested against common third-party simulation tools.

Each release includes a demonstration test bench that performs a loopback test on the complete core. For convenience, scripts are provided to launch the test bench from several popular simulators. The test program exercises the datapath to check that the transmitted frames are received correctly. RTL simulation models for the core are included. You must provide the correct path for the transceiver simulation model according to the latest simulation environment settings in your version of the Vivado® Design Suite.



X18960-032717

Test Bench

Figure 6-1: Test Bench

# Verification, Compliance, and Interoperability

The USXGMII core has been designed to the requirements of the EDCS 1467841-NBASE-T USXGMII: Copper PHY ERS specification, revision 1.4.

---

## Simulation

This USXGMII core has been thoroughly tested using a constrained random test environment that verifies the correct operation of each feature of the core.

---

## Hardware Testing

This core is tested in Xilinx silicon for each major increment in functionality.



# Upgrading

This appendix is not applicable for the first release of the core.

# Debugging

This appendix includes details about resources available on the Xilinx Support website and debugging tools.

---

## Finding Help on Xilinx.com

To help in the design and debug process when using the USXGMII core, the [Xilinx Support web page](#) contains key resources such as product documentation, release notes, answer records, information about known issues, and links for obtaining further product support.

### Documentation

This product guide is the main document associated with the USXGMII core. This guide, along with documentation related to all products that aid in the design process, can be found on the [Xilinx Support web page](#) or by using the Xilinx<sup>®</sup> Documentation Navigator.

Download the Xilinx Documentation Navigator from the [Downloads page](#). For more information about this tool and the features available, open the online help after installation.

### Answer Records

Answer Records include information about commonly encountered problems, helpful information on how to resolve these problems, and any known issues with a Xilinx product. Answer Records are created and maintained daily ensuring that users have access to the most accurate information available.

Answer Records for this core can be located by using the Search Support box on the main [Xilinx support web page](#). To maximize your search results, use proper keywords such as

- Product name
- Tool message(s)
- Summary of the issue encountered

A filter search is available after results are returned to further target the results.

## Master Answer Record for the USXGMII core

AR: [69866](#)

## Technical Support

Xilinx provides technical support at the [Xilinx Support web page](#) for this LogiCORE™ IP product when used as described in the product documentation. Xilinx cannot guarantee timing, functionality, or support if you do any of the following:

- Implement the solution in devices that are not defined in the documentation.
- Customize the solution beyond that allowed in the product documentation.
- Change any section of the design labeled DO NOT MODIFY.

To contact Xilinx Technical Support, navigate to the [Xilinx Support web page](#).

---

## Debug Tools

There are many tools available to address USXGMII design issues. It is important to know which tools are useful for debugging various situations.

### Vivado Design Suite Debug Feature

The Vivado® Design Suite debug feature inserts logic analyzer and virtual I/O cores directly into your design. The debug feature also allows you to set trigger conditions to capture application and integrated block port signals in hardware. Captured signals can then be analyzed. This feature in the Vivado IDE is used for logic debugging and validation of a design running in Xilinx devices.

The Vivado logic analyzer is used with the logic debug IP cores, including:

- ILA 2.0 (and later versions)
- VIO 2.0 (and later versions)

See the *Vivado Design Suite User Guide: Programming and Debugging* (UG908) [\[Ref 7\]](#).

# Additional Resources and Legal Notices

---

## Xilinx Resources

For support resources such as Answers, Documentation, Downloads, and Forums, see [Xilinx Support](#).

---

## Documentation Navigator and Design Hubs

Xilinx<sup>®</sup> Documentation Navigator provides access to Xilinx documents, videos, and support resources, which you can filter and search to find information. To open the Xilinx Documentation Navigator (DocNav):

- From the Vivado<sup>®</sup> IDE, select **Help > Documentation and Tutorials**.
- On Windows, select **Start > All Programs > Xilinx Design Tools > DocNav**.
- At the Linux command prompt, enter `docnav`.

Xilinx<sup>®</sup> Design Hubs provide links to documentation organized by design tasks and other topics, which you can use to learn key concepts and address frequently asked questions. To access the Design Hubs:

- In the Xilinx Documentation Navigator, click the **Design Hubs View** tab.
- On the Xilinx website, see the [Design Hubs](#) page.

**Note:** For more information on Documentation Navigator, see the [Documentation Navigator](#) page on the Xilinx website.

## References

These documents provide supplemental material useful with this product guide:

1. *IEEE Standard for Ethernet* ([IEEE Std 802.3-2014](#))
2. *Vivado Design Suite User Guide: Designing IP Subsystems using IP Integrator* ([UG994](#))
3. *Vivado Design Suite User Guide: Designing with IP* ([UG896](#))
4. USXGMII specification EDCS-1467841 revision 1.4  
**Note:** Xilinx recommends that you join the NBASE-T Alliance to gain access to the USXGMII specification. For more information on membership, visit the [NBASE-T Alliance website](#).
5. *Vivado Design Suite User Guide: Getting Started* ([UG910](#))
6. *Vivado Design Suite User Guide: Logic Simulation* ([UG900](#))
7. *Vivado Design Suite User Guide: Programming and Debugging* ([UG908](#))
8. *UltraScale Architecture GTY Transceivers User Guide* ([UG578](#))

## Revision History

The following table shows the revision history for this document.

Date	Version	Revision
06/26/2020	1.1	Updated Table 2-1.
04/24/2019	1.1	Updated Figures 4-1, 4-2, 4-3, and 4-4. Updated Tables 2-7, 2-26, 4-1, and 4-5.
10/04/2017	1.0	Initial public release. The document title has been changed from <i>USXGMII LogiCORE IP Product Guide</i> to <i>USXGMII Ethernet Subsystem Product Guide</i> .

## Please Read: Important Legal Notices

The information disclosed to you hereunder (the "Materials") is provided solely for the selection and use of Xilinx products. To the maximum extent permitted by applicable law: (1) Materials are made available "AS IS" and with all faults, Xilinx hereby DISCLAIMS ALL WARRANTIES AND CONDITIONS, EXPRESS, IMPLIED, OR STATUTORY, INCLUDING BUT NOT LIMITED TO WARRANTIES OF MERCHANTABILITY, NON-INFRINGEMENT, OR FITNESS FOR ANY PARTICULAR PURPOSE; and (2) Xilinx shall not be liable (whether in contract or tort, including negligence, or under any other theory of liability) for any loss or damage of any kind or nature related to, arising under, or in connection with, the Materials (including your use of the Materials), including for any direct, indirect, special, incidental, or consequential loss or damage (including loss of data, profits, goodwill, or any type of loss or damage suffered as a result of any action brought by a third party) even if such damage or loss was reasonably foreseeable or Xilinx had been advised of the possibility of the same. Xilinx assumes no obligation to correct any errors contained in the Materials or to notify you of updates to the Materials or to product specifications. You may not reproduce, modify, distribute, or publicly display the Materials without prior written consent. Certain products are subject to the terms and conditions of Xilinx's limited warranty, please refer to Xilinx's Terms of Sale which can be viewed at <https://www.xilinx.com/legal.htm#tos>; IP cores may be subject to warranty and support terms contained in a license issued to you by Xilinx. Xilinx products are not designed or intended to be fail-safe or for use in any application requiring fail-safe performance; you assume sole risk and liability for use of Xilinx products in such critical applications, please refer to Xilinx's Terms of Sale which can be viewed at <https://www.xilinx.com/legal.htm#tos>.

### **AUTOMOTIVE APPLICATIONS DISCLAIMER**

AUTOMOTIVE PRODUCTS (IDENTIFIED AS "XA" IN THE PART NUMBER) ARE NOT WARRANTED FOR USE IN THE DEPLOYMENT OF AIRBAGS OR FOR USE IN APPLICATIONS THAT AFFECT CONTROL OF A VEHICLE ("SAFETY APPLICATION") UNLESS THERE IS A SAFETY CONCEPT OR REDUNDANCY FEATURE CONSISTENT WITH THE ISO 26262 AUTOMOTIVE SAFETY STANDARD ("SAFETY DESIGN"). CUSTOMER SHALL, PRIOR TO USING OR DISTRIBUTING ANY SYSTEMS THAT INCORPORATE PRODUCTS, THOROUGHLY TEST SUCH SYSTEMS FOR SAFETY PURPOSES. USE OF PRODUCTS IN A SAFETY APPLICATION WITHOUT A SAFETY DESIGN IS FULLY AT THE RISK OF CUSTOMER, SUBJECT ONLY TO APPLICABLE LAWS AND REGULATIONS GOVERNING LIMITATIONS ON PRODUCT LIABILITY.

© Copyright 2017-2020 Xilinx, Inc. Xilinx, the Xilinx logo, Artix, ISE, Kintex, Spartan, Virtex, Vivado, Zynq, and other designated brands included herein are trademarks of Xilinx in the United States and other countries. All other trademarks are the property of their respective owners.