

Zynq-7000 SoC Technical Reference Manual

UG585 (v1.13) April 2, 2021



Revision History

The following table shows the revision history for this document.

| Date | Version | Revision |
|------------|---------|--|
| 04/08/2012 | 1.0 | Xilinx initial release. |
| 06/25/2012 | 1.1 | Removed Chapter 30, Board Design (now part of UG933, <i>Zynq-7000 SoC PCB Design and Pin Planning Guide</i>). |
| 08/08/2012 | 1.2 | <p>Added information about the 7z010 CLG225 device and references to section 2.5.4 MIO-at-a-Glance Table throughout document. Added section headings 1.1.1 Block Diagram and 1.1.2 Documentation Resources, added sections 1.1.3 Notices and TrustZone Capabilities, and clarified PS MIO I/Os in Chapter 1. Updated Table 2-1. Changed 2.4.2 MIO-EMIO Connections heading to 2.5.2 IOP Interface Connections and clarified first paragraph. Updated Table 2-4. Added section 2.7.1 Clocks and Resets and Table 2-7, and updated Table 2-13 PS MIO I/Os in Chapter 2. Added note under Branch Prediction and Table 3-8 in Chapter 3. Updated Table 4-1 in Chapter 4. Added section 5.1.7 Read/Write Request Capability in Chapter 5. Updated NAND Boot MIO pin assignments and Table 6-6 in Chapter 6. Updated section 7.1.5 CPU Interrupt Signal Pass-through in Chapter 7. Added section heading 10.1.1 Features and added section 10.1.3 Notices in Chapter 10. Updated Parallel (SRAM/NOR) Interface features list and added section 11.1.3 Notices in Chapter 11. Reorganized, clarified, and expanded Chapter 12 to include programming models (added sections 12.1.4 Notices, 12.3 Programming Guide, and 12.5.2 MIO Programming). Added last note in section 13.3.4 Using ADMA in Chapter 13. Added Restrictions in Chapter 14. Clarified first paragraph, added section 15.1.3 Notices, and clarified Figure 15-7 through Figure 15-17 in Chapter 15. Added section 16.1.4 Notices in Chapter 16. Clarified sections 17.2.5 SPI FIFIs, 17.2.6 SPI Clocks, and 17.2.7 SPI-to-SPI Connection in Chapter 17. Reorganized, clarified, and expanded Chapter 18 to include programming models (added sections 18.1.4 Notices and 18.5.1 MIO Programming).</p> <p>Reorganized, clarified, and expanded Chapter 19 to include programming models (added sections 19.1.3 Notices, 19.3 Programming Guide, and 19.5.1 MIO Programming). Updated Table 22-2 and Table 22-3 in Chapter 22. Added section CPU Clock Divisor Restriction in Chapter 25. Updated Table 26-4 in Chapter 26. Clarified section 27.3 I/O Signals in Chapter 27. Added section 28.1.2 Notices in Chapter 28. Clarified Mapping Summary and updated Table 29-1, Table 29-3, and Table 29-5 in Chapter 29. Added section 30.1.3 Notices in Chapter 30. Updated data sheet references in section A.3.1 Zynq-7000 SoC Documents of Appendix A. Updated register database in sections B.3 Module Summary through B.34 USB Controller (usb) in Appendix B.</p> |

| Date | Version | Revision |
|------------|---------|--|
| 10/30/2012 | 1.3 | <p>Changed product name from Extensible Processing Platform (EPP) to SoC throughout document. Added Table 1-1. Added 2.1.1 Notices, 2.4 PS-PL Voltage Level Shifter Enables, Table 2-2: PS Signal Pins, VREF Source Considerations, updated Table 2-2, and added warning to 2.5.7 MIO Pin Electrical Parameters. Added Initialization of L1 Caches, 3.2.4 Memory Ordering, expanded 3.2.5 Memory Management Unit (MMU), added Cache Lockdown by Way Sequence and 3.9 CPU Initialization Sequence. Added 7z007s and 7z010 Device Notice and expanded Table 4-7. Updated and expanded tables in 6.3.4 Quad-SPI Boot through 6.3.13 Post BootROM State, reworked 6.3.6 Debug Status, and added 6.3.13 Post BootROM State and AXI and DMA Done Status Interrupts. Reworked Table 7-4. Added 8.1.2 Notices, Interrupt to PS Interrupt Controller, and Reset. Reorganized and expanded Chapter 9, DMA Controller. Added 10.1.3 Notices, expanded 10.1.6 I/O Signals, added 10.6.12 DRAM Write Latency Restriction, 10.8.1 ECC Initialization, 10.8.4 ECC Programming Model, and 10.9.1 Operating Modes. Added 12.2.4 I/O Mode Considerations and updated 12.3.5 Rx/Tx FIFO Response to I/O Command Sequences. Reworked 16.3.3 I/O Configuration, added 16.4 IEEE 1588 Timestamping and 16.6.6 MIO Pin Considerations. Added 18.2.7 CAN0-to-CAN1 Connection. Expanded 19.1 Introduction, 19.1.3 Notices, and Table 19-1. Added Receiver Timeout Mechanism, updated Figure 19-7. Added 19.2.9 UART0-to-UART1 Connection and 19.2.10 Status and Interrupts, expanded 19.2.11 Modem Control, reworked 19.3 Programming Guide and 19.4.2 Resets. Added 20.2.7 I2C0-to-I2C1 Connection. Added 21.1.2 PL Resources by Device Type, Voltage Level Shifters and reorganized content of Chapter 21. Added 25.7.1 Clock Throttle. Expanded 26.4.1 PL General Purpose User Resets. Updated register database in sections B.3 Module Summary through B.34 USB Controller (usb) in Appendix B.</p> |
| 11/16/2012 | 1.4 | <p>Changed second bullet under NAND Flash Interface from “Up to a 4 GB device” to “Up to a 1 GB device” in Chapter 11.</p> |

| Date | Version | Revision |
|------------|---------|--|
| 03/07/2013 | 1.5 | <p>Added 7z100 device and made minor clarifications to Chapter 1. Made minor clarifications to Chapter 2, Chapter 3, Chapter 4, , and Chapter 5. Clarified section 6.1 Introduction and other sections, and added PS Independent JTAG Non-Secure Boot section in Chapter 6, Boot and Configuration. Made minor clarifications to Chapter 7, Interrupts, Chapter 8, Timers, Chapter 9, DMA Controller, Chapter 10, DDR Memory Controller, Chapter 11, Static Memory Controller, and Chapter 12, Quad-SPI Flash Controller. Expanded 12.2 Functional Description in Chapter 12, Quad-SPI Flash Controller. Made minor clarifications to Chapter 13, SD/SDIO Controller. Made major clarifications/updates to Chapter 14, General Purpose I/O (GPIO). Reworked and expanded Chapter 15, USB Host, Device, and OTG Controller. Made minor clarifications to Chapter 16, Gigabit Ethernet Controller. Reworked and expanded Chapter 17, SPI Controller. Made minor clarifications to Chapter 18, CAN Controller, and Chapter 19, UART Controller. Made major clarifications/updates to Chapter 20, I2C Controller (added new sections, 20.3 Programmer's Guide, 20.4 System Functions, and 20.5 I/O Interface). Made minor clarifications to Chapter 21, Programmable Logic Description and added new sections 21.1.2 PL Resources by Device Type and 21.1.3 Notices. Made minor clarifications to Chapter 22, Programmable Logic Design Guide and Chapter 23, Programmable Logic Test and Debug. Reworked and expanded Chapter 24, Power Management. Made minor clarifications to Chapter 25, Clocks, Chapter 26, Reset System, Chapter 27, JTAG and DAP Subsystem, Chapter 28, System Test and Debug, and Chapter 29, On-Chip Memory (OCM). Reworked and expanded Chapter 30, XADC Interface. Made minor clarifications to Chapter 31, PCI Express. Reworked and expanded Chapter 32, Device Secure Boot. Updated Appendix A, Additional Resources. Updated register database in sections B.3 Module Summary through B.34 USB Controller (usb) in Appendix B.</p> |

| Date | Version | Revision |
|------------|---------|--|
| 06/28/2013 | 1.6 | <p>Added icons where applicable. Enhanced first sentence under Quad-SPI Controller in c. Clarified first paragraph, added step 2, and clarified step 5 in section 2.4 PS-PL Voltage Level Shifter Enables. Changed “drive strength” to “slew rate” in section 2.5.7 MIO Pin Electrical Parameters. Added second sentence and updated Table 2-11 in section 2.7.4 Idle AXI, DDR Urgent/Arb, SRAM Interrupt Signals. Corrected Note 4 in Table 4-1 and Table 4-2. Made minor clarifications and added new RSA Authentication Time section to Chapter 6, Boot and Configuration. Made minor clarifications to sections 7.2.2 CPU Private Peripheral Interrupts (PPI) and 7.2.3 Shared Peripheral Interrupts (SPI), and updated Table 7-4 and Table 7-5. Clarified first row in Table 9-12. Added tip to section 10.4.3 Aging Counter, added sentence to Write Leveling, and step 2 in section 10.9.2 Changing Clock Frequencies, and moved section 10.9.6 DDR Power Reduction from Chapter 24, Power Management to this chapter. Added tip to section 11.2.2 Clocks. Added Table 12-8. Added MMC3.31 standard information to section 13.1 Introduction. Added step 6 to section 14.3.1 Start-up Sequence, added section 14.3.5 GPIO as Wake-up Event, added second paragraph to 14.4.1 Clocks. Added section 16.7 Known Issues. Added note to 17.4.2 Clocks. Changed value of 107 Mb to 140 Mb in second sentence under section 21.4 Configuration. Added values for the 7z100 device in Table 21-2. Clarified first paragraph in section 24.2.2 PL Power-down Control and updated Table 24-2. Added note to section 25.6.1 USB Clocks, clarified second paragraph in section 25.10.4 PLLs, and added sentence to steps 2 and 3 in Software-Controlled PLL Update section. Changed “RESET_REASON” to “REBOOT_STATUS” in section 26.2.3 System Software Reset, added section 26.5 Register Overview, deleted first two rows from Table 26-2 and modified last paragraph in section 26.5.1 Persistent Registers. Clarified section 29.1 Introduction, added three paragraphs to Starvation Scenarios section, and added 29.2.5 Address Mapping heading. Corrected spelling of “MCTRL” to “MCTL” in sections 30.4 Programming Guide for the PS-XADC Interface and 30.7.2 Resets. Added section 31.5 Root Complex Use Case. Added FIPS standards and clarified section 32.1.2 Features, updated configuration file and secure boot process steps in Figure 32-1, added boot time penalty to Power on Reset section, changed “Secure Boot” heading to “Secure FSBL Decryption”, changed “ROM code” to “OCM ROM Memory” in Figure 32-2 and “ROM” to “OCM ROM” in Table 32-3, updated sections 32.2.7 Boot Image and Bitstream Decryption and Authentication, 32.2.8 HMAC Signature, 32.2.9 AES Key Management, 32.3.1 Non-Secure Boot State, 32.3.4 Boot Partition Search, and 32.3.7 Secure Boot Modes of Operation (deleted Table 32-4, “Non-secure Boot Options”). Updated register database in sections B.3 Module Summary through B.34 USB Controller (usb) in Appendix B.</p> |
| 02/11/2014 | 1.7 | <p>Added 7z015 device, updated device notices, and made minor clarifications throughout document (denoted with change bars). Added section 3.10 Implementation-Defined Configurations. Added sections 5.7 Loopback and 5.8 Exclusive AXI Accesses. Reworked Chapter 6, Boot and Configuration. Added section 7.2.4 Interrupt Sensitivity, Targeting and Handling. Added sections 8.4.6 Clock Input Option for SWDT and 8.5.6 Clock Input Option for Counter/Timer. Updated section 10.7 Register Overview. Added section 11.7 NOR Flash Bandwidth. Added sections AXI Read Command Processing and 12.2.7 Supported Memory Read and Write Commands. Added section 16.1.4 Clock Domains and reworked section 16.7 Known Issues (previously titled “Limitations”). Updated section 21.1.2 PL Resources by Device Type and added section 21.3.4 GTP Low-Power Serial Transceivers. Added Peripheral Clock Gating subsection. Updated Table 26-1 and Table 26-4. Updated register database in sections B.3 Module Summary through B.34 USB Controller (usb) in Appendix B.</p> |

| Date | Version | Revision |
|------------|---------|--|
| 09/16/2014 | 1.8 | Added position information for available device and package combinations for the signals associated with each GT serial transceiver channel to sections 21.3.3 GTX Low-Power Serial Transceivers and 21.3.4 GTP Low-Power Serial Transceivers . |
| 09/19/2014 | 1.8.1 | Removed erroneous banner from Chapter 21, Programmable Logic Description . Corrected <i>send feedback</i> button clarity issue in footers. |
| 11/17/2014 | 1.9 | Added 7z035 device, updated device notices, and made minor clarifications throughout document (denoted with change bars). |
| 11/19/2014 | 1.9.1 | Corrected document date. |
| 02/23/2015 | 1.10 | Added clarification on the timing relationship between PL power up and the PS POR reset signal to section 2.2 Power Pins and section 6.3.3 BootROM Performance: PS_POR_B De-assertion Guidelines . |
| 09/27/2016 | 1.11 | Added 7z007s, 7z012s, and 7z014s single-core devices and updated the respective device notices throughout document (denoted with change bars). Updated Figure 2-1 , Table 21-1 , and Table 21-2 . Updated device codes in Register PSS_IDCODE Details. |
| 10/20/2017 | 1.12 | Made minor clarifications throughout document (denoted with change bars). |
| 12/06/2017 | 1.12.1 | Removed internal review comment from 6-bit Programmable Divider section. |
| 07/01/2018 | 1.12.2 | Editorial updates only. No technical content updates. |
| 04/02/2021 | 1.13 | Removed all sections and mentions of the IEEE 1588 Time Stamp (no longer a feature). Minor updates to 1.2.3 I/O Peripherals , Table 2-13 , Table 3-3 , 3.7.1 Reset Functionality , 6.3 BootROM Code , 6.4.4 PCAP Datapath Configurations , 8.4.3 Functional Description , 10.9.2 Changing Clock Frequencies , 11.1.1 Features , 11.2.6 PL353 Functionality , 12.2.7 Supported Memory Read and Write Commands , 15.1.3 Hardware System Viewpoint , 15.5.4 Endpoint Initialization , 15.15.2 Reset Types , Table 15-50 , 16.1.5 Notices , 16.2 Functional Description and Programming Model , 17.2.6 Interrupt Register Bits, Logic Flow , 20.1.1 Features , 25.10.1 Branch Clock Generator , Table 32-3 , 32.2.4 eFUSE Settings . Removed obsolete reference to Software Programming Documents. Updated Appendix B, Register Details and Register Summary in Appendix B to update bits for SPI, DMA, L2, Cache, CAN, and GEM modules. |

Table of Contents

| | |
|------------------------|---|
| Revision History | 2 |
|------------------------|---|

Chapter 1: Introduction

| | |
|---|-----------|
| 1.1 Overview | 27 |
| 1.1.1 Block Diagram | 28 |
| 1.1.2 Documentation Resources | 29 |
| 1.1.3 Notices | 31 |
| 1.2 Processing System (PS) Features and Descriptions | 32 |
| 1.2.1 Application Processor Unit (APU) | 32 |
| 1.2.2 Memory Interfaces | 33 |
| 1.2.3 I/O Peripherals | 35 |
| 1.3 Programmable Logic Features and Descriptions | 39 |
| 1.4 Interconnect Features and Description | 40 |
| 1.4.1 PS Interconnect Based on AXI High Performance Datapath Switches | 40 |
| 1.4.2 PS-PL Interfaces | 41 |
| 1.5 System Software | 42 |

Chapter 2: Signals, Interfaces, and Pins

| | |
|--|-----------|
| 2.1 Introduction | 43 |
| 2.1.1 Notices | 43 |
| 2.2 Power Pins | 45 |
| 2.3 PS I/O Pins | 46 |
| 2.4 PS-PL Voltage Level Shifter Enables | 47 |
| 2.5 PS-PL MIO-EMIO Signals and Interfaces | 48 |
| 2.5.1 I/O Peripheral (IOP) Interface Routing | 48 |
| 2.5.2 IOP Interface Connections | 49 |
| 2.5.3 MIO Pin Assignment Considerations | 51 |
| 2.5.4 MIO-at-a-Glance Table | 53 |
| 2.5.5 MIO Signal Routing | 54 |
| 2.5.6 Default Logic Levels | 54 |
| 2.5.7 MIO Pin Electrical Parameters | 55 |
| 2.6 PS-PL AXI Interfaces | 56 |
| 2.7 PS-PL Miscellaneous Signals | 56 |
| 2.7.1 Clocks and Resets | 57 |
| 2.7.2 Interrupt Signals | 58 |
| 2.7.3 Event Signals | 58 |
| 2.7.4 Idle AXI, DDR Urgent/Arb, SRAM Interrupt Signals | 58 |
| 2.7.5 DMA Req/Ack Signals | 59 |
| 2.8 PL I/O Pins | 59 |

Chapter 3: Application Processing Unit

| | |
|---|------------|
| 3.1 Introduction | 61 |
| 3.1.1 Basic Functionality | 61 |
| 3.1.2 System-Level View | 63 |
| 3.2 Cortex-A9 Processors | 65 |
| 3.2.1 Summary | 65 |
| 3.2.2 Central Processing Unit (CPU) | 65 |
| 3.2.3 Level 1 Caches | 68 |
| 3.2.4 Memory Ordering | 71 |
| 3.2.5 Memory Management Unit (MMU) | 76 |
| 3.2.6 Interfaces | 89 |
| 3.2.7 NEON | 90 |
| 3.2.8 Performance Monitoring Unit | 91 |
| 3.3 Snoop Control Unit (SCU) | 91 |
| 3.3.1 Summary | 91 |
| 3.3.2 Address Filtering | 92 |
| 3.3.3 SCU Master Ports | 92 |
| 3.4 L2-Cache | 93 |
| 3.4.1 Summary | 93 |
| 3.4.2 Exclusive L2-L1 Cache Configuration | 96 |
| 3.4.3 Cache Replacement Strategy | 97 |
| 3.4.4 Cache Lockdown | 97 |
| 3.4.5 Enabling and Disabling the L2 Cache Controller | 99 |
| 3.4.6 RAM Access Latency Control | 99 |
| 3.4.7 Store Buffer Operation | 99 |
| 3.4.8 Optimizations Between Cortex-A9 and L2 Controller | 100 |
| 3.4.9 Pre-fetching Operation | 102 |
| 3.4.10 Programming Model | 102 |
| 3.5 APU Interfaces | 104 |
| 3.5.1 PL Co-processing Interfaces | 104 |
| 3.5.2 Interrupt Interface | 107 |
| 3.6 Support for TrustZone | 108 |
| 3.7 Application Processing Unit (APU) Reset | 108 |
| 3.7.1 Reset Functionality | 108 |
| 3.7.2 APU State After Reset | 109 |
| 3.8 Power Considerations | 110 |
| 3.8.1 Introduction | 110 |
| 3.8.2 Standby Mode | 110 |
| 3.8.3 Dynamic Clock Gating in the L2 Controller | 111 |
| 3.9 CPU Initialization Sequence | 111 |
| 3.10 Implementation-Defined Configurations | 112 |

Chapter 4: System Addresses

| | |
|--------------------------------------|------------|
| 4.1 Address Map | 113 |
| 4.2 System Bus Masters | 115 |
| 4.3 SLCR Registers | 115 |
| 4.4 CPU Private Bus Registers | 116 |
| 4.5 SMC Memory | 116 |

| | |
|--|-----|
| 4.6 PS I/O Peripherals | 117 |
| 4.7 Miscellaneous PS Registers | 117 |

Chapter 5: Interconnect

| | |
|--|------------|
| 5.1 Introduction | 119 |
| 5.1.1 Features | 119 |
| 5.1.2 Block Diagram | 120 |
| 5.1.3 Datapaths | 122 |
| 5.1.4 Clock Domains | 123 |
| 5.1.5 Connectivity | 126 |
| 5.1.6 AXI ID | 126 |
| 5.1.7 Read/Write Request Capability | 127 |
| 5.1.8 Register Overview | 127 |
| 5.2 Quality of Service (QoS) | 128 |
| 5.2.1 Basic Arbitration | 128 |
| 5.2.2 Advanced QoS | 128 |
| 5.2.3 DDR Port Arbitration | 129 |
| 5.3 AXI_HP Interfaces | 129 |
| 5.3.1 Features | 129 |
| 5.3.2 Block Diagram | 130 |
| 5.3.3 Functional Description | 131 |
| 5.3.4 Performance | 131 |
| 5.3.5 Register Overview | 132 |
| 5.3.6 Bandwidth Management Features | 132 |
| 5.3.7 Transaction Types | 136 |
| 5.3.8 Command Interleaving and Re-Ordering | 136 |
| 5.3.9 Performance Optimization Summary | 137 |
| 5.4 AXI_ACP Interface | 138 |
| 5.5 AXI_GP Interfaces | 139 |
| 5.5.1 Features | 139 |
| 5.5.2 Performance | 139 |
| 5.6 PS-PL AXI Interface Signals | 139 |
| 5.6.1 AXI Signals | 139 |
| 5.6.2 AXI Clocks and Resets | 143 |
| 5.7 Loopback | 144 |
| 5.8 Exclusive AXI Accesses | 145 |
| 5.8.1 CPU/L2 | 145 |
| 5.8.2 ACP | 146 |
| 5.8.3 DDRC | 146 |
| 5.8.4 System Summary | 148 |

Chapter 6: Boot and Configuration

| | |
|--|------------|
| 6.1 Introduction | 149 |
| 6.1.1 PS Hardware Boot Stages | 153 |
| 6.1.2 PS Software Boot Stages | 153 |
| 6.1.3 Boot Device Content | 154 |
| 6.1.4 Boot Modes | 154 |
| 6.1.5 BootROM Execution | 155 |
| 6.1.6 FSBL / User Code Execution | 156 |

| | |
|---|------------|
| 6.1.7 PL Boot Process | 157 |
| 6.1.8 PL Configuration Paths | 157 |
| 6.1.9 Device Configuration Interface | 159 |
| 6.1.10 Starting Code on CPU 1 | 161 |
| 6.1.11 Development Environment | 161 |
| 6.2 Device Start-up | 162 |
| 6.2.1 Introduction | 162 |
| 6.2.2 Power Requirements | 162 |
| 6.2.3 Clocks and PLLs | 163 |
| 6.2.4 Reset Operations | 163 |
| 6.2.5 Boot Mode Pin Settings | 166 |
| 6.2.6 I/O Pin Connections for Boot Devices | 167 |
| 6.3 BootROM Code | 168 |
| 6.3.1 BootROM Flowchart | 168 |
| 6.3.2 BootROM Header | 172 |
| 6.3.3 BootROM Performance | 177 |
| 6.3.4 Quad-SPI Boot | 181 |
| 6.3.5 NAND Boot | 184 |
| 6.3.6 NOR Boot | 188 |
| 6.3.7 SD Card Boot | 189 |
| 6.3.8 JTAG Boot | 191 |
| 6.3.9 Reset, Boot, and Lockdown States | 194 |
| 6.3.10 BootROM Header Search | 196 |
| 6.3.11 MultiBoot | 198 |
| 6.3.12 BootROM Error Codes | 199 |
| 6.3.13 Post BootROM State | 203 |
| 6.3.14 Registers Modified by the BootROM – Examples | 205 |
| 6.4 Device Boot and PL Configuration | 207 |
| 6.4.1 PL Control via PS Software | 208 |
| 6.4.2 Boot Sequence Examples | 209 |
| 6.4.3 PCAP Bridge to PL | 213 |
| 6.4.4 PCAP Datapath Configurations | 215 |
| 6.4.5 PL Control via User-JTAG | 219 |
| 6.5 Reference Section | 221 |
| 6.5.1 PL Configuration Considerations | 221 |
| 6.5.2 Boot Time Reference | 222 |
| 6.5.3 Register Overview | 224 |
| 6.5.4 PS Version and Device Revision | 225 |

Chapter 7: Interrupts

| | |
|---|------------|
| 7.1 Environment | 226 |
| 7.1.1 Private, Shared and Software Interrupts | 227 |
| 7.1.2 Generic Interrupt Controller (GIC) | 227 |
| 7.1.3 Resets and Clocks | 227 |
| 7.1.4 Block Diagram | 227 |
| 7.1.5 CPU Interrupt Signal Pass-through | 228 |
| 7.2 Functional Description | 229 |
| 7.2.1 Software Generated Interrupts (SGI) | 229 |
| 7.2.2 CPU Private Peripheral Interrupts (PPI) | 230 |
| 7.2.3 Shared Peripheral Interrupts (SPI) | 230 |
| 7.2.4 Interrupt Sensitivity, Targeting and Handling | 232 |

| | |
|---|------------|
| 7.2.5 Wait for Interrupt Event Signal (WFI) | 234 |
| 7.3 Register Overview | 234 |
| 7.3.1 Write Protection Lock | 235 |
| 7.4 Programming Model | 236 |
| 7.4.1 Interrupt Prioritization | 236 |
| 7.4.2 Interrupt Handling | 236 |
| 7.4.3 Arm Programming Topics | 236 |
| 7.4.4 Legacy Interrupts and Security Extensions | 237 |

Chapter 8: Timers

| | |
|---|------------|
| 8.1 Introduction | 238 |
| 8.1.1 System Diagram | 239 |
| 8.1.2 Notices | 239 |
| 8.2 CPU Private Timers and Watchdog Timers | 240 |
| 8.2.1 Clocking | 240 |
| 8.2.2 Interrupt to PS Interrupt Controller | 240 |
| 8.2.3 Resets | 240 |
| 8.2.4 Register Overview | 240 |
| 8.3 Global Timer (GT) | 241 |
| 8.3.1 Clocking | 241 |
| 8.3.2 Register Overview | 241 |
| 8.4 System Watchdog Timer (SWDT) | 242 |
| 8.4.1 Features | 242 |
| 8.4.2 Block Diagram | 243 |
| 8.4.3 Functional Description | 243 |
| 8.4.4 Register Overview | 244 |
| 8.4.5 Programming Model | 245 |
| 8.4.6 Clock Input Option for SWDT | 245 |
| 8.4.7 Reset Output Option for SWDT | 245 |
| 8.5 Triple Timer Counters (TTC) | 246 |
| 8.5.1 Features | 246 |
| 8.5.2 Block Diagram | 246 |
| 8.5.3 Functional Description | 247 |
| 8.5.4 Register Overview | 248 |
| 8.5.5 Programming Model | 249 |
| 8.5.6 Clock Input Option for Counter/Timer | 250 |
| 8.6 I/O Signals | 251 |

Chapter 9: DMA Controller

| | |
|---|------------|
| 9.1 Introduction | 252 |
| 9.1.1 Features | 253 |
| 9.1.2 System Viewpoint | 254 |
| 9.1.3 Block Diagram | 255 |
| 9.1.4 Notices | 257 |
| 9.2 Functional Description | 258 |
| 9.2.1 DMA Transfers on the AXI Interconnect | 259 |
| 9.2.2 AXI Transaction Considerations | 261 |
| 9.2.3 DMA Manager | 261 |
| 9.2.4 Multi-channel Data FIFO (MFIFO) | 263 |

| | | |
|------------|---|------------|
| 9.2.5 | Memory-to-Memory Transfers | 263 |
| 9.2.6 | PL Peripheral AXI Transactions | 264 |
| 9.2.7 | PL Peripheral Request Interface | 264 |
| 9.2.8 | PL Peripheral - Length Managed by PL Peripheral | 267 |
| 9.2.9 | PL Peripheral - Length Managed by DMAC | 268 |
| 9.2.10 | Events and Interrupts | 269 |
| 9.2.11 | Aborts | 270 |
| 9.2.12 | Security | 272 |
| 9.2.13 | IP Configuration Options | 274 |
| 9.3 | Programming Guide for DMA Controller | 275 |
| 9.3.1 | Startup | 275 |
| 9.3.2 | Execute a DMA Transfer | 275 |
| 9.3.3 | Interrupt Service Routine | 275 |
| 9.3.4 | Register Overview | 276 |
| 9.4 | Programming Guide for DMA Engine | 277 |
| 9.4.1 | Write Microcode to Program CCRx for AXI Transactions | 278 |
| 9.4.2 | Memory-to-Memory Transfers | 278 |
| 9.4.3 | PL Peripheral DMA Transfer Length Management | 282 |
| 9.4.4 | Restart Channel using an Event | 284 |
| 9.4.5 | Interrupting a Processor | 285 |
| 9.4.6 | Instruction Set Reference | 285 |
| 9.5 | Programming Restrictions | 286 |
| 9.5.1 | Updating Channel Control Registers During a DMA Cycle | 287 |
| 9.6 | System Functions | 289 |
| 9.6.1 | Clocks | 289 |
| 9.6.2 | Resets | 289 |
| 9.6.3 | Reset Configuration of Controller | 289 |
| 9.7 | I/O Interface | 290 |
| 9.7.1 | AXI Master Interface | 290 |
| 9.7.2 | Peripheral Request Interface | 290 |

Chapter 10: DDR Memory Controller

| | | |
|-------------|--|------------|
| 10.1 | Introduction | 292 |
| 10.1.1 | Features | 293 |
| 10.1.2 | Block Diagram | 294 |
| 10.1.3 | Notices | 295 |
| 10.1.4 | Interconnect | 295 |
| 10.1.5 | DDR Memory Types, Densities, and Data Widths | 296 |
| 10.1.6 | I/O Signals | 296 |
| 10.2 | AXI Memory Port Interface (DDRI) | 298 |
| 10.2.1 | Introduction | 298 |
| 10.2.2 | Block Diagram | 299 |
| 10.2.3 | AXI Feature Support and Limitations | 299 |
| 10.2.4 | TrustZone | 300 |
| 10.3 | DDR Core and Transaction Scheduler (DDRC) | 300 |
| 10.3.1 | Row/Bank/Column Address Mapping | 301 |
| 10.4 | DDRC Arbitration | 301 |
| 10.4.1 | Priority, Aging Counter and Urgent Signals | 302 |
| 10.4.2 | Page-Match | 302 |
| 10.4.3 | Aging Counter | 303 |

| | | |
|-------------|--|------------|
| 10.4.4 | Stage 1 – AXI Port Arbitration | 303 |
| 10.4.5 | Stage 2 – Read Versus Write | 305 |
| 10.4.6 | High Priority Read Ports | 305 |
| 10.4.7 | Stage 3 – Transaction State | 306 |
| 10.4.8 | Read Priority Management | 308 |
| 10.4.9 | Write Combine | 308 |
| 10.4.10 | Credit Mechanism | 309 |
| 10.5 | Controller PHY (DDRP) | 309 |
| 10.6 | Functional Programming Model | 310 |
| 10.6.1 | Clock Operating Frequencies | 310 |
| 10.6.2 | DDR IOB Impedance Calibration | 311 |
| 10.6.3 | DDR IOB Configuration | 312 |
| 10.6.4 | DDR Controller Register Programming | 314 |
| 10.6.5 | DRAM Reset and Initialization | 314 |
| 10.6.6 | DDR Initialization Sequence | 314 |
| 10.6.7 | DRAM Input Impedance (ODT) Calibration | 316 |
| 10.6.8 | DRAM Output Impedance (R _{ON}) Calibration | 316 |
| 10.6.9 | DRAM Training | 317 |
| 10.6.10 | Write Data Eye Adjustment | 319 |
| 10.6.11 | Alternatives to Automatic DRAM Training | 319 |
| 10.6.12 | DRAM Write Latency Restriction | 322 |
| 10.7 | Register Overview | 322 |
| 10.7.1 | DDRI | 322 |
| 10.7.2 | DDRC | 323 |
| 10.7.3 | DDRP | 325 |
| 10.8 | Error Correction Code (ECC) | 326 |
| 10.8.1 | ECC Initialization | 326 |
| 10.8.2 | ECC Error Behavior | 326 |
| 10.8.3 | Data Mask During ECC Mode | 327 |
| 10.8.4 | ECC Programming Model | 327 |
| 10.9 | Operational Programming Model | 328 |
| 10.9.1 | Operating Modes | 328 |
| 10.9.2 | Changing Clock Frequencies | 328 |
| 10.9.3 | Power Down | 329 |
| 10.9.4 | Deep Power Down | 329 |
| 10.9.5 | Self Refresh | 330 |
| 10.9.6 | DDR Power Reduction | 330 |

Chapter 11: Static Memory Controller

| | | |
|-------------|-----------------------------|------------|
| 11.1 | Introduction | 332 |
| 11.1.1 | Features | 333 |
| 11.1.2 | Block Diagram | 334 |
| 11.1.3 | Notices | 335 |
| 11.2 | Functional Operation | 335 |
| 11.2.1 | Boot Device | 335 |
| 11.2.2 | Clocks | 335 |
| 11.2.3 | Resets | 336 |
| 11.2.4 | ECC Support | 336 |
| 11.2.5 | Interrupts | 336 |
| 11.2.6 | PL353 Functionality | 337 |
| 11.2.7 | Address Map | 337 |

| | |
|---------------------------------------|------------|
| 11.3 I/O Signals | 338 |
| 11.4 Wiring Diagrams | 339 |
| 11.5 Register Overview | 341 |
| 11.6 Programming Model | 341 |
| 11.7 NOR Flash Bandwidth | 341 |

Chapter 12: Quad-SPI Flash Controller

| | |
|---|------------|
| 12.1 Introduction | 343 |
| 12.1.1 Features | 343 |
| 12.1.2 System Viewpoint | 344 |
| 12.1.3 Block Diagram | 345 |
| 12.1.4 Notices | 345 |
| 12.2 Functional Description | 346 |
| 12.2.1 Operational Modes | 346 |
| 12.2.2 I/O Mode | 346 |
| 12.2.3 I/O Mode Transmit Registers (TXD) | 348 |
| 12.2.4 I/O Mode Considerations | 349 |
| 12.2.5 Linear Addressing Mode | 349 |
| 12.2.6 Unsupported Devices | 352 |
| 12.2.7 Supported Memory Read and Write Commands | 352 |
| 12.3 Programming Guide | 353 |
| 12.3.1 Configuration | 353 |
| 12.3.2 Linear Addressing Mode | 354 |
| 12.3.3 Configure I/O Mode | 354 |
| 12.3.4 I/O Mode Interrupts | 355 |
| 12.3.5 Rx/Tx FIFO Response to I/O Command Sequences | 356 |
| 12.3.6 Register Overview | 358 |
| 12.4 System Functions | 359 |
| 12.4.1 Clocks | 359 |
| 12.4.2 Resets | 360 |
| 12.5 I/O Interface | 361 |
| 12.5.1 Wiring Connections | 361 |
| 12.5.2 MIO Programming | 365 |
| 12.5.3 MIO Signals | 367 |

Chapter 13: SD/SDIO Controller

| | |
|---|------------|
| 13.1 Introduction | 368 |
| 13.1.1 Key Features | 369 |
| 13.1.2 System Viewpoint | 370 |
| 13.2 Functional Description | 370 |
| 13.2.1 AHB Interface and Interrupt Controller | 370 |
| 13.2.2 SD/SDIO Host Controller | 370 |
| 13.2.3 Data FIFO | 371 |
| 13.2.4 Command and Control Logic | 371 |
| 13.2.5 Bus Monitor | 371 |
| 13.2.6 Stream Write and Read | 372 |
| 13.2.7 Clocks | 372 |
| 13.2.8 Soft Resets | 372 |
| 13.2.9 FIFO Overrun and Underrun Conditions | 373 |

| | |
|---|------------|
| 13.3 Programming Model | 374 |
| 13.3.1 Data Transfer Protocol Overview | 374 |
| 13.3.2 Data Transfers Without DMA | 375 |
| 13.3.3 Using DMA | 377 |
| 13.3.4 Using ADMA | 380 |
| 13.3.5 Abort Transaction | 381 |
| 13.3.6 External Interface Usage Example | 383 |
| 13.3.7 Supported Configurations | 383 |
| 13.3.8 Bus Voltage Translation | 384 |
| 13.4 SDIO Controller Media Interface Signals | 384 |
| 13.4.1 SDIO EMIO Considerations | 386 |

Chapter 14: General Purpose I/O (GPIO)

| | |
|--|------------|
| 14.1 Introduction | 387 |
| 14.1.1 Features | 387 |
| 14.1.2 Block Diagram | 388 |
| 14.1.3 Notices | 389 |
| 14.2 Functional Description | 389 |
| 14.2.1 GPIO Control of Device Pins | 389 |
| 14.2.2 EMIO Signals | 391 |
| 14.2.3 Bank0, Bits[8:7] are Outputs | 391 |
| 14.2.4 Interrupt Function | 392 |
| 14.3 Programming Guide | 393 |
| 14.3.1 Start-up Sequence | 393 |
| 14.3.2 GPIO Pin Configurations | 393 |
| 14.3.3 Writing Data to GPIO Output Pins | 394 |
| 14.3.4 Reading Data from GPIO Input Pins | 394 |
| 14.3.5 GPIO as Wake-up Event | 395 |
| 14.3.6 Register Overview | 395 |
| 14.4 System Functions | 395 |
| 14.4.1 Clocks | 396 |
| 14.4.2 Resets | 396 |
| 14.4.3 Interrupts | 396 |
| 14.5 I/O Interface | 396 |
| 14.5.1 MIO Programming | 396 |

Chapter 15: USB Host, Device, and OTG Controller

| | |
|--|------------|
| 15.1 Introduction | 397 |
| 15.1.1 Features | 398 |
| 15.1.2 Operating Modes | 399 |
| 15.1.3 Hardware System Viewpoint | 399 |
| 15.1.4 Controller Block Diagram | 401 |
| 15.1.5 Configuration, Control and Status | 403 |
| 15.1.6 Data Structures | 403 |
| 15.1.7 Implementation Summary | 405 |
| 15.1.8 Documentation | 405 |
| 15.1.9 Notices | 407 |
| 15.1.10 Chapter Overview | 407 |
| 15.2 Functional Description | 408 |
| 15.2.1 Controller Flow Diagram | 408 |

| | | |
|--------------|--|------------|
| 15.2.2 | DMA Engine | 408 |
| 15.2.3 | Protocol Engine | 409 |
| 15.2.4 | Port Controller | 410 |
| 15.2.5 | ULPI Link Wrapper | 410 |
| 15.2.6 | General Purpose Timers | 411 |
| 15.3 | Programming Overview and Reference | 411 |
| 15.3.1 | Hardware/Software System | 412 |
| 15.3.2 | Operational Mode Control | 412 |
| 15.3.3 | Power Management | 413 |
| 15.3.4 | Register Overview | 413 |
| 15.3.5 | Interrupt and Status Bits Overview | 415 |
| 15.3.6 | OTG Status/Interrupt and Control Register | 416 |
| 15.4 | Device Mode Control | 416 |
| 15.4.1 | Controller State | 417 |
| 15.4.2 | USB Bus Reset Response | 418 |
| 15.5 | Device Endpoint Data Structures | 419 |
| 15.5.1 | Link-list Endpoint Descriptors | 419 |
| 15.5.2 | Manage Endpoints | 421 |
| 15.5.3 | Endpoint Registers | 422 |
| 15.5.4 | Endpoint Initialization | 423 |
| 15.6 | Device Endpoint Packet Operational Model | 425 |
| 15.6.1 | Prime Transmit Endpoints | 425 |
| 15.6.2 | Prime Receive Endpoints | 426 |
| 15.6.3 | Interrupt and Bulk Endpoint Operational Model | 426 |
| 15.6.4 | Isochronous Endpoint Operational Model | 429 |
| 15.6.5 | Control Endpoint Operational Model | 431 |
| 15.7 | Device Endpoint Descriptor Reference | 433 |
| 15.7.1 | Endpoint Queue Head Descriptor (dQH) | 434 |
| 15.7.2 | Endpoint Transfer Descriptor (dTD) | 435 |
| 15.7.3 | Endpoint Transfer Overlay Area | 436 |
| 15.8 | Programming Guide for Device Controller | 438 |
| 15.8.1 | Software Model | 439 |
| 15.8.2 | USB Reset | 439 |
| 15.8.3 | Register Controlled Reset | 439 |
| 15.9 | Programming Guide for Device Endpoint Data Structures | 439 |
| 15.9.1 | Device Controller Initialization Overview | 439 |
| 15.9.2 | Manage Transfer Descriptors | 440 |
| 15.9.3 | Manage Transfers with Transfer Descriptors | 442 |
| 15.9.4 | Service Device Mode Interrupts | 444 |
| 15.10 | Host Mode Data Structures | 446 |
| 15.10.1 | Host Controller Transfer Schedule Structures | 446 |
| 15.10.2 | Periodic Schedule | 447 |
| 15.10.3 | Asynchronous Schedule | 448 |
| 15.11 | EHCI Implementation | 449 |
| 15.11.1 | Overview | 449 |
| 15.11.2 | Embedded Transaction Translator | 451 |
| 15.11.3 | EHCI Functional Changes for the TT | 453 |
| 15.11.4 | Port Reset Timer Enhancement | 453 |
| 15.11.5 | Port Speed Detection Mechanism | 454 |
| 15.11.6 | FS/LS Data Structures | 454 |
| 15.11.7 | Operational Model of the TT | 455 |

| | | |
|--------------|--|------------|
| 15.11.8 | Port Test Mode | 456 |
| 15.12 | Host Data Structures Reference | 457 |
| 15.12.1 | Descriptor Usage | 457 |
| 15.12.2 | Transfer Descriptor Type (TYP) Field | 457 |
| 15.12.3 | Isochronous (High Speed) Transfer Descriptor (iTd) | 458 |
| 15.12.4 | Split Transaction Isochronous Transfer Descriptor (siTD) | 462 |
| 15.12.5 | Queue Element Transfer Descriptor (qTD) | 466 |
| 15.12.6 | Queue Head (QH) | 470 |
| 15.12.7 | Transfer Overlay Area | 473 |
| 15.12.8 | Periodic Frame Span Traversal Node (FSTN) | 475 |
| 15.13 | Programming Guide for Host Controller | 476 |
| 15.13.1 | Controller Reset | 476 |
| 15.13.2 | Run/Stop | 476 |
| 15.14 | OTG Description and Reference | 476 |
| 15.14.1 | Hardware Assistance Features | 477 |
| 15.14.2 | OTG Interrupt and Control Bits | 478 |
| 15.15 | System Functions | 479 |
| 15.15.1 | Clocks | 479 |
| 15.15.2 | Reset Types | 480 |
| 15.15.3 | System Interrupt | 481 |
| 15.15.4 | APB Slave Interface | 481 |
| 15.15.5 | AHB Master Interface | 481 |
| 15.16 | I/O Interfaces | 482 |
| 15.16.1 | Wiring Connections | 482 |
| 15.16.2 | MIO-EMIO Programming | 482 |
| 15.16.3 | MIO-EMIO Signals | 483 |

Chapter 16: Gigabit Ethernet Controller

| | | |
|-------------|---|------------|
| 16.1 | Introduction | 485 |
| 16.1.1 | Block Diagram | 486 |
| 16.1.2 | Features | 486 |
| 16.1.3 | System Viewpoint | 487 |
| 16.1.4 | Clock Domains | 488 |
| 16.1.5 | Notices | 488 |
| 16.1.6 | Application Notes | 488 |
| 16.2 | Functional Description and Programming Model | 489 |
| 16.2.1 | MAC Transmitter | 489 |
| 16.2.2 | MAC Receiver | 490 |
| 16.2.3 | MAC Filtering | 491 |
| 16.2.4 | Wake-on-LAN Support | 494 |
| 16.2.5 | DMA Block | 495 |
| 16.2.6 | Checksum Offloading | 505 |
| 16.2.7 | MAC 802.3 Pause Frame Support | 507 |
| 16.3 | Programming Guide | 511 |
| 16.3.1 | Initialize the Controller | 511 |
| 16.3.2 | Configure the Controller | 512 |
| 16.3.3 | I/O Configuration | 513 |
| 16.3.4 | Configure the PHY | 514 |
| 16.3.5 | Configure the Buffer Descriptors | 515 |
| 16.3.6 | Configure Interrupts | 517 |

| | |
|--|------------|
| 16.3.7 Enable the Controller | 518 |
| 16.3.8 Transmitting Frames | 518 |
| 16.3.9 Receiving Frames | 519 |
| 16.3.10 Debug Guide | 520 |
| 16.4 IEEE 1588 Timestamping | 521 |
| 16.5 Register Overview. | 521 |
| 16.5.1 Control Registers | 521 |
| 16.5.2 Status and Statistics Registers | 522 |
| 16.6 Signals and I/O Connections | 524 |
| 16.6.1 MIO–EMIO Interface Routing | 524 |
| 16.6.2 Programmable Logic (PL) Implementations | 524 |
| 16.6.3 RGMII Interface via MIO | 524 |
| 16.6.4 GMII/MII Interface via EMIO | 526 |
| 16.6.5 MDIO Interface Signals via MIO and EMIO | 527 |
| 16.6.6 MIO Pin Considerations | 527 |
| 16.7 Known Issues | 527 |

Chapter 17: SPI Controller

| | |
|--|------------|
| 17.1 Introduction | 529 |
| 17.1.1 Features | 530 |
| 17.1.2 System Viewpoint | 531 |
| 17.1.3 Block Diagram | 532 |
| 17.1.4 Notices | 533 |
| 17.2 Functional Description | 534 |
| 17.2.1 Master Mode | 534 |
| 17.2.2 Multi-Master Capability | 536 |
| 17.2.3 Slave Mode | 536 |
| 17.2.4 FIFOs | 537 |
| 17.2.5 FIFO Interrupts | 538 |
| 17.2.6 Interrupt Register Bits, Logic Flow | 538 |
| 17.2.7 SPI-to-SPI Connection | 539 |
| 17.3 Programming Guide | 539 |
| 17.3.1 Start-up Sequence | 539 |
| 17.3.2 Controller Configuration | 540 |
| 17.3.3 Master Mode Data Transfer | 540 |
| 17.3.4 Slave Mode Data Transfer | 542 |
| 17.3.5 Interrupt Service Routine | 542 |
| 17.3.6 Register Overview | 543 |
| 17.4 System Functions | 544 |
| 17.4.1 Resets | 544 |
| 17.4.2 Clocks | 544 |
| 17.5 I/O Interfaces | 545 |
| 17.5.1 Protocol | 546 |
| 17.5.2 Back-to-Back Transfers | 547 |
| 17.5.3 MIO/EMIO Routing | 548 |
| 17.5.4 Wiring Connections | 549 |
| 17.5.5 MIO/EMIO Signal Tables | 552 |

Chapter 18: CAN Controller

| | |
|------------------------------------|------------|
| 18.1 Introduction | 554 |
|------------------------------------|------------|

| | | |
|-------------|-------------------------------|------------|
| 18.1.1 | Features | 554 |
| 18.1.2 | System Viewpoint | 555 |
| 18.1.3 | Block Diagram | 555 |
| 18.1.4 | Notices | 556 |
| 18.2 | Functional Description | 557 |
| 18.2.1 | Controller Modes | 557 |
| 18.2.2 | Message Format | 560 |
| 18.2.3 | Message Buffering | 562 |
| 18.2.4 | Interrupts | 564 |
| 18.2.5 | Rx Message Filtering | 566 |
| 18.2.6 | Protocol Engine | 569 |
| 18.2.7 | CAN0-to-CAN1 Connection | 571 |
| 18.3 | Programming Guide | 572 |
| 18.3.1 | Overview | 572 |
| 18.3.2 | Configuration Mode State | 572 |
| 18.3.3 | Start-up Controller | 573 |
| 18.3.4 | Change Operating Mode | 573 |
| 18.3.5 | Write Messages to TxFIFO | 574 |
| 18.3.6 | Write Messages to TxHPB | 574 |
| 18.3.7 | Read Messages from RxFIFO | 574 |
| 18.3.8 | Register Overview | 575 |
| 18.4 | System Functions | 576 |
| 18.4.1 | Clocks | 576 |
| 18.4.2 | Resets | 577 |
| 18.5 | I/O Interface | 578 |
| 18.5.1 | MIO Programming | 578 |
| 18.5.2 | MIO-EMIO Signals | 579 |

Chapter 19: UART Controller

| | | |
|-------------|--------------------------------|------------|
| 19.1 | Introduction | 580 |
| 19.1.1 | Features | 580 |
| 19.1.2 | System Viewpoint | 581 |
| 19.1.3 | Notices | 581 |
| 19.2 | Functional Description | 582 |
| 19.2.1 | Block Diagram | 582 |
| 19.2.2 | Control Logic | 582 |
| 19.2.3 | Baud Rate Generator | 582 |
| 19.2.4 | Transmit FIFO | 584 |
| 19.2.5 | Transmitter Data Stream | 584 |
| 19.2.6 | Receiver FIFO | 585 |
| 19.2.7 | Receiver Data Capture | 585 |
| 19.2.8 | I/O Mode Switch | 587 |
| 19.2.9 | UART0-to-UART1 Connection | 589 |
| 19.2.10 | Status and Interrupts | 589 |
| 19.2.11 | Modem Control | 591 |
| 19.3 | Programming Guide | 593 |
| 19.3.1 | Start-up Sequence | 593 |
| 19.3.2 | Configure Controller Functions | 594 |
| 19.3.3 | Transmit Data | 595 |
| 19.3.4 | Receive Data | 596 |
| 19.3.5 | RxFIFO Trigger Level Interrupt | 596 |

| | |
|--|------------|
| 19.3.6 Register Overview | 597 |
| 19.4 System Functions | 598 |
| 19.4.1 Clocks | 598 |
| 19.4.2 Resets | 598 |
| 19.5 I/O Interface | 599 |
| 19.5.1 MIO Programming | 599 |
| 19.5.2 MIO – EMIO Signals | 600 |

Chapter 20: I2C Controller

| | |
|--|------------|
| 20.1 Introduction | 601 |
| 20.1.1 Features | 601 |
| 20.1.2 System Block Diagram | 602 |
| 20.1.3 Notices | 602 |
| 20.2 Functional Description | 603 |
| 20.2.1 Block Diagram | 603 |
| 20.2.2 Master Mode | 603 |
| 20.2.3 Slave Monitor Mode | 605 |
| 20.2.4 Slave Mode | 605 |
| 20.2.5 I2C Speed | 606 |
| 20.2.6 Multi-Master Operation | 607 |
| 20.2.7 I2C0-to-I2C1 Connection | 608 |
| 20.2.8 Status and Interrupts | 608 |
| 20.3 Programmer’s Guide. | 609 |
| 20.3.1 Start-up Sequence | 609 |
| 20.3.2 Controller Configuration | 609 |
| 20.3.3 Configure Interrupts | 610 |
| 20.3.4 Data Transfers | 610 |
| 20.3.5 Register Overview | 613 |
| 20.4 System Functions | 613 |
| 20.4.1 Clocks | 613 |
| 20.4.2 Reset Controller | 613 |
| 20.5 I/O Interface | 614 |
| 20.5.1 Pin Programming | 614 |
| 20.5.2 MIO-EMIO Interfaces | 614 |

Chapter 21: Programmable Logic Description

| | |
|--|------------|
| 21.1 Introduction | 616 |
| 21.1.1 Features | 616 |
| 21.1.2 PL Resources by Device Type | 618 |
| 21.1.3 Notices | 619 |
| 21.2 PL Components | 619 |
| 21.2.1 CLBs, Slices, and LUTs | 619 |
| 21.2.2 Clock Management | 620 |
| 21.2.3 Block RAM | 621 |
| 21.2.4 Digital Signal Processing — DSP Slice | 623 |
| 21.3 Input/Output | 623 |
| 21.3.1 PS-PL Interfaces | 623 |
| 21.3.2 SelectIO | 624 |
| 21.3.3 GTX Low-Power Serial Transceivers | 626 |

| | |
|--|------------|
| 21.3.4 GTP Low-Power Serial Transceivers | 641 |
| 21.3.5 Integrated I/O Block for PCIe | 642 |
| 21.4 Configuration | 643 |

Chapter 22: Programmable Logic Design Guide

| | |
|--|------------|
| 22.1 Introduction | 644 |
| 22.2 Programmable Logic for Software Offload | 644 |
| 22.2.1 Benefits of Using PL to Implement Software Algorithms | 644 |
| 22.2.2 Designing PL Accelerators | 645 |
| 22.2.3 PL Acceleration Limits | 646 |
| 22.2.4 Power Offload | 646 |
| 22.2.5 Real Time Offload | 647 |
| 22.2.6 Reconfigurable Computing | 648 |
| 22.3 PL and Memory System Performance Overview | 649 |
| 22.3.1 Theoretical Bandwidth | 649 |
| 22.3.2 DDR Efficiency | 650 |
| 22.3.3 OCM Efficiency | 651 |
| 22.3.4 Interconnect Throughput Bottlenecks | 651 |
| 22.4 Choosing a Programmable Logic Interface | 652 |
| 22.4.1 PL Interface Comparison Summary | 652 |
| 22.4.2 Cortex-A9 CPU via General Purpose Masters | 652 |
| 22.4.3 PS DMA Controller (DMAC) via General Purpose Masters | 653 |
| 22.4.4 PL DMA via AXI High-Performance (HP) Interface | 654 |
| 22.4.5 PL DMA via AXI ACP | 655 |
| 22.4.6 PL DMA via General Purpose AXI Slave (GP) | 656 |

Chapter 23: Programmable Logic Test and Debug

| | |
|--|------------|
| 23.1 Introduction | 657 |
| 23.1.1 Features | 657 |
| 23.1.2 Block Diagram | 658 |
| 23.1.3 System Viewpoint | 659 |
| 23.2 Functional Description | 659 |
| 23.2.1 Basic Operation | 659 |
| 23.2.2 Packet Generation | 660 |
| 23.2.3 Packet Format | 662 |
| 23.3 Signals | 665 |
| 23.3.1 General-Purpose Debug Signals | 665 |
| 23.3.2 Trigger Signals | 665 |
| 23.3.3 Trace Signals | 666 |
| 23.4 Register Overview | 666 |
| 23.5 Programming Model | 667 |
| 23.5.1 FTM Security | 667 |

Chapter 24: Power Management

| | |
|--|------------|
| 24.1 Introduction | 668 |
| 24.1.1 Features | 668 |
| 24.2 System Design Considerations | 669 |
| 24.2.1 Device Technology Choice | 669 |

| | | |
|-------------|--|------------|
| 24.2.2 | PL Power-down Control | 669 |
| 24.2.3 | APU Maximum Frequency | 670 |
| 24.2.4 | DDR Memory Clock Frequency | 670 |
| 24.2.5 | DDR Memory Controller Modes and Configurations | 670 |
| 24.2.6 | Boot Interface Options | 670 |
| 24.2.7 | PS Clock Gating | 670 |
| 24.3 | Programming Guides | 671 |
| 24.3.1 | System Modules | 671 |
| 24.3.2 | Peripherals | 671 |
| 24.3.3 | I/O Buffers | 672 |
| 24.4 | Sleep Mode | 673 |
| 24.4.1 | Setup Wake-up Events | 673 |
| 24.4.2 | Programming Guide | 673 |
| 24.5 | Register Overview | 675 |

Chapter 25: Clocks

| | | |
|--------------|---|------------|
| 25.1 | Introduction | 676 |
| 25.1.1 | System Block Diagram | 676 |
| 25.1.2 | Clock Generation | 677 |
| 25.1.3 | System Viewpoint | 678 |
| 25.1.4 | Power Management | 679 |
| 25.2 | CPU Clock | 680 |
| 25.3 | System-wide Clock Frequency Examples | 682 |
| 25.4 | Clock Generator Design | 684 |
| 25.5 | DDR Clocks | 685 |
| 25.6 | IOP Module Clocks | 686 |
| 25.6.1 | USB Clocks | 686 |
| 25.6.2 | Ethernet Clocks | 687 |
| 25.6.3 | SDIO, SMC, SPI, Quad-SPI and UART Clocks | 688 |
| 25.6.4 | CAN Clocks | 689 |
| 25.6.5 | GPIO and I2C Clocks | 689 |
| 25.7 | PL Clocks | 689 |
| 25.7.1 | Clock Throttle | 690 |
| 25.7.2 | Clock Throttle Programming | 691 |
| 25.8 | Trace Port Clock | 693 |
| 25.9 | Register Overview | 693 |
| 25.10 | Programming Model | 694 |
| 25.10.1 | Branch Clock Generator | 694 |
| 25.10.2 | DDR Clocks | 695 |
| 25.10.3 | Digitally Controlled Impedance (DCI) Clock | 695 |
| 25.10.4 | PLLs | 695 |

Chapter 26: Reset System

| | | |
|-------------|---------------------|------------|
| 26.1 | Introduction | 698 |
| 26.1.1 | Features | 698 |
| 26.1.2 | Block Diagram | 698 |
| 26.1.3 | Reset Hierarchy | 699 |
| 26.1.4 | Boot Flow | 700 |

| | |
|--|------------|
| 26.2 Reset Sources | 701 |
| 26.2.1 Power-on Reset (PS_POR_B) | 701 |
| 26.2.2 External System Reset (PS_SRST_B) | 702 |
| 26.2.3 System Software Reset | 702 |
| 26.2.4 Watchdog Timer Resets | 702 |
| 26.2.5 Secure Violation Lock Down | 702 |
| 26.2.6 Debug Resets | 702 |
| 26.3 Reset Effects | 703 |
| 26.3.1 Peripherals | 703 |
| 26.4 PL Resets | 704 |
| 26.4.1 PL General Purpose User Resets | 704 |
| 26.5 Register Overview | 704 |
| 26.5.1 Persistent Registers | 704 |
| 26.5.2 System Reset Control | 705 |
| 26.5.3 Peripheral Reset Control | 705 |

Chapter 27: JTAG and DAP Subsystem

| | |
|---|------------|
| 27.1 Introduction | 707 |
| 27.1.1 Block Diagram | 707 |
| 27.1.2 Features | 709 |
| 27.2 Functional Description | 710 |
| 27.3 I/O Signals | 712 |
| 27.4 Programming Model | 713 |
| 27.4.1 Use Case I: Software Debug with Trace Port Enabled | 713 |
| 27.4.2 Use Case II: PS and PL Debug with Trace Port Enabled | 713 |
| 27.5 Arm DAP Controller | 714 |
| 27.6 Trace Port Interface Unit (TPIU) | 716 |
| 27.7 Xilinx TAP Controller | 716 |

Chapter 28: System Test and Debug

| | |
|--|------------|
| 28.1 Introduction | 718 |
| 28.1.1 Features | 718 |
| 28.1.2 Notices | 719 |
| 28.2 Functional Description | 719 |
| 28.2.1 Debug Access Port (DAP) | 720 |
| 28.2.2 Embedded Cross Trigger (ECT) | 721 |
| 28.2.3 Program Trace Macrocell (PTM) | 723 |
| 28.2.4 Instrumentation Trace Macrocell (ITM) | 723 |
| 28.2.5 Funnel | 723 |
| 28.2.6 Embedded Trace Buffer (ETB) | 724 |
| 28.2.7 Trace Packet Output (TPIU) | 724 |
| 28.3 I/O Signals | 725 |
| 28.4 Register Overview | 726 |
| 28.4.1 Memory Map | 726 |
| 28.4.2 Functionality | 727 |
| 28.5 Programming Model | 730 |
| 28.5.1 Authentication Requirements | 730 |

Chapter 29: On-Chip Memory (OCM)

| | |
|------------------------------------|------------|
| 29.1 Introduction | 732 |
| 29.1.1 Block Diagram | 733 |
| 29.1.2 Features | 733 |
| 29.1.3 System Viewpoint | 734 |
| 29.2 Functional Description | 735 |
| 29.2.1 Overview | 735 |
| 29.2.2 Optimal Transfer Alignment | 735 |
| 29.2.3 Clocking | 735 |
| 29.2.4 Arbitration Scheme | 735 |
| 29.2.5 Address Mapping | 737 |
| 29.2.6 Interrupts | 740 |
| 29.3 Register Overview | 741 |
| 29.4 Programming Model | 741 |
| 29.4.1 Changing Address Mapping | 741 |
| 29.4.2 AXI Responses | 742 |

Chapter 30: XADC Interface

| | |
|---|------------|
| 30.1 Introduction | 743 |
| 30.1.1 Features | 744 |
| 30.1.2 System Viewpoint | 745 |
| 30.1.3 PS-XADC Interface Block Diagram | 746 |
| 30.1.4 Programming Guide | 747 |
| 30.2 Functional Description | 748 |
| 30.2.1 Interface Arbiter (PL-JTAG and PS-XADC) | 748 |
| 30.2.2 Serial Communication Channel (PL-JTAG and PS-XADC) | 749 |
| 30.2.3 Analog-to-Digital Converter (All) | 749 |
| 30.2.4 Sensor Alarms (PS-XADC and DRP) | 749 |
| 30.3 PS-XADC Interface Description | 750 |
| 30.3.1 Serial Channel Clock Frequency | 750 |
| 30.3.2 Command and Data Packets | 751 |
| 30.3.3 Command Format | 752 |
| 30.3.4 Read Data Format | 752 |
| 30.3.5 Min/Max Voltage Thresholds | 753 |
| 30.3.6 Critical Over-temperature Alarm | 753 |
| 30.4 Programming Guide for the PS-XADC Interface | 753 |
| 30.4.1 Read and Write to the FIFOs | 754 |
| 30.4.2 Interrupts | 755 |
| 30.4.3 Command Preparation | 756 |
| 30.4.4 Register Overview | 756 |
| 30.5 Programming Guide for the DRP Interface | 757 |
| 30.6 Programming Guide for the PL-JTAG Interface | 757 |
| 30.7 System Functions | 757 |
| 30.7.1 Clocks | 757 |
| 30.7.2 Resets | 758 |

Chapter 31: PCI Express

| | |
|--------------------------|------------|
| 31.1 Introduction | 759 |
|--------------------------|------------|

| | |
|---|------------|
| 31.2 Block Diagram | 760 |
| 31.3 Features | 760 |
| 31.4 Endpoint Use Case | 761 |
| 31.5 Root Complex Use Case | 761 |

Chapter 32: Device Secure Boot

| | |
|---|------------|
| 32.1 Introduction | 763 |
| 32.1.1 Block Diagram | 763 |
| 32.1.2 Features | 763 |
| 32.2 Functional Description | 765 |
| 32.2.1 Master Secure Boot | 765 |
| 32.2.2 External Boot Devices | 767 |
| 32.2.3 Secure Boot Image | 767 |
| 32.2.4 eFUSE Settings | 769 |
| 32.2.5 RSA Authentication | 771 |
| 32.2.6 Boot Image and Bitstream Encryption | 771 |
| 32.2.7 Boot Image and Bitstream Decryption and Authentication | 772 |
| 32.2.8 HMAC Signature | 772 |
| 32.2.9 AES Key Management | 772 |
| 32.3 Secure Boot Features | 772 |
| 32.3.1 Non-Secure Boot State | 772 |
| 32.3.2 Secure Boot State | 773 |
| 32.3.3 Security Lockdown | 773 |
| 32.3.4 Boot Partition Search | 773 |
| 32.3.5 JTAG and Debug Considerations | 773 |
| 32.3.6 Readback | 774 |
| 32.3.7 Secure Boot Modes of Operation | 774 |
| 32.4 Programming Considerations | 775 |

Appendix A: Additional Resources

| | |
|---|------------|
| A.1 Xilinx Resources | 776 |
| A.2 Solution Centers | 777 |
| A.3 References | 777 |
| A.3.1 Zynq-7000 SoC Documents | 777 |
| A.3.2 PL Documents – Device and Boards | 777 |
| A.3.3 Additional Zynq-7000 SoC Documents | 778 |
| A.3.4 Software Programming Documents | 778 |
| A.3.5 git Information | 778 |
| A.3.6 Design Tool Resources | 779 |
| A.3.7 Xilinx Problem Solvers | 779 |
| A.3.8 Third-Party IP and Standards Documents | 779 |
| • Please Read: Important Legal Notices | 780 |

Appendix B: Register Details

| | |
|---------------------------------|------------|
| B.1 Overview | 782 |
| B.2 Acronyms | 783 |
| B.3 Module Summary | 784 |

| | |
|--|------|
| B.4 AXI_HP Interface (AFI) (axi_hp) | 786 |
| B.5 CAN Controller (can). | 796 |
| B.6 DDR Memory Controller (ddrc) | 835 |
| B.7 CoreSight Cross Trigger Interface (cti). | 906 |
| B.8 Performance Monitor Unit (cortexa9_pmu). | 940 |
| B.9 CoreSight Program Trace Macrocell (ptm) | 950 |
| B.10 Debug Access Port (dap) | 998 |
| B.11 CoreSight Embedded Trace Buffer (etb) | 1013 |
| B.12 PL Fabric Trace Monitor (ftm) | 1033 |
| B.13 CoreSight Trace Funnel (funnel) | 1054 |
| B.14 CoreSight Instrumentation Trace Macrocell (itm) | 1068 |
| B.15 CoreSight Trace Packet Output (tpiu) | 1115 |
| B.16 Device Configuration Interface (devcfg) | 1136 |
| B.17 DMA Controller (dmac) | 1159 |
| B.18 Gigabit Ethernet Controller (GEM) | 1259 |
| B.19 General Purpose I/O (gpio) | 1327 |
| B.20 Interconnect QoS (qos301) | 1356 |
| B.21 NIC301 Address Region Control (nic301_addr_region_ctrl_registers) | 1362 |
| B.22 I2C Controller (IIC) | 1364 |
| B.23 L2 Cache (L2Cpl310) | 1375 |
| B.24 Application Processing Unit (mpcore). | 1412 |
| B.25 On-Chip Memory (ocm) | 1492 |
| B.26 Quad-SPI Flash Controller (qspi) | 1496 |
| B.27 SD Controller (sdio) | 1513 |
| B.28 System Level Control Registers (slcr) | 1552 |
| B.29 Static Memory Controller (pl353) | 1692 |
| B.30 SPI Controller (SPI) | 1719 |
| B.31 System Watchdog Timer (swdt) | 1730 |
| B.32 Triple Timer Counter (ttc) | 1734 |
| B.33 UART Controller (UART) | 1755 |
| B.34 USB Controller (usb) | 1774 |

Introduction

1.1 Overview

The Zynq®-7000 family is based on the Xilinx® SoC architecture. These products integrate a feature-rich dual or single-core Arm® Cortex™-A9 MPCore™ based processing system (PS) and Xilinx programmable logic (PL) in a single device, built on a state-of-the-art, high-performance, low-power (HPL), 28 nm, and high-k metal gate (HKMG) process technology. The Arm Cortex-A9 MPCore CPUs are the heart of the PS which also includes on-chip memory, external memory interfaces, and a rich set of I/O peripherals.

The Zynq-7000 family offers the flexibility and scalability of an FPGA, while providing performance, power, and ease of use typically associated with ASIC and ASSPs. The range of devices in the Zynq-7000 SoC family enables designers to target cost-sensitive as well as high-performance applications from a single platform using industry-standard tools. While each device in the Zynq-7000 family contains the same PS, the PL and I/O resources vary between the devices. As a result, the Zynq-7000 SoC devices are able to serve a wide range of applications including:

- Automotive driver assistance, driver information, and infotainment
- Broadcast camera
- Industrial motor control, industrial networking, and machine vision
- IP and smart camera
- LTE radio and baseband
- Medical diagnostics and imaging
- Multifunction printers
- Video and night vision equipment

The Zynq-7000 architecture conveniently maps the custom logic and software in the PL and PS respectively. It enables the realization of unique and differentiated system functions. The integration of the PS with the PL provides levels of performance that two-chip solutions (for example, an ASSP with an FPGA) cannot match due to their limited I/O bandwidth, loose-coupling and power budgets.

Xilinx and the Xilinx Alliance partners offer a large number of soft IP modules for the Zynq-7000 family. Stand-alone and Linux device drivers are available for the peripherals in the PS and the PL from Xilinx and additional OSEs and board support packages (BSPs) from partners. The ISE® Design Suite Embedded Edition development environment enables a rapid product development for software, hardware, and systems engineers. Many third-party software development tools are also available.

The processor(s) in the PS always boot first, allowing a software centric approach for PL system boot and PL configuration. The PL can be configured as part of the boot process or configured at some point in the future. Additionally, the PL can be completely reconfigured or used with partial, dynamic reconfiguration (PR). PR allows configuration of a portion of the PL. This enables optional design changes such as updating coefficients or time-multiplexing of the PL resources by swapping in new algorithms as needed. This latter capability is analogous to the dynamic loading and unloading of software modules. The PL configuration data is referred to as a bitstream.

1.1.1 Block Diagram

Figure 1-1 illustrates the functional blocks of the Zynq-7000 SoC. The PS and the PL are on separate power domains, enabling the user of these devices to power down the PL for power management if required.

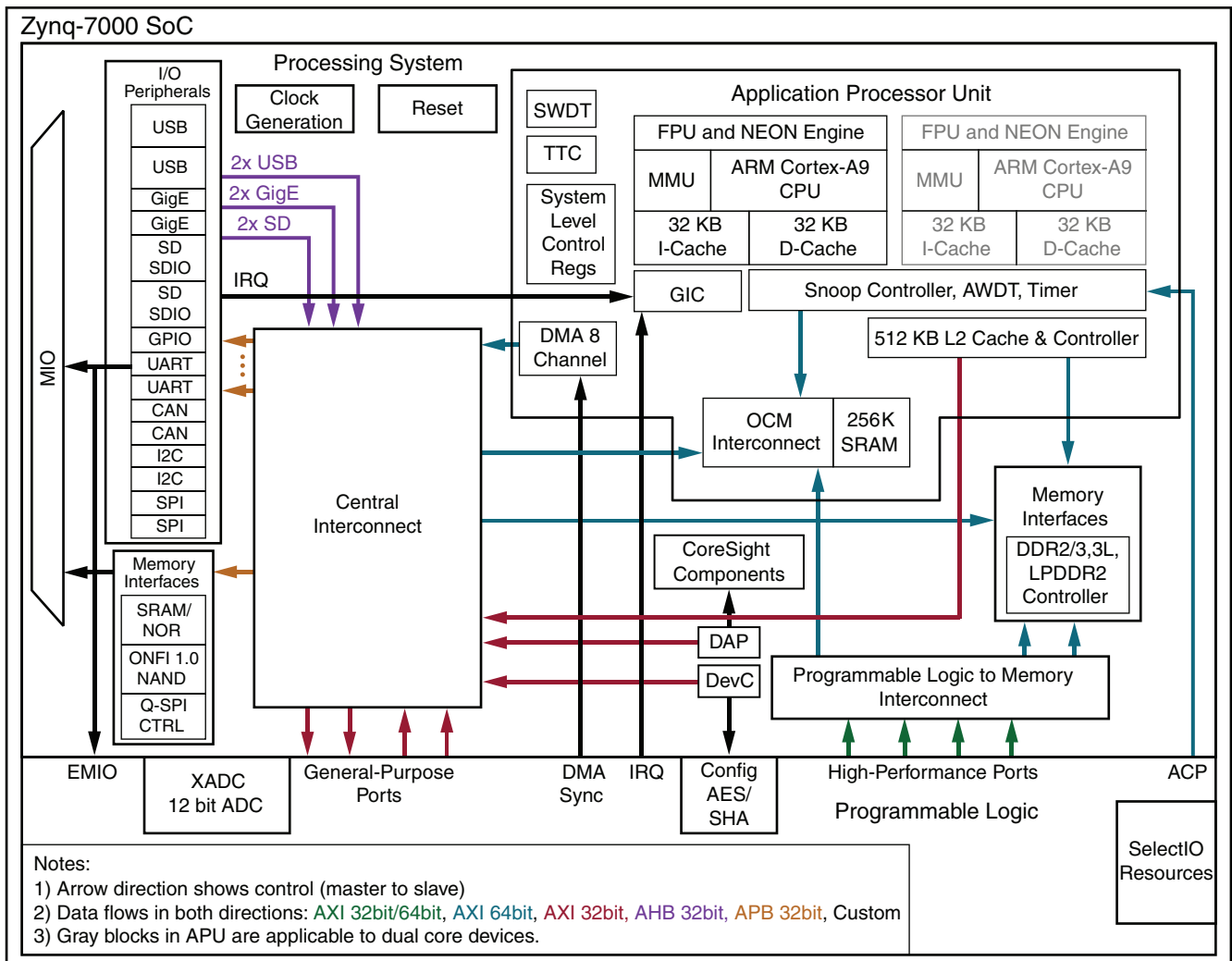

UG585_c1_01_060618

Figure 1-1: Zynq-7000 SoC Overview

The Zynq-7000 SoC is composed of the following major functional blocks:

- Processing System (PS)
 - Application processor unit (APU)
 - Memory interfaces
 - I/O peripherals (IOP)
 - Interconnect
- Programmable Logic (PL)

1.1.2 Documentation Resources

Table 1-1 identifies the versions of third-party IP used in the Zynq-7000 SoC devices.

Table 1-1: Vendor IP Versions

| Unit | Supplier | Version |
|--|----------|-------------------|
| Cortex-A9 MPCore | Arm | r3p0 |
| AMBA Level 2 Cache Controller (PL310) | Arm | r3p2-50rel0 |
| PrimeCell Static Memory Controller (PL353) | Arm | r2p1 |
| PrimeCell DMA Controller (PL330) | Arm | r1p1 |
| Generic Interrupt Controller (PL390) | Arm | Arch v1.0, r0p0 |
| CoreLink Network Interconnect (NIC-301) | Arm | r2p2 |
| DesignWare Cores IntelliDDR Multi Protocol Memory Controller | Synopsys | A07 |
| USB 2.0 High Speed Atlantic Controller | Synopsys | 2.20a |
| Watchdog Timer | Cadence | Rev 07 |
| Inter Intergrated Circuit | Cadence | r1p10 |
| Gigabit Ethernet MAC | Cadence | r1p23 |
| Serial Peripheral Interface | Cadence | r1p06 |
| Universal Asynchronous Receiver Transmitter | Cadence | r1p08 |
| Triple Timer Counter | Cadence | Rev 06 |
| SD2.0/SDIO2.0/MMC3.31 AHB Host Controller | Arasan | 8.9A_apr02nd_2010 |

The PL is derived from Xilinx 7 series FPGA technology: Artix®-7 for the 7z010/7z015/7z020 (dual core devices) and 7z007s/7z012s/7z014s (single core devices), and Kintex®-7 for the 7z030/7z035/7z045/7z100 devices. The PL is used to extend the functionality to meet specific application requirements. The PL includes many different types of resources including configurable logic blocks (CLBs), port and width configurable block RAM (BRAM), DSP slices with a 25 x 18 multiplier, 48-bit accumulator and pre-adder (DSP48E1), a user configurable analog to digital convertor (XADC), clock management tiles (CMT), a configuration block with 256b AES for decryption and SHA for authentication, configurable SelectIO™ technology and optionally GTP or GTX multi-gigabit transceivers and an integrated PCI Express® (PCIe) block.

To learn more about the PL resources, refer to the following Xilinx 7 series FPGA User Guides:

- UG471, *7 Series FPGAs SelectIO Resources User Guide*
- UG472, *7 Series FPGAs Clocking Resources User Guide*
- UG473, *7 Series FPGAs Memory Resources User Guide*
- UG474, *7 Series FPGAs Configurable Logic Block User Guide*
- UG476, *7 Series FPGAs GTX Transceiver User Guide*
- UG482, *7 Series FPGAs GTP Transceiver User Guide*
- PG054, *7 Series FPGAs Integrated Block for PCI Express LogiCORE IP Product Guide*
- UG479, *7 Series FPGAs DSP48E1 User Guide*
- UG480, *7 Series FPGAs XADC User Guide*

The PS and PL can be tightly or loosely coupled using multiple interfaces and other signals that have a combined total of over 3,000 connections. This enables you to effectively integrate user-created hardware accelerators and other functions in the PL logic that are accessible to the processors and can also access memory resources in the processing system.

The PS I/O peripherals, including the static/flash memory interfaces share a multiplexed I/O (MIO) of up to 54 MIO pins. Zynq-7000 SoC devices also include the capability to use the I/Os that are part of the PL domain for many of the PS I/O peripherals. This is done through an extended multiplexed I/O interface (EMIO).

The system includes many types of security, test and debug features. The Zynq-7000 SoC can be booted securely or non-securely. The PL configuration bitstream can be applied securely or non-securely. Both of these use the 256b AES decryption and SHA authentication blocks that are part of the PL. Therefore, to use these security features, the PL must be powered on.

The boot process is multi-stage and minimally includes the boot ROM and the first-stage boot loader (FSBL). The Zynq-7000 SoC includes a factory-programmed boot ROM that is not user accessible. The boot ROM determines whether the boot is secure or non-secure, performs some initialization of the system and clean-ups, reads the mode pins to determine the primary boot device and finishes once it is satisfied it can execute the FSBL.

After a system reset, the system automatically sequences to initialize the system and process the first stage boot loader from the selected external boot device. The process enables you to configure the SoC platform as needed, including the PS and the PL. Optionally, the JTAG interface can be enabled to give the design engineer access to the PS and the PL for test and debug purposes.

Power to the PL can be optionally shut off to reduce power consumption. In addition, the clocks in the PS can be dynamically slowed down or gated off to reduce power further. Zynq-7000 SoC devices support the Arm standby mode to obtain minimal power drain, but still are able to start up when certain events occur.

Elements of the Zynq-7000 SoC are described from the point of view of the PS. For example, a general purpose slave interface on the PS to the PL means that the master resides in the PL. A high performance slave interface means the high performance master resides in the PL. A general purpose master interface means the PS is the master and the slave resides in the PL.

1.1.3 Notices

Zynq-7000 SoC Device Family

The PS structure for all Zynq-7000 SoC devices is the same except for the following:

7z007s and 7z010 CLG225 Devices

The 7z007s single core and 7z010 dual core CLG225 devices have a limited number of pins (225). This reduces the capability of the MIO, DDR and XADC subsystems.

- 32 MIO pins, see section [2.5.3 MIO Pin Assignment Considerations](#)
- 16 DDR data, see section [10.1.3 Notices](#) in [Chapter 10, DDR Memory Controller](#)
- Four pairs of XADC signals, see [Notices](#) in [Chapter 30, XADC Interface](#)

Device Revisions

The visual markings are shown in [UG865, Zynq-7000 SoC Packaging and Pinout Advance Product Specification](#).

Software can read the following registers in all Zynq-7000 SoC devices to determine silicon revision:

- devcfg.MCTRL [PS_VERSION]
- slcr.PSS_IDCODE[IDCODE]

The JTAG interface also includes the IDCODE revision content.

TrustZone Capabilities

TrustZone is hardware that is built into all Zynq-7000 SoC devices. For more information, see [UG1019, Programming ARM TrustZone Architecture on the Xilinx Zynq-7000 SoC](#).

1.2 Processing System (PS) Features and Descriptions

1.2.1 Application Processor Unit (APU)

The application processor unit (APU) provides an extensive offering of high-performance features and standards-compliant capabilities.

Dual/Single Arm Cortex-A9 MPCore CPUs with Arm v7

- Run time options allow single processor, asymmetrical (AMP) or symmetrical multiprocessing (SMP) configurations
- Arm version 7 ISA: standard Arm instruction set and Thumb®-2, Jazelle® RCT and Jazelle DBX Java™ acceleration
- NEON™ 128b SIMD coprocessor and VFPv3 per MPCore
- 32 KB instruction and 32 KB data L1 caches with parity per MPCore
- 512 KB of shareable L2 cache with parity
- Private timers and watchdog timers

System Features

- System-Level Control Registers (SLCRs)
 - A group of various registers that are used to control the PS behavior
 - The register map is located in [Chapter 4, System Addresses](#)
 - The SLCR registers related to a specific chapter are listed in the register overview table of that chapter and detailed in [Appendix B, Register Details](#)
- Snoop control unit (SCU) to maintain L1 and L2 coherency
- Accelerator coherency port (ACP) from PL (master) to PS (slave)
 - 64b AXI slave port
 - Can access the L2 and the OCM
 - Transactions are data coherent with L1 and L2 caches
- 256 KB of on-chip SRAM (OCM) with parity
 - Dual ported
 - Accessible by the CPUs, PL and central interconnect
 - At level of L2, but is not cacheable
- DMA controller
 - Four channels for PS (memory copy to/from any memory in system)
 - Four channels for PL (memory to PL, PL to memory)

- General interrupt controller (GIC)
 - Individual interrupt masks and interrupt prioritization
 - Five CPU-private peripheral interrupts (PPI)
 - Sixteen CPU-private software generated interrupts (SGI)
 - Distributes shared peripheral interrupts (SPI) from the rest of the system, PS and PL
 - 20 from the PL
 - Wait for interrupt (WFI) and wait for event (WFE) signals from CPU sent to PL
 - Enhanced security features to support TrustZone™ technology
- Watchdog timer, triple counter/timer

1.2.2 Memory Interfaces

The memory interfaces includes multiple memory technologies.

DDR Controller

- Supports DDR3, DDR3L, DDR2, LPDDR-2
 - Rate is determined by speed and temperature grade of the device
- 16b or 32b wide
 - ECC on 16b
- Uses up to 73 dedicated PS pins
- Modules (no DIMMs)
 - 32b wide: 4 x 8b, 2 x 16b, 1 x 32b
 - 16b wide: 2 x 8b, 1 x 16b
- Autonomous DDR power down entry and exit based on programmable idle periods
- Data read strobe auto-calibration
- Write data byte enables supported for each data beat
- Low latency read mechanism using HPR queue
- Special urgent signaling to each port
- TrustZone regions programmable on 64 MB boundaries
- Exclusive accesses for two different IDs per port (locked transactions are not supported)

DDR Controller Core and Transaction Scheduler

- Transaction scheduling is done to optimize data bandwidth and latency
- Advanced re-ordering engine to maximize memory access efficiency with target of 90% efficiency with continuous read and write and 80% efficiency with random read and write
- Write-read address collision checking that flushes the write buffer
- Obeys AXI ordering rules

Quad-SPI Controller

Key features of the linear Quad-SPI controller (which can be a primary boot device) are:

- Single or dual
- 1x and 2x read support
- 32-bit APB 3.0 interface for I/O mode that allows full device operations including program, read and configuration
- 32-bit AXI linear address mapping interface for read operations
- Single device select line support
- Supports write protection signal
- 4-bit bidirectional I/O signals
- Read speed of x1, x2 and x4
- Write speed of x1 and x4
- Maximum Quad-SPI clock at master mode is 100 MHz
- 252-byte entry FIFO depth to improve Quad-SPI read efficiency
- Supports Quad-SPI device up to 128 Mb density in I/O and linear mode. >128Mb devices are supported in IO mode only.
- Supports dual Quad-SPI with two quad-SPI devices in parallel

In addition, the linear address mapping mode features include:

- Supports regular read-only memory access through the AXI interface
- Up to two SPI flash memories
- Up to 16 MB addressing space for one memory and 32 MB for two memories in linear mode
- AXI read acceptance capability of 4
- Both AXI incrementing and wrapping-address burst read
- Automatically converts normal memory read operation to SPI protocol, and vice versa
- Serial, Dual and Quad-SPI modes

Static Memory Controller (SMC)

Either of the following can be the primary boot device:

- NAND controller
 - 8/16-bit I/O width with one chip select signal
 - ONFI specification 1.0
 - 16-word read and 16-word write data FIFOs
 - 8-word command FIFO
 - Programmable I/O cycle timing
 - ECC assist
 - Asynchronous memory operating mode

- Parallel SRAM/NOR controller
 - 8-bit data bus width
 - One chip select with up to 25 address signals (32 MB)
 - Two chip selects with up to 25 address signals (32 MB + 32 MB)
 - 16-word read and 16-word write data FIFOs
 - 8-word command FIFO
 - Programmable I/O cycle timing on a per chip select basis
 - Asynchronous memory operating mode

1.2.3 I/O Peripherals

The I/O Peripherals (IOP) are a collection of industry-standard interfaces for external data communication.

Note: The controller registers require single 32-bit read/write accesses, do not use byte, halfword, or double word references.

GPIO

- Up to 54 GPIO signals for device pins routed through the MIO
 - Outputs are 3-state capable
- 192 GPIO signals between the PS and PL via the EMIO
 - 64 Inputs, 128 outputs (64 true outputs and 64 output enables)
- The function of each GPIO can be dynamically programmed on an individual or group basis
 - Enable, bit or bank data write, output enable and direction controls
- Programmable Interrupts on individual GPIO basis
 - Status read of raw and masked interrupt
 - Positive edge, negative edge, either edge, high level, low level sensitivities

Gigabit Ethernet Controllers (Two)

- RGMII interface using MIO pins and external PHY
- Additional interface using PL SelectIO and external PHY with additional soft IP in the PL
- SGMII interface using PL GTP or GTX transceivers
- Built-in DMA with scatter-gather
- IEEE 802.3-2008
- Wake-on capability

USB Controllers: Each as Host, Device or OTG (Two)

- USB 2.0 high speed on-the-go (OTG) dual role USB host controller or USB device controller operation using the same hardware
- MIO pins only (one USB controller is available in the 7x010 device)
- Built-in DMA
- USB 2.0 high speed device
- USB 2.0 high speed host controller
- The USB host controller registers and data structures are EHCI compatible
- Direct support for USB transceiver low pin interface (ULPI). The ULPI module supports 8 bits
- External PHY required
- Support up to 12 endpoints

SD/SDIO Controllers (Two)

- Bootable SD Card mode (option)
- Built-in DMA
- Host mode support only
- Support for version 2.0 of SD specification
- Full speed and low speed support
- 1-bit and 4-bit data interface support
- Low speed clock 0–400 kHz
- Support for high speed interface
- Full speed clock 0-50 MHz with maximum throughput at 25 MB/s
- Support for memory, I/O, and combination cards
- Support for power control modes
- Support for interrupts
- 1 KB Data FIFO interface

SPI Controllers (Two): Master or Slave

- Four wire bus: MOSI, MISO, SCLK, SS
- Full-duplex operation offers simultaneous receive and transmit
- Master mode
 - Manual or auto start transmission of data
 - Manual or auto slave select (SS) mode
 - Supports up to three slave select lines
 - Allows the use of an external peripheral select 3-to-8 decode
 - Programmable delays for data transmission

- Slave mode
 - Programmable start detection mode
- Multi-master environment
 - Drives into 3-state if not enabled
 - Identifies an error condition if more than one master detected
- Supports 50 MHz maximum external SPI clock rate through MIO
 - 25 MHz maximum through EMIO to PL SelectIO pins
- Selectable master clock reference
- Programmable master baud rate divisor
- Supports 128-byte read and 128-byte write FIFOs
 - Each FIFO is 8-bit wide
- Programmable FIFO thresholds
- Supports programmable clock phase and polarity
- Supports manual or auto start transmission of data
- Software can poll for status or function as interrupt-driven
- Programmable interrupt generation

CAN Controllers (Two)

- Conforms to the ISO 11898 -1, CAN 2.0A, and CAN 2.0B standards
- Supports both standard (11-bit identifier) and extended (29-bit identifier) frames
- Supports bit rates up to 1 Mb/s
- Transmit message FIFO with a depth of 64 messages
- Transmit prioritization through one high-priority transmit buffer
- Support of watermark interrupts for TxFIFO and RxFIFO
- Automatic re-transmission on errors or arbitration loss in normal mode
- Receive message FIFO with a depth of 64 messages
- Acceptance filtering of four acceptance filters
- Sleep mode with automatic wake-up
- Snoop mode
- Loopback mode for diagnostic applications
- Maskable error and status interrupts
- 16-bit time stamping for receive messages
- Readable error counters

UART Controllers (Two)

- Programmable baud rate generator

- 64-byte receive and transmit FIFOs
- 6, 7, or 8 data bits
- 1, 1.5, or 2 stop bits
- Odd, even, space, mark, or no parity
- Parity, framing and overrun error detection
- Line-break generation and detection
- Automatic echo, local loopback, and remote loopback channel modes
- Interrupts generation
- Rx and Tx signals are on the MIO and EMIO interfaces
- Modem control signals: CTS, RTS, DSR, DTR, RI, and DCD are available on the EMIO interface

I2C Controllers (two)

- Supports 16-byte FIFO
- I2C bus specification version 2
- Programmable normal and fast bus data rates
- Master mode
 - Write transfer
 - Read transfer
 - Extended address support
 - Support HOLD for slow processor service
 - Supports TO interrupt flag to avoid stall condition
- Slave monitor mode
- Slave mode
 - Slave transmitter
 - Slave receiver
 - Extended address support
 - Fully programmable slave response address
 - Supports HOLD to prevent overflow condition
 - Supports TO interrupt flag to avoid stall condition
- Software can poll for status or function as interrupt-driven device
- Programmable interrupt generation

PS MIO I/Os

The PS MIO I/O buffers are split into two voltage domains. Within each domain, each MIO is independently programmable.

- Two I/O voltage banks
 - Bank 0 voltage bank consists of pins 0:15

- Bank 1 voltage bank consists of pins 16:53
- MIO voltage levels can be programmed per bank.
 - 1.8 and 2.5/3.3 volts
 - CMOS single ended or HSTL differential receiver mode

1.3 Programmable Logic Features and Descriptions

The PL provides a rich architecture of user-configurable capabilities.

- Configurable logic blocks (CLB)
 - 6-input look-up tables (LUTs)
 - Memory capability within the LUT
 - Register and shift register functionality
 - Cascadeable adders
- 36 Kb block RAM
 - Dual port
 - Up to 72-bits wide
 - Configurable as dual 18 Kb
 - Programmable FIFO logic
 - Built-in error correction circuitry
- Digital signal processing — DSP48E1 Slice
 - 25 × 18 two's complement multiplier/accumulator high-resolution (48 bit) signal processor
 - Power saving 25-bit pre-adder to optimize symmetrical filter applications
 - Advanced features: optional pipelining, optional ALU, and dedicated buses for cascading
- Clock management
 - High-speed buffers and routing for low-skew clock distribution
 - Frequency synthesis and phase shifting
 - Low-jitter clock generation and jitter filtering
- Configurable I/Os
 - High-performance SelectIO technology
 - High-frequency decoupling capacitors within the package for enhanced signal integrity
 - Digitally controlled impedance that can be 3-stated for lowest power, high-speed I/O operation
 - High range (HR) I/Os support 1.2V to 3.3V
 - High performance (HP) I/Os support 1.2V to 1.8V (7z030, 7z035, 7z045, and 7z100 devices)
- Low-power gigabit transceivers (7z012s, 7z015, 7z030, 7z035, 7z045, and 7z100 devices)

- High-performance transceivers capable of up to 12.5 Gb/s (GTX) in 7z030, 7z035, 7z045 and 7z100 devices
- High-performance transceivers capable of up to 6.25 Gb/s (GTP) in 7z012s and 7z015 devices
- Low-power mode optimized for chip-to-chip interfaces
- Advanced transmit pre- and post-emphasis, and receiver linear (CTLE) and decision feedback equalization (DFE), including adaptive equalization for additional margin
- Analog-to-digital converter (XADC)
 - Dual 12-bit 1 MSPS analog-to-digital converters (ADCs)
 - Up to 17 flexible and user-configurable analog inputs
 - On-chip or external reference option
 - On-chip temperature and power supply sensors
 - Continuous JTAG access to ADC measurements
- Integrated interface blocks for PCI Express designs (7z015, 7z030, 7z035, 7z045, and 7z100 devices)
 - Compatible to the PCI Express base specification 2.1 with Endpoint and Root Port capability
 - Supports Gen1 (2.5 Gb/s) and Gen2 (5.0 Gb/s) speeds
 - Advanced configuration options, advanced error reporting (AER), and end-to-end CRC (ECRC) advanced error reporting and ECRC features

1.4 Interconnect Features and Description

Zynq-7000 SoC devices uses several interconnect technologies, optimized to the specific communication needs of the functional blocks. For more information, refer to the block diagram in [Figure 1-1](#) or a more detailed diagram in [Figure 5-1](#).

1.4.1 PS Interconnect Based on AXI High Performance Datapath Switches

- OCM interconnect
 - Provides access to the 256 KB memory from the central interconnect and the PL
 - CPUs and ACP interfaces have the lowest latency access to OCM through the SCU
- Central interconnect
 - The central interconnect is 64 bits, connecting the IOP and DMA controller to the DDR memory controller, on-chip RAM, and the AXI_GP interfaces (through their switches) for the PL logic
 - Connects the local DMA units in the Ethernet, USB and SD/SDIO controllers to the central interconnect
 - Connects masters in the PS to the IOP

1.4.2 PS-PL Interfaces

The PS-PL interface contains all the signals available to the PL designer for integrating the PL-based functions and the PS. There are two types of interfaces between the PL and the PS.

1. Functional interfaces which include AXI interconnect, extended MIO interfaces (EMIO) for most of the I/O peripherals, interrupts, DMA flow control, clocks, and debug interfaces. These signals are available for connecting with user-designed IP blocks in the PL.
2. Configuration signals which include the processor configuration access port (PCAP), configuration status, single event upset (SEU) and Program/Done/Init. These signals are connected to fixed logic within the PL configuration block, providing PS control.

AXI functional interfaces:

- AXI_ACP
 - One 64-bit cache coherent slave port in the APU interfaces to a PL master port
 - Connects to the snoop control unit for cache coherency between the CPUs and the PL
- AXI_HP, four high performance/bandwidth master ports on the PS AXI interconnect
 - 32-bit or 64-bit data master interfaces (independently programmed)
 - Efficient resizing in 32-bit slave interface configuration mode
 - Efficient upsizing to 64-bits for aligned 32-bit transfers in 32-bit slave interface configuration mode
 - Automatic expansion to 64 bits for unaligned 32-bit transfers in 32-bit slave interface configuration mode
 - Dynamic command upsizing translation between 32-bit and 64-bit interfaces, controllable through AxCACHE[1]
 - Separate R/W programmable issuing capability for read and write commands
 - Programmable release threshold of write commands
 - Asynchronous clock frequency domain crossing for all AXI interfaces between the PL and PS
 - Smoothing out of “long-latency” transfers using 1 KB (128 by 64 bits) data FIFOs for both reads and writes
 - QoS signaling available from PL ports
 - Command and data FIFO fill-level counts available to the PL
 - Standard AXI 3.0 interfaces supported
 - Large slave interface read acceptance capability in the range of 14 to 70 commands (burst length dependent)
 - Large slave interface write acceptance capability in the range of 8 to 32 commands (burst length dependent)
- AXI_GP, four general purpose ports
 - Two, 32-bit master interfaces
 - Two, 32-bit slave interfaces
 - Asynchronous clock frequency domain crossing for all AXI interfaces between the PL and PS
 - Standard AXI 3.0 interfaces supported

1.5 System Software

Xilinx provides device drivers for all of the I/O peripherals. These device drivers are provided in source format and support bare-metal or stand-alone and Linux. An example first-stage boot loader (FSBL) is also provided in source code format. The source drivers for stand-alone and FSBL are provided as part of the Xilinx IDE Design Suite Embedded Edition. The Linux drivers are provided through the Xilinx Open Source Wiki at wiki.xilinx.com

Refer to [UG821](#), *Zynq-7000 Software Developers Guide* for additional information.

In addition, Xilinx Alliance Program partners provide system software solutions for IP, middleware, operation systems, etc. Refer to the Zynq-7000 landing page at www.xilinx.com/zynq for the latest information.

Signals, Interfaces, and Pins

2.1 Introduction

This chapter identifies the user visible signals and interfaces in Zynq-7000 SoC devices. The interfaces and signals are organized into major groups as shown in [Figure 2-1](#). The Zynq-7000 SoC devices consist of a Processing System (PS) with a Xilinx Artix™-7 or Kintex™-7 based Programmable Logic (PL) block.

2.1.1 Notices

7z007s and 7z010 CLG225 Devices

The 7z007s single core and 7z010 dual core CLG225 devices (225 pin packages) support 32 MIO pins and at most one Ethernet interface through the MIO pins. This is shown in the MIO table in [2.5.4 MIO-at-a-Glance Table](#). One or both of the Ethernet controllers can interface to logic in the PL.

PS-PL Voltage Level Shifters

All of the signals and interfaces that go between the PS and PL traverse a voltage boundary. These input and output signals are routed through voltage level shifters that must be enabled and disabled during the power-up and power-down sequences of the PL. For more information on the voltage level shifters, refer to section [2.4 PS-PL Voltage Level Shifter Enables](#).

Pin Timing and Voltage Specifications

Refer to the Zynq-7000 SoC Data Sheet for timing and pin voltage information.

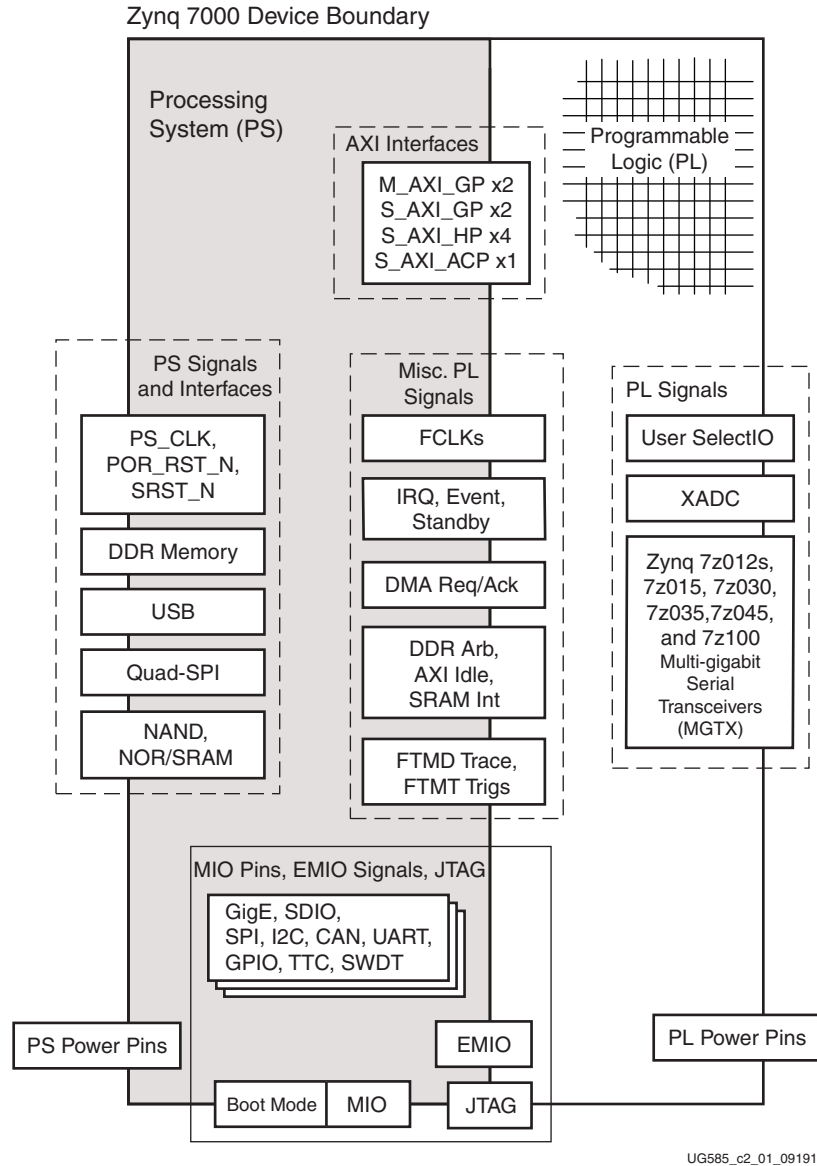

Figure 2-1: Signals, Interfaces, and Pins

2.2 Power Pins

The PS and PL power supplies are fully independent, however the PS power supply must be present whenever the PL power supply is active. PL power up needs to maintain a certain timing relationship with the POR reset signal of the PS. For more details refer to section [6.3.3 BootROM Performance: PS_POR_B De-assertion Guidelines](#), page 179.

The PS includes an independent power supply for the DDR I/O and two independent voltage banks for MIO. The power pins are summarized in [Table 2-1](#). The voltage sequencing and electrical specifications are shown in the applicable Zynq-7000 SoC data sheet. Also refer to the Zynq-7000 SoC packaging and pin documents for more information.

Table 2-1: Power Pins

| Type | Pin Name | Nominal Voltage | Power Pin Description |
|----------|--|-----------------|---------------------------------|
| PS Power | V _{CCPINT} | 1.0V | Internal logic |
| | V _{CCPAUX} | 1.8V | I/O buffer pre-driver |
| | V _{CCO_DDR} | 1.2V to 1.8V | DDR memory interface |
| | V _{CCO_MIO0} | 1.8V to 3.3V | MIO bank 0, pins 0:15 |
| | V _{CCO_MIO1} | 1.8V to 3.3V | MIO bank 1, pins 16:53 |
| | V _{CCPLL} | 1.8V | Three PLL clocks, analog |
| PL Power | V _{CCINT} | 1.0V | Internal core logic |
| | V _{CCAUX} | 1.8V | I/O buffer pre-driver |
| | V _{CCO_#} | 1.2V to 3.3V | I/O buffers drivers (per bank) |
| | V _{CC_BATT} | 1.5V | PL decryption key memory backup |
| | V _{CCBRAM} | 1.0V | PL block RAM |
| | V _{CCAUX_IO_G#} | 1.8V to 2.0V | PL auxiliary I/O circuits |
| XADC | V _{CCADC} , G _{NDADC} | N/A | Analog power and ground. |
| Ground | GND | Ground | Digital and analog grounds |

Note: Refer to the respective data sheet for recommended operating conditions.

2.3 PS I/O Pins

A summary of the dedicated PS signal pins is shown in [Table 2-2](#).



CAUTION! For MIO pins, the allowable *V_{in} High* level voltage depends on the settings of the *slcr.MIO_PIN_xx [IO_Type]* and *[DisableRcvr]* bits. These restrictions and the restrictions for all I/O pins are defined in the Zynq-7000 SoC data sheets. Damage to the input buffer can occur when the limits are exceeded.

Table 2-2: PS Signal Pins

| Group | Name | Type | Zynq-7000 Family Pin Count ⁽¹⁾ | 7z007s/7z010 Device Pin Count | Voltage Node | Description |
|-------|----------------|------|---|-------------------------------|-----------------------|--|
| Clock | PS_CLK | I | 1 | 1 | V _{CCO_MIO0} | System reference clock. See Chapter 25, Clocks . |
| Reset | PS_POR_B | I | 1 | 1 | V _{CCO_MIO0} | Power on reset, active low. See Chapter 26, Reset System . |
| | PS_SRST_B | I | 1 | 1 | V _{CCO_MIO1} | Debug system reset, active Low. Forces the system to enter a reset sequence. See Chapter 26, Reset System . |
| MIO | PS_MIO[15:0] | I/O | 16 | 16 | V _{CCO_MIO0} | Refer to section 2.5 PS-PL MIO-EMIO Signals and Interfaces and UG865, Zynq-7000 SoC Package and Pinout Guide . |
| | PS_MIO[53:16] | I/O | 38 | 16 | V _{CCO_MIO1} | |
| | PS_MIO_VREF | Ref | 1 | 0 | V _{CCO_MIO1} | Voltage reference for RGMII input receivers, refer to UG933, Zynq-7000 SoC PCB Design and Pin Planning Guide . |
| DDR | PS_DDR_xxx | I/O | 73 | 51 | V _{CCO_DDR} | See Chapter 10, DDR Memory Controller . |
| | PS_DDR_VR[N,P] | N/A | 2 | 1 | ~ | DDR DCI voltage reference pins, refer to UG933, Zynq-7000 SoC PCB Design and Pin Planning Guide . |
| | PS_DDR_VREF | Ref | 4 | 4 | ~ | Voltage reference for DDR DQ and DQS differential input receivers, refer to UG933, Zynq-7000 SoC PCB Design and Pin Planning Guide . |

Notes:

- Does not include 7z007s single core and 7z010 dual core CLG225 devices.

7z007s and 7z010 Devices

The 7z007s single core and 7z010 dual core CLG225 devices (225 pin packages) have fewer pins than the other Zynq-7000 SoC devices (see [Table 2-2](#)). Details for DDR and MIO pins can be found in [Chapter 10, DDR Memory Controller](#) and section [2.5.3 MIO Pin Assignment Considerations](#), respectively. There is more information about the CLG225 devices in section [1.1.3 Notices](#).

2.4 PS–PL Voltage Level Shifter Enables

All of the signals and interfaces that go between the PS and PL traverse a voltage boundary. These input and output signals are routed through voltage level shifters. The majority of the voltage level shifters are enabled by the `slcr.LVL_SHFTR_EN` register. The voltage level shifter enables for some PS-PL traversing signals are controlled with the PL power state. These include signals for the XADC, PL, and EMIO JTAGs; the PCAP interface; and other modules.

The enabling and disabling of the voltage level shifters must be managed during the PL power-up and power-down sequences to avoid extraneous logic level transitions on the input signals to the PS modules. Disable the voltage level shifters before the PL is powered down. Similarly, enable the level shifters after the PL is powered up and before the signals are used. The PS must be powered on to program the logic in the PL.

Example: Power-up Sequence

1. **Power-up the PL.** Refer to the data sheet for voltage sequencing requirements. The `slcr.LVL_SHFTR_EN` register should be equal to `0x0`.
2. **Enable the PS-to-PL level shifters.** Write `0x0A` to the `slcr.LVL_SHFTR_EN` register.
3. **Program the PL.**
4. **Wait for the PL to be programmed.** Read `devcfg.INT_STS [PCFG_DONE_INT]` until = 1 to indicate that the DONE signals has asserted.
5. **Enable the PL-to-PS level shifters.** Write `0x0F` to the `slcr.LVL_SHFTR_EN` register.
6. **Begin to use the signals and interfaces between the PS and PL.**

Example: Power-down Sequence

1. **Stop using the signals and interfaces between the PS and PL.**
2. **Disable the voltage level shifters.** Write `0x0` to the `slcr.LVL_SHFTR_EN` register.
3. **Power-down the PL.** Refer to the data sheet for voltage sequencing requirements.
4. **Leave the `slcr.LVL_SHFTR_EN` register = `0x0` when the PL is powered down.**



TIP: Functionally, there is no reason to enable the voltage level shifters until the PL is fully configured. The PS does not allow the voltage level shifters to be enabled until the PL global signals indicate that it is safe to do so. The PL is fully programmed when the PL DONE signal is High. The PL DONE signal is tracked as an interrupt in the DevC subsystem.

2.5 PS-PL MIO-EMIO Signals and Interfaces

The MIO is fundamental to the I/O peripheral connections due to the limited number of MIO pins. Software programs the routing of the I/O signals to the MIO pins. The I/O peripheral signals can also be routed to the PL (including PL device pins) through the EMIO interface. This is useful to gain access to more device pins (PL pins) and to allow an I/O peripheral controller to interface to user logic in the PL. See [Figure 2-2](#).

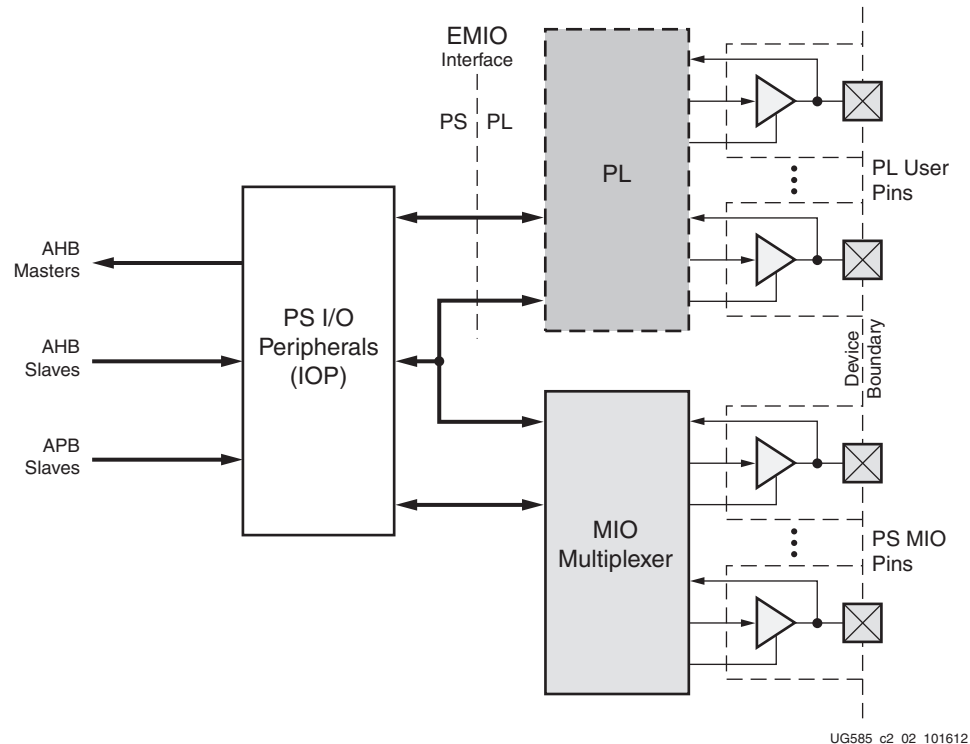

Figure 2-2: MIO-EMIO Overview

2.5.1 I/O Peripheral (IOP) Interface Routing

The I/O multiplexing of the I/O controller signals differs; that is, some IOP signals are solely available on the MIO pin interface, some signals are available via MIO or EMIO, and some of the interface signals are only accessible via EMIO. Some of the routing capabilities for each IOP peripheral are shown in [Table 2-3](#). The details for each IOP are included in the chapter that describes the IOP. MIO pin assignment possibilities are illustrated in section [2.5.4 MIO-at-a-Glance Table](#).

Note: The routing of the IOP interface I/O signals must be done as a group; that is, the signals must not be split and routed to different MIO pin groups. For example, if the SPI 0 CLK is routed to MIO pin 40, then the other signals of the SPI 0 interface must be routed to MIO pins 41 to 45. Similarly, the signals within an IOP interface must not be split between MIO and EMIO. However, unused signals within an IOP interface do not necessarily need to be routed. Unused signals can be configured as a GPIO.

Table 2-3: I/O Peripheral MIO-EMIO Interface Routing

| Peripheral | MIO Routing | EMIO Routing | Cross Reference |
|----------------|---|---|--|
| TTC [0,1] | Clock In, Wave Out. One pair of signals from each counter. | Clock In, Wave Out. Three pairs of signals from each counter. | See Chapter 8, Timers |
| SWDT | Clock In, Reset Out | Clock In, Reset Out | See Chapter 8, Timers |
| SMC | Parallel NOR/SRAM and NAND Flash | Not available | See Chapter 11, Static Memory Controller |
| Quad-SPI [0,1] | Serial, dual and quad modes | Not available | See Chapter 12, Quad-SPI Flash Controller |
| SDIO [0,1] | 50 MHz | 25 MHz | See Chapter 13, SD/SDIO Controller |
| GPIOs | Up to 54 I/O channels (GPIO Banks 0 and 1) | 64 GPIO channels with input, output, 3-state control (GPIO banks 2 and 3) | See Chapter 14, General Purpose I/O (GPIO) |
| USB [0,1] | Host, device, and OTG | Not available | See Chapter 15, USB Host, Device, and OTG Controller |
| Ethernet [0,1] | RGMII v2.0 | MII/GMII ⁽¹⁾ | See Chapter 16, Gigabit Ethernet Controller |
| SPI [0,1] | 50 MHz | Available | See Chapter 17, SPI Controller |
| CAN [0,1] | ISO 11898 -1, CAN 2.0A/B | Available | See Chapter 18, CAN Controller |
| UART [0,1] | Simple UART: Two pins (TX/RX) | TX, RX, DTR, DCD, DSR, RI, RTS and CTS | See Chapter 19, UART Controller |
| I2C [0,1] | SCL, SDA {0, 1} | SCL, SDA {0, 1} | See Chapter 20, I2C Controller |
| PJTAG | TCK, TMS, TDI, TDO | TCK, TMS, TDI, TDO, 3-state for TDO | See Chapter 27, JTAG and DAP Subsystem |
| Trace Port IU | Up to 16-bit data | Up to 32-bit data | See Chapter 28, System Test and Debug |

Notes:

1. When the Ethernet MII/GMII interface is routed through EMIO, other MII interfaces (e.g., RMII, RGMII, and SGMII) can be derived using appropriate shim logic in the PL that attaches to PL pins.

2.5.2 IOP Interface Connections

For most peripherals, there is flexibility in where the I/O signals can be mapped. The routing capabilities are shown in [Figure 2-4](#). For example, the XPS design software includes up to 12 possible MIO port mappings for CAN, or, if selected, a path to the EMIO interface. The peripheral system connection diagram is shown in [Figure 2-3](#).

The majority of the I/O signals for PS peripherals, other than USB, can be routed to either the PS pins through the MIO, or to the PL pins through the EMIO. Most peripherals also maintain the same protocol between MIO and EMIO, except Gigabit Ethernet. To reduce pin count, a 4-bit RGMII interface runs through the MIO at a 250 MHz data rate (125 MHz clock with a double data rate). The route through the EMIO includes an 8-bit GMII interface running at a 125 MHz data rate. The USB, Quad-SPI, and SMC interfaces are not available to the EMIO interface to the PL.

On the interconnect side, the USB, Ethernet and SDIO peripherals are connected to the central interconnect to service the six DMA masters. Software accesses the slave-only Quad-SPI and SMC peripherals via the AHB interconnect. The GPIO, SPI, CAN, UART, and I2C slave-only controllers are accessed via the APB bus. All control and status registers are also accessed via the APB interconnect except for the SDIO controllers which each have two AHB interfaces. This architecture is designed to balance the bandwidth needs of each controller interface.

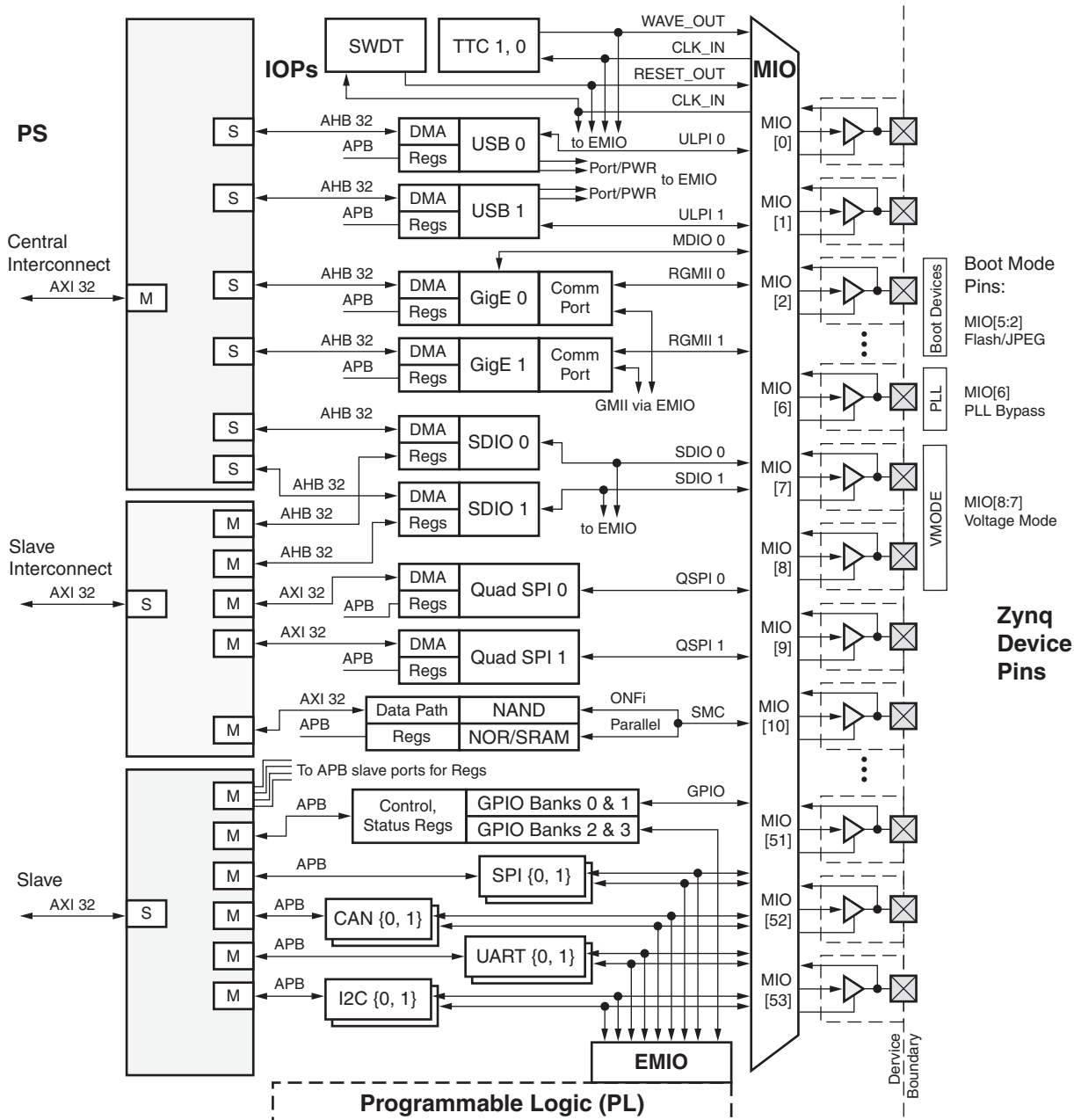

UG585_c2_03_121613

Figure 2-3: I/O Peripherals System Diagram

2.5.3 MIO Pin Assignment Considerations

Normally, each pin is assigned to one function. One exception to this is the dual use boot mode strapping resistors (MIO [2:8]).



IMPORTANT: *There are several important MIO pin assignment considerations. The MIO-at-a-Glance table, the interface routing table, and these pin assignment considerations are helpful when doing pin planning.*

Interface Frequencies: The clocking frequency for an interface usually depends on device speed grade and whether the interface is routed via MIO or EMIO. The possible routing paths for each interface are listed in [Table 2-3, page 49](#). The maximum clock frequency that can be used for each speed grade and routing path are defined in the Zynq-7000 SoC data sheets.

Two MIO Voltage Banks: The MIO pins are split across two independently configured sets of I/O buffers: Bank 0, MIO[15:0] and Bank 1, MIO[53:16]. The signalling voltage is initially configured using the VMODE boot mode strapping pins. Each bank can be configured for 1.8V signalling or 2.5V/3.3V.

Boot Mode Strapping Pins: These pins can be assigned to I/O peripherals in addition to functioning as boot mode pins. MIO pins [8:2], define the boot device, the initial PLL clock bypass mode, and the voltage mode (VMODE) for the MIO banks. The strapping pins are sampled a few PS_CLK clock cycles after the PS_POR_B reset signal de-asserts. The board design ties these signals to VCC or ground using 20 K Ω pull-up and pull-down resistors. More information about the boot mode pin settings is provided in [Chapter 6, Boot and Configuration](#).

I/O Buffer Output Enable Control: The output enable for each MIO I/O buffer is controlled by a combination of the setting of the three-state override control bit, the selected signal type (input-only or not), and the state of the peripheral controller. The three-state override bit can be controlled from either of two places: the slcr.MIO_PIN_xx [TRI_ENABLE] register bit or the slcr.MIO_MST_TRI register bits. These bits control the same flip-flop to help control the three-state signal of the I/O buffer. The I/O buffer output is enabled when the three-state override control bit = 0 and either the signal is an output-only or the I/O peripheral desires to drive a signal that is configured as I/O.

Boot from SD Card: The BootROM expects the SD card to be connected to MIO pins 40 through 45 (SDIO 0 interface).

Static Memory Controller (SMC) Interface: Only one SMC memory interface can be used in a design. The SMC controller consumes many of the MIO pins and neither of the SMC memory interfaces can be routed to the EMIO.

For example, if an 8-bit NAND Flash is implemented, then Quad-SPI, is not available and the test port is limited to 8-bits. If a 16-bit NAND Flash is implemented, then additional pins are consumed. Ethernet 0 is not available. The SRAM/NOR interface consumes up to 70% of the MIO pins, eliminating Ethernet and USB 0.

The SRAM/NOR upper address pins are optional, as appropriate for the attached device. Also note that the SMC interface straddles the two MIO voltage banks.

Quad-SPI Interface: The lower memory Quad-SPI interface (QSPI_0) must be used if the Quad-SPI memory subsystem is to be used. The upper interface (QSPI_1) is optional and is only used for a two-memory arrangement (parallel or stacked). Do not use the Quad-SPI 1 interface alone.

MIO Pins [8:7] are Outputs: These MIO pins are available as output only. GPIO channels 7 and 8 can only be configured as outputs.

MIO Pins in 7z007s and 7z010 CLG225 Devices: 7z010 dual core and 7z007s single core CLG225 devices have 32 MIO pins, 0:15, 28:39, 48, 49, 52, and 53. All other Zynq-7000 SoC devices include all 54 MIO pins and all devices have the same EMIO interface functionality. Refer to section [1.1.3 Notices](#).

The 32 MIO pins available in the 7z007s and 7z010 devices restrict the functionality of the PS:

- Either one USB or one Ethernet controller via MIO
- No boot from SD Card
- No NOR/SRAM interfacing
- Width of NAND Flash limited to 8 bits

2.5.4 MIO-at-a-Glance Table

Table 2-4 presents MIO information in a compact format for easy reference; the gray boxes represent signals that are not usable in devices with CLG225 packages (7z010 dual core and 7z007s single core devices). Refer to section [PS-PL MIO-EMIO Signals and Interfaces](#) for background information. This section also includes important pin assignment considerations. GPIOs are available for each MIO pin. Pins 0–31 are controlled by GPIO bank 0. Pins 32–53 are controlled by GPIO bank 1. MIO7 and MIO8 can only be used as outputs.

Table 2-4: MIO-at-a-Glance

| MIO Voltage Bank 0 Package Bank 500 | | | | | | | | | | MIO Voltage Bank 1 Package Bank 501 | | | | | | | | | | | | | | | | | | | | | | | | | | | | | | | | | | | | | | | | | | | |
|---|---|--|---|-----------------------|---|---------|---|--------------|---|---|----|------------|----|-------------------|----|---------|----|--------------|----|---|----|-------|----|----------------------------------|----|--------|----|---|----|---|----|----------------------------------|----|-------|----|-------|----|-------|----|-------|----|-------|----|-------|----|-------|----|-------|----|----|----|------|----|
| 0 | 1 | 2 | 3 | 4 | 5 | 6 | 7 | 8 | 9 | 10 | 11 | 12 | 13 | 14 | 15 | 16 | 17 | 18 | 19 | 20 | 21 | 22 | 23 | 24 | 25 | 26 | 27 | 28 | 29 | 30 | 31 | 32 | 33 | 34 | 35 | 36 | 37 | 38 | 39 | 40 | 41 | 42 | 43 | 44 | 45 | 46 | 47 | 48 | 49 | 50 | 51 | 52 | 53 |
| | | | | | | | | | | Pins not available in 7z010 and 7z007s CLG225 devices | | | | | | | | | | | | | | | | | | Pins not available in 7z010 and 7z007s CLG225 devices | | | | | | | | | | | | | | | | | | | | | | | | | |
| BOOT_MODE | | The 20k ohm Boot Mode pull-up/down resistors are sampled at Reset. | | Ethernet 0 | | | | | | | | | | Ethernet 1 | | | | | | | | | | MDIO | | | | | | | | | | | | | | | | | | | | | | | | | | | | | |
| Device | | pll V | | tx ck | | tx data | | rx ctl | | rx ck | | rx data | | rx ctl | | tx ck | | tx data | | rx ctl | | rx ck | | rx data | | rx ctl | | ck | | d | | | | | | | | | | | | | | | | | | | | | | | |
| Quad SPI 0 | | | | Quad SPI 1 | | | | USB 0 | | | | | | | | | | USB 1 | | | | | | | | | | | | | | | | | | | | | | | | | | | | | | | | | | | |
| cs 1 | | cs 0 | | io 0 | | io 1 | | io 2 | | io 3 | | s ck | | fb ck | | s ck | | io 0 | | io 1 | | io 2 | | io 3 | | da ta | | dir | | st p | | nx t | | data | | ck | | data | | da ta | | dir | | st p | | nx t | | data | | ck | | data | |
| SPI | | | | 1, 0 | | | | SPI 1 | | | | SPI 0 | | | | SPI 1 | | | | SPI 0 | | | | SPI 1 | | | | SPI 0 | | | | SPI 1 | | | | | | | | | | | | | | | | | | | | | |
| mo si | | mi so | | ck 0 | | ss 1 | | ss 2 | | ck | | mi so | | ss 0 | | ss 1 | | ss 2 | | mo si | | mi so | | ck 0 | | ss 1 | | ss 2 | | ck | | mi so | | ss 0 | | ss 1 | | ss 2 | | mo si | | mi so | | ck 0 | | ss 1 | | ss 2 | | | | | |
| SDIO | | | | 1, 0 | | | | SDIO 1 | | | | SDIO 0 | | | | SDIO 1 | | | | SDIO 0 | | | | SDIO 1 | | | | SDIO 0 | | | | SDIO 1 | | | | | | | | | | | | | | | | | | | | | |
| io 0 | | c m d | | ck 1 | | io 2 | | io 3 | | ck | | c m d | | ck 1 | | io 2 | | io 3 | | ck | | c m d | | ck 1 | | io 2 | | io 3 | | ck | | c m d | | ck 1 | | io 2 | | io 3 | | ck | | c m d | | ck 1 | | io 2 | | io 3 | | | | | |
| SD Card Detect and Write Protect are available in any of the shaded positions in any combination of the four signals. | | | | | | | | | | | | | | | | | | | | | | | | | | | | | | | | | | | | | | | | | | | | | | | | | | | | | |
| SD Card Power Controls are available on an odd/even pin basis that corresponds to SDIO controllers 0 and 1. | | | | | | | | | | | | | | | | | | | | | | | | | | | | | | | | | | | | | | | | | | | | | | | | | | | | | |
| SMC interface choice: NOR/SRAM or NAND Flash | | | | | | | | | | | | | | | | | | | | | | | | | | | | | | | | | | | | | | | | | | | | | | | | | | | | | |
| cs no te | | data | | oe bls | | data | | da ta | | address [0:24] | | | | | | | | | | | | | | | | | | NOR/SRAM | | MIO Pin 1 is optional: addr 25, cs 1 or gpio | | | | | | | | | | | | | | | | | | | | | | | |
| cs | | ale we | | io 0 | | io 1 | | cle rd | | io 4 ~ 7 | | io 3 bu sy | | io 8 ~ 15 | | | | | | | | | | NAND Flash | | | | | | | | | | | | | | | | | | | | | | | | | | | | | |
| | | | | | | | | | | 0 1 2 3 4 5 6 7 8 9 | | | | | | | | | | 0 1 2 3 4 5 6 7 8 9 0 1 2 3 4 5 6 7 8 9 0 1 2 3 4 5 6 7 8 9 0 1 2 3 | | | | | | | | | | 0 1 2 3 4 5 6 7 8 9 0 1 2 3 4 5 6 7 8 9 0 1 2 3 4 5 6 7 8 9 0 1 2 3 | | | | | | | | | | | | | | | | | | | | | | | |
| CAN | | 0 | | rx tx | | rx tx | | rx tx | | rx tx | | rx tx | | rx tx | | rx tx | | rx tx | | rx tx | | rx tx | | rx tx | | rx tx | | rx tx | | rx tx | | rx tx | | rx tx | | rx tx | | rx tx | | rx tx | | rx tx | | rx tx | | rx tx | | rx tx | | | | | |
| CAN | | 1 | | tx rx | | tx rx | | tx rx | | tx rx | | tx rx | | tx rx | | tx rx | | tx rx | | tx rx | | tx rx | | tx rx | | tx rx | | tx rx | | tx rx | | tx rx | | tx rx | | tx rx | | tx rx | | tx rx | | tx rx | | tx rx | | tx rx | | tx rx | | | | | |
| CAN External Clocks are optionally available on any pin in any combination | | | | | | | | | | | | | | | | | | | | | | | | | | | | | | | | | | | | | | | | | | | | | | | | | | | | | |
| UART | | 0 | | rx tx | | rx tx | | rx tx | | rx tx | | rx tx | | rx tx | | rx tx | | rx tx | | rx tx | | rx tx | | rx tx | | rx tx | | rx tx | | rx tx | | rx tx | | rx tx | | rx tx | | rx tx | | rx tx | | rx tx | | rx tx | | rx tx | | | | | | | |
| UART | | 1 | | tx rx | | tx rx | | tx rx | | tx rx | | tx rx | | tx rx | | tx rx | | tx rx | | tx rx | | tx rx | | tx rx | | tx rx | | tx rx | | tx rx | | tx rx | | tx rx | | tx rx | | tx rx | | tx rx | | tx rx | | tx rx | | tx rx | | | | | | | |
| I2C | | 0 | | ck d | | ck d | | ck d | | ck d | | ck d | | ck d | | ck d | | ck d | | ck d | | ck d | | ck d | | ck d | | ck d | | ck d | | ck d | | ck d | | ck d | | ck d | | ck d | | ck d | | ck d | | | | | | | | | |
| I2C | | 1 | | ck d | | ck d | | ck d | | ck d | | ck d | | ck d | | ck d | | ck d | | ck d | | ck d | | ck d | | ck d | | ck d | | ck d | | ck d | | ck d | | ck d | | ck d | | ck d | | ck d | | ck d | | | | | | | | | |
| System Timers | | TTC 0 | | Clk In, Wave Out | | w ck | | w ck | | w ck | | w ck | | w ck | | w ck | | w ck | | w ck | | w ck | | w ck | | w ck | | w ck | | w ck | | w ck | | w ck | | w ck | | w ck | | w ck | | w ck | | | | | | | | | | | |
| System Timers | | TTC 1 | | Clk In, Wave Out | | w ck | | w ck | | w ck | | w ck | | w ck | | w ck | | w ck | | w ck | | w ck | | w ck | | w ck | | w ck | | w ck | | w ck | | w ck | | w ck | | w ck | | w ck | | w ck | | | | | | | | | | | |
| System Timers | | SWDT | | Clk In, Reset Out | | ck r | | ck r | | ck r | | ck r | | ck r | | ck r | | ck r | | ck r | | ck r | | ck r | | ck r | | ck r | | ck r | | ck r | | ck r | | ck r | | ck r | | ck r | | | | | | | | | | | | | |
| GPIOs are available for each MIO pin. Pins 0 ~ 31 are controlled by GPIO bank 0. Pins 32 ~ 53 are controlled by GPIO bank 1. | | | | | | | | | | | | | | | | | | | | | | | | | | | | | | | | | | | | | | | | | | | | | | | | | | | | | |
| | | | | | | | | | | 0 1 2 3 4 5 6 7 8 9 | | | | | | | | | | 10 11 12 13 14 15 16 17 18 19 20 21 22 23 24 25 26 27 28 29 30 31 32 33 34 35 36 37 38 39 40 41 42 43 44 45 46 47 48 49 50 51 52 53 | | | | | | | | | | | | | | | | | | | | | | | | | | | | | | | | | |
| PJTAG Interface | | | | t di | | | | t do | | | | t ck | | | | t ms | | | | t di | | | | t do | | | | t ck | | | | t ms | | | | t di | | | | t do | | | | t ck | | | | t ms | | | | | |
| | | | | ck | | | | ctl | | | | ck | | | | ctl | | | | Clock and Control | | | | Trace Port User Interface | | | | | | | | | | | | | | | | | | | | | | | | | | | | | |
| | | | | 8 9 10 11 12 13 14 15 | | | | 2 3 | | | | 0 1 | | | | 4 5 6 7 | | | | 2 3 | | | | 0 1 | | | | Data | | | | Trace Port User Interface | | | | | | | | | | | | | | | | | | | | | |

2.5.5 MIO Signal Routing

Signal routing through the MIO is controlled by the MIO_PIN_[53:0] configuration registers located in the slcr registers set. The MIO multiplexes and de-multiplexes the various input and output signals to the MIO pins using four stages of multiplexing, as shown in Figure 2-4. The high-speed data signals (such as RGMII for Gigabit Ethernet and ULPI for USB) are routed through only one multiplexer stage. The slower signals (such as the UART and I2C ports) are routed through all four multiplexer stages. The routing for each MIO pin is independently controlled by multiple bit fields in each MIO_PIN register.

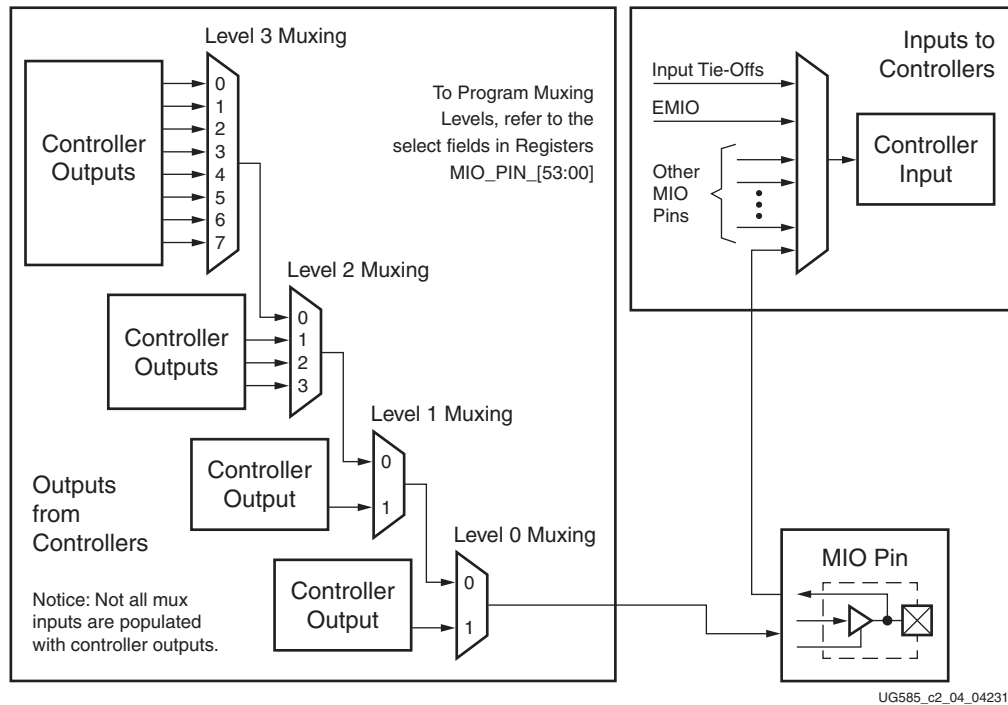

Figure 2-4: MIO Signal Routing

Any of the MIO pins can be programmed to be an external CAN controller reference clock using the CAN_MIOCLK_CTRL register.

2.5.6 Default Logic Levels

The inputs to the I/O peripherals are driven with default values when another source is not routed to either the MIO or the EMIO. If an input is routed to EMIO, but the PL is powered down, then the same default value is driven to the I/O peripheral. (See Figure 2-5.)

For MIO-only signals, the default signal input is driven when the MIO multiplexer does not route the signal to an MIO pin.

For MIO-EMIO signals, the default signal input is driven when the MIO multiplexer does not route the signal to an MIO pin (the signal defaults to the EMIO interface) and when the signal is programmed to be routed through the EMIO, but the PL either does not drive the signal (not configured) or is not able to drive it (powered down).

The default input signal logic levels are designed to be benign to the I/O peripheral. As a precaution, the related peripheral core should also be disabled when not in use. The logic levels are shown in the signal tables in each chapter for each I/O peripheral.

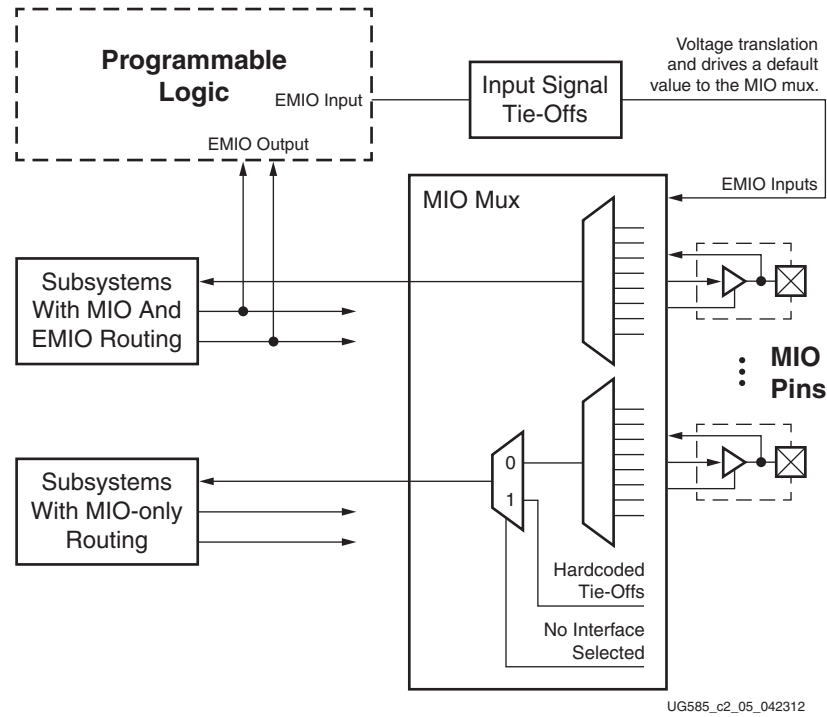

Figure 2-5: Non-selected Controller Inputs

2.5.7 MIO Pin Electrical Parameters

The MIO_PIN registers include bit fields to control the electrical pin characteristics of each I/O Buffer (GPIOB). This includes I/O buffer signaling voltage, slew rate, 3-state control, pull-up resistor, and HSTL enable. These are summarized in Table 2-5. Refer to the applicable Zynq-7000 SoC data sheet for electrical specifications.

Table 2-5: MIO I/O Buffer Programmable Parameters

| I/O Buffer Parameter | MIO_PIN Register Bit Field | Selections | Comments |
|------------------------------|----------------------------|----------------------------|---|
| Signaling | I/O_Type | LVC MOS (18, 25, 33), HSTL | Selects the drive and receiver type |
| HSTL Receiver ⁽¹⁾ | DisableRcvr | Enable, Disable | Enable when IO_Type = HSTL |
| Slew Rate | Speed | Fast, Slow | Selects edge rate for LVC MOS I/O types |
| 3-State Control | 3-State Control | Enable, Disable | Enables 3-state for all I/O types |
| Pull-up | Pull-up | Enable, Disable | Enables pull-up for all I/O types |

Notes:

- The HSTL receiver is useful for the GEM Ethernet PHY interface.



CAUTION! The allowable *V_{in High}* level voltage depends on the settings of the *slcr.MIO_PIN_xx[IO_Type]* and *[DisableRcvr]* bits. The restrictions are defined in the Zynq-7000 SoC data sheets. Damage to the input buffer can occur when the limits are exceeded.

VREF Source Considerations

The VREF pins for HSTL signaling can be from an internal or external source. The user should choose based system design needs. The reference source is selected using the slcr.GPIOB_CTRL [VREF_SW_EN] register bit.

2.6 PS–PL AXI Interfaces

The PS side of the AXI interfaces are based on the AXI 3 interface specification. Each interface consists of multiple AXI channels. The interfaces are summarized in [Table 2-6](#). Over a thousand signals are used to implement these nine PL AXI interfaces.

Note: The PL level shifters must be enabled via LVL_SHFTR_EN before PL logic communication can occur, refer to section [2.7.1 Clocks and Resets](#).

Table 2-6: PL AXI Interfaces

| Interface Name | Interface Description | Master | Slave | Signals |
|----------------|--|--------|-------|---|
| M_AXI_GP0 | General Purpose (AXI_GP) | PS | PL | Chapter 5, Interconnect has a section to describe each of these interfaces. The AXI signals are listed individually in section 5.6 PS-PL AXI Interface Signals . The AXI_ACP interface is also described in multiple places in Chapter 3, Application Processing Unit , including section 3.5.1 PL Co-processing Interfaces . The PS interconnect is shown in Figure 5-1 . |
| M_AXI_GP1 | | PS | PL | |
| S_AXI_GP0 | General Purpose (AXI_GP) | PL | PS | |
| S_AXI_GP1 | | PL | PS | |
| S_AXI_ACP | Accelerator Coherency Port, cache-coherent transaction (ACP) | PL | PS | |
| S_AXI_HP0 | High Performance ports (AXI_HP) with read/write FIFOs and two dedicated memory ports on DDR controller and a path to the OCM. The AXI_HP interfaces are known also as AFI. | PL | PS | |
| S_AXI_HP1 | | PL | PS | |
| S_AXI_HP2 | | PL | PS | |
| S_AXI_HP3 | | PL | PS | |

2.7 PS–PL Miscellaneous Signals

The programmable logic interface group contains miscellaneous interfaces between PS and the PL. An input is driven by the PL and an output is driven by the PS. Signals might have suffixes where an 'N' suffix indicates an active Low signal; otherwise the signal is active High. A 'TN' suffix indicates an active Low 3-state enable signal and is an output to the PL. Output signals to the PL are always driven to either a High or Low level state.

PS-PL signal groups are identified in [Table 2-7](#).

Table 2-7: PS-PL Signal Groups

| PS-PL Signal Group | Signal Name | Reference |
|--|-----------------|--|
| PL clocks and resets | FCLKx | 2.7.1 Clocks and Resets |
| PL interrupts to PS | IRQF2Px | 2.7.2 Interrupt Signals |
| IOP interrupts to PL | IRQP2Fx | 2.7.2 Interrupt Signals |
| Events | EVENTx | 2.7.3 Event Signals |
| IdleAXI, DDR ARB, SRAM interrupt, FPGA | FPGA, DDR, EMIO | 2.7.4 Idle AXI, DDR Urgent/Arb, SRAM Interrupt Signals |
| DMA controller | DMACx | 2.7.5 DMA Req/Ack Signals |
| EMIO signals | EMIOx | Table 2-3 |
| USB port indicator and power control | EMIOUSBx | 15.16.3 MIO-EMIO Signals |

Note: The PL level shifters must be enabled via the `sclr.LVL_SHFTR_EN` register before PL logic communication can occur, refer to section [2.7.1 Clocks and Resets](#).

2.7.1 Clocks and Resets

Clocks

The PS clock module provides four frequency-programmable clocks (FCLKs) to the PL that are physically spread out along the PS-PL boundary. The clocks can also be individually controlled. The FCLK clocks can be routed to PL clock buffers to serve as a frequency source.

Note: There is no guaranteed timing relationship between any of the four PL clocks and between any of the other PS-PL signals. Each clock is independently programmed and operated. The FCLKCLKTRIGN[3:0] signals are currently not supported. They must be tied to ground in the PL. The FCLK clocks are described in [Chapter 25, Clocks](#).

Resets

The PS reset subsystem provides four programmable reset signals to the PL. The reset signals are controlled by writing to the `sclr.FPGA_RST_CTRL` `SLCR[FPGA[3:0]_OUT_RST]` bit fields. The resets are independently programmed and are completely independent of the PL clocks and all other PS-PL signals. The PS reset subsystem is described in [Chapter 26, Reset System](#).

The PL clocks and resets are summarized in [Table 2-8](#).

Table 2-8: PL Clock and Reset Signals

| Type | PL Signal Name | I/O | Reference |
|---------------------------|-------------------|-----|--|
| PL Clocks | FCLKCLK[3:0] | O | Chapter 25, Clocks |
| PL Clock Throttle Control | FCLKCLKTRIG [3:0] | I | |
| PL Resets | FCLKRESETN [3:0] | O | Chapter 26, Reset System |

2.7.2 Interrupt Signals

The interrupts from the processing system I/O peripherals (IOP) are routed to the PL and assert asynchronously to the FCLK clocks. In the other direction, the PL can asynchronously assert up to 20 interrupts to the PS. Sixteen of these interrupt signals are mapped to the interrupt controller as a peripheral interrupt where each interrupt signal is set to a priority level and mapped to one or both of the CPUs. The remaining four PL interrupt signals are inverted and routed to the nFIQ and nIRQ interrupt directly to the signals to the private peripheral interrupt (PPI) unit of the interrupt controller. There is an nFIQ and nIRQ interrupt for each of two CPUs. The PS to PL and PL to PS interrupts are listed in [Table 2-9](#). Details of the interrupt signals are described in [Chapter 7, Interrupts](#).

Table 2-9: PL Interrupt Signals

| Type | PL Signal Name | I/O | Destination |
|---------------------|----------------|-----|--|
| PL to PS Interrupts | IRQF2P[7:0] | I | SPI: Numbers [68:61]. |
| | IRQF2P[15:8] | I | SPI: Numbers [91:84]. |
| | IRQF2P[19:16] | I | PPI: nFIQ, nIRQ (both CPUs). |
| PS to PL Interrupts | IRQP2F[27:0] | O | PI Logic. These signals are received from the I/O peripherals and are forwarded to the interrupt controller. These signals are also provided as outputs to the PL. |

2.7.3 Event Signals

The PS supports processor events to and from the PL (see [Table 2-10](#)). These signals are asynchronous to the PS and FCLK clocks. For details on these signals, see [Chapter 3, Application Processing Unit](#).

Table 2-10: PL Event Signals

| Type | PL Signal Name | I/O | Description |
|---------|----------------------|-----|--|
| Events | EVENTEVENTI | I | Causes one or both CPUs to wake up from a WFE state. |
| | EVENTEVENTO | O | Asserted when one of the CPUs has executed the SEV instruction. |
| Standby | EVENTSTANDBYWFE[1:0] | O | CPU standby mode: asserted when a CPU is waiting for an event. |
| | EVENTSTANDBYWFI[1:0] | O | CPU standby mode: asserted when a CPU is waiting for an interrupt. |

2.7.4 Idle AXI, DDR Urgent/Arb, SRAM Interrupt Signals

The idle AXI signal to the PS is used to indicate that there are no outstanding AXI transactions in the PL. It cannot be read from any registers. Driven by the PL, this signal is one of the conditions used to initiate a PS bus clock shut-down by ensuring that all PL bus devices are idle.

The DDR urgent/arb signal is used to signal a critical memory starvation situation to the DDR arbitration for the four AXI ports of the PS DDR memory controller. The EMIOSRAMINT signal is used to alert the PL that the static memory controller has triggered an interrupt.

Table 2-11: PL AXI Idle, DDR Urgent/Arb and SRAM Interrupt Signals

| Type | PL Signal Name | I/O | Destination | Reference |
|------------------------|----------------|-----|--|---|
| Idle PL AXI Interfaces | FPGAIDLEN | I | Central interconnect clock disable logic | Central Interconnect Clock Disable in section 25.1.4 Power Management |
| DDR Urgent Signal | DDRARB[3:0] | I | DDR memory controller | Chapter 10, DDR Memory Controller |
| SRAM | EMIOSRAMINTIN | I | Static memory controller interrupt | Chapter 11, Static Memory Controller |

2.7.5 DMA Req/Ack Signals

There are four sets of DMA controller flow control signals for use by up to four PL slaves connected via the M_AXI_GP interfaces (see [Table 2-11](#)). These four sets of flow control signals correspond to DMA channels 4 through 7, see [Chapter 9, DMA Controller](#).

Table 2-12: PL DMA Signals

| Type | Signal | PL Signal Name | I/O | Reference |
|-----------------|--------|---------------------|-----|---|
| Clock and Reset | Clock | DMA[3:0]ACLK | I | 9.2.7 PL Peripheral Request Interface |
| Request | Ready | DMA[3:0]DRREADY | O | Chapter 9, DMA Controller |
| | Valid | DMA[3:0]DRVALID | I | |
| | Type | DMA[3:0]DRTYPE[1:0] | I | |
| | Last | DMA[3:0]DRLAST | I | |
| Acknowledge | Ready | DMA[3:0]DAREADY | I | |
| | Valid | DMA[3:0]DAVALID | O | |
| | Type | DMA[3:0]DATYPE[1:0] | O | |

2.8 PL I/O Pins

A summary of the PL I/O pins is shown in [Table 2-13](#). Refer to the applicable Zynq-7000 SoC data sheet and Zynq-7000 SoC packaging and pin documents for more information.

For more information on multi-gigabit serial transceivers pins, see the Pin Description and Design Guidelines section in [UG476, 7 Series FPGAs GTX Transceivers User Guide](#). (Four to sixteen transceivers are available in the Kintex-based Zynq 7z030, 7z035, 7z045, and 7z100 devices.)

7z007s and 7z010 Device Notice

Devices in CLG225 packages (7z010 dual core and 7z007s single core devices) have fewer pins than the other Zynq-7000 SoC devices. For these devices, DXN is tied to ground, Bank 34 has 46 I/Os, and Bank 35 has 8 I/Os. There are also only four pairs of XADC signals.



CAUTION! The allowable *V_{in}* High level voltages are defined in the Zynq-7000 SoC data sheets. Damage to the input buffer can occur when the limits are exceeded.

Table 2-13: PL Pin Summary

| Group | Name | Type | Description |
|-----------------------------------|--------------------------------|----------------|--|
| User I/O Pins | IO_LXXY_#, IO_XX_# | I/O | Most user I/O pins are capable of differential signaling and can be implemented as pairs. The top and bottom I/O pins are always single ended. |
| Multi-Gigabit Serial Transceivers | MGTXRXP[N] | I | Differential receive and transmit ports. Multi-Gigabit Serial Transceiver pins. Four transceivers are available in the Zynq-7000 SoC 7z030 device and 16 in the 7z035, 7z045 and 7z100 devices. |
| | MGTXTXP[N] | O | |
| | MGTAVCC_G# | I | 1.0V analog power-supply pin for receiver and transmitter internal circuits. |
| | MGTAVTT_G# | I | 1.2V analog power-supply pin for the transmit driver. |
| | MGTVCCAUX_G# | I | 1.8V auxiliary analog Quad PLL voltage supply for the transceivers. |
| | MGTREFCLK0/1P | I | Positive differential reference clock for the transceivers. |
| | MGTREFCLK0/1N | I | Negative differential reference clock for the transceivers. |
| | MGTAVTTRCAL | N/A | Precision reference resistor pin for internal calibration termination. |
| | MGTRREF | I | Precision reference resistor pin for internal calibration termination. |
| PL JTAG | PL_TCK, PL_TMS, PL_TDI, PL_TDO | I/O | See Chapter 27, JTAG and DAP Subsystem . |
| Configuration | DONE, INIT_B, PROGRAM_B | I/O | Refer to the 7-series documentation. |
| | CFGBVS | I | Pre-configuration I/O standard type for the dedicated configuration bank 0. |
| | PUDC_B | I | Active Low input enables internal pull-ups during configuration on all SelectIO pins. |
| XADC | VP, VN | I | Dedicated differential analog inputs. |
| | VREFP, VREFN | N/A | Reference input (1.25V) and ground. |
| | AD[15:0]P, AD[15:0]N | I | 16 differential auxiliary analog inputs. |
| Multi-function | MRCC | I | Clock capable I/Os driving BUFRRs, BUFIOs, BUFGs and MMCMs/PLLs. In addition, these pins can drive the BUFMR for multi-region BUFIO and BUFRR support. These pins become regular user I/Os when not needed as a clock. |
| | SRCC | I | Clock capable I/Os driving BUFRRs, BUFIOs and MMCMs/PLLs. These pins become regular user I/Os when not needed for clocks. |
| | T[3:0] | Multi-Function | Four memory byte groups. |
| | T[3:0]_DQS | Multi-Function | DDR DQS strobe pin that belongs to the memory byte group T0-T3. |
| Temperature | DXP, DXN | Dedicated | Temperature-sensing diode pins. |
| Reserved | RSVDVCC | Dedicated | Tie to V _{CCO_0} . |
| | RSVDGND | Dedicated | Do not connect. |

Application Processing Unit

3.1 Introduction

3.1.1 Basic Functionality

The application processing unit (APU), located within the PS, contains one processor for single-core devices or two processors for dual-core devices. These are Arm® Cortex™-A9 processors with NEON co-processors connected in an MP configuration sharing a 512 KB L2 cache. Each processor is a high-performance and low-power core that implements two separate 32 KB L1 caches for instruction and data. The Cortex-A9 processor implements the Arm v7-A architecture with full virtual memory support and can execute 32-bit Arm instructions, 16-bit and 32-bit Thumb instructions, and 8-bit Java™ byte codes in the Jazelle state. The NEON™ co-processor media and signal processing architecture adds instructions that target audio, video, image and speech processing, and 3D graphics. These advanced single instruction multiple data (SIMD) instructions are available in both Arm and Thumb states. A block diagram of the APU is shown in [Figure 3-1](#).

The Cortex-A9 processor(s) within the APU are organized in an MP configuration with a snoop control unit (SCU) responsible for maintaining L1 cache coherency between the two processors and the ACP interface from the PL. To increase performance, there is a shared unified 512 KB level-two (L2) cache for instruction and data. In parallel to the L2 cache, there is a 256 KB on-chip memory (OCM) module that provides a low-latency memory.

An accelerator coherency port (ACP) facilitates communication between the programmable logic (PL) and the APU. This 64-bit AXI interface allows the PL to implement an AXI master that can access the L2 and OCM while maintaining memory coherency with the CPU L1 caches.

The unified 512 KB L2 cache is 8-way set-associative and allows you to lock the cache content on a line, way, or master basis. All accesses through the L2 cache controller can be routed to the DDR controller or can be sent to other slaves in the PS or PL depending on their address. To reduce latency to the DDR memory, there is a dedicated port from the L2 controller to the DDR controller.

Debug and trace capability is built into the two processor cores and interconnects as a part of the CoreSight™ debug and trace system. You can control and interrogate the processor(s) and the memory through the debug access port (DAP). Furthermore, 32-bit AMBA® trace bus (ATB) masters from the processor(s) are funneled with other ATB masters, such as Instrumentation Trace Macrocell (ITM) and Fabric Trace Monitor (FTM), to generate the unified PS trace through the on-chip embedded trace buffer (ETB) or the trace-port interface units (TPIU).

3.1.2 System-Level View

The APU is the most critical component of the system that comprises the PS, the IP cores implemented in the PL, and board-level devices such as the external memories and the peripherals. The main interfaces through which the APU communicates to the rest of the system are two interfaces through the L2 controller and an interface to the OCM that is parallel to the L2 cache. See [Figure 3-1](#).

All accesses from the dual/single Cortex-A9 MP system go through the SCU and all accesses from any other master that requires coherency with the Cortex-A9 MP system also need to be routed through the SCU using the ACP Port. All accesses that are not routed through the SCU are non-coherent with the CPU and software has to explicitly handle the synchronization and coherency.

Accesses from the APU can target the OCM, DDR, PL, IOP slaves, or registers within the PS sub-blocks. To minimize the latency to the OCM, a dedicated master port from the SCU provides direct access by the processors and the ACP to the OCM, offering a latency that is even less than the L2 cache.

All APU accesses to the DDR are routed through the L2 cache controller. To improve the latencies of the DDR accesses, there is a dedicated master port from the L2 cache controller to the DDR memory controller that allows all APU-DDR transactions to bypass the main interconnects which are shared with the other masters. All other accesses from the APU that are neither OCM-bound nor DDR-bound go through the L2 controller and are routed through the main interconnect using a second port. The accesses that pass through the L2 cache controller do not have to be cacheable.

Exclusive access transactions from LDREX/SDREX instructions or ACP exclusive transactions in the APU are described under [Exclusive AXI Accesses in Chapter 5](#). As shown in [Figure 3-2](#), the APU and its sub-blocks all operate in the CPU_6x4x clock domain. The interfaces from the APU to the OCM and to the main interconnects are all synchronous. The main interconnects can run at 1/2 or 1/3 of the frequency of the CPU. The DDR block is on the DDR_3x clock domain and operates asynchronously to the APU. The ACP port to the APU block includes a synchronizer and the PL master that uses this port can have a clock that is asynchronous to the APU.

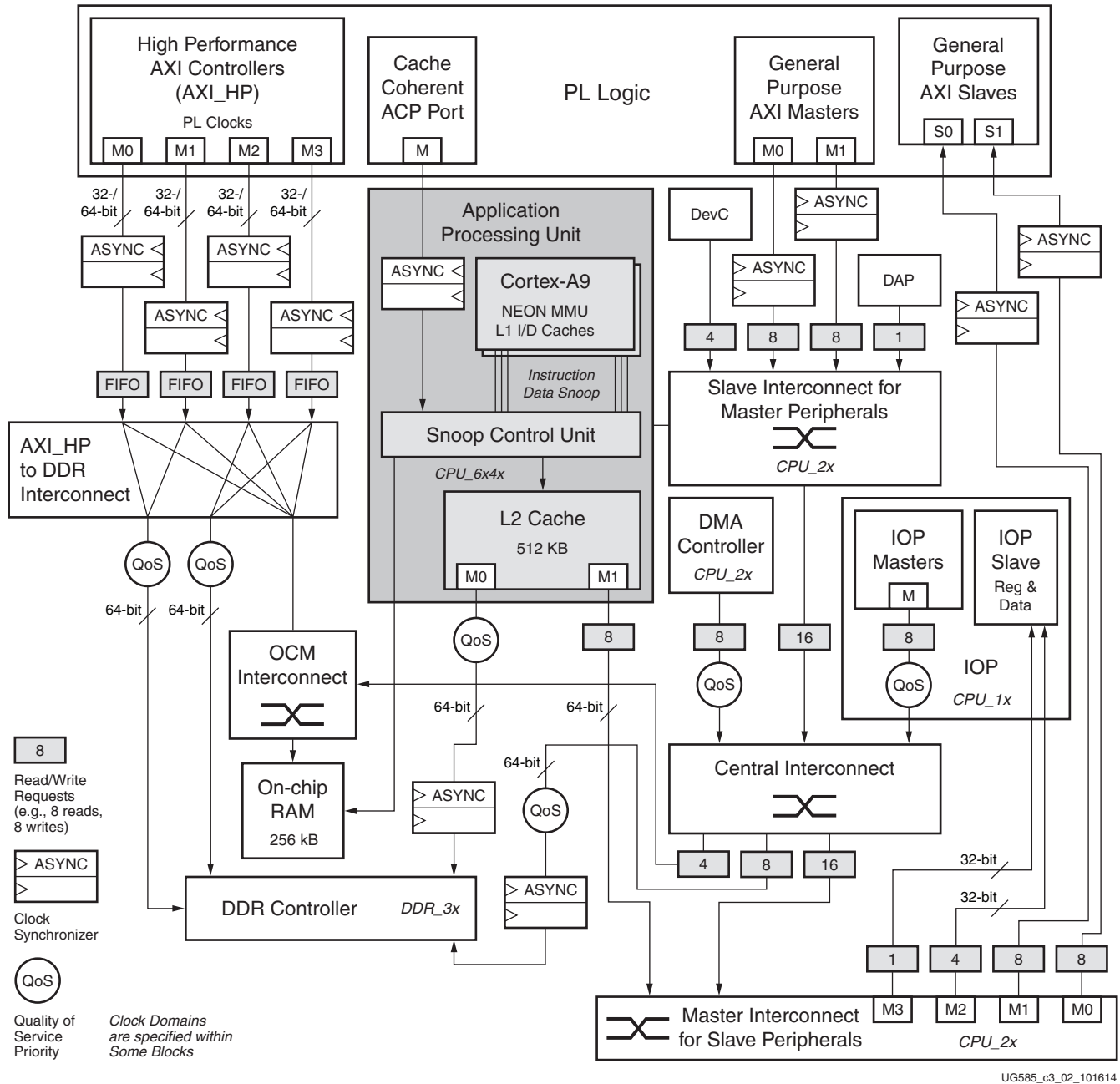

Figure 3-2: APU System View Diagram

3.2 Cortex-A9 Processors

3.2.1 Summary

The APU implements a dual/single-core Cortex-A9 MP configuration. Each processor has its own SIMD media processing engine (NEON), memory management unit (MMU), and separate 32 KB level-one (L1) instruction and data caches. Each Cortex-A9 processor provides two 64-bit AXI master interfaces for independent instruction and data transactions to the SCU. Depending on the address and attributes, these transactions are routed to the OCM, L2 cache, DDR memory, or, through the PS interconnect, to other slaves in the PS, or to the PL. Each processor interface with the SCU includes the required snoop signals to provide coherency between the L1 data caches within the processors and the shared L2 cache for shareable memory. The Cortex-A9 and its subsystem also provide complete Trustzone extension, necessary for user security.

The Cortex-A9 processor implements the necessary hardware features for program debug and trace generation support. The processor also provides hardware counters to gather statistics on the operation of the processor and memory system.

The major sub-blocks within the Cortex-A9 are the central processing unit (CPU), the L1 instruction and data caches, the memory management unit (MMU), the NEON coprocessor, and the core interfaces. Their functions are explained in the following subsections.

3.2.2 Central Processing Unit (CPU)

Each Cortex-A9 CPU can issue two instructions in one cycle and execute them out of order. The CPU implements dynamic branch prediction and with its variable length pipeline can deliver 2.5 DMIPs/MHz. The Cortex-A9 processor implements the Armv7-A architecture with full virtual memory support and can execute 32-bit Arm instructions, 16-bit and 32-bit Thumb instructions, and 8-bit Java™ byte codes in the Jazelle hardware acceleration state. [Figure 3-3](#) shows the architecture of the Cortex-A9 processor.

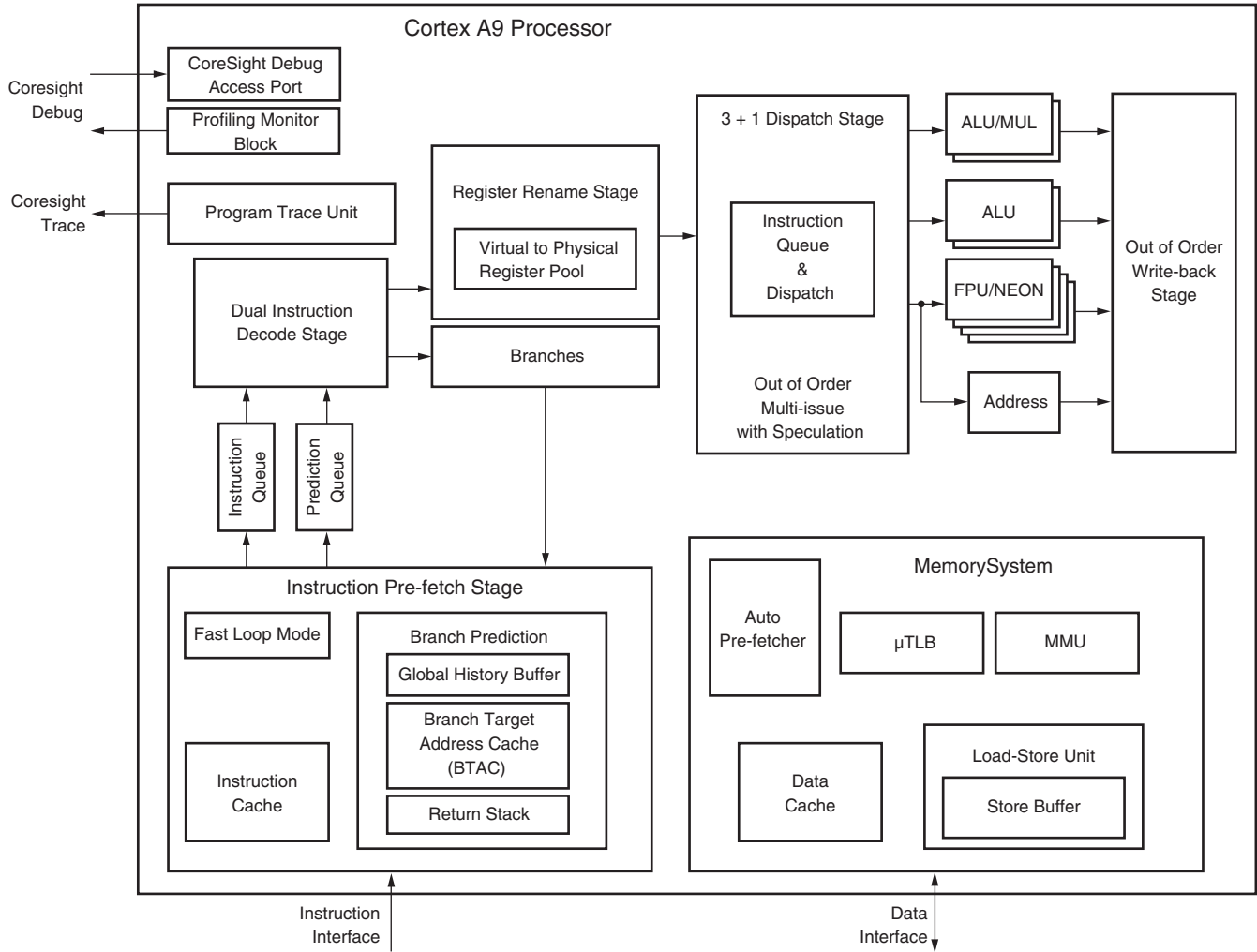

UG585_c3_04_030712

Figure 3-3: Cortex-A9 Architecture

Pipeline

The pipeline implemented in the Cortex-A9 CPU employs advanced fetching of instructions and branch prediction that decouples the branch resolution from potential memory latency-induced instruction stalls. In the Cortex-A9 CPU, up to four instruction-cache lines are pre-fetched to reduce the impact of memory latency on the instruction throughput. The CPU fetch unit can continuously forward two to four instructions per cycle to the instruction decode buffer to ensure efficient superscalar pipeline utilization. The CPU implements a superscalar decoder capable of decoding two full instructions per cycle, and any of the four CPU pipelines can select instructions from the issue queue. The parallel pipelines support concurrent execution across full dual arithmetic units, load-store unit, plus resolution of any branch each cycle.

The Cortex-A9 CPU employs speculative execution of instructions enabled by dynamic renaming of physical registers into an available pool of virtual registers. The CPU employs this virtual register renaming to eliminate dependencies across registers without jeopardizing the correct execution of programs. This feature allows code acceleration through an effective hardware based unrolling of

loops, and increases the pipeline utilization by removing data dependencies between adjacent instructions, which also indirectly reduces interrupt latency.

In the Cortex-A9 CPU, dependent load-store instructions can be forwarded for resolution within the memory system to further reduce pipeline stalls. The core supports up to four data cache line fill requests that can be through automatic or user-driven pre-fetching.

A key feature of this CPU is the out-of-order write back of instructions that enables the pipeline resources to be released independent of the order in which the system provides the required data.

Load/store instructions can be issued speculatively before condition of instruction or a preceding branch has been resolved or before data to be written has become available. If the condition required for the execution of the load/store fails, any of the side-effects, such as the action to modify registers, are flushed.

Branch Prediction

To minimize the branch penalty in its highly pipelined CPU, the Cortex-A9 implements both static and dynamic branch prediction. Static branch prediction is provided by the instructions and is decided during compilation. Dynamic branch prediction uses the outcome of the previous executions of a specific branch to determine whether the branch should be taken or not. The dynamic branch prediction logic employs a global branch history buffer (GHB) which is a 4,096 entry table holding 2-bit prediction information for specific branches and is updated every time a branch gets executed.

The branch execution and the overall instruction throughput also benefit greatly from the implementation of a branch target address cache (BTAC) which holds the target addresses of the recent branches. This 512-entry address cache is organized as 2-way \times 256 entries and provides the target address for a specific branch to the pre-fetch unit before the actual target address is generated based on the calculation of the effective address and its translation to the physical address. Additionally, if an instruction loop fits in four BTAC entries, instruction cache accesses are turned off to lower power consumption.

Note: Both GHB and BTAC RAMs implement parity for protection; however, this support has limited diagnostic value. Corruption in GHB data or BTAC data does not generate functional errors in the Cortex-A 9 processor. Corruption in GHB data or BTAC data results in faulty branch prediction that is detected and corrected when the branch gets executed.

The Cortex-A9 CPU can predict conditional branches, unconditional branches, indirect branches, PC-destination data-processing operations, and branches that switch between Arm and Thumb states. However, the following branch instructions are not predicted:

- Branches that switch between states (except Arm to Thumb transitions, and Thumb to Arm transitions)
- Instructions with the S suffix are not predicted, as they are typically used to return from exceptions and have side effects that can change privilege mode and security state.
- All mode-changing instructions

Users can enable program flow prediction by setting the Z bit in the CP15 c1 Control register to 1. Refer to the System Control Register in the *Arm Cortex-A9 Technical Reference Manual* (see [Appendix A, Additional Resources](#)). Before switching the program flow prediction on, a BTAC flush operation must be performed which has the additional effect of setting the GHB into a known state.

Cortex-A9 also employs an 8-entry return stack cache that holds the 32-bit subroutine return addresses. This feature greatly reduces the penalty of executing subroutine calls and can address nested routines up to eight levels deep.

Instruction and Data Alignment

Arm architecture specifies the Arm instructions as being 32-bits wide and requires them to be word-aligned. Thumb instructions are 16-bits wide and are required to be half-word aligned. Thumb-2 instructions which are 16- or 32-bits wide are also required to be half-word aligned. Data accesses can be unaligned and the load/store unit within the CPU breaks them up to aligned accesses. The data from these accesses are merged and sent to the register file within the CPU as had been requested.

Note: The application processing unit (APU), and the PS as a whole, support only little-endian architecture for both instruction and data.

Trace and Debug

The Cortex-A9 processor implements the Armv7 debug architecture as described in the *Arm Architecture Reference Manual (Armv7-A)*. In addition, the processor supports a set of Cortex-A9 processor-specific events and system-coherency events. For more information, see *Chapter 11, Performance Monitoring Unit* in the Arm Cortex-A9 Technical Reference Manual.

The debug interface of the processor consists of:

- A baseline CP14 interface that implements the Armv7 debug architecture and the set of debug events as described in the *Arm Architecture Reference Manual (Armv7-A)*
- An extended CP14 interface that implements a set of debug events specific to this processor as explained in the *Arm Architecture Reference Manual (Armv7-A)*
- An external debug interface connected to an external debugger through a debug access port (DAP)

The Cortex-A9 includes a program trace module that provides Arm CoreSight technology compatible program-flow trace capabilities for either of the Cortex-A9 processors and provides full visibility into the actual instruction flow of the processor. The Cortex-A9 PTM includes visibility over all code branches and program flow changes with cycle-counting enabling profiling analysis. The PTM block in conjunction with the CoreSight design kit provides the software developer the ability to non-obtrusively trace the execution history of multiple processors and either store this, along with time stamped correlation, into an on-chip buffer, or off chip through a standard trace interface so as to have improved visibility during development and debug.

The Cortex-A9 processor also implements program counters and event monitors that can be configured to gather statistics on the operation of the processor and the memory system.

3.2.3 Level 1 Caches

Each of the two Cortex-A9 processors has separate 32 KB level-1 instruction and data caches. Both L1 caches have common features that include:

- Each cache can be disabled independently, using the system control coprocessor. Refer to the System Control Register in the *Arm Cortex-A9 Technical Reference Manual*.
- The cache line lengths for both L1 caches are 32 bytes.
- Both caches are 4-way set-associative.
- L1 caches support 4 KB, 64 KB, 1 MB, and 16 MB virtual memory page.
- Neither of the two L1 caches supports the lock-down feature.
- The L1 caches have 64-bit interfaces to the integer core and AXI master ports.
- Cache replacement policy is either pseudo round-robin or pseudo-random. The victim counter is read at time of miss, not allocation, and it is incremented on allocation. An invalid line in the set is replaced in preference to using the victim counter.
- On a cache miss, critical word first filling of the cache is performed.
- To reduce power consumption, the number of full cache reads is reduced by taking advantage of the sequential nature of many cache operations. If a cache read is sequential to the previous cache read, and the read is within the same cache line, only the data RAM set that was previously read is accessed.
- Both L1 caches support parity.
- All memory attributes are exported to external memory systems.
- Support for TrustZone security exports the secure or non-secure status to the caches and memory system.
- Upon a CPU reset, the contents of both L1 caches are cleared to comply with security requirements.

Note: You must invalidate the instruction cache, the data cache, and BTAC before using them. It is not required to invalidate the main TLB, even though it is recommended for safety reasons. This ensures compatibility with future revisions of the processor.

The L1 instruction-side cache (I-Cache) is responsible for providing an instruction stream to the Cortex-A9 processor. The L1 I-Cache interfaces directly to the pre-fetch unit which contains a two-level prediction mechanism as described in the [Branch Prediction](#) section of this chapter. The L1 instruction cache is virtually indexed and physically tagged.

The L1 data-side cache (D-Cache) is responsible for holding the data used by the Cortex-A9 processor. Key features of the L1 D-Cache include:

- Data cache is physically indexed and physically tagged.
- D-Cache is non-blocking and, therefore, load/store instructions can continue to hit the cache while it is performing allocations from external memory due to prior read/write misses. The data cache supports four outstanding reads and four outstanding writes.
- The CPU can support up to four outstanding preload (PLD) instructions. However, explicit load/store instructions have higher priority.
- The Cortex-A9 load/store unit supports speculative data pre-fetching which monitors sequential accesses made by program and starts fetching the next expected line before it has been requested. This feature is enabled in the cp15 Auxiliary Control register (DP bit). The pre-fetched lines can be dropped before allocation, and PLD instruction has higher priority.
- The data cache supports two 32-byte line-fill buffers and one 32-byte eviction buffer.
- The Cortex-A9 CPU has a store buffer with four 64-bit slots with data merging capability.

- Both data cache read misses and write misses are non-blocking, with up to four outstanding data cache read misses and up to four outstanding data cache write misses being supported.
- The APU data caches offer full snoop coherency control using the MESI algorithm.
- The data cache in Cortex-A9 contains local load/store exclusive monitor for LDREX/STREX synchronizations. These instructions are used to implement semaphores. The exclusive monitor handles one address only, with eight words or one cache line granularity. Therefore, avoid interleaving LDREX/STREX sequences and always execute a CLREX instruction as part of any context switch.
- D-Cache only supports write-back/write-allocate policy. Write-through and write-back/no write-allocate policies are not implemented.
- L1 D-Cache offers support for exclusive operation with respect to the L2 cache. Exclusive operation implies that a cache line is valid only in L1 or L2 cache and never in both at the same time. A line-fill into L1 causes the line to be marked invalid in L2. At the same time, eviction of a line from L1 causes the line to be allocated in L2, even if it is not dirty. A line-fill into L1 from dirty L2 line forces eviction of the line to external memory. The exclusive operation, disabled by default, increases cache utilization and reduces power consumption.

Initialization of L1 Caches

Before using the L1 caches, you must invalidate the instruction cache, the data cache, and the BTAC. It is not required to invalidate the main TLB, even though it is recommended for safety reasons. This ensures compatibility with future revisions of the processor. Steps to initialize L1 Caches:

1. Invalidate TLBs:

```
mcr    p15, 0, r0, c8, c7, 0 (r0 = 0)
```

2. Invalidate I-Cache:

```
mcr    p15, 0, r0, c7, c5, 0 (r0 = 0)
```

3. Invalidate Branch Predictor Array:

```
mcr    p15, 0, r0, c7, c5, 6 (r0 = 0)
```

4. Invalidate D-Cache:

```
mcr    p15, 0, r11, c7, c14, 2 (should be done for all the sets/ways)
```

5. Initialize MMU.

6. Enable I-Cache and D-Cache:

```
mcr    p15, 0, r0, c1, c0, 0 (r0 = 0x1004)
```

7. Synchronization barriers:

```
dsb    (Allows MMU to start)
```

```
isb    (Flushes pre-fetch buffer)
```

(Refer to [Memory Barriers](#), page 73 for more details on memory barriers.)

3.2.4 Memory Ordering

Memory Ordering Model

The Cortex-A9 architecture defines a set of memory attributes with the characteristics required to support all memory and devices in the system memory map. The following mutually-exclusive main memory type attributes describe the memory regions:

- Normal
- Device
- Strongly-ordered

Device and Strongly Ordered

Accesses to strongly ordered and device memory have the same memory ordering model. System peripherals come under strongly ordered and device memory. Access rules for this memory are as follows:

- The number and size of accesses are preserved. Accesses are atomic, and will not be interrupted part way through.
- Both read and write accesses can have side effects on the system. Accesses are never cached. Speculative accesses are never performed.
- Accesses cannot be unaligned.
- The order of accesses arriving at device memory is guaranteed to correspond to the program order of instructions which access strongly ordered or device memory. This guarantee applies only to accesses within the same peripheral or block of memory.
- The Cortex-A9 processor can re-order normal memory accesses around strongly ordered or device memory accesses.

The only difference between device and strongly ordered memory is that:

- A write to strongly ordered memory can complete only when it reaches the peripheral or memory component accessed by the write.
- A write to device memory is permitted to complete before it reaches the peripheral or memory component accessed by the write.

Normal Memory

Normal memory is used to describe most parts of the memory system. All ROM and RAM devices are considered to be normal memory. All code to be executed by the processor must be in normal memory. Code is not architecturally permitted to be in a region of memory which is marked as device or strongly ordered. The properties of normal memory are as follows:

- The processor can repeat read and some write accesses.
- The processor can pre-fetch or speculatively access additional memory locations, with no side-effects (if permitted by MMU access permission settings). The processor does perform speculative writes.

- Unaligned accesses can be performed.
- Multiple accesses can be merged by processor hardware into a smaller number of accesses of a larger size. Multiple byte writes could be merged into a single double-word write, for example.

Memory Attributes

In addition to memory types, the ordering of accesses for regions of memory is also defined by the memory attributes. The following sub-sections discuss these attributes.

Shareability

Shareability domains define *zones* within the bus topology within which memory accesses are to be kept consistent (taking place in a predictable way) and potentially coherent (with hardware support). Outside of this domain, masters might not see the same order of memory accesses as inside it. The order of memory accesses takes place in these defined domains. [Table 3-1](#) shows the different shareability options available in a Cortex-A9 system:

Table 3-1: Shareability Domains

| Domain | Abbreviation | Description |
|-----------------|--------------|---|
| Non-Shareable | NSH | A domain consisting only of the local master. Accesses that never need to be synchronized with other cores, processors or devices. Not normally used in SMP systems. |
| Inner shareable | ISH | A domain (potentially) shared by multiple masters, but usually not all masters in the system. A system can have multiple inner shareable domains. An operation that affects one inner shareable domain does not affect other inner shareable domains in the system. |
| Outer shareable | OSH | A domain almost certainly shared by multiple masters, and quite likely consisting of several inner shareable domains. An operation that affects an outer shareable domain also implicitly affects all inner shareable domains within it. |
| Full system | SY | An operation on the full system affects all masters in the system; all non-shareable regions, all inner shareable regions and all outer shareable regions. |

Shareability only applies to normal memory, and to device memory in an implementation that does not include the large physical address extensions (LPAE). In an implementation that includes the LPAE, device memory is always outer shareable. For more information on LPAE, refer to the *Arm Technical Reference Manual*.

Cacheability

Cacheable attributes apply only for the normal memory type. These attributes provide a mechanism of coherency control with masters that lie outside the shareability domain of a region of memory. Each region of normal memory is assigned a cacheable attribute that is one of:

- Write-back cacheable
- Write-through cacheable
- Non-cacheable

See the Cache Policies of Arm architecture, for information on these attributes.

The Cortex-A9 CPU also provides independent cacheability attributes for normal memory for two conceptual levels of cache, the inner and the outer cacheable. Inner refers to the innermost caches, and always includes the lowest level of cache, that is, L1 cache. Outer cache refers to L2 cache. No cache controlled by the inner cacheability attributes can lie outside a cache controlled by the outer cacheability attributes.

Memory Barriers

A memory barrier is an instruction or sequence of instructions that forces synchronization events by a processor with respect to retiring load/store instructions. Cortex-A9 CPU requires three explicit memory barriers to support the memory order model. They are:

- Data memory barrier
- Data synchronization barrier
- Instruction synchronization barrier

These barriers provide the functionality to order and complete load/store instructions. This also helps in context synchronization.

Data Memory Barrier (DMB)

In a program, the use of the DMB instruction ensures that all of the instructions that access memory should be completed/observed in the system before any memory access instructions that come up after the DMB instruction. It does not affect the ordering of any other instructions executing on the processor, or of instruction fetches.

Example: Weakly Ordered Message Passing Problem

Consider the following instructions executing on processor P1 and P2:

```
P1:
  STR R5, [R1]      ; set new data
  STR R0, [R2]      ; send flag indicating data ready
P2:
  WAIT ([R2]==1)    ; wait on flag
  LDR R5, [R1]      ; read new data
```

Here, the order of memory accesses seen by the other processor might not be the order that appears in the program, for either loads or stores. The addition of barriers ensures that the observed order of both the reads and the writes allow transfer of data correctly.

```
P1:
  STR R5, [R1]      ; set new data
  DMB                ; ensure that all observers see data before the flag
  STR R0, [R2]      ; send flag indicating data ready
P2:
  WAIT ([R2]==1)    ; wait on flag
  DMB                ; ensure that the load of data is after the flag has been observed
  LDR R5, [R1]
```

Data Synchronization Barrier (DSB)

The DSB instruction has the same effect as the DMB, but in addition to this, it also synchronizes the memory accesses with the full instruction stream, not just other memory accesses. This means that when a DSB is issued, execution stalls until all outstanding explicit memory accesses have completed. When all outstanding reads have completed and the write buffer is drained, execution resumes as normal. There is no effect on pre-fetching of instructions. An example of DSB use is discussed in the following section.

Example: Instruction Cache Maintenance Operations

The multiprocessing extensions require that a DSB is executed by the processor which issued an instruction cache maintenance instruction to ensure its completion; this also ensures that the maintenance operation is completed on all cores within the shareable (not outer-shareable) domain.

ISB is not broadcast, and so does not have an effect on other cores. This requires that other cores perform their own ISB synchronization once it is known that the update is visible, if it is necessary to ensure the synchronization of those other cores.

P1:

```
STR R11, [R1] ; R11 contains a new instruction to be stored in program memory
DCCMVAU R1 ; clean to PoU (Point of Unification) makes it visible to instruction cache
DSB ; ensure completion of the clean on all processors
ICIMVAU R1 ; ensure instruction cache/branch predictor discard stale data
BPIMVA R1
DSB ; ensure completion of the ICache and branch predictor
; Invalidation on all processors
STR R0, [R2] ; set flag to signal completion
ISB ; synchronize context on this processor
BX R1 ; branch to new code
```

P2:

```
WAIT ([R2] == 1) ; wait for flag signaling completion
ISB ; synchronize context on this processor
BX R1 ; branch to new code
```

Instruction Synchronization Barrier (ISB)

This flushes the pipeline and pre-fetch buffer(s) in the processor, so that all instructions following the ISB are fetched from cache or memory, after the instruction has completed. This ensures that the effects of context altering operations (for example, CP15 or ASID changes or TLB or branch predictor operations), executed before the ISB instruction are visible to any instructions fetched after the ISB. This does not in itself cause synchronization between data and instruction caches, but is required as a part of such an operation.

Mismatched Memory Attributes

A physical memory location is accessed with mismatched attributes if all accesses to the location do not use a common definition of all of the following attributes of that location:

- Memory types: strongly-ordered, device, or normal
- Shareability
- Cacheability

The following rules apply when a physical memory location is accessed with mismatched attributes:

1. When a memory location is accessed with mismatched attributes, the only software visible effects are one or more of the following:
 - Uni-processor semantics for reads and writes to that memory location might be lost. This means:
 - A read of the memory location by a thread of execution might not return the value most recently written to that memory location by that thread of execution.
 - Multiple writes to a memory location by a thread of execution which uses different memory attributes might not be ordered in program order.
 - There might be a loss of coherency when multiple threads of execution attempt to access a memory location.
 - There might be a loss of properties derived from the memory type.
2. If the mismatched attributes for a location mean that multiple cacheable accesses to the location might be made with different shareability attributes, then coherency is guaranteed only if each thread of execution that accesses the location with a cacheable attribute performs a clean and invalidate of the location.
3. The possible loss of properties caused by mismatched attributes for a memory location are defined more precisely if all of the mismatched attributes define the memory location as one of:
 - Strongly-ordered memory
 - Device memory
 - Normal inner non-cacheable, outer non-cacheable memory

In these cases, the only possible software-visible effects of the mismatched attributes are one or more of:

- A possible loss of properties derived from the memory type when multiple threads of execution attempt to access the memory location
 - A possible re-ordering of memory transactions to the memory location that use different memory attributes, potentially leading to a loss of coherency or uni-processor semantics. Any possible loss of coherency or uniprocessor semantics can be avoided by inserting DMB barrier instructions between accesses to the same memory location that might use different attributes.
4. If the mismatched attributes for a memory location all assign the same shareability attribute to the location, any loss of coherency within a shareability domain can be avoided. To do so, software must use the techniques that are required for the software management of the coherency of cacheable locations between threads of execution in different shareability domains. This means:
 - If any thread of execution might have written to the location with the write-back attribute, before writing to the location not using the write-back attribute, a thread of execution must invalidate, or clean, the location from the caches. This avoids the possibility of overwriting the location with stale data.

- After writing to the location with the write-back attribute, a thread of execution must clean the location from the caches to make the write visible to external memory.
- Before reading the location with a cacheable attribute, a thread of execution must invalidate the location from the caches to ensure that any value held in the caches reflects the last value made visible in external memory.

In all cases:

- Location refers to any byte within the current coherency granule.
 - A clean and invalidate operation can be used instead of a clean operation, or instead of an invalidate operation.
 - To ensure coherency, all cache maintenance and memory transactions must be completed, or ordered by the use of barrier operations.
5. If all aliases of a memory location that permit write access to the location assign the same shareability and cacheability attributes to that location, and all these aliases use a definition of the shareability attribute that includes all the threads of execution that can access the location, then any thread of execution that reads the memory location using these shareability and cacheability attributes accesses it coherently, to the extent required by that common definition of the memory attributes.

3.2.5 Memory Management Unit (MMU)

The MMU in the Arm architecture involves both memory protection and address translation. The MMU works closely with the L1 and L2 memory systems in the process of translating virtual addresses to physical addresses. It also controls accesses to and from the external memory.

The MMU is compatible with the Virtual Memory System Architecture version 7 (VMSAv7) requirements supporting 4 KB, 64 KB, 1 MB, and 16 MB page table entries and 16 access domains. The unit provides global and application-specific identifiers to remove the requirement for context switch TLB flushes and has the capability for extended permission checks. Please see the *Arm Architecture Reference Manual (Armv7-A)* for a full architectural description of the VMSAv7.

The processor implements the Armv7-A MMU enhanced with security extensions and multiprocessor extensions to provide address translation and access permission checks. The MMU controls table-walk hardware that accesses translation tables in main memory. The MMU enables fine-grained memory system control through a set of virtual-to-physical address mappings and memory attributes held in instruction and data translation look-aside buffers (TLBs).

In summary, the MMU is responsible for the following operations:

- Checking of virtual address and ASID (address space identifier)
- Checking of domain access permissions
- Checking of memory attributes
- Virtual-to-physical address translation
- Support for four page (region) sizes
- Mapping of accesses to cache, or external memory
- Four entries in the main TLB are lockable

MMU Functional Description

The key feature of MMU is the address translation. It translates addresses of code and data from the virtual view of memory to the physical addresses in the real system. It enables tasks or applications to be written in a way which requires them to have no knowledge of the physical memory map of the system, or about other programs which might be running at the same time. This makes programming of applications much simpler, as it enables to use the same virtual memory address space for each. This virtual address space is separate from the actual physical map of memory in the system.

The translation process is based on translation entries stored in the translation table. Refer to [Translation Tables](#) for more details. The two major functional units, shown in [Figure 3-4](#), exist in the MMU to provide address translation automatically based on the table entries:

- The table walker automatically retrieves the correct translation table entry for a requested translation.
- The translation look-aside buffer (TLB) stores recently used translation entries, acting like a cache of the translation table.

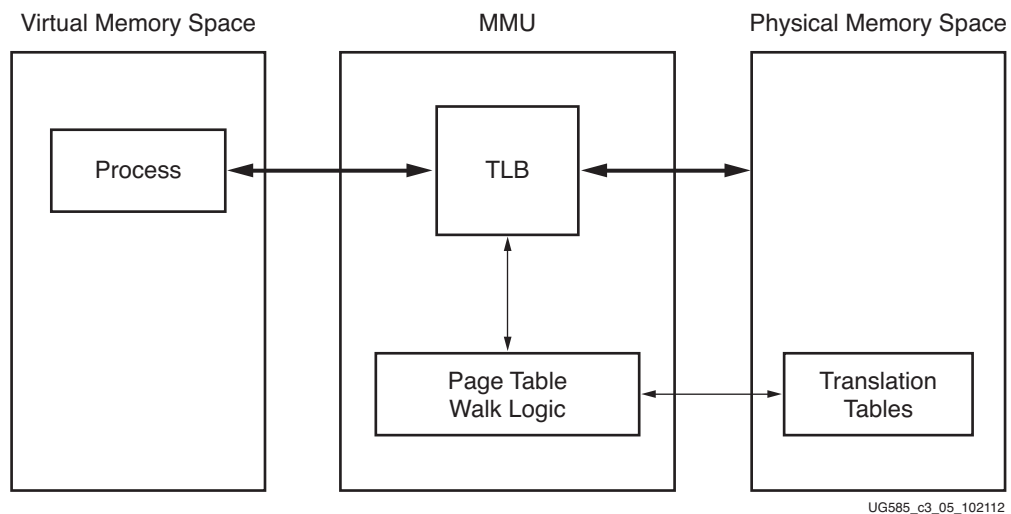

Figure 3-4: MMU Architecture Block Diagram

Translation Tables

The translation of virtual to physical addresses is based on entries in translation tables; they are often called as page tables. These contain a series of entries, each of which describes the physical address translation for part of the memory map. Translation table entries are organized by virtual address. Each virtual address corresponds to exactly one entry in the translation table. In addition to describing the translation of that virtual page to a physical page, they also provide access permissions and memory attributes for that page or block. A single set of translation tables is used to give the translations and memory attributes which apply to instruction fetches and to data reads or writes. The process in which the MMU accesses page tables to translate addresses is known as page table walking.

When developing a table-based address translation scheme, one of the most important design parameters is the memory page size described by each translation table entry. MMU instances

support 4 KB and 64 KB pages, a 1 MB section, and a 16 MB super-section. Using bigger page sizes means a smaller translation table. Using a smaller page size, 4 KB, greatly increases the efficiency of dynamic memory allocation and defragmentation, but it would require one million entries to span the entire 4 GB address range. To reconcile these two requirements, the Cortex-A9 Processor MMU supports multi-level page table architecture with two levels of page table: level 1 (L1) and level 2 (L2), which are discussed in the following sub-sections.

Level 1 Page Tables

Level 1 page table sometimes called as a master page table, which divides the full 4 GB address space into 4,096 equally sized 1 MB sections. The L1 page table therefore contains 4,096 entries, each entry being word sized. Each entry can either hold a pointer to the base address of a level 2 page table or a page table entries for translating a 1 MB section. If the page table entry is translating a 1 MB section, it gives the base address of the 1 MB page in physical memory. The base address of the L1 page table is known as the translation table base address (TTB) and is held within a register in CP15 c2. It must be aligned to a 16 KB boundary.

- An L1 page table entry can be one of four possible types; the least significant two bits [1:0] in the entry define which one of these the entry contains:
- A fault entry that generates an abort exception. This can be either a pre-fetch or data abort, depending on the type of memory access. This effectively indicates virtual addresses which are unmapped.
- A 1 MB section translation entry.
- An entry that points to an L2 page table. This enables a 1 MB piece of memory to be further sub-divided into smaller pages.
- A 16 MB super-section. This is a special kind of 1 MB section entry, which requires 16 entries in the page table.

| | | | | | | | | | | | | | | | | | | | |
|--------------|---------------------------------------|----|---------------------------------|----|----|----|-------|----------|---------|----------|---------|--------|---------------------------------|----|-----|---|---|---|---|
| | 31 | 23 | 19 | 18 | 17 | 16 | 15 | 14 | 11 | 9 | 8 | 4 | 3 | 2 | 1 | 0 | | | |
| | 24 | 20 | | | | | | 13 | 10 | | 7 | | | | | | | | |
| | | | | | | | | 12 | | | 6 | | | | | | | | |
| | | | | | | | | | | | 5 | | | | | | | | |
| Fault | IGNORE | | | | | | | | | | | | | | 0 | 0 | | | |
| Page Table | Page Table Base Address, bits [31:10] | | | | | | | | | | 0 | Domain | SBZ | NS | SBZ | 0 | 1 | | |
| Section | Section Base Address, PA [31:20] | | NS | 0 | nG | S | AP[2] | TEX[2:0] | AP[1:0] | 0 | Domain | XN | C | B | 1 | 0 | | | |
| Supersection | Supersection Base Address PA[31:24] | | Extended Base Address PA[35:32] | | NS | 1 | nG | S | AP[2] | TEX[2:0] | AP[1:0] | 0 | Extended Base Address PA[39:36] | | XN | C | B | 1 | 0 |
| Reserved | Reserved | | | | | | | | | | | | | | 1 | 1 | | | |

UG585_c3_06_092817

Figure 3-5: L1 Page Table Entry Format

The page table entry for a section (or super-section) contains the physical base address used to translate the virtual address. Many other bits listed in the page-table entry, including the access permissions (AP) and memory region attributes TEX, cacheable (C) or bufferable (B) types are examined in the next section.

Example: Generation of a Physical Address from a L1 Page Table Entry

Assume an L1 page table is placed at address 0x12300000. The processor core issues virtual address 0x00100000. The top 12 bits [31:20] define which 1 MB of virtual address space is being accessed. In this case 0x001, so you need to read table entry [1]. Each entry is one word (4 bytes). To get the offset into the table, you must multiply the entry number by entry size: 0x001 * 4 = address offset of 0x004. The address of the entry is 0x12300000 + 0x004 = 0x12300004. So, upon receiving this virtual address from the processor, the MMU reads the word from address 0x12300004.

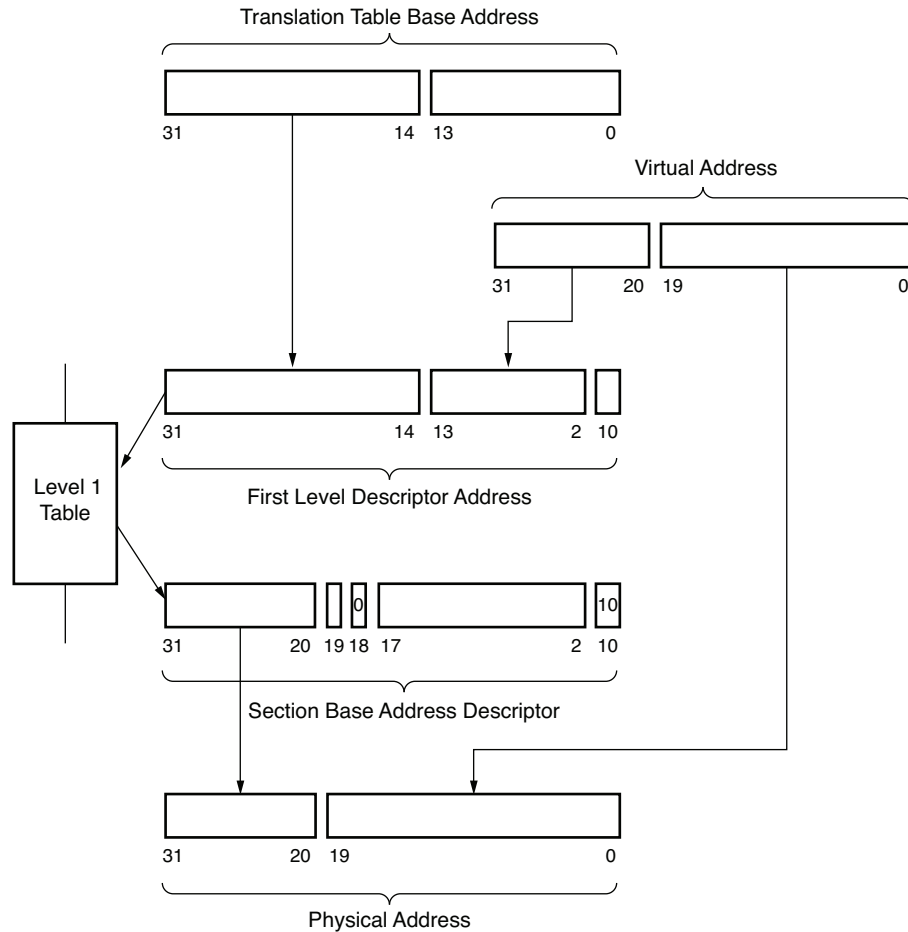

UG585_c3_07_102112

Figure 3-6: Generating a Physical Address from an L1 Page Table Entry

Level 2 Page Tables

An L2 page table has 256 word-sized entries, requires 1KB of memory space and must be aligned to a 1KB boundary. Each entry translates a 4KB block of virtual memory to a 4KB block in physical memory. A page table entry can give the base address of either a 4KB or 64KB page. There are three types of entry used in L2 page tables, identified by the value in the two least significant bits of the entry:

- A large page entry points to a 64 KB page.
- A small page entry points a 4 KB page.
- A fault page entry generates an abort exception if accessed.

| | | | | | | | | | | | | | | | | | | | |
|------------|-------------------------|--|----|----|-----------|----|----|----|-----|-----------|---|----|---|---|---|---|---|---|---|
| | 31 | | 16 | 15 | 14 | 13 | 12 | 11 | 10 | 9 | 8 | 7 | 6 | 5 | 4 | 3 | 2 | 1 | 0 |
| Fault | IGNORE | | | | | | | | | | | | | | | | | 0 | 0 |
| Large Page | Large Page Base Address | | | M | TEX [2:0] | | nG | S | APX | SBZ | | AP | C | B | 0 | 1 | | | |
| Small Page | Small Page Base Address | | | | | | nG | S | APX | TEX [2:0] | | AP | C | B | 1 | M | | | |

UG585_c3_08_1022112

Figure 3-7: L2 Page Table Entry Format

The fields mentioned in Figure 3-7 are discussed in Description of Page Table Entry Fields.

Figure 3-8 summarizes the address translation process when using two layers of page tables. The bits [31:20] of the virtual address are used to index into the 4096-entry L1 page table, where the base address is given by the CP15 TTB register. The L1 page table entry points to an L2 page table, which contains 256 entries. Bits [19:12] of the virtual address are used to select one of those entries which then gives the base address of the page. The final physical address is generated by combining that base address with the remaining bits of the physical address.

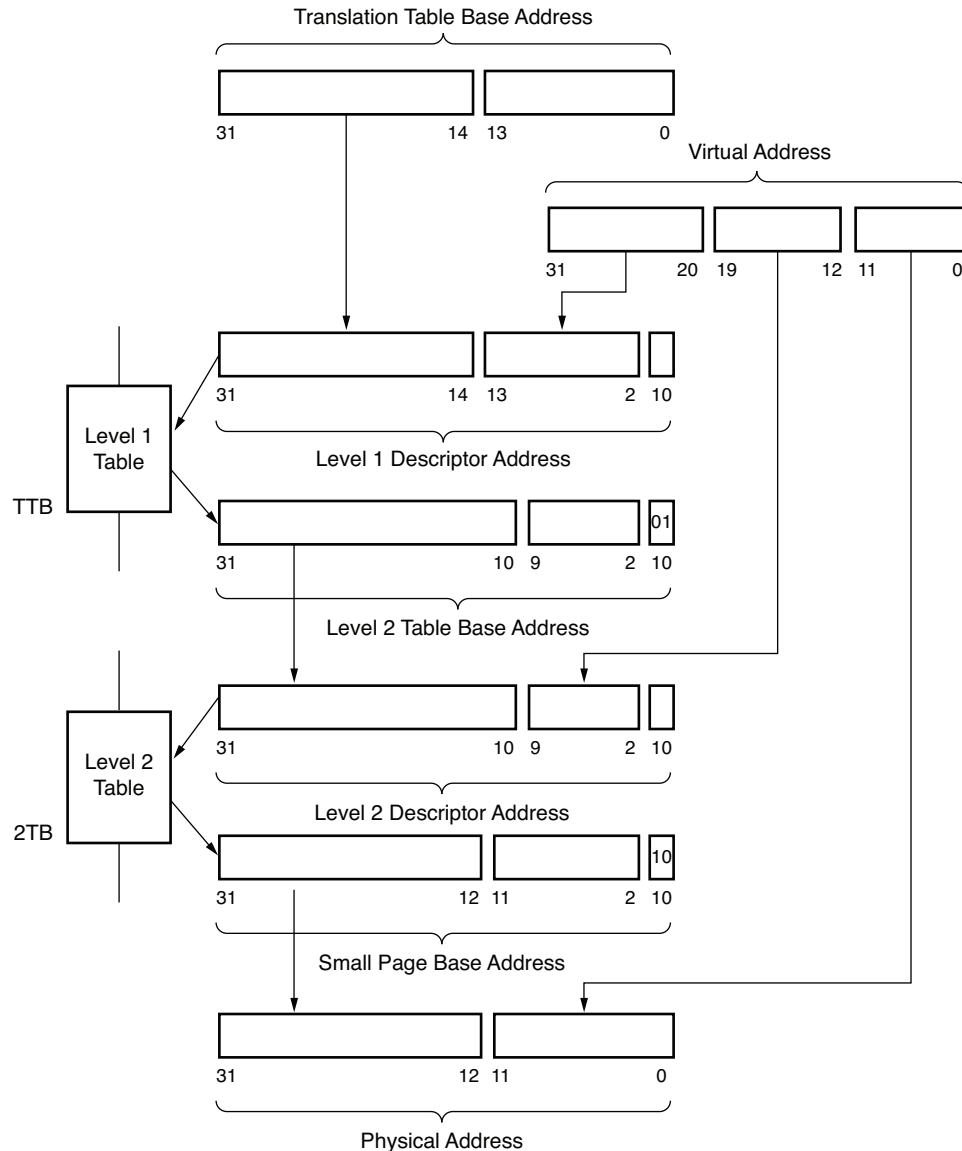

UG585_c3_09_102112

Figure 3-8: Generating a Physical Address from an L2 Page Table Entry

Description of Page Table Entry Fields

Memory Access Permissions (AP and APx)

The access permission (AP and APx) bits in the page table entry give the access permission for a page. An access which does not have the necessary permission (or which faults) is aborted. On a data access, this results in a precise data abort exception. On an instruction fetch, the access is marked as aborted and if the instruction is not subsequently flushed before execution, a pre-fetch abort exception is taken. Information about the address of the faulting location and the reason for the fault is stored in CP15 (the fault address and fault status registers). The abort handler can then take appropriate action. Table 3-2 lists the access permission encodings.

Table 3-2: Access Permission Encodings

| APX | AP1 | AP0 | Privileged | Unprivileged | Description |
|-----|-----|-----|------------|--------------|------------------------|
| 0 | 0 | 0 | No access | No access | Permission fault |
| 0 | 0 | 1 | Read/Write | No access | Privileged access only |
| 0 | 1 | 0 | Read/Write | Read | No user-mode write |
| 0 | 1 | 1 | Read/Write | Read/Write | Full access |
| 1 | 0 | 0 | ~ | ~ | Reserved |
| 1 | 0 | 1 | Read | No access | Privileged Read only |
| 1 | 1 | 0 | Read | Read | Read only |
| 1 | 1 | 1 | ~ | ~~ | Reserved |

Memory Attributes (TEX, C and B bits)

TEX, C, and B bits within the page table entry are used to set the memory attributes of a page and also the cache policies to be used. Memory attributes are discussed in 3.2.4 Memory Ordering, and for various cache policies refer to the *Arm Technical Reference Manual*. Table 3-3 and Table 3-4 summarize these memory attributes.

Table 3-3: Memory Attributes Encodings

| TEX [2:0] | C | B | Description | Memory Type |
|-----------|---|---|---|------------------|
| 0 | 0 | 0 | Strongly-ordered | Strongly ordered |
| 0 | 0 | 1 | shareable device | Device |
| 0 | 1 | 0 | Outer and Inner write through, no allocate on write | Normal |
| 0 | 1 | 1 | Outer and Inner write back, no allocate on write | Normal |
| 1 | 0 | 0 | Outer and Inner non-cacheable | Normal |
| 1 | 1 | 1 | Outer and Inner cacheable | Normal |
| 10 | 0 | 0 | Non-Shareable device | Device |
| 10 | - | - | Reserved | - |
| 11 | - | - | Reserved | - |
| 1XX | Y | Y | Cached memory XX – Outer Policy YY – Inner Policy | Normal |

Table 3-4: Memory Attributes Encodings

| Encoding Bits | | Cache Attribute |
|---------------|---|----------------------------------|
| C | B | |
| 0 | 0 | Non-cacheable |
| 0 | 1 | Write-back, write-allocate |
| 1 | 0 | Write-through, no write-allocate |
| 1 | 1 | Write-back, no write-allocate |

Domains

A domain is a collection of memory regions. Domains are only valid for L1 page table entries. The L1 page table entry format supports 16 domains, and requires the software that defines a translation table to assign each memory region to a domain. The domain field specifies which of the 16 domains the entry is in, and a two-bit field in the Domain Access Control register (DACR) defines the permitted access for each domain. The possible settings for each domain are:

- No access – Any access using the translation table descriptor generates a Domain fault.
- Clients – On an access using the translation table descriptor, the access permission attributes are checked. Therefore, the access might generate a permission fault.
- Managers – On an access using the translation table descriptor, the access permission attributes are not checked. Therefore, the access cannot generate a Permission fault.

Shareable bit (S)

This bit determines whether the translation is for sharable memory. $S = 0$, the memory location is non-shareable, and $S = 1$, it is sharable. For more information, refer to shareable attributes in section [3.2.4 Memory Ordering](#).

Non-Global Region Bit (nG)

The nG bit in the translation table entry permits the virtual memory map to be divided into global and non-global regions. Each non-global region ($nG = 1$) has an associated address space identifier (ASID), which is a number assigned by the OS to each individual task. If the nG bit is set for a particular page, that page is associated with a specific application and is not global. This means that when the MMU performs a translation, it uses both the virtual address and an ASID values. When a page table walk occurs and the TLB is updated and the entry is marked as non-global, the ASID value is stored in the TLB entry in addition to the normal translation information. Subsequent TLB look-ups only match on that entry if the current ASID matches with the ASID that is stored in the entry. This means you can have multiple valid TLB entries for a particular page (marked as non-global), but with different ASID values. This significantly reduces the software overhead of context switches, as it avoids the need to flush the on-chip TLBs.

Execute Never bit (xN)

When a memory location is marked as Execute Never (its XN attribute is set to 1) in a Client domain, instructions are not allowed to fetch/prefetch. Any region of memory that is read-sensitive must be marked as Execute Never to avoid the possibility of a speculative prefetch accessing the memory region. For example, any memory region that corresponds to a read-sensitive peripheral must be marked as Execute Never.

TLB Organization

The Cortex-A9 MMU includes two levels of TLBs which include a unified TLB for both instruction and data and separate micro TLBs for each. The micro TLBs act as the first level TLBs and each have 32 fully associative entries. If an instruction fetch or a load/store address misses in the corresponding micro TLB, the unified or main TLB is accessed. The unified main TLB provides a 2-way associative 2x64 entry table (128 entries) and supports four lockable entries using the lock-by-entry model. The

TLB uses a pseudo round-robin replacement policy to determine which entry in the TLB should be replaced in the case of a miss.

Unlike some other RISC processors that require software to manage the updates of the TLB from the page table that resides in the memory, the main TLB in Cortex-A9 supports hardware page table walks to perform look-ups in the L1 data cache. This allows the page tables to be cached.

The MMU can be configured to perform hardware translation table walks in cacheable regions by setting the IRGN bits in the Translation Table Base registers. If the encoding of the IRGN bits is write-back, then an L1 data cache look-up is performed and data is read from the data cache. If the encoding of the IRGN bits is write-through or non-cacheable, then an access to external memory is performed.

TLB entries can be global, or can be assigned to particular processes or applications using the ASIDs associated with those processes. ASIDs enable TLB entries remain resident during context switches, avoiding the requirement of reloading them subsequently.

Note: The Arm Linux kernel manages the 8-bit TLB ASID space globally across all CPUs instead of on a per-CPU basis. The ASID is incremented for each new process. When the ASID rolls over (ASID = 0) a TLB flush request is sent to both CPUs. However, only the CPU that is in the middle of a context switch immediately updates its current ASID context. The other CPU continues to run using its current pre-rollover ASID until a scheduling interval occurs and then it context switches to a new process.

TLB maintenance and configuration operations are controlled through a dedicated coprocessor, CP15, integrated within the core. This coprocessor provides a standard mechanism for configuring the level one memory system.

Micro TLB

The first level of caching for the page table information is a micro TLB of 32 entries implemented on each of the instruction and data sides. These blocks provide a fully associative look-up of the virtual addresses in a cycle.

The micro TLB returns the physical address to the cache for the address comparison, and also checks the protection attributes to signal either a pre-fetch abort or a data abort.

All main TLB related operations affect both the instruction and data micro TLBs, causing them to be flushed. In the same way, any change of the Context ID register causes the micro TLBs to be flushed. The main or unified TLB, explained in the next section, should be invalidated after a CPU reset and before the MMU is enabled.

Main TLB

The main TLB is the second layer in the TLB structure that catches the misses from the Micro TLBs. It also provides a centralized source for lockable translation entries.

Misses from the instruction and data micro TLBs are handled by a unified main TLB. Accesses to the main TLB take a variable number of cycles, according to competing requests from each of the micro TLBs and other implementation-dependent factors.

Entries in the lockable region of the main TLB are lockable at the granularity of a single entry. As long as the lockable region does not contain any locked entries, it can be allocated with non-locked entries to increase overall main TLB storage size.

Translation Table Base Register 0 and 1

When managing multiple applications with their individual page tables, there is a need to have multiple copies of the L1 page table, one for each application. Each of these are 16 KB in size. Most of the entries are identical in each of the tables, as typically only one region of memory is task-specific, with the kernel space being unchanged in each case. Furthermore, if there is a need to modify a global page table entry, the change is needed in each of the tables.

To help reduce the effect of these problems, a second page table base register can be used. CP15 contains two page table base registers, TTBR0 and TTBR1. A control register (the TTB Control register) is used to program a value in the range 0 to 7. This value (denoted by N) tells the MMU how many upper bits of the virtual address it should check to determine which of the two TTB registers to use. When N is 0 (the default), all virtual addresses are mapped using TTBR0. With N in the range 1-7, the hardware looks at the most significant bits of the virtual address. If the N most significant bits are all zero, TTBR0 is used, otherwise TTBR1 is used.

TTBR0 is used typically for process-specific addresses. On a context switch, TTBR0 is updated to point to the first-level translation table for the new context and TTBCR is updated if this change changes the size of the translation table. This table ranges in size from 128 bytes to 16 KB.

TTBR1 is used for operating system and I/O addresses that do not change on a context switch. The size of this table is always 16 KB.

TLB Match Process

Each TLB entry contains a virtual address, a page size, a physical address, and a set of memory properties. Each is marked as being associated with a particular application space, or as global for all application spaces. A TLB entry matches if bits [31: N] of the modified virtual address (MVA) match, where N is \log_2 of the page size for the TLB entry. It is either marked as global, or the ASID matched the current ASID.

A TLB entry matches when these conditions are true:

- Its virtual address matches that of the requested address.
- Its non-secure TLB ID (NSTID) matches the secure or non-secure state of the MMU request.
- Its ASID matches the current ASID or is global.

The operating system must ensure that, at most, one TLB entry matches at any time. A TLB can store entries based on the following block sizes:

| | |
|-----------------------|------------------------|
| Supersections: | 16 MB blocks of memory |
| Sections: | 1 MB blocks of memory |
| Large pages: | 64 KB blocks of memory |
| Small pages: | 4 KB blocks of memory |

Supersections, sections, and large pages are supported to permit mapping of a large region of memory while using only a single entry in a TLB. If no mapping for an address is found within the TLB, then the translation table is automatically read by hardware and a mapping is placed in the TLB. (The translation table entries are discussed in detail in [Translation Table Base Register 0 and 1, page 86](#))

Memory Access Sequence

When the processor generates a memory access, the MMU:

1. Performs a look-up for the requested virtual address and current ASID and security state in the relevant instruction or data micro TLB.
2. If there is a miss in the micro TLB, performs a look-up for the requested virtual address and current ASID and security state in the main TLB.
3. If there is a miss in main TLB, performs a hardware translation table walk.

The MMU might not find a global mapping or a mapping for the currently selected ASID with a matching non-secure TLB ID (NSTID) for the virtual address in the TLB. In this case, the hardware does a translation table walk if the translation table walk is enabled by the PD0 or PD1 bit in the TTB Control register. If translation table walks are disabled, the processor returns a section translation fault.

If the MMU finds a matching TLB entry, it uses the information in the entry as follows:

1. The access permission bits and the domain determine if the access is enabled. If the matching entry does not pass the permission checks, the MMU signals a memory abort. See the *Arm Architecture Reference Manual (Armv7-A)* for a description of access permission bits, abort types and priorities, and for a description of the Instruction Fault Status register (IFSR) and Data Fault Status register (DFSR).
2. The memory region attributes specified in both the TLB entry and the CP15 c10 remap registers control the cache and write buffer, and determine if the access is:
 - a. Secure or non-secure
 - b. Shared or not
 - c. Normal memory, device, or strongly-ordered
3. The MMU translates the virtual address to a physical address for the memory access.

If the MMU does not find a matching entry, a hardware table walk occurs.

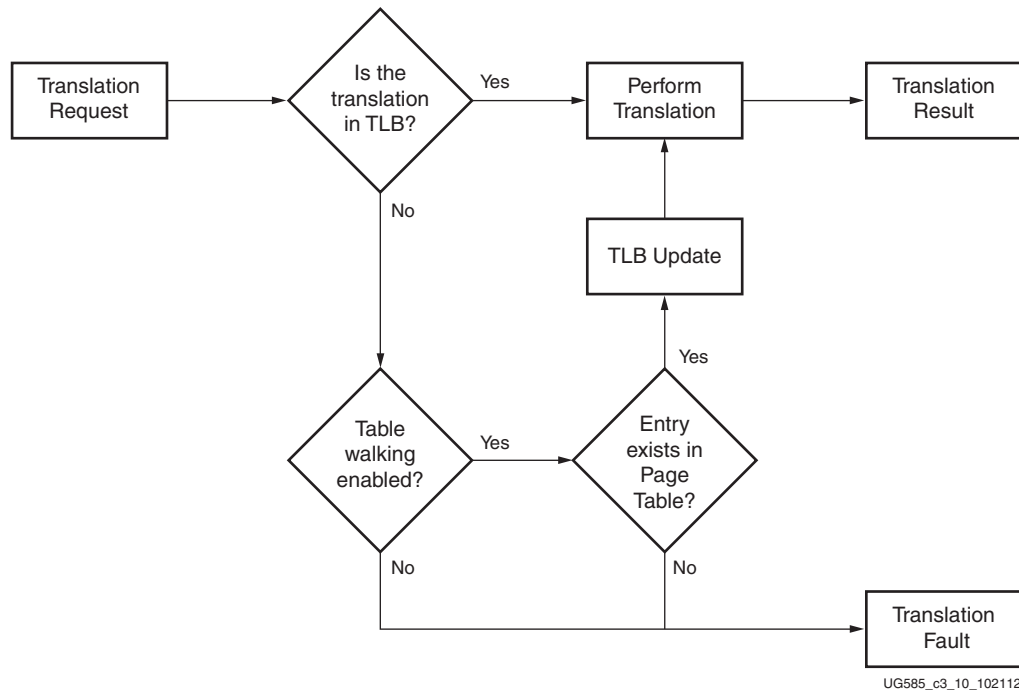

Figure 3-9: Translation Process

TLB Maintenance Operations

The following rules describe the TLB maintenance operations:

- A TLB invalidate operation is complete when all memory accesses using the TLB entries that have been invalidated have been observed by all observers to the extent that those accesses are required to be observed, as determined by the shareability and cacheability of the memory locations accessed by the accesses. In addition, once the TLB invalidate operation is complete, no new memory accesses that can be observed by those observers using those TLB entries will be performed.
- A TLB maintenance operation is only guaranteed to be complete after the execution of a DSB instruction.
- An ISB instruction, or a return from an exception, causes the effect of all completed TLB maintenance operations that appear in program order before the ISB or return from exception to be visible to all subsequent instructions, including the instruction fetches for those instructions.
- An exception causes all completed TLB maintenance operations that appear in the instruction stream before the point where the exception was taken to be visible to all subsequent instructions, including the instruction fetches for those instructions.
- All TLB maintenance operations are executed in program order relative to each other.
- The execution of a Data or Unified TLB maintenance operation is guaranteed not to affect any explicit memory access of any instruction that appears in program order before the TLB maintenance operation. This means no memory barrier instruction is required. This ordering is guaranteed by the hardware implementation.
- The execution of a Data or Unified TLB maintenance operation is only guaranteed to be visible to a subsequent explicit load or store operation after both:

- The execution of a DSB instruction to ensure the completion of the TLB operation.
- A subsequent ISB instruction, or taking an exception, or returning from an exception.
- The execution of an instruction or unified TLB maintenance operation is only guaranteed to be visible to subsequent instruction fetch after both:
 - The execution of a DSB instruction to ensure the completion of the TLB operation.
 - A subsequent ISB instruction, or taking an exception, or returning from an exception.

The following rules apply when writing translation table entries. They ensure that the updated entries are visible to subsequent accesses and cache maintenance operations.

- A write to the translation tables, after it has been cleaned from the cache if appropriate, is only guaranteed to be seen by a translation table walk caused by an explicit load or store after the execution of both a DSB and an ISB. However, it is guaranteed that any writes to the translation tables are not seen by any explicit memory access that occurs in program order before the write to the translation tables.
- If the translation tables are held in write-back cacheable memory, the caches must be cleaned to the point of unification after writing to the translation tables and before the DSB instruction. This ensures that the updated translation table is visible to a hardware translation table walk.
- A write to the translation tables, after it has been cleaned from the cache if appropriate, is only guaranteed to be seen by a translation table walk caused by the instruction fetch of an instruction that follows the write to the translation tables after both a DSB and an ISB.

TLB Lockdown

The TLB supports the TLB lock-by-entry model as described in the *Arm Architecture Reference Manual* (Armv7-A). See the TLB Lockdown register description in the *Arm Cortex-A9 Technical Reference Manual*.

3.2.6 Interfaces

AXI and Coherency Interfaces

Each Cortex-A9 processor provides two 64-bit pseudo AXI master interfaces for independent instruction fetch and data transactions. These interfaces operate at the speed of the processor cores (CPU_6x4x clock) and are capable of sustaining four double-word writes every five processor cycles when copying data across a cached region of memory. The instruction side interface is a read-only interface and does not have the write channel. These interfaces implement an extended version of the AXI protocol that also provides multiple optimizations to the L2 cache including support for L2 pre-fetch hints and speculative memory accesses. These optimizations are explained in more detail in the [L2-Cache](#) section of this chapter.

The AXI transactions are all routed through the SCU to the OCM or the L2 cache controller based on their addresses. Each Cortex-A9 also provides a cache coherency bus (CCB) to the SCU to provide the information required for coherency management between the L1 and L2 caches.

Debug and Trace Interfaces

Each Cortex-A9 processor has a standard 32-bit APB slave port that operates at the CPU_1x clock frequency and is accessed through the debug APB bus master in the SOC debug block. The operation of this block is explained in the corresponding chapter of this document.

The Cortex-A9 processors also include a pair of interfaces for trace generation and cross trigger control. The trace source interface from each core is a 32-bit CoreSight standard ATB master port that operates at the speed of the PS interconnect (CPU_2x clock), and is connected to the funnel in the SOC debug block. Each core also has a 4-bit standard CoreSight cross trigger interface that operates at the interconnect frequency (CPU_2x clock) and is connected to the cross trigger matrix (CTM) in the SOC debug block.

Other Interfaces

Each Cortex-A9 processor has multiple control bits that are driven through the System-Level Control register (SLCR). This includes a 4-bit interface that drives the CoreSight standard security signals and also static configuration signals for controlling CP15 and SW programmability.

There are also other interfaces including the event and interrupt interfaces that are explained later in this chapter.

3.2.7 NEON

- The Cortex-A9 NEON MPE extends the Cortex-A9 functionality to provide support for the Arm v7 advanced SIMD and vector floating-point v3 (VFPv3) instruction sets. The Cortex-A9 NEON MPE supports all addressing modes and data processing operations described in the *Arm Architecture Reference Manual (Armv7-A)*.

The Cortex-A9 NEON MPE features are:

- SIMD vector and scalar single-precision floating-point computation
 - Unsigned and signed integers
 - Single bit coefficient polynomials
 - Single-precision floating-point values
- The operations supported by the NEON co-processor include:
 - Addition and subtraction
 - Multiplication with optional accumulation
 - Maximum or minimum value driven lane selection operations
 - Inverse square-root approximation
 - Comprehensive data-structure load instructions, including register-bank-resident table lookup.
- Scalar double-precision floating-point computation
- SIMD and scalar half-precision floating-point conversion
- 8, 16, 32, and 64-bit signed and unsigned integer SIMD computation

- 8 or 16-bit polynomial computation for single-bit coefficients
- Structured data load capabilities
- Dual issue with Cortex-A9 processor Arm or Thumb instructions
- Independent pipelines for VFPv3 and advanced SIMD instructions
- Large, shared register file, addressable as:
 - Thirty-two 32-bit S (single) registers
 - Thirty-two 64-bit D (double) registers
 - Sixteen 128-bit Q (quad) registers

See the *Arm Architecture Reference Manual (Armv7-A)* for details of the advanced SIMD instructions and the NEON MPE operation.

3.2.8 Performance Monitoring Unit

The Cortex-A9 processor includes a performance monitoring unit (PMU) which provides six counters to gather statistics on the operation of the processor and memory system. Each counter can count any of 58 events available in the Cortex-A9 processor. The PMU counters and their associated control registers are accessible from the internal CP15 interface as well as from the DAP interface. For details, refer to the Performance Monitoring Unit section in the *Arm Cortex-A9 Technical Reference Manual*.

3.3 Snoop Control Unit (SCU)

3.3.1 Summary

The SCU block connects the two Cortex-A9 processors to the memory subsystem and contains the intelligence to manage the data cache coherency between the two processors and the L2 cache. This block is responsible for managing the interconnect arbitration, communication, cache and system memory transfers, and cache coherence for the Cortex-A9 processors. The APU also exposes the capabilities of the SCU to system accelerators that are implemented in the PL through the accelerator coherency port (ACP) interface (see [ACP Interface, page 104](#)). This interface allows PL masters to share and access the processor cache hierarchy. The offered system coherence here not only improves performance but also reduces the software complexity involved in otherwise maintaining software coherency within each OS driver.

The SCU block communicates with each of the Cortex-A9 processors through a cache coherency bus (CCB) and manages the coherency between the L1 and the L2 caches. The SCU supports MESI snooping which provides increased power efficiency and performance by avoiding unnecessary system accesses. The block implements duplicated 4-way associative tag RAMs acting as a local directory that lists coherent cache lines held in the CPU L1 data caches. The directory allows the SCU to check if data is in the L1 data caches with great speed and without interrupting the processors. Also, accesses can be filtered only to the processor that is sharing the data.

The SCU can also copy clean data from one processor cache to another and eliminate the need for main memory accesses to perform this task. Furthermore, it can move dirty data between the processors, skipping the shared state and avoiding the latency associated with the write-back.



IMPORTANT: *It is important to note that the Cortex-A9 does not guarantee coherency between the L1 instructions caches as the processor is not capable of modifying the L1 contents directly.*

3.3.2 Address Filtering

One of the functions of the SCU is to filter transactions that are generated by the processors and the ACP based on their addresses and route them accordingly to the OCM or L2 controller. The granularity of the address filtering within the SCU is 1 MB; therefore, all accesses by the processors or through the ACP whose addresses are within a 1 MB window can only target the OCM or L2 controller. The default setting of the address filtering within the SCU routes all the upper and lower 1M addresses within the 4G address space to the OCM and the rest of the addresses are routed to the L2 controller. Refer to the [SCU Address Filtering](#) section of [Chapter 29, On-Chip Memory \(OCM\)](#) for more information on the SCU address filtering.

3.3.3 SCU Master Ports

Each of the SCU AXI master ports to the L2 or OCM has the following write and read issuing capabilities:

- Write issuing capability:
 - 10 write transactions per processor:
 - 8 non-cacheable writes
 - 2 evictions from L1
 - 2 additional writes for eviction traffic from the SCU
 - 3 more write transactions from the ACP
- Read issuing capability:
 - 14 read transactions per processor:
 - 4 instruction reads
 - 6 linefill reads
 - 4 non-cacheable read
 - 7 more read transactions from the ACP

3.4 L2-Cache

3.4.1 Summary

The L2 cache controller is based on the Arm PL310 and includes an 8-way set-associative 512 KB cache for dual/single Cortex-A9 cores. The L2 cache is physically addressed and physically tagged and supports a fixed 32-byte line size. These are the main features of the L2 cache:

- Supports snoop coherency control utilizing MESI algorithm.
- Offers parity check for L2 cache memory.
- Supports speculative read operations in the SMP mode.
- Provides L1/L2 exclusive mode (that is, data exists in either, but not both).
- Can be locked down by master, line, or way per master.
- Implements 16-entry deep preload engine for loading data into L2 cache memory.
- To improve latency, critical-word-first line-fill is supported.
- Implements pseudo-random victim selection policy with deterministic option.
 - Write-through and write-back.
 - Read allocate, write allocate, read and write allocate.
- The contents of the L2 data and tag RAMs are cleared upon an L2 reset to comply with security requirements.
- The L2 controller implements multiple 256-bit line buffers to improve cache efficiency.
 - Line fill buffers (LFBs) for external memory access to create a complete cache line into L2 cache memory. Four LFBs are implemented for AXI read interleaving support.
 - Two 256-bit line read buffers for each slave port. These buffers hold a line from the L2 cache in case of cache hit.
 - Three 256-bit eviction buffers hold evicted lines from the L2 cache, to be written back to main memory.
 - Three 256-bit store buffers hold bufferable writes before their draining to main memory, or L2 cache. They enable multiple writes to the same line to be merged.
- The controller implements selectable cache pre-fetching within 4k boundaries.
- The L2 cache controller forwards exclusive requests from L1 to DDR, OCM, or external memory.

Note: The SCU does not maintain coherency between instruction and data L1 caches, so this coherency must be maintained by software.

The L2 cache implements TrustZone security extension to offer enhanced OS security. The non-secure (NS) tag bit is added in tag RAM and is used for lookup in the same way as an address bit. The NS tag bit is also added in all of the buffers. The NS bit in tag RAM is used to determine the security level of evictions to DDR and OCM. The controller restricts non-secure accesses for control, configuration, and maintenance registers to restrict access to secure data.

Cache Response

This section describes the general behavior of the cache controller depending on the Cortex-A9 transactions. These are the descriptions for the different type of transactions:

| | |
|-----------------------|---|
| Bufferable | The transaction can be delayed by the interconnect or any of its components for an arbitrary number of cycles before reaching its final destination. This is usually only relevant to writes. |
| Cacheable | The transaction at the final destination does not have to present the characteristics of the original transaction. For writes, this means that several different writes can be merged together. For reads, this means that a location can be pre-fetched or can be fetched just once for multiple read transactions. To determine if a transaction should be cached, this attribute should be used in conjunction with the read allocate and write allocate attributes. |
| Read Allocate | If the transfer is a read and it misses in the cache, then it should be allocated. This attribute is not valid if the transfer is not cacheable. |
| Write Allocate | If the transfer is a write and it misses in the cache, then it should be allocated. This attribute is not valid if the transfer is not cacheable. |

In the Arm architecture, the inner attributes are used to control the behavior of the L1 caches and write buffers. The outer attributes are exported to the L2 or an external memory system.

In the Cortex-A9 processing system (similar to most modern processors), to improve performance and power, many optimizations are performed at many levels of the system which cannot be completely hidden from the outside world and might cause the violation of the expected sequential execution model. Examples of these optimizations are:

- Multi-issue speculative and out-of-order execution.
- Use of load/store merging to minimize the latency of load/stores.
- In a multicore processor, hardware-based cache coherency management can cause cache lines to migrate transparently between cores causing different cores to see updates to cached memory locations in different orders.
- External system characteristics might create additional challenges when external masters are included in the coherent system through the ACP.

Therefore, it is vital to define certain rules to constrain the order in which the memory accesses of one core relate to the surrounding instructions, or could be observed by other cores within a multicore processor system. Typically the memory can be categorized into normal, strongly ordered, and device regions. For more information, refer to section [3.2.4 Memory Ordering](#).

[Table 3-5](#) shows the general behavior of the L2 cache controller in response to Armv7 load/store transaction types that are supported by Cortex-A9.

Table 3-5: Cache Controller Behavior for SCU Requests

| Transaction Type | Armv7 Equivalent | L2 Cache Controller Behavior |
|--|--|--|
| Non-cacheable and non-bufferable | Strongly ordered | <ul style="list-style-type: none"> Read: Not cached in L2, results in memory access. Write: Not buffered, results in memory access. |
| Bufferable only | Device | <ul style="list-style-type: none"> Read: Not cached in L2, results in memory access. Write: Placed in store buffer, not merged, immediately drained to memory. |
| Cacheable but do not allocate | Outer non-cacheable | <ul style="list-style-type: none"> Read: Not cached in L2, results in memory access. Write: Placed in store buffer, write to memory when store buffer is drained. |
| Cacheable write-through, allocate on read | Outer write-through, no write allocate | <ul style="list-style-type: none"> Read hit: Read from L2. Read miss: Line fill to L2. Write hit: Put in store buffer, write to L2 and memory when store buffer is drained. Write miss: Put in store buffer, write to memory when store buffer is drained. |
| Cacheable write-back, allocate on read | Outer write-back, no write allocate | <ul style="list-style-type: none"> Read hit: Read from L2. Read miss: Line fill to L2. Write hit: Put in store buffer, write to L2 when store buffer is drained and mark line as dirty. Write miss: Put in store buffer, write to memory when store buffer is drained. |
| Cacheable write-through, allocate on write | - | <ul style="list-style-type: none"> Read hit: Read from L2. Read miss: Not cached in L2, causes memory access. Write hit: Put in store buffer, write to L2 and memory when store buffer is drained. Write miss: Put in store buffer. When buffer is drained, check if it is full. If not full, request word or line to memory before allocating buffer to L2. Allocation to L2. Write to memory. |
| Cacheable write-back, allocate on write | - | <ul style="list-style-type: none"> Read hit: Read from L2. Read miss: Not cached in L2, causes memory access. Write hit: Put in store buffer, write to L2 when store buffer is drained, and mark line as dirty. Write miss: Put in store buffer. When buffer has to be drained, check if it is full. If it is not full then request word or line to memory before allocating the buffer to L2. Allocation to L2. |

Table 3-5: Cache Controller Behavior for SCU Requests (Cont'd)

| Transaction Type | ArmV7 Equivalent | L2 Cache Controller Behavior |
|---|--|--|
| Cacheable write-through, allocate on read and write | Outer write-through, allocate on both reads and writes | <ul style="list-style-type: none"> • Read hit: Read from L2. • Read miss: Line fill to L2. • Write hit: Put in store buffer, write to L2 and memory when store buffer is drained. • Write miss: Put in store buffer. When buffer has to be drained, check whether it is full. If it is not full then request word or line to memory before allocating the buffer to the L2. Allocation to L2. Write to memory. |
| Cacheable write-back, allocate on read and write | Outer write-back, write allocate | <ul style="list-style-type: none"> • Read hit: Read from L2. • Read miss: Line fill to L2. • Write hit: Put in store buffer, write to L2 when store buffer is drained, and mark line as dirty. • Write miss: Put in store buffer. When buffer has to be drained, check if it is full. If it is not full then request word or line to memory before allocating the buffer to L2. Allocation to L2. |

3.4.2 Exclusive L2-L1 Cache Configuration

In the exclusive cache configuration mode, the L1 data cache of the Cortex-A9 processor and the L2 cache are exclusive. At any time, a given address is cached in either L1 data cache or in the L2 cache, but not in both. This has the effect of increasing the usable space and efficiency of the L2 cache. When exclusive cache configuration is selected:

- Data cache line replacement policy is modified so that the victim line in the L1 always gets evicted to the L2, even if it is clean.
- If a line is dirty in the L2 cache, a read request to this address from the processor causes write-back to external memory and a line-fill to the processor.

Both L1 and L2 caches have to be configured for exclusive caching. Setting the exclusive cache configuration bit 12 in the auxiliary control register for L2 and bit 7 of the ACTLR register in Cortex-A9 configure the L2 and L1 caches to operate exclusive to one another.

For reads, the behavior is as follows:

- For a hit, the line is marked as non-valid (the tag RAM valid bit is reset) and the dirty bit is unchanged. If the dirty bit is set, future accesses can still hit in this cache line, but the line is part of the preferred choice for future evictions.
- For a miss, the line is not allocated into the L2 cache.

For writes, the behavior depends on the value of attributes from the SCU to indicate if the write transaction is an eviction from the L1 memory system and whether it is a clean eviction. AWUSERS[8] attribute indicates an eviction and AWUSERS[9] indicates a clean eviction. The behavior is summarized as follows:

- For a hit, the line is marked dirty unless the AWUSERS[9:8] = b11. In this case, the dirty bit is unchanged.

- For a miss, if the cache line is evicted (AWUSERS[8] is 1), the cache line is allocated and its dirty status depends on if it is evicted dirty or not. If the cache line is evicted dirty (AWUSERS[8] is 0), the cache line is allocated only if it is write allocate.

3.4.3 Cache Replacement Strategy

Bit [25] of the Auxiliary Control register configures the replacement strategy. It can be either round-robin or pseudo-random. The round-robin replacement strategy fills invalid and unlocked ways first; for each line, when ways are all valid or locked, the victim is chosen as the next unlocked way. The pseudo-random replacement strategy fills invalid and unlocked ways first; for each line, when ways are all valid or locked, the victim is chosen randomly between unlocked ways.

When a deterministic replacement strategy is required, the lockdown registers are used to prevent ways from being allocated. For example, since L2 cache is 512 KB and is 8-way set-associative, each way is 64 KB. If a piece of code is required to reside in two ways (128 KB), with a deterministic replacement strategy, ways 1-7 must be locked before the code is filled into the L2 cache. If the first 64 KB of code is allocated into way 0 only, then way 0 must be locked and way 1 unlocked so that the second half of the code can be allocated in way 1.

There are two lockdown registers, one for data and one for instructions. If required, one can separate data and instructions into separate ways of the L2 cache.

3.4.4 Cache Lockdown

The L2 cache controller allows locking down entries by line, by way, or by master (includes both CPU and ACP masters.) Lockdown by line and lockdown by way can be used at the same time; lockdown by line and lockdown by master can also be used at the same time. However, lockdown by master and lockdown by way are exclusive, because lockdown by way is a subset of lockdown by master.

Lockdown by Line

When enabled, all newly allocated cache lines get marked as locked. The controller then considers them as locked and does not naturally evict them. It is enabled by setting bit [0] of the lockdown by the line enable register. Bit [21] of the tag RAM shows the locked status of each cache line.



TIP: An example of when the lockdown by line feature might be enabled is during the time when a critical piece of software code is loaded into the L2 cache.

The unlock all lines background operation enables the unlocking of all lines marked as locked by the lockdown by line mechanism. The status of this operation can be checked by reading the unlock all lines register. While an unlock all lines operation is in progress, you cannot launch a background cache maintenance operation. If attempted, a SLVERR error is returned.

Lockdown by Way

The L2 cache is 8-way set-associative and allows users to lock the replacement algorithm on a way basis, enabling the set count to be reduced from 8-way all the way down to direct mapped. The

32-bit cache address consists of the following fields: [Tag Field], [Index Field], [Word Field], [Byte Field].

When a cache lookup occurs, the index defines where to look in the cache ways. The number of ways defines the number of locations with the same index referred to as a set. Therefore, an 8-way set associative cache has eight locations where an address with index A can exist. There are 2^{11} or 2,048 indices in the 512K L2 cache.

Lockdown format C, as the *Arm Architecture Reference Manual (Armv7-A)* describes, provides a method to restrict the replacement algorithm used for allocations of cache lines within a set. This method enables:

- Fetch of code or load data into the L2 cache
- Protection from being evicted because of other accesses
- This method can also be used to reduce cache pollution.

The lockdown register in the L2 cache controller is used to lock any of the eight ways in the L2 cache. To apply lockdown, you set each bit to 1 to lock each respective way. For example, set bit [0] for Way 0, bit [1] for Way 1.

Lockdown by Master

The lockdown by master feature is a superset of the lockdown by way feature. It enables multiple masters to share the L2 cache and makes the L2 cache behave as though these masters have dedicated smaller L2 caches. This feature enables you to reserve ways of the L2 cache to specific master IDs.

There are eight Instruction and eight Data Lock-Down registers in the L2 cache controller (0xF8F02900 to 0xF8F0293C) and each register is associated with one of the master IDs identified by AR/WUSERSx[7:5] bits. Each register contains a 16-bit DATALOCK or INSTRLOCK field. By setting any of the 16 bits in those fields to 1, the user can lock down that specific way for its corresponding master ID.

The L2 cache controller lockdown by master is only able to distinguish up to eight different masters. However, there are up to 64 AXI master IDs from the Cortex-A9 MP core. Table 3-6 shows how the 64 master ID values are grouped into eight lockable groups.

Table 3-6: Lockdown by Master ID Group

| ID Group | Transaction Sources | L2 DATA/INSTRLOCKxxx |
|------------|---|----------------------|
| A9 Core 0 | All read/write and instruction fetch requests from Core 0 | 000 |
| A9 Core 1 | All read/write and instruction fetch requests from Core 1 | 001 |
| A9 Core 2 | Reserved for future | 010 |
| A9 Core 3 | Reserved for future | 011 |
| ACP Group0 | ACP requests with ID = {000, 001} | 100 |
| ACP Group1 | ACP requests with ID = {010, 011} | 101 |

Table 3-6: Lockdown by Master ID Group (Cont'd)

| ID Group | Transaction Sources | L2 DATA/INSTRLOCKxxx |
|------------|-----------------------------------|----------------------|
| ACP Group2 | ACP requests with ID = {100, 101} | 110 |
| ACP Group3 | ACP requests with ID = {110, 111} | 111 |

3.4.5 Enabling and Disabling the L2 Cache Controller

The L2 cache is disabled by default and can be enabled by setting bit 0 of the L2 cache control register independently of the L1 caches. When the cache controller block is not enabled, depending on their addresses, transactions pass through to the DDR memory or the main interconnect on the cache controller master ports. The address latency introduced by the disabled cache controller is one cycle in the slave port from the SCU plus one cycle in the master ports.

3.4.6 RAM Access Latency Control

The L2 cache data and tag RAMs use the same clock as the Cortex-A9 processors; however, it is not feasible to access these RAMs in a single cycle when the clock runs at its maximum speed. To address this issue, the L2-cache controller provides a mechanism to adjust the latencies for the write access, read access, and setup of both RAM arrays by respectively setting bits [10:8], [6:4], and [2:0] of its tag RAM and data RAM latency control registers. The default value for these fields is 3'b111 for both registers, which corresponds to the maximum latency of eight CPU_6x4x cycles for the three attributes of each RAM array. Because these large latencies result in very poor cache performance, the software should program the attributes as follows:

- Set the latencies for the three tag RAM attributes to 2 by writing 3'b001 to bits [10:8], [6:4], and [2:0] of the tag RAM latency control register.
- Set the latencies for the write access and setup of the data RAM to 2 by writing 3'b001 to bits [10:8] and [2:0] of the data RAM latency control register.
- Set the read access latency of the data RAM to 3 by writing 3'b010 to bits [6:4] of the data RAM latency control register.

3.4.7 Store Buffer Operation

Two buffered write accesses to the same address and the same security bit cause the first write access to be overridden if the controller does not drain the store buffer after the first access. The store buffer has merging capabilities, so it merges successive writes to the same line address into the same buffer slot. This means that the controller does not drain the slots as soon as they contain data, but rather waits for other potential accesses that target the same cache line. The store buffer draining policy is as follows. Slave port refers to the port from the SCU to the L2 cache controller:

- The store buffer slot is immediately drained if targeting device memory area.
- The store buffer slots are drained as soon as they are full.
- The store buffer is drained at each strongly-ordered read occurrence in the slave port.
- The store buffer is drained at each strongly ordered write occurrence in the slave port.
- If the three slots of the store buffer contain data, the least recently accessed slot is drained.

- If a hazard is detected with one store buffer slot, it is drained to resolve the hazard. Hazards can occur when data is present in the cache buffers, but not yet present in the cache RAM or external memory.
- The store buffer slots are drained when a locked transaction is received by the slave port.
- The store buffer slots are drained when a transaction targeting the configuration registers is received by the slave port.

Merging condition is based on address and security attribute. Merging takes place only when data is in the store buffer and it is not draining.

When a write-allocate cacheable slot is drained, misses in the cache, and is not full, the store buffer sends a request through the master ports to the main interconnects or DDR to complete the cache line. The corresponding master port sends a read request through the interconnects and provides data to the store buffer in return. When the slot is full, it can be allocated into the cache.

3.4.8 Optimizations Between Cortex-A9 and L2 Controller

To improve performance, the SCU interface to the L2 controller, and partially the interface to the on-chip memory controller (OCM), implement several optimizations:

- Early write response
- Pre-fetch hints
- Full line of zero write
- Speculative reads of the Cortex-A9 MPCore processor

These optimizations apply to the transfers from the processor and do not include the ACP.

Early Write Response

During the write transaction from the Cortex-A9 to the L2 cache controller, the write response from the L2 controller is normally returned to the SCU only when the last data beat has arrived at the L2 controller. This optimization enables the L2 controller to send the write response of certain write transactions as soon as the store buffer accepts the write address and allows the Cortex-A9 processor to provide a higher bandwidth for writes. This feature is disabled by default and you can enable it by setting the Early BRESP enable bit in the auxiliary control register for the L2 controller. The Cortex-A9 does not require any programming to enable this feature. OCM does not support this feature and its write responses are generated normally.

Pre-fetch Hints

When the Cortex-A9 processor is configured to run in SMP mode, the automatic data pre-fetchers implemented in the CPUs issue special read accesses to the L2 cache controller. These special reads are called pre-fetch hints. When the L2 controller receives such pre-fetch hints, it allocates the targeted cache line into the L2 cache for a miss without returning any data back to the Cortex-A9 processor. You can enable the pre-fetch hint generation by the Cortex-A9 processors through one of the two following methods:

1. Enabling the L2 pre-fetch hint feature by setting bit [1] of the ACTLR register. When enabled, this feature sets the Cortex-A9 processor to automatically issue L2 pre-fetch hint requests when it detects regular fetch patterns on a coherent memory.
2. Use of PLE (pre-load engine) operations. When this feature is used in the Cortex-A9 processor, the PLE issues a series of L2 pre-fetch hint requests at the programmed addresses.

No additional programming of the L2 Controller is required. Application of the pre-fetch hints to the OCM memory space does not cause any action because, unlike caches, transfer of data into OCM RAM requires explicit operations by software.

Full Line of Zero Write

When this feature is enabled, the Cortex-A9 processor can write entire non-coherent cache lines of zeroes to the L2 cache, using a single write command cycle. This provides a performance improvement as well as some power savings. The Cortex-A9 processor is likely to use this feature when a CPU is executing a memset routine to initialize a particular memory area.

This feature is disabled by default and can be enabled by setting the “Full Line of Zero” enable bit of the auxiliary control register for the L2 controller and the enable bit in the Cortex-A9 ACTLR register. Care must be taken if this feature is enabled because correct behavior relies on consistent enabling in both the Cortex-A9 processor and the controller.

To enable this feature, the following steps must be performed:

1. Enable the full line of zero feature in the L2 controller.
2. Enable the L2 cache controller.
3. Enable the full line of zero feature in the Cortex-A9.

The cache controller does not support strongly ordered write accesses with this feature. The feature is also supported by the OCM if it is enabled in the Cortex-A9

Speculative Reads of the Cortex-A9

This is a feature unique to the Cortex-A9 MP configuration and can be enabled using a dedicated software control bit in the SCU Control register. For this feature, the Cortex-A9 has to be in the SMP mode through the use of the SMP bit in the ACTLR register; however, the L2 controller does not require any specific settings. When the speculative read feature is enabled, on coherent line fills, the SCU speculatively issues read transactions to the controller in parallel with its tag lookup. The controller does not return data on these speculative reads and only prepares data in its line read buffers.

If the SCU misses, it issues a confirmation line fill to the controller. The confirmation is merged with the previous speculative read in the controller and enables the controller to return data to the L1 cache sooner than a L2 cache hit. If the SCU hits, the speculative read is naturally terminated in the L2 controller, either after a certain number of cycles, or when a resource conflict exists. The L2 controller informs the SCU when a speculative read ends, either by confirmation or termination.

3.4.9 Pre-fetching Operation

The pre-fetch operation is the capability of attempting to fetch cache lines from memory in advance, to improve system performance. To enable the pre-fetch feature, you set bit 29 or 28 of the auxiliary or pre-fetch control register. When enabled, if the slave port from the SCU receives a cacheable read transaction, a cache lookup is performed on the subsequent cache line. Bits [4:0] of the pre-fetch control register provide the address of the subsequent cache line. If a miss occurs, the cache line is fetched from external memory, and allocated to the L2 cache.

By default, the pre-fetch offset is $5 \times b00000$. For example, if S0 receives a cacheable read at address 0×100 , the cache line at address 0×120 is pre-fetched. Pre-fetching the next cache line might not necessarily result in optimal performance. In some systems, it might be better to pre-fetch more in advance to achieve better performance. The pre-fetch offset enables this by setting the address of the pre-fetched cache line to $\text{Cache Line} + 1 + \text{Offset}$. The optimal value of the pre-fetch offset depends on the external memory read latency and on the L1 read issuing capability. The pre-fetch mechanism is not launched for a 4 KB boundary crossing.

Pre-fetch accesses can use a large number of the address slots in the controller master ports. This prevents non-prefetch accesses being serviced and affects performance. To counter this effect, the controller can drop pre-fetch accesses. This can be controlled using bit 24 of the Pre-fetch Control register. When enabled, if a resource conflict exists between pre-fetch and non-pre-fetch accesses in the controller master ports, pre-fetch accesses are dropped. When data corresponding to these dropped pre-fetch accesses returns from the external memory, it is discarded and is not allocated into the L2 cache.

3.4.10 Programming Model

The following applies to the registers used in the L2 cache controller:

- The cache controller is controlled through a set of memory-mapped registers. The memory region for these registers must be defined with strongly ordered or device memory attributes in the L1 page tables.
- The reserved bits in all registers must be preserved; otherwise, unpredictable behavior of the device might occur.
- All registers support read and write accesses unless otherwise stated in the relevant text. A write updates the contents of a register and a read returns the contents of the register.
- All writes to registers automatically perform an initial cache sync operation before proceeding.

Initialization Sequence

As an example, a typical cache controller start-up programming sequence consists of the following register operations:

- Write 0×020202 to the register at $0 \times F8000A1C$. This is a mandatory step.
- Write to the auxiliary, tag RAM latency, data RAM latency, pre-fetch, and Power Control registers using a read-modify-write to set up global configurations:
 - Associativity and way size

- Latencies for RAM accesses
- Allocation policy
- Pre-fetch and power capabilities
- Secure write to invalidate by way, offset `0x77C`, to invalidate all entries in cache:
 - Write `0xFFFF` to `0x77C`
 - Poll the cache maintenance register until invalidate operation is complete.
- If required, write to register 9 to lock down D and lock down I.
- Write to the interrupt clear register to clear any residual raw interrupts set.
- Write to the interrupt mask register if it is desired to enable interrupts.
- Write to control register 1 with the LSB set to 1 to enable the cache.

If a write is performed to the auxiliary, tag RAM latency, or data RAM latency control register with the L2 cache enabled, a SLVERR (error) results. The L2 cache must be disabled by writing to the control register before writing to these registers.

Cache Lockdown by Way Sequence

These are the steps to be followed for locking code by way:

1. Ensure the code to be locked is in a cacheable memory region. This can be done by programming page table entry for the region with appropriate memory attributes. Refer to [Memory Attributes](#).
2. Ensure the code to lockdown is in a non-cacheable memory region. For example, the region can be marked as a strongly ordered region.

The following is the sequence that needs to be implemented in lockdown routine:

3. Disable the interrupts.
4. Clean and invalidate the entire L2 cache. This step is for ensuring that the code to be locked is not loaded into L2 cache.
5. Find the number of ways required for loading code based on the code size.
6. Unlock the calculated ways and lock all the ways remaining. This is done by writing into data lockdown registers. Refer to the *PL310 L2 Cache Controller Document* for information on these registers.
7. Load the code into the L2 cache using PLD instruction. The PLD instruction always generates data references; this is the reason for using data lockdown registers. For more information on PLD instruction, refer to the Armv7 TRM. This step loads the code into unlocked ways.
8. Lock the loaded ways and unlock the remaining ways by writing into data lockdown registers.
9. Enable Interrupts.

TIP: To check for whether the code is really locked into L2 cache, generate more references to the code that has been locked. These references can be monitored by the L2 cache instruction hit event. For more information on the available events of L2 cache and their initialization, refer to the *PL310 L2 Cache Controller document*. This event initialization should be done prior to code locking. So more the

references to code, more the instruction hits. For example, the code that is locked can be called from a timer interrupt handler which generates references as per the number of interrupts programmed.

3.5 APU Interfaces

3.5.1 PL Co-processing Interfaces

ACP Interface

The accelerator coherency port (ACP) is a 64-bit AXI slave interface on the SCU that provides an asynchronous cache-coherent access point directly from the PL to the Cortex-A9 MP-Core processor subsystem. A range of system PL masters can use this interface to access the caches and the memory subsystem exactly the way the APU processors do to simplify software, increase overall system performance, or improve power consumption. This interface acts as a standard AXI slave and supports all standard read and write transactions without any additional coherency requirements placed on the PL components. Therefore, the ACP provides cache-coherent access from the PL to Arm caches while any memory local to the PL are non-coherent with the Arm.

Any read transactions through the ACP to a coherent region of memory interact with the SCU to check whether the required information is stored within the processor L1 caches. If it is, the data is returned directly to the requesting component. If it misses in the L1 cache, then there is also the opportunity to hit in L2 cache before finally being forwarded to the main memory. For write transactions to any coherent memory region, the SCU enforces coherence before the write is forwarded to the memory system. The transaction can also optionally allocate into the L2 cache, removing the power and performance impact of writing through to the off-chip memory.

ACP Requests

The read and write requests performed on the ACP behave differently depending on whether the request is coherent or not. This behavior is as follows:

ACP coherent read requests: An ACP read request is coherent when $ARUSER[0] = 1$ and $ARCACHE[1] = 1$ alongside $ARVALID$. In this case, the SCU enforces coherency. When the data is present in one of the Cortex-A9 processors, the data is read directly from the relevant processor and returned to the ACP port. When the data is not present in any of the Cortex-A9 processors, the read request is issued on one of the SCU AXI master ports, along with all its AXI parameters, with the exception of the locked attribute.

ACP non-coherent read requests: An ACP read request is non-coherent when $ARUSER[0] = 0$ or $ARCACHE[1] = 0$ alongside $ARVALID$. In this case, the SCU does not enforce coherency, and the read request is directly forwarded to one of the available SCU AXI master ports to the L2 cache controller or OCM.

ACP coherent write requests: An ACP write request is coherent when $AWUSER[0] = 1$ and $AWCACHE[1] = 1$ alongside $AWVALID$. In this case, the SCU enforces coherency. When the data is present in one of the Cortex-A9 processors, the data is first cleaned and invalidated from the

relevant CPU. When the data is not present in any of the Cortex-A9 processors, or when it has been cleaned and invalidated, the write request is issued on one of the SCU AXI master ports, along with all corresponding AXI parameters with the exception of the locked attribute.

Note: The transaction can optionally allocate into the L2 cache if the write parameters are set accordingly.

ACP non-coherent write requests: An ACP write request is non-coherent when $AWUSER[0] = 0$ or $AWCACHE[1] = 0$ alongside $AWVALID$. In this case, the SCU does not enforce coherency and the write request is forwarded directly to one of the available SCU AXI master ports.

ACP Usage

The ACP provides a low latency path between the PS and the accelerators implemented in the PL when compared with a legacy cache flushing and loading scheme. Steps that must take place in an example of a PL-based accelerator are as follows:

1. The CPU prepares input data for the accelerator within its local cache space.
2. The CPU sends a message to the accelerator using one of the general purpose AXI master interfaces to the PL.
3. The accelerator fetches the data through the ACP, processes the data, and returns the result through the ACP.
4. The accelerator sets a flag by writing to a known location to indicate that the data processing is complete. Status of this flag can be polled by the processor or could generate an interrupt.

Table 3-7 shows ACP read and write behavior based on current cache status. Clearly, access latency is small when cache hits occur.

When compared to a tightly-coupled coprocessor, ACP access latencies are relatively long. Therefore, ACP is not recommended for fine-grained instruction level acceleration. On the other hand, for coarse-grain acceleration such as video frame-level processing, ACP does not have a clear advantage over traditional memory-mapped PL acceleration because the transaction overhead is small relative to the transaction time, and might potentially cause undesirable cache thrashing. ACP is therefore optimal for medium-grain acceleration, such as block-level crypto accelerator and video macro-block level processing.

Table 3-7: ACP Read and Write Behavior

| Action | Description |
|--------------------------|---|
| ACP read – I (invalid) | SCU fetches data from external memory through one of two AXI master interfaces. Data is forwarded to the ACP directly. It does not affect the CPU L1 cache state. |
| ACP read – M (modified) | SCU fetches data from L1 cache with M status. It does not affect the L1 cache state. |
| ACP read – S (shared) | SCU fetches data from any L1 cache with S status. It does not affect the L1 cache state. |
| ACP read – E (exclusive) | SCU fetches data from the L1 cache with E status. It does not affect the L1 cache state. |
| ACP write – I (invalid) | Data is written to external memory through one of two AXI master interfaces. It does not affect the CPU L1 cache state. |

Table 3-7: ACP Read and Write Behavior (Cont'd)

| Action | Description |
|---------------------------|---|
| ACP write – M (modified) | Data in L1 cache with M status is flushed out to external memory first. After that, ACP data is written into external memory interface. L1 cache previously with M status is changed to I status. If the SCU overwrites the entire cache line, L1 cache flush is skipped. |
| ACP write – S (shared) | Data is written to external memory through one of two AXI master interfaces. L1 cache previously with S status is changed to I state |
| ACP write – E (exclusive) | Data is written to external memory through one of two AXI master interfaces. Any L1 cache previously with S status is changed to I status. |

ACP Limitations

The accelerator coherency port (ACP) has these limitations:

- Exclusive accesses are not allowed for coherent memory.
- Locked accesses are not allowed for coherent memory.
- Optimized coherent read and write transfers when byte strobes are not all set. More specifically, write transactions with AWLEN = 3, AWSIZE = 3, and WSTRB not equal to 11111111 are not supported and can cause the L1 cache line in the CPUs to be corrupted. Potential user workarounds include:
 - Perform smaller, non-optimized, and coherent accesses.
 - Perform a read/modify/write sequence where the write has all byte strobes set.
 - Align user software data structures to avoid needing to deassert any write strobes, overwriting the bytes instead.
- Continuous access to the OCM over the ACP can starve accesses from other AXI masters. To allow access from other masters, the ACP bandwidth to OCM should be moderated to less than the peak OCM bandwidth. This can be accomplished by regulating burst sizes to less than eight 64-bit words.
- Blocks, such as PCIe, which prioritize write requests over read requests should not be connected to the ACP port, as they might create deadlock. Connecting these devices to the other the GP and HP AXI ports does not manifest the mentioned deadlock issue.

Note: The Xilinx HDL wrapper around the PS7 primitive provides a function to flag the third limitation (cache lines being corrupted). If enabled, the Xilinx ACP adapter watches for transactions that could potentially corrupt the cache and generate an error response to the master that is requesting the write request. The write transaction is allowed to proceed to the ACP interface, so the possibility of cache corruption is *NOT* eliminated. The master is notified of the possible issue to take the appropriate action. The ACP adapter can also generate an interrupt signal to the CPUs, which can be used by the software to detect such a situation.

Event Interface

The event bus provides a low-latency and direct mechanism to transfer status and implement a wake mechanism between the APU and the PL. The event input and output signals on this interface use toggle signaling in which an event is communicated by toggling the signal to the opposite logic level on both edges. The event bus includes these signals:

| | |
|-----------------------------|--|
| EVENTEVENTO | A toggle output signal indicating that either CPU is executing the SEV instruction. SEV (Send Event) causes an event to be signaled to all CPUs within a multi-processor system. |
| EVENTEVENTI | A toggle input signal that wakes up either one or both CPUs if they are in a standby state initiated by the WFE instruction. |
| EVENTSTANDBYWFE[1:0] | Two-level output signals indicating the state of the two CPUs. A bit is asserted if the corresponding CPU is in standby state following the execution of the WFE (wait for event) instruction. If the event register is currently set, WFE clears it and returns immediately. If the event register is not set, the processor suspends execution until an event is signaled by another processor using Send Event. |
| EVENTSTANDBYWFI[1:0] | Two-level output signals indicating the state of the two CPUs. A bit is asserted if the corresponding CPU is in standby state following the execution of the WFI (wait for interrupt) instruction. |

The event bus can be used to implement PL-based accelerators. The event output can be used to trigger an ACP accelerator to read from a predefined address. Further on in the process, the event input can be used to communicate that the data has been written back over the ACP and is ready to be consumed by a CPU. A detailed description of this example follows:

1. CPU0 generates the data that is required by the accelerator in the L1/L2 cache. This data can contain both commands and information to be processed.
2. CPU0 issues an SEV (send event) instruction, causing EVENTEVENTO to toggle to the PL. The signal is connected to an accelerator IP implemented in the PL.
3. CPU0 next issues a WFE (wait For event) instruction, placing the CPU in a lower-power standby state. This is reflected in the EVENTSTANDBYWFE[0] status output to the PL.
4. The accelerator notices the toggled EVENTEVENTO signal and realizes that CPU0 is waiting. The accelerator fetches data from a prearranged address and data format through the ACP interface and begins processing.
5. After writing the result data back through the ACP, the accelerator asserts the EVENTEVENTI input to indicate that processing is complete and wakes up CPU0.
6. CPU0 wakes from its standby state, which is reflected in the EVENTSTANDBYWFE[0] output, and CPU0 continues execution using the processed data.

3.5.2 Interrupt Interface

The PS general interrupt controller (GIC) supports 64 interrupt input lines that are driven from other blocks within the PS or the PL. Six of the 64 interrupt inputs are driven from within the APU. These include the L1 parity fail, L2 interrupt (all reasons), and PMU (performance monitor unit) interrupt. The interrupt output of the GIC drives either the IRQ or FIQ inputs of each of the Cortex-A9 processors. The selection as to which processor is interrupted is accomplished through an SCU register within the APU. [Table 3-8](#) defines the interrupts specific to the APU.

Table 3-8: APU Interrupts

| Interrupt | Description |
|-----------|---|
| 32 | Any of the L1 instruction cache, L1 data cache, TLB, GHB, and BTAC parity errors from CPU 0 |
| 33 | Any of the L1 instruction cache, L1 data cache, TLB, GHB, and BTAC parity errors from CPU 1 |
| 34 | Any errors, including parity errors, from the L2 controller |
| 92 | Any of the parity errors from SCU generate a third interrupt |
| 37 | Performance monitor unit (PMU) of CPU0 |
| 38 | Performance monitor unit (PMU) of CPU1 |

3.6 Support for TrustZone

TrustZone is hardware that is built into all Zynq-7000 SoC devices. For more information, see *Programming ARM TrustZone Architecture on the Xilinx Zynq-7000 SoC* (UG1019).

3.7 Application Processing Unit (APU) Reset

3.7.1 Reset Functionality

The APU supports several reset modes that enable you to reset different parts of the block independently. Applicable resets and their functions are as follows:

The APU supports different reset modes that enable the user to reset different parts of the block independently. Applicable resets and their functions are as follows:

| | |
|-----------------------|---|
| Power-on Reset | The power-on reset or cold reset is applied when the power is first applied to the system or through the PS_POR_B device pin. In this reset mode, both CPUs, the NEON coprocessors, and the debug logic is reset. |
| System Reset | A system reset initializes the Cortex-A9 processor and the NEON coprocessors, apart from the debug logic. Break points and watch points are retained during this reset. This reset is applied through the PS_SRST_B device pin. |
| Software Reset | A software or warm reset initializes the Cortex-A9 processor and the NEON coprocessors, apart from the debug logic. Break points and watch points are retained during this reset. Processor reset is typically used for resetting a system that has been operating for some time. This reset is applied through the A9_CPU_RST_CTRL.A9_RSTx register. |

- System Debug Reset** This reset is similar to the software reset; however, it is triggered through the JTAG interface.
- Debug Reset** This reset initializes the debug logic in a Cortex-A9 processor, including break point and watch point values. It is triggered through the JTAG interface.

Note: The APU in Zynq-7000 SoC devices does not support an independent reset for the NEON coprocessors.

Note: Unlike the POR or system resets, when the user applies a software reset to a single processor, the user must stop the associated clock, de-assert the reset, and then restart the clock. During a system or POR reset, hardware automatically takes care of this. Therefore, a CPU cannot run the code that applies the software reset to itself. This reset needs to be applied by the other CPU or through JTAG or PL. Assuming the user wants to reset CPU0, the user must to set the following fields in the slcr.A9_CPU_RST_CTRL (address 0x000244) register in the order listed:

1. A9_RST0 = 1 to assert reset to CPU0
2. A9_CLKSTOP0 = 1 to stop clock to CPU0
3. A9_RST0 = 0 to release reset to CPU0
4. A9_CLKSTOP0 = 0 to restart clock to CPU0
5. A9 Watchdog Reset (AWDT)– Resets the core. The reset controller monitors the reset sequence.

3.7.2 APU State After Reset

Table 3-9 summarizes the state of the APU after the reset. For a CPU, including its L1 caches and MMU, this reset is a CPU reset that can be triggered through all resets. The reset to the SCU and the L2 cache can occur as a result of a system software reset, external system reset, debug system reset, and watchdog timer resets.

Table 3-9: APU State after Reset

| Function | State after Reset |
|--|--|
| CPU1 | Kept in a WFE state while executing code located at address 0xFFFFFE00 to 0xFFFFFFFF0 |
| L1 Caches Validation | Disabled Unknown (requires invalidation prior to usage) |
| MMUs | Disabled |
| SCU | Disabled |
| Address Filtering | Upper and lower 1M addresses within the 4G address space are mapped to OCM and the rest of the addresses are routed to the L2 |
| L2 Cache L2 wait states Validation | Disabled Tag RAM and Data RAM wait states are both 7-7-7 for setup latency, write access latency, and read access latency Unknown (requires invalidation prior to usage) |

3.8 Power Considerations

The system-level power considerations are described in [Chapter 24, Power Management. System Modules, page 671](#) includes additional information on the APU.

3.8.1 Introduction

The APU incorporates many features to improve its dynamic power efficiency:

- Either of the CPUs can be put in the standby mode and started up when an event or interrupt is detected.
- The L2 cache can be put in the standby mode when the CPUs are in that mode.
- Clock gating is extensively used in all the sub-blocks within the module. Dynamic clock gating in the Cortex-A9 can be enabled in the CP15 power control register. If enabled, the clocks to the CPU internal blocks are dynamically disabled in idle periods. The gated blocks include the integer core, the system control block, and the data engine.
- Accurate branch and return prediction reduces the number of incorrect instruction fetch and decode operations.
- Physically addressed caches reduce the number of cache flushes and refills, saving energy in the system.
- The CPUs implement micro TLBs for local address translation which reduces the power consumed in translation and protection look-ups.
- The tag RAMs and data RAMs are accessed sequentially to eliminate accesses to the unwanted data RAMs, and thus minimize unnecessary power consumption.
- To reduce power consumption in the L1 caches, the number of full cache reads is reduced by taking advantage of the sequential nature of memory accesses. If a cache read is sequential to the previous cache read, and the address is within the same cache line, only the data RAM set that was previously read is accessed.
- If an instruction loop fits in four BTAC entries, then instruction cache accesses are turned off to lower power consumption.
- The clock to the NEON engine is dynamically controlled by the CPU and the engine gets clocked only when a NEON instruction is issued.

Note: Power to the APU or any of its sub-blocks cannot be turned off while the PS is powered on.

3.8.2 Standby Mode

In the standby mode of operation, the device is still powered-up, but most of its clocks are gated off. This means that the processor is in a static state and the only power drawn is due to leakage currents and the clocking of the small amount of logic which looks out for the wake-up condition.

This mode is entered using either the WFI (wait for interrupt) or WFE (wait for event) instructions. It is recommended that a DSB memory barrier be used before WFI or WFE, to ensure that pending memory transactions complete.

The processor stops execution until a wake-up event is detected. The wake-up condition is dependent on the entry instruction. For WFI, an interrupt or external debug request wakes the processor. For WFE, several specified events exist, including another processor in an MP system executing the SEV instruction. A request from the SCU can also wake up the clock for a cache coherency operation in an MP system. This means that the cache of a processor which is in standby state continues to be coherent with caches of other processors. A processor reset always forces the processor to exit from the standby condition.

The standby mode in the SCU is enabled by setting the corresponding bit in the `mpcore.SCU_CONTROL_REGISTER`. When this feature is enabled, the SCU stops its internal clocks when the following conditions are met:

- CPUs are in WFI mode
- No pending requests on the ACP
- No remaining activity in the SCU

The SCU resumes normal operation when a CPU leaves WFI mode or a request on the ACP occurs.

The standby mode of the L2 cache controller can be enabled by setting bit 0 of the L2 controller power control register (`l2cpl310.reg15_power_ctrl`). This mode is used in conjunction with the wait state (WFI/WFE) of the processor that drives the controller. Before entering the wait state, the Cortex-A9 processor must set its status field in the CPU power status register of the SCU to signal its entering standby mode. The Cortex-A9 processor then executes a WFI or WFE entry instruction. The SCU CPU power status register bits can also be read by a Cortex-A9 processor exiting low-power mode to determine its state before executing its reset setup.

If the MP system is in the standby mode, the SCU signals to the L2 cache controller to gate its clock and the controller honors that when the L2 becomes idle. Any transaction from the SCU to the L2 restarts the clock and triggers a response with 2-3 clock cycles of delay.

3.8.3 Dynamic Clock Gating in the L2 Controller

Bit 1 of the L2 Controller Power Control register enables the dynamic clock gating feature within the controller. If this feature is enabled, the cache controller stops its clock when it is idle for 32 clock cycles. The controller stops the clock until there is a transaction on its slave interface from the SCU. If this interface detects a transaction, it restarts its clock and accepts the new transaction with two to three cycles of delay.

3.9 CPU Initialization Sequence

Typically, these are the following steps to initialize CPU:

1. Set the vector base address register.
2. Invalidate L1 caches, TLB, branch predictor array (refer to [Initialization of L1 Caches](#)).
3. Invalidate L2 cache.

4. Prepare page tables and load into physical memory. (For more information on page tables, refer to [Translation Table Base Register 0 and 1](#).)
5. Setup the stack.
6. Load the page table base address into the translation table base register (refer to [Translation Table Base Register 0 and 1](#)).
7. Set the MMU enable bit of the system control register.
8. Initialize and enable L2 cache (refer to [L2-Cache](#), section [3.4.10 Programming Model](#)).
9. Enable L1 caches by writing to the system control register.
10. Jump to entry of application.

3.10 Implementation-Defined Configurations

The Zynq-7000 SoC APU has implemented some configurations which determine the reset values of some CP15 register fields. [Table 3-10](#) shows these configuration signals and the reset values of the corresponding register fields.

Table 3-10: Implementation Configuration Signals and Register Fields

| Configuration Signal | Register Fields | Bits | Reset Value |
|----------------------|---------------------------------|--------|-------------|
| MAXCLKLATENCY | c15.Power control register | [10:8] | b111 |
| CFGEND | c1.SCTLR.EE | [25] | b0 |
| CFGNMFI | c1.SCTLR.NMFI | [27] | b1 |
| TEINIT | c1.SCTLR.TE | [30] | b0 |
| VINITHI | c1.SCTLR.V | [13] | b0 |
| CLUSTERID | c0.MPIDR.ClustreID | [11:8] | b0000 |
| (none) | c0.REVIDR | [31:0] | 0x0 |
| (none) | c0.AIDR (Auxiliary ID register) | [31:0] | 0x0 |

System Addresses

4.1 Address Map

The comprehensive system level address map is shown in [Table 4-1](#). The shaded entries indicate that the address range is reserved and should not be accessed. [Table 4-2](#) identifies reserved address ranges.

Table 4-1: System-Level Address Map

| Address Range | CPUs and ACP | AXI_HP | Other Bus Masters ⁽¹⁾ | Notes |
|---------------------------------------|--------------|--------|----------------------------------|---|
| 0000_0000 to 0003_FFFF ⁽²⁾ | OCM | OCM | OCM | Address not filtered by SCU and OCM is mapped low |
| | DDR | OCM | OCM | Address filtered by SCU and OCM is mapped low |
| | DDR | | | Address filtered by SCU and OCM is not mapped low |
| | | | | Address not filtered by SCU and OCM is not mapped low |
| 0004_0000 to 0007_FFFF | DDR | | | Address filtered by SCU |
| | | | | Address not filtered by SCU |
| 0008_0000 to 000F_FFFF | DDR | DDR | DDR | Address filtered by SCU |
| | | DDR | DDR | Address not filtered by SCU ⁽³⁾ |
| 0010_0000 to 3FFF_FFFF | DDR | DDR | DDR | Accessible to all interconnect masters |
| 4000_0000 to 7FFF_FFFF | PL | | PL | General Purpose Port #0 to the PL, M_AXI_GP0 |
| 8000_0000 to BFFF_FFFF | PL | | PL | General Purpose Port #1 to the PL, M_AXI_GP1 |
| E000_0000 to E02F_FFFF | IOP | | IOP | I/O Peripheral registers, see Table 4-6 |
| E100_0000 to E5FF_FFFF | SMC | | SMC | SMC Memories, see Table 4-5 |
| F800_0000 to F800_0BFF | SLCR | | SLCR | SLCR registers, see Table 4-3 |
| F800_1000 to F880_FFFF | PS | | PS | PS System registers, see Table 4-7 |
| F890_0000 to F8F0_2FFF | CPU | | | CPU Private registers, see Table 4-4 |
| FC00_0000 to FDFE_FFFF ⁽⁴⁾ | Quad-SPI | | Quad-SPI | Quad-SPI linear address for linear mode |
| FFFC_0000 to FFFF_FFFF ⁽²⁾ | OCM | OCM | OCM | OCM is mapped high |
| | | | | OCM is not mapped high |

Notes:

1. The other bus masters include the S_AXI_GP interfaces, Device configuration interface (DevC), DAP controller, DMA controller and the various controllers with local DMA units (Ethernet, USB and SDIO).
2. The OCM is divided into four 64 KB sections. Each section is mapped independently to either the low or high addresses ranges, but not both at the same time. In addition, the SCU can filter addresses destined for the OCM low address range to the DDR DRAM controller instead. A detailed discussion of the OCM is explained in [Chapter 29, On-Chip Memory \(OCM\)](#).
3. For each 64 KB section mapped to the high OCM address range via slcr.OCM_CFG[RAM_HI] which is not also part of the SCU address filtering range will be aliased for CPU and ACP masters at a range of (0x000C_0000 to 0x000F_FFFF). See [Chapter 29, On-Chip Memory \(OCM\)](#) for more information.
4. When a single device is used, it must be connected to QSPI 0. In this case, the address map starts at FC00_0000 and goes to a maximum of FCFE_FFFF (16 MBs). When two devices are used, both devices must be the same capacity. The address map for two devices depends on the size of the devices and their connection configuration. For the shared 4-bit stacked I/O bus, the QSPI 0 device starts at FC00_0000 and goes to a maximum of FCFE_FFFF (16 MBs). The QSPI 1 device starts at FD00_0000 and goes to a maximum of FDFE_FFFF (another 16 MBs). If the first device is less than 16 MBs in size, then there will be a memory space hole between the two devices. For the 8-bit dual parallel mode (8-bit bus), the memory map is continuous from FC00_0000 to a maximum of FDFE_FFFF (32 MBs).

Table 4-2: System-Level Address Map (Reserved Addresses)

| Address Range | CPUs and ACP | AXI_HP | Other Bus Masters ⁽¹⁾ | Notes |
|----------------------------|--------------|--------|----------------------------------|----------|
| C000_0000 to DFFF_FFFF | | | | Reserved |
| E030_0000 to E0FF_FFFF | | | | Reserved |
| E600_0000 to F7FF_FFFF | | | | Reserved |
| F800_0C00 to F800_0FFF | | | | Reserved |
| F881_0000 to F889_0FFF | | | | Reserved |
| F8F0_3000 to FBFF_FFFF | | | | Reserved |
| FE00_0000 to FFFB_FFFF | | | | Reserved |
| 0xF889_E000 to 0xF88F_FFFF | | | | Reserved |

PL AXI Interface Note

There are two general purpose interconnect ports that go to the PL, M_AXI_GP{1,0}. Each port is addressable by masters in the PS and each port occupies 1 GB of system address space in the ranges specified in [Table 4-1](#). The M_AXI_GP addresses are directly from the PS; they are not remapped on their way to the PL. The addresses outside of these ranges are not presented to the PL.

Execute-In-Place Capable Devices

The following devices are execute-in-place capable:

- DDR
- OCM
- SMC SRAM/NOR
- Quad-SPI (linear addressing mode)
- M_AXI_GP{1, 0} (PL block RAM or external memory with a suitable PL slave controller)

4.2 System Bus Masters

The CPUs and AXI_ACP see the same memory map, except the CPUs have a private bus to access their private timer, interrupt controller, and shared L2 cache / SCU registers. The AXI_HP interfaces provide high bandwidth to the DDR DRAM and OCM memory. The other system bus masters include:

- DMA controller, see [Chapter 9, DMA Controller](#)
- Device configuration interface (DevC), see [Chapter 6, Boot and Configuration](#)
- Debug access port (DAP), see [Chapter 28, System Test and Debug](#)
- PL bus master controllers attached to AXI general purpose ports (S_AXI_GP[1:0]), see [Chapter 5, Interconnect](#) and [Chapter 21, Programmable Logic Description](#)
- AHB bus master ports with local DMA units (Ethernet, USB, and SDIO)

4.3 SLCR Registers

The System-Level Control registers (SLCR) consist of various registers that are used to control the PS behavior. These registers are accessible via the central interconnect using load and store instructions. The detailed descriptions for each register can be found in [Appendix B, Register Details](#). A summary of the SLCR registers with their base addresses is shown in [Table 4-3](#).

Table 4-3: SLCR Register Map

| Register Base Address | Description | Reference |
|-----------------------|--|---|
| F800_0000 | SLCR write protection lock and security | |
| F800_0100 | Clock control and status | See Chapter 25, Clocks |
| F800_0200 | Reset control and status | See Chapter 26, Reset System |
| F800_0300 | APU control | See Chapter 3, Application Processing Unit |
| F800_0400 | TrustZone control | See UG1019, <i>Programming Arm TrustZone Architecture on the Xilinx Zynq-7000 SoC</i> |
| F800_0500 | CoreSight SoC debug control | See Chapter 28, System Test and Debug |
| F800_0600 | DDR DRAM controller | See Chapter 10, DDR Memory Controller |
| F800_0700 | MIO pin configuration | See Chapter 2, Signals, Interfaces, and Pins |
| F800_0800 | MIO parallel access | See Chapter 2, Signals, Interfaces, and Pins |
| F800_0900 | Miscellaneous control | See Chapter 29, On-Chip Memory (OCM) |
| F800_0A00 | On-chip memory (OCM) control | See Chapter 29, On-Chip Memory (OCM) |
| F800_0B00 | I/O buffers for MIO pins (GPIOB) and DDR pins (DDRIOB) | See Chapter 2, Signals, Interfaces, and Pins |

4.4 CPU Private Bus Registers

The registers shown in [Table 4-4](#) are only accessible by the CPU on the CPU private bus. The accelerator coherency port (ACP) cannot access any of the private CPU registers. The private CPU registers are used to control subsystems in the APU.

Table 4-4: CPU Private Register Map

| Register Base Address | Description |
|------------------------|--|
| F890_0000 to F89F_FFFF | Top-level interconnect configuration and Global Programmers View (GPV) |
| F8F0_0000 to F8F0_00FC | SCU control and status |
| F8F0_0100 to F8F0_01FF | Interrupt controller CPU |
| F8F0_0200 to F8F0_02FF | Global timer |
| F8F0_0600 to F8F0_06FF | Private timers and private watchdog timers |
| F8F0_1000 to F8F0_1FFF | Interrupt controller distributor |
| F8F0_2000 to F8F0_2FFF | L2-cache controller |

4.5 SMC Memory

The SMC memories are accessed via a 32-bit AHB bus (see [Table 4-5](#)). The SMC control registers are listed in [Table 4-6](#). Refer to [Chapter 11, Static Memory Controller](#) for information on the functionality of the NAND and SRAM/NOR controllers.

Table 4-5: SMC Memory Address Map

| Register Base Address | Description |
|-----------------------|--|
| E100_0000 | SMC NAND Memory address range |
| E200_0000 | SMC SRAM/NOR CS 0 Memory address range |
| E400_0000 | SMC SRAM/NOR CS 1 Memory address range |

7z007s and 7z010 Device Notice

The 7z010 dual core and 7z007s single core devices have CLG225 packages with a limited number of pins. For SMC, only an 8-bit NAND interface is supported. These devices do not support the NOR/SRAM interface or a 16-bit NAND interface.

4.6 PS I/O Peripherals

The I/O Peripheral registers are accessed via a 32-bit APB bus, shown in [Table 4-6](#).

Table 4-6: I/O Peripheral Register Map

| Register Base Address | Description |
|-----------------------|--------------------------------|
| E000_0000, E000_1000 | UART Controllers 0, 1 |
| E000_2000, E000_3000 | USB Controllers 0, 1 |
| E000_4000, E000_5000 | I2C Controllers 0, 1 |
| E000_6000, E000_7000 | SPI Controllers 0, 1 |
| E000_8000, E000_9000 | CAN Controllers 0, 1 |
| E000_A000 | GPIO Controller |
| E000_B000, E000_C000 | Ethernet Controllers 0, 1 |
| E000_D000 | Quad-SPI Controller |
| E000_E000 | Static Memory Controller (SMC) |
| E010_0000, E010_1000 | SDIO Controllers 0, 1 |

4.7 Miscellaneous PS Registers

The PS system registers are accessed via a 32-bit AHB bus (see [Table 4-7](#)).

Table 4-7: PS System Register Map

| Register Base Address | Description (Acronym) | Register Set |
|-----------------------|---|--------------|
| F800_1000, F800_2000 | Triple timer counter 0, 1 (TTC 0, TTC 1) | ttc. |
| F800_3000 | DMAC when secure (DMAC S) | dmac. |
| F800_4000 | DMAC when non-secure (DMAC NS) | dmac. |
| F800_5000 | System watchdog timer (SWDT) | swdt. |
| F800_6000 | DDR memory controller | ddrc. |
| F800_7000 | Device configuration interface (DevC) | devcfg. |
| F800_8000 | AXI_HP 0 high performance AXI interface w/ FIFO | afi. |
| F800_9000 | AXI_HP 1 high performance AXI interface w/ FIFO | afi. |
| F800_A000 | AXI_HP 2 high performance AXI interface w/ FIFO | afi. |
| F800_B000 | AXI_HP 3 high performance AXI interface w/ FIFO | afi. |
| F800_C000 | On-chip memory (OCM) | ocm. |
| F800_D000 | eFuse ⁽¹⁾ | - |
| F800_F000 | Reserved | Reserved |

Table 4-7: PS System Register Map (Cont'd)

| Register Base Address | Description (Acronym) | Register Set |
|-----------------------|-------------------------|--------------|
| F880_0000 | CoreSight debug control | cti. |

Notes:

1. One-time programmable non-volatile memory used to support RSA authentication of the FSBL.

Interconnect

5.1 Introduction

The interconnect located within the PS comprises multiple switches to connect system resources using AXI point-to-point channels for communicating addresses, data, and response transactions between master and slave clients. This Arm AMBA 3.0 interconnect implements a full array of the interconnect communications capabilities and overlays for QoS, debug, and test monitoring. The interconnect manages multiple outstanding transactions and is architected for low-latency paths for the Arm CPUs and, for the PL master controllers, a high-throughput and cache coherent datapaths.

5.1.1 Features

The interconnect is the primary mechanism for data communications. The following summarizes the interconnect features:

- The interconnect is based on AXI high performance datapath switches:
 - Snoop control unit
 - L2 cache controller
- Interconnect switches based on Arm NIC-301
 - Central interconnect
 - Master interconnect for slave peripherals
 - Slave interconnect for master peripherals
 - Memory interconnect
 - OCM interconnect
 - AHB and APB bridges
- PS-PL Interfaces
 - AXI_ACP, one cache-coherent slave port in the PL connected to the PS APU coherency slave port.
 - AXI_HP, four high performance, high bandwidth slave port in the PL that becomes a master port on the PS AXI interconnect.
 - AXI_GP, four general purpose ports (two master ports and two slave ports)

5.1.2 Block Diagram

This section discusses the block diagram for all the interconnect, including the interconnect masters, the snoop control unit, central interconnect, master interconnect, slave interconnect, memory interconnect, and OCM interconnect. [Figure 5-1](#) shows the block diagram for the interconnect.

Interconnect Masters

The interconnect masters are shown at the top of [Figure 5-1](#), and include:

- CPUs and accelerator coherency port (ACP)
- High performance PL interfaces, AXI_HP{3:0}
- General purpose PL interfaces, AXI_GP{1:0}
- DMA controller
- AHB masters (I/O peripherals with local DMA units)
- Device configuration (DevC) and debug access port (DAP)

Snoop Control Unit (SCU)

The functionality of the snoop control unit is described in [Chapter 3, Application Processing Unit](#). The address filtering feature of the SCU makes the SCU function like a switch from the perspective of the traffic from its AXI slave ports to its AXI master ports.

Central Interconnect

The central interconnect is the core of the Arm NIC301-based interconnect switches.

Master Interconnect

The master interconnect switches the low-to-medium speed traffic from the central interconnect to M_AXI_GP ports, I/O peripherals (IOP) and other blocks.

Slave Interconnect

The slave interconnect switches the low-to-medium speed traffic from S_AXI_GP ports, DevC and DAP to the central interconnect.

Memory Interconnect

The memory interconnect switches the high speed traffic from the AXI_HP ports to DDR DRAM and on-chip RAM (through another interconnect).

OCM Interconnect

The OCM interconnect switches the high speed traffic from the central interconnect and the memory interconnect.

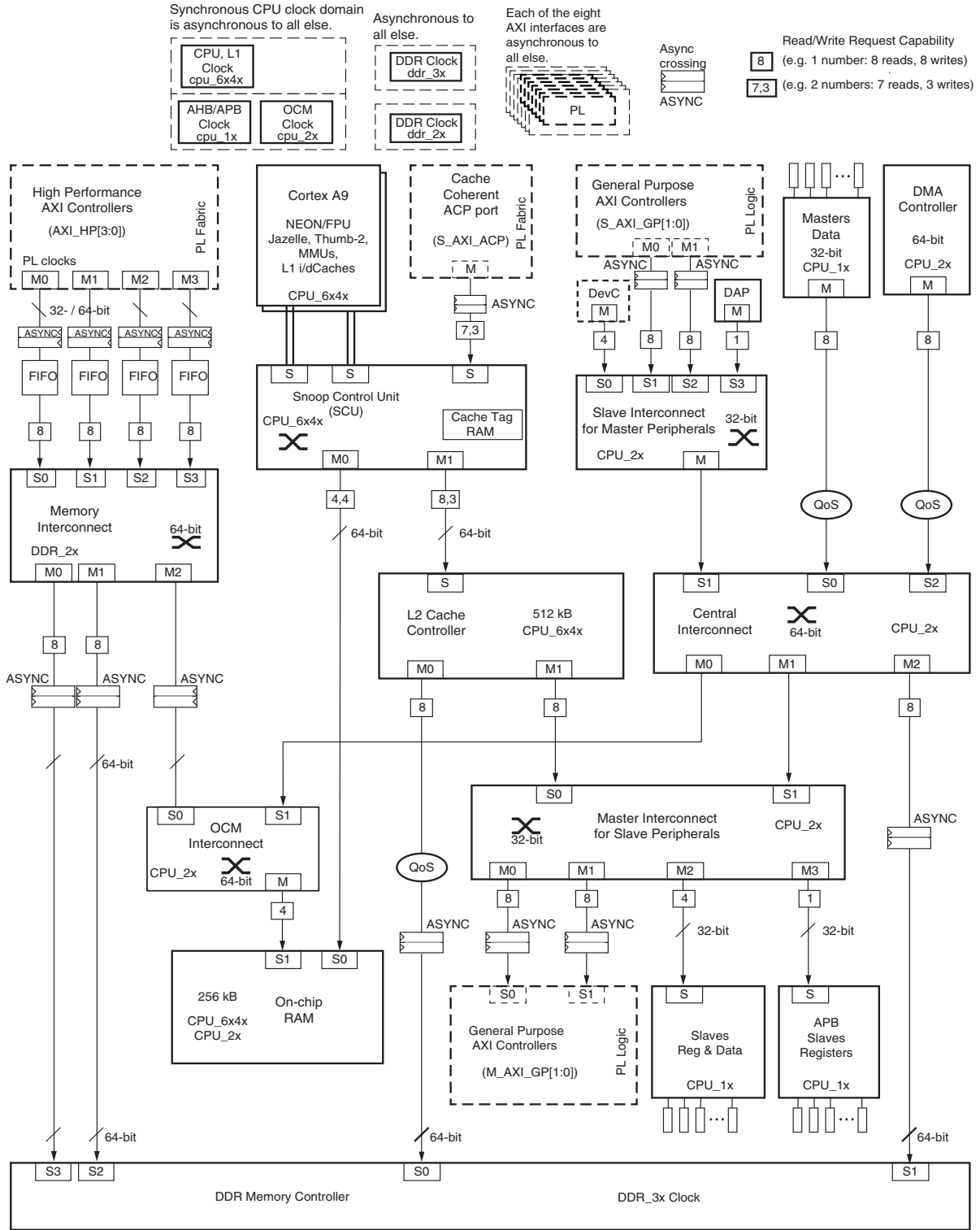

UG585_c5_01_120813

Figure 5-1: Interconnect Block Diagram

L2 Cache Controller

The functionality of the L2 cache controller is described in [Chapter 3, Application Processing Unit](#). The address filtering feature of the L2 cache controller makes the L2 cache controller function like a switch from the perspective of the traffic from its AXI slave ports to its AXI master ports.

Interconnect Slaves

The interconnect slaves are shown toward the bottom of [Figure 5-1](#). The Interconnect slaves include:

- On-chip RAM (OCM)
- DDR DRAM
- General purpose PL interfaces, M_AXI_GP{1:0}
- AHB slaves (IOP with local DMA units)
- APB slaves (programmable registers in various blocks)
- GPV (programmable registers of the interconnect, not shown in [Figure 5-1](#))

5.1.3 Datapaths

[Table 5-1](#) lists the major datapaths used by the PS interconnect.

Table 5-1: Interconnect Datapaths

| Source | Destination | Type | Clock at source | Clock at destination | Sync or Async ⁽¹⁾ | Data width | R/W Request Capability | Advanced QoS |
|---------------------|----------------------|------|-----------------|----------------------|------------------------------|------------|----------------------------|--------------|
| CPU | SCU | AXI | CPU_6x4x | CPU_6x4x | Sync | 64 | 7, 12 | - |
| AXI_ACP | SCU | AXI | SAXIACPCLK | CPU_6x4x | Async | 64 | 7, 3 | - |
| AXI_HP | FIFO | AXI | SAXIHPnACLK | DDR_2x | Async | 32/64 | 14-70, 8-32 ⁽²⁾ | - |
| S_AXI_GP | Master interconnect | AXI | SAXIGPnACLK | CPU_2x | Async | 32 | 8, 8 | - |
| DevC | Master interconnect | AXI | CPU_1x | CPU_2x | Sync | 32 | 8, 4 | - |
| DAP | Master interconnect | AHB | CPU_1x | CPU_2x | Sync | 32 | 1, 1 | - |
| AHB masters | Central interconnect | AXI | CPU_1x | CPU_2x | Sync | 32 | 8, 8 | X |
| DMA controller | Central interconnect | AXI | CPU_2x | CPU_2x | Sync | 64 | 8, 8 | X |
| Master interconnect | Central interconnect | AXI | CPU_2x | CPU_2x | Sync | 64 | - | - |
| FIFO | Memory interconnect | AXI | DDR_2x | DDR_2x | Sync | 64 | 8, 8 | - |
| SCU | L2 Cache | AXI | CPU_6X4x | CPU_6x4x | Sync | 64 | 8, 3 | - |

Table 5-1: Interconnect Datapaths (Cont'd)

| Source | Destination | Type | Clock at source | Clock at destination | Sync or Async ⁽¹⁾ | Data width | R/W Request Capability | Advanced QoS |
|----------------------|--------------------|----------------|-----------------|----------------------|------------------------------|------------|------------------------|--------------|
| Memory interconnect | OCM interconnect | AXI | DDR_2x | CPU_2x | Async | 64 | - | - |
| Central interconnect | OCM interconnect | AXI | CPU_2x | CPU_2x | Sync | 64 | - | - |
| L2 Cache | Slave interconnect | AXI | CPU_6x4x | CPU_2x | Sync | 64 | 8, 8 | - |
| Central interconnect | Slave interconnect | AXI | CPU_2x | CPU_2x | Sync | 64 | - | - |
| SCU | On-chip RAM | AXI | CPU_6x4x | CPU_2x | Sync | 64 | 4, 4 | - |
| OCM interconnect | On-chip RAM | AXI | CPU_2x | CPU_2x | Sync | 64 | 4, 4 | - |
| Slave interconnect | APB slaves | APB | CPU_2x | CPU_1x | Sync | 32 | 1, 1 | - |
| Slave interconnect | AHB slaves | AXI | CPU_2x | CPU_1x | Sync | 32 | 4, 4 | - |
| Slave interconnect | AXI_GP | AXI | CPU_2x | MAXIGPnACLK | Async | 32 | 8, 8 | - |
| L2 cache | DDR controller | AXI | CPU_6x4x | DDR_3x | Async | 64 | 8, 8 | X |
| Central interconnect | DDR controller | AXI | CPU_2x | DDR_3x | Async | 64 | 8, 8 | - |
| Memory interconnect | DDR controller | AXI | DDR_2x | DDR_3x | Async | 64 | 8, 8 | - |
| Slave interconnect | GPV | ⁽³⁾ | CPU_2x | (multiple) | - | - | - | - |

Notes:

1. Each asynchronous path includes an asynchronous bridge for clock domain crossing.
2. Burst-length dependent (see [AXI_HP Interfaces](#)).
3. The path from the slave interconnect to GPV is an internal path within the entire interconnect structure. When accessing GPV, ensure that all clocks are on.

5.1.4 Clock Domains

The interconnect, masters, and slaves use the clocks shown in [Table 5-2](#):

Table 5-2: Clocks used by Interconnect, Masters, and Slaves

| CPU_6x4x: | CPUs, SCU, L2 Cache controller, On-Chip RAM |
|-----------|---|
| CPU_2x | Central interconnect, master interconnect, slave interconnect, OCM interconnect |
| CPU_1x | AHB masters, AHB slaves, APB slaves, DevC, DAP |
| DDR_3x | DDR Memory Controller |
| DDR_2x | Memory interconnect, FIFOs |

Table 5-2: Clocks used by Interconnect, Masters, and Slaves (Cont'd)

| CPU_6x4x: | CPUs, SCU, L2 Cache controller, On-Chip RAM |
|------------|---|
| SAXIACPCLK | AXI_ACP slave port |
| SAXIHP0CLK | AXI_HP0 slave port |
| SAXIHP1CLK | AXI_HP1 slave port |
| SAXIHP2CLK | AXI_HP2 slave port |
| SAXIHP3CLK | AXI_HP3 slave port |
| SAXIGP0CLK | AXI_GP0 slave port |
| SAXIGP1CLK | AXI_GP1 slave port |
| MAXIGP0CLK | AXI_GP0 master port |
| MAXIGP1CLK | AXI_GP1 master port |

Except for CPU_6X4X, CPU_2X, and CPU_1X, which are synchronous clocks with a ratio of 6:2:1 or 4:2:1, all clocks in Table 5-2 are asynchronous to one another, as shown in Figure 5-2.

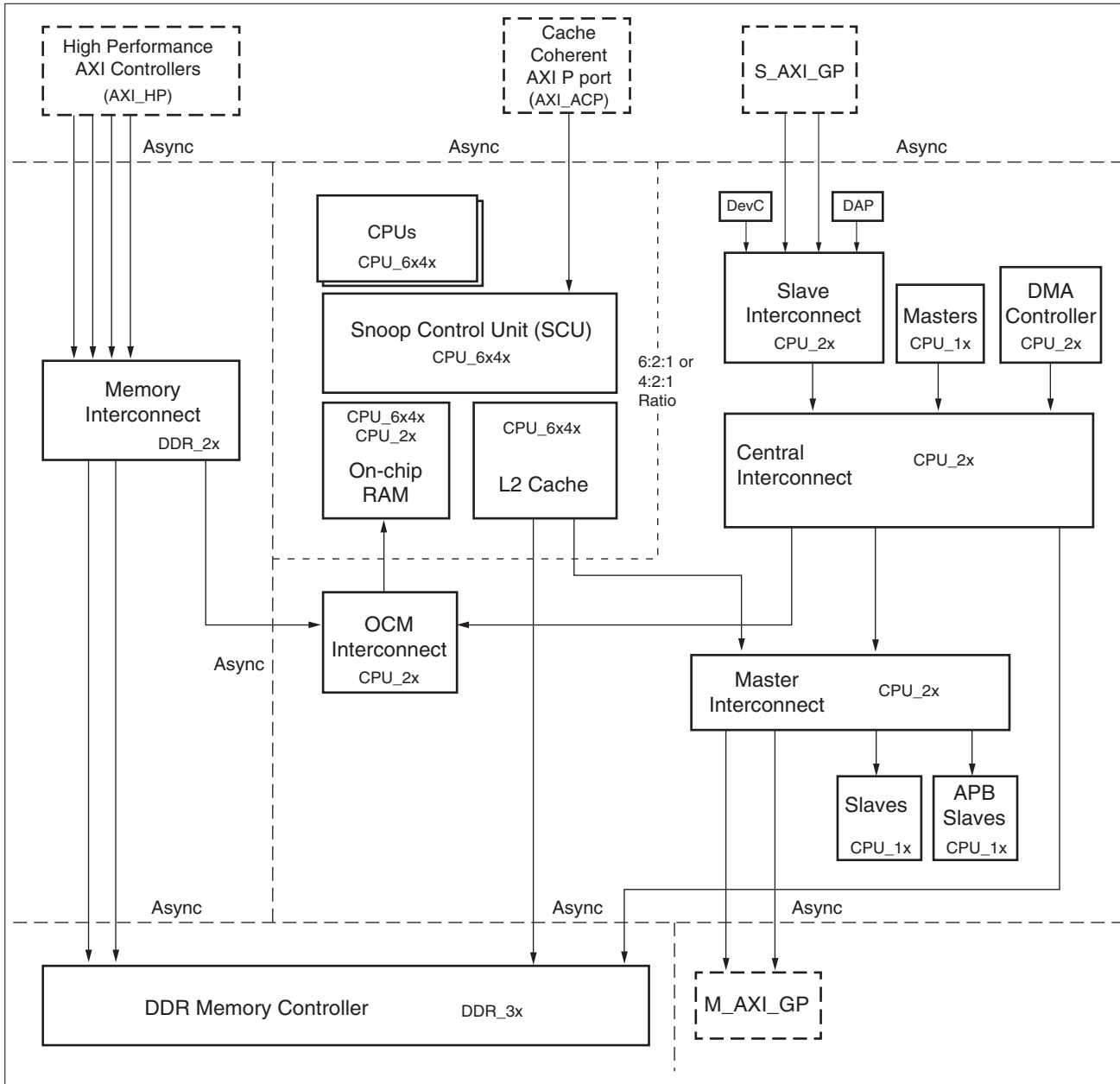

UG585_c5_02_120813

Figure 5-2: Interconnect Clock Domains

5.1.5 Connectivity

The interconnect is not a full cross-bar structure. Table 5-3 shows which master can access which slave.

Table 5-3: Master - Slave Access

| Master | Slave | On-chip RAM | DDR Port 0 | DDR Port 1 | DDR Port 2 | DDR Port 3 | M_AXI _GP | AHB Slaves | APB Slaves | GPV |
|------------------|-------|-------------|------------|------------|------------|------------|-----------|------------|------------|-----|
| CPU _s | | X | X | | | | X | X | X | X |
| AXI_ACP | | X | X | | | | X | X | X | X |
| AXI_HP{0,1} | | X | | | | X | | | | |
| AXI_HP{2,3} | | X | | | X | | | | | |
| S_AXI_GP{0,1} | | X | | X | | | X | X | X | |
| DMA Controller | | X | | X | | | X | X | X | |
| AHB Masters | | X | | X | | | X | X | X | |
| DevC, DAP | | X | | X | | | X | X | X | |

5.1.6 AXI ID

The interconnect uses 13-bit AXI IDs, consisting of (from MSB to LSB):

- Three bits that identify the interconnect (central, master, slave, etc.)
- Eight bits supplied by the master; width is determined by the largest AXI ID width among all masters
- Two bits that identify the slave interface of the identified interconnect

Table 5-4 lists all possible AXI ID values that a slave can observe.

Table 5-4: Slave Visible AXI ID Values

| Master | Master ID Width | AXI ID (as seen by the slaves) |
|-----------------|-----------------|--------------------------------|
| AXI_HP0 | 6 | 13'b00000xxxxxx00 |
| AXI_HP1 | 6 | 13'b00000xxxxxx01 |
| AXI_HP2 | 6 | 13'b00000xxxxxx10 |
| AXI_HP3 | 6 | 13'b00000xxxxxx11 |
| DMAC controller | 4 | 13'b0010000xxxx00 |
| AHB masters | 3 | 13'b00100000xxx01 |
| DevC | 0 | 13'b0100000000000 |

Table 5-4: Slave Visible AXI ID Values (Cont'd)

| Master | Master ID Width | AXI ID (as seen by the slaves) |
|----------------------------------|-----------------|--------------------------------|
| DAP | 0 | 13'b0100000000001 |
| S_AXI_GP0 | 6 | 13'b01000xxxxxx10 |
| S_AXI_GP1 | 6 | 13'b01000xxxxxx11 |
| CPUs, AXI_ACP through L2 M1 port | 8 | 13'b011xxxxxxx00 |
| CPUs, AXI_ACP through L2 M0 port | 8 | 13'b100xxxxxxx00 |

Notes:

1. x, which can be either 0 or 1, originates from the requesting master.

5.1.7 Read/Write Request Capability

The R/W Request Capability shown in Figure 5-1 and in Table 5-1 describes the maximum number of requests that the master of a datapath can issue. This does not mean the master can always issue the maximum number of requests under all circumstances or scenarios. There are conditions where other limiting factors can be active to reduce the number of requests.

One particular example is the extended write rule in the deadlock avoidance scheme, which ensures the network only issues a write transaction (on the AW channel) if all the outstanding write transactions have had the last write data beat transmitted (on the W channel). Under this rule, if the number of write data beats is large, preventing a second write request from being issued in a certain spot in the network, because the network must wait until the last beat of write data of the first write is transmitted, then only a single write request can be issued by a master.

5.1.8 Register Overview

Table 5-5 provides an overview of the GPV registers.

Table 5-5: GPV Register Overview

| Function | Name | Overview |
|--------------|--|---|
| TrustZone | security_gp0_axi security_gp1_axi | Control boot secure settings for the slave ports of the slave interconnect. |
| Advanced QoS | qos_cntl, max_ot, max_comb_ot, aw_p, aw_b, aw_r, ar_p, ar_b, ar_r | Control advanced QoS features, maximum number of outstanding transactions, AW and AR channel peak rates, burstiness, average rates. |

5.2 Quality of Service (QoS)

5.2.1 Basic Arbitration

Each interconnect (central, master, slave, memory) uses a two-level arbitration scheme to resolve contention. The first-level arbitration is based on the priority indicated by the AXI QoS signals from the master or programmable registers. The highest QoS value has the highest priority. The second-level arbitration is based on a least recently granted (LRG) scheme and is used when multiple requests are pending with the same QoS signal value. Information on OCM arbitration can be found in [Chapter 10, DDR Memory Controller](#).

5.2.2 Advanced QoS

In addition to the basic arbitration, the interconnect provides an advanced QoS control mechanism. This programmable mechanism influences interconnect arbitration for requests from these masters:

- CPUs and ACP requests to DDR (through L2 cache controller port M0)
- DMA controller requests to DDR and OCM (through the central interconnect)
- AMBA master requests to DDR and OCM (through the central interconnect)

In the PS, advanced QoS modules exist on the following paths:

- Path from L2 cache to DDR
- Path from DMA controller to the central interconnect
- Path from AHB masters to the central interconnect

The QoS module is based on Arm QoS-301, which is an extension to the NIC-301 network interconnect. They provide facilities to regulate transactions as follows:

- Maximum number of outstanding transactions
- Peak rates,
- Average rates
- Burstiness

For more information, refer to *CoreLink QoS-301 Network Interconnect Advanced Quality of Service Technical Reference Manual*.

The use of QoS arbitration for all slave interfaces should be performed with careful deliberation, as fixed priority arbitration leads to starvation issues if not used properly. By default, all ports have equal priority so starvation is not an issue.

Rationale

You are expected to create “well behaved” masters in the PL, which sufficiently throttle their rate of command issuance, or use the AXI_HP issuance capability settings. However, traffic from CPUs

(through L2 cache), the DMA controller, and the IOP masters can interfere with traffic from the PL. The QoS modules allow you to throttle these PS masters to ensure expected/consistent throughput and latency for the user design in the PL or specific PS masters. This is especially useful for video, which requires guaranteed maximum latency. By regulating the “irregular” masters such as CPUs, the DMA controller, and IOP masters, it is possible to guarantee maximum latency for PL-based video.

5.2.3 DDR Port Arbitration

The PS interconnect uses all four QoS signals except where it attaches to the DDR memory controller, which takes only the most significant QoS signal. A 3-input mux selects among this QoS signal, another signal from the SLCR.DDR_URGENT register, and a DDRARB signal directly from the PL to determine if a request is urgent. Refer to [Chapter 10, DDR Memory Controller](#) for more details.

5.3 AXI_HP Interfaces

The four AXI_HP interfaces provide PL bus masters with high bandwidth datapaths to the DDR and OCM memories. Each interface includes two FIFO buffers for read and write traffic. The PL to memory interconnect routes the high-speed AXI_HP ports to two DDR memory ports or the OCM. The AXI_HP interfaces are also referenced as AFI (AXI FIFO interface), to emphasize their buffering capabilities. The PL level shifters must be enabled through LVL_SHFTR_EN before PL logic communication can occur.

5.3.1 Features

The interfaces are designed to provide a high throughput datapath between PL masters and PS memories, including the DDR and on-chip RAM. The main features include:

- 32- or 64-bit data wide master interfaces (independently programmed per port)
- Efficient dynamic upsizing to 64-bits for aligned transfers in 32-bit interface mode, controllable through AxCACHE[1]
- Automatic expansion to 64-bits for unaligned 32-bit transfers in 32-bit interface mode
- Programmable release threshold of write commands
- Asynchronous clock frequency domain crossing for all AXI interfaces between the PL and PS
- Smoothing out of “long-latency” transfers using 1 KB (128 by 64 bit) data FIFOs for both reads and writes
- QoS signaling available from PL ports
- Command and data FIFO fill-level counts available to the PL
- Standard AXI 3.0 interfaces supported
- Programmable command issuance to the interconnect, separately for read and write commands
- Large slave interface read acceptance capability in the range of 14 to 70 commands (burst length dependent)

- Large slave interface write acceptance capability in the range of 8 to 32 commands (burst length dependent)

5.3.2 Block Diagram

Figure 5-3 shows the block diagram for the AXI_HP interfaces.

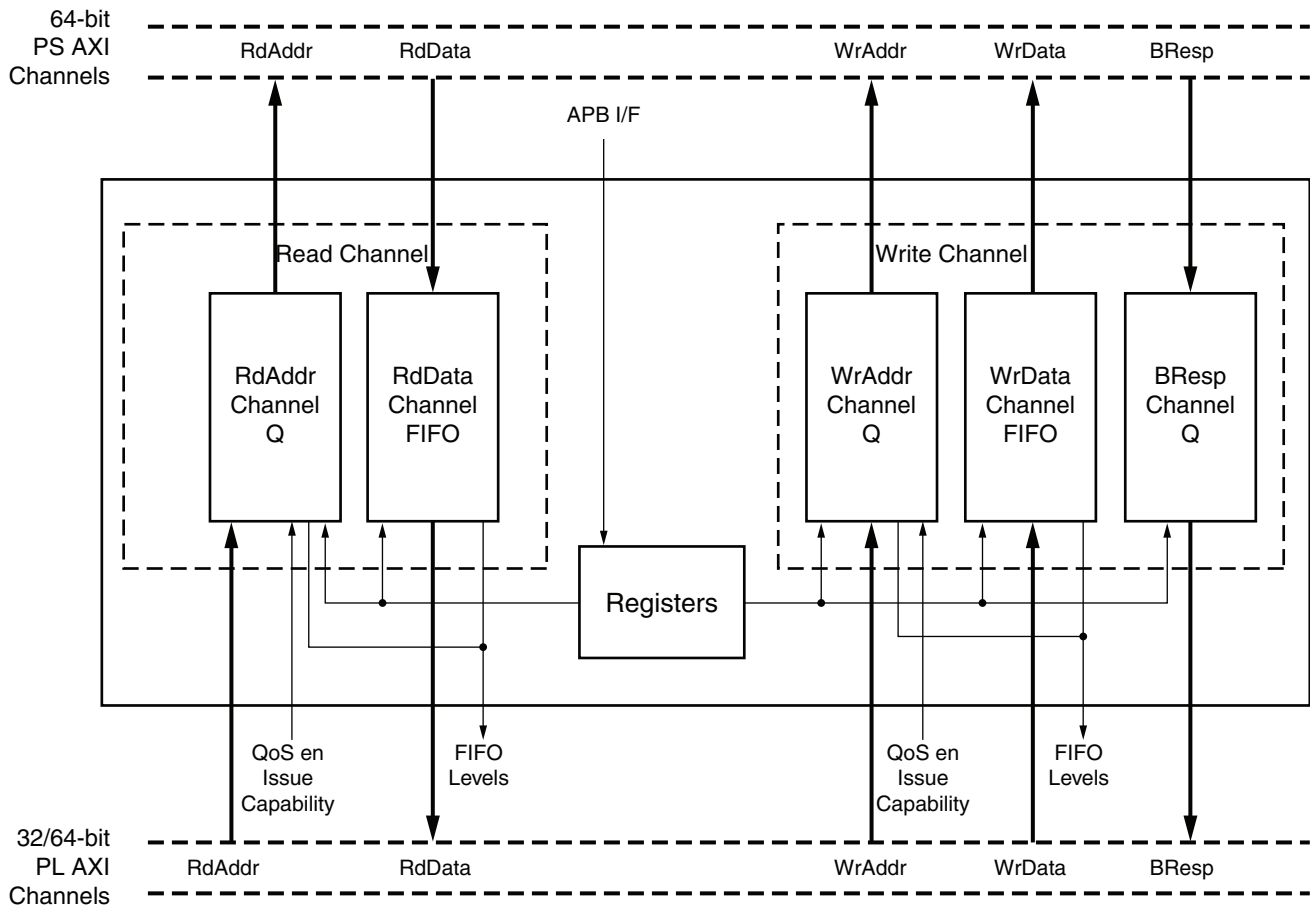

UG585_c5_03_121613

Figure 5-3: AXI_HP Block Diagram

5.3.3 Functional Description

There are two sets of AXI ports, one set connecting directly to the PL and the other connecting to the AXI interconnect matrix, allowing access to DDR and OCM memory (see [Figure 5-4](#)).

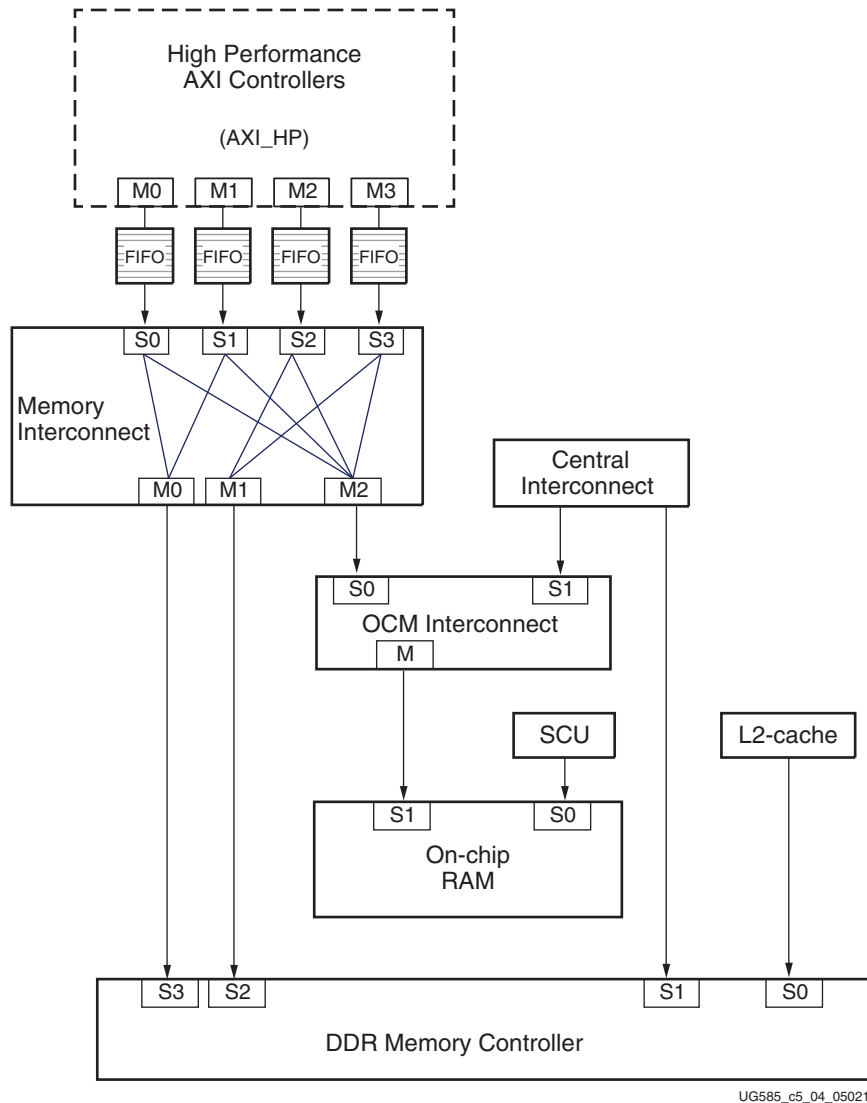

UG585_c5_04_050212

Figure 5-4: High Performance (AXI_HP) Connectivity

5.3.4 Performance

See [Chapter 22, Programmable Logic Design Guide](#) for more information.

5.3.5 Register Overview

A partial list of registers related to the high performance AXI port is listed in [Table 5-6](#)

Table 5-6: High Performance (AFI) AXI Register Overview

| Module | Register Name | Overview |
|--------|--|--|
| AXI_HP | AFI_RDCHAN_CTRL AFI_WRCHAN_CTRL | Select 64- or 32-bit interface width mode. Various bandwidth management control settings. |
| | AFI_RDCHAN_ISSUINGCAP AFI_WRCHAN_ISSUINGCAP | Maximum outstanding read/write commands |
| | AFI_RDQOS AFI_WRQOS | Read/write register-based quality of service (QoS) priority value |
| | AFI_RDDATAFIFO_LEVEL AFI_WRDATAFIFO_LEVEL | Read/write data FIFO register occupancy |
| OCM | OCM_CONTROL | Change arbitration priority of HP (and central interconnect) accesses at OCM with respect to SCU writes. |
| DDRC | axi_priority_rd_port2 axi_priority_wr_port2 | Various priority settings for arbitration at DDR controller for AXI_HP (AFI) ports 2 and 3 |
| | axi_priority_rd_port3 axi_priority_wr_port3 | Various priority settings for arbitration at DDR controller for AXI_HP (AFI) ports 0 and 1 |
| SLCR | LVL_SHFTR_EN | Level shifters. Must be enabled before using any of the PL AXI interfaces. |

5.3.6 Bandwidth Management Features

For applications requiring multiple programmable logic masters on multiple high performance AXI interface ports simultaneously, and in the presence of a medium or heavily loaded PS system, the management of the bandwidth per programmable logic port or “thread” becomes more difficult.

For example, if real-time type traffic is required on one thread, possibly mixed with non real-time traffic on other threads/ports, the standard AXI 3.0 bus protocol does not explicitly provide methods to manage priority.

The high performance AXI interface module does provide several functions to assist priority and queue management. The majority of management functions are provided to both the programmable logic design as PL signals and the PS as registers, as performance optimization is application dependent. This allows maximum flexibility, while simplifying the high performance AXI interface requirements.

The additional signals provided to the PL in addition to standard AXI3 signals are provided in [Table 5-7](#). The priority and occupancy management functions provided are discussed in the following sections.

Table 5-7: Additional per-port HP PL Signals

| Type | PS-PL Signal Name | I/O | Description |
|----------------------------------|---------------------------|-----|--|
| FIFO occupancy | SAXIHP{0-3}RCOUNT[7:0] | O | Fill level of the RdData channel FIFO |
| | SAXIHP{0-3}WCOUNT[7:0] | O | Fill level of the WrData channel FIFO |
| | SAXIHP{0-3}RACOUNT[2:0] | O | Fill level of the RdAddr channel FIFO |
| | SAXIHP{0-3}WACOUNT[5:0] | O | Fill level of the WrAddr channel FIFO |
| Quality of service | SAXIHP{0-3}AWQOS[3:0] | I | WrAddr channel QoS input. Qualified by SAXIHP{0-3}AWVALID |
| | SAXIHP{0-3}ARQOS[3:0] | I | RdAddr channel QoS input. Qualified by SAXIHP{0-3}ARVALID |
| Interconnect issuance throttling | SAXIHP{0-3}RDISSUECAP1EN | I | When asserted (1), indicates that the maximum outstanding read commands (issuing capability) should be derived from the "rdIssueCap1" register. |
| | SAXIHP{0-3}WRDISSUECAP1EN | I | When asserted (1), indicates that the maximum outstanding write commands (issuing capability) should be derived from the "wrIssueCap1" register. |

QoS Priority

The AXI QoS input signals can be used to assign an arbitration priority to the read and write commands.

Note that the PS interconnect allows either master control or programmable (register) control as a configuration option. For the AFI, it is desirable to have the ability for masters to dynamically change the QoS inputs. However, to provide flexibility the register field `axi_hp.AFI_RDCHAN_CTRL` [FabricQosEn] is provided. This allows a static QoS value to be programmed through the high performance AXI interface port, ignoring the PL AXI QoS inputs.

FIFO Occupancy

The level of the data and command FIFOs for both read and write are exported to the PL, allowing you to take advantage of the QoS feature supported by the top-level interconnect. Based on the relative levels of these FIFOs, a PL controller could dynamically change the priority of the individual read and write requests into the high performance AXI interface block(s). For example, if a particular PL master read data FIFO is getting too empty, the priority of the read requests could be increased.

The filling of this FIFO now takes priority over the other three FIFOs. When the FIFO reaches an acceptable fill-level, the priority typically is reduced again. The exact scheme used to control the relative priorities is flexible, as it must be performed in the programmable logic. Note that the "FIFO Level" should be used as a relative level, as opposed to an exact level, because clock domain crossing is involved.

Another possible application of the FIFO levels is using them to "look ahead" at the data fill level to determine if data can be read or written without having to use AXI RVALID/WREADY handshake signals. This could potentially simplify the AXI interface design logic, enabling higher speeds of operation.

Interconnect Issuance Throttling

To optimize the latency or throughput of other masters in the system such as the CPUs, it might be desirable to constrain the number of outstanding transactions that a high-performance port requests to the system interconnect. Issuing capability is the maximum number of outstanding commands that a HP can request at any one time.

Control of the read and write command issuing capability of the high performance AXI interface is available as a primary input from the logic. This option can be enabled by means of the `axi_hp.AFI_{RD, WR}CHAN_CTRL` [FabricOutCmdEn] register fields.

The logic signals, `SAXIHP{0-3}RDISSUECAP1_EN` and `SAXIHP{0-3}WRISSUECAP1_EN` allow you to change the issuing capability of the AFI block to the PS dynamically between two levels.

Write FIFO Store and Forward

The write channels can be configured to store and forward write commands or allow them to pass through with no storage. The following two registers control the mode of write, store, and forward:

- `axi_hp.AFI_WRCHAN_CTRL` [WrCmdReleaseMode]
- `axi_hp.AFI_WRCHAN_CTRL` [WrDataThreshold]

The mode register selects between a complete AXI burst store and forward, a partial AXI burst store and forward, or a pass through (no store at all). If absolute minimum latency for write commands is required, the pass-through mode could be selected. However, in cases where multiple masters are competing for the system slaves, better system performance can likely be achieved using at least the partial AXI burst store and forward mode. This is because once an AXI write is committed at each point throughout the PS, the entire burst must be processed before any other write data from other write commands can be processed.

For example, using pass-through mode, if one HP port with a slow clock rate issues a long burst, a second port with a faster clock rate might need to wait until the entire slower write data burst has been transferred, even if all of the write data on the fast clock is available. This is different from the case of reads, where read data interleaving is permitted.

32-bit Interface Considerations

Each physical high performance PL AXI interface is programmable to be either a 32-bit or 64-bit interface through the register field `axi_hp.AFI_{RD, WR}CHAN_CTRL` [32BitEn]. Note that the read and write channels have separate enables and can therefore be configured differently.

Upsizing and Expansion

In 32-bit mode, some form of translation between the 32-bit port and the 64-bit port is required. For write data, the 32-bit data (and write strobes) must be aligned correctly onto the appropriate lanes in the 64-bit domain. For read data, the appropriate lanes of the 64-bit data must be aligned onto the 32-bit data bus. This data alignment between different width interfaces are automatically dealt with by the high performance AXI interface module.

For the 32-bit mode, an “expansion” or “upsizing” must be performed to the 64-bit bus. These are defined as follows:

- Expansion. The AxSIZE[] and AxLEN[] signals remain unchanged on the 64-bit bus. The number of data beats in the 64-bit domain is therefore the same as the number of data beats in the 32-bit domain. This is the simplest option but also the most inefficient in terms of bandwidth utilization.
- Upsizing. This is an optimization that makes better use of the 64-bit bus available bandwidth. The AxSIZE[] signal can be changed to `64-BIT (expansion case it is `32-BIT or less) and the AxLEN[] field can potentially be adjusted to make use of the 64-bit bus. For a full width transfer, the number of data beats in the 64-bit domain is now, at best, *half* the number of data beats in the 32-bit domain. For example, a burst of 16x32-bit is upsized to a burst of 8x64-bit.

Note: Upsizing only occurs if the AxCACHE[1] bit is set; if it is not, expansion of the command occurs. This means that you can dynamically control, on a per-command basis, whether to expand or upsize.

Note: In 64-bit mode, there is no translation between the programmable logic transactions and the internal 64-bit PS transactions. Whatever appears at the PL port is passed as is to the PS port. In 64-bit mode, no upsizing or expansion is performed. This also applies to narrow transactions in the 64-bit mode.

32-bit Interface Limitations

The high performance AXI interface imposes the following constraints:

1. In 32-bit mode, only burst multiples of 2, incremental burst read commands, aligned to 64-bit boundaries are upsized. All other 32-bit commands are expanded. These include all narrow transactions (wrap as well as fixed burst types).
2. Whenever an expanded read command is accepted from the programmable logic by the AFI, this command is blocked until all outstanding high performance AXI interface read commands in the pipeline are flushed. The flushing occurs automatically under control of the AFI.

The implication is that for expanded commands, performance is very limited, as command pipelining is essentially disabled.

Note: All valid AXI command are still supported, just not optimized to take advantage of the 64-bit bus bandwidth.

In the case of write commands completing out-of-order, no performance penalty is incurred because the BRESP can be issued in any order directly back to the PL ports.

To be symmetric across read and write operations, the high performance AXI interface also only upsizes 64-bit aligned burst multiples of 2, incremental burst write commands, in 32-bit mode. However, in the case of writes, no “blocking” of expanded commands occurs. Write performance for expanded commands in 32-bit mode is therefore much higher than read performance.

5.3.7 Transaction Types

Table 5-8 summarizes the command types issued to the high performance AXI interface from the PL, and the command modifications that occur.

Table 5-8: High Performance AXI Interface Command Types

| No. | Mode | Command Type | Translation | Comments |
|-----|--------|--|---------------------|---|
| 1 | 64-bit | 64-bit reads all burst types | None | Best optimization possible |
| 2 | 64-bit | Narrow read | None | Because no upsizing is performed, the narrower the width, the more inefficient the transaction. |
| 3 | 64-bit | 64-bit write all burst types | None | Best optimization possible |
| 4 | 64-bit | Narrow write | None | Because no upsizing is performed, the narrower the width, the more inefficient the transaction. |
| 5 | 32-bit | 32-bit INCR read aligned to 64-bit even burst multiples | Upsized to 64-bits | Best 32-bit mode optimization possible |
| 6 | 32-bit | All other 32-bit read commands | Expanded to 64-bits | Each read command is blocked until all previous read commands are completed. Extremely inefficient. |
| 7 | 32-bit | 32-bit INCR write aligned to 64-bit even burst multiples | Upsized to 64-bits | Best 32-bit mode optimization possible |
| 8 | 32-bit | All other 32-bit write commands | Expanded to 64-bits | Relatively inefficient because no upsizing is performed. No blocking occurs for writes. |

5.3.8 Command Interleaving and Re-Ordering

When multi-threaded commands are used in AXI, there is the potential for commands being processed out-of-order as well as interleaving of data beats.

The DDR controller guarantees that all read commands are completed continuously, that is, it does not interleave read data onto its external AXI ports. It does however take advantage of re-ordering of read and write commands, to perform internal optimizations. It is therefore expected that read and write commands issued to the DDR controller are sometimes completed in a different order from which they were issued.

Read data interleaving is not supported by either the DDR or the OCM. However, the interconnect might introduce read data interleaving into the system when a single PL port issues multi-threaded read commands to both the DDR and OCM memories.

From the high performance AXI interface perspective:

- Both read and write commands can be re-ordered.
- Read data interleaving might occur.

5.3.9 Performance Optimization Summary

This section summarizes the most important considerations when using the high performance AXI interface module from a software or user perspective.

- For general purpose AXI transfers, use the general purpose PS AXI ports and not these ports. These ports are optimized for high throughput applications, but have various limitations.
- [Table 5-8](#) summarizes the different command types issued to the high performance AXI interface module from the PL and the way in which they are dealt with.
- When using 32-bit mode, it is strongly recommended not to use commands of the type shown in line 6 of [Table 5-8](#), as this impacts performance significantly.
- The QoS PL inputs can be controlled from physical programmable logic signals or statically configured in APB registers. The signals allow QoS values to be changed on a per-command basis. The register control is static for all commands.
- The AxCACHE[1] must be set for upsizing to occur. If this bit is not set, expansion always occurs.
- If the PL design demands a continuous read data flow after the first data beat has been read, the design must first allow the read data FIFO to fill with the complete transaction data before popping the first data beat out. The FIFO level is exported to the PL for this purpose. This behavior might be useful if the PL master is not able to be throttled by RVALID after the first data exits the read FIFO.
- Wait states can be inserted if write commands are not asserted at least one cycle ahead of the corresponding first write data beat in 32-bit AXI channel slave interface mode.
- The PL masters should be able to handle read data interleaving. If it is desired that they not deal with this issue, they should not issue multi-threaded read commands to both the OCM and DDR from the same port by using the same ARID value for all outstanding read requests.
- The relationship of write FIFO occupancy to the write data ready to accept signal (WREADY) varies as follows:
 - In 64-bit AXI mode, FIFO not full (SAXIHP0WCOUNT << 128) always implies WREADY=1.
 - In 32-bit AXI mode, there is a dependency between the write address (AWVALID) and the write data (WVALID). If the write address is presented at least one cycle before the first beat of any given write data burst, then the FIFO not full (SAXIHP0WCOUNT << 128) implies WREADY=1. If not, then WREADY is deasserted until the write address is produced. The reason for this back pressure is that in 32-bit mode, expansion/upsizing is performed on the data into the write data FIFO.
- Write response (BVALID) latency is dependent on many factors, such as DDR latency, DDR transaction reordering, and other conflicting traffic (including higher-priority transactions). Write commands and data are sent the entire path to the slave (DDR or OCM) and the response is issued by the slave to return to the high performance AXI interface. Transactions issued after reception of the write response is guaranteed to be committed later at the slave than the responded write transaction. Note that by default, all PS peripherals are set to secure Trustzone mode. This means that any non-secure accesses indicated with AxPROT[1]=1 will received a DECERR response.

5.4 AXI_ACP Interface

The accelerator coherency port provides low-latency access to programmable logic masters, with optional coherency with L1 and L2 cache. From a system perspective, the ACP interface has similar connectivity as the APU CPUs. Due to this close connectivity, the ACP directly competes with them for resource access outside of the APU block. Figure 5-5 gives an overview of the ACP connectivity.



IMPORTANT: The PL level shifters must be enabled by `LVL_SHFTR_EN` before PL logic communication can occur.

Note: By default, all PS peripherals are set to secure Trustzone mode. This means that any non-secure accesses indicated with `AxPROT[1]=1` will receive a DECERR response.

For more information about the ACP interface, including its limitations, see Chapter 3, Application Processing Unit.

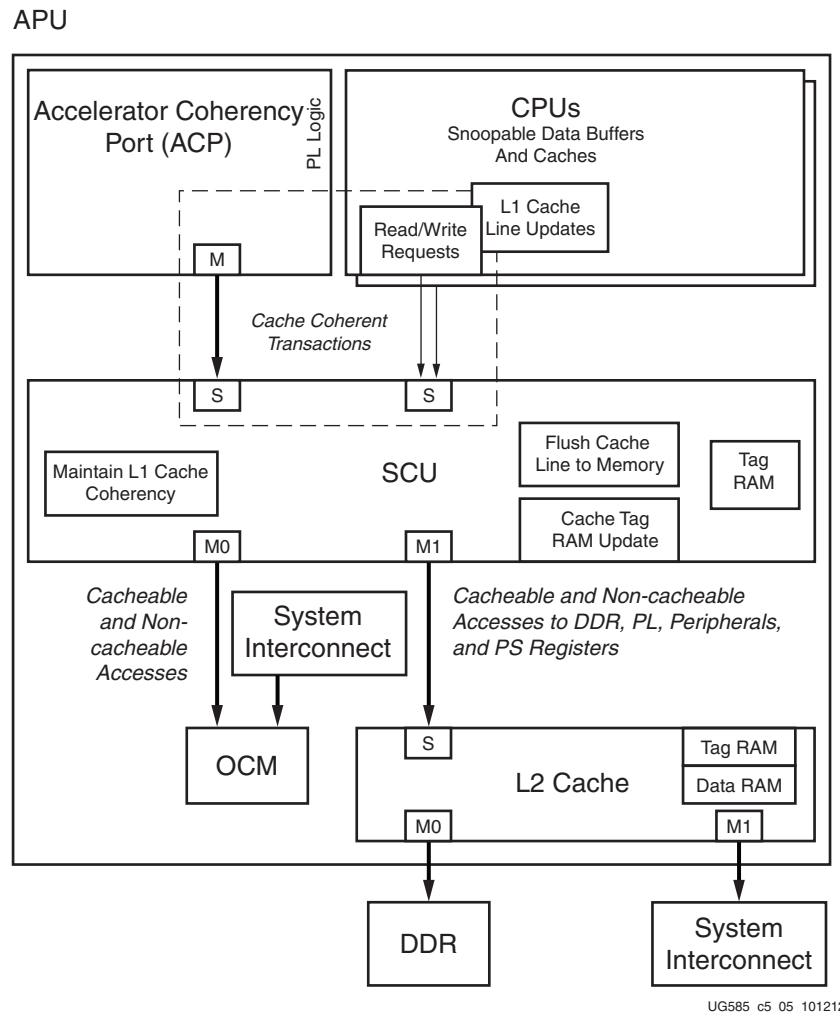

Figure 5-5: ACP Connectivity Diagram

5.5 AXI_GP Interfaces

5.5.1 Features

AXI_GP features include:

- Standard AXI protocol
- Data bus width: 32
- Master port ID width: 12
- Master port issuing capability: 8 reads, 8 writes
- Slave port ID width: 6
- Slave port acceptance capability: 8 reads, 8 writes

5.5.2 Performance

These interfaces are connected directly to the ports of the master interconnect and the slave interconnect, without any additional FIFO buffering, unlike the AXI_HP interfaces which has elaborate FIFO buffering to increase performance and throughput. Therefore, the performance is constrained by the ports of the master interconnect and the slave interconnect. These interfaces are for general-purpose use only and are not intended to achieve high performance.



IMPORTANT: *The PL level shifters must be enabled by LVL_SHFTR_EN before PL logic communication can occur.*

Note: By default, all PS peripherals are set to secure Trustzone mode. This means that any non-secure accesses indicated with AxPROT[1]=1 will received a DECERR response.

PL bus master controllers attached to AXI general purpose ports (S_AXI_GP[1:0]) can access PS I/O Peripherals and cannot access CPU Private Bus Registers.

5.6 PS-PL AXI Interface Signals

5.6.1 AXI Signals

AXI signals are identified in [Table 5-9](#). The PL level shifters must be enabled by the LVL_SHFTR_EN register before PL logic communication can occur, refer to section [2.4 PS-PL Voltage Level Shifter Enables](#).

Table 5-9: AXI Signals Summary

| AXI Channel | AXI PS Masters | | AXI PS Slaves | |
|---------------------|-------------------------|-----|---|-----|
| | M_AXI_GP{0,1} | I/O | S_AXI_GP{0,1} S_AXI_HP{0:3} S_AXI_ACP | I/O |
| Clock, Reset | | | | |
| | MAXIGP{0,1}ACLK | I | SAXIGP{0,1}ACLK SAXIHP{0:3}ACLK SAXIACPACLK | I |
| | MAXIGP{0,1}ARESETN | O | SAXIGP{0,1}ARESETN SAXIHP{0:3}ARESETN SAXIACPARESETN | O |
| Read Address | | | | |
| | MAXIGP{0,1}ARADDR[31:0] | O | SAXIGP{0,1}ARADDR[31:0] SAXIHP{0:3}ARADDR[31:0] SAXIACPARADDR[31:0] | I |
| | MAXIGP{0,1}ARVALID | O | SAXIGP{0,1}ARVALID SAXIHP{0:3}ARVALID SAXIACPARVALID | I |
| | MAXIGP{0,1}ARREADY | I | SAXIGP{0,1}ARREADY SAXIHP{0:3}ARREADY SAXIACPARREADY | O |
| | MAXIGP{0,1}ARID[11:0] | O | SAXIGP{0,1}ARID[5:0] SAXIHP{0:3}ARID[5:0] SAXIACPARID[2:0] | I |
| | MAXIGP{0,1}ARLOCK[1:0] | O | SAXIGP{0,1}ARLOCK[1:0] SAXIHP{0:3}ARLOCK[1:0] SAXIACPARLOCK[1:0] | I |
| | MAXIGP{0,1}ARCACHE[3:0] | O | SAXIGP{0,1}ARCACHE[3:0] SAXIHP{0:3}ARCACHE[3:0] SAXIACPARCACHE[3:0] | I |
| | MAXIGP{0,1}ARPROT[2:0] | O | SAXIGP{0,1}ARPROT[2:0] SAXIHP{0:3}ARPROT[2:0] SAXIACPARPROT[2:0] | I |
| | MAXIGP{0,1}ARLEN[3:0] | O | SAXIGP{0,1}ARLEN[3:0] SAXIHP{0:3}ARLEN[3:0] SAXIACPARLEN[3:0] | I |
| | MAXIGP{0,1}ARSIZE[1:0] | O | SAXIGP{0,1}ARSIZE[1:0] SAXIHP{0:3}ARSIZE[2:0] SAXIACPARSIZE[2:0] | I |
| | MAXIGP{0,1}ARBURST[1:0] | O | SAXIGP{0,1}ARBURST[1:0] SAXIHP{0:3}ARBURST[1:0] SAXIACPARBURST[1:0] | I |
| | MAXIGP{0,1}ARQOS[3:0] | O | SAXIGP{0,1}ARQOS[3:0] SAXIHP{0:3}ARQOS[3:0] SAXIACPARQOS[3:0] | I |

Table 5-9: AXI Signals Summary (Cont'd)

| AXI Channel | AXI PS Masters | | AXI PS Slaves | |
|----------------------|-------------------------|-----|---|-----|
| | M_AXI_GP{0,1} | I/O | S_AXI_GP{0,1} S_AXI_HP{0:3} S_AXI_ACP | I/O |
| | ~ | | ~ ~ SAXIACPARUSER[4:0] | I |
| Read Data | | | | |
| | MAXIGP{0,1}RDATA[31:0] | I | SAXIGP{0,1}RDATA[31:0] SAXIHP{0:3}RDATA[63:0] SAXIACPRDATA[63:0] | O |
| | MAXIGP{0,1}RVALID | I | SAXIGP{0,1}RVALID SAXIHP{0:3}RVALID SAXIACPRVALID | O |
| | MAXIGP{0,1}RREADY | O | SAXIGP{0,1}RREADY SAXIHP{0:3}RREADY SAXIACPRREADY | I |
| | MAXIGP{0,1}RID[11:0] | I | SAXIGP{0,1}RID[5:0] SAXIHP{0:3}RID[5:0] SAXIACPRID[2:0] | O |
| | MAXIGP{0,1}RLAST | I | SAXIGP{0,1}RLAST SAXIHP{0:3}RLAST SAXIACPRLAST | O |
| | MAXIGP{0,1}RRESP[1:0] | I | SAXIGP{0,1}RRESP[2:0] SAXIHP{0:3}RRESP[2:0] SAXIACPRRESP[2:0] | O |
| | ~ | | ~ SAXIHP{0:3}RCOUNT[7:0] ~ | O |
| | ~ | | ~ SAXIHP{0:3}RACOUNT[2:0] ~ | O |
| | ~ | | ~ SAXIHP{0:3}RDISUECAP1EN ~ | I |
| Write Address | | | | |
| | MAXIGP{0,1}AWADDR[31:0] | O | SAXIGP{0,1}AWADDR[31:0] SAXIHP{0:3}AWADDR[31:0] SAXIACPAWADDR[31:0] | I |
| | MAXIGP{0,1}AWVALID | O | SAXIGP{0,1}AWVALID SAXIHP{0:3}AWVALID SAXIACPAWVALID | I |

Table 5-9: AXI Signals Summary (Cont'd)

| AXI Channel | AXI PS Masters | | AXI PS Slaves | |
|-------------------|-------------------------|-----|---|-----|
| | M_AXI_GP{0,1} | I/O | S_AXI_GP{0,1} S_AXI_HP{0:3} S_AXI_ACP | I/O |
| | MAXIGP{0,1}AWREADY | I | SAXIGP{0,1}AWREADY SAXIHP{0:3}AWREADY SAXIACPAWREADY | O |
| | MAXIGP{0,1}AWID[11:0] | O | SAXIGP{0,1}AWID[5:0] SAXIHP{0:3}AWID[5:0] SAXIACPAWID[2:0] | I |
| | MAXIGP{0,1}AWLOCK[1:0] | O | SAXIGP{0,1}AWLOCK[1:0] SAXIHP{0:3}AWLOCK[1:0] SAXIACPAWLOCK[1:0] | I |
| | MAXIGP{0,1}AWCACHE[3:0] | O | SAXIGP{0,1}AWCACHE[3:0] SAXIHP{0:3}AWCACHE[3:0] SAXIACPAWCACHE[3:0] | I |
| | MAXIGP{0,1}AWPROT[2:0] | O | SAXIGP{0,1}AWPROT[2:0] SAXIHP{0:3}AWPROT[2:0] SAXIACPAWPROT[2:0] | I |
| | MAXIGP{0,1}AWLEN[3:0] | O | SAXIGP{0,1}AWLEN[3:0] SAXIHP{0:3}AWLEN[3:0] SAXIACPAWLEN[3:0] | I |
| | MAXIGP{0,1}AWSIZE[1:0] | O | SAXIGP{0,1}AWSIZE[1:0] SAXIHP{0:3}AWSIZE[2:0] SAXIACPAWSIZE[2:0] | I |
| | MAXIGP{0,1}AWBURST[1:0] | O | SAXIGP{0,1}AWBURST[1:0] SAXIHP{0:3}AWBURST[1:0] SAXIACPAWBURST[1:0] | I |
| | MAXIGP{0,1}AWQOS[3:0] | O | SAXIGP{0,1}AWQOS[3:0] SAXIHP{0:3}AWQOS[3:0] SAXIACPAWQOS[3:0] | I |
| | ~ | | ~ ~ SAXIACPAWUSER[4:0] | I |
| Write Data | | | | |
| | MAXIGP{0,1}WDATA[31:0] | O | SAXIGP{0,1}WDATA[31:0] SAXIHP{0:3}WDATA[63:0] SAXIACPWDATA[63:0] | I |
| | MAXIGP{0,1}WVALID | O | SAXIGP{0,1}WVALID SAXIHP{0:3}WVALID SAXIACPWVALID | I |
| | MAXIGP{0,1}WREADY | I | SAXIGP{0,1}WREADY SAXIHP{0:3}WREADY SAXIACPWREADY | O |

Table 5-9: AXI Signals Summary (Cont'd)

| AXI Channel | AXI PS Masters | | AXI PS Slaves | |
|-----------------------|-----------------------|-----|---|-----|
| | M_AXI_GP{0,1} | I/O | S_AXI_GP{0,1} S_AXI_HP{0:3} S_AXI_ACP | I/O |
| | MAXIGP{0,1}WID[11:0] | O | SAXIGP{0,1}WID[5:0] SAXIHP{0:3}WID[5:0] SAXIACPWID[2:0] | I |
| | MAXIGP{0,1}WLAST | O | SAXIGP{0,1}WLAST SAXIHP{0:3}WLAST SAXIACPWLAST | I |
| | MAXIGP{0,1}WSTRB[3:0] | O | SAXIGP{0,1}WSTRB[3:0] SAXIHP{0:3}WSTRB[7:0] SAXIACPWSTRB[7:0] | I |
| | ~ | | ~ SAXIHP{0:3}WCOUNT[7:0] ~ | O |
| | ~ | | ~ SAXIHP{0:3}WACOUNT[5:0] ~ | O |
| | ~ | | ~ SAXIHP{0:3}WRISSUECAP1EN ~ | I |
| Write Response | | | | |
| | MAXIGP{0,1}BVALID | I | SAXIGP{0,1}BVALID SAXIHP{0:3}BVALID SAXIACPBVALID | O |
| | MAXIGP{0,1}BREADY | O | SAXIGP{0,1}BREADY SAXIHP{0:3}BREADY SAXIACPBREADY | I |
| | MAXIGP{0,1}BID[11:0] | I | SAXIGP{0,1}BID[5:0] SAXIHP{0:3}BID[5:0] SAXIACPBID[2:0] | O |
| | MAXIGP{0,1}BRESP[1:0] | I | SAXIGP{0,1}BRESP[1:0] SAXIHP{0:3}BRESP[1:0] SAXIACPBRESP[1:0] | O |

5.6.2 AXI Clocks and Resets

Each interface has a single clock for all five channels that make up an interface. This clock is provided by the PL.

All clocks must be active and all resets must be inactive on all PS-PL AXI interfaces for the GPV to function properly. The entire PS might hang if this condition is not satisfied and a GPV access is

attempted. Therefore, no GPV access should be attempted if not all of the clocks for the PS-PL AXI interfaces are connected and operating.

5.7 Loopback

Sometimes it can be advantageous to provide a loopback path from the PS to PL and back. A loopback path means that there will be an AXI connection between a PS master and PS slave through the PL, so that designs can manipulate AXI transaction address and/or data in the PL before the data reaches the intended target in the PS. Such a loopback path typically includes a combinatorial shim that translates the destination address from an address in the PL to an address in the PS.

It is not considered a loopback path if the AXI transaction from the PS is terminated in the PL, a separate AXI transaction is created from the PL to the PS, *and* there is no interlocking dependency between the two transactions.

In the SoC, the only allowed loopback path is from the GM ports to the HP ports within a set of constraints. Note that HP0 and HP1 share an internal switch, and HP2 and HP3 shares an internal switch. When there is a loopback path from the GM port to an HP port, there can be no other masters than the loopback on the HP port being used, as well as the other HP port sharing its internal switch. For an example, if there is a loopback path from GM1 port to HP1 port, then there can be no other masters on both HP0 and HP1 ports. Similarly, if there is a loopback path from GM0 port to HP2 port, then there can be no other masters on both HP2 and HP3 ports. See [Figure 5-6](#).

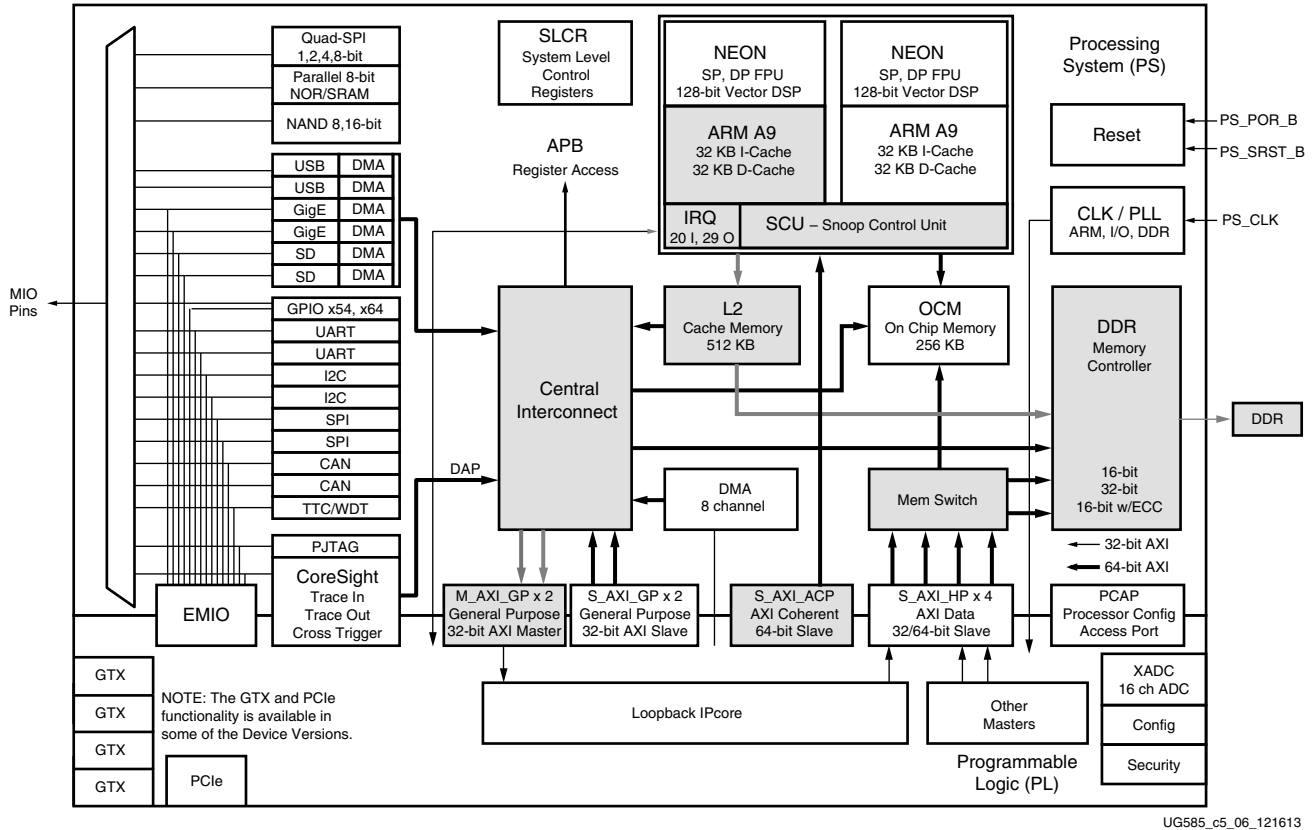

Figure 5-6: Loopback Path

5.8 Exclusive AXI Accesses

This section provides a summary of AXI exclusive accesses support and details its architectural limitations. Exclusive AXI accesses are most commonly generated by software in exclusive load and store instructions to implement semaphore structures.

The two Cortex-A9 cores and PL masters from the S_ACP, S_GP and S_HP ports can perform exclusive access. To succeed, exclusive accesses must also terminate to a slave that contains an exclusive monitor. However, the only exclusive monitors in the PS are in L1 cache, and each of the four PS DDRC ports (the OCM RAM does not have an exclusive monitor and so cannot accept exclusive accesses). A user-created L3 exclusive monitor can also be potentially created in the PL.

5.8.1 CPU/L2

There are exclusive monitors in APU L1 cache, but not in the L2 level cache. This means the exclusive access address must either terminate in L1 cache or L3 memory, but not in L2.

To use the L1 exclusive monitor, the addressed MMU region must be set to be inner cacheable and inner cache write-back with write-allocate. This allows an address targeted by a particular exclusive access to always be allocated to L1 cache.

To use the L3 exclusive monitor, the access must not terminate at the APU L2 cache. From the Arm CPU perspective, this means the address must be shareable, normal and non-cacheable. Also, the L2 cache controller shared override option (bit 22 in the L2 auxiliary control register) must be set in the auxiliary control register. By default in the APU L2 cache controller, any non-cacheable shared reads are treated as cacheable non-allocatable, while non-cacheable shared writes are treated as cacheable write-through/no write-allocate. The L2 cache controller shared override option in the PL310 auxiliary control register overrides this behavior and prevents allocation into L2 cache.

5.8.2 ACP

The PL ACP port does not support exclusive access to coherent memory. Therefore, if the ACP needs to perform exclusive accesses with the CPUs, the access must go to L3: DDR or PL.

5.8.3 DDRC

The following are the supported features for exclusive accesses to the PS DDR controller:

- The AXI port supports concurrent monitoring of two exclusive addresses (with different IDs).
- Burst type INCR/WRAP, length='h0 - 'hF, is supported.
- The slave supports OKAY and EXOKAY responses for exclusive accesses.
 - According to the AXI specification, the slave sends out an EXOKAY response for successful exclusive access transactions. For DDRC, this includes reads (up to two active) and writes that match a preceding exclusive read transaction, if the monitored location(s) is still valid.
 - If a monitored location is overwritten by another exclusive or non-exclusive write transaction through any slave port before its corresponding exclusive write, the slave returns an OKAY response for the exclusive write and will not update the corresponding memory locations.

The DDRC exclusive monitor uses AXI bus ID to determine which master is doing the exclusive load and store. While it is possible for a master to generate different IDs, a particular ID will always originate from the same master. The master should also make sure to use the same ID for their LDREX and STREX pair. Cortex-A9 processor will generate the same ID for its LDREX/STREX pair.

There are a some limitations:

1. While only two address locations (ranges) can be monitored concurrently by the DDRC, either of these locations can be updated by another exclusive read transaction while the current transactions have not been completed by their corresponding exclusive writes. In this case, the exclusive write for an earlier monitored address location will receive an OKAY response. The

exclusive monitor picks the slot to be used using round-robin mechanism. An example exclusive access sequence is shown in [Table 5-10](#), assuming one AXI ID per master:

Table 5-10: Example DDR Port Behavior

| Masters action | DDR Port behavior |
|--|--|
| Master 1 issues exclusive load to address A | Exclusive monitor 1 now has address A and master 1 recorded |
| Master 2 issues exclusive load to address B | Exclusive monitor 2 now has address B and master 2 recorded |
| Master 3 issues exclusive load to address C | Exclusive monitor 1 now has address C and master 3 recorded |
| Master 1 issues exclusive store to address A | DDRC returns with OKAY, indicating exclusive access had failed |
| Master 2 issues exclusive store to address B | DDRC returns with EXOKAY, indicating exclusive access successful |
| Master 3 issues exclusive store to address C | DDRC returns with EXOKAY, indicating exclusive access successful |

- Exclusive access between different AXI ports is not supported because the monitors do not share information with each other, thus the DDRC does not support exclusive access across different ports. This means only masters that will access the same DDR port can do exclusive access to a memory through DDR. Example master topologies able to perform exclusive access together are shown in [Table 5-11](#).

Table 5-11: Example Master Topologies

| Master Topology | Can Perform Exclusives Accesses Together to DDRC? |
|-----------------------------------|---|
| A9 core 0, A9 Core 1 | Yes |
| A9 core 0, ACP | Yes |
| PL master on GP0/1 with Cortex-A9 | No, GP0/1 ports and Cortex-A9 CPUs use different AXI DDRC AXI ports. |
| Master on HP0 with master on HP1 | Yes, (HP0 and HP1) and (HP2 and HP3) each share a common DDRC AXI port. |
| Master on HP1 with master on HP2 | No, HP1 and HP2 use different DDRC ports. |
| Master on GP0 with master HP0 | No, GP0/1 ports and HP0-3 ports use different DDRC ports. |
| Master on GP0 with master on GP1 | Yes, GP0/1 ports share a common DDRC AXI port. |

5.8.4 System Summary

Exclusive AXI accesses are summarized in [Table 5-12](#).

Table 5-12: Exclusive AXI Accesses Summary

| Exclusive Operation | Exclusive Accesses Supported | Notes |
|--|------------------------------|--|
| Two A9 CPUs to L1 cache | Yes | Normal, inner-cacheable, write-back with write-allocate memory regions only |
| ACP doing exclusive access to L1 | No | ACP does not support exclusive access to coherent memory. |
| CPU0 and CPU1 to location in L2 | No | L2 does not have exclusive monitors. |
| Two A9 CPU and ACP do exclusive access to DDR | Yes | DDR only support two addresses per port for exclusive access. If there are more than two masters, more than two addresses might be involved, and it might cause live-lock. Extra care should be taken to not get in a live-lock situation. |
| ACP and one of the CPUs do exclusive access to DDR | Yes | Only two masters are allowed. |
| Exclusive access from two A9 CPUs to DDR | Yes | When L1 and L2 cache is disabled, or when memory is marked as shared, normal, non-cacheable and the L2 shared override bit is set. |
| Masters on GP and HP ports doing exclusive access to DDR: <ul style="list-style-type: none"> • GP0 and GP1 can do exclusive access with each other only • HP0 and HP1 can do exclusive access with each other only • HP2 and HP3 can do exclusive access with each other only | Yes | DDRC cannot synchronize exclusive accesses across separate DDRC AXI ports. If more than 2 PL masters or AXI IDs are used per port of DDR, additional software is needed to prevent live-lock. |

Boot and Configuration

6.1 Introduction

Immediately after the PS_POR_B reset pin deasserts, the hardware samples the boot strap pins and optionally enables the PS clock PLLs. Then, the PS begins executing the BootROM code in the on-chip ROM to boot the system. The POR resets the entire device with no previous state saved. The non-POR type resets also cause the BootROM to execute, but without the hardware sampling the strap pins. After a non-POR reset, some registers values are preserved and the device is aware of its previous security mode. Non-POR resets include the PS_SRST_B pin and several internal reset sources.

The BootROM is the first software to run in the APU. The BootROM executes on CPU 0 and CPU 1 executes the wait-for-event (WFE) instruction. The main tasks of the BootROM are to configure the system, copy the Boot Image FSBL/User code from the boot device to the OCM, and then branch the code execution to the OCM. Optionally, the FSBL/User code can be executed directly from a Quad-SPI or NOR device in a non-secure environment.

The PS Master boot device holds one or more boot images. A boot image is made up of the BootROM Header (also referred to as the Boot Image Header) and the first stage boot loader (FSBL). The boot device can also hold a bitstream to configure the PL and an embedded operating system, but these are not accessed by the BootROM code. The flash memory device for boot can be Quad-SPI, NAND, NOR, or SD card.

The BootROM execution flow is affected by the pin strap settings, the BootROM Header, and what the BootROM code discovers about the system. The BootROM can execute in a secure environment with encrypted FSBL/User code, or a non-secure environment. After the BootROM executes, the FSBL/User code takes responsibility of the system as described in [UG821, Zynq-7000 SoC Software Developers Guide](#).

For development, the system can be booted in JTAG mode. Or, JTAG can be enabled after a non-secure flash device boot. JTAG always implies a non-secure environment, but it allows for access to the Arm debug access port (DAP) controller in the CPU complex (APU) and the Xilinx test access port (TAP) controller in the PL.

PS Master Boot Mode

In master boot mode, the system boots from a flash memory device. Here, the BootROM configures the PS to access the boot device, reads the BootROM header, validates the header, and then usually copies the FSBL/User code to the OCM memory. Master mode can be a secure or non-secure environment.

In secure mode, the boot image is always written to OCM memory by the CPU. From there, it is sent (using DMA) in and out of the AES/HMAC units for decryption and authentication. The decrypted boot image is written back to OCM memory and executed after the BootROM is finished. Security hardware is described in this chapter and in [Chapter 32, Device Secure Boot](#).

In non-secure mode, the BootROM header can instruct the PS to execute the boot image directly from a Quad-SPI or NOR boot device that supports the execute-in-place option. In other cases, the FSBL/User code is copied to the OCM memory for execution.

If the BootROM header in the flash device is invalid, the BootROM code searches for another header. The header search continues until a valid header is found or the entire range has been searched. The BootROM header search is supported for Quad-SPI, NAND, and NOR boot modes. For SD card boot mode, only one header is read.

JTAG Slave Boot

In JTAG boot mode, the BootROM code does minimal system configuration and enables a JTAG interface. Then, the system goes into an idle state waiting for the DAP controller to restart CPU 0. The cascade JTAG boot mode loops the DAP and TAP controllers, and is the most common JTAG boot mode. The independent JTAG boot mode connects the TAP controller to the PL JTAG pins and gives time for the user to configure the PL using the TAP controller to connect the DAP controller to the EMIO JTAG interface. The paths are shown in [Figure 6-7, page 191](#).

In non-secure master boot mode, the JTAG interface is enabled for debug when the PL is powered-up. The JTAG interface can be used to access the TAP and DAP controllers.

Boot and Configuration Subsections

Boot and Configuration is divided into the following sections:

- [Figure 6-1](#)
 - Overview of bring-up and configuration
- [Device Start-up](#)
 - Power-up, resets, clocks, Boot mode pins
- [BootROM Code](#)
 - Execution flow, BootROM header
 - Boot modes, image search, multiboot
 - Error codes, system state post-BootROM
- [Device Boot and PL Configuration](#)
 - PL initialization, configuration, and enable
 - PS/PL bring-up examples
 - PCAP bridge, JTAG (cascade/independent)
- [Reference Section](#)
 - PL bring-up time factors, register overview, and device IDs

Device Boot Flowchart

The POR reset causes the hardware to sample the pin straps, disable modules in the device, and optionally enable the PS clock PLLs. These hardware actions are not performed after a non-POR reset.

The first software to run is the BootROM code, then the FSBL/User code and system code. All of these steps are shown in Figure 6-1.

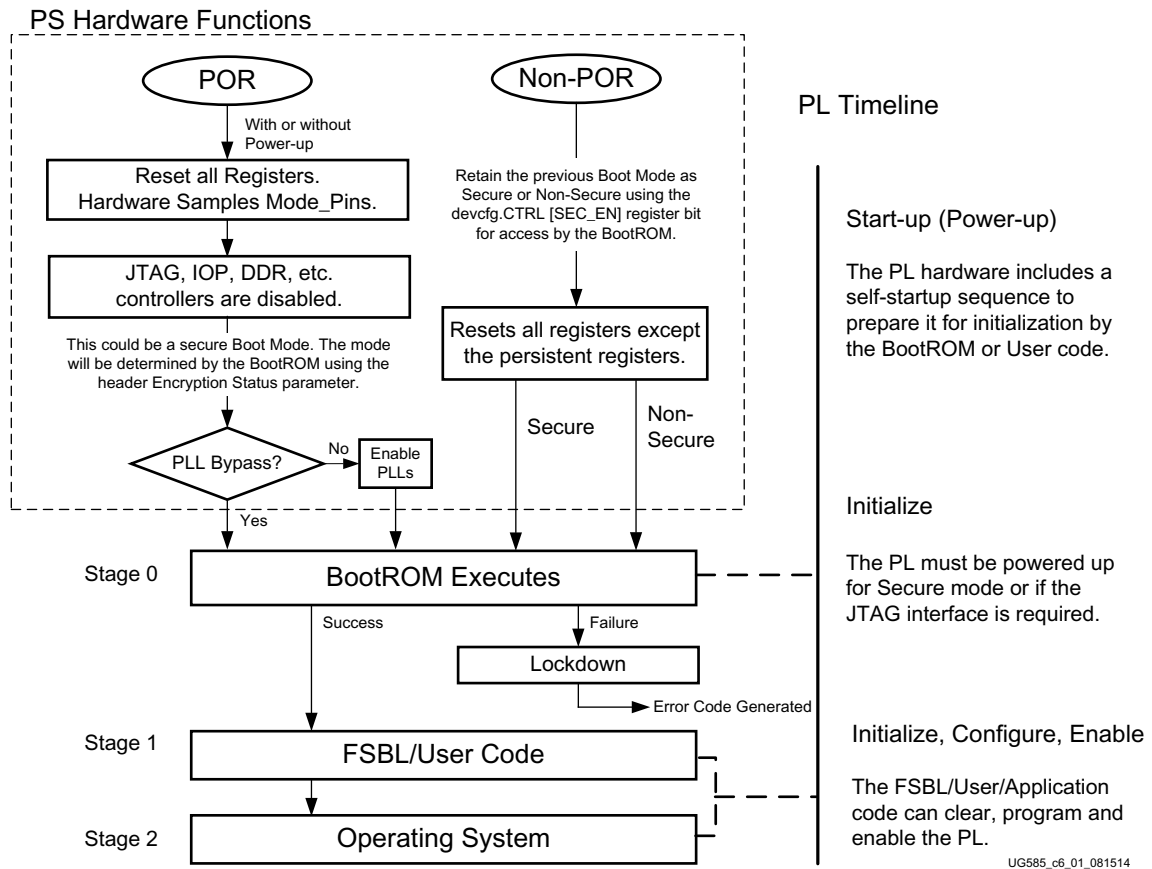

Figure 6-1: PS/PL Boot Process for Hardware and Software

BootROM and Header Parameters

The BootROM header includes a dozen parameters that guide the BootROM execution flow. For example, the header includes a parameter to select the security mode: the Encryption Status parameter. In secure mode, the FSBL/User code, bitstream, and other software are encrypted. The BootROM has the ability to authenticate and decrypt the encrypted FSBL/User code. The header itself is never encrypted.

As another example, the header includes the Length of Image parameter that defines the length of the FSBL/User code that the BootROM loads into the OCM for execution. This code is limited to 192 KB in length. This parameter can be set to zero to indicate the desire to execute code directly

from the boot device (execute-in-place). All of the header parameters are described in section [6.3.2 BootROM Header](#).

The last two functions of the BootROM are to disable access to its ROM code and transfer CPU code execution to the FSBL/User code. The execution of the BootROM is detailed in section [6.3.1 BootROM Flowchart](#).

PL Initialization and Configuration

The PL must be powered-up before it can be initialized and then configured with the bitstream. The power-up and bring-up stages of the PL operate independently of the PS, but PL power up needs to maintain a certain timing relationship with the POR reset signal of the PS. For more details refer to section [6.3.3 BootROM Performance: PS_POR_B De-assertion Guidelines, page 179](#).

The PL can be under the control of FSBL/User code using GPIOs or serial interfaces to external devices. Internally, the BootROM and FSBL/User code can determine the state of the PL power. FSBL/User code can receive interrupts when the PL power state changes.

The PL boot process has four stages: start-up, initialize, configure, and enable. The start-up stage is self-timed after power is ramped-up to a stable state. The initialization stage clears the SRAM cells in the PL to prepare it for programming by the bitstream (configuration stage). The functional PS-PL interfaces are then enabled under PS software control. The BootROM code does not configure the PL, but it can read its status to determine when it can enable the PL JTAG chain and also when it needs to use the HMAC/AES decryption hardware.

Secure PS Images and PL Bitstreams

The secure environment starts with an encrypted boot process where the PS software acts as the system master and the BootROM reads an encrypted FSBL/user code image from the selected flash memory device and processes it using the hardened, PL based Hash-based Message Authentication Code (HMAC) and an Advanced Encryption Standard (AES) module with a Cipher Block Chaining Mode (CBC). These modules are accessed from the PS through the DevC interface and the downstream Processor Configuration Access Port (PCAP) located in the PL.

The BootROM verifies that the PL has power before attempting to decrypt the FSBL/User code. After the PS has finished executing the BootROM, the PL can be configured by the FSBL/user software using an encrypted bitstream or the PL can be configured or reconfigured later.

The low-level secure environment starts at the I/O pin activity and all potential access points to the PS operating environment. The secure operating environment is maintained through the BootROM execution and transferred to a secure software operating environment.

Various device configuration functions and operating examples are described in section [6.4 Device Boot and PL Configuration](#). The details of secure boot are covered in [Chapter 32, Device Secure Boot](#). Security at the operating system level are described in [WP429, TrustZone Technology Support in Zynq-7000](#). The BootROM can also authenticate files using RSA, refer to section [32.2.5 RSA Authentication](#).

Software Developers Guide and Kit

The boot modes and operations are summarized in chapter 3 of the [UG821 Zynq-7000 Software Developers Guide](#). The chapter describes boot methods and ways to program the hardware using the FSBL. The software developers guide also discusses software architectures, tools, and various boot environments, including Linux U-Boot.

The software developers kit (SDK) can be used to develop and debug bare-metal applications. It can also be used to create FSBL/User code boot images and application programs running on an operating system.

6.1.1 PS Hardware Boot Stages

The PS hardware boot stages include power supply ramping, clocking, resets, pin strap sampling and PLL initialization. The PL can be powered up while the PS boots up. The PL boot process is described in section [6.1.7 PL Boot Process](#).

External PS Control Pins

Within 45 clock cycles of the PS_CLK reference clock, the hardware samples the seven Boot Mode strap pins (see [Figure 6-4](#)) and stores their settings in read-only registers. The strap pins define the initial voltage sensitivity for the MIO input buffers, select the JTAG chain route, and select the flash device that contains the boot image. Development boards automatically deassert the PS_POR_B reset pin after the board is powered-up. These boards also include a POR reset button that can be used to generate a POR reset. A non-POR system reset can be generated using the PS_SRST_B reset pin. The details of the PS hardware boot functions are described in section [6.2 Device Start-up](#).

PS PLL Initialization

The PS PLLs are enabled by MIO pin 6, the BOOT_MODE[4] strap pin. When the PLLs are enabled, the execution of the BootROM is delayed until the PLL outputs lock. If the PLLs are not enabled, the PS_CLK reference clock input pin is bypassed around the PLLs and the clock subsystem is driven at the frequency of PS_CLK input. The PLL clocks are described in section [6.2.3 Clocks and PLLs](#) and in [Chapter 25, Clocks](#).

6.1.2 PS Software Boot Stages

The PS software boot process is controlled by the BootROM and then the FSBL/User code. The BootROM code operation is influenced by the boot strap pins, the BootROM Header, and what the BootROM code detects in the system.

Stage 0 (BootROM: BootROM Header)

Hard-coded BootROM executes on the primary CPU (CPU 0) after a power-on reset (POR) or non-POR system reset (PS_SRST_B, debug, watchdog, software). The BootROM reads the BootROM Header programmed into the boot flash device to determine the boot flow and transitions to stage 1. After the hardware boot sequence, both CPUs start executing the same BootROM code

located at address 0x0 (where the BootROM is initially located) to determine their own identity. Note that single-core devices contain one processor, dual-core devices contain two. CPU 1, when present, parks itself by executing the WFE instruction. CPU 0 continues to execute the BootROM.

Stage 1 (FSBL / User code)

This is generally the First Stage Boot Loader, but it can be any user-controlled code. Refer to [UG821](#), *Zynq-7000 SoC Software Developers Guide* for details about the FSBL.

Stage 2 (U-Boot / System / Application)

This is generally the system software, but it could also be a second stage boot loader (SSBL). This stage is also completely within user control and is not described in this chapter. Refer to [UG821](#), *Zynq-7000 SoC Software Developers Guide* for details about FSBL and stage 2 images.

6.1.3 Boot Device Content

The boot device can store multiple components and multiple versions of the components:

- BootROM Header (required by BootROM)
- FSBL/User code ELF file (required by BootROM)
- PL Bitstream (not accessed by BootROM)
- System/Application ELF file (not accessed by BootROM)

The BootROM Header is detailed in section [6.3.2 BootROM Header](#). The FSBL/User code requirements are described in [UG821](#), *Zynq-7000 SoC Software Developers Guide*.

6.1.4 Boot Modes

The boot modes include the four master boot mode devices and two JTAG slave boot modes.

Flash Devices (Master Mode Boot)

When the system boots from a flash memory device, it is considered a Master Mode boot. The following boot devices are described in subsections of section [6.3 BootROM Code](#):

- Quad-SPI with optional Execute-in-Place mode
- SD Memory Card
- NAND
- NOR with optional Execute-in-Place mode

Specific devices that Xilinx recommends for each boot interface are listed in [AR# 50991](#).

JTAG (Slave Mode Boot)

The JTAG boot mode is considered a Slave Mode boot and is always a non-secure boot mode. The JTAG chain can be configured in cascade or independent mode. During the boot sequence, the chain is configured according to the setting of the MIO [2] boot strapping pin. Normally, the system is configured for cascade mode. When the TRM refers to JTAG boot mode, it means JTAG cascade mode unless stated otherwise. The JTAG interface is enabled in all non-secure boot modes.

- Cascade JTAG chain (most popular):
 - Access DAP and TAP controllers through PL JTAG.
- Independent JTAG chain (common):
 - Access TAP controller through PL JTAG.
 - Access DAP controller through EMIO JTAG via SelectIO pins after configuring the PL with a bitstream.
- Independent JTAG chain (rarely used):
 - Access TAP controller through PL JTAG.
 - Access DAP controller through MIO PJTAG.

The JTAG interfaces are discussed in section [6.4.5 PL Control via User-JTAG](#) and detailed in [Chapter 27, JTAG and DAP Subsystem](#).

6.1.5 BootROM Execution

The BootROM execution begins soon after a POR or non-POR reset. A POR reset causes the Hardware Boot stage to occur and then starts the BootROM execution. A non-POR reset skips the hardware stage and starts the BootROM execution almost immediately.

The BootROM executes the on-chip ROM code to perform the system boot process. The BootROM disables all access to the ROM code before transferring code execution over to the FSBL/User code. Details of how the system memory is remapped are shown in [Figure 6-11, page 204](#).

Early in the BootROM execution, it sets up the APU and performs some self-checking. It reads the boot mode pin information and, if the boot mode is not JTAG, the BootROM configures the controller for the selected boot device. The BootROM reads the BootROM Header to further configure the system for the desired boot process. In addition to the BootROM Header, the boot device provides the first stage boot loader (FSBL) and/or user code that takes over system control when the BootROM is done.

The boot device can also provide an image for the operating system, refer to [UG821, Zynq-7000 SoC Software Developers Guide](#). BootROM execution is detailed in section [6.3.1 BootROM Flowchart](#). The BootROM Header is described in [6.3.2 BootROM Header](#).

Secure Boot

The BootROM can operate in non-secure or secure mode depending on the configuration setup by the BootROM Header. In secure mode, the FSBL/User code is moved from the flash device, decrypted and written into the OCM memory. The CPU executes the code from the OCM.

If the system is booted in secure mode and then reset by a non-POR reset with a BootROM Header that indicates a non-secure boot, then the system goes into a secure lockdown with error code 0x201A.

BootROM Header Search

If the BootROM does not detect a valid BootROM Header, the BootROM performs a search function to find another BootROM Header. The search function is described in section [6.3.10 BootROM Header Search](#). BootROM Header search is supported for Quad-SPI, NAND and NOR boot modes. The BootROM Header is never encrypted and the search functions work with an encrypted or un-encrypted FSBL/User code images.

BootROM Execution Influencers

The BootROM is influenced by different conditions. Some are intentional, others are not.

- Pin strapping
- Reset signal pins
- Validity of the BootROM Header (checksum for header search)
- BootROM Header boot mode and conflicts that cause lockdown errors

Error Detection, Device Lockdown and Error Codes

If the BootROM detects an error while executing the BootROM Header, it locks down the system and generate an error code. There are two lockdown types:

- Secure Lockdown (no access to device, requires a POR to restart the system).
- Non-secure Lockdown (JTAG might be enabled and any system reset can restart the system to run the BootROM again).

When a lockdown occurs, the error code is written into the slcr.REBOOT_STATUS register. The error codes are listed in [Table 6-20, page 200](#).

6.1.6 FSBL / User Code Execution

The FSBL/User code executes after the BootROM is finished. The FSBL/User code reconfigures the PS as needed and optionally configures the PL. The BootROM loads the FSBL/User code into the OCM unless the execute-in-place option is enabled. The FSBL/User code operations:

- Initialize the PS using the PS7 Init data that is generated by Vivado tools (MIO, DDR, etc.)
- Program the PL using a bitstream (if provided).
- Load the second stage bootloader or bare-metal application code into DDR memory.
- Hand off system control to the second stage bootloader or bare-metal application.

The FSBL/User code requirements are explained in [UG821, Zynq-7000 SoC Software Developers Guide](#). FSBL code can be generated by the Vivado SDK for bare-metal applications.

The user code can force the device into a secure lockdown, if desired, by writing to the devcfg.CTRL [FORCE_RST] bit. A POR reset is required to start up the system from this and all secure lockdowns.

FSBL Image Fallback and Multiboot

If the FSBL detects an error or wants to use a different FSBL image, then it writes the boot image address to the devcfg.MULTIBOOT_ADDR [MULTIBOOT_ADDR] field and performs a software system reset. This is briefly described in section 6.3.11 [MultiBoot](#). Also refer to [UG821, Zynq-7000 SoC Software Developers Guide](#) for information on how to use both fallback and multiboot.

6.1.7 PL Boot Process

The PL boot process includes start-up, initialization, configuration, and enable.

- Start-up (power-up the PL voltage).
- Initialization (using PS software or INIT/PROGRAM control pins).
- Configuration (through PS PCAP, JTAG, or PL ICAP).
- Enable PS-PL Interface (using PS software).

These steps and their subcomponents are illustrated in [Figure 6-1, page 151](#).

6.1.8 PL Configuration Paths

The PL can be configured and reconfigured by PS software in secure or non-secure mode. The PCAP path is the most commonly deployed method as it does not require that the PL be pre-programmed with a bitstream. The PL can also be configured by the TAP controller on the JTAG chain in non-secure mode. Multiplexing of the datapath is done in the PL configuration module using the devc.CTRL [PCAP_MODE] and [PCAP_PR] bits. Also refer to section 6.5 [Reference Section](#).

- JTAG debug using TAP Controller (common for development):
 - Non-secure
 - Initialize and configure the PL through the TAP controller.
- PS PCAP path (common for deployment):
 - Secure or non-secure.
 - Initialize and configure the PL through the device configuration interface (DevC).
- ICAP path (not a common option):
 - Secure or non-secure.
 - Reconfiguration only by logic instantiated in the PL.

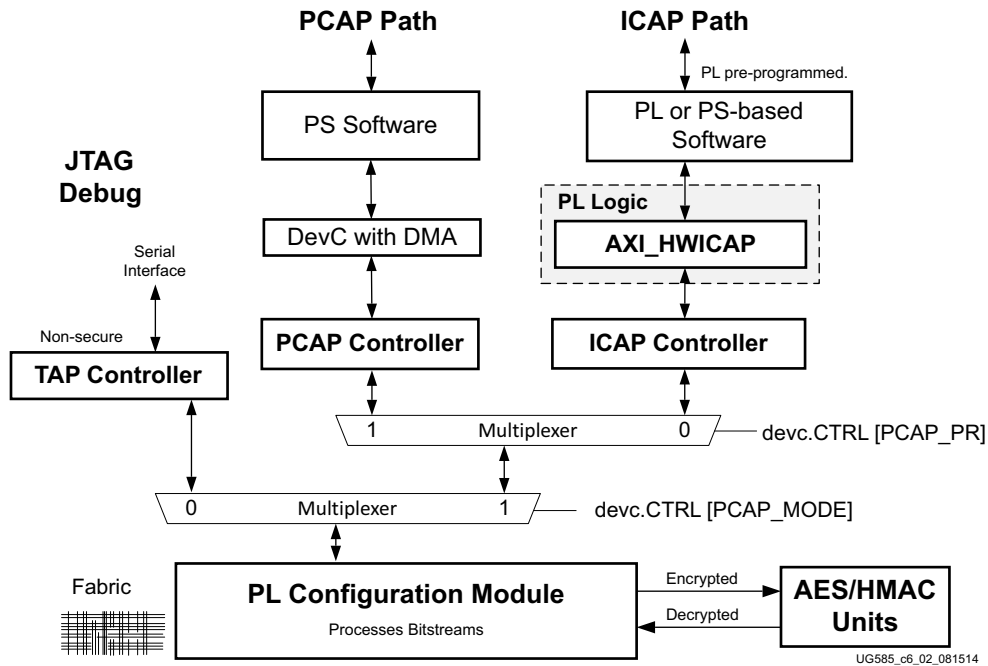

Figure 6-2: PL Configuration Paths

TAP Controller

The TAP controller can be assessed by any of the JTAG interfaces as shown in [Figure 27-1, page 708](#). To enable the JTAG debug path, make sure the other controllers are finished using the PL configuration module and then set the [PCAP_MODE] bit = 0. The TAP controller is often used in a debug/development environment. This path is always non-secure.

PCAP Controller

The connection for the PCAP controller is explained in section [6.1.9 Device Configuration Interface](#). To enable the PCAP path, make sure the other controllers are finished using the PL configuration module and then set the [PCAP_MODE] and [PCAP_PR] bits = 1. The PCAP path is often used for deployment. This path can be secure or non-secure.

ICAP Controller

The connection for the ICAP controller is explained in the product guide and data sheet for the AXI_HWICAP pcore. To enable the ICAP path from the ICAP controller to the PL configuration module, make sure the other controllers are finished using the PL configuration module and then set the [PCAP_MODE] bit = 1 and the [PCAP_PR] bit = 0. The ICAP path is used when a MicroBlaze processor is controlling the PL reconfiguration or as an alternative to the PCAP path. This path can be secure or non-secure. For secure mode, the system must maintain a secure environment as described in [UG821, Zynq-7000 SoC Software Developers Guide](#) for the FSBL and, for the operating system, [WP429, TrustZone Technology Support in Zynq-7000 SoC](#).



IMPORTANT: The ICAP must be configured for x32 mode in the PL design. If the ICAP is configured for x8 mode or x16 mode, the PS connection to the PCAP will break after the PL bitstream has loaded.

6.1.9 Device Configuration Interface

The device configuration interface (DevC) includes three logic modules to initialize and configure the PL under PS software control (PCAP path), manage device security, and access the XADC. The DevC also includes a set of control/status registers for these three main functional modules.

Features

- PCAP Bridge with DMA is used by the PS software to configure the PL and decrypt images. This provides the PS software with a path to the PL Configuration module. This path can:
 - Decrypt a secure FSBL/User code.
 - Process secure and non-secure PL bitstreams; download/upload concurrently.
 - Process PL bitstream compression commands as needed.
- Security Management Module monitors system activity to maintain a secure operating environment.
 - Basic device security management.
 - Enforce system-level security, including debug controls.
- XADC interface provides the PS software with access to the Analog-to-Digital converters in the PL, refer to [Chapter 30, XADC Interface](#).
 - Serial interface.
 - Alarm and over-temperature interrupts.

Block Diagram

The top part of [Figure 6-3](#) connects to the PS AXI interconnect and the lower part connects to the PL.

DevC Control and Status Registers

The APB registers are used to configure and read the status of the DevC. They are memory mapped in PS address space `0xF800_7000`, refer to [Table 4-7, page 117](#). The registers are summarized in [Table 6-26, page 224](#).

Interrupts and Status Bits

Interrupts can be generated from any of the three modules in the DevC block. These interrupts are enabled and controlled by register bits before driving the DevC interrupt signal (IRQ ID# 40) to the PS system interrupt controller (GIC).

There are interrupts and status bits to determine the state of the PL, the activity of the DMA controller in the PCAP bridge, and for the XADC operations.

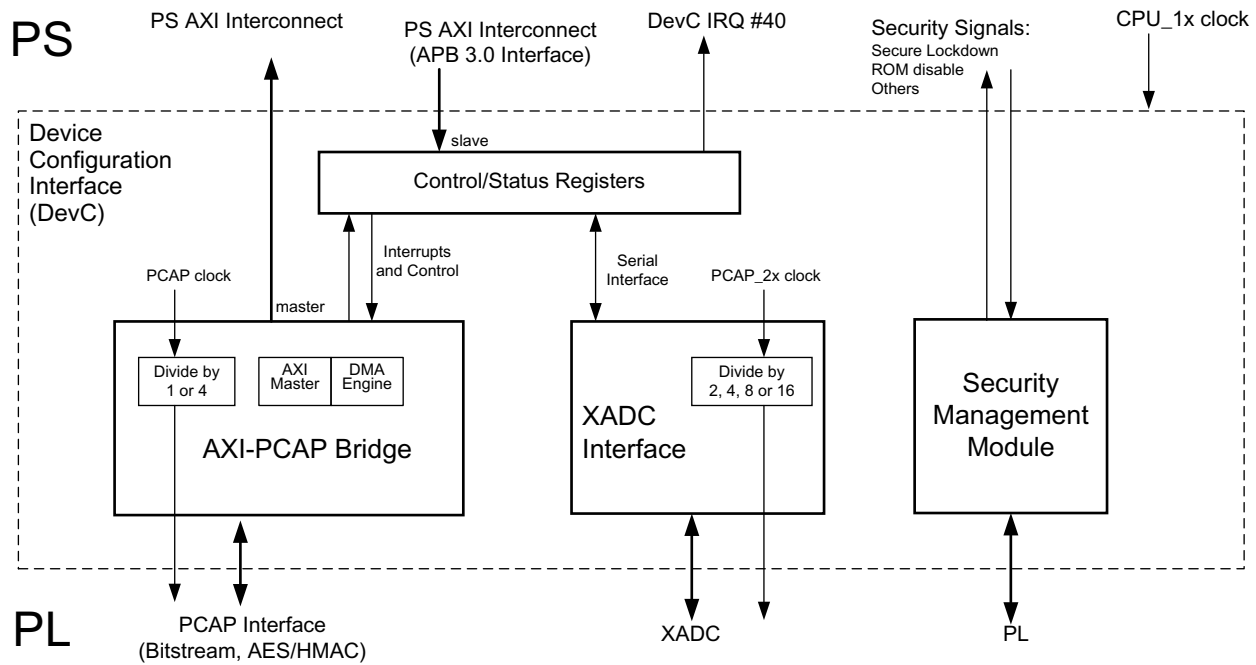

UG585_c6_03_081514

Figure 6-3: DevC Block Diagram

PCAP Bridge Module

For deployment, the PCAP bridge is a main component in the configuration of the PL and to decrypt/authenticate the images. The bridge is described in various subsections of section [6.4 Device Boot and PL Configuration](#).

Device Security Module

The DevC contains a security management module that provides these functions:

- Monitors the system security and can assert a security reset when conflicting status is detected that could indicate inconsistent system configuration or tampering.
- Controls and monitors the PL configuration logic through the APB interface.
- Controls the Arm CoreSight debug access port (DAP) and debug levels.
- Disables the on-chip BootROM code at the end of BootROM execution to protect its contents from being read by setting the write-once devcfg.ROM_SHADOW register.

The device security features and functions are described in [Chapter 32, Device Secure Boot](#).

XADC Interface

The XADC interface is one path to access the hardened analog-to-digital converters in the PL voltage domain. The two other paths and the information on how to access the XADC are described in [Chapter 30, XADC Interface](#).

6.1.10 Starting Code on CPU 1

CPU 0 is in charge of starting code execution on CPU 1. The BootROM puts CPU 1 into the Wait for Event mode. Nothing has been enabled and only a few general purpose registers have been modified to place it in a state where it is waiting at the WFE instruction.

There is a small amount of protocol required for CPU 0 to start an application on CPU1. When CPU 1 receives a system event, it immediately reads the contents of address `0xFFFFFFFF0` and jumps to that address. If the SEV is issued prior to updating the destination address location (`0xFFFFFFFF0`), CPU 1 continues in the WFE state because `0xFFFFFFFF0` has the address of the WFE instruction as a safety net. If the software that is written to address `0xFFFFFFFF0` is invalid or points to uninitialized memory, results are unpredictable.

Only Arm-32 ISA code is supported for the initial jump on CPU 1. Thumb and Thumb-II code is not supported at the destination of the jump. This means that the destination address must be 32-bit aligned and must be a valid Arm-32 instruction. If these conditions are not met, results are unpredictable.

The steps for CPU 0 to start an application on CPU 1 are as follows:

1. Write the address of the application for CPU 1 to `0xFFFFFFFF0`.
2. Execute the SEV instruction to cause CPU 1 to wake up and jump to the application.

The address range `0xFFFFFE00` to `0xFFFFFFFF0` is reserved and not available for use until the stage 1 or above application is fully functional. Any access to these regions prior to the successful start-up of the second CPU causes unpredictable results.

Note: If CPU 1 does not start with the above procedure, it is suggested to reset CPU 1. For more information see [XAPP1079](#), *Simple AMP: Bare-Metal System Running on Both Cortex-A9 Processors*.

6.1.11 Development Environment

For development and debug, the JTAG interface provides access to the DAP and TAP controllers for system control. These controllers provide a wide range of capabilities for the developer. The developer also has the optional ability to access the Arm Test Port User Interface (TPUI) to have a high bandwidth debug datapath from the APU to the debug tools. These test and debug features are described in [Chapter 27, JTAG and DAP Subsystem](#).

In JTAG boot mode, a flash device is not required, but can be part of the system. When booting from a flash device in non-secure mode, the JTAG interface and DAP/TAP controllers can be enabled for debug and test.

In JTAG boot mode, the BootROM disables access to the hard-coded ROM memory, as usual, and then executes the WFE instruction in the CPU. JTAG boot mode has control flexibility for a development environment with access to the PS AXI interconnect via the DAP controller shown in [Figure 5-1, page 121](#).

The JTAG I/O connections are explained in [Chapter 27, JTAG and DAP Subsystem](#). The debug environment is described in [Chapter 28, System Test and Debug](#).

6.2 Device Start-up

This section includes the following subsections:

- section 6.2.1 Introduction
- section 6.2.2 Power Requirements
- section 6.2.3 Clocks and PLLs
- section 6.2.4 Reset Operations
- section 6.2.5 Boot Mode Pin Settings
- section 6.2.6 I/O Pin Connections for Boot Devices

6.2.1 Introduction

The Zynq-7000 device start-up requires proper voltage sequencing and I/O pin control. The flow of the BootROM is controlled by the type of reset, the boot mode pin settings, and the Boot Image. The BootROM expects certain pin connections for the selected boot device.



IMPORTANT: *Zynq-7000 SoC devices have power, clock, and reset requirements that must be met for successful BootROM execution. The data sheets and this section describe the requirements.*

6.2.2 Power Requirements

The BootROM power requirements for the PS and PL are shown in [Table 6-1](#). Power control is discussed in [Chapter 24, Power Management](#). Power supply voltage and ramp time requirements are specified in the data sheet.

Table 6-1: PS and PL Power Requirements

| Boot Option | Secure After POR Reset | PS Power | PL Power |
|---------------------------------|------------------------|----------|--------------|
| NAND, NOR, SD card, or Quad-SPI | Yes | Required | Required |
| | No | Required | Not required |
| PL JTAG and EMIO JTAG | | Required | Required |
| MIO JTAG | | Required | Not required |

In the early stages of BootROM execution, the BootROM checks if the PL is powered up. If it is not powered-up, the BootROM continues with execution. If the PL is powered up, the BootROM initiates a cleaning cycle. The BootROM waits up to 90 seconds for the cleaning to occur. If the cleaning does not finish in this amount of time, then a secure lockdown occurs.

If the PL is needed by the BootROM, it waits for up to 90 seconds for the PL to power-up. If the PL does not power-up in this time frame, then the system shuts down without providing an error code.

PL Power-Down

The PL power-down sequence includes stopping the use of all signals between the PS and PL, disabling the voltage level shifters, and powering off the PL. An example sequence is shown in section [2.4 PS-PL Voltage Level Shifter Enables](#).

6.2.3 Clocks and PLLs

The PS_CLK reference clock is routed to multiple sections of the device, including the three PS clock PLLs. The frequency of the PS_CLK affects the boot time of the device. The PLLs multiply the PS_CLK to generate high frequency clocks for various system clock modules. When needed, the PLLs can be bypassed to deliver the PS_CLK frequency directly to the system clock modules.

If the PLLs are enabled, then the PS_CLK must be stable before the PLLs are enabled and must remain stable. The clock frequency must be within its operating range as specified in the data sheet.

If the PLLs are bypassed, the PS_CLK can be toggled as slow as desired and up to its rated input frequency. This can be used to single-step the bring-up processes, control the clock with software, or operate the system at a low clock frequency. Operating the system at a low clock frequency might preclude the use of some modules within the device (e.g., the USB ULPI clock must be at a lower frequency than the CPU_1x clock).

The device clocks, PS PLLs, and system clock modules are detailed in [Chapter 25, Clocks](#).

Note: The maximum frequency during BootROM execution is 500 MHz across all speed grade specifications.

6.2.4 Reset Operations

There are two types of system resets: POR and non-POR. The details of the system resets are described in [Chapter 26, Reset System](#). All of these resets cause the BootROM to execute.

POR Reset

The POR resets reset the whole system, including all of the registers. All states except the eFuse and BBRAM are lost.

- PS_POR_B pin, described in more detail, below.

Non-POR Resets

Non-POR reset events are recorded in the slcr.REBOOT_STATUS register. A non-POR reset also causes the BootROM to execute, but the BootROM retains knowledge about the security level of the previous boot in the devcfg.CTRL [SEC_EN] bit. Not all of the registers are reset by a non-POR reset, refer to [Table 26-2, page 705](#).

The non-POR reset sources include:

- PS_SRST_B pin, described in more detail, below.
- Internal system resets

External Reset Signal Pins

There are two external reset pins, PS_POR_B and PS_SRST_B:

PS_POR_B: The POR reset is the only reset to sample the boot mode pin strap resistors. For the power-up sequence, the PS_POR_B input is required to be asserted Low until V_{CCPINT} , V_{CCPAUX} and V_{CCO_MIO0} have reached their minimum operating levels to ensure PS eFUSE integrity.

For the power-down sequence, at least one of the four following conditions is required before V_{CCPINT} reaches 0.80V (the condition must be held True until V_{CCPINT} reaches 0.40V to ensure PS eFUSE integrity):

- PS_POR_B input is asserted Low,
- Reference clock to the PS_CLK input is disabled,
- V_{CCPAUX} is lower than 0.70V, or
- V_{CCO_MIO0} is lower than 0.90V.

Note: PS_POR_B must not be de-asserted during a certain timing window relative to when the last PL power supply starts to ramp. Asserting PS_POR_B during this window can cause a lock-down event. Refer to section [6.3.3 BootROM Performance: PS_POR_B De-assertion Guidelines](#), page 179 for more details.

PS_SRST_B: This reset is used to force a system reset. It can be tied or pulled High, and can be High during the PS power supply ramp-up. The PS_SRST_B reset is a non-POR reset.

Note: The PS_SRST_B signal must not be asserted while the BootROM is executing from a POR reset, otherwise a lock-down event occurs and prevents the BootROM from completing the system boot process. To recover from this type of lockdown, the PS_POR_B reset must be asserted. The time taken by Boot ROM to complete its execution and handoff to the FSBL/user application depends on the several factors. Please refer to [Boot Time Reference](#), page 222 for details on how to arrive at the boot time for a specific user configuration.

Reset Signal Sequencing

The reset sequencing required for boot are illustrated in [Figure 6-4](#). The effects of the resets are described in this chapter and in [Chapter 26, Reset System](#). If PS_SRST_B is asserted while the BootROM is executing, then a system lockdown occurs without an error code being generated.

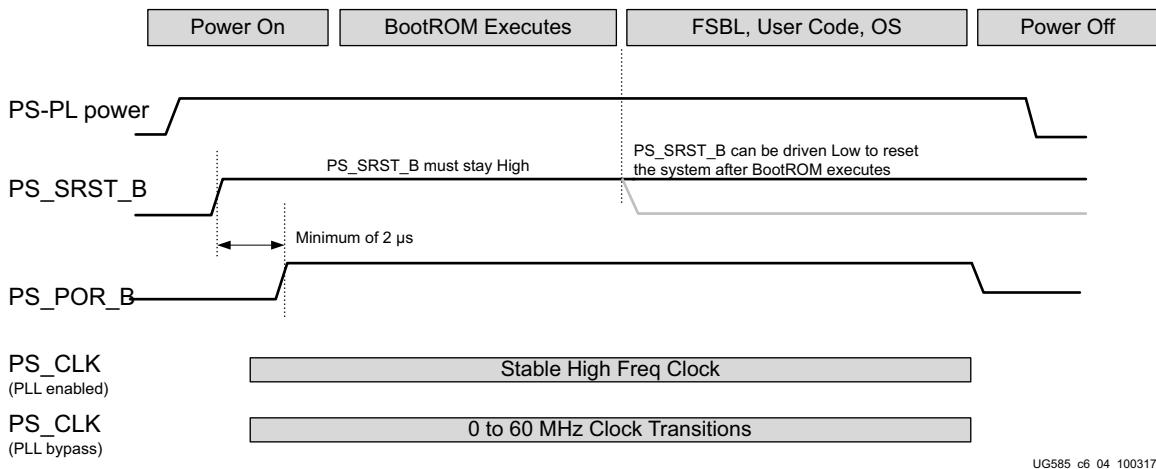

Figure 6-4: Power and Reset Sequencing Waveform

Internal Resets

The internal resets are all non-POR resets. Resets are described in [Chapter 26, Reset System](#).

- Software controlled reset: write 1 to slcr.PSS_RST_CTRL [SOFT_RST].
- Watchdog timers: AWDT0, AWDT1, and SWDT controllers.
- JTAG interface and debug.

Reset Reason

The type of reset that last occurred (reset reason) is recorded in the slcr.REBOOT_STATUS register. This register also includes the BootROM error code, when it is generated. The register is accessible to the BootROM and FSBL/User code. The Reboot Status register is reset by a POR reset, but preserved by a non-POR reset.

Table 6-2: Reboot Status Register

| slcr.REBOOT_STATUS | Bit | Source |
|----------------------|-------|--|
| [REBOOT_STATE] | 31:24 | R/W bit field that remains persistent through all non-POR resets. |
| Reserved | 23 | Reserved. |
| [POR] | 22 | PS_POR_B reset signal. This is the only reset set after a POR reset. |
| [SRST_B] | 21 | PS_SRST_B reset signal. |
| [DBG_RST] | 20 | Debug command in the DAP controller. |
| [SLC_RST] | 19 | Write to the slcr.PSS_RST_CTRL [SOFT_RST] bit. |
| [AWDT1_RST] | 18 | CPU 1 watchdog timer. |
| [AWDT0_RST] | 17 | CPU 0 watchdog timer. |
| [SWDT_RST] | 16 | System watchdog timer. |
| [BOOTROM_ERROR_CODE] | 15:0 | BootROM, refer to Table 6-20 . |

System Reset Effects

The effects of the system resets (POR and non-POR) are summarized in [Table 6-3](#).

Table 6-3: System Reset Effects

| Reset Type | POR | Non-POR |
|-----------------------------------|----------------------|--------------------------------------|
| Sample Pin Straps | Yes | No |
| Initialize PS PLLs ⁽¹⁾ | Yes, by the hardware | Yes, by the BootROM |
| PS RAM (FIFOs, buffers, etc.) | Cleared | Cleared |
| IOP clocks | Disabled | Disabled |
| BootROM executes | Yes | Yes |
| Retains previous boot mode | No | Yes |
| Reboot Status register | Resets it | Accumulates the system reset type. |
| Device Registers | All | Persistent registers. ⁽²⁾ |
| Resets PL | Yes | Yes |

Notes:

1. The Boot_Mode [4] pin strap determines if the PLLs are enabled or bypassed.
2. There are a number of register and individual register bit fields that are not affected by a non-POR reset. Refer to [Table 26-2, page 705](#) for a list.

User Defined Persistent Bit Field

The 16-bit user defined persistent bit field is located in the devcfg.MULTIBOOT_ADDR register, bits 31:16. These register bits are R/W and persist through a non-POR reset (PS_SRST, watchdog, etc.). The [USERDEF_PERSISTENT] bit field can be used to pass status and command information between one non-POR FSBL/User code boot and another.

6.2.5 Boot Mode Pin Settings

There are 7 boot mode strapping pins that are hardware programmed on the board using MIO pins [8:2]. They are sampled by the hardware soon after PS_POR_B deasserts and their values are written to software readable registers for use by the BootROM and user software. The board hardware must connect each strapping pin, MIO [8:2], to a 20 kΩ pull-up or pull-down resistor. The encoding of the mode pins are shown in [Table 6-4](#). A pull-up resistor specifies a logic 1 and a pull-down resistor specifies a logic 0.

Five pins, BOOT_MODE[4:0], are used to select the boot mode, JTAG chain config, and if the PLLs are bypassed. The sampled values of these pins are written into the slcr.BOOT_MODE [BOOT_MODE] and [PLL_BYPASS] bit fields.

- Boot modes are explained in section [6.3 BootROM Code](#).
- Boot strap pins are listed in [Table 6-4](#).
- JTAG chains are described in section [6.4.5 PL Control via User-JTAG](#).
- PLLs are described in section [6.2.3 Clocks and PLLs](#).

Two pins, VMODE[1:0], are used to select the voltage signaling levels for the two MIO voltage banks. The sampled values of these pins are written into the slcr.GPIOB_DRVR_BIAS_CTRL [RB_VCFG] and [LB_VCFG] bit fields. The VMODE settings are used by the BootROM to initially set the MIO_PIN_{53:00} registers to the selected I/O signaling standard. VMODE[0] controls MIO pins 15:0 and VMODE[1] controls MIO pins 53:16. A pull-up causes the BootROM to select LVCMOS18. A pull-down selects LVCMOS33 which is deemed compatible with LVCMOS25. The MIO pin I/O programming descriptions are described in the slcr.MIO_PIN_00 register definition in [Appendix B, Register Details](#).

The FSBL/User code can change the initial boot mode settings for the JTAG chain, the PLLs and the I/O voltage standard for the MIO pins on individual MIO pin basis.

Table 6-4: Boot Mode MIO Strapping Pins

| Pin-signal / Mode | MIO[8] | MIO[7] | MIO[6] | MIO[5] | MIO[4] | MIO[3] | MIO[2] |
|--|---------------|---------------|---|--|--------------|--------------|---|
| | VMODE[1] | VMODE[0] | BOOT_MODE[4] | BOOT_MODE[0] | BOOT_MODE[2] | BOOT_MODE[1] | BOOT_MODE[3] |
| Boot Devices | | | | | | | |
| JTAG Boot Mode; cascaded is most common⁽¹⁾ | | | | 0 | 0 | 0 | JTAG Chain Routing⁽²⁾ 0: Cascade mode 1: Independent mode |
| NOR Boot⁽³⁾ | | | | 0 | 0 | 1 | |
| NAND | | | | 0 | 1 | 0 | |
| Quad-SPI⁽³⁾ | | | | 1 | 0 | 0 | |
| SD Card | | | | 1 | 1 | 0 | |
| Mode for all 3 PLLs | | | | | | | |
| PLL Enabled | | | 0 | Hardware waits for PLL to lock, then executes BootROM. | | | |
| PLL Bypassed | | | 1 | Allows for a wide PS_CLK frequency range. | | | |
| MIO Bank Voltage⁽⁴⁾ | | | | | | | |
| | Bank 1 | Bank 0 | Voltage Bank 0 includes MIO pins 0 thru 15. Voltage Bank 1 includes MIO pins 16 thru 53. | | | | |
| 2.5 V, 3.3 V | 0 | 0 | | | | | |
| 1.8 V | 1 | 1 | | | | | |

Notes:

1. JTAG cascaded mode is most common and is the assumed mode in all the references to JTAG mode except where noted.
2. For secure mode, JTAG is not enabled and MIO[2] is ignored.
3. The Quad-SPI and NOR boot modes support execute-in-place (this support is always non-secure)
4. Voltage Banks 0 and 1 must be set to the same value when an interface spans across these voltage banks. Examples include NOR, 16-bit NAND, and a wide TPIU test port. Other interface configuration may also span the two banks.

6.2.6 I/O Pin Connections for Boot Devices

The BootROM expects certain external pins to be connected. Some pins connections are necessary for all boot modes. Others depend on the boot mode pin straps and the BootROM Header. After the BootROM executes, user code can reconfigure the I/O pin connections as desired.

- Connections required for all boot configurations:
 - PS power supply
 - PS_POR_B, PS_SRST_B, and PS_CLK_B
- MIO connections for specific boot devices
 - Quad-SPI (auto detect 1, 2, 4, or 8-bit interface)
 - SD memory card (SDIO 0, MIO pins 40-47)
 - NAND (auto detect 8 or 16-bit interface)
 - NOR (CS 0)
 - JTAG (PLJTAG interface), normally used in Cascade Chain mode

6.3 BootROM Code

The BootROM executes after a system reset to configure the PS as described in the introduction. This section provides the details of the boot process, the format of the BootROM Header, the BootROM performance with examples, the functions and needs of each boot device, the various boot images, and the boot failure error codes.

This section includes the following subsections:

- [6.3.1 BootROM Flowchart](#)
- [6.3.2 BootROM Header](#)
- [6.3.3 BootROM Performance](#)
- [6.3.4 Quad-SPI Boot](#)
- [6.3.5 NAND Boot](#)
- [6.3.6 NOR Boot](#)
- [6.3.7 SD Card Boot](#)
- [6.3.8 JTAG Boot](#)
- [6.3.9 Reset, Boot, and Lockdown States](#)
- [6.3.10 BootROM Header Search](#)
- [6.3.11 MultiBoot](#)
- [6.3.12 BootROM Error Codes](#)
- [6.3.13 Post BootROM State](#)
- [6.3.14 Registers Modified by the BootROM – Examples](#)

6.3.1 BootROM Flowchart

Zynq-7000 configuration starts after a system reset. The overall boot process is illustrated in [Figure 6-1, page 151](#) and the BootROM execution is shown in [Figure 6-5, page 171](#). CPU 0 executes the BootROM code with the DAP and TAP JTAG controllers disabled. The DDR memory controller and other peripherals are not initialized by the BootROM.

The PL power-up and initialization sequences can occur in parallel with or after the PS start-up. If the BootROM needs the PL powered up, then early in the BootROM execution the BootROM writes to the devcfg.CTRL [PCFG_PROG_B] bit and waits for the devcfg.STATUS [PCFG_INIT] bit to assert before proceeding with BootROM execution.

PL power is needed for PCAP access and image decryption. The BootROM tests the PL state before accessing its resources using a 90 second timeout. The PROGRAM_B device pin must be held High during the boot process. Holding the PROGRAM_B device pin Low during the boot process causes a device lockdown event.

Secure/Non-Secure

For security reasons, CPU 0 is always the first device out of reset among all master modules within the PS. CPU 1 is held in an WFE state. While the BootROM is running, JTAG is always disabled, regardless of the reset type, to ensure security. After the BootROM runs, JTAG is enabled if the boot mode is non-secure.

The BootROM code is also responsible for loading the FSBL/User code. When the BootROM releases control to stage 1, user software assumes full control of the entire system. The only way to execute the BootROM again is by generating one of the system resets. The FSBL/User code size, encrypted and unencrypted, is limited to 192 KB. This limit does not apply with the non-secure execute-in-place option.

The PS boot source is selected using the BOOT_MODE strapping pins (indicated by a weak pull-up or pull-down resistor), which are sampled once during power-on reset (POR). The sampled values are stored in the slcr.BOOT_MODE register.

The BootROM supports encrypted/authenticated, and unencrypted images referred to as *secure boot* and *non-secure boot*, respectively.

The BootROM supports execution of the stage 1 image directly from NOR or Quad-SPI when using the execute-in-place option, but only for non secure boot images. Execute-in-place is possible only for NOR and Quad-SPI boot modes.

In secure boot, the CPU, running the BootROM code, decrypts and authenticates the user PS image on the boot device, stores it in the OCM, and then branches to it.

In non-secure boot, the CPU, running the BootROM code, disables all secure boot features including the AES unit within the PL before branching to the user image in the OCM memory or the flash device (if execute-in-place is used).

Any subsequent boot stages for either the PS or the PL are your responsibility and are under your control. The BootROM code is not accessible to you. Following a stage 1 secure boot, you can proceed with either secure or non-secure subsequent boot stages. Following a non-secure first stage boot, only non-secure subsequent boot stages are possible.

Boot Sources

There are five possible boot sources: NAND, NOR, SD card, Quad-SPI, and JTAG. The first four boot sources are used in master boot methods in which the CPU loads the external boot image from nonvolatile memory into the PS.

JTAG is the slave boot mode, and is only supported with a non-secure boot. An external host computer acts as the master to load the boot image into the OCM through a JTAG connection. The PS CPU remains in idle mode as the boot image is loaded.

The configuration flow for the BootROM is shown in [Figure 6-5](#).

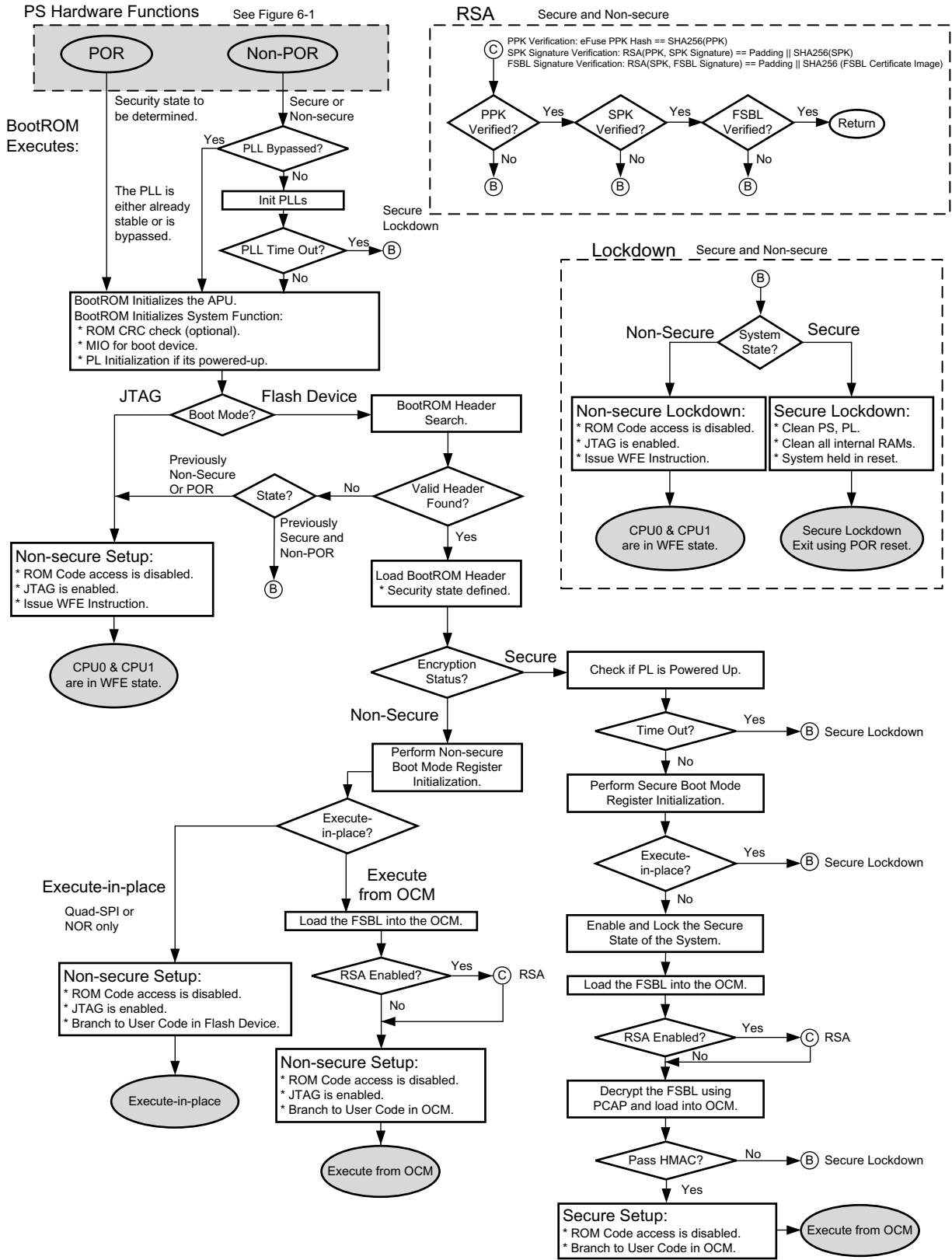

UG585_c6_05_081514

Figure 6-5: BootROM Configuration Flowchart

APU Initialization

The BootROM configures the APU and MIO multiplexer to support the boot process. The state of the MIO pins for each boot mode is described in tables in the Boot Device sections (for example, [Table 6-9](#) for Quad-SPI). The BootROM uses CPU 0 to execute the ROM code. CPU 1 executes the WFE instruction. The caches and TLBs are invalidated. The BootROM configures the MMU and other system resources to meet the needs of the BootROM execution. The state of the APU is described in section [6.3.13 Post BootROM State](#).

Note: FSBL/User code and operating system software must configure the APU for their own needs and should consider the CPU initialization steps described in section [Chapter 3, Application Processing Unit](#).

6.3.2 BootROM Header

The BootROM requires a header for all master boot modes (flash devices). In JTAG slave boot mode, the BootROM Header is not used and the BootROM code does not load the FSBL/User code.

The BootROM Header parameters are shown in [Table 6-5](#) with their word number, byte address offset, and applicability for the three types of device boot modes.

Note: The BootROM Header is referred to as the Boot Image Header in [UG821, Zynq-7000 SoC Software Developers Guide](#). They both refer to the same table of parameters provided in [Table 6-5](#).

Table 6-5: BootROM Header Parameters

| Header Address | 32-bit Word | Parameter | Boot Device | | |
|----------------|-------------|--|---------------------|---------------------|---------------------------------|
| | | | Secure Usage | Non-Secure Usages | |
| | | | OCM | OCM | Execute In Place ⁽⁶⁾ |
| 0x000 - 0x01F | 0 - 7 | Interrupt Table for Execution-in-Place | no | no | yes |
| 0x020 | 8 | Width Detection | Quad-SPI | Quad-SPI | Quad-SPI |
| 0x024 | 9 | Image Identification | yes | yes | yes |
| 0x028 | 10 | Encryption Status | yes | yes | yes |
| 0x02C | 11 | FSBL/User Defined ⁽³⁾ | ~ | ~ | ~ |
| 0x030 | 12 | Source Offset | yes | yes | ~ |
| 0x034 | 13 | Length of Image | yes | yes | set = 0 |
| 0x038 | 14 | FSBL Load Address | ~ | ~ | set = 0 |
| 0x03C | 15 | Start of Execution | yes | yes | yes |
| 0x040 | 16 | Total Image Length | note ⁽¹⁾ | note ⁽²⁾ | set = 0 |
| 0x044 | 17 | QSPI Config Word ,set to 0x01 | ~ | ~ | ~ |
| 0x048 | 18 | Header Checksum | yes | yes | yes |
| 0x04C - 0x097 | 19 - 39 | FSBL/User Defined (76-Byte) ⁽³⁾ | ~ | ~ | ~ |

Table 6-5: BootROM Header Parameters (Cont'd)

| Header Address | 32-bit Word | Parameter | Boot Device | | |
|----------------|-------------|--|--------------|-------------------|---------------------------------|
| | | | Secure Usage | Non-Secure Usages | |
| | | | OCM | OCM | Execute In Place ⁽⁶⁾ |
| 0x0A0 - 0x89F | 40 - 551 | Register Initialization (2048-Byte) ⁽⁴⁾ | yes | yes | yes |
| 0x8A0 - 0x8BF | 552 - 559 | Image Header ⁽³⁾ | yes | yes | yes |
| 0x8C0 - 0x8FF | 560 - 576 | Partition Header | yes | yes | yes |
| 0x900 | 577 and up | FSBL Image or User Code | 192 KB | 192 KB | see ⁽⁵⁾ |

Notes:

1. In secure mode, the Total Image Length parameter is greater than Length of Image parameter because of encryption.
2. In non-secure OCM mode, the Total Image Length parameter must be set equal to the Length of Image parameter.
3. The FSBL/User Defined parameter and FSBL Image and User Code fields are not used by the BootROM code and do not affect the hardware. See UG821, *Zynq-7000 SoC Software Developers Guide* for more information.
4. The addresses that can be accessed by Register Initialization is restricted, see Table 6-7. The secure boot mode has more address restrictions than a non-secure boot.
5. The size of the FSBL image (or User code) for Execute-in-place depends on the allowed capacity of the boot device less the 0x8C0 (the size of the BootROM Header). The maximum Quad-SPI size is described in section 6.3.4 *Quad-SPI Boot*. For NOR, refer to section 6.3.6 *NOR Boot*.
6. To select the execute-in-place feature, set the Length of Image and Total Image Length parameters to 0 and load the PS interconnect address into the Source Offset.

Interrupt Table for Execution-in-Place — 0x000 to 0x01C

Eight 32-bit words are reserved for interrupt mapping. This is useful for execute-in-place for NOR and Quad-SPI devices. It allows the CPU vector table to be managed in two ways. The first is to use the MMU to remap the flash linear address space to 0x0. The second method to manage the vector table location is to use the coprocessor VBAR register. For more information on setting this register, refer to the *Arm v7-AR Architecture Reference Manual* (listed in Appendix A, *Additional Resources*).

Width Detection — 0x020

Width Detection is required for the Quad-SPI boot mode. Ensure that the BootROM Header includes the value of 0xAA995566 so the BootROM can determine the maximum hardware I/O data connection width of the flash device(s). This value helps the BootROM to determine the data width of a single Quad-SPI device (x1, x2, or x4) and to detect a second device in 8-bit parallel I/O configuration. If this value is not present for the Quad-SPI boot mode then the BootROM lockdowns the system and generates an error code. The error code number depends on other conditions. The error codes are listed in Table 6-20, page 200. Details of the detection operation are explained in section 6.3.4 *Quad-SPI Boot*.

Image Identification — 0x024

This word has a mandatory value of 0x584C4E58, 'XLNX'. This value allows the BootROM (along with the header checksum field) to determine that a valid BootROM Header is present. If the value is not

matched, the BootROM code performs a Header search if the boot mode is either Quad-SPI, NAND, or NOR. If the boot mode is SD card, the BootROM lockdowns the system and generates an error code.

Encryption Status — 0x028

Encryption Status determines if the boot is secure (the boot image is encrypted) or non-secure mode. Valid values for this field are:

- 0xA5C3C5A3 Encrypted FSBL/User code (requires eFUSE key source).
- 0x3A5C3C5A Encrypted FSBL/User code (requires battery-backed RAM key source).
- Not 0xA5C3C5A3 or 0x3A5C3C5A. Non-encrypted FSBL/User code (no key).

The eFuse states and the encryption status word determines the source of the encryption key, if any. The valid combination are shown in [Table 6-6](#).

Table 6-6: BootROM Requirements for Encryption Status Word

| eFuse States (described in Table 32-2, page 769) | | | |
|---|-----------|-----------|------------|
| eFuse Secure Boot | Not Blown | Not Blown | Blown |
| BBRAM Key Disable | Not Blown | Blown | Don't Care |
| Encryption Status Word | | | |
| Non-secure | Okay | Okay | Lockdown |
| Secure with BBRAM Key | Okay | Lockdown | Lockdown |
| Secure with eFuse Key | Okay | Okay | Okay |

FSBL/User Defined — 0x02C

This word is used to store the BootROM header version. Refer to [UG821, Zynq-7000 SoC Software Developers Guide](#) for more information. The BootROM does not interpret or use this field.

Source Offset — 0x030

This parameter contains the number of bytes from the beginning of the valid BootROM Header to where the FSLB/User code image resides. This offset must be aligned to a 64-byte boundary and must be at or above address offset 0x8C0 from the beginning of the BootROM Header.

Length of Image — 0x034

This word contains the byte count of the load image to transfer to the OCM. For non-secure mode, the Length of Image equals the Total Image Length parameter and has a maximum value of 192 KB. For secure mode, the Length of Image is set equal to the length of the image after it has gone through the authentication and decryption process steps. In this case, the Length of Image is always less than 192 KB because of the encryption overhead.

A value of zero with a Quad-SPI or NOR flash mode causes the BootROM to execute the FSBL/User code from the associated flash device without copying the image to OCM (execute-in-place).

FSB Load Address — 0x038

Destination address to which to copy the FSBL.

Start of Execution — 0x03C

- This is a byte address that is relative to the start of system memory and is used for both executing the FSBL/User code from the OCM or using the optional execute-in-place feature of Quad-SPI and NOR boot modes. The byte address must be aligned to a 64-byte boundary. FSBL/User code executes from OCM:
 - Execution attempts outside of the OCM memory address space cause a secure lockdown.
 - Non-secure mode: address must be equal to or greater than 0x0 and less than 0x30000.
 - Secure mode: the address must equal 0x0.
- Execute-in-place FSBL/User code:
 - The address must point to a location within the first 16 MB of memory for x4 Quad-SPI and the first 32 MB of memory for NOR and dual x8 parallel Quad-SPI boot modes.

Total Image Length — 0x040

This is the total number of bytes loaded into the OCM by the BootROM from the flash memory.

For non-secure boot, the Total Image Length parameter must be set equal to the Length of Image parameter.

For secure images, the Total Image Length parameter includes the HMAC header, the encryption overhead and the alignment requirements and is always larger than the Length of Image parameter. The Total Image Length parameter is provided by the design tools.

QSPI Config Word — 0x044

QSPI configuration word, hard-coded to 0x01.

Header Checksum — 0x048

This is the checksum value of the header which is checked prior to using the data within the header. The checksum is calculated by summing the words from 0x020 to 0x044 and inverting the result.

FSBL/User Defined — 0x04C to 0x097

This can be used in Bootgen using the `udf_bh` field of the BIF file. Refer to Appendix-A in [UG821, Zynq-7000 SoC Software Developers Guide](#) for more information.

Boot Header Table Offset — 0x098

Pointer to Image Header table.

QSPI Config Word — 0x09C

Pointer to the Partition Header table.

Register Initialization Parameters — 0x0A0 to 0x89C

This region contains 256 pairs of address and data words that can be used to initialize PS registers for the MIO multiplexer, boot device clocks, and other functions before the FSBL/User code is accessed from the boot device; either to copy the image to the OCM or to execute-in-place. The register writes are commonly used to optimize the boot device interface and set its clock frequency to maximize performance.

A register initialization pair appears as two 32-bit words, first a register address, then a register write value. Register initializations can be in any order, and the same register can be initialized with different values as many times as desired. The register initialization is performed prior to copying the FSBL/User code so the user can modify the default reset register values to reduce the time to access the code and process it.

The BootROM stops processing the Register Initialization list when either the address register = 0xFFFF_FFFF or the end of the list (256 address/write data pairs).

Usage of the register initialization parameters are explained in the “Register Initialization to Optimize Boot Times” section of section 6.3.3 [BootROM Performance](#).

Restricted Addresses

The register address space for the Register Initialization address-data writes is restricted. Register addresses outside of the allowed address range cause the BootROM to lockdown the system and generate error code 0x2111. The allowed register accesses depend on the boot mode and are listed in [Table 6-7](#).

These restrictions are enforced by the BootROM. They do not apply when the FSBL/User code begins to execute. The BootROM screens the register initialization writes and disallows certain addresses from being accessed.

Table 6-7: BootROM Accessible Address Ranges for Register Initialization

| Control Registers | Non-Secure Boot Mode | | Secure Boot Mode |
|-----------------------|------------------------|------------------------------------|------------------|
| | Ranges | Exceptions to Range ⁽¹⁾ | |
| UART 1 | E000_1000 to E000_1FFC | ~ | No |
| Quad-SPI | E000_D000 to E000_DFFC | ~ | No |
| SMC | E000_E000 to E000_EFFC | ~ | No |
| SDIO 0 | E010_0004 to E010_0FFC | E010_0058 | No |
| DDR Memory | F800_6000 to F800_6FFC | ~ | No |
| SLCR registers | | | |

Table 6-7: BootROM Accessible Address Ranges for Register Initialization (Cont'd)

| Control Registers | Non-Secure Boot Mode | | Secure Boot Mode |
|--|------------------------|---|--|
| | Ranges | Exceptions to Range ⁽¹⁾ | |
| PLL, Peripheral, AMBA and CPU clock controls | F800_0100 to F800_0234 | Reserved: F800_01B0 PS Reset Ctrl: F800_0200 | PLL, Peripheral and PL clock controls: F800_0100 to F800_01AC |
| SWDT Reset | F800_024C | ~ | |
| SWDT clock, TZ configuration, PS ID code, DDR configuration, MIO pins, SD card WP/CD routing | F800_0304 to F800_0834 | ~ | |
| Reserved | F800_0A00 to F800_0A8C | ~ | |
| Reserved, GPIO and DDR I/O controls | F800_0AB0 to F800_0B74 | ~ | |
| UART 0, USB, I2C, SPI, CAN, GPIO, GigE, TTC, DMAC, SWDT, DDR, DevC, AXI HP | Not accessible | | Not accessible |

Notes:

1. The registers in this column are not accessible by the Register Initialization writes.

FSBL/User Defined — 0x8A0 - 0x8BF

This memory area may be used by the FSBL or User code. Refer to [UG821, Zynq-7000 SoC Software Developers Guide](#) for more information.

FSBL Image or User Code Start Address — 0x8C0

The FSBL Image or User Code must start at or above this location. The location is pointed to by the Source Offset parameter and must be aligned to 64 bytes.

6.3.3 BootROM Performance

The BootROM performance is an important factor to the total bring-up time of the system that includes: Power-up, BootROM execution, FSBL/User code execution, U-boot time, and OS loading time. The entire boot and configuration process is explained in section [6.4 Device Boot and PL Configuration](#).

Below are a few topics related to BootROM execution that include using the Register Initialization mechanism in the BootROM Header to optimize the bandwidth of the flash device interface. The flash device bandwidth is the single most important factor in speeding up boot times.

Typical BootROM Execution

The BootROM time is measured from when the system powers-up to when the BootROM branches to the FSBL/User code:

1. PS Power-up time, see table in section [6.5 Reference Section](#).
2. PS PLL lock time, see [PS PLL Lock Time](#).
3. BootROM CRC check of ROM code (if enabled).
4. PL ready time (T_{POR}) required when the PL is required:
 - Voltage ramp-up – time depends on the power supply performance.
 - PL Cleaning – time depends on the size of the device.
5. BootROM Header register initialization writes to optimize the flash device interface bandwidth.
6. BootROM normally copies FSBL/User code to OCM memory and optionally performs decryption and authentication:
 - BootROM RSA authentication, if enabled by eFuse.
 - BootROM AES/SHA decryption/authentication (secure boot).
7. BootROM branches to FSBL/User code.

Start-up details and PL configuration information is provided in section [6.4 Device Boot and PL Configuration](#).

PS PLL Lock Time

The PLL is enabled by a pin strap. If the PLL is in bypass mode and then enabled by PS software, the PLL will take some time to lock. The length of time is specified by the t_{LOCK_PSPLL} parameter in the data sheet. The programming of the PLLs are described in section [25.10.4 PLLs](#). Also refer to section [6.5 Reference Section](#). The length of the PLL lock time varies, but it is relatively small compared to the other boot stages.

Register Initialization to Optimize Boot Times

The clocking and I/O configuration can be modified before the FSBL/User code is accessed by using the register initialization parameters in the BootROM Header. These settings can be matched to the specific device used and the board layout. Register initialization takes a negligible amount of time, but can have a drastic effect on performance while copying the FSBL/User code to the OCM memory or routing it to the decryption unit in the PL. Many of the optimizations done via register initialization are only available in non-secure boot mode as listed in [Table 6-7, page 176](#). Secure mode optimizations are limited to clocking controls for the clock subsystem (not the IO controller).

There are register initialization optimization examples for each boot device:

- Quad-SPI, [Table 6-10](#)
- NAND, [Table 6-12](#)
- NOR, [Table 6-14](#)
- SD Card, [Table 6-16](#)

CRC Check for BootROM Code Option

After the power-on and hardware sequences are completed, the BootROM begins to execute. If the BootROM 128 KB CRC Enable eFuse is set, then the BootROM performs a CRC on its own code space

at the beginning of the BootROM execution. Enabling the CRC check adds about 25 ms to the BootROM time. Because the CRC check is done before the register initialization parameters are processed, this time cannot be improved by the register initialization mechanism.

PL Considerations

When the PS and PL are powered-up together, the BootROM is delayed until PL power-on sequence (T_{POR}). This delay occurs regardless of whether the BootROM needs to use resources in the PL voltage domain or not. If the PL is powered-up the BootROM senses this and waits for it to be initialized.

When the PL power is required, the BootROM checks to determine if the PL is powered on before accessing modules in the PL. If the PL is powered-up, then it checks to see if the PL clearing process completed. It waits up to 90 seconds ($PS_CLK = 60$ MHz) for the process to be done. A slower PS_CLK frequency means the BootROM will wait longer than the 90 seconds. If the PL is not cleared by this time, then the BootROM locks down the system and generate an error code. After the PL is cleared, the BootROM initializes the PL so it is ready for the bitstream that is loaded by the FSBL/User code.

PL Power-on Reset Time (T_{POR})

T_{POR} is the PL voltage ramp time and it is important to the boot time when PL power is required for the boot process and it is not already powered-up. PL power is needed in the situations listed in [Table 6-1, page 162](#).

In a normal cold power-up, the PS and PL power supplies come up together so there can be some overlap of activities.

If the PL is already powered on when the BootROM needs it, then T_{POR} is not a factor. Refer to the appropriate data sheet, DS187 or DS191 for times. The power-on timing is also discussed in [AR# 55572](#).

In a non-secure boot, when both the PS and the PL are powered on, the BootROM does not wait for the T_{POR} time. The BootROM loads the FSBL/User code into the OCM, and the FSBL starts configuring the PS. Before the PL bitstream is loaded, you might have to wait up to 50 ms for the PL to be ready after it is powered on. To ensure the PL is ready, the user code can check the `devcfg.STATUS [PCFG_INIT]` bit before programming the bitstream. For details, see section [6.5 Reference Section](#).

In secure boot mode, the AES and HMAC units in the PL is used for decryption and authentication of the FSBL. If the board is being powered up for the first time, the BootROM waits for the PL to be ready, which includes the T_{POR} for the PL. If the board was already powered up and only the device is being reset, then because the PL was already powered on and voltage ramp has already taken place, the T_{POR} parameter is not a factor in the PL bring-up time. In this case, you only have to wait for the PL initialization time, which is device dependent.

PS_POR_B De-assertion Guidelines

To prevent security attacks from tampering with the PL power supply voltage, the BootROM checks for PL power stability by sampling power status multiple times. Any change in PL power supply seen at the sampling points is treated as a security attack on the device and the PS enters secure lock down. To prevent secure lock down from occurring in a system, the user needs to ensure that the PL

power is stable before the bootROM checks for its stability. This can be achieved by controlling the timing relationship between de-assertion of PS_POR_B with respect to the last PL power supply starting to ramp. The timing window that defines the above relationship (Secure Lock Down window) is influenced by the following design parameters:

- PS_CLK frequency
- PLL bypass mode
- Efuse CRC 128K enable
- PL power supply ramp rate
- Device size

A timing window calculator that also takes into account PVT variations provides a quick way to assess if the design is exposed to the risk of a secure lock down as described above. The calculator is available through [AR# 63149](#). PS_POR_B must be de-asserted outside the Secure Lock Down window shown in the calculator to avoid the risk.

Note: Tslw(min) and Tslw(max) values can be negative in some cases. This indicates that PS_POR_B needs to be de-asserted before the last PL power supply starts to ramp.

AES Decryption and HMAC Authentication

AES decryption requires the image to be accessed by DMA through the PCAP interface and then be written to OCM memory. HMAC authentication requires another pass through the PCAP interface to access the HMAC unit.

RSA Authentication Time

During execution, the BootROM can authenticate a secure FSBL prior to decryption or a non-secure FSBL prior to execution using RSA public-key authentication. This feature is enabled by triggering the RSA Authentication Enable fuse in the eFuse array.

The RSA authentication time takes about 56 ms for a 128 KB FSBL using a 33.33 MHz PS_CLK, and default register settings (that is, the CPU divider value 4). Under these conditions, the CPU runs at 215 MHz. The CPU divider value can be changed to divide by 2 by the register initialization parameters. This cuts the authentication time in half (28 ms) because the CPU runs at 433 MHz.

BootROM and Image Copy Time

The image copy time and execute time vary greatly depending on the configuration of the boot interface. [Table 6-8](#) lists the BootROM times for the primary boot modes with default and optimized register values. All values assume a 33.33 MHz PS_CLK clock and are for a 128 KB FSBL/User code image size.

Table 6-8: BootROM Times for the Master Boot Modes

| Boot Mode | Non-Secure Boot | | Secure Boot | |
|------------------|-------------------|---------------|-------------------|----------------|
| | Default Regs (ms) | Reg-Init (ms) | Default Regs (ms) | Reg- Init (ms) |
| Quad-SPI (4-bit) | 98.4 | 16 | 100 | 24 |
| Quad-SPI (8-bit) | 72 | 12 | 74 | 20 |
| NAND x8 | 114 | 52 | 120 | 60 |
| NAND x16 | 92 | 50 | 92 | 56 |
| NOR | 72 | 12 | 72 | 22 |
| SD card | 216 | 196 | 216 | 204 |

The boot times in Table 6-8 include the time from the deassertion of the PS_POR_B signal until the BootROM branches to the FSBL image copied into the OCM. This includes PLL lock time, BootROM execution time, PL initialization time, and the time to copy the FSBL to the OCM. For secure boot, it also includes the time to decrypt and authenticate the FSBL through the AES/SHA unit. The PL T_{POR}, RSA authentication time, or the time for the 128 KB CRC check on the BootROM is not included. The PL T_{POR} time includes power-up and internal hardware sequencing.

6.3.4 Quad-SPI Boot

Quad-SPI boot has these features:

- x1, x2, and x4 single device configuration.
- Dual SS, 8-bit parallel I/O device configuration.
- Dual SS, 4-bit stacked I/O configuration.
- Execute-in-place option.



RECOMMENDED: For details on the specific devices that Xilinx recommends for each boot interface, refer to [AR# 50991](#).

Notes:

1. The dual SS, 4-bit stacked I/O device configuration is supported, but the BootROM only searches within the first 16 MB address range. The BootROM accesses the device connected to the QSPI0_SS_B slave select signal.
2. In cases of Quad-SPI boot, if the image is authenticated, then the boot image should be placed at a 32K offset other than 0x0 (the image should not be placed starting at 0x0 offset in Quad-SPI).
3. There are special reset requirements when using more than 16 MBs of Flash memory. For hardware, refer to [AR# 57744](#) for information. For software considerations, refer to [UG821, Zynq-7000 SoC Software Developers Guide](#).
4. Boot Image requirements when using larger than 16MB QSPI and RSA Authentication (refer [AR# 57900](#)).

I/O Configuration Detection

The BootROM can detect the intended I/O width of the Quad-SPI interface using the Width Detection (`0xAA995566`) parameter value and, in the 8-bit parallel case, also using the Image Identification (`0x584C4E58`) parameter value.

4-bit I/O Detection

During the Quad-SPI boot process, the BootROM configures the controller with 4-bit I/O. This configuration includes a single device and the dual 4-bit stacked case. The BootROM reads the first (and, perhaps, only) Quad-SPI device in x1 mode. It reads the Width Detection parameter in the BootROM Header. If the Width Detection parameter is equal to `0xAA995566`, then the BootROM assumes it found a valid header that is requesting a 4-bit I/O configuration. It might be one device or it might be a dual 4-bit stacked configuration. In the latter case, the second device is always ignored by the BootROM, but it might be accessed by user code. After reading the Width Detection parameter in x1 mode, the BootROM attempts to read the parameter in x4 mode. If x4 mode fails, it tries x2 mode. After this, the BootROM uses the widest supported I/O bus width to access the Quad-SPI device.

8-bit I/O Detection

The BootROM also looks for the dual device, 8-bit parallel configuration. In this case, the BootROM only reads the even bits of the BootROM Header because it is only accessing the first device and the header is split across both devices. The BootROM forms a 32-bit word that includes the even bits of the Width Detection (`0x20`) and Image Identification (`0x24`) parameter values. When the BootROM detects this condition, it assumes the system uses the 8-bit parallel configuration and programs the controller for the x8 operating mode. This mode is used for the rest of the boot process. The Quad-SPI I/O configurations are shown in section [12.5 I/O Interface](#).

BootROM Header Search

If the BootROM does not detect a valid header, then the BootROM searches until one is found or the 32 MB search limit is reached. In the 4-bit stacked I/O case, only the first Quad-SPI device is searched and the search is limited to the first 16 MB of memory. The BootROM Header search is described in section [6.3.10 BootROM Header Search](#).

MIO Programming

The values loaded in to MIO_PIN registers during the Quad-SPI boot mode process are shown in [Table 6-9](#). Initially, the BootROM enables 4-bit mode. If the width detection mechanism determines an 8-bit data width, then additional MIO pins are enabled as shown in the table.

Table 6-9: Quad-SPI Boot MIO Register Settings

| Quad-SPI I/O Interface Signal Name | MIO Pin Number | MIO_PIN Register Setting ⁽¹⁾ | Pin State | | |
|--------------------------------------|----------------|---|-----------|----------------------------|---------------------|
| | | | I/O | I/O Buffer Output, Pull-up | External Connection |
| Quad-SPI Boot | | | | | |
| QSPI_CS0 | MIO 1 | 0x0602 | O | Enabled | ~ |
| QSPI_IO[0:3] | MIO 2 to 5 | 0x0602 | I/O | Enabled | Pull up/down |
| QSPI_SCLK0 | MIO 6 | 0x0602 | O | Enabled | Pull up/down |
| not Quad-SPI | MIO 7 | 0x0601 | O | 3-state | Pull up/down |
| QSPI_SCLK_FB_OUT (not used for boot) | MIO 8 | 0x0601 | O | 3-state | Pull up/down |
| not Quad-SPI | MIO 14 to 53 | 0x1601 | I | 3-state | ~ |
| 4-bit Quad-SPI Boot | | | | | |
| QSPI_CS1 | MIO 0 | 0x1601 | I | 3-state | ~ |
| QSPI_SCLK1 | MIO 9 | 0x1601 | I | 3-state | ~ |
| QSPI_IO[4:7] | MIO 10 to 13 | 0x1601 | I | 3-state | ~ |
| 8-bit Quad-SPI Boot | | | | | |
| QSPI_CS1 | MIO 0 | 0x0602 | O | Enabled | ~ |
| QSPI_SCLK1 | MIO 9 | 0x0602 | O | Enabled | ~ |
| QSPI_IO[4:7] | MIO 10 to 13 | 0x1602 | I/O | Enabled, Pull-up | ~ |

Notes:

1. These register settings are for LVCMOS25/33. Change the 6 to a 2 for LVCMOS18 (bits 11:9 change from 011 to 001).

Execute-in-Place Option

For the execute-in-place option, the BootROM uses the linear addressing feature of the Quad-SPI controller for non-secure boot modes. In this case, the initial FSBL/User code must fit inside the first 16 MB of memory for a single device and 32 MB of memory for a x8 dual Quad-SPI device system.

Configuration Register Settings

The BootROM sets qspi.LQSPI_CFG to use these settings:

- CLK_POL: 0, CLK_PH: 0
- BAUD_RATE_DIV: 1 (by 4)
- INST_CODE is set as:
 - x1 mode = 0x03, x2 mode = 0x3B, x4 mode = 0x6B
- DUMMY_BYTE is set as:
 - x1 mode = 0, x2 and x4 mode = 1
- SEP_BUS and TWO_MEM are set if a dual x4 configuration is used

Boot Time Optimizations

The Quad-SPI boot process can be sped up by modifying the operating mode before the process to read the flash contents into OCM begins. You program the BootROM Header Register Initialization parameters to improve boot times or select modes. The Register Initialization parameters are explained at the end of section [6.3.2 BootROM Header](#).

The optimized values for the registers in the following examples are obtained from vendor data sheets. The following examples show the settings for the Quad-SPI interface. These are examples; they might not be optimized for a specific flash device or board design. The settings assume a 33 MHz PS_CLK. If a faster clock is used, then a larger divider must be considered.

The optimizations for the MIO multiplexer, clock controls and other configurations are shown in [Table 6-10](#). If the width or security combination is not listed for a register, then the post BootROM value is used.

Table 6-10: Quad-SPI Boot Time Optimization Register Setting Examples

| Register | Width | Security ⁽²⁾ | Register Value | Description |
|---------------------|-------|-------------------------|----------------|----------------------------------|
| slcr.ARM_CLK_CTRL | All | Both | 0x1F000200 | CPU divisor = 2 (433 MHz) |
| slcr.MIO_PIN_08 | All | Non-secure | 0x00000602 | Feedback clock, 3.3V |
| slcr.LQSPI_CLK_CTRL | All | Non-secure | 0x00000521 | Controller divisor = 5 (173 MHz) |
| | All | Secure | 0x00000621 | Controller divisor = 6 (144 MHz) |
| qspi.Config_reg | All | Non-secure | 0x800238C1 | Baud rate divide-by-2 (86 MHz) |
| qspi.LPBK_DLY_ADJ | All | Non-secure | 0x00000020 | Clock Loopback, 0 delay |
| qspi.LQSPI_CFG | All | Non-secure | ⁽¹⁾ | Device Configuration |

Notes:

1. The qspi.LQSPI_CFG register value depends on the type of device, the interface width and the number of devices attached. Optimized values for the qspi.LQSPI_CFG register are shown in [Table 12-3, page 351](#).
2. In secure mode, the qspi and slcr.MIO_PIN registers are not accessible for optimization using the Register Initialization writes as shown in [Table 6-7](#).

6.3.5 NAND Boot

NAND boot has these features:

- 8-bit or 16-bit NAND flash devices
- Supports ONFI 1.0 device protocol
- Bad block support
- 1-bit hardware ECC support

The boot image must be located within the first 128 MB address space of the NAND flash device for the BootROM Header search function.

Note: The BootROM reads the ONFI compliant parameter information in 8-bit mode to determine the device width. If the device is 16 bits wide, then the BootROM enables the upper eight I/O signals

for a 16-bit data bus. The 16-bit NAND interface is not available in 7z010 dual core and 7z007s single core CLG225 devices.



RECOMMENDED: For details on the specific devices that Xilinx recommends for each boot interface, refer to [AR# 50991](#).

The MIO pin programming for 8- and 16-bit boot modes are listed in [Table 6-11](#).

Table 6-11: NAND Boot MIO Register Settings

| NAND Flash I/O Interface Signal Name (SMC controller) | MIO Pin Number | MIO_PIN Register Setting ⁽¹⁾ | Pin State | | |
|---|----------------|---|-----------|----------------------------|---------------------|
| | | | I/O | I/O Buffer Output, Pull-up | External Connection |
| NAND Boot | | | | | |
| NAND_CE_B | MIO 0 | 0x0610 | I/O | Enabled | |
| non NAND | MIO 1 | 0x1601 | I | 3-state | ~ |
| NAND_ALE | MIO 2 | 0x0610 | O | Enabled | Pull-up/down |
| NAND_WE_B | MIO 3 | 0x0610 | O | Enabled | Pull-up/down |
| NAND_IO[2] | MIO 4 | 0x0610 | I/O | Enabled | Pull-up/down |
| NAND_IO[0] | MIO 5 | 0x0610 | I/O | Enabled | Pull-up/down |
| NAND_IO[1] | MIO 6 | 0x0610 | I/O | Enabled | Pull-up/down |
| NAND_CLE | MIO 7 | 0x0610 | O | Enabled | Pull-up/down |
| NAND_RE_B | MIO 8 | 0x0610 | O | Enabled | Pull-up/down |
| NAND_IO[4:7] | MIO 9 to 12 | 0x1610 | I/O | Enabled, pull-up | ~ |
| NAND_IO[3] | MIO 13 | 0x1610 | I/O | Enabled, pull-up | ~ |
| NAND_BUSY ⁽²⁾ | MIO 14 | 0x0610 | I | 3-state | ~ |
| not NAND | MIO 15 | 0x1601 | I | 3-state | ~ |
| not NAND | MIO 24 to 53 | 0x1601 | I | 3-state | ~ |
| 8-bit NAND Boot | | | | | |
| non 8-bit NAND | MIO 16 to 23 | 0x1601 | I | 3-state | ~ |
| 16-NAND Boot | | | | | |
| NAND_IO[8:15] | MIO 16 to 23 | 0x1610 | I/O | Enabled, pull-up | ~ |

Notes:

1. These register settings are for LVCMOS25/33. Change the 6 to a 2 for LVCMOS18 (bits 11:9 change from 011 to 001).
2. Place 4.7kΩ pull-up resistors on CE and RB near the NAND device.

Boot Time Optimizations

To improve NAND boot time, raise the clock rates, and optimize the I/O protocol by setting the registers listed in [Table 6-12](#). The example values might not be appropriate or optimal for all NAND devices or board layouts. The settings assume a 33 MHz PS_CLK. If a faster clock is used, then a larger divider must be considered.

Table 6-12: NAND Boot Time Optimization Register Setting Example

| Register | Width | Security (Notes:) | Value | Description |
|-------------------|--------|----------------------|------------|---|
| slcr.ARM_CLK_CTRL | Both | Both | 0x1F000200 | CPU divisor = 2 (433 MHz) |
| slcr.SMC_CLK_CTRL | Both | Both | 0x00000921 | Baud rate divisor = 9 (96 MHz, 10.4 ns) |
| smc.set_cycles | Both | Non-secure | 0x00225133 | Timing Parameters: t_rr=2, t_ar=1, t_clr=1, t_wp=2, t_rea=1, t_wc=3, t_rc=3 |
| smc.set_opmode | 8-bit | Non-secure | 0x00000000 | 8-bit width |
| | 16-bit | Non-secure | 0x00000001 | 16-bit width |
| smc.direct_cmd | Both | Non-secure | 0x02400000 | Select ModeReg and UpdateRegs |

Notes:

1. In secure mode, the smc registers are not accessible for optimization using the Register Initialization writes as shown in Table 6-7.

BootROM Operations

The BootROM responds to three flash device situations.

- Bad Blocks: Read and write data reliably.
- ECC: Recover from bit disturbances.
- Partition Memory: dividing flash memory into logical sections (partitions) with consideration for bad blocks.

Bad Block Management

The BootROM manages bad blocks in the following ways:

- It looks for a bad block table (BBT) in the last four blocks of the NAND flash device.
- It supports a primary and secondary BBT with versioning allowing safe software updates.
- If a BBT is not present, the BootROM scans the flash reading the out-of-band (OOB) information to determine the locations of bad blocks.
- The BootROM only performs read operations – it does not write to the flash.

While reading from NAND, the BootROM skips blocks that are marked as bad in the BBT, or in the OOB information if a BBT does not exist.

For example: consider a flash device that has bad blocks located at blocks 1 and 3 (see Figure 6-6):

- When programming the image into the flash device, blocks 1 and 3 must be skipped.
- When reading, the BootROM reads the full user data from the good blocks as they are encountered.

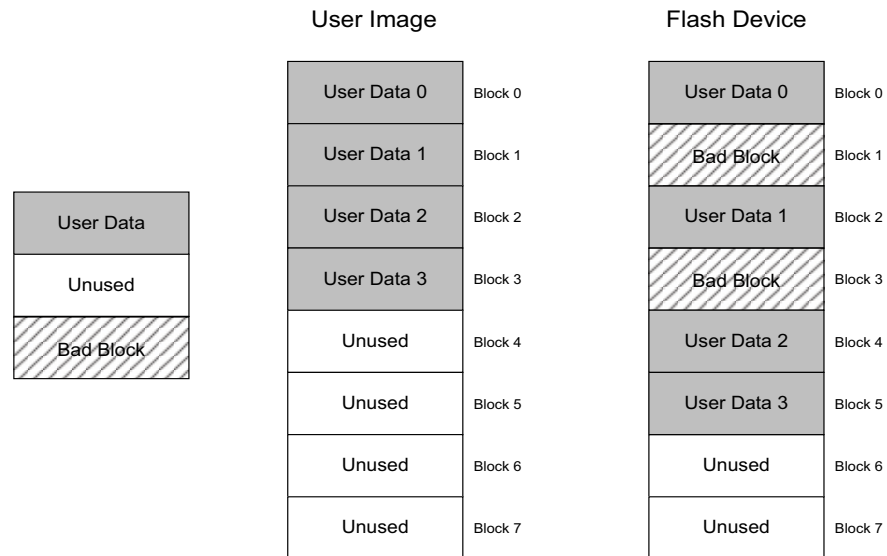

UG585_c6_06_081514

Figure 6-6: NAND Flash Device with Bad Blocks Example

ECC Management

The NAND controller can manage 1 bit of ECC in hardware. For more details on the ECC capabilities of the controller, see [Chapter 11, Static Memory Controller](#). The BootROM is aware of on-die ECC devices and disables the controller ECC checking, allowing the NAND device to take care of ECC.

Memory Partitions

The BootROM treats NAND flash as one continuous partition. From a user perspective, this only affects the Multiboot register. The Multiboot register value written is offset by the number of bad blocks leading up to the target address. Consider the following example:

- Image with two multiboot sections
- Image is 1 MB in size
- Block size is 128 KB
- Second multiboot section starts at 512 KB
- Bad blocks are located at 128 KB and 256 KB offsets

In this scenario, the image should be programmed as one partition, which results in the second multiboot section being offset by 256 KB total (two blocks worth). When the Multiboot register is written, it can be set to 512 KB offset and the BootROM takes care of calculating the new start address based on where the bad blocks reside.

I/O Signal Timing

The BootROM uses the following NAND timing values in the smc.SET_CYCLES register:

- $t_{rr} = 2, t_{ar} = 2, t_{clr} = 1, t_{wp} = 3, t_{rea} = 2, t_{wc} = 5, t_{rc} = 5$

6.3.6 NOR Boot

NOR boot has these features:

- x8 asynchronous flash devices
- Densities up to 256 Mb
- Execute-in-place option

The BootROM does not try to perform any configuration detection of NOR flash devices. When NOR is the selected boot device, the BootROM programs the MIO pins as shown in [Table 6-13](#).

Note: The NOR interface is not available in 7z010 dual core and 7z007s single core CLG225 devices.

Table 6-13: NOR Boot MIO Register Settings

| NOR Flash I/O Interface Signal Name (SMC controller) | MIO Pin Number | MIO_PIN Register Setting ⁽¹⁾ | Pin State | | |
|--|----------------|---|-----------|----------------------------|---------------------|
| | | | I/O | I/O Buffer Output, Pull-up | External Connection |
| SRAM_CE_B[0] | MIO 0 | 0x0608 | O | Enabled | ~ |
| Not used for NOR boot | MIO 1 | 0x1601 | I | 3-state | ~ |
| Not NOR/SRAM | MIO 2 | 0x0601 | I | 3-state | Pull-up/down |
| SRAM_DQ[0:3] | MIO 3 to 6 | 0x0608 | I/O | Enabled | Pull-up/down |
| SRAM_OE_B | MIO 7 | 0x0608 | O | Enabled | Pull-up/down |
| SRAM_BLS_B | MIO 8 | 0x0640 | O | Enabled | Pull-up/down |
| SRAM_DQ[6:7] | MIO 9 to 10 | 0x1608 | I/O | Enabled, pull-up | ~ |
| SRAM_DQ4 | MIO 11 | 0x1608 | I/O | Enabled, pull-up | ~ |
| Not NOR/SRAM | MIO 12 | 0x0608 | I | 3-state | ~ |
| SRAM_DQ5 | MIO 13 | 0x1608 | I/O | Enabled, pull-up | ~ |
| Not NOR/SRAM | MIO 14 | 0x1601 | I | 3-state | ~ |
| SRAM_A[0:24] | MIO 15 to 39 | 0x0608 | O | Enabled | ~ |
| Not NOR/SRAM | MIO 40 to 53 | 0x1601 | I | 3-state | ~ |

Notes:

1. These register settings are for LVCMOS25/33. Change the 6 to a 2 for LVCMOS18 (bits 11:9 change from 011 to 001).

The BootROM uses the following NOR timing values in the smc.SET_CYCLES register:

- w_e_n asserts 2 clocks after $cs_n, t_{ta}=1, t_{pc}=2, t_{wp}=5, t_{ceoe}=2, t_{wc}=7, t_{rc}=7$

Boot Time Optimizations

To improve NOR boot time, raise the clock rates, and optimize the I/O protocol by setting the registers listed in [Table 6-14](#). The example values might not be appropriate or optimal for all NOR devices or board layouts. The settings assume a 33 MHz PS_CLK. If a faster clock is used, then a larger divider must be considered.

Table 6-14: NOR Boot Time Optimization Register Setting Example

| Register | Security | Value | Description |
|-------------------|------------|------------|---|
| slcr.ARM_CLK_CTRL | both | 0x1F000200 | CPU divisor = 2 (433 MHz) |
| slcr.SMC_CLK_CTRL | both | 0x00000D21 | Baud rate divisor = 13 (66 MHz, 15 ns) |
| smc.set_cycles | Non-secure | 0x0002AA77 | Timing Parameters: we_n asserts 2 clocks after cs_n, t_ta=1, t_pc=2, t_wp=5, t_ceoe=2, t_wc=7, t_rc=7 |
| smc.set_opmode | Non-secure | 0x00000110 | 32-beat bursts, 8-bit width |
| smc.direct_cmd | Non-secure | 0x00400000 | Select UpdateRegs |

6.3.7 SD Card Boot

SD card boot supports these features:

- Boot from standard SD or SDHC cards
- FAT 16/32 file system
- Up to 32 GB card densities

Note: The SD card boot mode is not supported in 7z010 dual core and 7z007s single core CLG225 devices.

Note: The SD card boot mode does not support header search or multiboot.

BootROM Steps

The BootROM performs these steps in SD card boot mode:

1. Initializes the MIO pins listed in [Table 6-15](#).
2. Configures SDIO_CLK_CTRL to a divisor of 32 and SD_CLK_CTL_R with a value of 1 (divide by 2).
3. Sets the SD controller to operate in 4-bit mode and use 3-byte addressing.
4. Tests the interface.
5. Reads BOOT.BIN from the root of the SD file system and copies it into OCM after parsing the required BootROM Header.
6. BootROM transfer CPU execution to code downloaded into the OCM.

Table 6-15: SD Card Boot MIO Register Settings

| SDIO I/O Interface Signal Name | MIO Pin Number | MIO_PIN Register Setting ⁽¹⁾ | Pin State | | |
|--------------------------------|----------------|---|-----------|----------------------------|---------------------|
| | | | I/O | I/O Buffer Output, Pull-up | External Connection |
| Not SD card boot | MIO 0, 1 | 0x1601 | I | 3-state | ~ |
| Not SD card boot | MIO 2 to 8 | 0x0601 | I | 3-state | Pull-up/down |
| Not SD card boot | MIO 9 to 39 | 0x1601 | I | 3-state | ~ |
| SDIO_0_CLK | MIO 40 | 0x0680 | O | Enabled | ~ |
| SDIO_0_CMD | MIO 41 | 0x0680 | O | Enabled | ~ |
| SDIO_0_DATA[0:3] | MIO 42:45 | 0x1680 | I/O | Enabled, pull-up | ~ |

Notes:

1. These register settings are for LVCMOS25/33. Change the 6 to a 2 for LVCMOS18 (bits 11:9 change from 011 to 001).

Note: Production devices do not test the Card Detection status. For preproduction devices, refer to [AR# 52016](#).

File Partitions

For the BootROM to read the BOOT.BIN file, the SD card must be partitioned so that the first partition is a FAT 16/32 file system. Additional non-FAT partitions are permitted, but the BootROM does not read the other partitions.

Boot Page Access

When the SD card is reset, it defaults to providing access to the boot page. The BootROM assumes that the boot page is accessible when it executes. If user code changes to a different page and a Zynq system reset occurs without resetting the SD card, then the BootROM will not be able to read the BootROM Header from the boot page of the SD card.

BootROM Header Search and Multiboot

In SD card boot mode, the BootROM does not perform a header search and does not support multiboot.

Boot Time Optimizations

To improve the boot time of SD card, set the CPU clock divider to 2 instead of 4. The setting assumes a 33 MHz PS_CLK. If a faster clock is used, then a larger divider must be considered.

Table 6-16: SD Card Boot Time Optimization Register Setting Example

| Register | Security | Value | Description |
|-------------------|----------|------------|---------------------------|
| slcr.ARM_CLK_CTRL | Both | 0x1F000200 | CPU divisor = 2 (433 MHz) |

6.3.8 JTAG Boot

There are two JTAG controllers in the Zynq device: the TAP and DAP controllers. The test access port (TAP) controller can control the PL configuration process and other functions in the PL. Detailed information regarding the TAP controller can be found in [UG470, 7 Series FPGAs Configuration User Guide](#). The debug access port (DAP) controller is in the application processing unit (APU), see [Chapter 3, Application Processing Unit](#). Detailed DAP controller information can be found in [Chapter 27, JTAG and DAP Subsystem](#). There are two chaining modes to access these JTAG controllers: cascade and independent modes, as shown in [Figure 6-7](#).

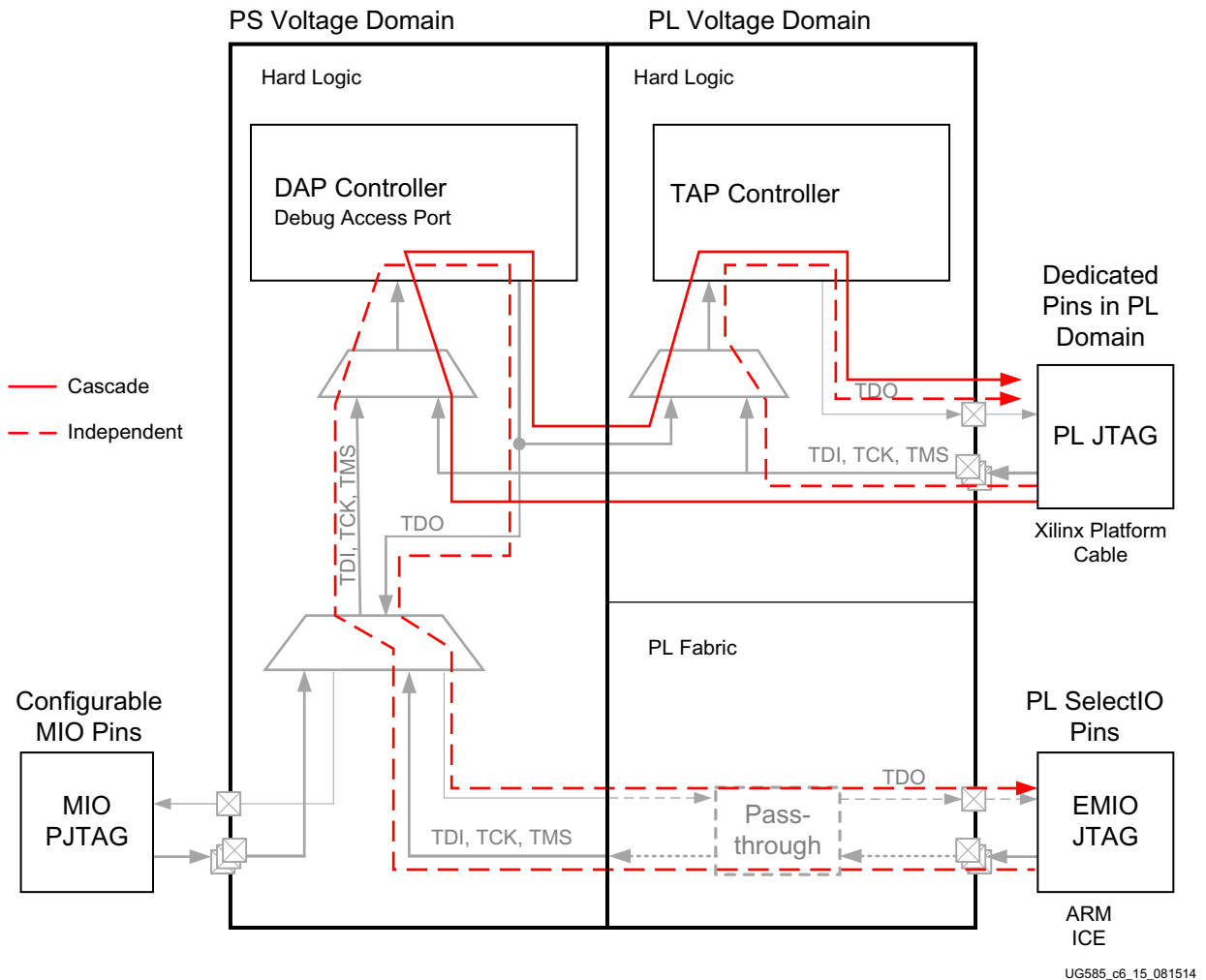

Figure 6-7: PS Cascade and Independent JTAG Chain Diagram

JTAG Enable/Disable Control

The DAP and TAP controllers are controlled by a few mechanisms.

- Cascade versus Independent mode
- Enable/disable DAP and TAP controllers

- Permanently disable JTAG

The JTAG connections can be enabled and disabled using the devcfg.CTRL [JTAG_CHAIN_DIS] bit. It is set = 1 to disable JTAG to protect the PL from unwanted JTAG accesses.

The DAP controller is enabled by setting the devcfg.CTRL [DAP_EN] bit = 111. Any other value causes the DAP controller to be bypassed. This bit is lockable by setting the devcfg.LOCK [DBG_LOCK] bit = 1. Once locked, it can only be unlocked with a POR reset.

Table 6-17: JTAG Requirements and Control

| Function | DAP Controller | TAP Controller |
|---|--------------------------|--|
| Power requirements | PS and PL | PS and PL |
| PL configuration | Not required | Not required for Cascade mode. Required for Independent mode. |
| devcfg.CTRL [JTAG_CHAIN_DIS] | Must = 0 | Must = 0 |
| devcfg.CTRL [DAP_EN] | Must = 111 | Must = 111 for Cascade mode. Don't care for Independent mode. |
| APB register space is unlocked with the wrong key | Disabled until POR reset | Not affected |

The DAP and TAP controllers can be permanently disabled by blowing the JTAG Chain Disable eFuse. Once the eFuse is blown, the controllers can never be accessed again. The software can read the state of the eFuse bit using the devcfg.STATUS [EFUSE_JTAG_DIS] bit.

Note: If software attempts to unlock the APB register space in the DevC module without the proper key, then this disables the DAP controller until the next POR reset is issued. This condition can be detected by reading the devcfg.STATUS [ILLEGAL_APB_ACCESS] bit.

When the JTAG Boot mode is selected, the BootROM disables access to all security-related items, enables the JTAG port, and halts the CPU by executing the WFE instruction. It is the User's responsibility to manage downloading the boot image into OCM or DDR memory through the DAP controller before waking up the CPU and continuing the boot process.

Example: JTAG Boot Sequence

JTAG Boot mode is always non-secure; the AES unit is disabled and encrypted images are not supported. The JTAG boot and PS/PL configuration flows are shown in Figure 6-7. The sequence is as:

1. PS and PL are powered-on; PS_CLK is stable.
2. PS_POR_B reset deasserts.
3. BootROM begins to execute and determines the boot mode.
4. BootROM performs CRC self-check, if enabled.
5. BootROM programs VMODE on MIO.
6. BootROM disables all security features and enables the DAP controller.
7. BootROM enables JTAG path(s):
 - a. **Cascade:** JTAG chain is set to cascade; the DAP and TAP controllers are accessible using the PL JTAG interface.

- b. **Independent:** JTAG chain is set to independent mode; the TAP controller is accessible via the PL JTAG interface and the DAP controller is accessed through the EMIO JTAG. In this case, the BootROM waits up to 90 seconds for you to program the PL (using the TAP controller) for the EMIO JTAG connection.
8. BootROM shuts down and leaves CPUs running the wait for event (WFE) instruction:
 - a. **Cascade:** BootROM shuts down and releases system control to the JTAG interface for the TAP and DAP controllers.
 - b. **Independent:** BootROM waits until the PL is initialized and then shuts down. The EMIO JTAG interface for the DAP controller must be routed through the PL using a bitstream to be operational.
9. User can access the DAP controller for PS system debug:
 - a. **Cascade:** First device on the PL JTAG interface chain.
 - b. **Independent:** Single device on the EMIO JTAG interface chain.
10. User can access the TAP controller to configure PL:
 - a. **Cascade:** Second device on the PL JTAG interface chain.
 - b. **Independent:** Single device on the PL JTAG interface chain.

Note: For high system reliability when using the L2-cache, set the `slcr.L2C_RAM` register to the value of `0x0002_0202` as explained in [AR# 54190](#).

Cascaded JTAG Chain Mode

The controllers are normally accessed using the cascaded JTAG chain mode. In cascade mode, both controllers are accessed using the PL JTAG interface pins; the TDI signal from the interface goes to the DAP controller. The TDO signal from the DAP controller is daisy chained to the TAP controller. The TDO signal from the TAP controller goes to the JTAG interface. The DAP registers and data are the last to be shifted into the JTAG chain.

- DAP controller, then the TAP controller.
- PL configuration not required.
- Both controllers must be enabled.
- Instructions and data must not adversely affect the unintended target.

Independent JTAG Chain Mode

The independent JTAG chain mode connects the TAP controller to the PL JTAG interface and provides time for the user to use the TAP controller to configure the PL with a bitstream that routes the DAP controller signals to the EMIO JTAG interface on the SelectIO pins as shown in [Figure 6-7, page 191](#). The BootROM waits up to 90 seconds for the PL configuration to complete before it enables the DAP controller and continues with the boot process. If the PL is not configured in time, then the system locks down.

- TAP controller is accessed through the PL JTAG pins and is used to configure the PL.
- DAP controller becomes accessible after the PL is configured with a bitstream.

In independent mode, the TAP controller behaves like the TAP controller in a Xilinx 7 series FPGA.

EMIO PJTAG Interface for Independent Mode

The PL must be configured with a bitstream to enable the EMIO PJTAG interface to connect to the DAP controller. After boot, the PL can be initialized by asserting the PROGRAM_B signal and then loading the bitstream into the PL after the DONE signal is asserted. This can be done to enable the EMIO PJTAG interface to control the DAP controller in independent JTAG mode.

Note: This functionality is only supported on production silicon and requires for the system to be booted in independent JTAG boot mode. In this mode, the BootROM waits until the PL is self initialized, then enables the PS-PL level shifters, enables the PL JTAG interface, and issues the WFE instruction on the CPU.

MIO PJTAG Interface for Independent Mode

The DAP controller can interface to the MIO PJTAG interface, but it requires the FSBL/User code to program the MIO multiplexer using the slcr.MIO_PIN_xx registers. The MIO PJTAG interface can be routed to one of four sets of MIO pins as shown in [Table 2-4, page 53](#). PL power is not required for the MIO PJTAG interface and DAP controller to be used.

The TAP controller cannot program the MIO multiplexer. You must boot from a flash device that includes FSBL/User code that configures the MIO multiplexer for the MIO PJTAG interface. After the MIO multiplexer is programmed, the DAP controller is accessible using the MIO PJTAG interface.

MIO Pin States for JTAG Boot Mode

The values for the MIO registers in the JTAG boot mode state are shown in [Table 6-18](#). These values are valid for cascade and independent JTAG boot mode.

Table 6-18: MIO Pin States for JTAG Boot Mode

| MIO Pin | MIO_PIN Register Setting Value ⁽¹⁾ | Pin State | | |
|----------------|---|-----------|--------------------|---------------------|
| | | I/O | I/O Buffer (GPIOB) | External Connection |
| MIO pin [0:1] | 0x1601 | I | 3-state, pull-up | ~ |
| MIO pin [2:6] | 0x0601 | I | 3-state | Pull-up/down |
| MIO pin [7:8] | 0x0601 | O | 3-state | Pull-up/down |
| MIO pin [9:53] | 0x1601 | I | 3-state, pull-up | ~ |

Notes:

1. These register values are based on the VMODE [0, 1] strapping pins. The register values shown are for LVCMOS 25/33. For LVCMOS18, use: 0x1201 and 0x0201 (bits 11:9 change from 011 to 001).

6.3.9 Reset, Boot, and Lockdown States

Reset State

When reset is asserted (PS_POR_B or PS_SRST_B), all of the I/O pins go to a 3-state mode and all registers are reset except those listed in [Table 26-2, page 705](#). When reset de-asserts, then the

BootROM begins to execute to configure the PS. The default reset values for the device are shown [Appendix B, Register Details](#).

Boot State

The BootROM will modify MIO registers depending on the boot mode. The user can program the Time Optimization registers using the Register Initialization parameters in the BootROM Header.

- Quad-SPI Boot
 - [Table 6-9: Quad-SPI Boot MIO Register Settings](#)
 - [Table 6-10: Quad-SPI Boot Time Optimization Register Setting Examples](#)
- NAND Boot
 - [Table 6-11: NAND Boot MIO Register Settings](#)
 - [Table 6-12: NAND Boot Time Optimization Register Setting Example](#)
- NOR Boot
 - [Table 6-13: NOR Boot MIO Register Settings](#)
 - [Table 6-14: NOR Boot Time Optimization Register Setting Example](#)
- SD Card Boot
 - [Table 6-15: SD Card Boot MIO Register Settings](#)
 - [Table 6-16: SD Card Boot Time Optimization Register Setting Example](#)
- JTAG Boot
 - [Table 6-17: JTAG Requirements and Control](#)
 - [Table 6-18: MIO Pin States for JTAG Boot Mode](#)

Lockdown State

The lockdown state differs between secure and non-secure mode. In secure mode, all interfaces are disabled until a POR reset occurs. An error code is signaled on the INIT_B signal as described in section [6.3.12 BootROM Error Codes](#).

Note: When a non-secure LockDown occurs while booting from a Flash device, the BootROM sets the devcfg CTRL [PCFG_PROG_B] bit = 0. This prevents the user from being able to program the PL until the bit is cleared. The [PCFG_PROG_B] bit can be cleared using a software debugger.

The lockdown values for the MIO registers are shown in [Table 6-19](#)

MIO Pin State

The MIO Register pin settings for system reset and secure/non-secure lockdown boot are listed in [Table 6-19](#).

Table 6-19: MIO Pin States for Reset, and Lockdown Boot Mode

| MIO Pin | MIO_PIN Register Setting | | Pin State | | |
|----------------|--------------------------|--------------------|-----------|--------------------|---------------------|
| | Reset Value | Lockdown Value (1) | I/O | I/O Buffer (GPIOB) | External Connection |
| MIO pin [0:1] | 0x1601 | 0x1601 | I | 3-state, Pull-up | ~ |
| MIO pin [2:6] | 0x0601 | 0x0601 | I | 3-state | Pull-up/down |
| MIO pin [7:8] | 0x0601 | 0x0601 | O | 3-state | Pull-up/down |
| MIO pin [9:53] | 0x1601 | 0x1601 | I | 3-state, Pull-up | ~ |

Notes:

1. These register values are based on the VMODE [0, 1] strapping pins. The register values shown are for LVCMOS 25/33. For LVCMOS18, use: 0x1201 and 0x0201 (bits 11:9 change from 011 to 001).

6.3.10 BootROM Header Search

The BootROM reads the BootROM Header and performs two check to verify that the header is valid. It looks to see that the Image Identification parameter contains 0x584C4E58 and that the Header Checksum parameter matches the checksum calculated by the BootROM. If either of these tests fail, then the BootROM Header address increments by 32 KB and the tests are repeated. The header search is part of the BootROM flow and occurs after a POR or non-POR reset. The header search is not supported in SD card boot; a valid BootROM Header is assumed to be in the boot page of the SD card.

The header search function is shown in [Figure 6-8](#). Normally the device boots from the first header but in the event the BootROM detects an issue with the checksum or Image Identification parameter, it looks for the next BootROM Header. The BootROM continues to search until it finds a valid header or reaches the end of the search window.

- BootROM looks for Image Identification parameter XLNX at 0x024.
- Header checksum calculated by the BootROM matches Header Checksum parameter 0x048.

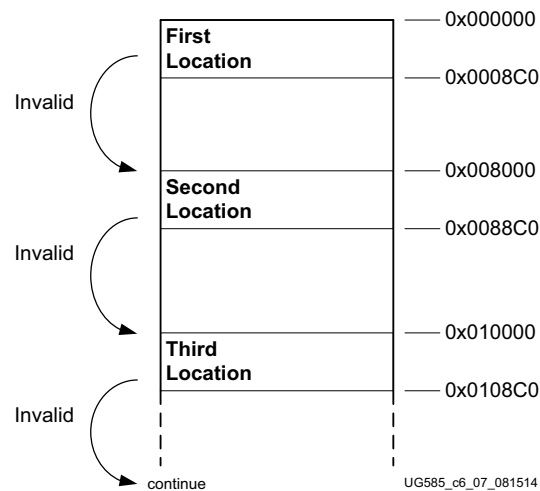

Figure 6-8: BootROM Header Search

The BootROM Header search mechanism protects against:

- An update that was started on the first image but the system was interrupted after erasing the section requiring an update.
- The write operation began but the write process did not finish.

The BootROM Header search mechanism does not protect against:

- The memory holding the BootROM Header becoming corrupt.
- A complete header was written but it did not pass the tests. If a header is non-functional, this might lead to a system lockdown.

The BootROM Header search does not verify the integrity of the header beyond what is listed above. If the header indicates an invalid operation or includes instructions that contradict each other, then the BootROM might generate a system lockdown. The lockdown error codes are listed in section [6.3.12 BootROM Error Codes](#).

BootROM Header Search Stepping and Range

The BootROM searches on 32-KB boundaries until a valid header is detected or the end of the range is encountered. The header search is done for all boot devices except SD card. The search occurs after a POR or non-POR reset including after a Multiboot operation.

The BootROM searches within a limited address space on the boot device:

- NAND: first 128 MB
- NOR: first 32 MB
- Quad-SPI, signal/dual SS with 4-bit I/O: first 16 MB
- Quad-SPI, dual SS with 8-bit Parallel I/O: first 32 MB
- SD card: single image in boot page, no searching

6.3.11 MultiBoot

Multiboot is a feature that allows the FSBL or User code to select the BootROM Header from multiple images on the boot device. To select an image, the FSBL/User code writes the base memory address location of the BootROM Header into the devcfg.MULTIBOOT_ADDR [MULTIBOOT_ADDR] bit field and then generates a non-POR system reset. The BootROM tries to fetch the BootROM Header located at that address. If the BootROM determines that the header is not valid, it performs a BootROM Header search by incrementing the MULTIBOOT_ADDR register until a valid header is found or the end of the range is detected. The range depends on the boot mode and is given in the [BootROM Header Search Stepping and Range](#) section of section 6.3.10 [BootROM Header Search](#).

Note: In secure mode, multiboot is not supported when using an eFuse key. Fallback and multiboot are discussed in this below and in [UG821, Zynq-7000 SoC Software Developers Guide](#).

Multiboot is shown in [Figure 6-9](#) along with the BootROM Header search function.

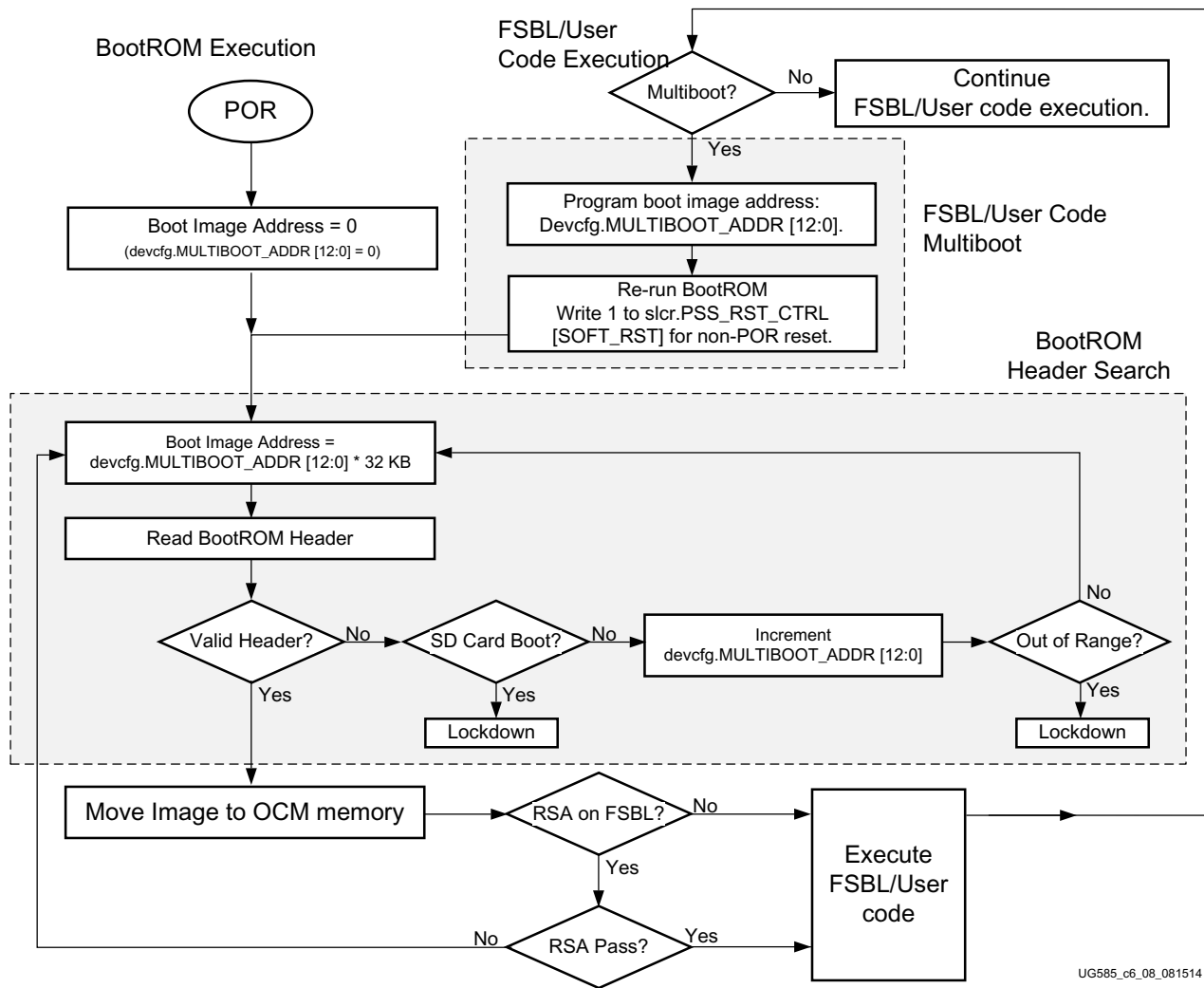

Figure 6-9: BootROM Header Search and FSBL/User Code Multiboot Flowchart

Multiboot Programming Steps

1. Determine the physical byte address. The address must be aligned to 32 KB.
2. Divide the physical memory address by 32 KB (shift out the 15 LSBs). Write the upper address bits into the devcfg.MULTIBOOT_ADDR [MULTIBOOT_ADDR] field.
3. Perform a software system reset by writing to the slcr.PSS_RST_CTRL [SOFT_RST] register bit.

When the BootROM executes after the non-POR reset, it looks for the BootROM Header pointed to by the devcfg.MULTIBOOT_ADDR [MULTIBOOT_ADDR] field.

6.3.12 BootROM Error Codes

The BootROM can detect an error while processing the BootROM Header or while processing the FSBL/User code for decryption and authentication. When a boot failure occurs, the BootROM puts the device into either a secure or non-secure lockdown; an Error Code is normally generated. The BootROM flowchart with error conditions is shown in Figure 6-5. The error codes are listed in Table 6-20.

The error code is visible by observing a bit pulse train on the INIT_B pin (secure lockdown) or by reading the slcr.REBOOT_STATUS [BOOTROM_ERROR_CODE] bit field (non-secure lockdown).

1. INIT_B pin observations:
 - In secure mode INIT_B pulses the 16-bit error code.
 - In non-secure mode INIT_B drives Low, indicating a failure. JTAG is enabled.
2. JTAG access to error code register read:
 - When JTAG is enabled, the DAP controller can be used to read the error code in the slcr.REBOOT_STATUS [BOOTROM_ERROR_CODE] register field.

The INIT_B pulses are meant to be visually read with an LED on the INIT_B pin. The pulses are active-High. A long Low pulse on the pin indicates a 1 and a short pulse indicates a 0. The bit order is LSB to MSB. The pulse train is repeated three times. An example pulse train is shown in Figure 6-10 using a 60 MHz PS_CLK frequency. The timing will scale linearly with the PS_CLK frequency.

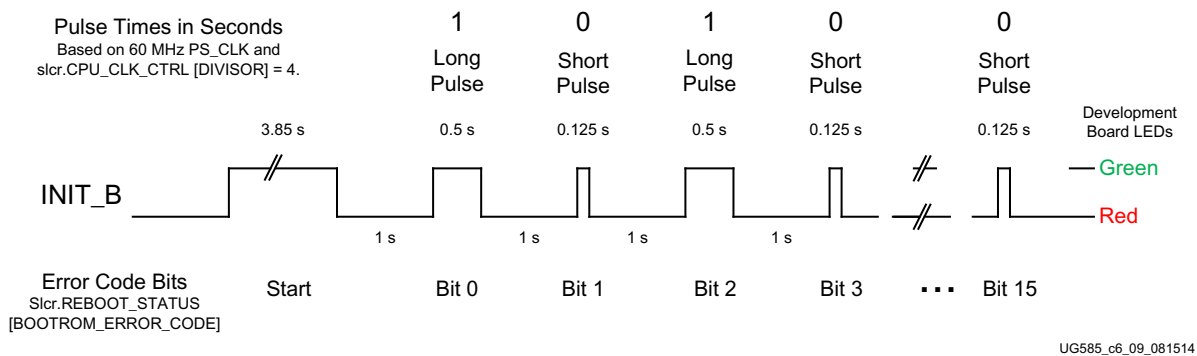

Figure 6-10: Error Code INIT_B Bit Waveform Example

Note: This waveform is based on the development board and the INIT_B polarity signal is inverted.

Non-secure boot failures result in the BootROM disabling access to the AES unit, clearing the PL, and enabling JTAG. The slcr.REBOOT_STATUS register can be read to determine the source of the boot failure.

Error Code Numbers

The error codes listed in [Table 6-20](#) describe the functionality of production devices. Other error code numbers might be generated by the BootROM, but are unlikely. If an error code occurs that is not listed in [Table 6-20](#) for production parts, contact Xilinx.

Lockdown Types

The Lockdown Type column includes information based on the type of reset that started the BootROM execution.

- POR reset (P)
- Non-POR reset (NP)

The type of lockdown indicated in [Table 6-20](#) includes the following notations:

- **Non-secure:** A non-secure lockdown occurs (system can be accessed by JTAG).
- **Header:** The lockdown type is defined by the Encryption Status parameter in the header.
- **Secure:** Always a secure lockdown (the system becomes inaccessible).
- **Previous:** Applies only after a non-POR reset. If the previous boot mode was secure, then this subsequent lockdown is secure. If the previous boot was non-secure, then this subsequent lockdown is non-secure.

Table 6-20: BootROM Error Codes

| Error Code | Lockdown Type ⁽¹⁾ | Description | Solution |
|------------|---------------------------------|--|---|
| 0x0002 | P: Non-secure NP: Non-secure | The system successfully booted in JTAG mode. | <ul style="list-style-type: none"> • Use the JTAG interface to the DAP and TAP controllers. |
| 0x2000 | P: Non-secure NP: Previous | Quad-SPI boot mode. The BootROM detected a x8 parallel device configuration using x1 mode, but then failed to read the expected header parameters using x8 mode. The BootROM continues with header search using x8 mode, but it was unable to find the Width Detection word using header search within the image search range. | <ul style="list-style-type: none"> • Check that the Quad-SPI device is properly connected to the QSPI MIO pins. • Be sure that the Width Detection word is set equal to the data pattern 0xAA995566 and that the Image Identification word has 0x584C4E58, 'XLNX' • Ensure that the device content is not blank In single device applications. |
| 0x2001 | P: Non-secure NP: Previous | NAND boot mode. The BootROM could not determine the ECC mode for the device. | <ul style="list-style-type: none"> • Check that the NAND device is on the vendor approved list, refer to (Xilinx AR# 50991). |

Table 6-20: BootROM Error Codes (Cont'd)

| Error Code | Lockdown Type ⁽¹⁾ | Description | Solution |
|------------|-------------------------------|---|---|
| 0x200A | P: Non-secure NP: Previous | SD card boot mode. The BootROM could not find the boot image at the root of the SD card; only a single boot image is supported for this boot mode. If the SD card was accessed by the FSBL/User code and then a system reset occurs without resetting the SD card, then the SD card might be left in 4-byte addressing mode. | <ul style="list-style-type: none"> • Check that there is a valid BootROM Header in the root directory of the SD card named BOOT.BIN. • Make sure the SD interface is operating reliably; for example using XMD or other debug tool to access it. • Make sure the SD card is in 3-byte addressing mode. • Check the mode pin settings. |
| 0x200B | P: Non-secure NP: Previous | NOR boot mode. The BootROM could not find a valid boot image in the NOR device after searching. | <ul style="list-style-type: none"> • Check that there is a valid BootROM Header within the search range, refer to the BootROM Header Search and Multiboot sections. |
| 0x200C | P: Non-secure NP: Previous | Quad-SPI boot mode. The BootROM is unable to find a valid header within the image search range. | <ul style="list-style-type: none"> • Check that there is a valid image written within the boot partition address search space for the device, refer to the BootROM Header Search and Multiboot sections. |
| 0x200D | P: Non-secure NP: Previous | NAND boot mode. The BootROM is unable to find a valid header within the image search range. | <ul style="list-style-type: none"> • Check that there is a valid image written within the boot partition address search space for the device, refer to the BootROM Header Search and Multiboot sections. |
| 0x200E | P: Header NP: Previous | An address in the Register Initialization field of the BootROM Header is out of the accessible range. | <ul style="list-style-type: none"> • Check that all addresses are within the range based on boot mode, refer to the Register Initialization address range table. |
| 0x200F | P: Secure NP: Secure | Secure boot mode. The Start of Execution word does not equal 0. | <ul style="list-style-type: none"> • The Start of Execution word must be equal to 0 in secure mode (boot from OCM). |
| 0x2011 | P: Header NP: Previous | NAND boot mode. Length of Image parameter is = 0. The execute-in-place mode is not supported in the NAND boot mode. | <ul style="list-style-type: none"> • Set the Length of Image parameter to the length of the boot image. Must fit into the 192 KB of available OCM memory. |
| 0x2012 | P: Header NP: Previous | SD card boot mode. Length of Image parameter is = 0. The execute-in-place mode is not supported in the SD card boot mode. | <ul style="list-style-type: none"> • Set the Length of Image parameter to the length of the boot image. Must fit into the 192 KB of available OCM memory. |
| 0x2019 | P: Secure NP: Secure | The encryption and eFuse combinations are not valid, refer to Table 6-7 . | <ul style="list-style-type: none"> • Make sure the Encryption Status parameter and the eFuse states are consistent. |
| 0x201A | P: Secure NP: Secure | Security Violation was detected. The system tried to transition from a secure operating mode to a non-secure boot mode without using POR. | <ul style="list-style-type: none"> • Assert the POR reset to boot in non-secure mode when the system was previously booted in secure mode. |

Table 6-20: BootROM Error Codes (Cont'd)

| Error Code | Lockdown Type ⁽¹⁾ | Description | Solution |
|------------|-------------------------------|---|--|
| 0x2023 | P: Non-secure NP: Previous | There is a mismatch between the value in the Header Checksum word and the calculated checksum for the header, or the Image Identification word in the BootROM Header does not contain 0x584C4E58, 'XLNX'. | <ul style="list-style-type: none"> Verify that the Header Checksum is correct. Make sure the Image Identification word has 0x584C4E58. Verify that the boot device can be accessed reliably using the JTAG boot mode. |
| 0x2024 | P: Header NP: Previous | The Image Identification word in the BootROM Header does not contain 0x584C4E58, 'XLNX'. | <ul style="list-style-type: none"> Make sure the Image Identification word equals 0x584C4E58. Verify that the boot device can be accessed reliably using the JTAG boot mode. |
| 0x2100 | P: Non-secure NP: Previous | The Image Identification word in the BootROM Header does not equal 0x584C4E58, 'XLNX'. | <ul style="list-style-type: none"> Make sure the Image Identification word has 0x584C4E58. Verify that the boot device can be accessed reliably. Boot in JTAG mode and test, if necessary. |
| 0x2101 | P: Non-secure NP: Previous | BootROM Header checksum fails. | <ul style="list-style-type: none"> Verify that the Header Checksum is correct. Verify that the boot device can be accessed reliably using the JTAG boot mode. |
| 0x2102 | P: Non-secure NP: Previous | The address value in the Source Offset word points to a location within the BootROM Header instead of where the image is actually located. | <ul style="list-style-type: none"> Check the address value in the Source Offset word. |
| 0x2103 | P: Non-secure NP: Previous | The address value in the Source Offset word is not aligned to a 64B boundary. | <ul style="list-style-type: none"> Align the address in the Source Offset word to a 64-byte boundary. |
| 0x2104 | P: Non-secure NP: Previous | Non-secure and execute from OCM mode. This error occurs if the image destination address crosses the 192 KB boundary (i.e., 0x070000). | <ul style="list-style-type: none"> Reduce the size of the initial FSBL/User code that is loaded into the OCM. |
| 0x2105 | P: Non-secure NP: Previous | Non-secure and execute from OCM mode. This error occurs if the image destination address is less than 0x00040000 if the image length is not equal to 0. | <ul style="list-style-type: none"> Execute the image at 0x00040000. |
| 0x2106 | P: Non-secure NP: Previous | Non-secure and execute from OCM mode. The Length of Image parameter exceeds the 192 KB limit of the OCM for the initial FSBL/User code. | <ul style="list-style-type: none"> Reduce the size of the initial FSBL/User code that is loaded into the OCM. |
| 0x2108 | P: Non-secure NP: Previous | Non-secure and execute from OCM mode. The Start of Execution parameter is greater than 192 KB (0x03 0000). | <ul style="list-style-type: none"> The Start of Execution value must be within the OCM. |
| 0x2109 | P: Non-secure NP: Previous | The Reserved parameter (0x038) is not set = 0. | <ul style="list-style-type: none"> Set the reserved parameter at 0x038 to 0. |

Table 6-20: BootROM Error Codes (Cont'd)

| Error Code | Lockdown Type ⁽¹⁾ | Description | Solution |
|------------|-------------------------------|---|--|
| 0x210A | P: Non-secure NP: Previous | Applies to secure boot mode. The Length of Image word in the header is set to 0 (execute-in-place). | <ul style="list-style-type: none"> Execute-in-place is not supported in secure mode. Either specify non-secure mode, or change the Length of Image word to match the image length after decryption. |
| 0x210B | P: Secure NP: Previous | Secure mode. HMAC error occurred. | <ul style="list-style-type: none"> Verify that the key and key source are the same for encryption and decryption. |
| 0x210D | P: Header NP: Previous | This error occurs if the image length is not equal to 0 and the length is greater than 192 KB. | <ul style="list-style-type: none"> Reduce the size of the initial FSBL/User code that is loaded into the OCM. |
| 0x210E | P: Header NP: Previous | The Length of Image parameter is set to 0 indicating an execute-in-place boot, but the selected boot mode does not support execute-in-place. | <ul style="list-style-type: none"> Check the boot mode settings. NAND and SD card do not support execute-in-place. |
| 0x210F | P: Header NP: Previous | BootROM Header checksum failed before processing the Register Initialization words. | <ul style="list-style-type: none"> Verify that the Header Checksum is correct. Verify that the boot device can be accessed reliably using the JTAG boot mode. |
| 0x2110 | P: Header NP: Previous | The Image Identification word in the BootROM Header does not contain 0x584C4E58, 'XLNX'. | <ul style="list-style-type: none"> Make sure the Image Identification word has 0x584C4E58. Verify that the boot device can be accessed reliably by using the JTAG boot mode to download test software. |
| 0x2111 | P: Header NP: Previous | One or more address/write-data pairs in the Register Initialization section of the BootROM Header contains an address outside of the allowed range. | <ul style="list-style-type: none"> Make sure the addresses in the Register Initialization section are within the ranges defined in the TRM table 6-13 Boot Image Address-Data Write Address Ranges. |
| 0x2200 | P: Secure NP: Previous | Secure boot mode. The image size after decryption does not fit into the 192 KB of available OCM memory. | <ul style="list-style-type: none"> Reduce the size of the initial FSBL/User code that is loaded into the OCM. |

Notes:

- There are two reset types, POR (P) and non-POR (NP). Refer to the text preceding the table for an explanation of the lockdown type column.

6.3.13 Post BootROM State

The state of the PS after the BootROM executes depends on these conditions:

- Decryption Status parameter.
- Boot strap mode pins.
- Actions of the BootROM based on system discovery.

The mode pins impact which MIO are enabled and what I/O standard they are set to after exiting the BootROM. Additionally, the mode setting impacts the boot peripheral settings. For example, if Quad-SPI is the selected boot source, the needed MIO is enabled and the Quad-SPI controller is set

with the necessary settings to read from flash. The modified values for each boot source are documented in the associated boot devices section.

APU and OCM State after BootROM

The general processor state upon BootROM exit is as follows:

- MMU, Icache, Dcache, L2 cache are all disabled.
- Both processors are in the supervisor state.
- ROM code is inaccessible.
- 192 KB of OCM memory is accessible starting at address `0x0000_0000` while the upper 64 KB of the OCM is accessible starting at address `0xFFFF_0000`.
- CPU 0 branches into the stage 1 boot image if no failure takes place.
- CPU 1 is in a WFE state while executing code located at address `0xFFFF_FE00` to `0xFFFF_FFF0`.

Memory Map During BootROM Execution

The system memory map during BootROM execution places 192 KB of OCM at the bottom of memory and 64 KB at the top as shown in Figure 6-11. The 64 KB memory block is used by the BootROM to store the BootROM Header and program variables. After the BootROM is finished, the 64 KB OCM memory block is freed-up for the FSBL to use.

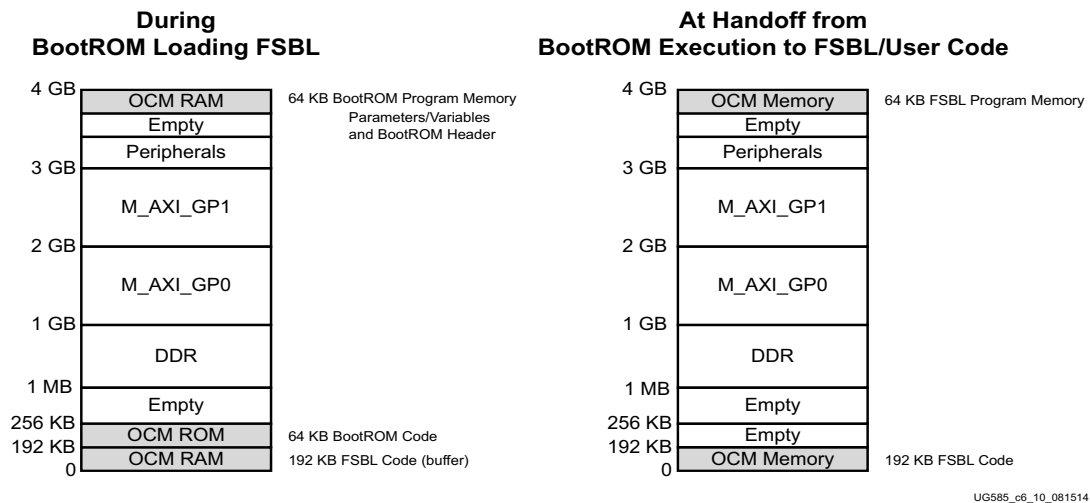

Figure 6-11: System Memory Map During BootROM Execution

Post BootROM Security

If secure mode is enabled, the AES unit is accessible post BootROM. In non-secure mode, the AES unit is not accessible.

The BootROM locks several bits in the DevC module prior to exiting to ensure security. The bits the BootROM locks are listed in Table 6-21; where 1 = locked. The Lock bits are used to disable writes to bits in the devcfg.CTRL register. Once a lock bit is set, it cannot be cleared except by a POR reset. The BootROM will lock some of these bits before turning PS control over to the FSPL/User code.

Table 6-21: devcfg.LOCK Register

| Bit Position | Bit Name | BootROM Secure Boot Lock Status | BootROM Non-Secure Boot Lock Status |
|--------------|---------------|---------------------------------|-------------------------------------|
| 31:5 | Reserved | ~ | ~ |
| 4 | AES_FUSE_LOCK | 1 | 0 |
| 3 | AES_EN_LOCK | 0 | 1 |
| 2 | SEU_LOCK | 0 | 0 |
| 1 | SEC_LOCK | 1 | 0 |
| 0 | DBG_LOCK | 0 | 0 |

Post BootROM Debug

In the event of a failure while booting non-secure the BootROM enables JTAG access so that the REBOOT_STATUS and other registers can be read using the DAP controller. A debugging tool like XMD has full access to the processor when JTAG is enabled and includes the DAP controller in the chain.

If a failure occurs while booting in secure mode, the BootROM disables the AES unit, clears the OCM, clears the PL, and halts the processor. JTAG is not enabled, consequently, the REBOOT_STATUS value is not available to be read. Instead, the 16-bit error code is shown by toggling the INIT_B pin.

6.3.14 Registers Modified by the BootROM – Examples

Examples of registers modified by the BootROM are listed in Table 6-22. When multiple register values appear in the table, this indicates that the value depends on other factors. Refer to the footnotes and text for more information. These are values that have been observed when the BootROM transfers CPU control from the FSBL/User code.

These values were obtained from test run on the ZC702 board with the 7z020 production device and the ZC706 board with the 7z035/7z045 production devices.

Table 6-22: BootROM Modified Registers

| Address | Register Name ⁽¹⁾ | Reset Value | JTAG Boot | Quad-SPI Boot | SD Card Boot |
|-------------------------|------------------------------|-------------|-------------|--------------------------|--------------------------|
| devcfg Registers | | | | | |
| 0xF800_7000 | CTRL | 0x0C006000 | 0x4E00E07F | 0x4C00E07F 0x4E80EE80 | 0x4E00E07F 0x4E80EE80 |
| 0xF800_7004 | LOCK | 0x00000000 | 0x0000001A | 0x0000001A 0x00000012 | 0x0000001A 0x00000012 |
| 0xF800_7008 | CFG | 0x00000508 | reset value | reset value | reset value |

Table 6-22: BootROM Modified Registers (Cont'd)

| Address | Register Name ⁽¹⁾ | Reset Value | JTAG Boot | Quad-SPI Boot | SD Card Boot |
|--------------------------|------------------------------|-------------|---|--|--------------------------|
| 0xF800_700C | INT_STS | 0x00000000 | 0xF8020006 0xA802000A 0xA802000B | 0xA803000A 0xA803100A 0xA883100A | 0xA802000A 0xA803000A |
| 0xF800_7014 | STATUS | 0x40000820 | 0x40000F30 0x40000A30 | 0x40000A30 | 0x40000A30 |
| 0xF800_7028 | ROM_SHADOW | 0x00000000 | 0xFFFFFFFF | | |
| 0xF800_7034 | UNLOCK | 0x00000000 | 0x757BDF0D | 0x757BDF0D | 0x757BDF0D |
| 0xF800_7080 | MCTRL | x | 0x10800000 0x30800100 | 0x30800100 | 0x30800100 |
| I2cache Registers | | | | | |
| 0xF8F0_2104 | reg1_aux_control | 0x02050000 | 0x02060000 | | |
| 0xF8F0_2F40 | reg15_debug_ctrl | 0x00000000 | 0x00000004 | 0x00000004 0x00000000 | 0x00000004 0x00000000 |
| mpcore Registers | | | | | |
| 0xF8F0_0040 | Filtering_Start_Addr | 0x00100000 | reset value | reset value | reset value |
| 0xF8F0_0044 | Filtering_End_Addr | 0x00000000 | 0xFFE00000 | 0xFFE00000 | 0xFFE00000 |
| 0xF8F0_0108 | ICCBPR | 0x00000002 | reset value | | |
| 0xF8F0_0200 | Global_Timer_Counter_0 | 0x00000000 | The value depends on when the register is read. | | |
| 0xF8F0_0204 | Global_Timer_Counter_1 | 0x00000000 | The value depends on when the register is read. | | |
| 0xF8F0_0208 | Global_Timer_Control | 0x00000000 | 0x00000001 | | 0x00000001 |
| slcr Registers | | | | | |
| 0xF800_0258 | REBOOT_STATUS ⁽²⁾ | 0x00400000 | 0x00400002 | 0x00400000 0x00600000 | 0x00400000 0x00600000 |
| 0xF800_0910 | OCM_CFG | 0x00000000 | 0x00000018 | 0x00000018 | 0x00000018 |
| 0xF800_0A1C | Reserved | 0x00010101 | 0x00010101 | 0x00020202 | 0x00020202 |
| 0xF800_0B04 | GIOB_CFG_CMOS18 | 0x00000000 | 0x0C301166 | 0x0C301166 | 0x0C301166 |
| 0xF800_0B08 | GIOB_CFG_CMOS25 | 0x00000000 | 0x0C301100 | 0x0C301100 | 0x0C301100 |
| 0xF800_0B0C | GIOB_CFG_CMOS33 | 0x00000000 | 0x0C301166 | 0x0C301166 | 0x0C301166 |
| 0xF800_0B14 | GIOB_CFG_HSTL | 0x00000000 | 0x0C750077 | 0x0C750077 | 0x0C750077 |
| 0xF800_0B70 | DDRIOB_DCI_CTRL | 0x00000020 | reset value | 0x00000823 | 0x00000823 |
| uart1 Registers | | | | | |
| 0xE000_1000 | Control_reg0 | 0x00000128 | 0x00000114 | 0x00000114 | 0x00000114 |
| 0xE000_1004 | mode_reg0 | 0x00000000 | 0x00000020 | 0x00000020 | 0x00000020 |
| 0xE000_1014 | Chnl_int_sts_reg0 | 0x00000200 | reset value | 0x00000E10 | 0x00000E10 |
| 0xE000_1018 | Baud_rate_gen_reg0 | 0x0000028B | reset value | 0x0000003E | 0x0000003E |
| 0xE000_1028 | Modem_sts_reg0 | x | 0x000000FB | 0x000000FB | 0x000000FB |
| 0xE000_102C | Channel_sts_reg0 | 0x00000000 | reset value | 0x00006812 | 0x00006812 |

Table 6-22: BootROM Modified Registers (Cont'd)

| Address | Register Name ⁽¹⁾ | Reset Value | JTAG Boot | Quad-SPI Boot | SD Card Boot |
|-------------|------------------------------|-------------|-------------|---------------|--------------|
| 0xE000_1034 | Baud_rate_divider | 0x0000000F | reset value | 0x00000006 | 0x00000006 |

Notes:

1. Some register names are truncated or abbreviated to keep them short in this table.
2. In the REBOOT_STATUS register, a 4 means a POR reset and a 6 means an SRST (non-POR) reset.

6.4 Device Boot and PL Configuration

The Zynq device is a complex system that can be tightly controlled (secured) by the PS boot process or be open and accessible in a friendly and/or development environment. The PS-centric control of the Zynq device assumes a secure environment after a POR reset until the Encryption Status parameter in the BootROM Header is read or until JTAG boot mode is detected. When security discrepancies are detected, the BootROM executes a system lockdown.

Basic Boot Sequence

There are many different boot sequences. The common thread is that after a system reset (POR and non-POR), the BootROM executes first to configure and control the system. After a POR reset, there are a few hardware activities that are performed before the BootROM executes. These hardware activities are described in [Figure 6-1, page 151](#). After the BootROM executes, the FSBL/User code takes control of the PS and is able to further configure the device, including the PL.

1. **Power-up and Reset Operations.** See section [6.2 Device Start-up](#).
2. **BootROM Execution.** See section [6.3.3 BootROM Performance](#).
3. **FSBL/User Code to Configure PS.** Refer to [UG821, Zynq-7000 SoC Software Developers Guide](#) for information on creating FSBL/User code.
4. **FSBL/User Code to Initialize and Configure PL.** The controls are shown in [Figure 6-12](#). Refer to [UG821, Zynq-7000 SoC Software Developers Guide](#) for information on creating FSBL/User code.

In a development environment (non-secure), the user can access the Xilinx TAP controller in the PL and the Arm DAP controller in the PS. This section focusses on the boot process from the PS software perspective with a section on configuring the PL using JTAG.

Chapter Sections

This chapter section includes the following subsections to explain various aspects of device configuration:

- [6.4.1 PL Control via PS Software](#)
- [6.4.2 Boot Sequence Examples](#)
- [6.4.3 PCAP Bridge to PL](#)
- [6.4.4 PCAP Datapath Configurations](#)
- [6.4.5 PL Control via User-JTAG](#)

6.4.1 PL Control via PS Software

The PL is controlled by PS software (Figure 6-12) through the PCAP bridge or using external pins and the JTAG interface associated with the PL (Figure 6-20, page 220).

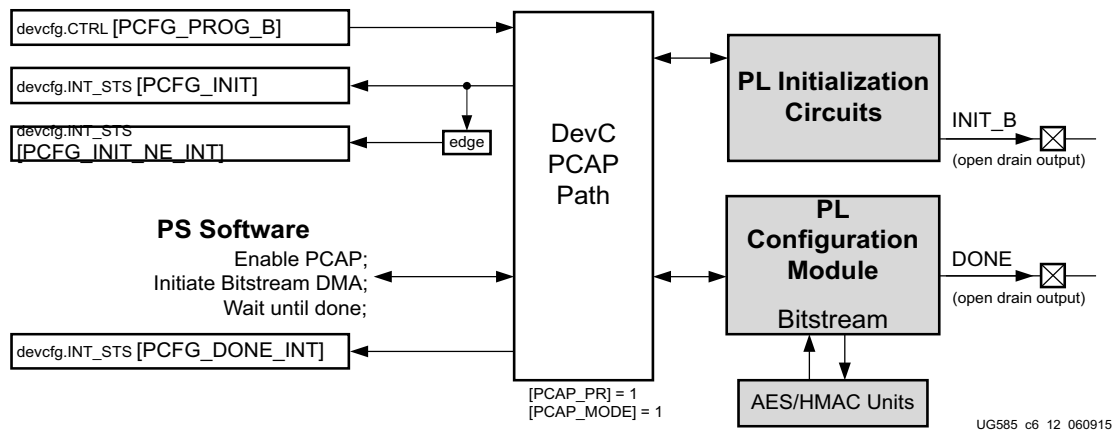

Figure 6-12: PCAP Path for PL Initialization and Configuration

PL Initialization via PS Software

At any time, the devcfg.CTRL [PCFG_PROG_B] bit can be used to issue a global reset to the PL. If this bit is set Low, the PL begins its initialization process and the devcfg.STATUS [PCFG_INIT] bit is held Low until the [PCFG_PROG_B] bit is set High by the hardware. The programming sequence to initialize the PL include these steps:

1. Set [PCFG_PROG_B] signal to High
2. Set [PCFG_PROG_B] signal to Low
3. Poll the [PCFG_INIT] status for Reset
4. Set [PCFG_PROG_B] signal to High
5. Poll the [PCFG_INIT] status for Set

PL Configuration via PS Software

PL configuration and reconfiguration support are illustrated with an example that simplifies software knowledge of state. The sequence assumes the PL is uninitialized and system state is unknown. Users can build on these steps.

To configure the PL, enable the interface and select the PCAP programming path. Clear interrupts, initialize the PL, and disable the internal DevC loopback function. The new bitstream is transferred to the PL using the DevC DMA unit. Both the PS and PL must be powered on to configure or reconfigure the PL.

6.4.2 Boot Sequence Examples

There are a multitude of variables in the boot process of the PS and PL. An entire boot sequence can include PS and PL hardware operations, BootROM execution, FSBL/User code execution and starting the operating system software.

When considering a secure environment, there are multiple resources to reference. At the low-level, refer to this chapter and [Chapter 32, Device Secure Boot](#). As the system transitions to the FSBL and the Operating System, refer to [UG821, Zynq-7000 SoC Software Developers Guide](#).

The fastest boot times are obtained in PS-only non-secure mode. For time critical applications, there are several areas to consider. Major time sinks for time critical applications include the bandwidth of the boot device, decryption, power supply ramp time, and the ROM code CRC check.



IMPORTANT: *The time it takes for each boot process to complete can be difficult to calculate because of all the variables involved. The values provided here are meant as a guide, not a definitive answer. If you have any questions, please contact your Xilinx FAE Sales Engineer.*

This section starts by defining a few different boot sequences that are controlled by PS software (BootROM or FSBL/User code).

Example Sequences

- Seq 1: PS Non-secure Bring-up (no PL power)
- Seq 2: PS Secure Bring-up with PL Configuration
- Seq 3: PL Bring-up by FSBL/User Code

PS Non-secure Bring-up Example

The PS and PL can be brought up together in a secure or non-secure mode. The simultaneous bring-up of the PS and PL is shown in [Figure 6-12](#). Also refer to [Figure 6-4, page 165](#) for details on power, reset, and clock interactions and timing examples. The PS non-secure bring-up using a flash device without JTAG illustrates a simple example with minimal resources. The example is shown in [Figure 6-14](#). When the PL is needed later in the system operation, its bring-up is explained in the PL Bring-up by FSBL/User Code example.

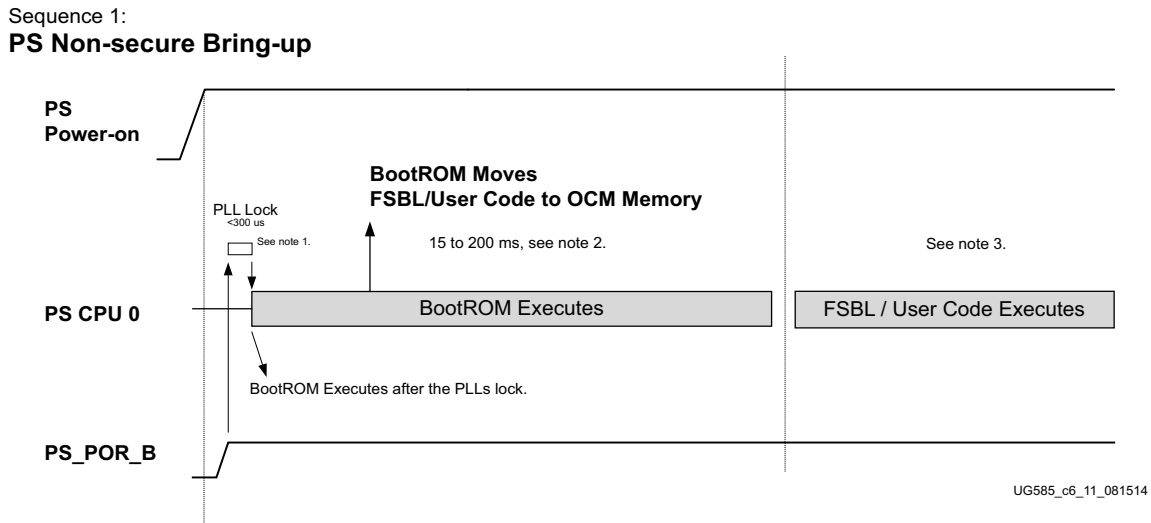

- 1) **PLL lock time.** The PLL lock time is discussed in section [6.3.3 BootROM Performance](#).
- 2) **BootROM Execution.** This time is highly dependent on the bandwidth of the flash device interface. For BootROM execution, refer to section [6.3.3 BootROM Performance](#).
- 3) **FSBL/User Code Execution.** The execution time for the FSBL/User code is beyond the scope of UG585, please refer to [UG821](#), *Zynq-7000 SoC Software Developers Guide*.

Figure 6-14: PS Non-secure Bring-up Example

PS Bring-up with PL Configuration Example

The PS and PL can be brought up together in a secure or non-secure mode. The simultaneous bring-up of the PS and PL is shown in [Figure 6-15](#). Also refer to [Figure 6-4](#), page 165 for details on power, reset, and clock interactions and timing examples.

In this example, the bring-up process boots from a flash memory device. The BootROM supports both secure (encrypted images) and non-secure boot modes (no encryption). This bring-up sequence is summarized in these steps below. The non-secure boot without the PL is illustrated in [Figure 6-14](#) and the secure boot mode with PL is illustrated in [Figure 6-15](#):

1. Power-supplies are stable, PS_CLK is stable. See section [6.2.3 Clocks and PLLs](#).
2. PS_POR_B reset deasserts; for **Secure** boot, the PL is powered-on with the PS and self initializes.
3. BootROM executes in CPU 0:
 - a. Reads slcr.BOOT_MODE register to determine boot device.
 - b. Reads BootROM Header to determine encryption status and image destination.
 - c. **Secure:** Ensures PL is powered on to begin FSBL/User code decryption.
4. BootROM prepares for the CPU to execute the FSBL/User code:
 - a. **Non-Secure:** BootROM loads the FSBL/User code into OCM (or prepares for execute-in-place) on Quad-SPI and NOR devices.

- b. **Secure:** BootROM programs the DevC DMA controller to transfer the encrypted FSBL/User code into the RxFIFO and send it to the AES and HMAC modules in the PL. The decrypted image accumulates in the Tx FIFO and is written into the OCM memory by the DMA controller.
- 5. BootROM is disabled and CPU control is transferred to the FSBL/User code.
 - a. **Non-Secure:** Code can be in OCM memory or executed directly from the boot device.
 - b. **Secure:** Code is executed from OCM memory.
- 6. The FSBL/User code loads PL bitstream. (Optional)
 - a. **Non-Secure:** The code loads the bitstream using the PCAP controller.
 - b. **Secure:** The code loads the encrypted bitstream through the PCAP interface to the AES/HMAC modules.

Sequence 2:

PS Bring-up with PL Configuration Option

NOTE: Figure not to scale.

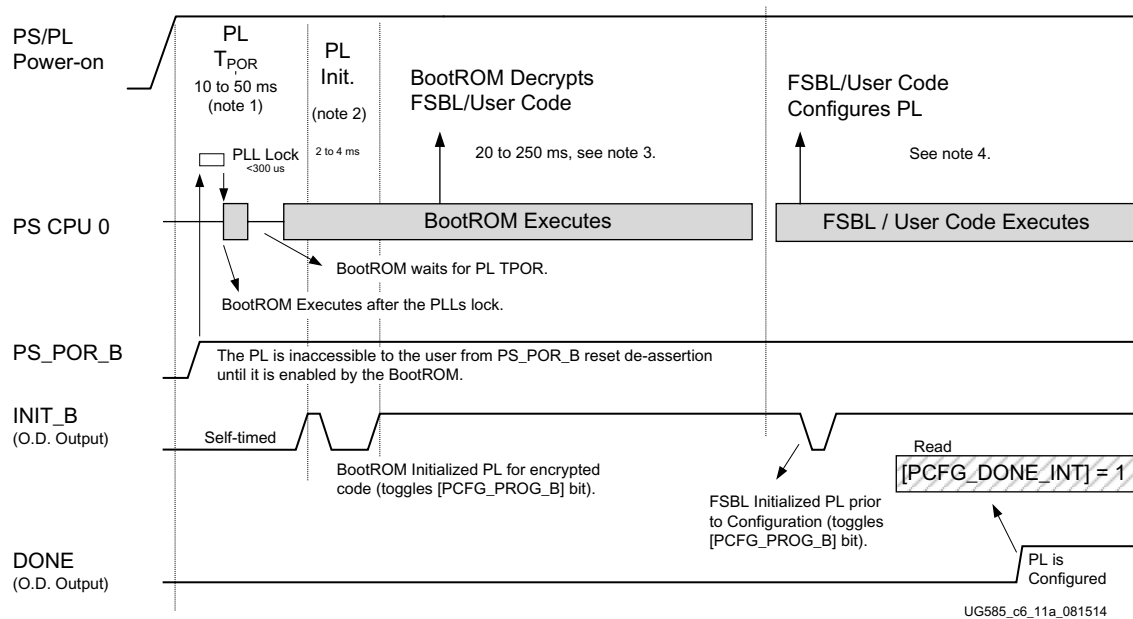

- 1) **PL T_{POR} and PLL Lock Time.** The T_{POR} time is dependent on the voltage ramp of the power supply and is defined in the data sheet. If the PL is already powered-up, then T_{POR} time = 0. The PLL Lock time is specified in the data sheet with the T_{LOCK_PSPLL} parameter. The PLL is locked before the BootROM starts to execute.
- 2) **PL Init Time.** This happens very quickly and is affected by the size of the PL.
- 3) **BootROM Decrypts FSBL/User Code.** The BootROM copies the encrypted boot image to OCM memory. The DevC DMA controller reads the image into its Rx FIFO, sends it through the AES or HMAC units, and then writes the image back to OCM memory. The time depends on many factors: type of Flash device interface, PS_CLK frequency and the image size. This time range is taken from [Table 6-8, page 181](#).
- 4) **FSBL/User Code Configures PL.** The PS software programs the DMA to read the bitstream and optionally decrypt it before going to the PL Configuration module. The time depends on many factors: type of Flash device interface, PS_CLK frequency, bitstream size, and if the bitstream is encrypted.
- 5) **Enable PL.** After the PL is configured, the [PCFG_DONE_INT] bit asserts and the user code enables the voltage level shifters. A power-up sequence example is shown in section [2.4 PS-PL Voltage Level Shifter Enables](#).

Figure 6-15: PS Bring-up with PL Configuration Option Example

PL Bring-up by FSBL/User Code Example

The PL may not be initially initialized and configured after a device boot. The PL may also be shut down during system operation. This example illustrates how the PL can be configured from scratch under the control the FSBL/User code.

Sequence 3:
PL Bring-up by FSBL/User Code

NOTE: Figure not to scale.

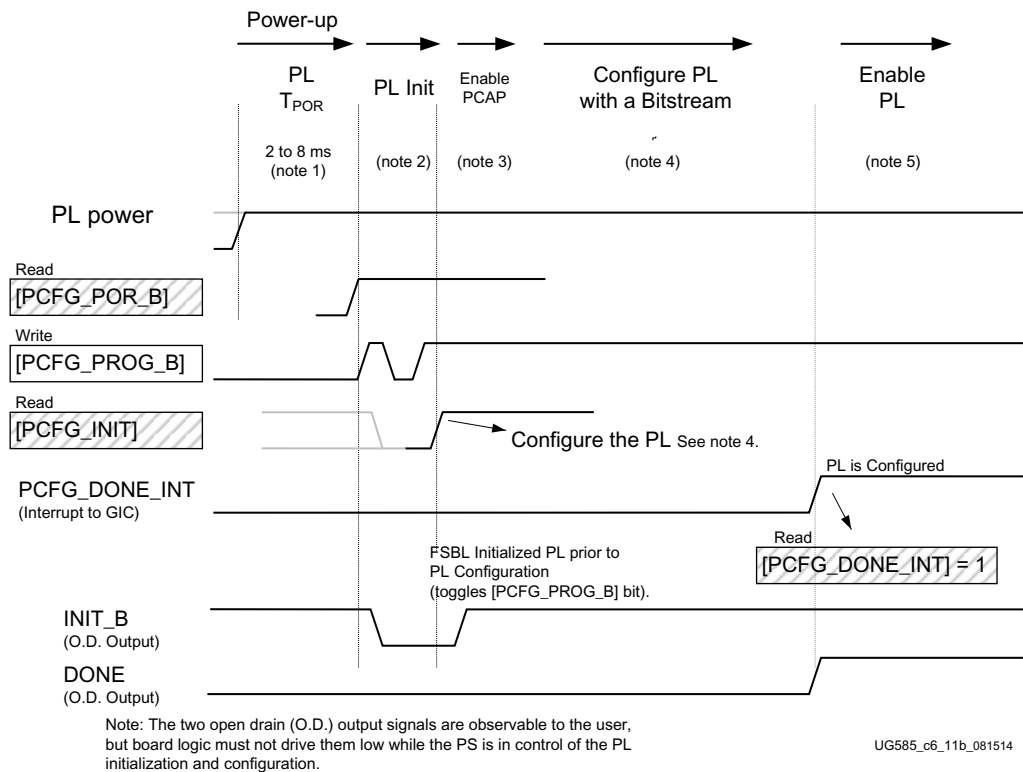

- 1) **PL T_{POR} Time.** The T_{POR} time is dependent on the voltage ramp of the power supply. The allowed PL voltage ramp time and T_{POR} times are specified in the data sheet. If the PL is already powered-up, then T_{POR} time = 0.
- 2) **PL Init Time.** The PL initialization time.
- 3) **Enable PCAP.** The PCAP control is described in section 6.4.3 PCAP Bridge to PL.
- 4) **Configure the PL.** Loading the PL Bitstream depends on many factors, see Table 6-25, page 223.
- 5) **Enabled.** The PL is in user mode when the [PCFG_DONE_INT] bit reads a 1. There is an example PL enable sequence in section 2.4 PS-PL Voltage Level Shifter Enables.

Figure 6-16: PL Bring-up by FSBL/User Code Example

Configure the PL via PCAP Bridge Example

1. **Enable the PCAP bridge and select PCAP for reconfiguration.** Write ones to devcfg.CTRL [PCAP_MODE] and [PCAP_PR] bits.
2. **Clear the Interrupts.** Write all ones to the devcfg.INT_STS register.
3. **(Optional) Initialize the PL** (clears previous configuration):
 - a. Write 1 to [PCFG_PROG_B] bit.

- b. Write 0 to [PCFG_PROG_B] bit.
- c. Wait for devcfg.STATUS [PCFG_INIT] bit = 0.
- d. Write 1 to [PCFG_PROG_B] bit.
- e. Clear the PL configuration done interrupt: Write 1 to devcfg.INT_STS [PCFG_DONE_INT].
4. Ensure that the PL is ready for programming: Wait for the devcfg.STATUS [PCFG_INIT] bit to = 1.
5. **Check that there is room in the Command Queue.** Verify devcfg.STATUS [DMA_CMD_Q_F] = 0. Note, this step is not necessary if the PL is in the initialized state.
6. **Disable the PCAP loopback.** Write a zero (0) to the devcfg.MCTRL [INT_PCAP_LPBK] bit.
7. Program the PCAP_2x clock divider.
 - a. **Secure Mode:** Set devcfg.CTRL [QUARTER_PCAP_RATE_EN] bit = 1.
 - b. **Non-secure Mode:** Clear [QUARTER_PCAP_RATE_EN] bit = 0.
8. Queue-up a DMA transfer using the devcfg DMA registers:
 - a. Source Address: Location of new PL bitstream.
 - b. Destination Address: 0xFFFF_FFFF.
 - c. Source Length: Total number of 32-bit words in the new PL bitstream.
 - d. Destination Length: Total number of 32-bit words in the new PL bitstream. Write to the devcfg.DMA_DEST_LEN register last to move the value of all four registers into the Command Queue.
9. **Wait for the DMA transfer to be done.** Wait for the devcfg.INT_STS [DMA_DONE_INT] bit = 1.
10. **Check for errors.** Interrogate bits in the devcfg.INI_STS register: AXI_WERR_INT, AXI_RTO_INT, AXI_RERR_INT, RX_FIFO_OV_INT, DMA_CMD_ERR_INT, DMA_Q_OV_INT, P2D_LEN_ERR_INT, PCFG_HMAC_ERR_INT.
11. **Make sure the PL configuration is done.** Poll for [PCFG_DONE_INT] bit = 1.

If the PL is cleared using devcfg.CTRL [PCFG_PROG_B], then the devcfg.INT_STS [PCFG_DONE_INT] bit is set when the PL is ready for reconfiguration. If the PL is cleared by asserting the PROGRAM_B signal pin, then the DONE signal is asserted and the devcfg.INT_STS [D_P_DONE_INT] bit is set when the operation is completed.

6.4.3 PCAP Bridge to PL

The PCAP bridge (also known as the AXI-PCAP bridge or PCAP interface) can be used to configure the PL with a bitstream, decrypt boot images and bitstreams, and authenticate files. The bridge has these operating modes:

- PCAP PL Bitstream Configuration Programming (encrypted and non-encrypted)
- PCAP PL Bitstream Readback
- PCAP Data Stream Decryption/Authentication
- Loopback for DMA transfers of Boot Images by BootROM and FSBL

The bridge's DMA controller moves boot images between the FIFOs and a memory device; typically the OCM memory, the DDR memory, or one of the linearly addressable flash devices (Quad-SPI or

NOR). The DMA controller is register programmed and can generate PS interrupts. It is a master on the PS AXI interconnect. The bridge FIFOs normally interface with the PCAP configuration module to transfer boot images and bitstreams.

Note: The DevC DMA controller is specifically designed for tasks associated with boot operations. For general DMA needs, the DMA controller described in [Chapter 9, DMA Controller](#) must be used.

The bridge supports both concurrent (bidirectional) and non-concurrent (unidirectional) download and upload of boot images. Transmit and receive FIFOs buffer data between the PS AXI Interconnect and the PCAP interface. For PCAP data, the bridge converts 32-bit AXI formatted data to the 32-bit PCAP protocol and vice versa.

Non-secure bitstreams and boot images sent to the PCAP interface can be sent every PCAP clock cycle. Secure (encrypted) data is sent to the PCAP interface every four PCAP clock cycles.

The architecture of the PCAP bridge is shown in [Figure 6-17](#).

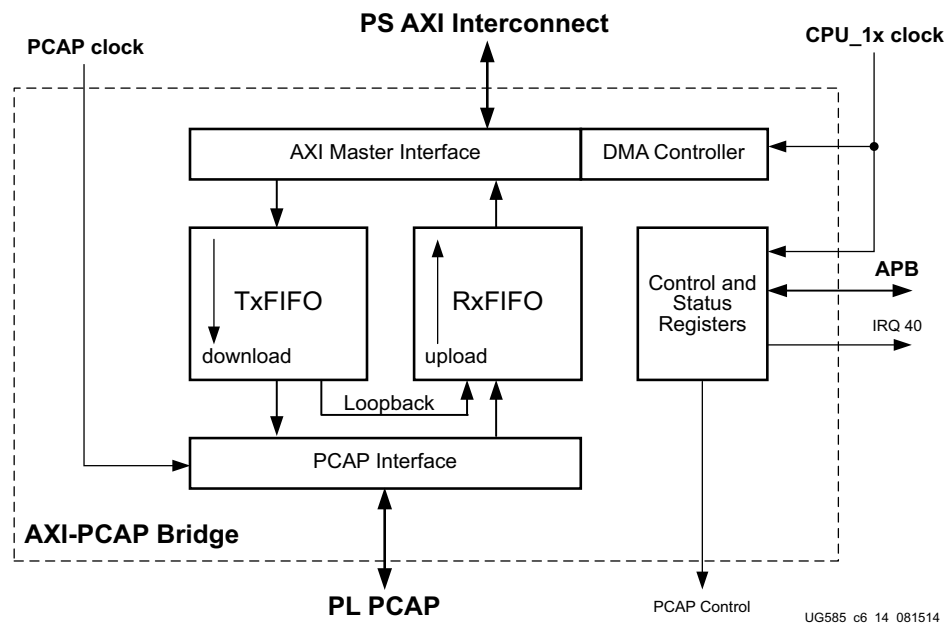

Figure 6-17: PCAP Bridge Architecture

The PL must be powered on to use the DevC module, including the PCAP bridge and PCAP configuration module. The PCAP interface is enabled by setting the devcfg.CTRL [PCAP_MODE] and [PCAP_PR] bits = 1 as illustrated in [Figure 6-2, page 158](#). If encrypted bitstreams or boot images are being sent, then the devcfg.CTRL [QUARTER_PCAP_RATE_EN] bit must be set = 1 to match the 32-bit PCAP interface to the 8-bit AES/HMAC unit interface.

To start a DMA transfer, these four DMA registers must be written in this order:

1. Source Address register, devcfg.DMA_SRC_ADDR
2. Destination Address register, devcfg.DMA_DST_ADDR
3. Source Length register, devcfg.DMA_SRC_LEN
4. Destination Length register, devcfg.DMA_DEST_LEN (triggers DMA transfer)

In all modes, the DMA transactions must be 64-byte aligned to prevent accidentally crossing a 4K byte boundary. The DMA status is tracked using the devcfg.INT_STS [DMA_DONE_INT] and [D_P_DONE_INT] bits. They can be monitored using either interrupts or a polling method.

6.4.4 PCAP Datapath Configurations

The PCAP bridge provides the FSBL/User code software with access to the PL configuration module and decryption unit. The configuration module processes the bitstream and loads the SRAM in the PL. The decryption unit is used to decrypt the bitstream and code files. The PL must be powered up to use the bridge.

There are four common datapaths used with the PCAP bridge. The paths are illustrated in [Figure 6-18](#) and [Figure 6-19](#).

- Non-secure bitstream (unencrypted)
- Secure bitstreams and software boot images (encrypted)
- PL bitstream readback (from PL)
- Loopback for boot image transfers

Non-Secure PL Bitstream

The non-encrypted bitstream is usually accessed by DMA from the DDR memory and directly into the PL configuration module. It bypasses the AES and HMAC units. This path can be used for configuration and reconfiguration of the PL.

Secure Bitstreams and Software Boot Images

The encrypted bitstream is accessed by DMA from the DDR memory to the AES and HMAC units in the PL. From the AES/HMAC units, the decrypted bitstream is routed directly to the PL configuration module. This path can be used for configuration and reconfiguration of the PL.

There is a separate datapath and FIFO for receive and transmit in the PCAP interface bridge. This path can be used by the FSBL/User code and operating system code.

To transfer boot images and bitstreams to the PL through the PCAP interface, the destination address must be `0xFFFF_FFFF`. Similarly, to read bitstreams from the PL through the PCAP interface, the source address must be `0xFFFF_FFFF`. Encrypted PS images must also be sent across the PCAP interface because the AES and HMAC units reside within the PL. In this case, the DMA source address could be an external memory interface and the destination address could be OCM memory.

Status Interrupts Bits

The DMA controller can trigger the DevC interrupt to the GIC interrupt controller upon completion of the PL configuration transfer. The interrupt can be triggered when the AXI side of the DMA transaction is complete (DMA_DONE_INT) or when both the AXI and PCAP transfers are complete (D_P_DONE_INT). The AXI interconnect completion interrupt allows the software that is controlling the DMA to perform scatter-gather type operations by issuing multiple DMA commands but holding off the last transfer interrupt until all of the PCAP transactions are done.

Setting the two LSBs of the source and destination address to 2'b01 indicates to the DevC DMA module the last DMA command of an overall transfer. The DMA controller uses this information to appropriately set the DMA done interrupt. For the last DMA command, the DMA done interrupt is triggered when both the AXI and PCAP interfaces are done. For all other DMA commands, the DMA done interrupt is set when the AXI transfers are done; however, there might still be on-going PCAP transfers. This distinction is made to allow overlapping AXI and PCAP transfers for all except the last DMA transfer.

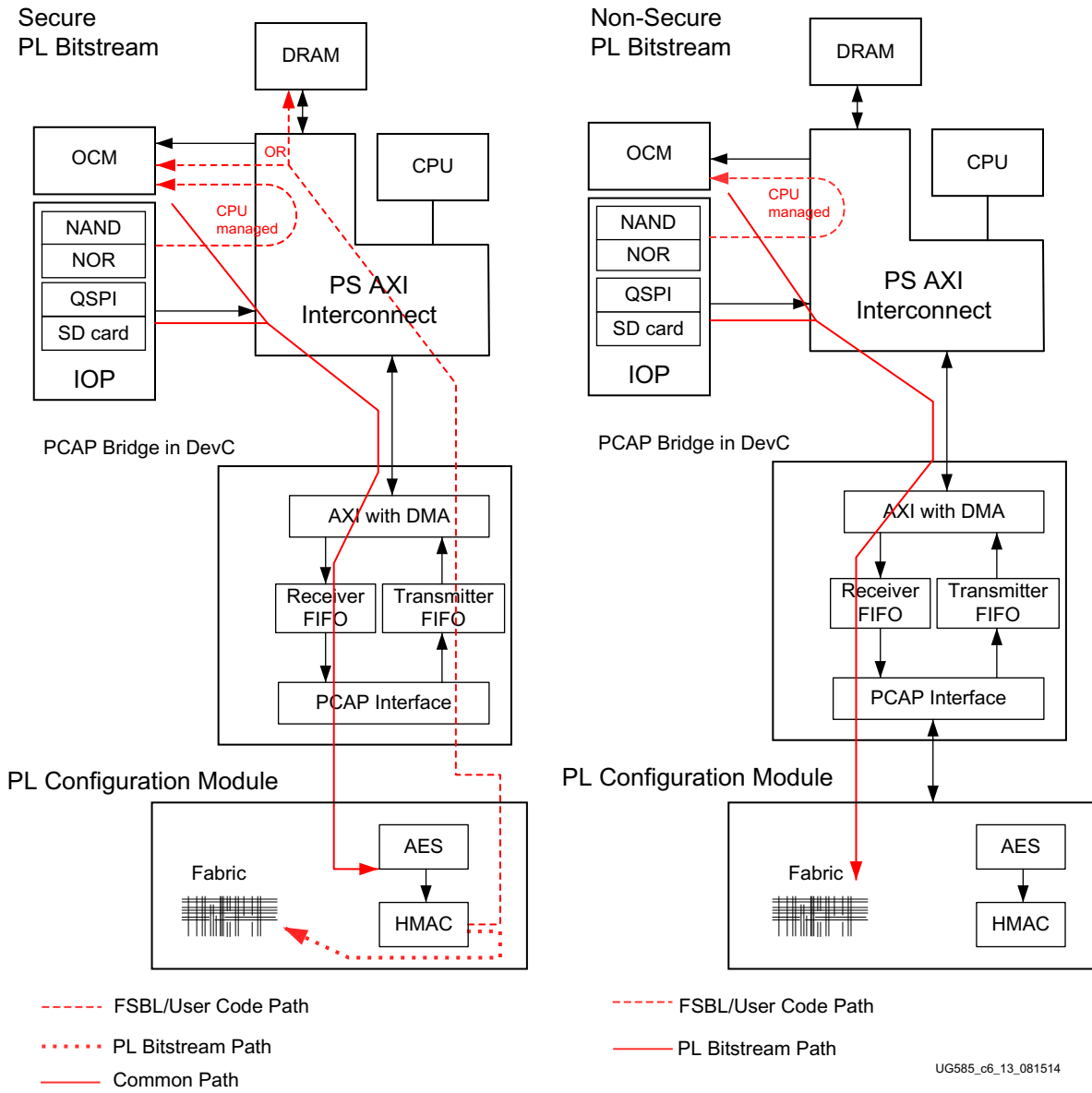

Figure 6-18: Non-Secure and Secure PL Bitstream Path Diagrams

PL Bitstream Readback

The PCAP interface can also be used to perform a PL bitstream readback. To perform a readback, the PS must be running software capable of generating the correct PL readback commands. Two DMA accesses are required to complete a PL configuration readback. The first access is used to issue the readback command to the PL configuration module. The second access is needed to read the PL bitstream from the PCAP. The smallest amount of bitstream data that can be read back from the PL is one configuration frame which contains 101 32-bit words. An example program sequence is shown below. The datapath is illustrated in [Figure 6-19](#).

Example: PL Bitstream Readback

This example shows the first DMA access for a PL bitstream readback:

1. DMA Source Address – location of PL readback command sequence.
2. DMA Destination Address – desired location to store readback bitstream, note that the OCM memory is not large enough to hold a complete PL bitstream readback.
3. DMA Source Length – number of commands in the PL readback command sequence.
4. DMA Destination Length – number of readback words expected from the PL.

There are four limitations when accessing the PL configuration module:

1. Readback of configuration registers or the bitstream cannot be performed until the `devcfg.INT_STS [PCFG_DONE]` bit asserts.
2. A single PCAP readback access cannot be split across multiple DMA accesses. If the readback command sent to the PL requests 505 words, the DevC DMA must also be set up to transfer 505 words. Splitting the transaction into two DMA accesses results in data loss and unexpected DMA behavior.
3. The DMA must have sufficient bandwidth to process the PL readback due to a lack of data flow control on the PL side of the PCAP. Overflow of the PCAP RxFIFO results in data loss and unrecoverable DMA behavior. If adequate bandwidth cannot be allocated to the DevC DMA, then the PCAP clock could be slowed down or the readback could be broken up into multiple smaller transactions.
4. All DMA transactions must be 64-byte aligned to prevent accidentally crossing a 4K byte boundary.

For more information regarding PL bitstream readback, see [UG470, 7 Series FPGAs Configuration User Guide](#).

Loopback For Boot Image Transfers

The DMA controller is used to move boot images. Loopback is enabled by setting the `devcfg.MCTRL [INT_PCAP_LPBK]` bit = 1; the boot image is read into the RxFIFO and written to another memory location from the TxFIFO. The DMA source address can be to a linearly addressable flash device and the destination can be OCM or DDR memory. The PL does not need to be powered-up to use the loopback datapath. The datapath is illustrated in [Figure 6-19](#).

Note: Caution should be taken in loopback mode when transferring boot images between slave ports that prioritize writes over reads. This situation can lead to a DevC DMA hang condition.

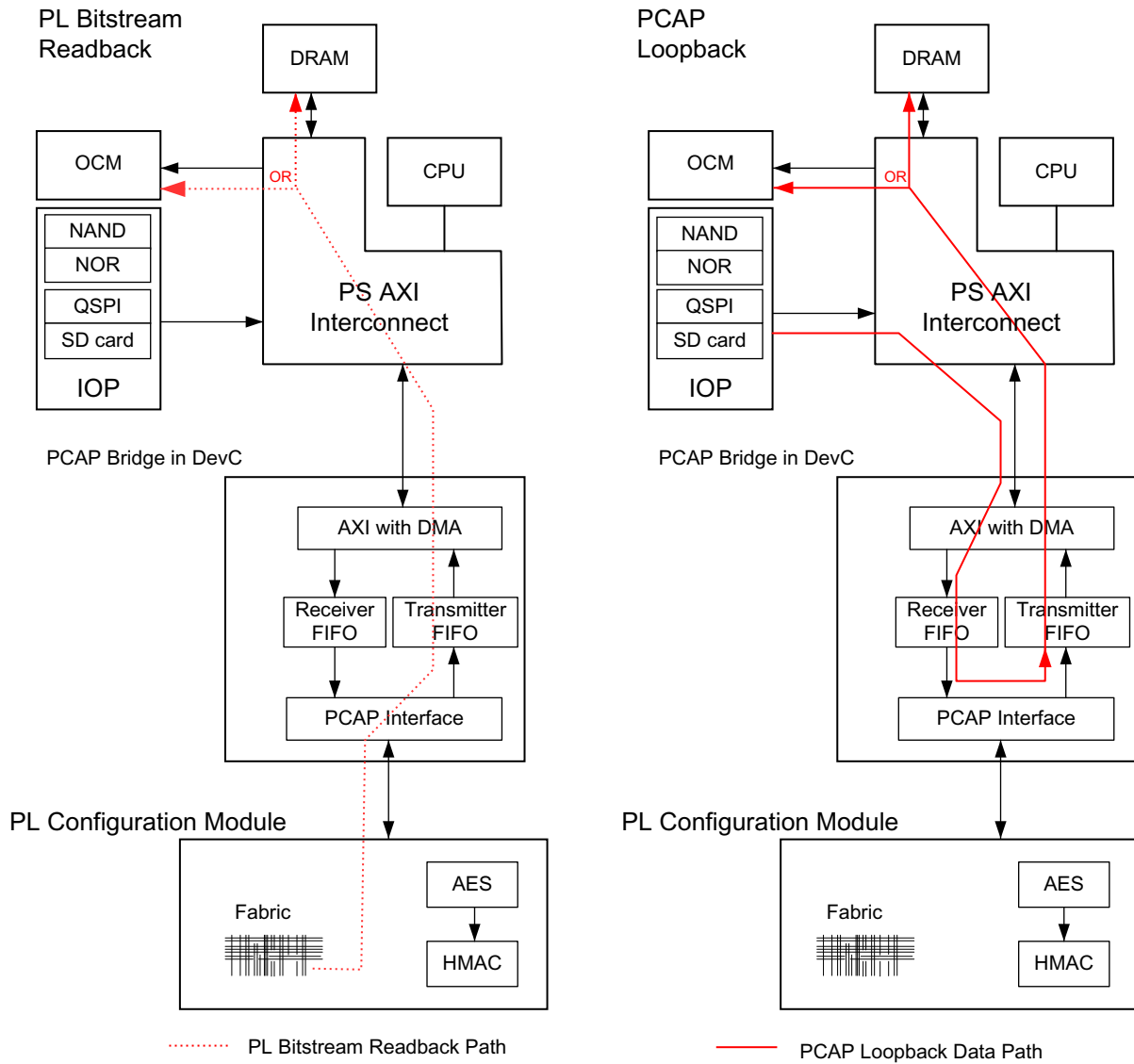

UG585_c6_13a_081514

Figure 6-19: PL Bitstream Readback and PCAP Loopback Diagrams

PL Initialization and Configuration Registers

There are several control and status bits in the devcfg register space that the PS software can use to initialize and configure the PL. These are listed in [Table 6-23](#).

Table 6-23: PL Control and Status Register Bits

| Bit Field | Bit | Type | Description |
|--------------------|-----|------|---|
| devcfg.CTRL | | | |
| [PCFG_PROG_B] | 30 | RW | PL Reset Control. Similar to pulsing the PROGRAM_B pin High-Low-High. 0: PL held in reset. 1: PL released from reset. |

Table 6-23: PL Control and Status Register Bits (Cont'd)

| Bit Field | Bit | Type | Description |
|-----------------------|-----|------|---|
| [PCFG_POR_CNT_4K] | 29 | RW | Power-up Reset Timer Rate Select. Timer is used during PL initialization. 0: Use 64K timer. 1: Use 4K timer (faster initialization of reset stage). |
| devcfg.MCTRL | | | |
| [PCFG_POR_B] | 8 | RO | PL power on/off indicator: 0: power is off. 1: power is on. |
| [INT_PCAP_LPBK] | 4 | RW | PCAP Loopback: 0: disabled, 1: enabled. |
| devcfg.STATUS | | | |
| [PSS_CFG_RESET_B] | 5 | RO | PL Reset State indicator. 0: reset state. 1: not reset state. |
| [PCFG_INIT] | 4 | RO | PL initialization complete indicator: 0: not ready. 1: ready for bitstream programming. Status interrupt for positive and negative edges: [PCFG_INIT_{PE,NE}_INT]. Maskable using devcfg.INT_MASK [M_PCFG_INIT_{PE,NE}_INT]. |
| devcfg.INT_STS | | | |
| [PSS_CFG_RESET_B_INT] | 27 | WTC | PL reset interrupt detected, either edge. Maskable using devcfg.INT_MASK [M_PSS_CFG_RESET_B_INT]. |
| PCFG_SEU_ERR_INT | 5 | RO | PL Reset State indicator. 0: reset state. 1: not reset state. |
| [PCFG_POR_B_INT] | 4 | WTC | PL loss of power interrupt. Maskable using devcfg.INT_MASK [M_PCFG_POR_B_INT]. |
| [PCFG_CFG_RST_INT] | 3 | WTC | PL configuration module reset level interrupt. Maskable using devcfg.INT_MASK [M_PCFG_CFG_RST_INT]. |
| [PCFG_DONE_INT] | 2 | WTC | PL Programming Done Indicator. 0: PL is not available. 1: Bitstream programming is complete and PL is in user mode. Maskable using devcfg.INT_MASK [M_PCFG_DONE_INT]. |
| [PCFG_INIT_PE_INT] | 1 | WTC | INIT_B Signal Positive-edge Detector Interrupt. Triggered when a positive edge is detected on the INIT_B signal. Maskable using devcfg.INT_MASK [M_PCFG_INIT_PE_INT]. |
| [PCFG_INIT_NE_INT] | 0 | WTC | INIT_B Signal Negative-edge Detector Interrupt. Triggered when a negative edge is detected on the INIT_B signal. Maskable using devcfg.INT_MASK [M_PCFG_INIT_NE_INT]. |

6.4.5 PL Control via User-JTAG

The user can initialize the PL by toggling the PROGRAM_B signal high-low-high. The PL asserts the INIT_B pin while the PL is initializing after which time the INIT_B open drain pin is left to float high.

The user can then proceed with programming the PL by accessing the Xilinx TAP controller. The control and status signals and the TAP controller connection is shown in [Figure 6-20](#).

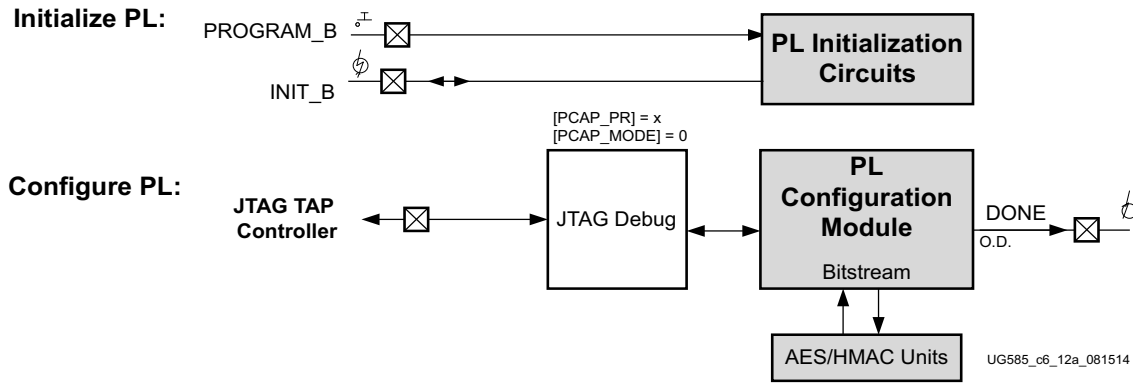

Figure 6-20: PL Initialization and Configuration Using User-JTAG

PL User Control and Status Signals

The PROGRAM_B signal can be asserted using a push button to initiate a PL initialization process. The red LED on the INIT_B signal will turn on when the PL is being initialized and then go out. At this time, the user can use the TAP controller to configure the PL. There is green LED to indicate when the DONE signal goes High. This signals that the PL has been successfully programmed. The PL initialization signal pins are part of the PL voltage domain.

Table 6-24: PL Initialization Signals

| Signal Name | Type | Description | Board Connection |
|-------------|-------------------------------|--|--|
| PROGRAM_B | Active-Low input | Reset PL Configuration Logic. The PROGRAM_B input is usually pulsed Low by external means to reset the PL and allow the PS software or JTAG TAP controller to program the PL with a bitstream. When PROGRAM_B is driven Low, the PL initialization sequence begins, causing the PL to drive the INIT_B signal Low during the process ⁽²⁾ . | External 4.7 kΩ (or stronger) pull-up resistor to V _{CCO_0} . Use a push button to GND to generate a configuration reset. |
| INIT_B | Active-Low open-drain I/O | PL Initialization Activity and Configuration Error. The PL drives the INIT_B pin Low when the PL is initializing (clearing) its configuration memory, or when the PL has detected a configuration error. ⁽¹⁾ | External 4.7 kΩ (or stronger) pull-up resistor to V _{CCO_0} to ensure clean Low-to-High transitions. |
| DONE | Active-High open-drain output | PL Configuration Done Indicator. The PL drives the DONE signal Low until the PL is successfully configured. | DONE has an internal pull-up resistor of approximately 10 kΩ. External 330Ω resistor circuits are not required. |

Notes:

1. Unlike FPGAs, the INIT_B should not be externally held Low to delay the PL configuration sequence because this is not indicated in the devcfg.STATUS [PCFG_INIT] register bit that is visible to PS software.
2. Ensure that PROGRAM_B is pulled up (High) during boot. Refer to Xilinx [AR# 56272](#).

6.5 Reference Section

This section includes content on these topics:

- Section [6.5.1 PL Configuration Considerations](#)
- Section [6.5.2 Boot Time Reference](#)
- Section [6.5.3 Register Overview](#)
- Section [6.5.4 PS Version and Device Revision](#)

6.5.1 PL Configuration Considerations

In master boot mode, the PL can be configured by PS software using the PCAP interface. Users are free to configure the PL at any time, whether it is directly after PS boot using the FSBL/User code, or at some later time using another image loaded into the PS memory. In JTAG boot mode, the PL can be configured using the TAP controller. The PL configuration paths are illustrated in [Figure 6-2, page 158](#).

PCAP/ICAP/JTAG/User Access Exclusivity

The operation of the PCAP, ICAP and JTAG interfaces to the PL configuration module are mutually exclusive. Care must be taken when switching among the three PL control paths: PCAP, JTAG and ICAP, shown in [Figure 6-2, page 158](#). Ensure that all outstanding transactions are completed before changing interfaces.

Note: The user or external logic should not assert INIT_B when using the PS software to configure the PL because the software does not have visibility to an external device delaying PL configuration.

Secure Mode PL Configuration

To perform a secure PL configuration, the PS must boot securely. The AES and HMAC units can only be enabled by the BootROM. The procedure for loading a secure bitstream is the same as loading a non-secure bitstream except the devcfg.CTRL [QUARTER_PCAP_RATE_EN] bit must be set = 1. Because the AES unit only decrypts one byte at a time, the PCAP can only send one 32-bit word to the PL for every four clock cycles.

Determine the PL State

The PL must first be powered on and initialized before it can be configured. When power is applied to the PL, it begins its independent power-on reset sequence followed by initialization which clears all of the PL configuration SRAM cells. The power-on reset status of the PL can be monitored by the PS software.

The power status of the PL is tracked in the devcfg.MCTRL [PCFG_POR_B] bit. If the [PCFG_POR_B] bit is set = 1, then the PL has power. The PL power status can also be tracked using the devcfg.INT_STS [PCFG_POR_B_INT] interrupt.

Additional information about the PL power-up status can be obtained by reading the `devcfg.STATUS [PSS_CFG_RESET_B]` register bit. If the bit is Low, then the PL is in a reset state. A transition from a Low to a High indicates the start of the PL initialization process.

PL Initialization Time Optimization

The `devcfg.CTRL [PCFG_POR_CNT_4K]` control bit can be set by the FSBL/User code to improve the initialization time of a PL power-up sequence that occurs after the FSBL/User code has had a chance to execute. In this case, the FSBL/User code sets the `[PCFG_POR_CNT_4K]` control bit and initiates a PL power-up sequence in secure or non-secure mode. This optimization is useful when the PL is powered-up by the FSBL/User code for configuration. This control bit is not accessible through the Register Initialization writes and is reset by all system resets (POR and non-POR).

This function is similar to asserting the `OVERRIDE` pin on a 7 series FPGA and may be referred to as an override function. Additional information on the use of the `[PCFG_POR_CNT_4K]` bit is described in [UG821, Zynq-7000 SoC Software Developers Guide](#).

PCAP Clocking

The bitstream datapath to the PL configuration module is clocked by the PCAP clock, which is a divided down `PCAP_2x` clock. The frequency range for the PCAP clock is specified in the data sheet. To get a 100 MHz PCAP clock, program the `PCAP_2x` clock to 200 MHz.

PCAP Throughput

In non-secure mode, the transfer rate through the PCAP is approximately 145 MB/s. The PL configuration module can accept data at the rate of 32 bits per PCAP clock, but the overall throughput is limited by the PS AXI interconnect. This approximation assumes a 100 MHz PCAP clock, a 133 MHz APB bus clock, a read issuing capability of 4 on the PS AXI interconnect, and a DMA burst length of 8.

The throughput on the interconnect can be improved by about 20% by transferring the boot image and bitstream from OCM memory and raising the `CPU_1x` clock rate by using a CPU clock ratio of 4:2:1. Refer to the data sheet for allowed clock rates.

In secure mode, the AES unit can only accept 8 bits per PCAP clock. To match this 8-bit data width with the 32-bit datapath of the PCAP interface, software must set the `devcfg.CTRL [QUARTER_PCAP_RATE_EN]` bit = 1. In this case, the demand for data by the PCAP interface is about 100 MB/s and is usually sustained by the PS AXI interconnect.

6.5.2 Boot Time Reference

Boot time activities include hardware activities, BootROM execution to configure the PS and load the FSBL/User code, PL initialization and configuration, and the load and boot time of Linux or other operating system. The factors that influence this boot process are summarized in [Table 6-25](#). Boot time is heavily influenced by:

- The bandwidth of the flash interface. This is based on the memory vendor specifications, board parameters, and optimized register values.

- The Zynq-7000 device version (affects the PL initialization time and bitstream load time).
- The size of the loaded images (e.g., Linux image size).

IMPORTANT: *The time it takes for each boot and configuration process to complete can be hard to calculate because of all the variables involved. The values provided here are meant as a guide, not a definitive answer. If you have any questions, please contact your Xilinx FAE Sales Engineer.*

Table 6-25: Factors that Affect Boot and Configuration Time

| Functional Area | Description | Boot Time Considerations |
|--|--|---|
| Zynq Device | | |
| Version | All device versions share the same PS and boot time characteristics except when the PL is involved. | PL size impacts the time for initialization (cleaning/clearing) and configuration (bitstream). |
| Security | | |
| Encryption | Decryption is required for secure boot. Software uses the AES unit in the PL. | The decryption time is highly dependent on the size of the boot image/bitstream and the PS_CLK frequency. The decryption time is also impacted by low bandwidth boot devices ⁽⁵⁾ . |
| HMAC Authentication | Authentication is done in the HMAC unit in the PL. | The HMAC authentication time depends on the PS_CLK frequency and size of the image. |
| RSA Authentication | Performed by the BootROM. | The RSA authentication time depends on many factors ⁽⁶⁾ . |
| Flash Device Attributes | | |
| Boot Device Vendor and Model | The Flash memory manufacturer and model impacts performance. | Situations vary ⁽¹⁾ . |
| Boot Interface | The performance of the boot device interface is the most important factor. | Table 6-8 shows relative performances of various boot devices in a example context. |
| Boot Interface Optimization | BootROM Header register initialization is available. | Improves the read bandwidth of the flash device all flash accesses ⁽²⁾ . |
| Execute-in-place | Quad-SPI and NOR option. | In non-secure mode, allows the CPU to execute the FSBL/User code without needing to copy it to the OCM memory. |
| PS Hardware Requirements | | |
| PS Voltage Ramp | This is power supply performance specification. A fast power supply might have a 5 to 10 ms voltage ramp time. | The minimum ramp time is provided in the data sheet. |
| PS Hardware Boot | After a POR reset, the hardware samples the strapping pins, does some hardware housekeeping. | Less than 10 microseconds. |
| PS Hardware and BootROM Options | | |
| PS PLL Startup and Lock | After a POR, the PLL programming is done by the hardware before the BootROM executes. After a non-POR reset the BootROM re-programs the PLLs and waits for them to lock before continuing execution. | PLL lock time is a data sheet specification. Refer to DS187 or DS191. The three PLLs are enabled by the BOOT_MODE [4] pin. |

Table 6-25: Factors that Affect Boot and Configuration Time (Cont'd)

| Functional Area | Description | Boot Time Considerations |
|------------------------------|--|---|
| CRC check of 128 KB ROM | This is an eFuse option that causes the BootROM to check the integrity of its own code at the beginning of execution. | Requires about 26 ms to perform (PS_CLK frequency = 33 MHz). |
| PL Hardware Functions | | |
| PL Voltage Ramp | This is power supply performance specification. A typical board might have a 10 ms voltage ramp time. | The minimum ramp time is provided in the data sheet. |
| PL Initialization | This can be done in parallel with the PS power up, or be initiated by FSBL/User code. | If the FSBL/User code runs before PL initialization, the time can be sped-up ⁽³⁾ . |
| PL T _{POR} | T _{POR} occurs when the PL is powered-up. It includes the PL Voltage Ramp time plus the PL Initialization (cleaning/clearing) time. | This time is influenced by the performance of the PL power supply and status of the PL. The range for T _{POR} is specified in the data sheet. If the PL is already powered up then only the initialization time is needed before programming the PL. |
| PL Configuration | This is done by FSBL/User code after the PL has been initialized. | This time is influenced by many factors ⁽⁴⁾ . |
| PL Partial Configuration | This is a special operation that programs only part of the PL at a time. It is used for very time-sensitive applications. | Contact your Xilinx FAE Sales Engineer to learn more about partial configuration and reconfiguration. |

Notes:

1. The device type and model depend on the Boot Mode (e.g., for Quad-SPI, this includes ability to use linear addressing mode for Flash devices ≤128Mb, or needing to use managed mode for larger devices).
2. The performance of the boot interface can be optimized by using the BootROM Header register initialization mechanism. This is most effective in non-secure mode because more registers are accessible for optimization, see [Table 6-7, page 176](#). The register initialization can also be helpful in secure mode. The available optimizations are listed for each boot device in section [6.3.3 BootROM Performance](#).
3. The PL initialization time can be decreased when the FSBL/User code executes before initializing the PL. Refer to “[PL Initialization Time Optimization](#)” section in section [6.5.1 PL Configuration Considerations](#) for information.
4. The PL configuration time is most dependent on whether the bitstream is encrypted or not. PL configuration time can be reduced by using a compressed bitstream, but the size of the compressed file cannot be predicted nor can the time to decompress the file be calculated.
5. For decryption or HMAC authentication, the PCAP configuration module must be operated at 1/4 the PCAP clock rate by setting the devcfg.CTRL [QUARTER_PCAP_RATE_EN] bit = 1.
6. RSA authentication time depends from where the boot image and bitstream are sourced from and written to, the size of the data, and the PS_CLK frequency. An example is shown in section [6.3.3 BootROM Performance](#), RSA Authentication Time.

6.5.3 Register Overview

[Table 6-26](#) provides an overview of the device configuration registers.

Table 6-26: DevC and Boot Registers

| Function | Description | Hardware Register | Type |
|---------------------------|-----------------------------------|-------------------|----------------|
| Control and configuration | Control | devcfg.CTRL | Read/Write |
| | Sticky locks require POR to reset | devcfg.LOCK | R/Sticky Write |
| | Configuration | devcfg.CFG | Read/Write |

Table 6-26: DevC and Boot Registers (Cont'd)

| Function | Description | Hardware Register | Type |
|-------------|---|-----------------------|--------------|
| DevC status | Interrupt status: PL init, done, DMA/AXI errors | devcfg.INT_STS | R + Clr or W |
| | Interrupt mask | devcfg.INT_MASK | Read/Write |
| | Status: eFuse, Init, Lockdown, PS control, DevC DMA/FIFOs | devcfg.STATUS | Read-only |
| PCAPDMA | DMA source address | devcfg.DMA_SRC_ADDR | Read/Write |
| | DMA destination address | devcfg.DMA_DST_ADDR | Read/Write |
| | DMA source length | devcfg.DMA_SRC_LEN | Read/Write |
| | DMA destination length | devcfg.DMA_DEST_LEN | Read/Write |
| Boot | Multi-Boot offset | devcfg.MULTIBOOT_ADDR | Read/Write |
| | Miscellaneous control | devcfg.MCTRL | Read/Write |
| | Reset Reason and Lockdown error code | slcr.REBOOT_STATUS | Read/Write |
| | Boot and PLL mode | slcr.BOOT_MODE | Read-only |

6.5.4 PS Version and Device Revision

The device versions and revisions are hard coded into two read-only registers. Each device is a combination of the slcr.PSS_IDCODE9 [DEVICE] and devcfg.MCTRL [PS_VERSION] register bit fields.

This *Zynq-7000 SoC Technical Reference Manual* contains information pertaining to production silicon (v3.1). The functionality of preproduction devices that is different from production devices is described in [AR# 47916](#) *Zynq-7000 SoC Devices - Silicon Revision Differences*.

Interrupts

7.1 Environment

This chapter describes the system-level interrupt environment and the functions of the interrupt controller (see Figure 7-1). The PS is based on Arm architecture, utilizing two Cortex-A9 processors (CPUs) and the GIC pl390 interrupt controller. Note that single-core devices contain one Cortex-A9 processor (CPU), dual-core devices contain two. This chapter discusses the dual-core configuration.

The interrupt structure is closely associated with the CPUs and accepts interrupts from the I/O peripherals (IOP) and the programmable logic (PL). This chapter includes these key topics:

- Private, shared and software interrupts
- GIC functionality
- Interrupt prioritization and handling

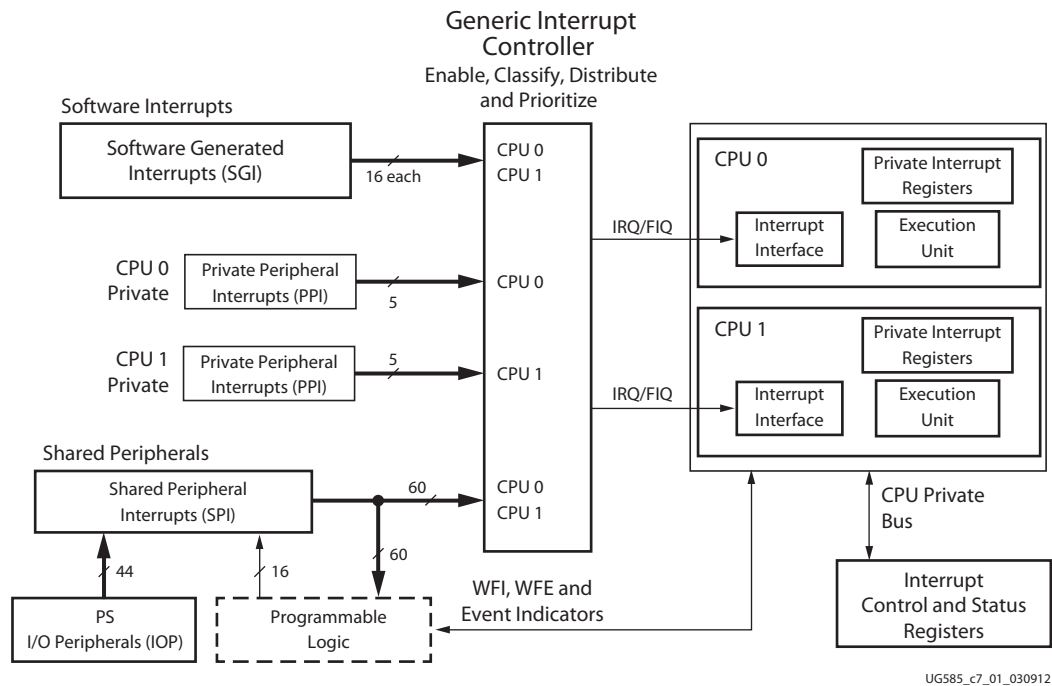

Figure 7-1: System-Level Block Diagram

7.1.1 Private, Shared and Software Interrupts

Each CPU has a set of private peripheral interrupts (PPIs) with private access using banked registers. The PPIs include the global timer, private watchdog timer, private timer, and FIQ/IRQ from the PL. Software generated interrupts (SGIs) are routed to one or both CPUs. The SGIs are generated by writing to the registers in the generic interrupt controller (GIC), refer to section [7.3 Register Overview](#). The shared peripheral interrupts (SPIs) are generated by the various I/O and memory controllers in the PS and PL. They are routed to either or both CPUs. The SPI interrupts from the PS peripherals are also routed to the PL.

7.1.2 Generic Interrupt Controller (GIC)

The generic interrupt controller (GIC) is a centralized resource for managing interrupts sent to the CPUs from the PS and PL. The controller enables, disables, masks, and prioritizes the interrupt sources and sends them to the selected CPU (or CPUs) in a programmed manner as the CPU interface accepts the next interrupt. In addition, the controller supports security extension for implementing a security-aware system.

The controller is based on the Arm Generic Interrupt Controller Architecture version 1.0 (GIC v1), non-vectored.

The registers are accessed via the CPU private bus for fast read/write response by avoiding temporary blockage or other bottlenecks in the interconnect.

The interrupt distributor centralizes all interrupt sources before dispatching the one with the highest priority to the individual CPUs. The GIC ensures that an interrupt targeted to several CPUs can only be taken by one CPU at a time. All interrupt sources are identified by a unique interrupt ID number. All interrupt sources have their own configurable priority and list of targeted CPUs.

7.1.3 Resets and Clocks

The interrupt controller is reset by the reset subsystem by writing to the PERI_RST bit of the A9_CPU_RST_CTRL register in the SLCR. The same reset signal also resets the CPU private timers and private watchdog timers (AWDT). Upon reset, all interrupts that are pending or being serviced are ignored.

The interrupt controller operates with the CPU_3x2x clock (half the CPU frequency).

7.1.4 Block Diagram

The shared peripheral interrupts are generated from various subsystems that include the I/O peripherals in the PS and logic in the PL. The interrupt sources are illustrated in [Figure 7-2](#).

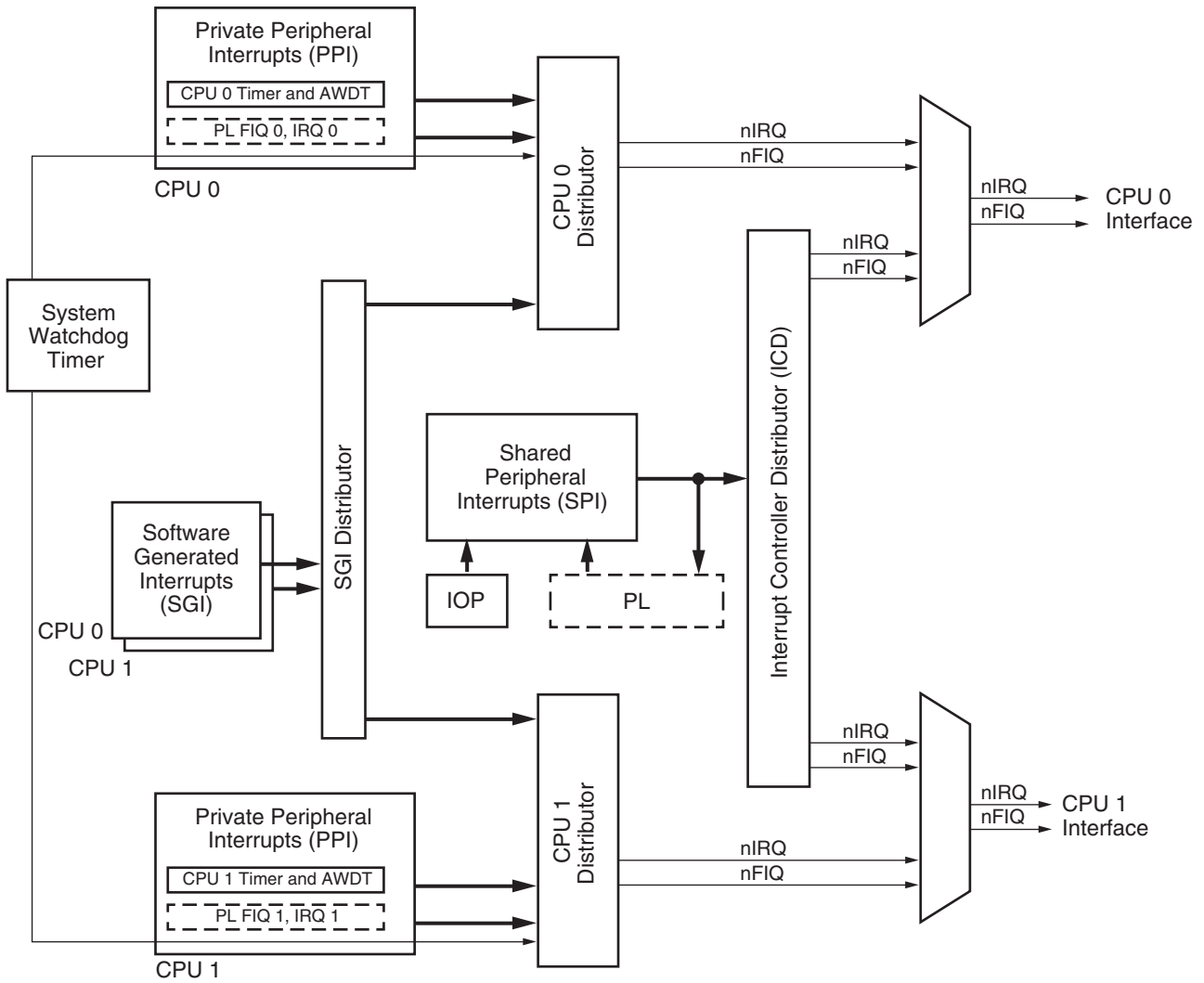

UG585_c7_02_012813

Figure 7-2: Interrupt Controller Block Diagram

7.1.5 CPU Interrupt Signal Pass-through

The IRQ/FIQ from the PL can be routed through the GIC as PPI#4 and #1, or bypass the GIC using the pass-through multiplexer shown in Figure 7-3. This logic is instantiated for both CPUs. The pass-through mode is enabled through the mpcore.ICCICR register, according to Table 7-1.

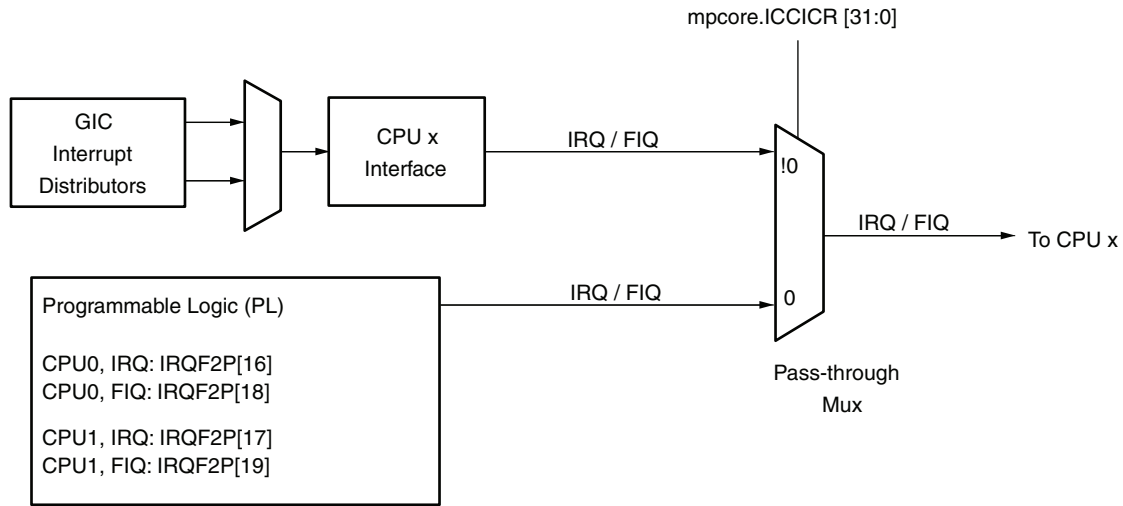

UG585_c7_03_100417

Figure 7-3: Legacy IRQ/FIQ Interrupt Pass-Through Multiplexer

Table 7-1: Pass-through Mode

| FIQEn (ICCICR[3]) | SecureS (ICCICR[0]) | SecureNS (ICCICR[1]) | IRQ to CPU x | FIQ to CPU x |
|-------------------|---------------------|----------------------|---------------|---------------|
| 0 | 0 | 0 | pass through | pass through |
| 0 | 0 | 1 | driven by GIC | pass through |
| 0 | 1 | 0 | driven by GIC | pass through |
| 0 | 1 | 1 | driven by GIC | pass through |
| 1 | 0 | 0 | pass through | pass through |
| 1 | 0 | 1 | driven by GIC | pass through |
| 1 | 1 | 0 | pass through | driven by GIC |
| 1 | 1 | 1 | driven by GIC | driven by GIC |

7.2 Functional Description

7.2.1 Software Generated Interrupts (SGI)

Each CPU can interrupt itself, the other CPU, or both CPUs using a software generated interrupt (SGI). There are 16 software generated interrupts (see Table 7-2). An SGI is generated by writing the SGI interrupt number to the ICDSGIR register and specifying the target CPU(s). This write occurs via the CPU's own private bus. Each CPU has its own set of SGI registers to generate one or more of the 16 software generated interrupts. The interrupts are cleared by reading the ICCIAR (Interrupt Acknowledge) register or writing a 1 to the corresponding bits of the ICDICPR (Interrupt Clear-Pending) register.

All SGIs are edge triggered. The sensitivity types for SGIs are fixed and cannot be changed; the ICDICFR0 register is read-only, since it specifies the sensitivity types of all the 16 SGIs.

Table 7-2: Software Generated Interrupts (SGI)

| IRQ ID# | Name | SGI# | Type | Description |
|---------|-------------|------|-------------|---|
| 0 | Software 0 | 0 | Rising edge | A set of 16 interrupt sources that are private to each CPU that can be routed to up to 16 common interrupt destinations where each destination can be one or more CPUs. |
| 1 | Software 1 | 1 | Rising edge | |
| ~ | ... | ~ | ... | |
| 15 | Software 15 | 15 | Rising edge | |

7.2.2 CPU Private Peripheral Interrupts (PPI)

Each CPU connects to a private set of five peripheral interrupts. The PPIs are listed in Table 7-3.

The sensitivity types for PPIs are fixed and cannot be changed; therefore, the ICDICFR1 register is read-only, since it specifies the sensitivity types of all the 5 PPIs. Note that the fast interrupt (FIQ) signal and the interrupt (IRQ) signal from the PL are inverted and then sent to the interrupt controller. Therefore, they are active High at the PS-PL interface, although the ICDICFR1 register reflects them as active Low level.

Table 7-3: Private Peripheral Interrupts (PPI)

| IRQ ID# | Name | PPI# | Type | Description |
|---------|-------------------|------|--|--|
| 26:16 | Reserved | ~ | ~ | Reserved |
| 27 | Global Timer | 0 | Rising edge | Global timer |
| 28 | nFIQ | 1 | Active Low level (active High at PS-PL interface) | Fast interrupt signal from the PL: CPU0: IRQF2P[18] CPU1: IRQF2P[19] |
| 29 | CPU Private Timer | 2 | Rising edge | Interrupt from private CPU timer |
| 30 | AWDT{0, 1} | 3 | Rising edge | Private watchdog timer for each CPU |
| 31 | nIRQ | 4 | Active Low level (active High at PS-PL interface) | Interrupt signal from the PL: CPU0: IRQF2P[16] CPU1: IRQF2P[17] |

7.2.3 Shared Peripheral Interrupts (SPI)

A group of approximately 60 interrupts from various modules can be routed to one or both of the CPUs or the PL. The interrupt controller manages the prioritization and reception of these interrupts for the CPUs.

Except for IRQ #61 through #68 and #84 through #91, all interrupt sensitivity types are fixed by the requesting sources and cannot be changed. The GIC must be programmed to accommodate this. The boot ROM does not program these registers; therefore the SDK device drivers must program the GIC to accommodate these sensitivity types.

For an interrupt of level sensitivity type, the requesting source must provide a mechanism for the interrupt handler to clear the interrupt after the interrupt has been acknowledged. This requirement applies to any IRQF2P[n] (from PL) with a high level sensitivity type.

For an interrupt of rising edge sensitivity, the requesting source must provide a pulse wide enough for the GIC to catch. This is normally at least 2 CPU_2x3x periods. This requirement applies to any IRQF2P[n] (from PL) with a rising edge sensitivity type.

The ICDICFR2 through ICDICFR5 registers configure the interrupt types of all the SPIs. Each interrupt has a 2-bit field, which specifies sensitivity type and handling model.

The SPI interrupts are listed in [Table 7-4](#).

Table 7-4: PS and PL Shared Peripheral Interrupts (SPI)

| Source | Interrupt Name | IRQ ID# | Status Bits (mpcore Registers) | Required Type | PS-PL Signal Name | I/O |
|----------|--------------------------|------------------|--------------------------------|-------------------|-------------------|--------|
| APU | CPU 1, 0 (L1, TLB, BTAC) | 33:32 | spi_status_0[1:0] | Rising edge | ~ | ~ |
| | L2 Cache | 34 | spi_status_0[2] | High level | ~ | ~ |
| | OCM | 35 | spi_status_0[3] | High level | ~ | ~ |
| Reserved | ~ | 36 | spi_status_0[3] | ~ | ~ | ~ |
| PMU | PMU [1,0] | 38, 37 | spi_status_0[6:5] | High level | ~ | ~ |
| XADC | XADC | 39 | spi_status_0[7] | High level | ~ | ~ |
| DevC | DevC | 40 | spi_status_0[8] | High level | ~ | ~ |
| SWDT | SWDT | 41 | spi_status_0[9] | Rising edge | ~ | ~ |
| Timer | TTC 0 | 44:42 | spi_status_0[12:10] | High level | ~ | ~ |
| DMAC | DMAC Abort | 45 | spi_status_0[13] | High level | IRQP2F[28] | Output |
| | DMAC [3:0] | 49:46 | spi_status_0[17:14] | High level | IRQP2F[23:20] | Output |
| Memory | SMC | 50 | spi_status_0[18] | High level | IRQP2F[19] | Output |
| | Quad SPI | 51 | spi_status_0[19] | High level | IRQP2F[18] | Output |
| Reserved | ~ | ~ | ~ | Always driven Low | IRQP2F[17] | Output |
| IOP | GPIO | 52 | spi_status_0[20] | High level | IRQP2F[16] | Output |
| | USB 0 | 53 | spi_status_0[21] | High level | IRQP2F[15] | Output |
| | Ethernet 0 | 54 | spi_status_0[22] | High level | IRQP2F[14] | Output |
| | Ethernet 0 Wake-up | 55 | spi_status_0[23] | Rising edge | IRQP2F[13] | Output |
| | SDIO 0 | 56 | spi_status_0[24] | High level | IRQP2F[12] | Output |
| | I2C 0 | 57 | spi_status_0[25] | High level | IRQP2F[11] | Output |
| | SPI 0 | 58 | spi_status_0[26] | High level | IRQP2F[10] | Output |
| | UART 0 | 59 | spi_status_0[27] | High level | IRQP2F[9] | Output |
| CAN 0 | 60 | spi_status_0[28] | High level | IRQP2F[8] | Output | |

Table 7-4: PS and PL Shared Peripheral Interrupts (SPI) (Cont'd)

| Source | Interrupt Name | IRQ ID# | Status Bits (mpcore Registers) | Required Type | PS-PL Signal Name | I/O |
|----------|--------------------|---------|--------------------------------|----------------------------|-------------------|--------|
| PL | PL [2:0] | 63:61 | spi_status_0[31:29] | Rising edge/ High level | IRQF2P[2:0] | Input |
| | PL [7:3] | 68:64 | spi_status_1[4:0] | Rising edge/ High level | IRQF2P[7:3] | Input |
| Timer | TTC 1 | 71:69 | spi_status_1[7:5] | High level | ~ | ~ |
| DMAC | DMAC[7:4] | 75:72 | spi_status_1[11:8] | High level | IRQP2F[27:24] | Output |
| IOP | USB 1 | 76 | spi_status_1[12] | High level | IRQP2F[7] | Output |
| | Ethernet 1 | 77 | spi_status_1[13] | High level | IRQP2F[6] | Output |
| | Ethernet 1 Wake-up | 78 | spi_status_1[14] | Rising edge | IRQP2F[5] | Output |
| | SDIO 1 | 79 | spi_status_1[15] | High level | IRQP2F[4] | Output |
| | I2C 1 | 80 | spi_status_1[16] | High level | IRQP2F[3] | Output |
| | SPI 1 | 81 | spi_status_1[17] | High level | IRQP2F[2] | Output |
| | UART 1 | 82 | spi_status_1[18] | High level | IRQP2F[1] | Output |
| | CAN 1 | 83 | spi_status_1[19] | High level | IRQP2F[0] | Output |
| PL | PL [15:8] | 91:84 | spi_status_1[27:20] | Rising edge/ High level | IRQF2P[15:8] | Input |
| SCU | Parity | 92 | spi_status_1[28] | Rising edge | ~ | ~ |
| Reserved | ~ | 95:93 | spi_status_1[31:29] | ~ | ~ | ~ |

7.2.4 Interrupt Sensitivity, Targeting and Handling

There are three types of interrupts that come into the GIC as explained in section : SPI, PPI and SGI. In a general sense, the interrupt signals includes a sensitivity setting, whether one or both CPUs handle the interrupt, and which CPU or CPUs are targeted: zero, one, or both. However, the functionality of most interrupt signals include fixed settings, while others are partially programmable.

There are two sets of control registers for sensitivity, handling, and targeting:

- mpcore.ICDICFR[5:0] registers: sensitivity and handling. See [Figure 7-4](#).
- mpcore.ICDIPTR[23:0] registers: targeting CPU(s). See [Figure 7-5](#).

Shared Peripheral Interrupts (SPI)

The SPI interrupts can be targeted to any number of CPUs, but only one CPU handles the interrupt. If an interrupt is targeted to both CPUs and they respond to the GIC at the same time, the MPcore ensures that only one of the CPUs reads the active interrupt ID#. The other CPU receives the Spurious ID# 1023 interrupt or the next pending interrupt, depending on the timing. This removes the requirement for a lock in the interrupt service routine. Targeting the CPU is done by the ICDIPTR [23:8] registers. The sensitivity of each SPI interrupt must be programmed to match those listed in

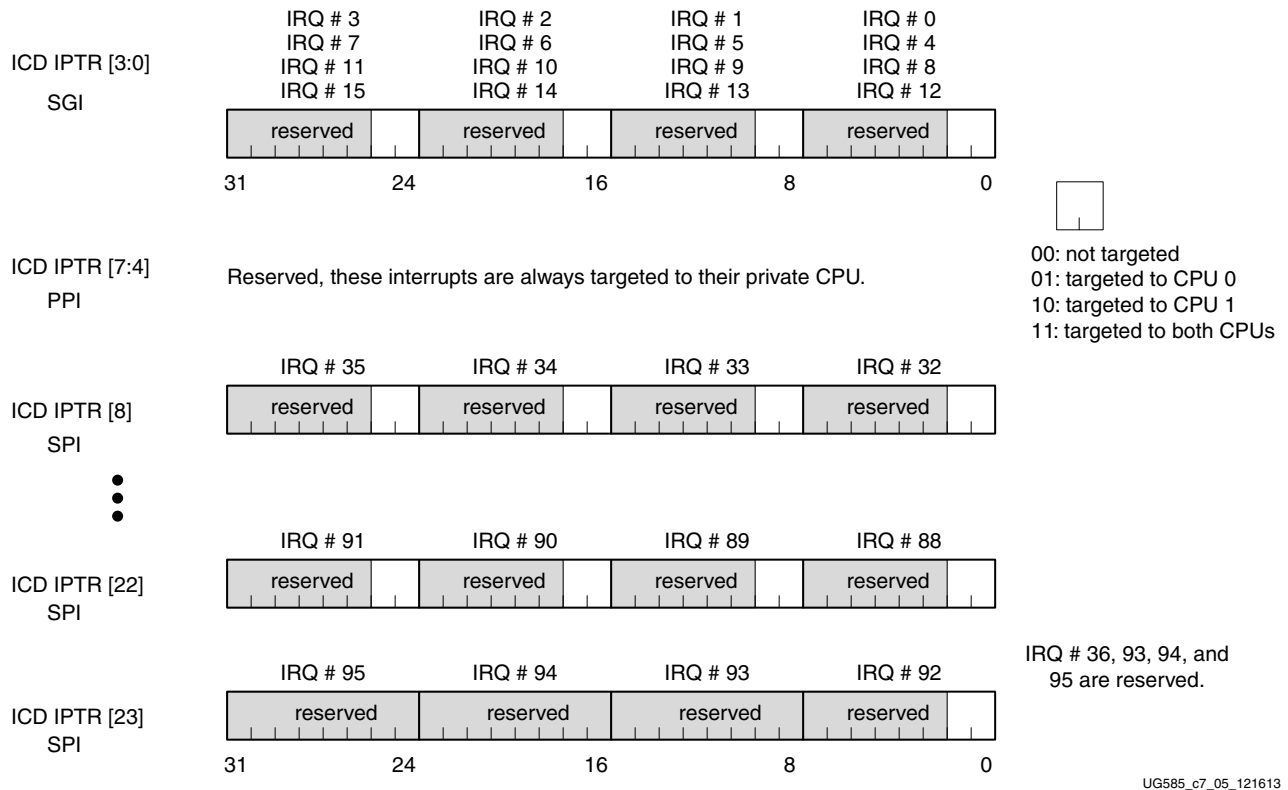

Figure 7-5: Interrupts ICDIPTR Register for Targeting CPU

7.2.5 Wait for Interrupt Event Signal (WFI)

The CPU can go into a wait state where it waits for an interrupt (or event) signal to be generated. The wait for interrupt signal that is sent to the PL is described in [Chapter 3, Application Processing Unit](#).

7.3 Register Overview

The ICC and ICD registers are part of the pl390 GIC register set. There are 60 SPI interrupts. This is far fewer than what the pl390 can support, so there are far fewer interrupt enable, status, prioritization and processor target registers in the ICD than is possible for the pl390. A summary of the ICC and ICD registers are listed in [Table 7-5](#)

Table 7-5: Interrupt Controller Register Overview

| Name | Register Description | Write Protection Lock |
|---------------------------------------|-------------------------------------|-----------------------|
| Interrupt Controller CPU (ICC) | | |
| ICCICR | CPU interface control | Yes, except EnableNS |
| ICCPMR | Interrupt priority mask | ~ |
| ICCBPR | Binary point for interrupt priority | ~ |

Table 7-5: Interrupt Controller Register Overview (Cont'd)

| Name | Register Description | Write Protection Lock |
|---|---|-----------------------|
| ICCIAR | Interrupt acknowledge | ~ |
| ICCEOIR | End of interrupt | ~ |
| ICCRPR | Running priority | ~ |
| ICCHPIR | Highest pending interrupt | ~ |
| ICCABPR | Aliased non-secure binary point | ~ |
| Interrupt Controller Distributor (ICD) | | |
| ICDDCR | Secure/non-secure mode select | Yes |
| ICDICTR, ICDIIDR | Controller implementation | ~ |
| ICDISR [2:0] | Interrupt security | Yes |
| ICDISER [2:0], ICDICER [2:0] | Interrupt set-enable and clear-enable | Yes |
| ICDISPR [2:0], ICDICPR [2:0] | Interrupt set-pending and clear-pending | Yes |
| ICDABR [2:0] | Interrupt active | ~ |
| ICDIPR [23:0] | Interrupt priority, 8-bit fields. Only the upper 5 bits of each 8-bit field are writable; the lower bits are always 0. There are 32 priority levels. | Yes |
| ICDIPTR [23:0] | Interrupt processor targets, 8-bit fields. | Yes |
| ICDICFR [5:0] | Interrupt sensitivity type, 2-bit fields (level/edge, handling model) | Yes |
| PPI and SPI Status | | |
| PPI_STATUS | PPI status: Corresponds to ICDISR[0], ICDISER[0], ICDICER[0], ICDISPR[0], ICDICPR[0], and ICDABR[0] registers (security, enable, pending and active). | ~ |
| SPI_STATUS [2:1] | SPI status: Corresponds to ICDISR[2:1], ICDISER[2:1], ICDICER[2:1], ICDISPR[2:1], ICDICPR[2:1], and ICDABR[2:1] registers (security, enable, pending and active). | ~ |
| Software Generated Interrupts (SGI) | | |
| ICDSGIR | Software-generated interrupts | ~ |
| Disable Write Accesses (SLCR register) | | |
| APU_CTRL | CFGSDISABLE bit disables some write accesses | ~ |

7.3.1 Write Protection Lock

The interrupt controller provides the facility to prevent write accesses to critical configuration registers. This is done by writing a one to the APU_CTRL[CFGSDISABLE] bit. The APU_CTRL register is part of the SoC's System Level Control register set, SLCR. This controls the write behavior for the secure interrupt control registers.



RECOMMENDED: *If the user wants to set the CFGSDISABLE bit, it is recommended that this be done during the user software boot process which occurs after the software has configured the Interrupt*

Controller registers. The CFGSDISABLE bit can only be cleared by a power-on reset (POR.) After the CFGSDISABLE bit is set, it changes the protected register bits to read-only and therefore the behavior of these secure interrupts cannot be changed, even in the presence of rogue code executing in the secure domain.

7.4 Programming Model

7.4.1 Interrupt Prioritization

All of the interrupt requests (PPI, SGI and SPI) are assigned a unique ID number. The controller uses the ID number to arbitrate. The interrupt distributor holds the list of pending interrupts for each CPU, and then selects the highest priority interrupt before issuing it to the CPU interface. Interrupts of equal priority are resolved by selecting the lowest ID.

The prioritization logic is physically duplicated to enable the simultaneous selection of the highest priority interrupt for each CPU. The interrupt distributor holds the central list of interrupts, processors and activation information, and is responsible for triggering software interrupts to the CPUs.

SGI and PPI distributor registers are banked to provide a separate copy for each connected processor. Hardware ensures that an interrupt targeting several CPUs can only be taken by one CPU at a time.

The interrupt distributor transmits to the CPU interfaces the highest pending interrupt. It receives back the information that the interrupt has been acknowledged, and can then change the status of the corresponding interrupt. Only the CPU that acknowledges the interrupt can end that interrupt.

7.4.2 Interrupt Handling

The response of the GIC to a pending interrupt when an IRQ line de-asserts is described in the Arm document: *IHI0048B_gic_architecture_specification.pdf* (see [Appendix A, Additional Resources](#)). See the Note in Section 1.4.2 with additional information in Section 3.2.4.

If the interrupt is pending in the GIC and IRQ is de-asserted, the interrupt in the GIC becomes inactive (and the CPU never sees it).

If the interrupt is active in the GIC (because the CPU interface has acknowledged the interrupt), then the software ISR determines the cause by checking the GIC registers first and then polling the I/O Peripheral interrupt status registers.

7.4.3 Arm Programming Topics

The Arm GIC architecture specification includes these programming topics:

- GIC register access

- Distributor and CPU Interfaces
- Affects of the GIC security extensions
- PU Interface registers
- Preserving and restoring controller state

7.4.4 Legacy Interrupts and Security Extensions

When the legacy interrupts (IRQ, FIQ) are used, and an interrupt handler accesses both IRQs and FIQs in secure mode (via `ICCICR[AckCtl]=1`), race conditions occasionally occur when reading the interrupt IDs. There is also a risk of seeing FIQ IDs in the IRQ handler, as the GIC only knows what security state the handler is reading from, not which type of handler.

There are two workable solutions:

- Only signal IRQs to a re-entrant IRQ handler and use the preemption feature in the GIC.
- Use FIQ and IRQ with `ICCICR[AckCtl]=0` and use the TLB tables to handle IRQ in non-secure mode, and handle FIQ in secure mode.

Timers

8.1 Introduction

Each Cortex-A9 processor has its own private 32-bit timer and 32-bit watchdog timer. Both processors share a global 64-bit timer. These timers are always clocked at 1/2 of the CPU frequency (CPU_3x2x).

On the system level, there is a 24-bit watchdog timer and two 16-bit triple timer/counters. The system watchdog timer is clocked at 1/4 or 1/6 of the CPU frequency (CPU_1x), or can be clocked by an external signal from an MIO pin or from the PL. The two triple timers/counters are always clocked at 1/4 or 1/6 of the CPU frequency (CPU_1x), and are used to count the widths of signal pulses from an MIO pin or from the PL.

8.1.1 System Diagram

The relationships of the system timers are shown in [Figure 8-1](#).

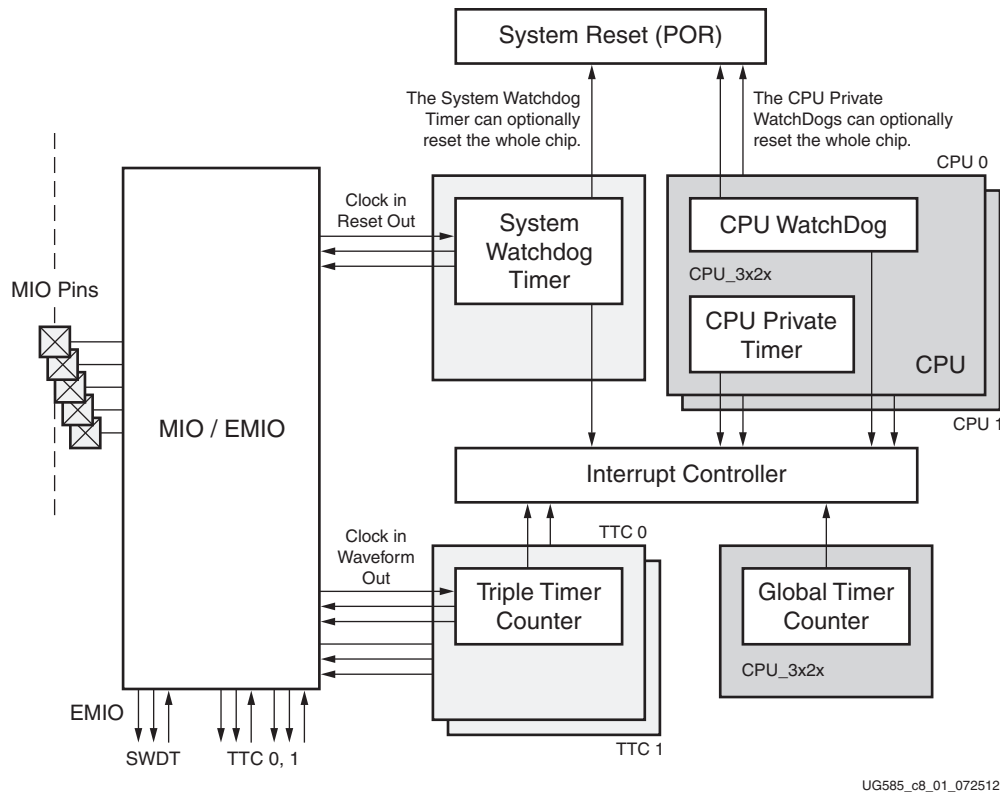

Figure 8-1: System View

8.1.2 Notices

7z007s and 7z007s CLG225 Devices

The 7z007s single core and 7z010 dual core CLG225 devices support 32 MIO pins (not 54). This is shown in the MIO table in section [2.5.4 MIO-at-a-Glance Table](#). The 7z007s and 7z010 CLG225 devices restrict the available MIO pins so connections through the EMIO might need to be considered. All of the 7z007s and 7z010 CLG225 device restrictions are listed in section [1.1.3 Notices](#).

8.2 CPU Private Timers and Watchdog Timers

The CPU private timers and watchdog timers are fully documented in the *Cortex-A9 MPCore Technical Requirements Document*, sections 4.1 and 4.2 (see [Appendix A, Additional Resources](#)).

Both the timer and watchdog blocks have the following features:

- 32-bit counter that generates an interrupt when it reaches zero
- 8-bit prescaler to enable better control of the interrupt period
- Configurable single-shot or auto-reload modes
- Configurable starting values for the counter

8.2.1 Clocking

All private timers and watchdog timers are always clocked at 1/2 of the CPU frequency (CPU_3x2x).

8.2.2 Interrupt to PS Interrupt Controller

The interrupts sent to the interrupt controller are described in section [7.2.2 CPU Private Peripheral Interrupts \(PPI\)](#).

8.2.3 Resets

The time and watchdog resets are sent to the PS reset subsystem, see section [26.3 Reset Effects](#).

8.2.4 Register Overview

A register overview of the CPU private and watchdog timers is provided in [Table 8-1](#).

Table 8-1: CPU Private Timers Register Overview

| Function | Name | Overview |
|---|--|---|
| CPU Private Timers | | |
| Reload and current values | Timer Load Timer Counter | Values to be reloaded into the decrementer. Current value of the decrementer. |
| Control and interrupt | Timer Control Timer Interrupt | Enable, auto reload, IRQ, prescaler, interrupt status. |
| CPU Private Watchdogs (AWDT 0 and 1) | | |
| Reload and current values | Watchdog Load Watchdog Counter | Values to be reloaded into the decrementer. Current value of the decrementer. |
| Control and interrupt | Watchdog Control Watchdog Interrupt | Enable, Auto reload, IRQ, prescaler, interrupt status. (this register cannot disable watchdog) |

Table 8-1: CPU Private Timers Register Overview (Cont'd)

| Function | Name | Overview |
|--------------|-----------------------|---|
| Reset status | Watchdog Reset Status | Reset status as a result of watchdog reaching 0. Cleared with POR only, so SW can tell if the reset was caused by watchdog. |
| Disable | Watchdog Disable | Disable watchdog through a sequence of writes of two specific words. |

8.3 Global Timer (GT)

The Global Timer is fully documented in the *Cortex-A9 MPCore Technical Requirements Document*, sections 4.3 and 4.4 (see [Appendix A, Additional Resources](#)). The global timer is a 64-bit incrementing counter with an auto-incrementing feature. The global timer is memory mapped in the same address space as the private timers. The global timer is accessed at reset in secure state only. The global timer is accessible to all Cortex-A9 processors. Each Cortex-A9 processor has a 64-bit comparator that is used to assert a private interrupt when the global timer has reached the comparator value.

8.3.1 Clocking

The GTC is always clocked at 1/2 of the CPU frequency (CPU_3x2x).

8.3.2 Register Overview

A register overview of the GTC is provided in [Table 8-2](#).

Table 8-2: Global Timer Register Overview

| Function | Name | Overview |
|---------------------------|--|--|
| Global Timer (GTC) | | |
| Current values | Global Timer Counter | Current value of the incrementer |
| Control and interrupt | Global Timer Control Global Interrupt | Enable timer, enable comparator, IRQ, auto-increment, interrupt status |
| Comparator | Comparator Value Comparator Increment | Current value of the comparator Increment value for the comparator |
| | Global Timer Disable | Disable watchdog through a sequence of writes of two specific words |

8.4 System Watchdog Timer (SWDT)

In addition to the two CPU private watchdog timers, there is a system watchdog timer (SWDT) for signaling additional catastrophic system failure, such as a PS PLL failure. Unlike the AWDT, the SWDT can run off the clock from an external device or the PL, and provides a reset output to an external device or the PL.

8.4.1 Features

Key features of the available timers/counters are as follows:

- An internal 24-bit counter
- Selectable clock input from:
 - Internal PS bus clock (CPU_1x)
 - Internal clock (from PL)
 - External clock (from MIO)
- On timeout, outputs one or a combination of:
 - System interrupt (PS)
 - System reset (PS, PL, MIO)
- Programmable timeout period:
 - Timeout range 32,760 to 68,719,476,736 clock cycles (330 μ s to 687.2s at 100 MHz)
- Programmable output signal duration on timeout:
 - System interrupt pulse 4, 8, 16, or 32 clock cycles (CPU_1x clock)

8.4.2 Block Diagram

A block diagram of the SWDT is shown in [Figure 8-2](#).

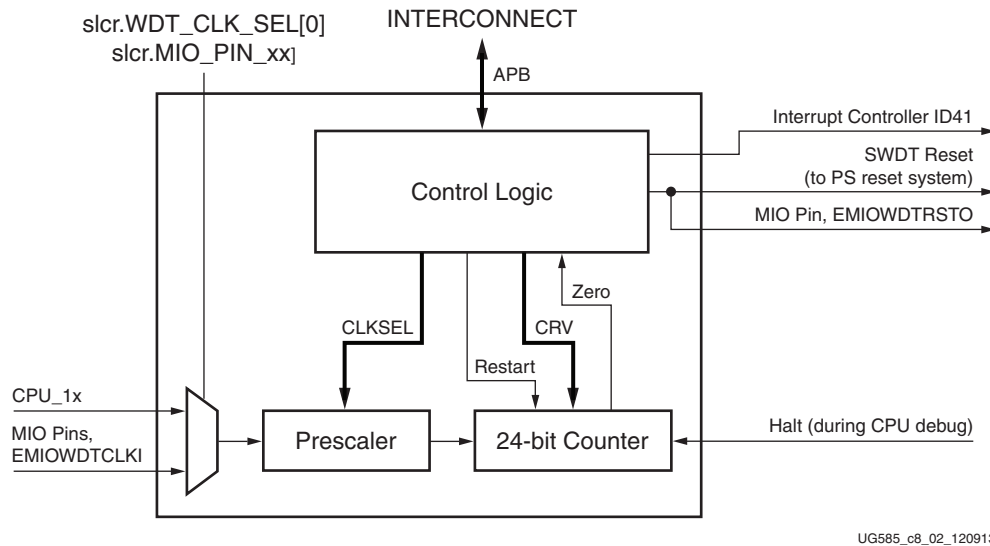

Figure 8-2: System Watchdog Timer Block Diagram

Notes relevant to [Figure 8-2](#):

- SLCR programmable registers (WDT_CLK_SEL, MIO control) select the clock input.
- SWDT programmable registers set the values for CLKSEL and CRV.
- Signal *restart* causes the 24-bit counter to reload the CRV values, and restart counting.
- Signal *halt* causes the counter to halt during CPU debug (same behavior as AWDT).

8.4.3 Functional Description

The control logic block has an APB interface connected to the system interconnect. Each write data received from the APB has a key field which must match the key of the register in order to be able to write to the register.

The Zero Mode register controls the behavior of the SWDT when its internal 24-bit counter reaches zero. Upon receiving a *zero* signal, the control logic block asserts the interrupt output signal for IRQLN clock cycles if both WDEN and IRQEN are set, and also asserts the reset output signals for approximately one CPU_1x cycle if WDEN is set. The 24-bit counter then stays at zero until it is restarted.

The Counter Control register sets the timeout period, by setting reload values in `swdt.CONTROL[CLKSET]` and `swdt.CONTROL[CRV]` to control the prescaler and the 24-bit counter.

The Restart register is used to restart the counting process. Writing to this register with a matched key causes the prescaler and the 24-bit counter to reload the values from CRV signals.

The Status register shows whether the 24-bit counter reaches zero. Regardless of the WDEN bit in the Zero Mode register, the 24-bit counter always keeps counting down to zero if it is not zero and the selected clock source is present. Once it reaches zero, the WDZ bit of the Status register is set and remains set until the 24-bit counter is restarted.

The prescaler block divides down the selected clock input. The CLKSEL signal is sampled at every rising clock edge.

The internal 24-bit counter counts down to zero and stays at zero until it is restarted. While the counter is at zero, the zero output signal is High.

Interrupt to PS Interrupt Controller

The pulse length from the SWDT (four CPU_1x clock cycles) is sufficient for the interrupt controller to capture the interrupt using rising-edge sensitivity.

Reset

The watchdog reset is sent to the PS reset subsystem to cause a non-POR reset, see section 26.3 [Reset Effects](#). The reset output to the MIO pin or EMIOWDTRSTO is active High.



TIP: To generate a signal pulse for the PS_POR_B and other board resets, route the EMIOWDTRSTO signal from the SWDT through the PL and to a pin that can be externally latched to generate a valid reset pulse. It is recommended to use an external watchdog timer device that is managed by PS software via a GPIO output pin in secure mode. The PS_POR_B reset pulse width requirements are defined in the data sheet.

8.4.4 Register Overview

A register overview of the SWDT is provided in [Table 8-3](#).

Table 8-3: System Watchdog Timer Register Overview

| Function | Name | Overview |
|---------------|--------------------|---|
| Clock select | slcr.WDT_CLK_SEL | Selects between the CPU_1x and external clock source (MIO/EMIO). |
| MIO routing | slcr.MIO_PIN_xx | Routes the SWDT clock input through the MIO multiplexer or EMIO if no MIO routing. |
| Reset reason | slcr.REBOOT_STATUS | The [SWDT_RST] bit gets set when the SWDT generates a system reset. |
| Zero mode | swdt.MODE | Enable SWDT, enable interrupt and reset outputs on timeout, set output pulse lengths. |
| Reload values | swdt.CONTROL | Set the reload values for prescaler and 24-bit counter on timeout. |
| Restart | swdt.RESTART | Cause the prescaler and the 24-bit counter to reload and restart. |
| Status | swdt.STATUS | Indicates watchdog reaching zero. |

8.4.5 Programming Model

System Watchdog Timer Enable Sequence

1. Select clock input source using the `slcr.WDT_CLK_SEL[SEL]` bit:

Ensure that the SWDT is disabled (`swdt.MODE[WDEN] = 0`) and the clock input source to be selected is running before proceeding with this step. Changing the clock input source when the SWDT is enabled results in unpredictable behavior. Changing the clock input source to a non-running clock results in APB access hang.

2. Set the timeout period (Counter Control register):

The `swdt.CONTROL[CKEY]` field must be `0x248` to be able to write this register.

3. Enable the counter; enable output pulses; set up output pulse lengths (Zero Mode register):

The `swdt.MODE[ZKEY]` field must be `0xABC` to be able to write this register. Ensure that `IRQLN` meets the specified minimum values.

4. To run the SWDT with a different setting, disable the timer first (`swdt.MODE[ZKEY]` bit). Then repeat steps 1, 2, and 3.

8.4.6 Clock Input Option for SWDT

The following code shows how the SoC selects the clock source for SWDT:

```
if slcr.WDT_CLK_SEL[0] is 0, use CPU_1X
else if slcr.MIO_PIN_14[7:0] is 01100000, use MIO pin 14
else if slcr.MIO_PIN_26[7:0] is 01100000, use MIO pin 26
else if slcr.MIO_PIN_38[7:0] is 01100000, use MIO pin 38
else if slcr.MIO_PIN_50[7:0] is 01100000, use MIO pin 50
else if slcr.MIO_PIN_52[7:0] is 01100000, use MIO pin 52
else use EMIOWDTCCLKI
```

8.4.7 Reset Output Option for SWDT

The following code shows how the SoC selects the reset output pin for SWDT:

```
if slcr.MIO_PIN_15[7:0] is 01100000, use MIO pin 15
else if slcr.MIO_PIN_27[7:0] is 01100000, use MIO pin 27
else if slcr.MIO_PIN_39[7:0] is 01100000, use MIO pin 39
else if slcr.MIO_PIN_51[7:0] is 01100000, use MIO pin 51
else if slcr.MIO_PIN_53[7:0] is 01100000, use MIO pin 53
else use EMIOWDTRSTO
```

8.5 Triple Timer Counters (TTC)

The TTC contains three independent timers/counters. There are two TTC modules in the PS, for a total of six timers/counters. TTC 1 controller can be configured for secure or non-secure mode using the `nic301_addr_region_ctrl_registers.security_apb [ttc1_apb]` register bit. The three timers within a TTC controller have the same security state.

8.5.1 Features

Each of the triple timer counters has:

- Three independent 16-bit prescalers and 16-bit up/down counters
- Selectable clock input from:
 - Internal PS bus clock (CPU_1x)
 - Internal clock (from PL)
 - External clock (from MIO)
- Three interrupts, one for each counter
- Interrupt on overflow, at regular interval, or counter matching programmable values
- Generates waveform output (for example, PWM) through the MIO and to the PL

8.5.2 Block Diagram

A block diagram of the TTC is shown in [Figure 8-3](#). The clock-in and wave-out multiplexing for Timer/Clock 0 is controlled by the `slcr.MIO_PIN_xx` registers. If no selection is made in these registers, then the default becomes the EMIO interface.

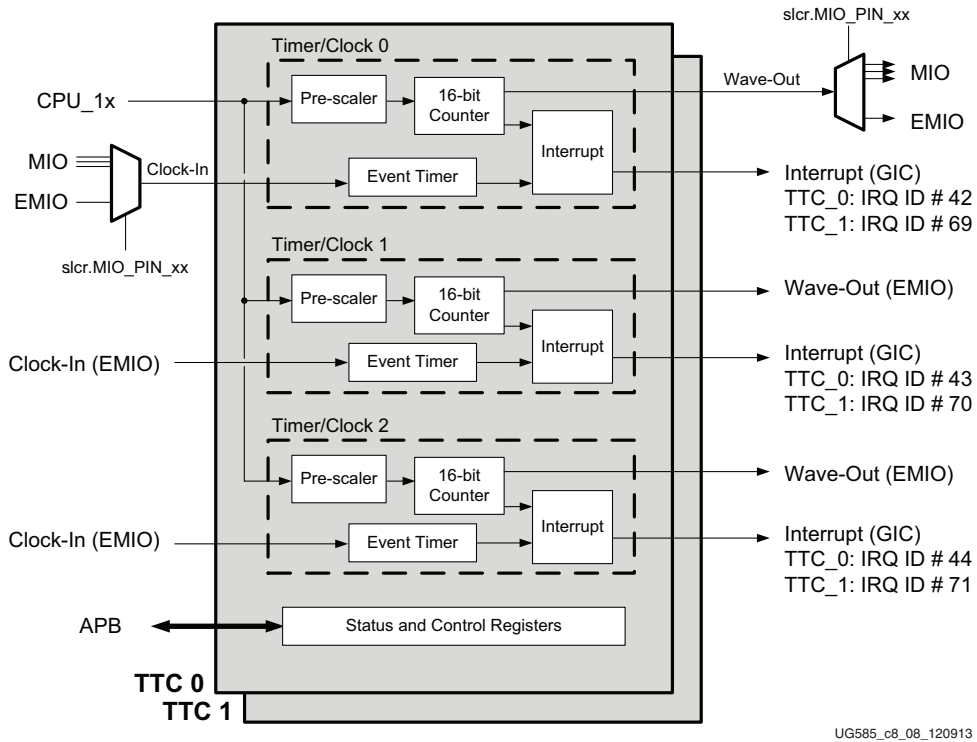

Figure 8-3: Triple Counter Timer Block Diagram

8.5.3 Functional Description

Each prescaler module can be independently programmed to use the PS internal bus clock (CPU_1x), or an external clock from the MIO or the PL. For an external clock, SLCR registers determine the exact pinout through the MIO or from the PL. The selected clock is then divided down from /2 to /65536, before being applied to the counter.

The counter module can count up or count down, and can be configured to count for a given interval. It also compares three match registers to the counter value, and generate an interrupt if one matches.

The interrupt module combines interrupts of various types: counter interval, counter matches, counter overflow, event timer overflow. Each type can be individually enabled.

Modes of Operation

Each counter module can be independently programmed to operate in either of the following two modes:

Interval mode: The counter increments or decrements continuously between 0 and the value of the Interval register, with the direction of counting determined by the DEC bit of the Counter Control register. An interval interrupt is generated when the counter passes through zero. The corresponding match interrupt is generated when the counter value equals one of the Match registers.

Overflow mode: The counter increments or decrements continuously between 0 and 0xFFFF, with the direction of counting determined by the DEC bit of the Counter Control register. An overflow interrupt is generated when the counter passes through zero. The corresponding match interrupt is generated when the counter value equals one of the Match registers.

Event Timer Operation

The event timer operates by having an internal (invisible to users) 16-bit counter clocked at CPU_1x which:

- Resets to 0 during the non-counting phase of the external pulse
- Increments during the counting phase of the external pulse

The Event Control Timer register controls the behavior of the internal counter:

- **E_En bit:** When 0, immediately resets the internal counter to 0, and stops incrementing
- **E_Lo bit:** Specifies the counting phase of the external pulse
- **E_Ov bit:** Specifies how to handle overflow at the internal counter (during the counting phase of the external pulse)
 - When 0: Overflow causes E_En to be 0 (see E_En bit description)
 - When 1: Overflow causes the internal counter to wrap around and continues incrementing
 - An interrupt is always generated (subject to further enabling through another register) when an overflow occurs.

The Event register is updated with the non-zero value of the internal counter at the end of the counting-phase of the external pulse; therefore, it shows the widths of the external pulse, measured in number of cycles of CPU_1x.

If the internal counter is reset to 0, due to overflow, during the counting phase of the external pulse, the Event register will not be updated and maintains the old value from the last non-overflowing counting operation.

8.5.4 Register Overview

A register overview of the TTC is provided in [Table 8-4](#).

Table 8-4: Triple Timer Counter Register Overview

| Function | Name | Overview |
|---------------|--------------------------|---|
| Clock control | Clock Control register | Controls prescaler, selects clock input, edge |
| | Counter Control register | Enables counter, sets mode of operation, sets up/down counting, enables matching, enables waveform output |
| Status | Counter Value register | Returns current counter value |

Table 8-4: Triple Timer Counter Register Overview (Cont'd)

| Function | Name | Overview |
|-----------------|--|---|
| Counter Control | Interval register | Sets interval value |
| | Match register 1 Match register 2 Match register 3 | Sets match values, total 3 |
| | Interrupt register | Shows current interrupt status |
| | Interrupt Enable register | Enable interrupts |
| Event | Event Control Timer register | Enable event timer, stop timer, sets phrase |
| | Event register | Shows width of external pulse |

8.5.5 Programming Model

Counter Enable Sequence

1. Select clock input source, set prescaler value (slcr.MIO_MUX_SEL registers, TTC Clock Control register). Ensure TTC is disabled (ttc.Counter_Control_x [DIS] = 1) before proceeding with this step.
2. Set interval value (Interval register). This step is optional, for interval mode only.
3. Set match value (Match registers). This step is optional, if matching is to be enabled.
4. Enable interrupt (Interrupt Enable register). This step is optional, if interrupt is to be enabled.
5. Enable/disable waveform output, enable/disable matching, set counting direction, set mode, enable counter (TTC Counter Control register). This step starts the counter.

Counter Stop Sequence

1. Read back the value of the Counter Control register.
2. Set DIS bit to 1, while keeping other bits.
3. Write back to Counter Control register.

Counter Restart Sequence

1. Read back the value of Counter Control register.
2. Set RST bit to 1, while keeping other bits.
3. Write back to Counter Control register.

Event Timer Enable Sequence

1. Select external pulse source (slcr.MIO_MUX_SEL registers). The width of the selected external pulse is measured in CPU_1x period.

2. Set overflow handling, select external pulse level, enable the event timer (Event Control Timer register). This step starts measuring the width of the selected level (High or Low) of the external pulse.
3. Enable interrupt (Interrupt Enable register). This step is optional, if interrupt is to be enabled.
4. Read the measured width (Event register). Note that the returned value is not correct when overflow happened. See the description for the E_Ov bit of the Event Control Timer register in section [8.5.3 Functional Description](#).

Interrupt Clear and Acknowledge Sequence

1. Read Interrupt register: All bits in the Interrupt register are cleared on read.

8.5.6 Clock Input Option for Counter/Timer

The following shows how the SoC selects the clock source for TTC0 counter/timer 0:

```
if slcr.MIO_PIN_19[6:0] is 1100000, use MIO pin 19
else if slcr.MIO_PIN_31[6:0] is 1100000, use MIO pin 31
else if slcr.MIO_PIN_43[6:0] is 1100000, use MIO pin 43
else use EMIOTTTC0CLKI0
```

TTC0 counter/timer 1 can use only EMIOTTTC0CLKI1.

TTC0 counter/timer 2 can use only EMIOTTTC0CLKI2.

The following shows how the SoC selects the clock source for TTC1 counter/timer 0:

```
if slcr.MIO_PIN_17[6:0] is 1100000, use MIO pin 17
else if slcr.MIO_PIN_29[6:0] is 1100000, use MIO pin 29
else if slcr.MIO_PIN_41[6:0] is 1100000, use MIO pin 41
else use EMIOTTTC1CLKI0
```

TTC1 counter/timer 1 can use only EMIOTTTC1CLKI1.

TTC1 counter/timer 2 can use only EMIOTTTC1CLKI2.



IMPORTANT: *When an MIO pin or EMIOTTTCxCLKIx is chosen to be the clock source, if the clock stops running, the corresponding Count Value register retains the old value, regardless of the fact that the clock has already stopped. Caution must be exercised in this case.*

8.6 I/O Signals

Timer I/O signals are identified in [Table 8-5](#). The MIO pins and any restrictions based on device version are shown in the MIO table in section [2.5.4 MIO-at-a-Glance Table](#).

There are two triple timer counters (TTC0 and TTC1) in the system. Each TTC has three sets of interface signals: clock in and wave out for counter/timers 0, 1, and 2.

For each triple timer counter, the signals for counter/timer 0 can be routed to the MIO using the MIO_PIN registers. If the clock in or wave out signal is not selected by the MIO_PIN register, then the signal is routed to EMIO by default.

The signals for counter/timers 1 and 2 are only available through the EMIO.

Table 8-5: TTC I/O Signals

| TTC | Timer Signal | I/O | MIO Pins | EMIO Signals | Controller Default Input Value |
|------|--------------------------|-----|------------|-----------------|--------------------------------|
| TTC0 | Counter/Timer 0 clock in | I | 19, 31, 43 | EMIOTTTC0CLKI0 | 0 |
| | Counter/Timer 0 wave out | O | 18, 30, 42 | EMIOTTTC0WAVEO0 | ~ |
| | Counter/Timer 1 clock in | I | N/A | EMIOTTTC0CLKI1 | 0 |
| | Counter/Timer 1 wave out | O | N/A | EMIOTTTC0WAVEO1 | ~ |
| | Counter/Timer 2 clock in | I | N/A | EMIOTTTC0CLKI2 | 0 |
| | Counter/Timer 2 wave out | O | N/A | EMIOTTTC0WAVEO2 | ~ |
| TTC1 | Counter/Timer 0 clock in | I | 17, 29, 41 | EMIOTTTC1CLKI0 | 0 |
| | Counter/Timer 0 wave out | O | 16, 28, 40 | EMIOTTTC1WAVEO0 | ~ |
| | Counter/Timer 1 clock in | I | N/A | EMIOTTTC1CLKI1 | 0 |
| | Counter/Timer 1 wave out | O | N/A | EMIOTTTC1WAVEO1 | ~ |
| | Counter/Timer 2 clock in | I | N/A | EMIOTTTC1CLKI2 | 0 |
| | Counter/Timer 2 wave out | O | N/A | EMIOTTTC1WAVEO2 | ~ |

System watchdog timer I/O signals are identified in [Table 8-6](#).

Table 8-6: Watchdog Timer I/O Signals

| SWDT Signal | I/O | MIO Pins | EMIO Signals | Controller Default Input Value |
|-------------|-----|--------------------|--------------|--------------------------------|
| Clock in | I | 14, 26, 38, 50, 52 | EMIOWDTCCLKI | 0 |
| Reset out | O | 15, 27, 39, 51, 53 | EMIOWDTRSTO | ~ |

DMA Controller

9.1 Introduction

The DMA controller (DMAC) uses a 64-bit AXI master interface operating at the CPU_2x clock rate to perform DMA data transfers to/from system memories and PL peripherals. The transfers are controlled by the DMA instruction execution engine. The DMA engine runs on a small instruction set that provides a flexible method of specifying DMA transfers. This method provides greater flexibility than the capabilities of DMA controller methods.

The program code for the DMA engine is written by software in to a region of system memory that is accessed by the controller using its AXI master interface. The DMA engine instruction set includes instructions for DMA transfers and management instructions to control the system.

The controller can be configured with up to eight DMA channels. Each channel corresponds to a thread running on the DMA engine's processor. When a DMA thread executes a load or store instruction, the DMA Engine pushes the memory request to the relevant read or write queue. The DMA controller uses these queues to buffer AXI read/write transactions. The controller contains a multi-channel FIFO (MFIFO) to store data during the DMA transfers. The program code running on the DMA engine processor views the MFIFO as containing a set of variable-depth parallel FIFOs for DMA read and write transactions. The program code must manage the MFIFO so that the total depth of all of the DMA FIFOs does not exceed the 1,024-byte MFIFO.

The DMAC is able to move large amounts of data without processor intervention. The source and destination memory can be anywhere in the system (PS or PL). The memory map for the DMAC includes DDR, OCM, linear addressed Quad-SPI read memory, SMC memory and PL peripherals or memory attached to an M_GP_AXI interface.

The flow control method for transfers with PS memories use the AXI interconnect. Accesses with PL peripherals can use the AXI flow control or the DMAC's PL Peripheral Request Interface. There are no peripheral request interfaces directed to the PS I/O Peripherals (IOPs). For the PL peripheral AXI transactions, software running on a CPU is used in a programmed IO method using interrupts or status polling.

The controller has two sets of control and status registers. One set is accessible in secure mode and the other in non-secure mode. Software accesses these registers via the controller's 32-bit APB slave interface. The entire controller is either operated in secure or non-secure mode; there is no mixing of modes on a channel basis. Security configuration changes are controlled by slcr registers and require a controller reset to take effect.

9.1.1 Features

The DMA Controller provides:

- DMA Engine processor with a flexible instruction set for DMA transfers:
 - Flexible scatter-gather memory transfers
 - Full control over addressing for source and destination
 - Define AXI transaction attributes
 - Manage byte streams
- Eight cache lines and each cache line is four words wide
- Eight concurrent DMA channels threads
 - Allows multiple threads to execute in parallel
 - Issue commands for up to eight read and up to eight write AXI transactions
- Eight interrupts to the PS interrupt controller and the PL
- Eight events within DMA Engine program code
- 128 (64-bit) word MFIFO to buffer the data that the controller writes or reads during a transfer
- Security
 - Dedicated APB slave interface for secure register accessing
 - Entire controller is configured as either secure or non-secure
- Memory-to-memory DMA transfers
- Four PL peripheral request interfaces to manage flow control to and from the PL logic
 - Each interface accepts up to four active requests

9.1.2 System Viewpoint

The system viewpoint of the DMA controller is shown in Figure 9-1.

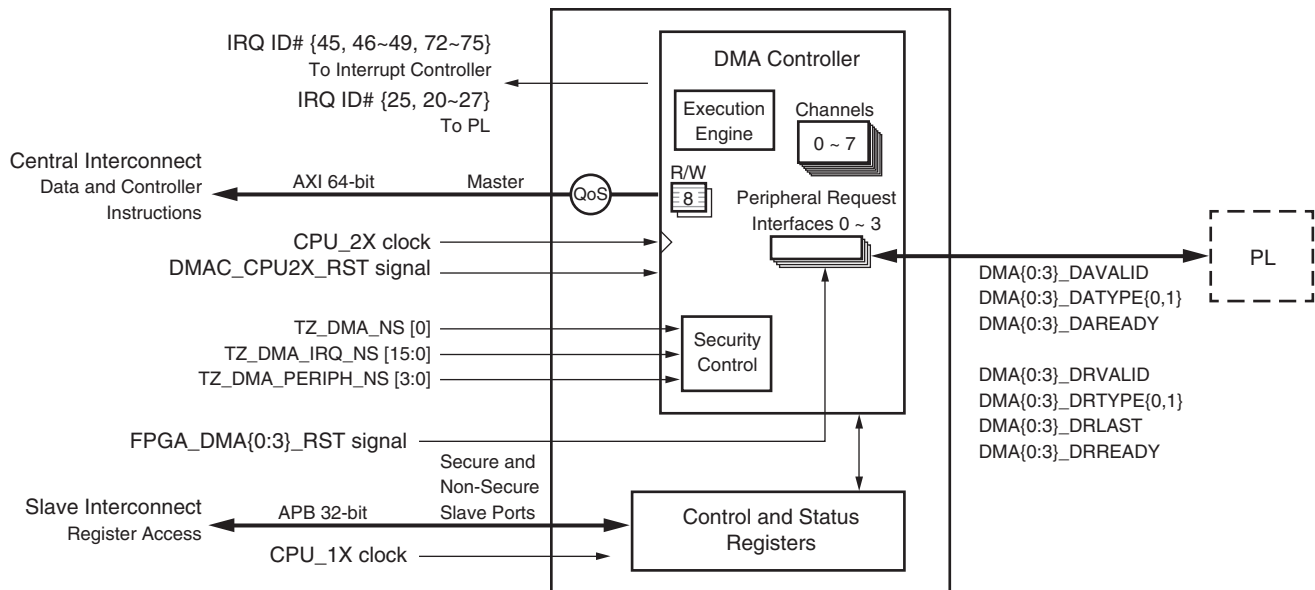

UG585_c9_01_021113

Figure 9-1: DMA Controller System Viewpoint

System Functions

The following system functions are described in section 9.6 System Functions:

- Clocks
- Resets and Reset Configuration

DMA Controller Functions and Programming

A block diagram for the DMA controller is shown in Figure 9-2. A brief description of each block follows the diagram. Each functional unit is described in detail in these three main sections:

- Overall description in section 9.2 Functional Description.
- SDK Software programming methods are in section 9.3 Programming Guide for DMA Controller.
- DMA Engine programming methods are in section 9.4 Programming Guide for DMA Engine.
- Programming restrictions for these methods are in section 9.5 Programming Restrictions:

9.1.3 Block Diagram

The block diagram of the DMA controller is shown in Figure 9-2.

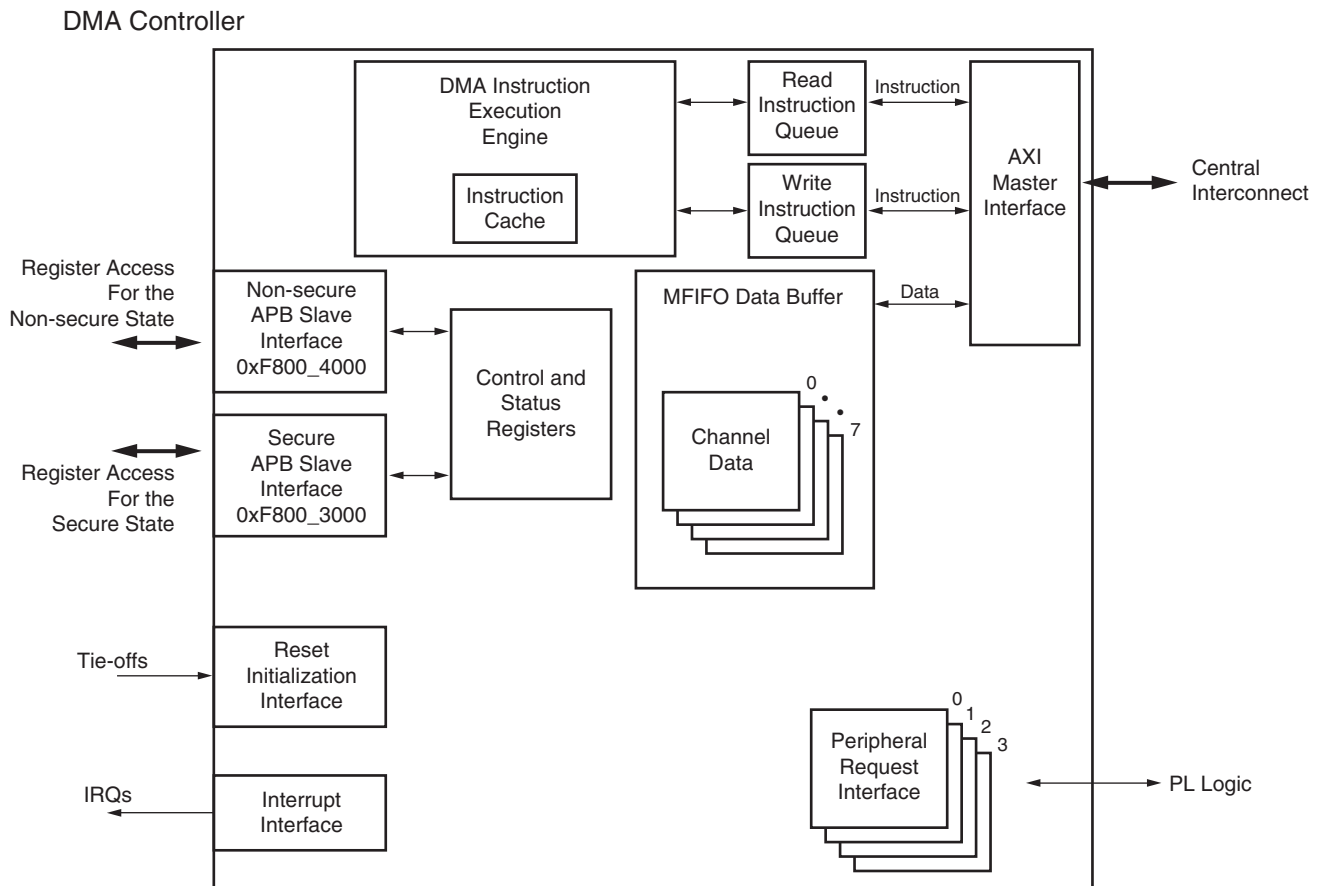

Figure 9-2: DMA Controller Block Diagram

Note: Refer to *Arm PrimeCell DMA Controller (PL330, r1p1) Technical Reference Manual: AXI Characteristics for a DMA Transfer and AXI Master* for more information.

DMA Instruction Execution Engine

The DMAC contains an instruction processing block that enables it to process program code that controls a DMA transfer. The DMAC maintains a separate state machine for each thread.

- Channel arbitration
 - Round-robin scheme to service the active DMA channels
 - Services the DMA manager prior of servicing the next DMA channel
 - Changes to the arbitration process are not supported
- Channel prioritization
 - Responds to all active DMA channels with equal priority
 - Changes to the priority of a DMA channel over any other DMA channels are not supported

Instruction Cache

The controller stores instructions temporarily in a cache. When a thread requests an instruction from an address, the cache performs a look-up. If a cache hit occurs then the cache immediately provides the data, otherwise the thread is stalled while the controller uses the AXI interface to perform a cache line fill from system memory. If an instruction is greater than four bytes, or spans the end of a cache line, then it performs multiple cache accesses to fetch the instruction.

Note: When a cache line fill is in progress, the controller enables other threads to access the cache, but if another cache miss occurs the pipeline is stalled until the first line fill is complete.

Note: Instruction cache latency for fill operations is dependent on the read latency of the system memory where the DMA engine instructions are written. The performance of the DMAC is highly dependent on the bandwidth of the 64-bit AXI master interface (CPU_2x clock).

Read/Write Instruction Queues

When a channel thread executes a load or store instruction the controller adds the instruction to the relevant read queue or write queue. The controller uses these queues as an instruction storage buffer prior to issuing transactions on the AXI interconnect.

Multi-channel Data FIFO

The DMAC uses a multi-channel first-in-first-out (MFIFO) data buffer to store data that it reads, or writes, during a DMA transfer. Refer to [9.2.4 Multi-channel Data FIFO \(MFIFO\)](#) for more information.

AXI Master Interface for Instruction Fetch and DMA Transfers

The program code is stored in a region of system memory that the controller accesses using the 64-bit AXI master interface. The AXI master interface also enables the DMA to transfer data from a source AXI slave to a destination AXI slave.

APB Slave Interface for Register Accesses

The controller responds to two address ranges used by software to read and write the control and status registers via the 32-bit APB slave interface.

- Non-secure register accesses
- Secure register accesses

Interrupt Interface

The interrupt interface enables efficient communications of events to the interrupt controller.

PL Peripheral DMA Request Interface

The PL peripheral request interface supports the connection of DMA-capable peripherals resident in the PL. Each PL peripheral request interface is asynchronous to one another and asynchronous to the

DMA itself. The request/acknowledge signals to and from the PL are described in section [9.2.6 PL Peripheral AXI Transactions](#).

Reset Initialization Interface

This interface enables the software to initialize the operating state of the DMAC as it exits from reset. Refer to section [9.6.3 Reset Configuration of Controller](#) for more information.

9.1.4 Notices

Arm IP Core

The DMAC is an Advanced Microcontroller Bus Architecture (AMBA) PrimeCell peripheral that is developed, tested, and licensed by Arm.

A list of the Arm Reference Documents for the DMA controller are summarized in [Appendix A, Additional Resources](#).

- **Technical Reference Manual:** *Arm PrimeCell DMA Controller (PL330) Technical Reference Manual*.
- **Example Application Notes:** *Arm Application Note 239: Example programs for the CoreLink DMA Controller DMA-330* and refer to [9.4 Programming Guide for DMA Engine](#).

Secure/Non-Secure Modes

The DMAC includes features to enable it to co-exist with Arm's TrustZone hardware to accelerate the performance of secure systems. The hardware is not required to ensure a secure environment. This chapter includes many references to secure and non-secure modes. It may not be complete. For additional information related to the use of the DMA PL330 controller with Arm TrustZone, refer to UG1019, *Programming ARM TrustZone Architecture on the Zynq-7000 SoC*.

Other DMA Controllers

There are other DMA controllers in the system that are local to the IOPs in the PS. These include:

- GigE controller, refer to [Chapter 16, Gigabit Ethernet Controller](#).
- SDIO controller, refer to [Chapter 13, SD/SDIO Controller](#).
- USB controller, refer to [Chapter 15, USB Host, Device, and OTG Controller](#).
- DevC Interface, refer to section [6.4 Device Boot and PL Configuration](#).

9.2 Functional Description

Common to all DMAC operating conditions

- [9.2.1 DMA Transfers on the AXI Interconnect](#)
- [9.2.2 AXI Transaction Considerations](#)
- [9.2.3 DMA Manager](#)
- [9.2.4 Multi-channel Data FIFO \(MFIFO\)](#)

Memory-to-memory transfers are managed by the DMAC

- [9.2.5 Memory-to-Memory Transfers](#)

When the PL Peripheral Request Interface is used

- [9.2.6 PL Peripheral AXI Transactions](#)
- Length management option: [9.2.8 PL Peripheral - Length Managed by PL Peripheral](#)
- Length management option: [9.2.9 PL Peripheral - Length Managed by DMAC](#)

Advanced DMAC operating features

- [9.2.10 Events and Interrupts](#)
- [9.2.11 Aborts](#)
- [9.2.12 Security](#)

IP core Configuration

- Based on the *Arm PrimeCell DMA Controller (PL330)* refer to [9.2.13 IP Configuration Options](#)

9.2.1 DMA Transfers on the AXI Interconnect

All of the DMA transactions use AXI interfaces to move data between the on-chip memory, DDR memory and slave peripherals in the PL. The slave peripherals in the PL normally connect to the DMAC peripheral request interface to control data flow. The DMAC can conceivably access IOPs in the PS, but this is normally not useful because these paths offer no flow control signals.

The data paths that are normally used by the DMAC are shown in [Figure 9-3](#). The peripheral request interface (used for flow control) is not shown in the figure. Each AXI path can be a read or write. There are many combinations. Two typical DMA transaction examples include:

- Memory to memory (On-chip memory to DDR memory)
- Memory to/from PL peripheral (DDR memory to PL peripheral)

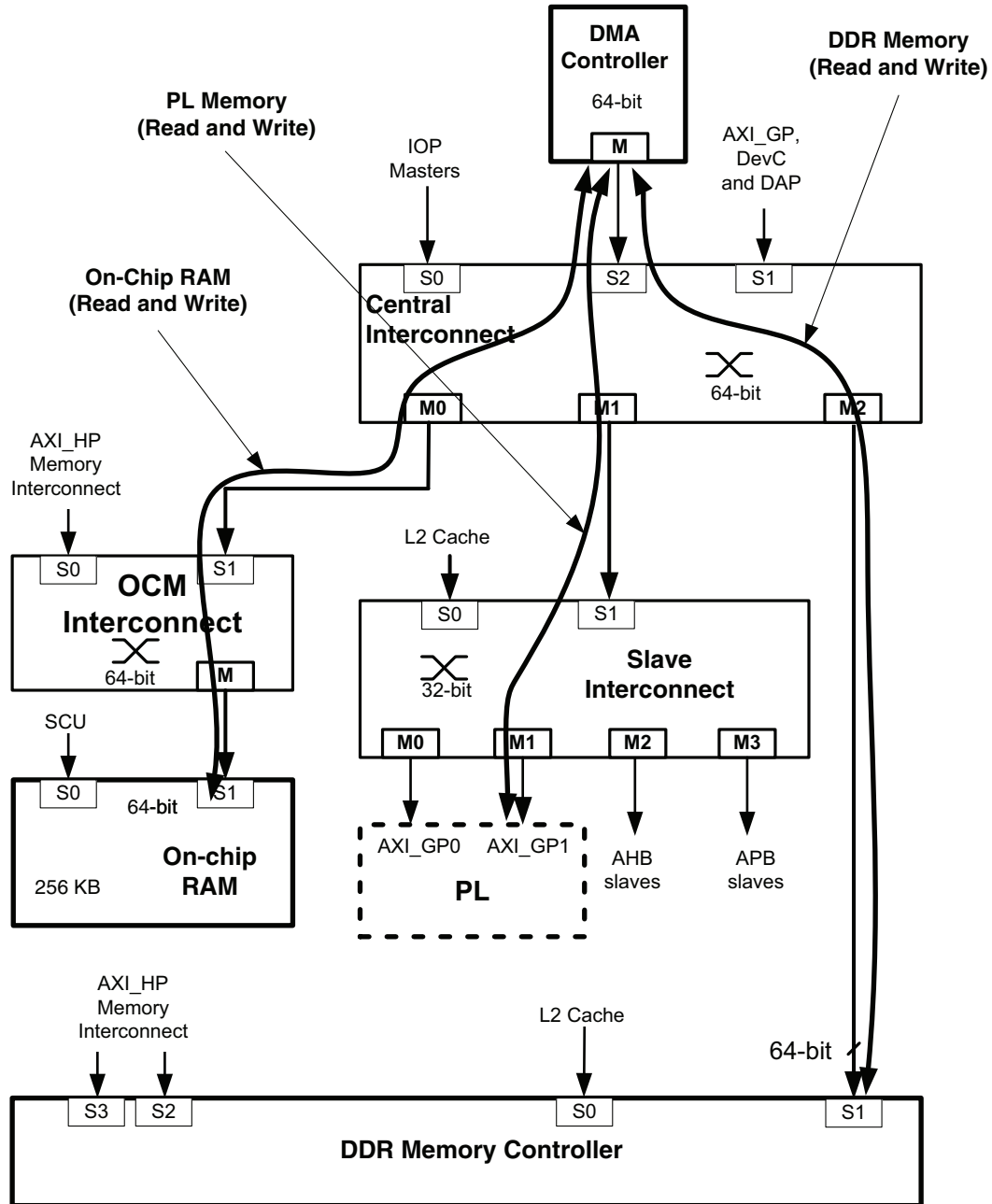

UG585_c9_07_021113

Figure 9-3: DMAC Reads/Writes DDR, On-chip RAM, and PL Peripheral

9.2.2 AXI Transaction Considerations

- AXI data transfer size
 - Performs data accesses up to the 64-bit width of the AXI data bus
 - Signals a precise abort if the user programs the `src_burst_size` or `dst_burst_size` fields to be larger than 64 bits
 - Maximum burst length is 16 data beats
- AXI bursts crossing 4 KB boundaries
 - The AXI specification does not permit AXI bursts to cross 4 KB address boundaries
 - If the controller is programmed with a combination of burst start address, size, and length that would cause a single burst to cross a 4 KB address boundary, then the controller instead generates a pair of bursts with a combined length equal to that specified. This operation is transparent to the DMAC channel thread program so that, for example, the DMAC responds to a single DMALD instruction by generating the appropriate pair of AXI read bursts.
- AXI burst types
 - Can be programmed to generate only fixed-address or incrementing-address burst types for data accesses. Wrapping-address bursts are not generated for data accesses or for instruction fetches.
- AXI write addresses
 - Can issue multiple outstanding write addresses up to eight (write issuing capability)
 - The DMAC does not issue a write address until it has read in all of the data bytes required to fulfill that write transaction.
- AXI write data interleaving
 - Does not generate interleaved write data. All write data beats for one write transaction are output before any write data beat for the next write transaction.
- AXI characteristics
 - Does not support locked or exclusive accesses

9.2.3 DMA Manager

This section describes how to issue instructions to the DMA manager using one of the two APB interfaces available.

When the DMAC is operating in real time, the user can only issue the following limited subset of instructions:

| | |
|---------|--|
| DMAGO | Starts a DMA transfer using a DMA channel that the user specifies. |
| DMASEV | Signals the occurrence of an event, or interrupt, using an event number that the user specifies. |
| DMAKILL | Terminates a thread. |

The appropriate APB interface must be used depending on the security state in which the SLCR register TZ_DMA_NS initializes the DMA manager to operate. For example, if the DMA manager is in the secure state, the instruction using the secure APB interface must be used or the DMAC ignores the instruction. The non-secure APB interface is the suggested port to use to start or restart a DMA channel when the DMA manager is in the non-secure state, however, the secure APB interface can be used in non-secure mode. (Refer to section 9.2.12 Security for more details.) For additional information related to the use of the DMA PL330 controller with Arm TrustZone, refer to UG1019, *Programming ARM TrustZone Architecture on the Zynq-7000 SoC*.

Before issuing instructions using the Debug Instruction registers or the DBGCMD register, the DBGSTATUS register must be read to ensure that debug is idle, otherwise, the DMA manager ignores the instructions. Refer to the Debug Command register and Debug Status register in [Appendix B, Register Details](#).

When the DMA manager receives an instruction from an APB slave interface, it can take several clock cycles before it can process the instruction — for example, if the pipeline is busy processing another instruction.

Prior to issuing DMAGO, the system memory must contain a suitable program for the DMA channel thread to execute, starting at the address that the DMAGO specifies.

Example: Start DMA Channel Thread

The following example shows the steps required to start a DMA channel thread using the debug instruction registers.

1. Create a program for the DMA channel.
2. Store the program in a region of system memory.

Use one of the APB interfaces on the DMAC to program a DMAGO instruction as follows:

3. Poll the dmac.DBGSTATUS register to ensure that debug is idle, that is, the dbgstatus bit is 0. Refer to the Debug Status register in [Appendix B, Register Details](#).
4. Write to the dmac.DBGINST0 register and enter the:
 - a. Instruction byte 0 encoding for DMAGO.
 - b. Instruction byte 1 encoding for DMAGO.
 - c. Debug thread bit to 0. This selects the DMA manager. Refer to the Debug Instruction-0 register in [Appendix B, Register Details](#).
5. Write to the dmac.DBGINST1 register with the DMAGO instruction byte [5:2] data, refer to the Debug Instruction-1 register in [Appendix B, Register Details](#). These four bytes must be set to the address of the first instruction in the program that was written to system memory in Step 2.

Instruct the DMAC to execute the instruction that the debug instruction registers contain:

6. Write a 0 to the dmac.DBGCMD register. The DMAC starts the DMA channel thread and sets the dbgstatus bit to 1. Refer to the Debug Command register in [Appendix B, Register Details](#). After the DMAC completes execution of the instruction, it clears the dbgstatus bit to 0.

9.2.4 Multi-channel Data FIFO (MFIFO)

The MFIFO is a shared resource utilized on a first-come, first-served basis by all currently active channels. To a program, it appears as a set of variable-depth parallel FIFOs, one per channel, with the restriction that the total depth of all the FIFOs cannot exceed the size of the MFIFO. The DMAC maximum MFIFO depth is 128 (64-bit) words.

The controller is capable of realigning data from the source to the destination. For example, the DMAC shifts the data by two byte lanes when it reads a word from address `0x103` and writes to address `0x205`. The storage and packing of the data in the MFIFO is determined by the destination address and transfer characteristics.

When a program specifies that incrementing memory transfers are to be performed to the destination, the DMAC packs data into the MFIFO to minimize the usage of the MFIFO entries. For example, the DMAC packs two 32-bit words into a single entry in the MFIFO when the DMAC has a 64-bit AXI data bus and the program uses a source address of `0x100`, and destination address of `0x200`.

In certain situations, the number of entries required to store the data loaded from a source is not a simple calculation of the amount of source data divided by MFIFO width. The calculation of the number of entries required is not simple when any of the following occur:

- Source address is not aligned to the AXI bus width
- Destination address is not aligned to the AXI bus width
- Memory transfers are to a fixed destination, that is, a non-incrementing address

The DMALD and DMAST instructions each specify that an AXI bus transaction is to be performed. The amount of data transferred by an AXI bus transaction depends on the values programmed in to the CCRn register and the address of the transaction. Refer to the *AMBA AXI Protocol Specification* for information about unaligned transfers.

Refer to section [9.3 Programming Guide for DMA Controller](#) for considerations about MFIFO utilization.

9.2.5 Memory-to-Memory Transfers

The controller includes an AXI master interface to access memories in the PS system, such as:

- OCM
- DDR

Through the same AXI central interconnect, the controller can potentially access the majority of the peripheral subsystems. If a target peripheral can be seen as a memory-mapped region (or memory port location) without a FIFO or need for flow control, then the DMAC can be used to read and write to it. Typical examples include:

- QSPI in Linear addressing mode
- NOR flash
- NAND flash

The memory map for the DMA controller is shown in [Chapter 4, System Addresses](#).

For more information on the AXI Interfaces, refer to . Examples of memory-to-memory transfer are provided in section [9.4.2 Memory-to-Memory Transfers](#).

9.2.6 PL Peripheral AXI Transactions

The majority of PL peripherals allow transferring data through FIFOs. These FIFOs must be managed to avoid overflow and underflow situations. For this reason, four specific peripheral request interfaces are available to connect the DMAC to DMA-capable peripherals in the PL. Each one of these interfaces can be assigned to any DMA channel.

The DMAC is configured to accept up to four active requests for each PL peripheral interface. An active request is where the DMAC has not started the requested AXI data transaction. The DMAC has a request FIFO for each PL peripheral interface, which it uses to capture the requests from a PL peripheral. When a request FIFO is full, the DMAC sets the corresponding DMA{3:0}_DRREADY Low to signal that the DMAC cannot accept any requests sent from the PL peripheral.

Note: There are no peripheral request interfaces directed to the I/O peripherals (IOP) in the PS. Processor intervention is needed to avoid underflow or overflow of the FIFOs in the targeted PS peripheral. This section discusses the AXI transactions to/from PL peripherals.

There are two different way to handle the quantity of data flowing between the DMAC and the PL peripheral:

| | |
|----------------------------------|---|
| PL Peripheral length management: | The PL peripheral controls the quantity of data that is contained in a DMA cycle. |
| DMAC length management: | The DMAC is controlling the quantity of data in a DMA cycle. |

Programming Examples

Refer to section [9.4.3 PL Peripheral DMA Transfer Length Management](#).

9.2.7 PL Peripheral Request Interface

[Figure 9-4](#) shows that the PL peripheral request interface consists of a PL peripheral request bus and a DMAC acknowledge bus that use the prefixes:

| | |
|----|---------------------------|
| DR | PL Peripheral request bus |
| DA | DMAC acknowledge bus |

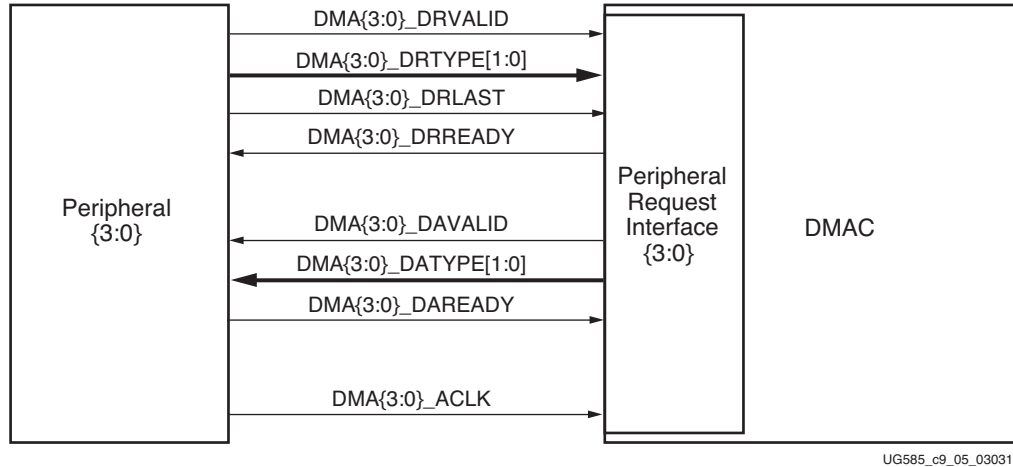

Figure 9-4: DMAC PL Peripheral Request Interface Request/Acknowledge Signals

Both buses use the valid-ready handshake that the AXI protocol describes. For more information on the handshake process, refer to the *AMBA AXI Protocol v1.0 Specification*.

The PL peripheral uses the DMA{3:0}_DRTYPE[1:0] registers to:

- Request a single AXI transaction
- Request a AXI burst transaction
- Acknowledge a flush request

The DMAC uses the DMA{3:0}_DATYPE[1:0] registers to:

- Signal when it completes the requested single AXI transaction
- Signal when it completes the requested AXI burst transaction
- Issue a flush request

The PL peripheral uses DMA{3:0}_DRLAST to:

- Signal to the DMAC when the last data cycle of the AXI transaction commences

Handshake Rules

The DMAC uses the DMA handshake rules that Table 9-1 shows, when a DMA channel thread is active, that is, not in the stopped state. Refer to the Figure 9-5, page 266 for more information.

Table 9-1: DMAC PL Peripheral Request Interface Handshake Rules

| Rule | Description ⁽¹⁾ |
|------|--|
| 1 | DMA{3:0}_DRVALID can change from Low to High on any DMA{3:0}_ACLK cycle, but must only change from High to Low when DMA{3:0}_DRREADY is High. |
| 2 | DMA{3:0}_DRTYPE can only change when either: <ul style="list-style-type: none"> • DMA{3:0}_DRREADY is High • DMA{3:0}_DRVALID is Low |

Table 9-1: DMAC PL Peripheral Request Interface Handshake Rules (Cont'd)

| Rule | Description ⁽¹⁾ |
|------|--|
| 3 | DMA{3:0}_DRLAST can only change when either: <ul style="list-style-type: none"> • DMA{3:0}_DRREADY is High • DMA{3:0}_DRVALID is Low |
| 4 | DMA{3:0}_DAVALID can change from Low to High on any DMA{3:0}_ACLK cycle, but must only change from High to Low when DMA{3:0}_DAREADY is High |
| 5 | DMA{3:0}_DATYPE can only change when either: <ul style="list-style-type: none"> • DMA{3:0}_DAREADY is High • DMA{3:0}_DAVALID is Low |

Notes:

1. All signals are synchronous to the DMA{3:0}_ACLK clock.

Map PL Peripheral Interface to a DMA Channel

The DMAC enables software to assign a PL peripheral request interface to any of the DMA channels. When a DMA channel thread executes DMAWFP, the value programmed in the PL peripheral [4:0] field specifies the PL peripheral associated with that DMA channel. Refer to the DMAWFP instruction in Table 9-8, page 274.

PL Peripheral Request Interface Timing Diagram

Figure 9-5 shows an example of the functional operation of the PL peripheral request interface using the rules that handshake rules described, when a PL peripheral requests an AXI burst transaction.

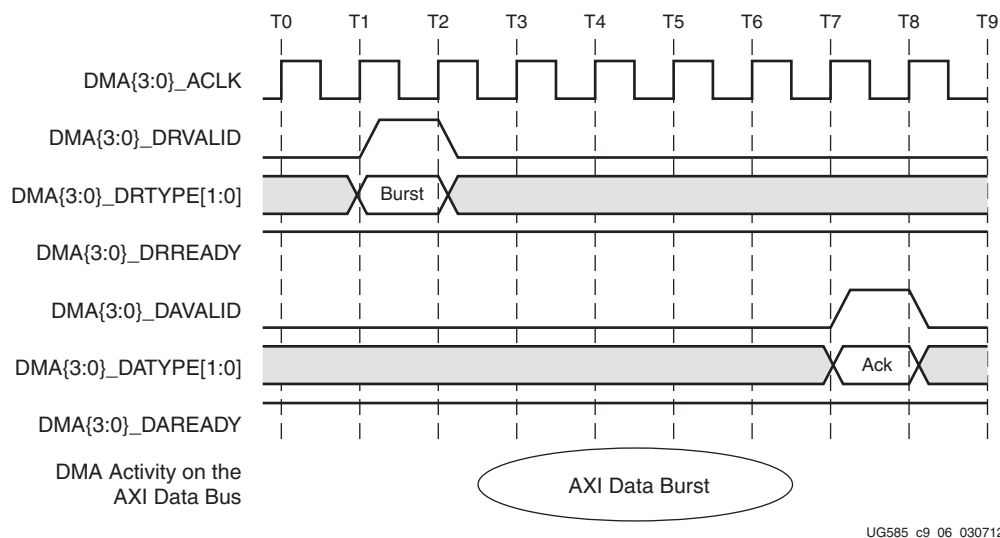

Figure 9-5: DMAC PL Peripheral Request Interface Burst Request Signaling

State transitions in Figure 9-5:

- T1 The DMAC detects a request for an AXI burst transaction.
- Between T2 and T7 The DMAC performs the AXI burst transaction.

| | |
|----|---|
| T7 | The DMAC sets DMA{3:0}_DAVALID High and sets DMA{3:0}_DATYPE[1:0] to indicate that the transaction is complete. |
|----|---|

For more timing diagrams refer to *Arm PrimeCell DMA Controller (PL330) Technical Reference Manual: Peripheral Request Interface Timing Diagrams*, keeping in mind that each PL peripheral request interface is asynchronous to one another and asynchronous to the DMA itself.

9.2.8 PL Peripheral - Length Managed by PL Peripheral

The PL peripheral request interface enables a PL peripheral to control the quantity of data that an AXI transfer contains, without the DMAC being aware of how many data cycles the transfer contains. The PL peripheral controls the AXI transaction by using:

| | |
|----------------------|---|
| DMA{3:0}_DRTYPE[1:0] | Selects a single or burst AXI Transaction |
| DMA{3:0}_DRLAST | Notifies the DMAC when it commences the final request in the current series |

When the DMAC executes a DMAWFP instruction, it halts execution of the thread and waits for the PL peripheral to send a request. When the PL peripheral sends the request, the DMAC sets the state of the request flags depending on the state of the following signals:

| | |
|----------------------|---|
| DMA{3:0}_DRTYPE[1:0] | The DMAC sets the state of the request_type flag: |
| 00: | request_type = Single |
| 01: | request_type = Burst |
| DMA{3:0}_DRLAST | The DMAC sets the state of the request_last flag: |
| 0: | request_last = 0 |
| 1: | request_last = 1 |

If the DMAC executes a DMAWFP single or DMAWFP burst instruction then the DMAC sets:

- The request_type{3:0} flag to Single or Burst, respectively
- The request_last{3:0} flag to 0

DMALPFE is an assembler directive which forces the associated DMALPEND instruction to have its nf bit set to 0. This creates a program loop that does not use a loop counter to terminate the loop. The DMAC exits the loop when the request_last flag is set to 1.

The DMAC conditionally executes the following instructions, depending on the state of the request_type and request_last flags:

DMALD, DMAST, DMALPEND

When these instructions use the optional B|S suffix then the DMAC executes a DMANOP if the request_type flag does not match.

DMALDP<B|S>, DMASTP<B|S>

The DMAC executes a DMANOP if the request_type flag does not match the B|S suffix.

DMALPEND

When the nf bit is 0, the DMAC executes a DMANOP if the request_last flag is set.

The DMALDB, DMALDPB, DMASTB and DMASTPB instructions should be used if the DMAC is required to issue an AXI burst transaction when the DMAC receives a burst request, that is, when DMA{3:0}_DRTYPE[1:0] = b01. The values in the CCRn register control the amount of data in the DMA transfer. Refer to the Channel Control registers in [Appendix B, Register Details](#).

The DMALDS, DMALDPS, DMASTS, and DMASTPS instructions should be used if the DMAC is required to issue a single AXI transaction when the DMAC receives a single request, that is, when DMA{3:0}_DRTYPE[1:0] = b00. The DMAC ignores the value of the src_burst_len and dst_burst_len fields in the CCRn register and sets the arlen[3:0] or awlen[3:0] buses to 0x0.

Refer to the [Programming Guide for DMA Controller](#) for an example of microcode for PL peripheral length management.

9.2.9 PL Peripheral - Length Managed by DMAC

DMAC length management is the process by which the DMAC controls the total amount of data to transfer. Using the PL peripheral request interface, the PL peripheral notifies the DMAC when a transfer of data in either direction is required. The DMA channel thread controls how the DMAC responds to the PL peripheral requests.

The following constraints apply to DMAC length management:

- The total quantity of data for all of the single requests from a PL peripheral must be less than the quantity of data for a burst request for that PL peripheral.
- The CCRn register controls how much data is transferred for a burst request and a single request. Arm recommends that a CCRn register not be updated while a transfer is in progress for that channel. Refer to the Channel Control registers in [Appendix B, Register Details](#).
- After the PL peripheral sends a burst request, the PL peripheral must not send a single request until the DMAC acknowledges that the burst request is complete.

The DMAWFP single instruction should be used when the program thread is required to halt execution until the PL peripheral request interface receives any request type. If the head entry request type in the request FIFO is:

Single: The DMAC pops the entry from the FIFO and continues program execution.

Burst: The DMAC leaves the entry in the FIFO and continues program execution.

Note: The burst request entry remains in the request FIFO until the DMAC executes a DMAWFP burst instruction or a DMAFLUSHP instruction.

The DMAWFP burst instruction should be used when the program thread is required to halt execution until the PL peripheral request interface receives a burst request. If the head entry request type in the request FIFO is:

- Single: The DMAC removes the entry from the FIFO and program execution remains halted.
- Burst: The DMAC pops the entry from the FIFO and continues program execution.

The DMALDP instruction should be used when the DMAC is required to send an acknowledgement to the PL peripheral when it completes the AXI read transaction. Similarly, the DMASTP instruction should be used when the DMAC is required to send an acknowledgement to the PL peripheral when it completes the AXI write transaction. The DMAC uses the DMA{3:0}_DATYPE[1:0] bus to acknowledge the transaction to the PL peripheral {3:0}.

The DMAC sends an acknowledgement for a read transaction when rvalid and rlast are High and for a write transaction when bvalid is High. If the system is able to buffer AXI write transactions, it might be possible for the DMAC to send an acknowledgement to the PL peripheral, but the transaction of write data to the end destination is still in progress.

The DMAFLUSHP instruction should be used to reset the request FIFO for the PL peripheral request interface. After the DMAC executes DMAFLUSHP, it ignores PL peripheral requests until the PL peripheral acknowledges the flush request. This enables the DMAC and PL peripheral to synchronize with each other.

Refer to section 9.3 Programming Guide for DMA Controller for an example of microcode for DMA length management.

9.2.10 Events and Interrupts

The DMAC supports 16 events. The first 8 of these events can be interrupt signals, IRQs [7:0]. Each of the eight interrupts are outputs going to both the PS interrupt controller and the PL at the same time. The events are used internal to the DMA engine to cross-trigger channel-to-channel or manager-to-channel.

Table 9-2 shows the mapping between events and interrupts. Refer to the Interrupt Enable register in Appendix B, Register Details for programming details.

Table 9-2: DMAC Events and Interrupts

| DMAC Event/IRQ # | System IRQ# (to the PS) | IRQP2F (to the PL) | DMA Engine Event# |
|------------------|-------------------------|--------------------|-------------------|
| 0 ~ 3 | 46 ~ 49 | 20 ~ 23 | 0 ~ 3 |
| 4 ~ 7 | 72 ~ 75 | 24 ~ 27 | 4 ~ 7 |
| 8 ~ 15 | na | na | 8 ~ 15 |

When the DMA engine executes a DMASEV instruction it modifies the event/interrupt that the user specifies.

- If the INTEN register sets the event/interrupt resource to function as an event, the DMAC generates an event for the specified event/interrupt resource. When the DMAC executes a DMAWFE instruction for the same event-interrupt resource then it clears the event.

- If the INTEN register sets the event/interrupt resource to function as an interrupt, the DMAC sets irq<event_num> High, where event_num is the number of the specified event-resource. To clear the interrupt, the user must write to the INTCLR register. Refer to the Interrupt Clear register in [Appendix B, Register Details](#).

Refer to section [9.3 Programming Guide for DMA Controller](#) for more information and [Chapter 7, Interrupts](#) for more details about the System IRQs.

9.2.11 Aborts

An abort is sent to the CPUs via IRQ ID #45 and the PL peripheral via the IRQP2F[28] signal. [Table 9-3](#) summarizes all of the possible causes for an abort. [Table 9-3](#) explains the actions that the DMAC takes after an abort condition. After an abort occurs the action the DMAC takes depends on the thread type. [Table 9-5](#) describes the actions that the processors or the PL peripheral must take after the Abort signal is received. Refer to the *Arm PrimeCell DMA Controller (PL330) Technical Reference Manual: Aborts* for details.

Table 9-3: DMAC Abort Types and Conditions

| Abort Types | Condition |
|---|---|
| <p>Precise</p> <p>The DMAC updates the PC register with the address of the instruction that created the abort.</p> <p>Note: When the DMAC signals a precise abort, the instruction that triggers the abort is not executed; the DMAC executes a DMANOP instead.</p> | <p>Security Violation on Channel Control Registers</p> <p>A DMA channel thread in a non-secure state attempts to program the Channel Control registers and generates a secure AXI bus transaction.</p> |
| | <p>Security Violation on Events</p> <p>A DMA channel thread in a non-secure state executes DMAWFE or DMASEV for an event that is set as secure. The SLCR register TZ_DMA_IRQ_NS controls the security state for an event.</p> |
| | <p>Security Violation on PL Peripheral Request Interfaces</p> <p>A DMA channel thread in a non-secure state executes DMAWFP, DMALDP, DMASTP, or DMAFLUSHP for a PL peripheral request interface that is set as secure. The SLCR register TZ_DMA_PERIPH_NS controls the security state for a PL peripheral request interface.</p> |
| | <p>Security Violation on DMAGO</p> <p>The DMA manager in a non-secure state executes DMAGO to attempt to start a secure DMA channel thread.</p> |
| | <p>Error on AXI Master Interface</p> <p>The DMAC receives an ERROR response on the AXI master interface when it performs an instruction fetch. For example; trying to access reserved memory.</p> |
| | <p>Error on Execution Engine</p> <p>A thread executes an undefined instruction or executes an instruction with an operand that is invalid for the configuration of the DMAC.</p> |

Table 9-3: DMAC Abort Types and Conditions (Cont'd)

| Abort Types | Condition |
|---|--|
| <p>Imprecise The PC register might contain the address of an instruction that did not cause the abort occur.</p> | <p>Error on Data Load The DMAC receives an ERROR response on the AXI master interface when it performs a data load.</p> |
| | <p>Error on Data Store The DMAC receives an ERROR response on the AXI master interface when it performs a data store.</p> |
| | <p>Error on MFIFO A DMA channel thread executes DMALD and the MFIFO is too small to store the data or executes DMAST and the MFIFO contains insufficient data to complete the AXI transaction.</p> |
| | <p>Watchdog Abort The DMAC can lock up if one or more DMA channel programs are running and the MFIFO is too small to satisfy the storage requirements of the DMA programs. The DMAC contains logic to prevent it from remaining in a state where it is unable to complete a DMA transfer. The DMAC detects a lock up when all of the following conditions occur:</p> <ul style="list-style-type: none"> • Load queue is empty • Store queue is empty • All of the running channels are prevented from executing a DMALD instruction either because the MFIFO does not have sufficient free space or another channel owns the load-lock <p>When the DMAC detects a lock up it signals an interrupt and can also abort the contributing channels. The DMAC behavior depends on the state of the wd_irq_only bit in the WD register. For more information, refer to the subsection Resource Sharing Between DMA Channels, page 288.</p> |

Table 9-4: DMAC Abort Handling

| Thread Type | DMAC Actions |
|-----------------------|---|
| Channel thread | Sets IRQ#45 interrupt and IRQP2F[28] signal High |
| | Stops executing instructions for the DMA channel |
| | Invalidates all cache entries for the DMA channel |
| | Updates the Channel Program Counter registers to contain the address of the aborted instruction provided that the abort was precise |
| | Does not generate AXI accesses for any instructions remaining in the read queue and write queue |
| | Permits currently active AXI bus transactions to complete |
| DMA manager | Sets IRQ#45 interrupt and IRQP2F[28] signal High |

Table 9-5: DMAC Thread Termination

| Processor or PL Peripheral Actions |
|---|
| Reads the status of Fault Status DMA Manager register to determine if the DMA manager is faulting and to determine the cause of the abort |
| Reads the status of Fault Status DMA Channel register to determine if a DMA channel is faulting and to determine the cause of the abort |

Table 9-5: DMAC Thread Termination (Cont'd)

| Processor or PL Peripheral Actions |
|---|
| Programs the Debug Instruction-0 register with the encoding for the DMAKILL instruction |
| Writes to the Debug Command register. |

9.2.12 Security

When the DMAC exits from reset, the status of the reset initialization interface signals configures the security for the:

- DMA manager (SLCR register TZ_DMA_NS)
- Event/Interrupt resources (SLCR register TZ_DMA_IRQ_NS)
- PL peripheral request interfaces (SLCR register TZ_DMA_PERIPH_NS)

Refer to the section [9.6.3 Reset Configuration of Controller](#) for more details.

When the DMA manager executes a DMAGO instruction for a DMA, it sets the security state of the channel by setting the ns bit. The status of the channel is provided by the dynamic non-secure bit, CNS in the Channel Status register.

Note: For more information refer to UG1019, *Programming ARM TrustZone Architecture on the Zynq-7000 SoC*.

Nomenclature

Table 9-6 describes how the nomenclature used in this chapter corresponds to Arm nomenclature.

Table 9-6: DMAC Security Nomenclature

| Arm Name | XILINX Name | Description |
|----------|---------------------------------------|---|
| DNS | DMAC_NS in TZ_DMA_NS | <p>DMA Non-secure</p> <p>When the DMAC exits from reset, this signal controls the security state of the DMA manager:</p> <p>0: DMA manager operates in the secure state</p> <p>1: DMA manager operates in the non-secure state</p> |
| INS | DMAC_IRQ_NS<x> in TZ_DMA_IRQ_NS | <p>Interrupt Non-secure</p> <p>When the DMAC exits from reset, this signal controls the security state of an event/interrupt:</p> <p>0: DMAC interrupt/event bit is in the secure state</p> <p>1: DMAC interrupt/event bit is in the non-secure state</p> |
| PNS | DMAC_PERIPH_NS<x> in TZ_DMA_PERIPH_NS | <p>PL Peripheral Non-secure</p> <p>When the DMAC exits from reset, this signal controls the security state of a PL peripheral request interface:</p> <p>0: DMAC PL peripheral request interface is in the secure state</p> <p>1: DMAC PL peripheral request interface is in the non-secure state</p> |

Table 9-6: DMAC Security Nomenclature (Cont'd)

| Arm Name | XILINX Name | Description |
|----------|-------------------------|--|
| ns | ns in DMAGO instruction | DMAGO Non-secure Bit 1 of the DMAGO instruction: 0: DMA channel thread starts in the secure state 1: DMA channel thread starts in the secure state |
| CNS | CNS in CSR<x> | CHANNEL Non-secure The security state of each DMA channel is provided by bit CNS in the Channel Status register: 0: DMA channel thread operates in the secure state 1: DMA channel thread operates in the secure state |

Security by DMA Manager

A quick summary of the security usage for the DMA Manager is given in [Table 9-7](#).

Table 9-7: DMAC Security by DMA Manager

| | DNS | Instruction | ns | INS | Description |
|--------------------|-----|-------------|----|-----|---|
| DMA Manager | 0 | DMAGO | 0 | - | The instruction must be issued using the secure APB interface. The DMA channel thread starts in secure state (CNS= 0). |
| | | | 1 | - | The instruction must be issued using the secure APB interface. The DMA channel thread starts in non-secure state (CNS=1). |
| | | DMASEV | - | X | The instruction must be issued using the secure APB interface. It signals the appropriate event irrespective of the INS bit. |
| | 1 | DMAGO | 0 | - | The instruction must be issued using the non-secure APB interface. Abort (see section 9.2.11 Aborts). |
| | | | 1 | - | The instruction must be issued using the non-secure APB interface. The DMA channel thread starts in non-secure state (CNS=1). |
| | | DMASEV | - | 0 | The instruction must be issued using the non-secure APB interface. Abort (see section 9.2.11 Aborts). |
| | | | - | 1 | The instruction must be issued using the non-secure APB interface. It signals the appropriate event. |

Security by DMA Channel Thread

A quick summary of the security usage for the DMA Channel Threads is given in [Table 9-8](#).

Table 9-8: DMAC Security by DMA Channel Thread

| | CNS bit | Instruction | PNS bit | INS bit | Description |
|---------------------------|---------|---------------|---|---------|--|
| DMA Channel Thread | 0 | DMAWFE | - | X | On event, execution continues, irrespective of the INS bit |
| | | DMASEV | - | X | Signals the appropriate event, irrespective of the INS bit |
| | | DMAWFP | X | - | On peripheral request, execution continues, irrespective of the PNS bit |
| | | DMALP, DMASTP | X | - | Sends a message to the PL peripheral to communicate that the last AXI transaction of the DMA transfer is complete, irrespective of the PNS bit |
| | | DMAFLUSH | X | - | Clears the state of the peripheral and sends a message to the peripheral to resend its level status, irrespective of the PNS bit |
| | 1 | DMAWFE | - | 0 | Abort |
| | | | - | 1 | On event, execution continues |
| | | DMASEV | - | 0 | Abort |
| | | | - | 1 | It signals the appropriate event |
| | | DMAWFP | 0 | - | Abort |
| | | | 1 | - | On peripheral request, execution continues |
| | | DMALP, DMASTP | 0 | - | Abort |
| | | | 1 | - | Sends a message to the peripheral to communicate that the last AXI transaction of the DMA transfer is complete |
| | | DMAFLUSHP | 0 | - | Abort |
| 1 | - | | It only clears the state of the peripheral and sends a message to the peripheral to resend its level status | | |

9.2.13 IP Configuration Options

The Xilinx implementation of the DMAC uses the IP configuration options shown in [Table 9-9](#).

Table 9-9: DMAC IP Configuration Options

| IP Configuration Option | Value |
|-----------------------------|-----------------------------|
| Data width (bits) | 64 |
| Number of channels | 8 |
| Number of interrupts | 16 (8 interrupts, 8 events) |
| Number of peripherals | 4 (to PL) |
| Number of cache lines | 8 |
| Cache line width (words) | 4 |
| Buffer depth (MIFIFO depth) | 1 |
| Read queue depth | 16 |

Table 9-9: DMAC IP Configuration Options (Cont'd)

| IP Configuration Option | Value |
|---------------------------------|------------------|
| Write queue depth | 16 |
| Read issuing capability | 8 |
| Write issuing capability | 8 |
| Peripheral request capabilities | All capabilities |
| Secure APB base address | 0xF800_3000 |
| Non-secure APB base address | 0xF800_4000 |

9.3 Programming Guide for DMA Controller

9.3.1 Startup

Example: Start-up Controller

1. **Configure Clocks.** Refer to section [9.6.1 Clocks](#)
2. **Configure Security State.** Refer to section [9.6.3 Reset Configuration of Controller](#)
3. **Reset the Controller.** Refer to section [9.6.2 Resets](#)
4. **Create Interrupt Service Routine.** Refer to section [9.3.3 Interrupt Service Routine](#)
5. **Execute DMA Transfers.** Refer to section [9.3.2 Execute a DMA Transfer](#)

9.3.2 Execute a DMA Transfer

1. **Write Microcode into Memory for DMA Transfer.** Refer to section [9.4 Programming Guide for DMA Engine](#)
 - a. Create a program for the DMA channel.
 - b. Store the program in a region of system memory.
2. **Start the DMA Channel Thread.** Refer to section [9.2.3 DMA Manager](#)

9.3.3 Interrupt Service Routine

There are two types of interrupt signals from the DMA controller to the PS interrupt controller:

- Eight DMAC IRQs [75:72] and [49:46]
- One DMAC ABOART IRQ [45]

An interrupt service routine (ISR) can be use for each type of interrupt. The two ISRs are described below. For more information on interrupts, refer to section [9.2.10 Events and Interrupts](#).

Example: IRQ Interrupt Service Routine

The following steps need to be performed in this routine. This routine can support all 8 DMAC IRQs.

1. **Check which event has caused the interrupt.** Read `dmac.INT_EVENT_RIS`.
2. **Clear the corresponding event.** Write to the `dmac.INTCLR` register.
3. **Inform the application that the DMA transfer has finished.** Call the user callback function if registered during DMA transfer setup.

Example: IRQ_ABORT Interrupt Service Routine

The following steps need to be performed in this routine.

1. **Determine if a Manager fault occurred.** Read `dmac.FSRD`. If the value of `fs_mgr` field is set, read `dmac.FTRD` to know about the fault type.
2. **Determine if a Channel fault occurred.** Read `dmac.FSRC`. If the value of `fault_status` field for a channel is set, read `dmac.FTRx` of the corresponding channel to know about the fault type.
3. **Execute DMAKILL instruction.** Do this for the DMA Manager or the DMA Channel Thread:
 - a. For the DMA Manager write the `dmac.DBGINST0` register (refer to [Appendix B, Register Details](#)) and enter the:
 - Instruction byte 0 encoding for DMAKILL.
 - `debug_thread` bit to 0. This selects the DMA manager.
 - b. For the DMA Channel Thread write the `dmac.DBGINST0` register and enter the:
 - Instruction byte 0 encoding for DMAKILL.
 - `channel_num` bit set to the channel number to kill.
 - `debug_thread` bit to 1. This selects the DMA channel thread.
 - c. Wait until the `dbgstatus` field in `dmac.DBGSTATUS` is busy.
 - d. Write 0x0 to the `dmac.DBGCMD` register to execute the instruction that the `DBGINSTx` registers contain.

9.3.4 Register Overview

[Table 9-10](#) provides an overview of the DMA Controller registers.

Table 9-10: DMAC Register Overview

| Function | Register Name | Overview |
|-----------------------|--|--|
| DMAC Control | <code>dmac.XDMAPS_DS</code> <code>dmac.XDMAPS_DPC</code> | Provides the security state and the program counter. |
| Interrupts and Events | <code>dmac.INT_EVENT_RIS</code> <code>dmac.INTCLR</code> <code>dmac.INTEN</code> <code>dmac.INTMIS</code> | Enables/disables the interrupt detection, mask interrupt sent to the interrupt controller, and reads raw interrupt status. |

Table 9-10: DMAC Register Overview (Cont'd)

| Function | Register Name | Overview |
|----------------------------------|--|--|
| Fault Status and Type | dmac.FSRD dmac.FSRC dmac.FTRD dmac.FTR{7:0} | Provides the fault status and type for the manager and the channels. |
| Channel Thread Status | dmac.CPC{7:0} dmac.CSR{7:0} dmac.SAR{7:0} dmac.DAR{7:0} dmac.CCR{7:0} dmac.LC0_{7:0} dmac.LC1_{7:0} | These registers provide the status of the DMA channel threads. |
| Debug | dmac.DBGSTATUS dmac.DBGCMD dmac.DBGINST{1,0} | These registers enable the user to send instructions to a channel thread. |
| IP Configuration | dmac.XDMAPS_CR{4:0} dmac.XDMAPS_CRDN | These registers enable system firmware to discover the hardwired configuration of the DMAC |
| Watchdog | dmac.WD | Controls how the DMAC responds when it detects a lock-up condition. |
| System-level | slcr.DMAC_RST_CTRL slcr.TZ_DMAC_NS slcr.TZ_DMA_IRQ_NS slcr.TZ_DMAC_PERIPH_NS slcr.DMAC_RAM slcr.APER_CLK_CTRL | Control reset, clock, and security state. |

9.4 Programming Guide for DMA Engine

The programming guide for the DMA Engine includes these section:

- [9.4.1 Write Microcode to Program CCRx for AXI Transactions](#)
- [9.4.2 Memory-to-Memory Transfers](#)
- [9.4.3 PL Peripheral DMA Transfer Length Management](#)
- [9.4.4 Restart Channel using an Event](#)
- [9.4.5 Interrupting a Processor](#)
- [9.4.6 Instruction Set Reference](#)

Note: Table 9-14 and Table 9-15, page 286 summarize the DMAC instructions and commands.

Note: Refer to the *Arm Application Note 239: Example programs for the CoreLink DMA Controller DMA-330* for more programming examples.

9.4.1 Write Microcode to Program CCRx for AXI Transactions

The channel microcode is used to set the `dmac.CCRx` registers to define the attributes of the AXI transactions. This is done using the `DMAMOV CCR` instruction.

The user should program the microcode to write to the `dmac.CCR{7:0}` register before it initiates a DMA transfer. Here are the AXI attributes that the microcode writes:

1. Program the `src_inc` and `dst_inc` bit fields based on the type of burst (incrementing or fixed address). This affects the `ARBURST[0]` and `AWBURST[0]` AXI signals.
2. Program the `src_burst_size` and `dst_burst_size` bit fields (number bytes per data beat on AXI). This affects the `ARSIZE[2:0]` and `AWSIZE[2:0]` AXI signals.
3. Program the `src_burst_len` and `dst_burst_len` bit fields (number of data beats per AXI burst transaction). This affects the `ARLEN[3:0]` and `AWLEN[3:0]` AXI signals.
4. Program the `src_cache_ctrl` and `dst_cache_ctrl` bit fields (caching strategy). This affects the `ARCACHE [2:0]` and `AWCACHE[2:0]` AXI signals.
5. Program the `src_prot_ctrl` and `dst_prot_ctrl` bit fields (security state of the manager thread.) If the manager thread is secure, `ARPROT[1]` should be set = 0 and if non-secure then it should be set = 1. `ARPROT[0]` and `ARPROT[2]` values should be set = 0. For example:
 - Set `src_prot_ctrl = 0'b000` if DMA Manager is secure,
 - Set `scr_prot_ctrl = 0'b010` if DMA Manager is non-secure
6. Program `endian_swap_size = 0` (no swapping).

9.4.2 Memory-to-Memory Transfers

This section shows examples of microcode that the DMAC executes to perform aligned, unaligned, and fixed data transfers. Refer to [Table 9-11](#) for aligned transfer, [Table 9-12](#) for unaligned transfer, and [Table 9-13](#) for Fixed transfer. MFIFO utilization is also described.

Note: If cached memory is used for the DMA transfers, the programmer should ensure that the cache coherency be maintained using appropriate cache operations. The cache entries corresponding to the memory address range should be cleaned and invalidated before programming DMA channel.

Table 9-11: DMAC Aligned Memory-to-Memory Transfers

| Description | Code | MFIFO Usage |
|--|---|---|
| <p>Simple Aligned Program In this program the source address and destination address are aligned with the AXI data bus width.</p> | <pre>DMAMOV CCR, SB4 SS64 DB4 DS64 DMAMOV SAR, 0x1000 DMAMOV DAR, 0x4000 DMALP 16 DMALD DMAST DMALPEND DMAEND</pre> | <p>Each DMALD requires four entries and each DMAST removes four entries. This example has a static requirement of zero MFIFO entries and a dynamic requirement of four MFIFO entries.</p> |
| <p>Aligned asymmetric program with multiple loads The following program performs four loads for each store and the source address and destination address are aligned with the AXI data bus width.</p> | <pre>DMAMOV CCR, SB1 SS64 DB4 DS64 DMAMOV SAR, 0x1000 DMAMOV DAR, 0x4000 DMALP 16 DMALD DMALD DMALD DMALD DMAST DMALPEND</pre> | <p>Each DMALD requires one entry and each DMAST removes four entries. This example has a static requirement of zero MFIFO entries and a dynamic requirement of four MFIFO entries.</p> |
| <p>Aligned asymmetric program with multiple stores The following program performs four stores for each load and the source address and destination address are aligned with the AXI data bus width.</p> | <pre>DMAMOV CCR, SB4 SS64 DB1 DS64 DMAMOV SAR, 0x1000 DMAMOV DAR, 0x4000 DMALP 16 DMALD DMAST DMAST DMAST DMAST DMALPEND DMAEND</pre> | <p>Each DMALD requires four entries and each DMAST removes one entry. This example has a static requirement of zero MFIFO entries and a dynamic requirement of four MFIFO entries.</p> |

Table 9-12: DMAC Unaligned Transfers

| Description | Code | MFIFO Usage |
|---|---|---|
| <p>Aligned source address to unaligned destination address</p> <p>In this program, the source address is aligned with the AXI data bus width but the destination address is unaligned. The destination address is not aligned to the destination burst size so the first DMAST instruction removes less data than the first DMALD instruction reads. Therefore, a final DMAST of a single word is required to clear the data from the MFIFO.</p> | <pre>DMAMOV CCR, SB4 SS64 DB4 DS64 DMAMOV SAR, 0x1000 DMAMOV DAR, 0x4004 DMALP 16 DMALD DMAST DMALPEND DMAMOV CCR, SB4 SS64 DB1 DS32 DMAST DMAEND</pre> | <p>The first DMALD instruction loads four double words but because the destination address is unaligned, the DMAC shifts them by four bytes, and therefore it only removes three entries on the first loop, leaving one static MFIFO entry. Each DMAST requires only four entries of data and therefore the extra entry remains in use for the duration of the program until it is emptied by the last DMAST. This example has a static requirement of one MFIFO entry and a dynamic requirement of four MFIFO entries.</p> |
| <p>Unaligned source address to aligned destination address</p> <p>In this program the source address is unaligned with the AXI data bus width but the destination address is aligned. The source address is not aligned to the source burst size so the first DMALD instruction reads in less data than the DMAST requires. Therefore, an extra DMALD is required to satisfy the first DMAST.</p> | <pre>DMAMOV CCR, SB4 SS64 DB4 DS64 DMAMOV SAR, 0x1004 DMAMOV DAR, 0x4000 DMALD DMALP 15 DMALD DMAST DMALPEND DMAMOV CCR, SB1 SS32 DB4 DS64 DMALD DMAST DMAEND</pre> | <p>The first DMALD instruction does not load sufficient data to enable the DMAC to execute a DMAST and therefore the program includes an additional DMALD, prior to the start of the loop. After the first DMALD, the subsequent DMALDs align with the source burst size. This optimizes the performance but it requires a larger number of MFIFO entries. This example has a static requirement of four MFIFO entries and a dynamic requirement of four MFIFO entries.</p> |

Table 9-12: DMAC Unaligned Transfers (Cont'd)

| Description | Code | MFIFO Usage |
|--|--|---|
| <p>Unaligned source address to aligned destination address, with excess initial load</p> <p>This program is an alternative to that described in unaligned source address to aligned destination address. The program uses a different sequence of source bursts which might be less efficient but requires fewer MFIFO entries.</p> | <pre>DMAMOV CCR, SB5 SS64 DB4 DS64 DMAMOV SAR, 0x1004 DMAMOV DAR, 0x4000 DMALD DMAST DMAMOV CCR, SB4 SS64 DB4 DS64 DMALP 14 DMALD DMAST DMALPEND DMAMOV CCR, SB3 SS64 DB4 DS64 DMALD DMAMOV CCR, SB1 SS32 DB4 DS64 DMALD DMAST DMAEND</pre> | <p>The first DMALD instruction loads five beats of data to enable the DMAC to execute the first DMAST. After the first DMALD, the subsequent DMALDs are not aligned to the source burst size, for example the second DMALD reads from address 0x1028. After the loop, the final two DMALDs read the data required to satisfy the final DMAST. This example has a static requirement of one MFIFO entry and a dynamic requirement of four MFIFO entries.</p> |
| <p>Aligned burst size, unaligned MFIFO</p> <p>In this program the destination address, which is narrower than the MFIFO width, aligns with the burst size but does not align with the MFIFO width.</p> | <pre>DMAMOV CCR, SB4 SS32 DB4 DS32 DMAMOV SAR, 0x1000 DMAMOV DAR, 0x4004 DMALP 16 DMALD DMAST DMALPEND DMAEND</pre> | <p>If the DMAC configuration has a 32-bit AXI data bus width then this program requires four MFIFO entries. However, in this example the DMAC has a 64-bit AXI data bus width and, because the destination address is not 64-bit aligned, it requires three rather than the expected two MFIFO entries. This example has a static requirement of zero MFIFO entries and a dynamic requirement of three MFIFO entries.</p> |

Table 9-13: DMAC Fixed Transfers

| Description | Code | MFIFO Usage |
|---|---|---|
| <p>Fixed destination with aligned address</p> <p>In this program the source address and destination address are aligned with the AXI data bus width, and the destination address is fixed.</p> | <pre>DMAMOV CCR, SB2 SS64 DB4 DS32 DAF DMAMOV SAR, 0x1000 DMAMOV DAR, 0x4000 DMALP 16 DMALD DMAST DMALPEND DMAEND</pre> | <p>Each DMALD in the program loads two 64-bit data transfers into the MFIFO. Because the destination address is a 32-bit fixed address then the DMAC splits each 64-bit data item across two entries in the MFIFO. This example has a static requirement of zero MFIFO entries and a dynamic requirement of four MFIFO entries.</p> |

9.4.3 PL Peripheral DMA Transfer Length Management

Example: Length Managed by Peripheral

The following example shows a DMAC program that transfers 64 words from memory to peripheral 0 when the peripheral sends a burst request ($\text{DMA}\{3:0\}_DRTYPE[1:0] = 01$). When the peripheral sends a single request ($\text{DMA}\{3:0\}_DRTYPE[1:0] = 00$) then the DMAC program transfers one word from memory to peripheral 0.

To transfer the 64 words, the program instructs the DMAC to perform 16 AXI bus transactions. Each transaction consists of a 4-beat burst ($SB=4, DB=4$), each beat of which moves a word of data ($SS=32, DS=32$).

In this example, the program shows use of the following instructions:

- DMAWFP instruction. The DMAC waits for either a burst or single request from the peripheral.
- DMASTPB and DMASTPS instructions. The DMAC informs the peripheral when a transfer is complete.

```
# Set up for burst transfers (4-beat burst, so SB4 and DB4),
# (word data width, so SS32 and DS32)
DMAMOV CCR SB4 SS32 DB4 DS32
DMAMOV SAR ...
DMAMOV DAR ...

# Initialize peripheral '0'
DMAFLUSHP P0

# Perform peripheral transfers
# Outer loop - DMAC responds to peripheral requests until peripheral
# sets drlast_0 = 1
DMALPFE

# Wait for request, DMAC sets request_type0 flag depending on the
# request type it receives
DMAWFP 0, periph

# Set up loop for burst request: first 15 of 16 sets of transactions
# Note: B suffix - conditionally executed only if request_type0
# flag = Burst
DMALP 15
    DMALDB
    DMASTB

# Only loopback if servicing a burst, otherwise treat as a NOP
DMALPENDB

# Perform final transaction (16 of 16). Send the peripheral
# acknowledgement of burst request completion
DMALDB
DMASTPB P0

# Perform transaction if the peripheral signals a single request
# Note: S suffix - conditionally executed only if request_type0
# flag = Single
```

```

DMALDS
DMASTPS P0

# Exit loop if DMAC receives the last request, that is, drlast_0 = 1
DMALPEND

DMAEND

```

Example: Length Managed by DMAC

This example shows a DMAC program that can transfer 1,027 words when a peripheral signals 16 consecutive burst requests and 3 consecutive single requests.

```

# Set up for AXI burst transfer
# (4-beat burst, so SB4 and DB4), (word data width, so SS32 and DS32)
DMAMOV CCR SB4 SS32 DB4 DS32
DMAMOV SAR ...
DMAMOV DAR ...

# Initialize peripheral '0'
DMAFLUSHP P0

# Perform peripheral transfers
# Burst request loop to transfer 1024 words
DMALP 16

# Wait for the peripheral to signal a burst request.
# DMAC transfers 64 words for each burst request
DMAWFP 0, burst

# Set up loop for burst request: first 15 of 16 sets of transactions
DMALP 15
  DMALD
  DMAST
DMALPEND

# Perform final transaction (16 of 16).
# Send the peripheral acknowledgement of burst request completion
DMALD
DMASTPB 0

# Finish burst loop
DMALPEND

# Set up for AXI single transfer (word data width, so SS32 and DS32)
DMAMOV CCR SB1 SS32 DB1 DS32

# Single request loop to transfer 3 words
DMALP 3

# Wait for the peripheral to signal a single request. DMAC to transfer
# one word
DMAWFP 0, single

# Perform transaction for single request and send completion
# acknowledgement to the peripheral
DMALDS

```

```
DMASTPS P0

# Finish single loop
DMALPEND

# Flush the peripheral, in case the single transfers were in response
# to a burst request
DMAFLUSHP 0

DMAEND
```

9.4.4 Restart Channel using an Event

When the INTEN register is programmed to generate an event, the DMASEV and DMAWFE instructions can be used to restart one or more DMA channels. Refer to the Interrupt Enable register in [Appendix B, Register Details](#).

The following sections describe the DMAC behavior when:

- DMAC executes DMAWFE before DMASEV
- DMAC executes DMASEV before DMAWFE

DMAC Executes DMAWFE before DMASEV

To restart a single DMA channel:

1. The first DMA channel executes DMAWFE and then stalls while it waits for the event to occur.
2. The other DMA channel executes DMASEV using the same event number. This generates an event, and the first DMA channel restarts. The DMAC clears the event, one DMA{3:0}_ACLK cycle after it executes DMASEV.

Multiple channels can be programmed to wait for the same event. For example, if four DMA channels have all executed DMAWFE for event 12, then when another DMA channel executes DMASEV for event 12, the four DMA channels all restart at the same time. The DMAC clears the event one clock cycle after it executes DMASEV.

DMAC Executes DMASEV before DMAWFE

If the DMAC executes DMASEV before another channel executes DMAWFE, then the event remains pending until the DMAC executes DMAWFE. When the DMAC executes DMAWFE, it halts execution for one DMA{3:0}_ACLK cycle, clears the event, and then continues execution of the channel thread.

For example, if the DMAC executes DMASEV 6 and none of the other threads have executed DMAWFE 6, then the event remains pending. If the DMAC executes DMAWFE 6 instruction for channel 4 and then executes DMAWFE 6 instruction for channel 3, then:

1. The DMAC halts execution of the channel 4 thread for one DMA{3:0}_ACLK cycle.
2. The DMAC clears event 6.
3. The DMAC resumes execution of the channel 4 thread.

- The DMAC halts execution of the channel 3 thread and the thread stalls while it waits for the next occurrence of event 6.

9.4.5 Interrupting a Processor

The controller provides the seven active-High sensitive interrupts (IRQ ID #75:72 and 49:46) to the CPUs via the interrupt controller (GIC). When the INTEN register is programmed to generate an interrupt, after the DMAC executes DMASEV, the controller sets the corresponding interrupt to an active High state. The controller can also generate an Abort interrupt (IRQ ID #45) as described in section 9.2.11 *Aborts*. The DMAC interrupt enable and mask control registers are shown in [Appendix B, Register Details](#).

An external microprocessor can clear the interrupt by writing to the Interrupt Clear register.

Executing DMAWFE does not clear an interrupt.

If the DMASEV instruction is used to notify a microprocessor when the DMAC completes a DMALD or DMAST instruction, Arm recommends that a memory barrier instruction be inserted before the DMASEV. Otherwise the DMAC might signal an interrupt before the AXI transaction complete.

This is demonstrated in the following example:

```

DMALD
DMAST

# Issue a write memory barrier
# Wait for the AXI write transfer to complete before the DMAC can
# send an interrupt
DMAWMB

# The DMAC sends the interrupt
DMASEV
    
```

9.4.6 Instruction Set Reference

[Table 9-14](#) and [Table 9-15](#) summarize the DMAC instructions and commands.

Refer to *Arm PrimeCell DMA Controller (PL330) Technical Reference Manual: AXI Characteristics for a DMA Transfer and AXI Master* for more information about the DMA Engine instructions.

Table 9-14: DMA Engine Instruction Summary

| Instruction | Mnemonic | Thread Usage: M = DMA Manager C = DMA Channel | |
|-----------------------------|-----------|---|---|
| Add Halfword | DMAADDH | - | C |
| Add Negative Halfword | DMAADNH | - | C |
| End | DMAEND | - | C |
| Flush and Notify Peripheral | DMAFLUSHP | - | C |
| Go | DMAGO | M | - |

Table 9-14: DMA Engine Instruction Summary (Cont'd)

| Instruction | Mnemonic | Thread Usage: M = DMA Manager C = DMA Channel | |
|-----------------------------|----------|---|---|
| | | | |
| Kill | DMAKILL | M | C |
| Load | DMALD | - | C |
| Load and Notify Peripheral | DMALDP | - | C |
| Loop | DMALP | - | C |
| Loop End | DMALPEND | - | C |
| Loop Forever | DMALPFE | - | C |
| Move | DMAMOV | - | C |
| No operation | DMANOP | M | C |
| Read memory Barrier | DMARMB | - | C |
| Send Event | DMASEV | M | C |
| Store | DMAST | - | C |
| Store and Notify Peripheral | DMASTP | - | C |
| Store Zero | DMASTZ | - | C |
| Wait For Event | DMAWFE | - | C |
| Wait For Peripheral | DMAWFP | - | C |
| Write memory Barrier | DMAWMB | - | C |

Table 9-15: DMA Engine Additional Commands Provided by the Assembler

| Directives | Mnemonic |
|--------------------------|------------|
| Place a 32-bit immediate | DCD |
| Place a 8-bit immediate | DCB |
| Loop | DMALP |
| Loop Forever | DMALPFE |
| Loop End | DMALPEND |
| Move CCR | DMAMOV CCR |

9.5 Programming Restrictions

Note: Refer to the *Arm PrimeCell DMA Controller (PL330) Technical Reference Manual: Programming Restrictions* for details about restrictions that apply when programming the DMAC.

There are four considerations:

- Fixed unaligned bursts
- Endian swap size restrictions
- Updating channel control registers during a DMA cycle (section, below)

- Full MFIFO causes DMAC watchdog to abort a DMA channel (section, below, titled Resource sharing between DMA channels)

The following sections describe these last two restrictions in detail.

9.5.1 Updating Channel Control Registers During a DMA Cycle

Prior to the DMAC executing a sequence of DMALD and DMAST instructions, the values software programs in to the CCRn register, SARn register, and DARn register control the data byte lane manipulation that the DMAC performs when it transfers the data from the source address to the destination address. Refer to the Channel Control registers, Source Address registers, and Destination Address registers in [Appendix B, Register Details](#).

These registers can be updated during a DMA cycle, but if certain register fields are changed, the DMAC might discard data. The following sections describe the register fields that might have a detrimental impact on a data transfer:

- Updates that affect the destination address
- Updates that affect the source address

Updates That Affect the Destination Address

If a DMAMOV instruction is used to update the DARn register or CCRn register part way through a DMA cycle, a discontinuity in the destination datastream might occur. A discontinuity occurs if any of the following is changed:

- dst_inc bit
- dst_burst_size field when dst_inc = 0, (fixed-address burst)
- DARn register so that it modifies the destination byte lane alignment. For example, when the bus width is 64 bits and bits [2:0] in the DARn register are changed.

When a discontinuity in the destination datastream occurs, the DMAC:

1. Halts execution of the DMA channel thread.
2. Completes all outstanding read and write operations for the channel (just as if the DMAC was executing DMARMB and DMAWMB instructions).
3. Discards any residual MFIFO data for the channel.
4. Resumes execution of the DMA channel thread.

Updates That Affect the Source Address

If a DMAMOV instruction is used to update the SARn register or CCRn register part way through a DMA cycle, a discontinuity in the source datastream might occur. A discontinuity occurs if any of the following is changed:

- src_inc bit
- src_burst_size field

- SARn register so that it modifies the source byte lane alignment. For example, when the bus width is 32 bits and bits [1:0] in the SARn register are changed.

When a discontinuity in the source datastream occurs, the DMAC:

1. Halts execution of the DMA channel thread.
2. Completes all outstanding read operations for the channel (just as if the DMAC was executing DMARMB instruction).
3. Resumes execution of the DMA channel thread. No data is discarded from the MFIFO.

Resource Sharing Between DMA Channels

DMA channel programs share the MFIFO data storage resource. A set of concurrently running DMA channel programs must not be started with a resource requirement that exceeds the configured size of the MFIFO. If this limit is exceeded, the DMAC might lock up and generate a watchdog abort.

The DMAC includes a mechanism called the load-lock to ensure that the shared MFIFO resource is used correctly. The load-lock is either owned by one channel, or it is free. The channel that owns the load-lock can execute DMALD instructions successfully. A channel that does not own the load-lock pauses at a DMALD instruction until it takes ownership of the load-lock.

A channel claims ownership of the load-lock when:

- It executes a DMALD or DMALDP instruction.
- No other channel currently owns the load-lock.

A channel releases ownership of the load-lock when any of the following controller actions occur:

- Executes a DMAST, DMASTP, or DMASTZ.
- Reaches a barrier, that is, it executes DMARMB or DMAWMB.
- Waits, that is, it executes DMAWFP or DMAWFE.
- Terminates normally, that is, it executes DMAEND.
- Aborts for any reason, including DMAKILL.

The MFIFO resource usage of a DMA channel program is measured in MFIFO entries, and rises and falls as the program proceeds. The MFIFO resource requirement of a DMA channel program is described using a static requirement and a dynamic requirement which are affected by the load-lock mechanism.

Arm defines the static requirement to be the maximum number of MFIFO entries that a channel is currently using before that channel does one of the following:

- Executes a WFP or WFE instruction.
- Claims ownership of the load-lock.

Arm defines the dynamic requirement to be the difference between the static requirement and the maximum number of MFIFO entries that a channel program uses at any time during its execution.

To calculate the total MFIFO requirement, add the largest dynamic requirement to the sum of all the static requirements.

To avoid DMAC lock-up, the total MFIFO requirement of the set of channel programs must be equal to or less than the maximum MFIFO depth. The DMAC maximum MFIFO depth is 1 words, 64 bits each.

9.6 System Functions

9.6.1 Clocks

The controller is clocked by the CPU_1x clock for the APB interface and by the CPU_2x clock on the AXI interface. Programming information for the CPU_1x and CPU_2x clocks is in [Chapter 25, Clocks](#).

Example: Enable Clocks

1. **Enable CPU_1x clock for APB.** This clock is likely already enabled for the interconnect.
2. **Enable CPU_2x clock for AXI.** This clock is likely already enabled for the interconnect by writing a 1 to `slcr.AER_CLK_CTRL[DMA_CPU_2XCLKACT]`.

Peripheral Request Interface Clock

The peripheral request interface is clocked by the DMA{3:0}_ACLK signals. All of the interface signals are listed in section [9.7.2 Peripheral Request Interface](#).

9.6.2 Resets

Controller Reset

The controller is reset using the `slcr.DMAC_RST_CLTR[DMAC_RST]` register bit. This bit is used in the controller startup example shown in section [Example: Start-up Controller](#).

PL Peripheral Reset

Use a general purpose I/O or other signal to the PL to reset PL peripherals.

9.6.3 Reset Configuration of Controller

[Table 9-16](#) shows the tie-off signals used to program security state of the DMAC. Depending on the state of the SLCR registers after reset, the DMA is configured in secure or non-secure mode. Refer to the *Arm PrimeCell DMA Controller (PL330) Technical Reference Manual: Security Usage* for more details.

Note: When set, each security state remains constant until the DMAC resets.

Note: After reset, the controller waits for software to begin executing, refer to section [9.2.3 DMA Manager](#).

Table 9-16: DMAC Initialization Signals

| Name | Type | Source | Description |
|---------------------|-------|-----------------------------------|---|
| boot_manager_ns | Input | SLCR register TZ_DMA_NS | Controls the security state of the DMA manager, when the DMAC exits from reset: 0: Assigns DMA manager to the secure state 1: Assigns DMA manager to the non-secure state |
| boot_irq_ns[15:0] | Input | SLCR register TZ_DMA_IRQ_NS | Controls the security state of an event-interrupt resource, when the DMAC exits from reset: <ul style="list-style-type: none"> boot_irq_ns[x] is Low: Assigns event<x> or irq[x] to the secure state boot_irq_ns[x] is High: Assigns event<x> or irq[x] to the non-secure state |
| boot_periph_ns[3:0] | Input | SLCR register TZ_DMA_PERIPH_NS | Controls the security state of a peripheral request interface, when the DMAC exits from reset: <ul style="list-style-type: none"> boot_periph_ns[x] is Low: Assigns peripheral request interface x to the secure state boot_periph_ns[x] is High: Assigns peripheral request interface x to the non-secure state |
| boot_addr[31:0] | Input | Hard-wired 32'h0 | Configures the address location that contains the first instruction that the DMAC executes, when the DMAC exits from reset. Note: The DMAC only uses this address when boot_from_pc is High. |
| boot_from_pc | Input | Hard-wired 1'b0 | Controls the location of where the DMAC executes its initial instruction, after the DMAC exits from reset: 0: DMAC waits for an instruction from either APB interface 1: DMA manager executes the instruction that is located at the address provided by boot_addr[31:0] |

9.7 I/O Interface

9.7.1 AXI Master Interface

The AXI bus transaction attributes for caching, burst type and size, protection, etc are programmed by microcode as described in section 9.4.1 [Write Microcode to Program CCRx for AXI Transactions](#).

9.7.2 Peripheral Request Interface

The peripheral request interfaces support the connection of DMA-capable peripherals to enable memory-to-peripheral and peripheral-to-memory DMA transfers to occur, without intervention from a microprocessor. These peripherals must be in the PL and attached to the M_AXI_GP interface. All peripheral request interface signals are synchronous to the respective clocks.

Table 9-17: DMAC PL Peripheral Request Interface Signals

| Type | I/O | Name | Description |
|-----------------|-----|----------------------|---|
| Clock | I | DMA{3:0}_ACLK | Clock for DMA request transfers |
| DMA Request | I | DMA{3:0}_DRVALID | Indicates when the peripheral provides valid control information: 0: No control information is available 1: DMA{3:0}_DRTYPE[1:0] and DMA{3:0}_DRLAST contain valid information for the DMAC |
| | I | DMA{3:0}_DRLAST | Indicates that the peripheral is sending the last AXI data transaction for the current DMA transfer: 0: Last data request is not in progress 1: Last data request is in progress Note: The DMAC only uses this signal when DMA{3:0}_DRTYPE[1:0] is b00 or b01. |
| | I | DMA{3:0}_DRTYPE[1:0] | Indicates the type of acknowledgement, or request, that the peripheral signals: 00: Single level request 01: Burst level request 10: Acknowledging a flush request that the DMAC requested 11: Reserved |
| | O | DMA{3:0}_DRREADY | Indicates if the DMAC can accept the information that the peripheral provides on DMA{3:0}_DRTYPE[1:0]: 0: DMAC not ready 1: DMAC ready |
| DMA Acknowledge | O | DMA{3:0}_DAVALID | Indicates when the DMAC provides valid control information: 0: No control information is available 1: DMA{3:0}_DATYPE[1:0] contains valid information for the peripheral |
| | I | DMA{3:0}_DAREADY | Indicates if the peripheral can accept the information that the DMAC provides on DMA{3:0}_DATYPE[1:0]: 0: Peripheral not ready 1: Peripheral ready |
| | I | DMA{3:0}_DATYPE[1:0] | Indicates the type of acknowledgement, or request, that the DMAC signals: 00: DMAC has completed the single AXI transaction 01: DMAC has completed the AXI burst transaction 10: DMAC requesting the peripheral to perform a flush request 11: Reserved |

DDR Memory Controller

10.1 Introduction

The DDR memory controller supports DDR2, DDR3, DDR3L, and LPDDR2 devices and consists of three major blocks: an AXI memory port interface (DDRI), a core controller with transaction scheduler (DDRC) and a controller with digital PHY (DDRP).

The DDRI block interfaces with four 64-bit synchronous AXI interfaces to serve multiple AXI masters simultaneously. Each AXI interface has its own dedicated transaction FIFO.

The DDRC contains two 32-entry content addressable memories (CAMs) to perform DDR data service scheduling to maximize DDR memory efficiency. It also contains fly-by channel for low latency channel to allow access to DDR memory without going through the CAM.

The PHY processes read/write requests from the controller and translates them into specific signals within the timing constraints of the target DDR memory. Signals from the controller are used by the PHY to produce internal signals that connect to the pins via the digital PHYs. The DDR pins connect directly to the DDR device(s) via the PCB signal traces.

The system accesses the DDR via DDRI via its four 64-bit AXI memory ports. One AXI port is dedicated to the L2-cache for the CPUs and ACP, two ports are dedicated to the AXI_HP interfaces, and the fourth port is shared by all the other masters on the AXI interconnect.

The DDR interface (DDRI) arbitrates the requests from the eight ports (four reads and four writes). The arbiter selects a request and passes it to the DDR controller and transaction scheduler (DDRC). The arbitration is based on a combination of how long the request has been waiting, the urgency of the request, and if the request is within the same page as the previous request.

The DDRC receives requests from the DDRI through a single interface. Both reads and writes flow through this interface. Read requests include a tag field that is returned with the data from the DDR. The DDR controller PHY (DDRP) drives the DDR transactions.

10.1.1 Features

DDR Controller System Interface (DDR1)

The DDR controller system interface has these features:

- Four identical 64-bit AXI ports support INCR and WRAP burst types
- Four 64-bit AXI interfaces with separate read/write ports and 32-bit addressing
- Write data byte enable support for each data beat
- Sophisticated arbitration schemes to prevent data starvation
- Low latency path using urgent bit to bypass arbitration logic
- Deep read and write command acceptance capability
- Out-of-order read data returned for requests with different master ID
- Nine-bit AXI ID signals on all ports
- Burst length support from 1 to 16 data beats
- Burst sizes of 1, 2, 4, 8 (bytes per beat)
- Does not support locked accesses from any AXI port
- Low latency read mechanism using HPR queue
- Special urgent signaling to each port
- TrustZone regions programmable on 64 MB boundaries
- Exclusive accesses for two different IDs per port (locked transactions are not supported, cannot do exclusive access across different ports, see [Exclusive AXI Accesses in Chapter 5](#))

DDR Controller PHY (DDRP)

The DDR controller PHY has these features:

- Compatible DDR I/Os
 - 1.2V LPDDR2
 - 1.8V DDR2
 - 1.5V DDR3 and 1.35V DDR3L
- Selectable 16-bit and 32-bit data bus widths
- Optional ECC in 16-bit data width configuration
- Self-refresh entry on software command and automatic exit on command arrival
- Autonomous DDR power down entry and exit based on programmable idle periods
- Data read strobe auto-calibration

DDR Controller Core and Transaction Scheduler (DDRC)

The DDR controller core and transaction scheduler has these features:

- Efficient transaction scheduling to optimize data bandwidth and latency
- Advanced re-ordering engine to maximize memory access efficiency for continuous reads and writes as well as random reads and writes
- Write - read address collision detection to avoid data corruption
- Obeys AXI ordering rules

10.1.2 Block Diagram

The block diagram for the DDR memory controller is shown in Figure 10-1. The DDR memory controller consists of an arbiter, a core with transaction scheduler, and the physical sequencing of the DDR memory signals.

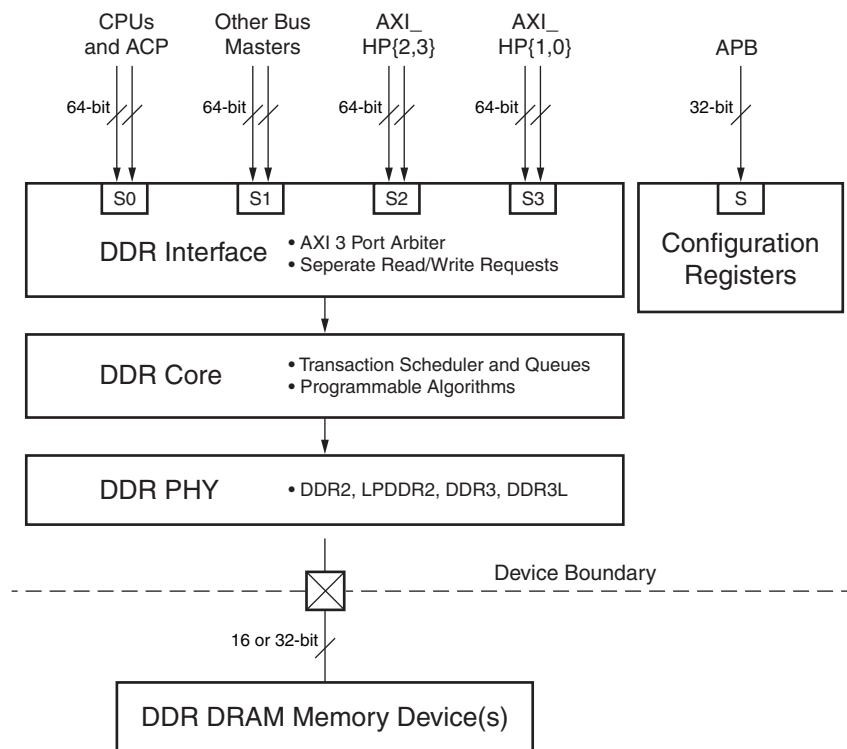

UG585_c10_01_120913

Figure 10-1: DDR Memory Controller Block Diagram

The controller core and transaction scheduler contains two 32-entry CAMs to perform DDR data service re-ordering to maximize DDR memory access efficiency. It also contains a fly-by channel for low latency access to DDR memory without going through the CAM.

The PHY processes read/write requests from the controller and translates them into specific signals within the timing constraints of the target DDR memory. Signals from the controller are used by the PHY to produce internal signals that connect to the pads of the PS using the PHY. The pads connect directly, via the PCB signal traces, to the external memory devices.

The arbiter arbitrates across the four AXI ports for access to the DDR core. The arbitration is priority based and also allows promotion of priorities via an *urgent* mechanism.

10.1.3 Notices

7z007s and 7z010 CLG225 Devices

All devices support the 32- and 16-bit data bus width options except the 7z007s single core and 7z010 dual core CLG225 devices. These CLG225 devices only support the 16-bit data bus width, not the 32-bit bus.

10.1.4 Interconnect

The four AXI_HP interfaces are multiplexed down, in pairs, and are connected to ports 2 and 3 as shown in Figure 10-2. These ports are commonly configured for high bandwidth traffic. The path from these four interfaces to the DDR include two ports on the DDR memory port arbiter. The interconnect switch arbitrates back-and-forth between each of the two ports. Read and write channels operate separately. The arbitration in the bridge can be affected by the QoS signals from each PL interface. A requestor with a higher QoS value is given preferential treatment by the interconnect bridge. Arbitration is priority based using QoS as priority. In the event of a tie, an LRG scheme is used to break the tie.

The L2-cache is connected to port 0 and is used to serve the CPUs and the ACP interface to the PL. This port is commonly configured for low-latency. The other masters on the AXI interconnect are connected to port 1.

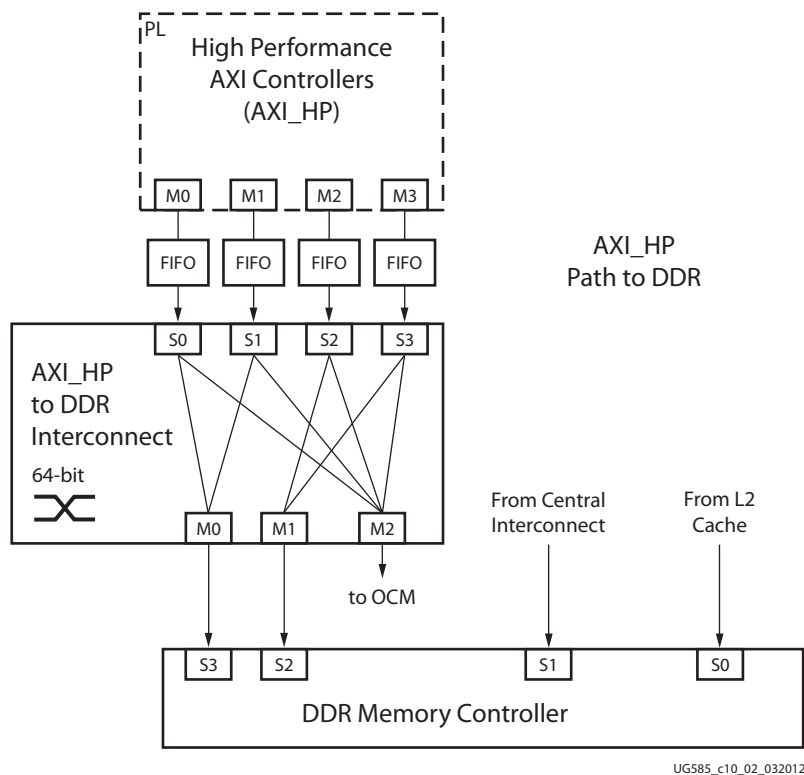

Figure 10-2: DDRC System Viewpoint

10.1.5 DDR Memory Types, Densities, and Data Widths

The DDR memory controller is able to connect to devices under the conditions identified in [Table 10-1](#).

Table 10-1: Connectivity Limitations

| Parameter | Value | Notes |
|------------------------------|-----------|--|
| Maximum Total Memory Density | 1 GB | 1 GB of address map is allocated to DRAM |
| Total Data Width (bits) | 16, 32 | ECC can only use a 32-bit configuration: 16 data bits, 10 check bits |
| Component Data Width (bits) | 8, 16, 32 | 4-bit devices are not supported |
| Maximum Ranks | 1 | |
| Maximum Row Address (bits) | 15 | |
| Maximum Bank Address (bits) | 3 | |

[Table 10-2](#) provides a collection of example memory configurations.

Table 10-2: Example Memory Configurations

| Technology | Component Configuration | Number of Components | Component Density | Total Width | Total Density |
|------------|-------------------------|----------------------|-------------------|-------------|---------------|
| DDR3/DDR3L | x16 | 2 | 4 Gb | 32 | 1 GB |
| DDR2 | x8 | 4 | 2 Gb | 32 | 1 GB |
| LPDDR2 | x32 | 1 | 2 Gb | 32 | 256 MB |
| LPDDR2 | x16 | 2 | 4 Gb | 32 | 1 GB |
| LPDDR2 | x16 | 1 | 2 Gb | 16 | 256 MB |

10.1.6 I/O Signals

The DDR signal pins are listed in [Table 10-3](#). The DDR I/O buffers are powered by the VCC_DDR power pins. The I/O state (including initial state) of the DDR signals is controlled via registers:

- slcr.DDRIOB_ADDR0
- slcr.DDRIOB_ADDR1
- slcr.DDRIOB_DATA0
- slcr.DDRIOB_DATA1
- slcr.DDRIOB_DIFF0
- slcr.DDRIOB_DIFF1
- slcr.DDRIOB_CLOCK

The output characteristics are controlled by the following registers and are reserved to specific values produced by Xilinx tools:

- slcr.DDRIOB_DRIVE_SLEW_ADDR

- slcr.DDRIOB_DRIVE_SLEW_DATA
- slcr.DDRIOB_DRIVE_SLEW_DIFF
- slcr.DDRIOB_DRIVE_SLEW_CLOCK

The input Vref settings are controlled by slcr.DDRIOB_DDR_CTRL. The DDR DCI settings are controlled by slcr.DDRIOB_DCI_CTRL.

Note: The 7z010 dual core and 7z007s single core CLG225 devices only support a 16-bit data bus width, not a 32-bit bus width.

Table 10-3: DDR I/O Signal Pin List

| Device Pin Name | I/O | Connections | | | Description |
|--|-----|-------------|--------|------------|---|
| | | DDR2 | LPDDR2 | DDR3/DDR3L | |
| PS_DDR_CKP PS_DDR_CKN | O | X | X | X | Differential clock outputs |
| PS_DDR_CKE | O | X | X | X | Clock enable |
| PS_DDR_CS_B | O | X | X | X | Chip select |
| PS_DDR_RAS_B | O | X | | X | RAS row address strobe |
| PS_DDR_CAS_B | O | X | | X | RAS column address strobe |
| PS_DDR_WE_B | O | X | | X | Write enable |
| PS_DDR_BA[2:0] | O | X | | X | Bank address |
| PS_DDR_A[14:0] | O | X | X | X | DDR3/DDR3L/DDR2: Row/Column Address LPDDR2: CA[9:0] = DDR_A[9:0] |
| PS_DDR_ODT | O | X | | X | Output dynamic termination signal |
| PS_DDR_DRST_B | O | | | X | Reset |
| PS_DDR_DQ[31:0] | IO | X | X | X | 32-bit Data bus: [31:0] 16-bit Data bus: [15:0] 16-bit Data with ECC |
| PS_DDR_DM[3:0] | O | X | X | X | Data byte masks |
| PS_DDR_DQS_P[3:0] PS_DDR_DQS_N[3:0] | IO | X | X | X | Differential data strobes |
| PS_DDR_VR{P,N} | ~ | X | X | X | DCI voltage reference. Used to calibrate input termination, and DDR I/O drive strength. Connect DDR_VRP to a resistor to GND. Connect DDR_VRN to a resistor to VCC_DDR. [Ref 1] |
| PS_DDR_VREF[1:0] | ~ | X | X | X | Voltage reference |

Notes:

1. PS_DDR_VR{P,N} signals should be bypassed from BSCAN.

10.2 AXI Memory Port Interface (DDRI)

10.2.1 Introduction

Each AXI master port has an associated slave port in the arbiter. The command FIFO located inside the port stores the address, length and ID contained in the command. The RAM in the write port stores the write data and byte enable. The RAM in the read port stores the read data coming back from the core.

Because the read data coming back from the core can come out of order, the RAM is used for data re-ordering. Each AXI command can make a request (write or read) for up to 16 data transfers (up to the AXI limit). A single command coming from the AXI can be split into multiple requests going to the arbiter logic and the controller.

The incoming command is first stored in the command FIFO. After a valid command is detected in the write or read port, the value of the length field is checked and the number of requests associated with this command is calculated. The logic then sends arbiter requests to the arbitration logic. The arbitration logic looks at the requests from all the ports and gives the grant to one port at a time.

When a write port receives the grant from the arbiter, it generates write address, and write data pointer and asserts the command valid. A read port on receiving grant generates read address, read command length and the read token and asserts the command valid. Requests from various ports are multiplexed using the grant signal.

When a write command is accepted by the DDR controller, it sends the write data pointer back to the arbiter. The write data from all ports is multiplexed using the port ID contained in the write data pointer.

When the read data comes back from the core, an associated ID is used to direct the data to the appropriate read port. According to AXI specifications, the read data with the same ID is required to be given back to the AXI read master in the same order in which read commands were received by the port.

10.2.2 Block Diagram

The block diagram of the DDRI is shown in Figure 10-3.

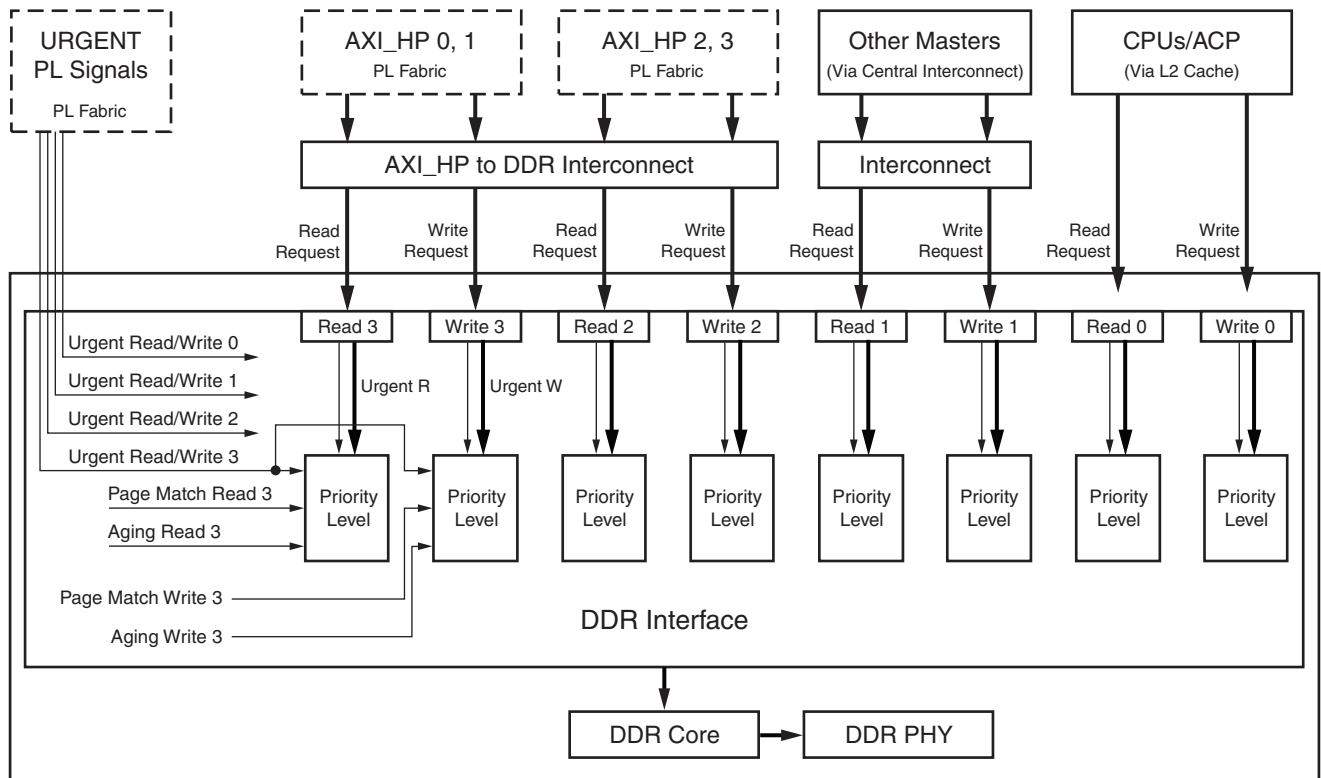

UG585_c10_03_012113

Figure 10-3: DDRI Block Diagram

10.2.3 AXI Feature Support and Limitations

This list shows supported and unsupported features for the AXI ports into the DDRI:

- Fixed burst type is not supported. Note that the behavior is unknown if this transfer type is received at one of the AXI ports.
- Byte, half-word and word sub-width commands are supported.
- EXCL accesses are only supported on a single DDR port, ie., there is no support for EXCL accesses across DDR ports.
- AWPROT/ARPROT[1] bit is used for trust zone support, AWPROT/ARPROT[0], and AWPROT/ARPROT[2] bits are ignored and do not have any effect.
- ARCACHE[3:0]/AWCACHE[3:0] (cache support) are ignored, and do not have any effect.
- Sparse AXI write transfers (random strobes asserted/de-asserted for any data beat) are supported.
- Unaligned transfers are supported.

10.2.4 TrustZone

The DDR memory can be configured in 64 MB sections. Each section can be configured to be either secure or non-secure. This configuration is provided via a system level control register.

- A 0 on a particular bit indicates a secure memory region for that particular memory segment.
- A 1 on a particular bit indicates a non-secure memory region for that particular memory segment.

In the case of a non-secure access to a secure region, a DECERR response is returned back to the master. For writes, the write data is masked out before being sent to the controller which results in no actual writes occurring in the DRAM. On reads, the read data is all zeros on a TZ violation. For more information on TrustZone see *Programming ARM TrustZone Architecture on the Xilinx Zynq-7000 SoC* (UG1019).

10.3 DDR Core and Transaction Scheduler (DDRC)

The DDRC is comprised of queues for pending read and write transactions and a scheduler that pops off the queues and sends the next transaction to the DDR PHY. Between the DDRI and the DDRC, there is arbitration logic to decide which transaction is sent to the DDRC next.

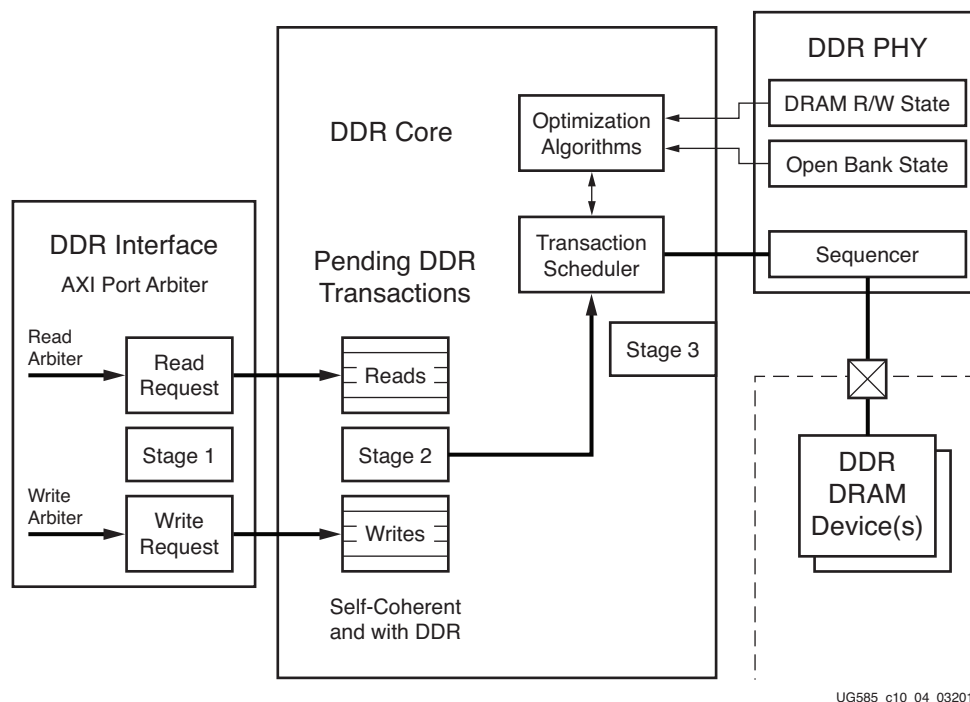

Figure 10-4: DDRC Block Diagram

10.3.1 Row/Bank/Column Address Mapping

The DDRC is responsible for mapping byte-addressable physical addresses used by the PS and PL AXI masters to DDR row, bank and column addresses. This address mapping has a limited configurability to allow user optimization. Optimizing the mapping to specific data access patterns can allow increased DDR utilization by reducing page and row change overhead.

Note: Many combinations of address remapping are not available, notably a complete bank-row-column mapping.

The address mapper associates linear request addresses to DRAM addresses by selecting the AXI bit that maps to each and every applicable DRAM address bit. The full available address space is only accessible to the user when no two DRAM address bits are determined by the same AXI address bit.

Each DRAM row, bank, and column address bit has an associated register vector to determine its associated AXI source in the DDRC `DRAM_addr_map_bank`, `DRAM_addr_map_row`, and `DRAM_addr_map_col` registers. The associated AXI address bit is determined by adding the internal base of a given register to the programmed value for that register, as described in the following equation:

$$[\text{internal base}] + [\text{register value}] = [\text{AXI address bit number}]$$

For example, from the description for `reg_ddrc_addrmap_col_b3`, it can be seen that this register determines the mapping for DRAM column bit 4 and its internal base is 6. When the full data bus is in use, DRAM column bit 4 is determined by the following:

$$[\text{internal base}] + [\text{register value}].$$

If `reg_ddrc_addrmap_col_b3` register is programmed to 2, then the AXI address bit is:

$$6 + 2 = 8.$$

In other words, the column address bit 4 sent to DRAM is mapped to AXI address bit `*_ADDR[8]`.

All the column bits left-shift one bit in half bus width mode (including ECC). In this case, `reg_ddrc_addrmap_col_b2` determines the mapping of DRAM column address bit 4. In the full bus width case, `reg_ddrc_addrmap_col_b3` determines DRAM column address 4.

10.4 DDRC Arbitration

The DDRC arbitration consists of three stages (see [Figure 10-5](#)):

- Stage 1 is AXI read/write port arbitration
- Stage 2 is winner of read and write compete
- Stage 3 is transaction scheduler

Each of these stages has their own arbitration steps that will be discussed in more detail.

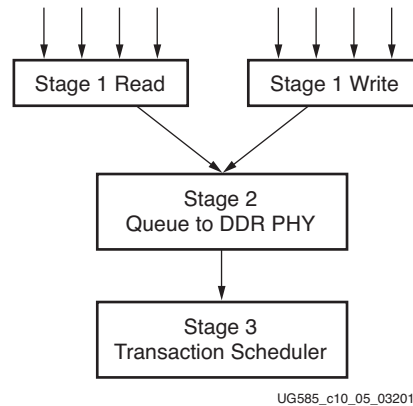

Figure 10-5: DDRC Arbitration

10.4.1 Priority, Aging Counter and Urgent Signals

DDR controller arbitration is based on round robin with aging. The round robin mechanism circularly scans all requesting devices and services all outstanding requests before servicing the same device again. The aging mechanism measures the time each request has been pending and assigns higher priority to requests with longer wait times.

Each of the DDRC read and write ports is assigned a 10-bit priority value (see registers `axi_priority_wr_port0-3` and `axi_priority_rd_port0-3`). This value is used as an initial value for an aging counter that counts down. Thus at any instant, a lower aging counter value takes priority over a higher one.

In addition, each of the DDRC read and write ports has an *urgent* input signal. This signal acts as a reset to the aging counter. When urgent is asserted, the aging counter for that port is reset, instantly making this port's priority the highest. The source of the urgent bit is selectable via an SLCR host-programmable register (`DDR_URGENT_SEL`) to be one of the following:

- The most-significant bit of the 4-bit QoS signal in the AXI interface for a port (except for memory port 0 used by the CPUs and APU)
- A programmable SLCR register value (`DDR_URGENT`)
- One of the PL signal `DDRARB[3:0]` bits

While the priority value is static in nature, the urgent bit and QoS signal can be manipulated dynamically.

10.4.2 Page-Match

To improve DDR utilization, the address of each new request is compared with the address of the previous request. The DDRC has a preference for taking new requests that are to the same page as the previous request. The memory port compares the addresses to determine if there is a page match. A port that has been selected by the arbiter continues to get preference (priority 0) as long as there continues to be page hits. They will compete against other ports with a priority of 0.

The page size is defined by PAGE_MASK (32 bit register that all bits are the mask) and is always address aligned. For proper operation, the software must program the page size in the PAGE_MASK to match the size of the DDR memory. Setting this register to 0 disables the page-match step of the arbitration.

10.4.3 Aging Counter

When a request is pending and not serviced, a decrementing aging counter is enabled. The starting value of this counter is loaded from the 10-bit value in the priority register (`axi_priority_<rd/wr>_port<n>`, there are 8 registers, one for each ports). The counter reloads when the request is serviced. The value of this counter is used to help indicate the priority of an AXI memory port. The lower the value of this counter, the higher the priority. When the priority reaches 0, the request has the highest priority.

For arbitration purposes, only the upper-most 5 bits are used to differentiate priority among ports. This keeps the arbitration mechanism to a manageable size and latency, while still comprehending an approximation of the age-based priority of each port.



TIP: *In normal usage mode, enabling aging is the suggested option. Disabling aging can result in excessive latencies/starvation of low priority ports.*

10.4.4 Stage 1 – AXI Port Arbitration

The eight ports (four read and four write) compete to get the DDRC to accept their request. The arbiter grants a request based on many factors. Read and write requests are treated the same, meaning they go through the same arbitration. Each port maintains a priority level that steadily moves from a preset state to the highest state or 0. This mechanism is important to maintain a minimum bandwidth on a port. Each port also has different ways to signal an urgent situation, either on a per-transaction basis (QoS) or for multiple transactions. The per-transaction urgency can be good for low-latency masters.

The priority as shown in [Figure 10-6](#) has the following logic. If there is a port with Priority 0 or 0 in its aging counter (the highest priority), then it wins. If there is no port with 0 priority, the arbitration checks if the port being serviced has a page match. If there is no page match, the lowest value in the aging counter wins. If there is a tie for the lowest value in the aging counter, round robin is used to resolve any ties.

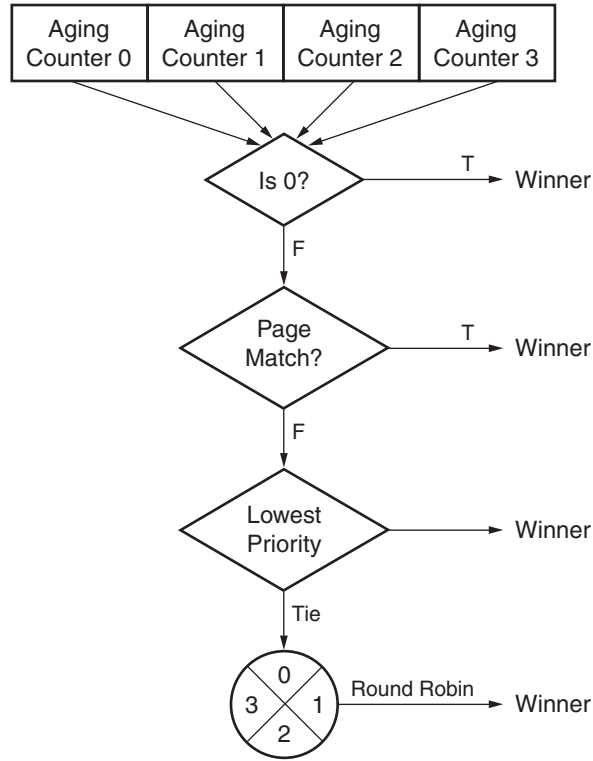

UG585_c10_06_050212

Figure 10-6: Stage 1 – AXI Port Arbitration

10.4.5 Stage 2 – Read Versus Write

The reads and the writes each have a queue in the DDR Core. The entries in these queues then vie for the next level of arbitration, shown in [Figure 10-7](#).

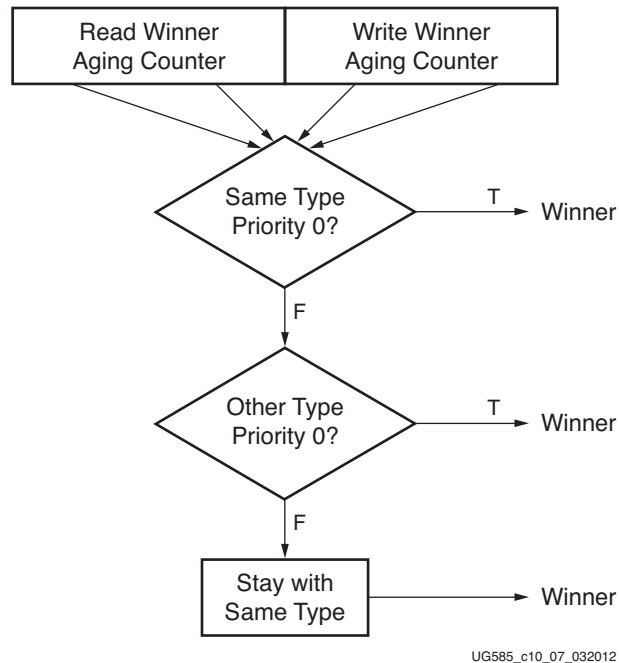
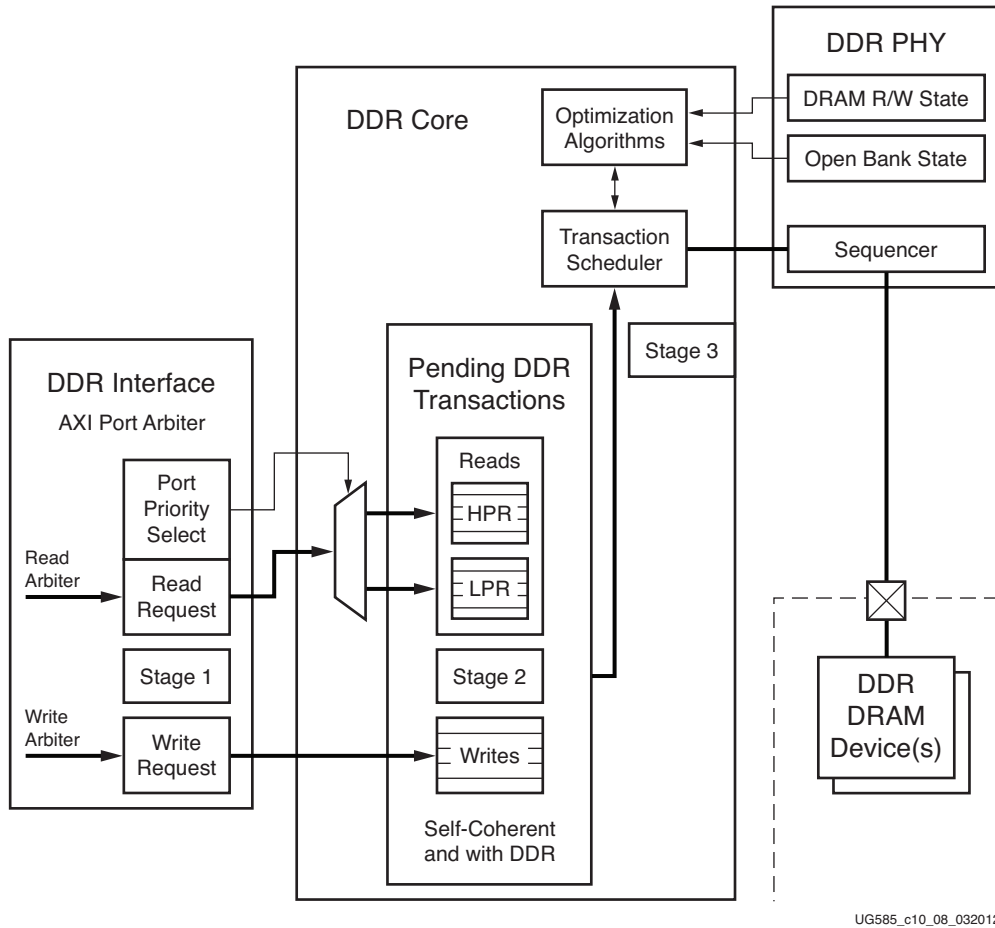

Figure 10-7: Stage 2 – Read Versus Write

This stage of arbitration starts with the aging counter as shown in [Figure 10-7](#). If there is a same type of transaction with a priority 0, it wins. For example if a read won the last round of arbitration and there is a read with priority 0, it wins. If there is not a same type of transaction with priority 0, and another type of transaction with a priority 0 is present, it wins. If there is no Priority 0 in the queue then it stays with the same type of transaction. An appropriate credit availability check is done before selecting any request in all the above cases.

10.4.6 High Priority Read Ports

Before going into Stage 3 of the arbitration, a feature of the DDRC, the high priority read, needs to be described. The HPR, or high priority read feature, allows splitting the read data queue (32 words) within the DDRC into two separate queues for low and high priority. Each of the four read ports can be assigned a low or high priority. By default this feature is disabled. When used, a high priority read device is not slowed down by the (potentially slower) read data rate of a low-priority device. In a typical use case, HPR is enabled on port 0 (CPU), thus reducing the CPU average read latency. The split of the read data queue does not have to be two equal parts. Thus giving the CPU a small queue to bypass the larger queue to service reads that need a lower latencies. [Figure 10-8](#) shows where the read queue is split.



UG585_c10_08_032012

Figure 10-8: Read Queue

This can be changed by setting the `reg_arb_set_hpr_rd_port<n>` bit to `1'b1` for AXI ports (this is in the `axi_priority_<rd/wr>_port<n>` register). The DDRC is configured by default to serve only LPR. The read CAM can service only LPR by default. The total CAM depth is 32 for Read. (However, one slot is always allocated for ECC purposes.) The `reg_ddrc_lpr_num_entries` register field in the DDRC `ctrl_reg1` register specifies the number of entries reserved for LPR. Taking 31 and subtracting the `reg_ddrc_lpr_num_entries` gives the number of entries reserved for HPR.

It is necessary to change the `REG_DDRC_LPR_NUM_ENTRIES` field if a port is configured as an HPR port to avoid deadlock in the credit mechanism

10.4.7 Stage 3 – Transaction State

The transaction state is the last stage of arbitration before the transaction goes to the DDR PHY and the DDR device. The transaction state can be read or write. To change the transaction state there must be no more transactions of that type or there can be a critical transaction of the other type. Figure 10-9 shows the simple state machine for this.

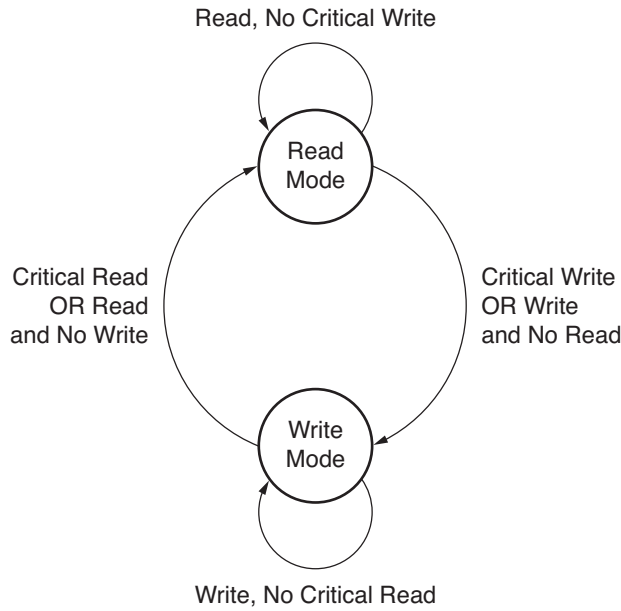

UG585_c10_09_032012

Figure 10-9: Stage 3 – Transaction State

The transaction state stays the same until the other type of transaction is critical or there is no more of that type of transaction. The state machine defaults to the read state. Table 10-4 shows how a transaction in the queue can go from a normal state to critical.

Table 10-4: Transaction Store State Transitions

| | | |
|-------------------|-------------------|---|
| Normal | Critical | A transaction has been pending for this transaction store and has not been serviced for a count of *_max_starve_x32 pulses of the 32-cycle timer. |
| Critical | Hard Non-Critical | *_xact_run_length number of transactions has been serviced from this transaction store. |
| Hard Non-Critical | Normal | *_min_non_critical number of cycles has passed in this state. |

Notes:

* Can be WR, LPR or HPR. Example is wr_max_starve_x32 which is a field of the WR_Reg.

Taking the low priority read transaction store as an example, it is expected that the transaction store generally functions independently based on the following signals:

- lpr_max_starve_x32
- lpr_xact_run_length
- lpr_min_non_critical

The reg_arb_go2critical_en field in the DDRC ctrl_reg2 register enables the arbiter to drive co_gs_go2critical_* signals to the DDRC. There are sideband signals on AXI (awurgent and arurgent) that drive the co_gs_go2critical_* signals. If any port asserts their urgent sideband signal, and if this feature is enabled, the arbiter asserts the corresponding co_gs_go2critical_* signal to the controller.

Inside the controller, assertion of this signal causes the state machine to switch from one state to another. For example, if the DDRC is currently servicing reads and `co_gs_go2critical_wr` goes High, the controller ignores the normal state switching methods (starvation counter etc), and jumps to servicing writes. There is a register in the controller to control how long to keep servicing the current command type before switching to the other (`reg_ddrc_go2critical_hysteresis` field in the DDRC `ctrl_reg2`).

In summary, this `go2critical` feature is used in the controller and ensures fast switching between reads and writes for transactions with super high priority.

Note:

1. The normal programming condition is expected to be `reg_ddrc_prefer_Write=0`. (this is a bit field in the `DRAM_param_reg4` register) This means that the read requests are always serviced immediately when received by an idle controller. Also, it is often desirable to set the `reg_ddrc_rdwr_idle_gap` (this field is in the `ddrc_ctrl` register) to a very low number (such as 0, 1, or 2) to ensure that writes do not go un-serviced in an otherwise-idle controller for any length of time, wasting bandwidth. (The trade-off here is that by servicing writes more quickly, the likelihood increases that reads issued to the controller immediately following writes incurs additional latency to allow writes to be serviced and turn the bus around.)
2. Because the ordering is guaranteed on all requests issued to the controller, write latency must not be a concern to system design. (In the event that write data is required by a subsequent read, the controller automatically forces the write data out to DRAM before servicing the read.)

10.4.8 Read Priority Management

Normally in a read mode, high priority read requests are preferred for service over low priority read requests. However, if the low priority read transaction store is critical and the high priority read transaction store is not, then low priority read requests are preferred over high priority read requests. This prevents starvation of low priority reads.

10.4.9 Write Combine

The write combine feature allow multiple writes to the same address to be combined into a single write to DRAM. When a new write collides with a queued write in the CAM:

- If write combine is enabled, the DDRC overwrites the data for the old write with that from the new write and only performs one write transaction (write combine).
- If write combine is disabled, the DDRC follows the following sequence of operations:
 - Holds the new write transaction in a temporary buffer
 - Applies flow control back to the core to prevent more transactions from arriving
 - Flushes the internal queue holding the colliding transaction until that transaction has been serviced
 - Accepts the new transaction and removes flow control

10.4.10 Credit Mechanism

The DRAM controller employs a credit mechanism to ensure that buffers do not overflow (pending DDR transactions). The interface making the request to the controller can only request commands for which it has been granted credits or open slots in the queues to issue.

Credits are tracked separately for the following three command types:

- High priority reads
- Low priority reads
- Writes

Credits are counted for each command type independently according to the following rules:

- Initially the interface has zero credits.
- Following the de-assertion of reset to the DRAM controller, credits are issued to the interface for each command type. A given credit count increments every time a credit is issued by the DRAM controller, indicated by the assertion of the appropriate *_credit signal on the rising edge of the clock.
- When the credit count is greater than zero, the interface can issue requests of that type to the controller. Each time a request is issued to the controller, the associated credit count is decremented.

10.5 Controller PHY (DDRP)

The DDRP processes read and write requests from the DDRC and translates them into specific signals within the timing constraints of the target DDR memory. The DDRP is composed of functional units including PHY control, master DLL, and read/write leveling logic. The PHY data slice block handles the DQ, DM, DQS, DQ_OE and DQS_OE signals. The PHY control block synchronizes all of the control signals with the DDR_x3 clock.

There are two kinds of DLLs, the master DLL, and the slave DLL. The DLLs are responsible for creating the precise timing windows required by the DDR memories to read and write data. The master DLL measures the cycle period in terms of a number of taps and passes this number through the ratio logic to the slave DLLs. The slave DLLs can be separated on the target die to minimize skew and delay and to account for process, temperature and voltage variations.

Write leveling and read leveling are new functions required for DDR3, DDR3L operation. These functions help automatically determine delay timings required to align data to the optimal window for reliable data capture:

- Read leveling and write leveling for DDR3, DDR3L
- Support for 16- and 32-bit data bus width with one rank
- Optional ECC with a 16-bit data width
- Individual bytes with read data mask bits

10.6 Functional Programming Model

The memory controller has several functional features; their programming is described in this section. Programming for the operational features are described in section [10.9 Operational Programming Model](#). To start operation of the PS DRAM interface, the following sequence of operations must take place:

1. DDR clock initialization
2. DDR I/O buffers (DDR IOB) initialization and calibration
3. DDR controller (DDRC) register programming
4. DRAM reset and initialization
5. DRAM input impedance (ODT) calibration
6. DRAM output impedance (Ron) calibration
7. DRAM Training
 - a. Write leveling
 - b. Read DQS gate training
 - c. Read data eye training

This section is intended for reference and debug purposes only. Generally, programming for steps 1–7 are provided by the Vivado® Design suite.

10.6.1 Clock Operating Frequencies

Prior to DDR initialization, a DDR clock must be active. Both the DDR_2x and DDR_3x clocks must be configured properly. The DDR_3x clock is the clock used by the DRAM and should be set to the desired operating frequency (note that the data rate per bit is twice the operating frequency). The DDR_2x clock is used by the interconnect and is typically set to 2/3 of the operating frequency. The DDR PLL frequency should be set to an even multiple of the operating frequency.

[Table 10-5](#) provides frequency configuration examples assuming a 50 MHz reference clock.

Table 10-5: DDR Clock Operating Frequency

| Operating Frequency | DDR PLL Frequency | DDR_3x Clock Frequency | DDR_2x Clock Frequency | PLL Feedback Divider | DDR_3x Clock Divider | DDR_2x Clock Divider |
|---------------------|-------------------|------------------------|------------------------|----------------------|----------------------|----------------------|
| 525.00 | 1050.00 | 525.00 | 350.00 | 21 | 2 | 3 |
| 400.00 | 1600.00 | 400.00 | 266.67 | 32 | 4 | 6 |

Programming the DDR clock involves the DDR_PLL_CTRL and DDR_CLK_CTRL registers in the SLCR. Refer to the programming example in section 10.9.2 [Changing Clock Frequencies](#). General PLL programming is described in section 25.10.4 [PLLs](#).

In addition to the main DDR clock, a 10 MHz clock is used by the digitally controlled impedance (DCI) function built into the DDR IOB. This clock is configured via the SLCR DCI_CLK_CTRL register.

10.6.2 DDR IOB Impedance Calibration

The DDR IOBs support calibrated drive strength and termination strength using the DCI digitally controlled impedance mode of the IOB. In DDR2/DDR3/DDR3L modes this is used to calibrate termination strength. In LPDDR2 mode this is used to calibrate drive strength. The DCI state machine requires two external pins, VRN and VRP, which are connected to external resistors to V_{CCO_DDR} and ground, respectively. DCI settings are shown in [Table 10-6](#).

Table 10-6: DCI Settings

| DDR standard | Termination Impedance | Drive Impedance | VRN resistor (to V _{CCO_DDR}) | VRP resistor (to ground) |
|--------------|-----------------------|-----------------|---|--------------------------|
| DDR3/DDR3L | 40Ω | N/A | 80Ω | 80Ω |
| DDR2 | 50Ω | N/A | 100Ω | 100Ω |
| LPDDR2 | None | 40Ω | 40Ω | 40Ω |

When enabled, the DCI state machine will automatically match drive and termination impedance to the external resistors. This background calibration takes 1-2 ms to lock and then runs continuously.

Calibration

1. Configure the clock module to configure a 10 MHz clock on dci_clk
2. Enable the DDR DCI calibration system using the SLCR registers DDRIOB_DCI_CTRL and DDRIOB_DCI_STATUS
 - a. Toggle DDRIOB_DCI_CTRL.RESET_B to 0 and set to 1
 - b. Set DDRIOB_DCI_CTRL.PREF_OPT, and NREF_OPT fields according to [Table 10-7](#)
 - c. Set DDRIOB_DCI_CTRL.UPDATE_CONTROL to 0
 - d. Set DDRIOB_DCI_CTRL.ENABLE to 1
 - e. Poll on the DDRIOB_DCI_STATUS.DONE bit until it is 1

Table 10-7: Calibration

| Field Name | Reset | Power Down | DCI Enable DDR3/DDR3L | DCI Enable DDR2 | DCI Enable LPDDR2 | DCI Disabled |
|----------------|-------|------------|-----------------------|-----------------|-------------------|--------------|
| UPDATE_CONTROL | 0 | 0 | 0 | 0 | 0 | 1 |
| PREF_OPT2[2:0] | 000 | 000 | 000 | 000 | 000 | 000 |
| PREF_OPT1[1:0] | 00 | 00 | 00 | 00 | 10 | 00 |
| NREF_OPT4[2:0] | 000 | 000 | 001 | 001 | 001 | 000 |

Table 10-7: Calibration (Cont'd)

| Field Name | Reset | Power Down | DCI Enable DDR3/DDR3L | DCI Enable DDR2 | DCI Enable LPDDR2 | DCI Disabled |
|----------------|-------|------------|-----------------------|-----------------|-------------------|--------------|
| NREF_OPT2[2:0] | 000 | 000 | 000 | 000 | 000 | 000 |
| NREF_OPT1[1:0] | 00 | 00 | 00 | 00 | 10 | 00 |

10.6.3 DDR IOB Configuration

The DDR IOBs must be configured to function as I/O. Each type of DDR IOB is controlled by two different SLCR configuration registers. The configuration registers configure the IOB's input mode, output mode, DCI mode, and other functions.

Configuration

The DDR system supports DDR3L/DDR3/DDR2/LPDDR2 in 16 and 32 bit modes and power down modes. The registers identified in Table 10-8 control groups of I/Os and must be configured depending on the particular mode.

Table 10-8: DDR IOB Configuration Registers

| Register | Affected I/O Blocks | Description |
|------------------------------|--|--|
| DDRIOB_DDR_CTRL | VREF, VRN, VRP, DRST | Controls special I/O modes for internal and external VREF and DCI reference pins VRN and VRP |
| DDRIOB_DCI_CTRL | DCI controller | Enables the DCI controller |
| DDRIOB_DCI_STATUS | DCI controller | Status for the DCI controller |
| DDRIOB_ADDR0 DDRIOB_ADDR1 | DDR_A[14:0], DDR_CKE, DDR_BA[2:0], DDR_ODT, DDR_WE_B, DDR_CAS_B, DDR_RAS_B, DDR_CS_B | Configuration settings for address and control outputs used by LPDDR2, DDR2 and DDR3/DDR3L |
| DDRIOB_CLOCK | DDR_CK_P, DDR_CK_P | Configuration settings for the differential clock outputs. Controls DDR_CK_P, DDR_CK_P |
| DDRIOB_DATA0 | DDR_DQ[15:0], DDR_DM[1:0], DDR_FIFO_IN[0], DDR_FIFO_OUT[0] | Configuration settings for data and mask bits for lower 16-bits |
| DDRIOB_DATA1 | DDR_DQ[31:16], DDR_DM[3:2], DDR_FIFO_IN[1], DDR_FIFO_OUT[1] | Configuration settings for data and mask bits for upper 16-bits |
| DDRIOB_DIFF0 | DDR_DQS_P[1:0], DDR_DQS_N[1:0] | Configuration settings for dqs bits for lower 16-bits |
| DDRIOB_DIFF1 | DDR_DQS_P[3:2], DDR_DQS_N[3:2] | Configuration settings for dqs bits for upper 16-bits |
| DDRIOB_DRIVE_SLEW_ADDR | DDR_A[14:0], DDR_CKE, DDR_BA[2:0], DDR_ODT, DDR_WE_B, DDR_CAS_B, DDR_RAS_B, DDR_CS_B | Drive strength and slew rate settings for address and control output |
| DDRIOB_DRIVE_SLEW_CLOCK | DDR_CK_P, DDR_CK_P | Drive strength and slew rate settings for the clock outputs |
| DDRIOB_DRIVE_SLEW_DATA | DDR_DQ[31:0], DDR_DM[3:0], DDR_FIFO_IN[1:0], DDR_FIFO_OUT[1:0] | Drive strength and slew rate settings for data I/Os |
| DDRIOB_DRIVE_SLEW_DIFF | DDR_DQS_P[3:0], DDR_DQS_N[3:2] | Drive strength and slew rate settings for data strobe I/Os |

Set the IOB configuration as follows:

1. Set DCI_TYPE to DCI Drive for all LPDDR2 I/Os.
2. Set DCI_TYPE to DCI Termination for DDR2/DDR3/DDR3L bidirectional I/Os.
3. Set OUTPUT_EN = obuf to enable outputs.
4. Set TERM_DISABLE_MODE and IBUF_DISABLE_MODE to enable power saving input modes. The TERM_DISABLE_MODE and IBUF_DISABLE_MODE fields should not be set before DDR training has completed.
5. Set INP_TYPE to V_{REF} based differential receiver for SSTL, HSTL for single ended inputs.
6. Set INP_TYPE to Differential input receiver for differential inputs.
7. Set TERM_EN to enabled for DDR3/DDR32L and DDR2 bidirectional I/Os (Outputs and LPRDDR2 IOs are not terminated).
8. Set DDRIOB_DATA1 and DDRIOB_DIFF1 registers to power down if only 16 bits of DQ DDR are used (including ECC bits).
9. For DDR2 and DDR3/DDR3L – DCI only affects termination strength, so address and clock outputs do not use DCI.
10. For LPDDR2 – DCI affects drive strength, so all I/Os use DCI.

VREF Configuration

DDR I/Os use a differential input receiver. One input to this receiver is connected to the data input, and the other is connected to a voltage reference called V_{REF} . For DDR2/3 and LPDDR2 DRAM interfaces, the V_{REF} voltage is set to half of the I/O V_{CCO} voltage. The V_{REF} can be supplied either externally over dedicated V_{REF} pads, or from an internal voltage source. External V_{REF} is recommended for all designs to provide additional timing margin, but requires external board components. To configure the V_{REF} reference supply, set the DDRIOB_DDR_CTRL register as follows:

- To enable internal V_{REF}
 - Set DDRIOB_DDR_CTRL.VREF_EXT_EN to 00 (disconnect I/Os from external signal)
 - Set DDRIOB_DDR_CTRL.VREF_SEL to the appropriate voltage setting depending on the DDR standard ($V_{REF}=V_{CCO_DDR}/2$)
 - Set DDRIOB_DDR_CTRL.VREF_INT_EN to 1 to enable the internal V_{REF} generator
- To enable external V_{REF}
 - Set DDRIOB_DDR_CTRL.VREF_INT_EN to 0 to disable the internal V_{REF} generator
 - Set DDRIOB_DDR_CTRL.VREF_SEL to 0000
 - Set DDRIOB_DDR_CTRL.VREF_EXT_EN to 11 to connect the IOBs V_{REF} input to the external pad for a 32-bit interface
 - Set DDRIOB_DDR_CTRL.VREF_EXT_EN to 01 to connect the IOBs V_{REF} input to the external pad for a 16-bit interface

10.6.4 DDR Controller Register Programming

Prior to enabling the DDRC, all DDRC registers must be initialized to system-specific values. About 80 registers with over 350 parameters might be set or left at their power-on default values. The DDRC is then enabled, by writing to the `ddrc_ctrl` register. Once enabled, the DDRC automatically performs the initialization steps 4-7 ([Functional Programming Model](#)). DDRC operation is autonomous, requiring no further programming unless functionality changes are desired (e.g. changing AXI port priority levels).

10.6.5 DRAM Reset and Initialization

The DDRC performs DRAM reset and initialization per the JEDEC specs, including reset, refresh, and mode registers initialization.

10.6.6 DDR Initialization Sequence

LPDDR2 Initialization Sequence

When used with LPDDR2 DRAM, the initialization state machine executes the following initialization sequence:

1. Power up VDD and VDDQ simultaneously. Assert and hold CKE.
2. Apply stable clock
3. Issue NOP/Deselect for duration specified by `reg_ddrc_pre_cke_x1024` (spec requires at least 200 us with stable power and clock).
4. Issue REFRESH
5. Issue REFRESH
6. Load Mode Register
7. Load Extended Mode Register
8. Issue ACTIVE command
9. Issue deselect for `reg_ddrc_final_wait_x32` cycles (no spec requirement).
10. Begin normal operation

DDR2 Initialization Sequence

For DDR2, the initialization state machine executes the following initialization sequence:

1. Power up
2. Issue NOP/Deselect for duration specified by `reg_ddrc_pre_cke_x1024` (spec requires at least 200 us with stable power and clock)
3. Assert CKE and issue NOP/Deselect for `reg_ddrc_post_cke_x1024` (spec requires at least 400 ns)
4. Issue PRECHARGE ALL followed by NOP/Deselect for `reg_ddrc_t_rp` cycles
5. Program EMR2 to the `reg_ddrc_emr2` value followed by NOP/Deselect for `reg_ddrc_t_mrd` cycles

6. Program EMR3 to the `reg_ddrc_emr3` value followed by NOP/Deselect for `reg_ddrc_t_mrd` cycles
7. Enable DLL by programming EMR to the `reg_ddrc_emr` value followed by NOP/deselect for `reg_ddrc_t_mrd` cycles
8. Issue DLL reset by programming MR to the `reg_ddrc_mr` value followed by NOP/Deselect for `reg_ddrc_t_mrd` cycles
9. Issue Precharge All followed by NOP/Deselect for $(\text{reg_ddrc_t_rp}+1)$ cycles
10. Issue Refresh followed by NOP/Deselect for `reg_ddrc_t_rfc_min` cycles. Repeat 9 times.
11. Program MR without resetting the DLL by setting MR to `reg_ddrc_mr` value with bit 8 set to 1.
12. Issue NOP/Deselect for duration specified by `reg_ddrc_pre_ocrd_x32` (no spec requirement)
13. Issue "OCD complete" command, indicating that no on-chip driver calibration will be performed
14. Issue NOP/Deselect for `reg_ddrc_final_wait_x32` cycles (no spec requirement)
15. Begin normal operation

DDR3 Initialization Sequence

For DDR3, the initialization state machine will execute the following initialization sequence:

1. Power up
2. Issue NOP/Deselect for duration specified by `reg_ddrc_pre_cke_x1024` (spec requires at least 200 us with stable power and clock)
3. Assert CKE and issue NOP/Deselect for `reg_ddrc_post_cke_x1024` (spec requires at least 500 us)
4. Issue MRS command to load MR2 with `reg_ddrc_emr2` value, followed by NOP/Deselect for duration of `reg_ddrc_t_mrd`
5. Issue MRS command to load MR3 with `reg_ddrc_emr3`, followed by NOP/Deselect for duration of `reg_ddrc_t_mrd`
6. Issue MRS command to load MR1 with `reg_ddrc_emr`, followed by NOP/Deselect for duration of `reg_ddrc_t_mrd`
7. Issue MRS command to load MR0 with `reg_ddrc_mr`, followed by NOP/Deselect for duration of `reg_ddrc_t_mod`
8. Start counting of `reg_ddrc_t_zq_long_nop`, and issue ZQCL command to start ZQ calibration
9. Wait for `reg_ddrc_t_zq_long_nop` counting to finish. Ensure wait from step 7 is larger than `tDLLK`
10. Begin normal operation

10.6.7 DRAM Input Impedance (ODT) Calibration

The DRAM mode and extended mode set commands are controlled by the `ddrc.DRAM_EMR_MR_reg` and `ddrc.DRAM_EMR_reg` registers. The encoding for these registers can be found in DRAM device data sheets or JEDEC specifications. The register format for of these commands are shown in [Appendix B, Register Details](#).

The on-die-termination (ODT) is available in DDR2 and DDR3/DDR3L devices with the following features:

- In DDR3/DDR3L devices, the ODT value is controlled via Mode register MR1. It can be disabled, or set to one of the following values: 120Ω, 60Ω, or 40Ω.
- In DDR2 devices, the ODT value is controlled via the mode register EMR. It can be disabled, or set to one of the following values: 75Ω, 150Ω, or 50Ω.
- Both DDR2 and DDR3/DDR3L devices have a dedicated ODT input pin that is used to enable the ODT during write operations, and disable it otherwise.

Calibration

DDR3/DDR3L devices provide ODT calibration via the ZQCL and ZQCS commands. The ZQCL (ZQ calibration long) command is issued as part of the DRAM initialization procedure and is used for initial calibration, which takes about 512 DDR_3x clock cycles. The ZQCS (ZQ calibration short) is subsequently issued automatically by the DDRC for minor calibration adjustments. A typical ZQCS interval is 100 ms.

DDR2 (and LPDDR2) devices do not provide ODT calibration.

10.6.8 DRAM Output Impedance (R_{ON}) Calibration

DRAM device MR/EMR registers are controlled via the `ddrc.DRAM_EMR_MR_reg` and `ddrc.DRAM_EMR_reg` registers. MR/EMR encodings can be found in DRAM device data sheets or JEDEC specifications.

The output impedance control feature is available in DDR2, DDR3/DDR3L and LPDDR2 devices.

- In DDR2 devices, the value is controlled via the mode register EMR, and can be set to full strength or reduced strength.
- In DDR3/DDR3L devices, the value is controlled via the mode register MR1, and can be set to one of the following values: 40Ω or 35Ω.
- In LPDDR2 devices, the value is controlled via MR3, and can be set between 34Ω and 120Ω (default value is 40Ω).

Calibration

In DDR3/DDR3L and LPDDR2 devices, the output impedance is calibrated by the same ZQCL/ZQCS commands discussed above.

In DDR2 devices, the DDR2 external calibration procedure (OCD for off-chip driver calibration) is not supported by the DDRC.

10.6.9 DRAM Training

DRAM training includes three steps, executed in the following order:

1. Write leveling
2. Read DQS gate training
3. Read data eye training

Not all DRAM types support all three steps, as detailed below. Each step can be enabled or disabled independently.

If a training step is enabled, the user must provide an initial delay value as a starting point of the automatic training procedure. The value is a rough estimate of the expected delay or skew (see details below) on the system board, minus some margin.

If a training step is disabled, the user must provide a delay value to be used to compensate for the board delay or skew.

There are several possible reasons why the user might choose to disable a training step.

- The step is not supported by the particular DRAM type. For example, write leveling is not supported by DDR2 and LPDDR2.
- Board delays are well-known and operating conditions are such that timing variance is minimal, and training is not required.
- Delay settings are known from previous training events.

Training time is on the order of 1-2 ms at a 500 MHz DRAM clock.

Note: For training to be successful, all of the data signals need to be connected to the DRAM device(s) even when ECC is used (16-bit data, 10-bit ECC).

Write Leveling

| | |
|-----------------|---|
| Goal | Adjust WR DQS relative to CLK |
| Desired Nominal | DQS aligned with clock (0 phase offset) |
| Final Ratio | Equal to the DQS to CLK board delay at the DRAM |
| Initial Ratio | Final value minus 0.5 cycle. If < 0 set to 0. If skew is too small, invert clock. |
| Applies To | DDR3/DDR3L only |

Write leveling is part of the DDR3/DDR3L specification. Due to the fly-by topology recommended for DDR3/DDR3L systems, the clock (CLK) tends to lag relative to write DQS at the DRAM input. In order to align CLK and DQS as required by the DRAM specification, the PHY delays the DQS signal to match the board skew. The write leveling procedure is used to find the required delay.

When write leveling is enabled (via MR1), the DRAM asynchronously feeds back CLK, sampled with the rising edge of DQS, through the DQ bus. The controller repeatedly delays DQS until a transition from 0 to 1 is detected. Write leveling is performed independently for each byte lane. The calibration

logic OR's the DQ bits in a byte to determine the transition because different memory vendors use different bits in a byte as feedback.

The DDRC supports write leveling as part of the initialization procedure. Optionally, write leveling can be disabled and pre-determined delay values can be programmed via registers (required for DDR2 and LPDDR2 where write leveling is not supported).



IMPORTANT: *Successful training depends on providing an approximate minimum DQS to CLK delay value. This value should be estimated based on system board layout as well as package delay information.*

Read DQS Gate Training

| | |
|-----------------|--|
| Goal | Adjust valid RD DQS window. |
| Desired Nominal | Surround the 4 (BL=8) valid DQS pulses |
| Final Ratio | 2 * board delay. Add 0.5 cycle if the clock is inverted |
| Initial Ratio | Final ratio minus 0.125 cycle (0x20 units), but not < 0. |
| Applies To | DDR3/DDR3L, LPDDR2 |

The read DQS gate training is used by the PHY to identify the valid interval of read DQS and capture the read data. It is necessary to align the valid read window to the read data burst and exclude the preamble period and any period during which the DQS signal is tri-stated or driven by the PHY itself.

The DDRC supports read DQS gate training as part of the initialization procedure. Optionally, training can be disabled and pre-determined delay values can be programmed via registers (required for DDR2, where read training is not supported).

Note that when using LPDDR2, with read gate training, automatic training is not recommended. Instead, the following procedure is recommended (Xilinx tools implement this flow):

1. The even byte lanes are trained and the results are recorded by software.
2. The odd byte lanes are trained and the results are recorded by software.
3. The results from 1 and 2 are then applied during DRAM controller initialization, with automatic training disabled.



IMPORTANT: *Successful training depends on providing an approximate minimum Zynq-7000 SoC-to-DRAM board delay value. This value should be estimated based on system board layout.*

Read Data Eye Training

| | |
|-----------------|---|
| Goal | Adjust RD DQS relative to RD data. |
| Desired Nominal | DQS edge in the middle of data eye |
| Final Ratio | Nominal ideal value is 0.25 cycle since at DRAM output DQ and DQS are aligned |

| | |
|---------------|--------------------|
| Initial Ratio | None required |
| Applies To | DDR3/DDR3L, LPDDR2 |

Enabled by the MPR bit-field in MR3, DDR3/DDR3L Read data eye training is done to compensate for possible imbalanced loading on the read path. In this mode, the DRAM outputs a stream of 01010101 in a burst length of 8 bits with a regular memory read command. Given the known data pattern, the memory controller adjusts the internal DQS delay so that DQS edges occur in the middle of the data eye.

The DDRC supports read data eye training as part of the initialization procedure. Optionally, training can be disabled and pre-determined delay values can be programmed via registers (required for DDR2 where read training is not supported).

10.6.10 Write Data Eye Adjustment

There is no DDRC support for write data eye training, i.e., automatic alignment of write data relative to write DQS (recall that write leveling adjusts write DQS relative to CLK). However, manual alignment is possible.

Nominally, write DQS edges should be aligned in the middle of the write data eye at the DRAM inputs. The DDRC PHY provides a user-programmable phase shift value of data relative to DQS. The default nominal value is a 90 degrees phase shift. Given a balanced board design in which the DQ and DQS signals exhibit the same delay and loading, the default value is adequate. Otherwise, the user can provide a different phase shift value. The recommended value based on characterization across PVT is slightly less than 90 degrees, and will be automatically provided by Vivado Design Suite for inclusion into the FSBL or other user code.

10.6.11 Alternatives to Automatic DRAM Training

If for some reason the automatic training is not successful, alternative calibration schemes can also be used.



TIP: Training failures can be detected by performing a simple memory write-read-compare test. Since training is done independently for each byte lane, the memory test should check each data byte independently. In the event of training failure, two possible solutions are proposed here: a semi-automatic and a manual training method. As the method gets more manual, the training time increases. It is therefore recommended to follow this sequence:

1. Try automatic training, verify board measurement-driven initial values
2. If failed, try semi-automatic training
3. If failed, use manual training

Automatic Training

The standard training procedure is described above.

The estimated time for initialization and training is 1-2 ms.

Semi-Automatic Training

This method is useful when system/board delays are known, but PVT timing uncertainty causes the automatic training to fail. Note that only two initial timing parameters are needed to enable successful automatic training:

- Write DQS to CLK skew
- The one-way board delay from Zynq to DRAM

These values are known in this case, but the PHY PVT variations modify these values in an additive fashion. Therefore, given a nominal delay value T , the actual value might be in the range $(T-\delta, T+\delta)$, where δ is the maximum PVT variation.

The semi-automatic training method is performed as follows:

1. Divide the range $(T-\delta, T+\delta)$ into n parts, and thus create $(n+1)$ possible values for each of the two delay parameters.
2. Perform $(n+1)^2$ automatic training procedures and follow each one with a memory test.

For example, for $n=2$, the three data points for each parameter are $T-\delta$, T , and $T+\delta$. Perform nine automatic training procedures and observe the results. For $n=4$, perform 25 tests, etc.

As final parameters, pick the values that are in the center of the successful tests region. Note that each data byte lane (aka data slice) has its own independent parameters, and should be tested independently in the memory tests.

The estimated time for a training iteration is 1-2 ms plus the duration of the memory test. Assuming a simple 1,000 word read-write test and an average access time of 30 cycles, test duration is on the order of 60,000 cycles or about 0.12 ms at 500 MHz. Thus, a 25-iteration semi-automatic training might last 25-50 ms.

Multi-Set Semi-Automatic Training



RECOMMENDED: *Before resorting to manual training, a multi-set semi automatic training method is recommended.*

The DDR PHY contains five adjustable delay elements, four of which are per byte lane (so the actual number of unique adjustable delay elements is 17). Of these five elements, only three are adjusted by the automatic training. These three elements are the write DQS delay, read DQS delay, and read data delay. The remaining two elements are the write data delay, and the control path delay, which take their value from a programmable register, and the value is not adjusted by the automatic training.

The automatic training process varies the delay of those three elements over a wide range, and the semi-automatic procedure increases that range. If both automatic and semi-automatic procedures fail, it is highly likely that one or both of the remaining two delay elements require adjustment.

Therefore, multiple sets of semi-automatic training procedures can be run, each set using different values of the two remaining delay values. Thus we still take advantage of the efficiency of the automatic training, and reduce the total number of experiments compared to all-manual training.

Manual Training

This method is useful when nothing is known, or if the semi-automatic method has failed. In its simplest form, this method consists of:

- Disabling the automatic training
- Performing a manual sweep of all delay parameters over their entire range. For each setting:
 - Initialize the DDRC with training disabled
 - Perform a memory test
- Keeping a scoreboard of results
- Locating the mid-point of all delay parameters (which might be different for each data lane)

The recommended delay increment value per iteration is 1/32 of a clock cycle, thus requiring 32 iterations to cover a one-cycle delay range per parameter.

The estimated time for a manual training iteration is 700 us (500 us are required as part of the DRAM reset/initialization procedure for DDR3/DDR3L) plus the duration of the memory test, or about 0.8 ms. Simplifying assumptions can be used to reduce the search range, but even then the number of iterations might be on the order of 1,000, bringing the manual training time to about one second.

Table 10-9 provides summary of register values involved in manual training. All values are in units of 1/256 of a clock cycles (256 units = 1 clock cycle, 8 units = 1/32 of a clock cycle).

Table 10-9: Manual Training Register Summary

| | Parameter | Register | Nominal Value | Minimum Suggested Search Range |
|---|---|-----------------------------------|---|--------------------------------|
| 1 | Write DQS delay/write leveling | reg_phy_wr_dqs_slave_ratio[9:0] | DQS to DCLK delay | 0 -256 |
| 2 | Write data delay/write data eye adjustment | reg_phy_wr_data_slave_ratio[9:0] | DQS to DCLK delay + 64 | 64-320 |
| 3 | Read DQS gate delay/read DQS gate training | reg_phy_fifo_we_slave_ratio[10:0] | 2 * board delay | 0-512 |
| 4 | Read data to DQS delay/read data eye training | reg_phy_rd_dqs_slave_ratio[9:0] | 53, placing the DQS edges in the middle of the data eye | 0 - 104 ⁽¹⁾ |
| 5 | Control | reg_phy_ctrl_slave_ratio[9:0] | 128 (64 for LPDDR2) | 64-192 (32-96 for LPDDR2) |

Notes:

1. Parameter 4 is an offset value relative to parameter 3.

10.6.12 DRAM Write Latency Restriction

Note that the minimum DRAM write latency supported is 3. This implies that the minimum CAS latency is 4.

10.7 Register Overview

In general, the DDRC registers are static and can only be changed while the DDRC is in reset. However, there is a set of registers labeled as dynamic in their description that can be modified at anytime.

10.7.1 DDRI

Table 10-10 shows an overview of DDRI registers. There are no dynamic bit fields in the DDRI registers.

Table 10-10: DDRI Registers Overview

| Function | Register Name | Description |
|-------------|--------------------------------|--|
| Arbitration | page_mask | Set this register based on the value programmed on the reg_ddrc_addrmap_* registers. Sets the column address bits to 0. Sets the page and bank address bits to 1. This is used for calculating page_match inside the slave modules in Arbiter. The page_match is considered during the arbitration process. This mask applies to 64-bit address and not byte address. Setting this value to 0 disables transaction prioritization based on page/bank match. |
| | axi_priority_{wr,rd}_port{0:3} | See Appendix B, Register Details for descriptions of the eight registers variants. |
| Misc | axi_id | ID and revision information. |

10.7.2 DDRC

Table 10-11 shows an overview of DDRC registers.

Table 10-11: DDRI Registers Overview

| Function | Hardware Register Name | Dynamic Bit Fields | Description |
|-----------------------|------------------------------|---|---|
| Status | mode_sts_reg | ~ | Controller operation mode status |
| Transaction Scheduler | HPR_reg | ~ | HPR queue control |
| | LPR_reg | ~ | LPR queue control |
| | WR_reg | ~ | WR queue control |
| DDR Protocol | DRAM_param_reg0 | [13:6]: t_rfc_min | DRAM parameters 0 |
| | DRAM_param_reg1 | ~ | DRAM parameters 1 |
| | DRAM_param_reg2 | ~ | DRAM parameters 2 |
| | DRAM_param_reg3 | [20:16]: refresh_to_x32 | DRAM parameters 3 |
| | DRAM_param_reg4 | ~ | DRAM parameters 4 |
| | DRAM_odt_reg | ~ | DRAM ODT control |
| | odt_delay_hold | ~ | ODT delay and ODT hold |
| | ctrl_reg1 | [12]: selfref_en [8]: refresh_update_level | Controller 1 |
| | ctrl_reg2 | ~ | Controller 2 |
| | ctrl_reg3 | ~ | Controller 3 |
| | ctrl_reg4 | ~ | Controller 4 |
| | mode_reg_read | ~ | Mode register read data |
| | lpddr_ctrl{0:3} | ~ | lpddr control registers 0 through 3 |
| | dfi_timing | ~ | DFI timing register |
| DDR Refresh | CHE_REFRESH_TIMER01 | ~ | Reserved |
| | CHE_T_ZQ | [16]: dis_auto_refresh | ZQ parameters |
| | CHE_T_ZQ_Short_Interval_Reg | ~ | Misc parameters |
| DDR Init | DRAM_init_param | ~ | DRAM initialization parameters |
| | DRAM_EMR_reg | ~ | DRAM EMR2, EMR3 access |
| | DRAM_EMR_MR_reg | ~ | DRAM EMR, MR access |
| | DRAM_burst8_rdwr | ~ | DRAM burst 8 read/write |
| | DRAM_disable_dq | [1]: dis_dq | DRAM disable DQ |
| Address Mapping | DRAM_addr_map_{bank,col,row} | ~ | Selects the address bits used as DRAM bank, column, or row address bits |

Table 10-11: DDRI Registers Overview (Cont'd)

| Function | Hardware Register Name | Dynamic Bit Fields | Description |
|-----------------|---|-----------------------|---|
| Power Reduction | deep_pwrdown_reg | [0]: deeppowerdown_en | Deep powerdown (LPDDR2) |
| ECC | CHE_ECC_CONTROL | ~ | ECC error clear |
| | CHE_CORR_ECC | ~ | ECC error correction |
| | CHE_UNCORR_ECC _LOG _ADDR _DATA_31_0 _DATA_63_32 _ECC_DATA_71_64 | ~ | ECC unrecoverable error status address data low data middle data high |
| | CHE_ECC_STATS | ~ | ECC error count |
| | ECC_scrub | ~ | ECC mode/scrub |
| | CHE_ECC_CORR_BIT_MASK _31_0 _63_32 | ~ | ECC data mask low high |

10.7.3 DDRP

Table 10-12 shows an overview of DDRP registers.

Table 10-12: DDRP Registers Overview

| Function | Hardware Register Name | Dynamic Bit Fields | Description |
|-------------|--|-------------------------------------|---|
| DDR Control | ddrc_ctrl | []: soft_rstb []: powerdown_en | DDRC control |
| | Two_rank_cfg | []: t_rfc_nom_x32 | Two rank configuration |
| | PHY_Config{0:3} | ~ | PHY configuration register for data slices 0 through 3 |
| | phy_cmd_timeout_rddata_cpt | ~ | PHY command time out and read data capture FIFO |
| Training | phy_{wr,rd,gate}_lvl_fsm | ~ | |
| | phy_init_ratio{0:3} | ~ | PHY initialization ratio register for data slices 0 through 3 |
| | reg_64 reg_65 | ~ | Training control 2 Training control 3 |
| | reg_2c reg_2d | ~ | Training control Misc debug |
| | reg69_6a{0:3} | ~ | Training results for data slices 0 through 3 |
| | reg6e_71{0:3} | ~ | Training results for data slices 0 through 3 |
| DLL | DLL_calib | ~ | DLL calibration |
| | phy_ctrl_sts | ~ | PHY control status, read |
| | phy_ctrl_sts_reg2 | ~ | PHY control status (2), read |
| | phy_dll_sts{0:3} | ~ | Slave DLL results for data slice |
| | dll_lock_sts | ~ | DLL lock status, read |
| | wr_data_slv{0:3} | ~ | PHY write data slave ratio configuration for data slice 0 through 3 |
| | phy_rd_dqs_cfg{0:3} phy_wr_dqs_cfg{0:3} | ~ | PHY read/write DQS Configuration registers for data slice 0 through 3 |
| | phy_we_cfg{0:3} | ~ | PHY FIFO write enable configuration for data slices 0 through 3 |
| Others | phy_rcvr_enable | ~ | PHY Receiver Enable register |
| | phy_dbg_reg | ~ | PHY Debug register |

10.8 Error Correction Code (ECC)

There is optional ECC support in half-bus width (16-bit) data width configuration only.

Externally 26 bits of a DRAM DDR device are required, 16-bits for data and 10 bits for ECC. Each data byte uses an independent 5-bit ECC field. This mode provides single error correction and dual error detection. The ECC bits are interlaced with the data bits and unused bits as shown in [Table 10-13](#).

Table 10-13: ECC Data Bit Assignments

| DRAM DQ pin | Number of Pins | Function |
|-------------|----------------|--|
| DQ[7:0] | 8 | First Data Byte |
| DQ[15:8] | 8 | Second Data Byte |
| DQ[20:16] | 5 | ECC bits associated with first Data Byte |
| DQ[23:21] | 3 | Unused bits. Connect to DRAM for proper initialization purpose |
| DQ[28:24] | 5 | ECC bits associated with second Data Byte |
| DQ[31:29] | 3 | Unused bits. Connect to DRAM for proper initialization purpose |

10.8.1 ECC Initialization

ECC is supported in 16-bit bus mode only. When enabled, a write operation computes and stores an ECC code along with the data, and a read operation reads and checks the data against the stored ECC code. It is therefore possible to receive ECC errors when reading uninitialized memory locations. To avoid this problem, all memory locations must be written before being read. Note that, since ECC is computed and checked over a byte resolution, a read of 1 byte is done to a 16-bit location that has only that byte initialized (second byte of 16-bit location is uninitialized) does not result in an ECC error. The controller only checks ECC on the byte that has been read. Writing to the entire DDR DRAM through the CPU can be time intensive. It may be worthwhile to use a DMA device to generate larger bursts to the DDR controller initialization and offload the CPU. Note that only the Arm CPU and ACP interfaces can access the lowest 512 KB of DDR (see [Table 4-1](#)), CPU software may still need to initialize this region of ECC-based DDR.

Note that while only two data byte lanes are used for actual data, all four lanes are used in ECC mode, and therefore DDR training must be performed on all lanes.

10.8.2 ECC Error Behavior

For correctable ECC errors, there is no error actively signaled via an interrupt or AXI response.

For uncorrectable ECC errors, the controller returns a SLVERR response back to the re-requesting AXI bus master. In both cases, information regarding the error (such as column, row and bank error address, error byte lane, etc.) is logged in the controller register space.

When the controller detects a correctable ECC error, it does the following:

- Sends the corrected data to the core as part of the read data.
- Sends the ECC error information to the register interface for logging.
- Performs a RMW operation to correct the data present in the DRAM (only if ECC scrubbing is enabled (`reg_ddrc_dis_scrub = 0`). This RMW operation is invisible to the core. Only one scrub RMW command can be outstanding in the controller at any time. No scrub is performed on single-bit ECC errors that occur while the controller is processing another scrub RMW.

When the controller detects an uncorrectable error, it does the following:

- Sends the uncorrectable data with an error response to the core. This results in an AXI SLVERR response on the AXI interface along with the corrupted data. An AXI SLVERR response will be returned to the transaction master to be handled – potentially generating L2/DMA interrupts, CPU prefetch/data exceptions, or being forwarded directly to a PL AXI master.
- Sends the ECC error information to the register module for logging.

10.8.3 Data Mask During ECC Mode

ECC is calculated over a byte of data and hence any data byte can be masked if necessary with ECC enabled. This alleviates the need for the controller to perform a RMW operation when byte masking occurs.

10.8.4 ECC Programming Model

The following details the ECC programming requirements. Note that these configurations are in addition to the regular DDR initialization programming. Also note that initialization of the whole DDR space before reading any data from it is recommended, to prevent ECC error generation as a result of accessing uninitialized areas of memory. Refer to section [10.8.1 ECC Initialization](#) section for further details.

Enabling ECC operation (Switching from Non-ECC Mode to ECC Mode)

1. Program `reg_ddrc_soft_rstb` to 0 (resets the controller)
2. Program the ECC mode by programming `reg_ddrc_ecc_mode` to `3'b100`
3. Program `reg_ddrc_dis_scrub` to `1'b0`
4. Program `reg_ddrc_data_bus_width` to `2'b1`
5. Program `reg_ddrc_soft_rstb` to 1 (takes the controller out of reset)

Note that re-initialization of the whole DDR space before reading any data from it is recommended to prevent ECC error generation as a result of accessing uninitialized areas of memory.

Disabling the ECC Operation (Switching from ECC Mode to Non-ECC Mode)

1. Program the `reg_ddrc_soft_rstb` to 0 (resets the controller)
2. Program the ECC mode by programming the `reg_ddrc_ecc_mode` to `3'b000`
3. Program the `reg_ddrc_dis_scrub` to `1'b1`
4. Program the `reg_ddrc_data_bus_width` to `2'b00`

5. Program the `reg_ddrc_soft_rstb` to 1 (takes the controller out of reset)

A sample test program tests the ECC correctable/uncorrectable error detection by inserting error bits into DDR memory is describes in [AR# 58684](#).

Monitoring ECC Status

1. `CHE_CORR_ECC_ADDR_REG_OFFSET` gives the bank/row/column information of the ECC error correction
2. `CHE_UNCORR_ECC_ADDR_REG_OFFSET` gives the bank/row/column information of the ECC unrecoverable error
3. B[0] of `CHE_CORR_ECC_LOG_REG_OFFSET` indicates correctable ECC status
4. B[0] of `CHE_UNCORR_ECC_LOG_REG_OFFSET` indicates uncorrectable ECC status
5. `CHE_ECC_STATS_REG_OFFSET`
 - B[7:0] -> gives the number of uncorrectable errors
 - B[15:8] -> gives the number of correctable errors

Note: `CHE_ECC_STATS_REG_OFFSET` reports the number of burst transactions with correctable and uncorrectable ECC errors observed since the last read of the register.

10.9 Operational Programming Model

The memory controller has several operational features; their programming is described in this section. Programming for the functional features are described in section [10.6 Functional Programming Model](#).

10.9.1 Operating Modes

The operating mode register bits, `mode_sts_reg.ddrc_reg_operating_mode`, can be polled to determine the current mode of operation of the controller. The different modes are:

- 000 – uninitialized. The controller might be in soft reset, or it might be out of soft reset, but DRAM initialization sequence has not yet completed.
- 001 – normal operating mode. The controller is ready to accept read and write requests and the controller can issue reads and writes to DRAM.
- 010 – DRAM is in power down mode.
- 011 – DRAM is in self refresh mode.
- 100 : 111 – For LPDDR2 designs only, indicates DRAM is in deep power down.

10.9.2 Changing Clock Frequencies

The process of changing clock frequencies is as follows:

1. Request the controller to place the DRAM into self refresh mode, by asserting `ctrl_reg1.reg_ddrc_selfref_en`.

2. Wait until `mode_sts_reg.ddrc_reg_operating_mode[1:0] == 11` indicating that the controller is in self refresh mode. In the case of LPDDR2 check that `ddrc_reg_operating_mode[2:0] == 011`.
3. Change the clock frequency to the controller (see [10.6.1 Clock Operating Frequencies](#) and [25.10.4 PLLs](#)).
4. Update any registers which might be required to change for the new frequency. This includes static and dynamic registers. If the updated registers involve any of `reg_ddrc_mr`, `reg_ddrc_emr`, `reg_ddrc_emr2` or `reg_ddrc_emr3`, then go to step 5. Otherwise go to step 6.
5. Assert `reg_ddrc_soft_rstb` to reset the controller. When the controller is taken out of reset, it re-initializes the DRAM. During initialization, the mode register values updated in step 4 are written to DRAM. Anytime after de-asserting reset, go to step 6.
6. Take the controller out of self refresh by de-asserting `reg_ddrc_selfref_en`.

Note: This sequence can be followed in general for changing DDRC settings, in addition to just clock frequencies.

Note: DRAM must be in self refresh mode (see step 1) for DRAM content preservation when the controller is reset.

10.9.3 Power Down

Enable power down mode in the Master Control register, `ddrc_ctrl`. Once enabled, the DDRC automatically puts the DRAM into pre-charge all power down after the programmed number of idle cycles (`DDRC_param_reg1.reg_ddrc_powerdown_to_x32`).

A refresh request brings the DRAM out of power down. It goes back into power down after the idle period.

Any transaction brings the DRAM out of power down automatically.

Clearing the power down enable bit also brings the DRAM out of power down.

10.9.4 Deep Power Down

Note: Deep power down only applies to LPDDR2 mode.

Set `deep_pwrdsn_reg.deeppowerdown_en=1`. The DDRC puts the DRAM into deep power down as soon as the transaction buffers are empty. If transactions keep arriving the DDRC never puts the DRAM into deep power down.

`deep_pwrdsn_reg.deeppowerdown_en` must be reset to 0 to take DRAM out of deep power down mode. During deep power down exit, the controller performs automatic DRAM initialization.

In LPDDR2, once `deep_pwrdsn_reg.deeppowerdown_en` is reset to 0, there is a wait period (determined by register `reg_ddrc_deeppowerdown_to_x1024`) before the DRAM comes out of deep power down. The value from the spec for this register is 500 us.

Note that any command that comes in while the DRAM is in deep power down mode is stored in the CAM and is processed after deep power down exit and DRAM re-initialization.

10.9.5 Self Refresh

Set the Self Refresh Request bit in the Master Control register, `ddrc_ctrl`. The DDRC puts the DRAM into self refresh as soon as the transaction buffers are empty.

Software must ensure that no transactions arrive. If transactions keep arriving the DDRC never puts the DRAM into self refresh.

The first valid transaction brings the DRAM out of self refresh.

10.9.6 DDR Power Reduction

Clock Stop

When this feature is enabled, the DDR PHY is allowed to stop the clocks going to the DRAM. For DDR2 and DDR3/DDR3L this feature is effective in self refresh mode only. For LPDDR2 this feature becomes effective in:

- Idle periods
- Power down mode
- Self refresh mode
- Deep power down mode

Precharge Power Down

When enabled, the DDR memory controller dynamically uses precharge power down mode to reduce power consumption during idle periods. Normal operation continues when a new request is received by the DDRC.

Self Refresh

When enabled the DDRC dynamically puts the DRAM into self-refresh mode during idle periods. Normal operation continues when a new request is received by the DDRC. In this mode DRAM contents are maintained even when the DDRC core logic is fully powered down, thus allowing to stop the DDR2X and DDR3X/DDR3LX clocks. Also the DCI clock, which controls the DDR termination, can be shut down. The power can be further reduced by disabling the DDR I/Os, listed in [Table 10-3, page 297](#). Set `DDRIOB_*.OUTPUT_EN` to 00 to disable the DDR I/Os.

Self Refresh Sequence

To put the DDR memory into self-refresh mode the following sequence can be used. When executing these steps, the executing CPU should be the only still active master, to guarantee that no new requests are issued to the DDR memory. This mode is typically used in sleep mode. Note that in the following sequence, T_{ddr} is the period of the DDR clock.

```
ddrc.ctrl_reg1[reg_ddrc_selfref_en] = 1
ddrc.DRAM_param_reg3 [reg_ddrc_en_dfi_dram_clk_disable] = 1
while (ddrc.mode_sts_reg[ddrc_reg_operating_mode] != 3)
```

```
while (ddrc.mode_sts_reg[ddrc_reg_dbg_hpr_q_depth] ||
       ddrc.mode_sts_reg[ddrc_reg_dbg_lpr_q_depth] ||
       ddrc.mode_sts_reg[ddrc_reg_dbg_wr_q_depth])
    delay(40 * Tddr)
slcr.DDR_CLK_CTRL[DDR_2XCLKACT] = 0
slcr.DDR_CLK_CTRL[DDR_3XCLKACT] = 0
slcr.DCI_CLK_CTRL[CLKACT] = 0
```

To resume normal DDR operation the DDR I/Os must be re-enabled first, if DDR I/Os are disabled. Then the clocks must be re-enabled, making DRAM accessible again and the *clock stop* and *self-refresh* features can be disabled.



IMPORTANT: *Precharge power down and self refresh modes are mutually exclusive and must not be activated at the same time.*

Static Memory Controller

11.1 Introduction

The static memory controller (SMC) can be used either as a NAND flash controller or a parallel port memory controller supporting the following memory types:

- NAND flash
- Asynchronous SRAM
- NOR flash

System bus masters can access the SMC controller as shown in Figure 11-1. The operational registers of the SMC are configured through an APB interface. The memory mapping for the SMC is described in Chapter 4, System Addresses. The SMC handles all commands, addresses, data, and the memory device protocols. It allows the users to access the controller by reading or writing into the operational registers. The SMC is based on Arm's PL353 static memory controller.

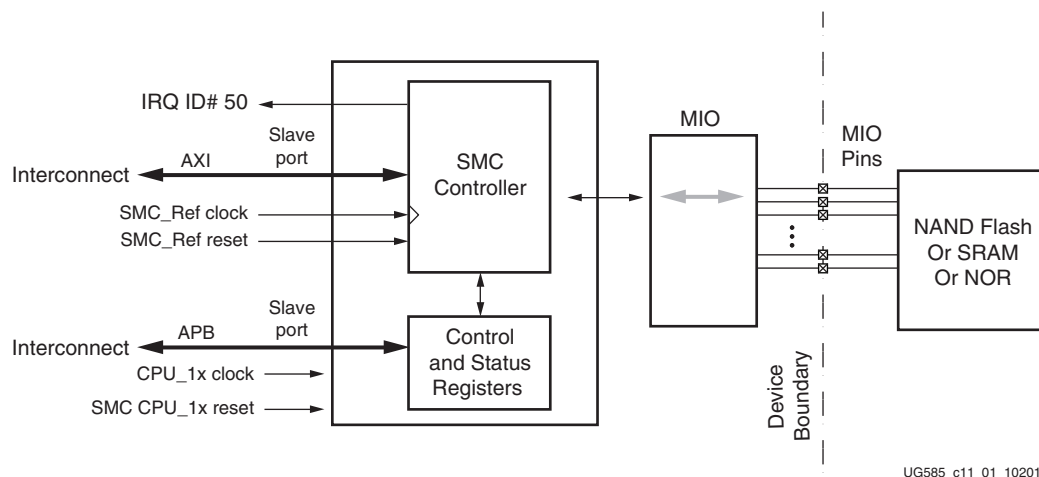

Figure 11-1: SMC System Level Diagram

11.1.1 Features

Features of the SMC are listed for each type of memory. The controller is configured to operate in one of two interface modes.

NAND Flash Interface

- *ONFI Specification 1.0*
- Up to a 1 GB device
 - Because the NAND flash Interface supports only 1-bit ECC and one chip select, the density is limited to 1 GB.
- 8/16-bit IO width with a single chip select
- 16-word read and 16-word write data FIFOs
- 8-word command FIFO
- Programmable IO cycle timing
- 1-bit ECC hardware with software assist
- Asynchronous memory operating mode

Parallel (SRAM/NOR) Interface

- 8-bit data bus width
- One chip select with up to 25 address signals (32 MB)
- Two chip selects with up to 25 address (32 + 32 MB)
- 16-word read and 16-word write data FIFOs
- 8-word command FIFO
- Programmable I/O cycle timing on a per chip select basis
- Asynchronous memory operating mode

11.1.2 Block Diagram

The block diagram for the SMC is shown in Figure 11-2.

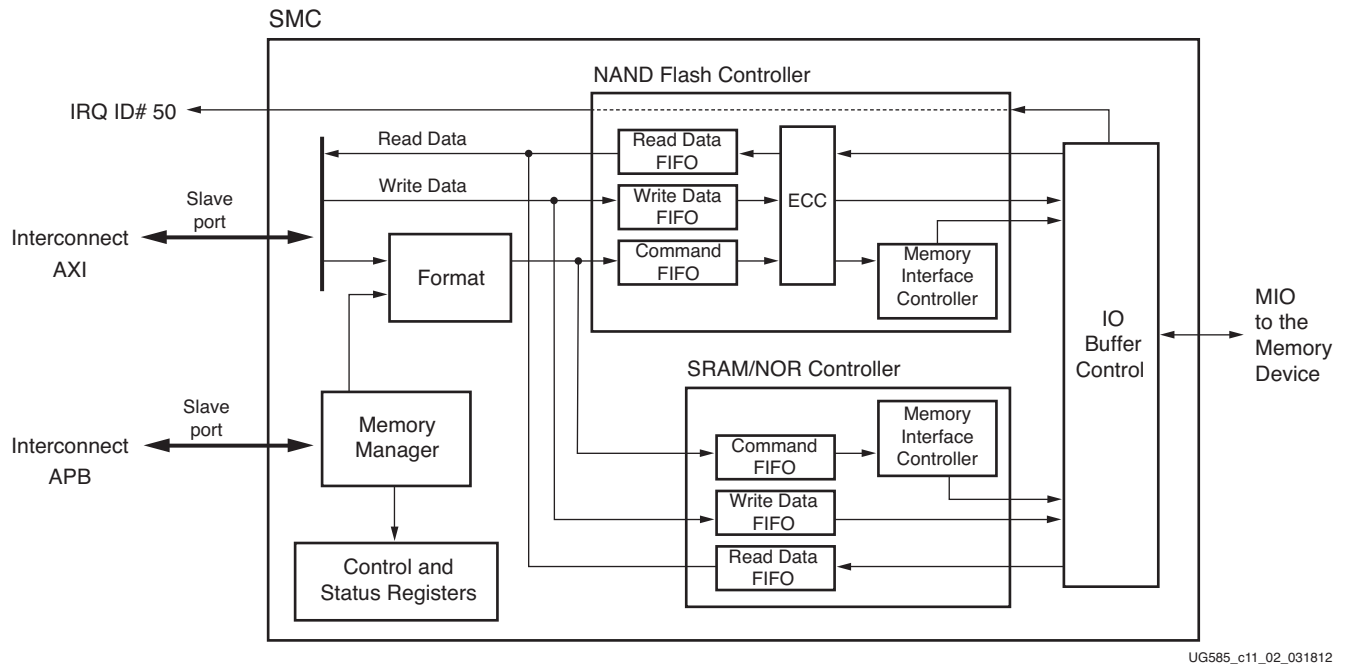

Figure 11-2: SMC Block Diagram

Interconnect Interfaces

For the NOR/SRAM controller mode, the AXI interface is memory mapped so software can read and write to/from memory. For the NAND flash controller mode, software writes commands to the NAND controller via the AXI interface. Details can be found in the Arm specification.

The APB bus interface provides a memory mapped area for the software to read and write the control and status registers.

Memory Manager

The memory manager tracks and controls the current state of the CPU_1x clock domain state machine. This block is responsible for updating register values that are used in the memory clock domain and controlling direct commands issued to memory and controlling entry-to and exit-from low-power mode through the APB interface.

Format

The format block arbitrates between memory accesses from the AXI slave interface and the memory manager. Requests from the manager have the highest priority. Requests from AR and AW channels are arbitrated on a round-robin basis. The format block also maps AXI transfers onto appropriate memory transfers and passes these to the memory interface through the command FIFO.

11.1.3 Notices

7z007s and 7z010 CLG225 Devices

The 7z007s single core 7z010 dual core CLG225 devices do not support the NOR/SRAM interface. The NAND interface is supported in the 8-bit interface, but not the 16-bit interface.

MIO Pin Options

MIO Pin 1 can be programmed to be CS1 or address bit 25 for the NOR/SRAM controller. This pin can also be programmed as a GPIO. Programming is controlled by the `slcr.MIO_PIN_01` register. Program this pin to CS1 when two NOR devices are in the system. Program this pin to address bit 25 when the device is larger than 32 MB, however, its functionality requires one of two work-arounds as described in Xilinx [AR# 60848](#). [Table 11-1](#) summarizes of how the SMC works for NOR/SRAM.

Table 11-1: MIO Pin 1 Programming for the NOR/SRAM Controller

| <code>slcr.MIO_PIN_01</code> {L2_SEL} | Address Accessed | MIO0 | MIO1 |
|--|------------------|------------------------------|-----------------------------------|
| 01 (ADDR25) | 0xe200_0000 | 1->0->1 (acts as active CS0) | 1 (acts as inverted ADDR25) |
| 01 (ADDR25) | 0xe400_0000 | 0 (acts as inactive CS0) | 0 (acts as inverted ADDR25) |
| 10 (CS1) | 0xe200_0000 | 1->0->1 (acts as active CS0) | 1 (acts as inactive CS1) |
| 10 (CS1) | 0xe400_0000 | 1 (acts as inactive CS0) | 1->0->1 (acts as active CS1) |
| 00 (GPIO) | 0xe200_0000 | 1->0->1 (acts as active CS0) | 1 (reset state, internal pull-up) |
| 00 (GPIO) | 0xe400_0000 | 1 (acts as inactive CS0) | 1 (reset state, internal pull-up) |

11.2 Functional Operation

The functional operation of the SMC is described in the *Arm Static Memory Controller (PL350 series) Technical Reference Manual*. Additional information is provided in the following sections.

11.2.1 Boot Device

The NOR and NAND Flash controllers can be configured as a boot device. Its memory interface can only be routed through the MIO.

11.2.2 Clocks

The SMC has two clock domains that are driven by the CPU_1x and SMC_Ref clocks, see [Table 11-2](#). These clocks are controlled by the clock generator, refer to [Chapter 25, Clocks](#). The two clock domains are asynchronous to each other. The main benefit of asynchronous clocking is to maximize the memory performance while running the interconnect interface at a fixed system frequency.



TIP: For power management, the clock enable in the slcr register can be used to turn off the clock. The operating frequency for the reference clock is defined in the data sheet. (Clock gating is used to stop the clock to save power.)

Table 11-2: SMC Clocks and Resets

| Clock | Resets | Clock Domain | Description |
|---------|---------|---------------------|--|
| CPU_1x | CPU_1x | Interconnect domain | This clock runs at 1/6 th or 1/4 th the CPU clock rate depending on the CPU clock mode. To stop this clock, first put the SMC in low-power mode. |
| SMC_Ref | SMC_Ref | SMC domain | This clock is used to control the I/O memory interfaces. |

11.2.3 Resets

The controller has two reset inputs that are controlled by the reset subsystem; refer to [Chapter 26, Reset System](#). This SMC CPU_1x reset is used for the AXI and APB interfaces. The SMC_Ref reset is for the FIFOs and the rest of the controller including the control and status registers.

11.2.4 ECC Support

User code can determine if the NAND device includes on-chip ECC or not by reading the manufacturer and device ID's in the flash device. The supported boot devices are listed in Xilinx [AR50991](#). The vendor specifications for NAND device should be reviewed for ECC support. On-chip ECC errors are flagged using the NAND Interrupt.

When a flash device does not support on-chip ECC, then the 1-bit ECC unit in the SMC controller can be used. Refer to [Arm PrimeCell Static Memory Controller \(PL350 series\) Technical Reference Manual, Revision r2p1](#) for programming information. ECC errors detected by the SMC controller are flagged with the ECC Interrupt.

When programming NAND, the SMC controller adds an inversion of the ECC code if the number of ones (bits=1) in the ECC block (512 bytes = 4096 bits) is odd. To match the hardware behavior, software should add an inversion of the ECC code if the number of ones (bits=1) in the ECC block (512 bytes = 4096 bits) is even.

11.2.5 Interrupts

The controller includes three interrupt sources. These interrupts are controlled by the smc.MEMC_STATUS register. When enabled, the interrupt generates the IRQ ID # 50 signal to the system interrupt controller.

- NAND ECC is triggered by SMC ECC logic.
- NAND Interrupt is triggered on the rising edge of the NAND_BUSY input pin on MIO.
- SRAM Interrupt is triggered on the rising edge of the EMIOSRAMINTIN signal from PL.

The source of the interrupt is determined by reading the smc.MEMC_STATUS register.

11.2.6 PL353 Functionality

The SMC is based on Arm's PL353 Primecell core and is hard-coded such that controller 0 can operate in SRAM/NOR mode and controller 1 can operate in NAND flash mode. The SRAM/NOR or NAND interface can be used in a system, but not both. The SRAM/NOR interface does not support PSRAM. The NAND flash controller does not support wear leveling.

When referencing Arm documentation, for programming and other purposes, refer to the implementation notes in [Table 11-3](#).

Table 11-3: SMC PL353 Implementation Notes

| Parameter | Value | Design Notes |
|-----------------------------|-------|---|
| Chip Selects (Interface 0) | 2 | SRAM/NOR interface chip selects operate independently. |
| Chip Select (Interface 1) | 1 | NAND flash interface chip select |
| NAND flash mode data width | 16 | Data width can be 8 or 16 bits |
| SRAM mode data width | 8 | Data width is 8 bits. |
| System interface bus width | 32 | AXI |
| System interface clock rate | ~ | CPU_1x (1/6 th or 1/4 th the CPU clock frequency) |
| Command FIFO depth | 8 | Maximum supported depth on both interfaces |
| Read data word FIFO depth | 16 | Maximum supported depth on both interfaces |
| Write data word FIFO depth | 16 | Maximum supported depth on both interfaces |
| ECC support | Yes | 1-bit ECC hardware with assistance from software |
| ECC Extra Block | Yes | Supported |
| TCCS | Yes | This field indicates the minimum change column setup time (TCCS) in nanoseconds. After issuing a Change Read Column command, the host shall not read data until a minimum of TCCS time has elapsed. After issuing a change write column command including all column address cycles, the host shall not write data until a minimum of TCCS time has elapsed. The value of TCCS shall always be longer than or equal to TWHR and TADL when the source synchronous data interface is supported. |

Note: Arm's PL353 documentation has a different timing naming convention (used in the SET_CYCLES register) than the ONFI Specification 1.0.

11.2.7 Address Map

The registers and memory base address are listed in [Table 11-4](#).

Table 11-4: SMC Address Map Summary

| Base Address | Mnemonic | Description | Type |
|--------------|----------|--------------------------------------|-----------|
| 0xE000_E000 | SMC | Configuration registers base address | Registers |
| 0xE100_0000 | SMC_NAND | SMC NAND memory base address | Memory |

Table 11-4: SMC Address Map Summary

| Base Address | Mnemonic | Description | Type |
|--------------|-----------|-------------------------------------|--------|
| 0xE200_0000 | SMC_SRAM0 | SMC SRAM Chip Select 0 base address | Memory |
| 0xE400_0000 | SMC_SRAM1 | SMC SRAM Chip Select 1 base address | Memory |

11.3 I/O Signals

The MIO pin assignments for SRAM/NOR and NAND flash connections are shown in Table 11-5. The SMC interface signals are routed only to the MIO pins, they are not available on the EMIO interface. The MIO pins and restrictions (no NOR/SRAM and only 8-bit NAND) are shown in the MIO table in section 2.5.4 MIO-at-a-Glance Table.

Table 11-5: SMC MIO Pins

| MIO Pin | SRAM/NOR Interface Mode | | | | MIO Pin | NAND Flash Interface Mode | | | |
|---------------------------|-------------------------|-----|---------------|---------------------|---------|---------------------------|-----|---------------|---------------------------|
| | Signal Name | I/O | Default Value | Description | | Signal Name | I/O | Default Value | Description |
| MIO Voltage Bank 0 | | | | | | | | | |
| 0 | SRAM_CE_B[0] | O | - | SRAM/NOR chip sel 0 | 0 | NAND_CE_B | O | - | NAND chip select |
| 1 | SRAM_CE_B[1] | O | - | SRAM/NOR chip sel 1 | 1 | - | - | - | - |
| 2 | - | - | - | - | 2 | NAND_ALE | O | - | NAND address latch |
| 3 | SRAM_DQ[0] | IO | 0 | SRAM/NOR data | 3 | NAND_WE_B | O | - | NAND write enable |
| 4 | SRAM_DQ[1] | IO | 0 | SRAM/NOR data | 4 | NAND_IO[2] | IO | 0 | NAND data/address/cmd |
| 5 | SRAM_DQ[2] | IO | 0 | SRAM/NOR data | 5 | NAND_IO[0] | IO | 0 | NAND data/address/cmd |
| 6 | SRAM_DQ[3] | IO | 0 | SRAM/NOR data | 6 | NAND_IO[1] | IO | 0 | NAND data/address/cmd |
| 7 | SRAM_OE_B | O | - | SRAM/NOR output en | 7 | NAND_CLE | O | - | NAND command latch enable |
| 8 | SRAM_BLS_B | O | - | SRAM/NOR write en | 8 | NAND_RE_B | O | - | NAND read enable |
| 9 | SRAM_DQ[6] | IO | 0 | SRAM/NOR data | 9 | NAND_IO[4] | IO | 0 | NAND data/address/cmd |
| 10 | SRAM_DQ[7] | IO | 0 | SRAM/NOR data | 10 | NAND_IO[5] | IO | 0 | NAND data/address/cmd |
| 11 | SRAM_DQ[4] | IO | 0 | SRAM/NOR data | 11 | NAND_IO[6] | IO | 0 | NAND data/address/cmd |
| 12 | - | - | - | - | 12 | NAND_IO[7] | IO | 0 | NAND data/address/cmd |
| 13 | SRAM_DQ[5] | IO | 0 | SRAM/NOR data | 13 | NAND_IO[3] | IO | 0 | NAND data/address/cmd |
| 14 | - | - | - | - | 14 | NAND_BUSY | I | 0 | NAND busy |

Table 11-5: SMC MIO Pins (Cont'd)

| MIO Pin | SRAM/NOR Interface Mode | | | | MIO Pin | NAND Flash Interface Mode | | | |
|---------------------------|-------------------------|-----|---------------|------------------|---------|---------------------------|-----|---------------|-----------------------|
| | Signal Name | I/O | Default Value | Description | | Signal Name | I/O | Default Value | Description |
| 15 | SRAM_A[0] | O | - | SRAM/NOR address | 15 | - | - | - | - |
| MIO Voltage Bank 1 | | | | | | | | | |
| 23:16 | SRAM_A [8:1] | O | - | SRAM/NOR address | 23:16 | NAND_IO [15:8] | IO | 0 | NAND data/address/cmd |
| 39:24 | SRAM_A [24:9] | O | - | SRAM/NOR address | 39:24 | - | - | - | - |

Optional Pins

- For either SRAM or NOR, the upper address bits are optional. When not used, they can be assigned to other functions.

11.4 Wiring Diagrams

The SMC supports the configurations shown in Figure 11-3, Figure 11-4, and Figure 11-5. The NOR/SRAM mode of the SMC can support two devices (NOR and/or SRAM) using chip selects 0 and 1.

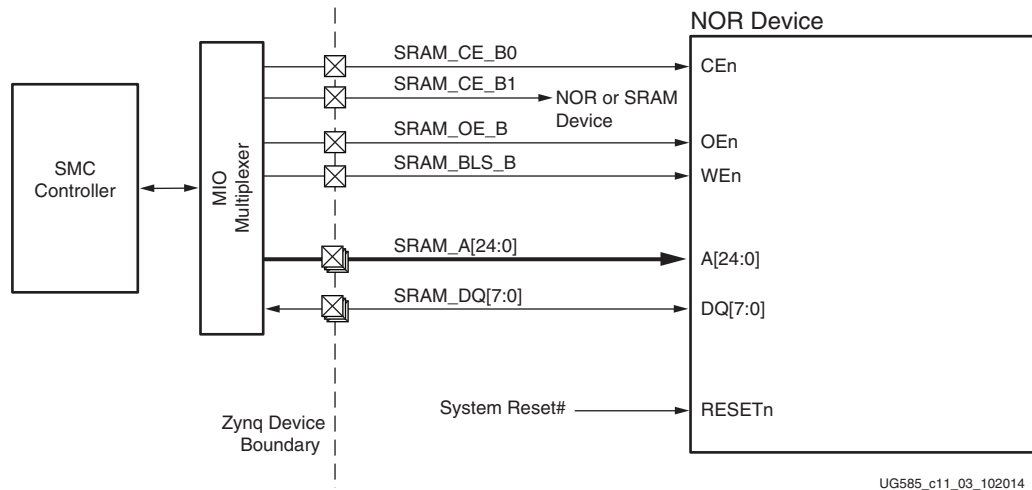

Figure 11-3: NOR Device Wiring Diagram

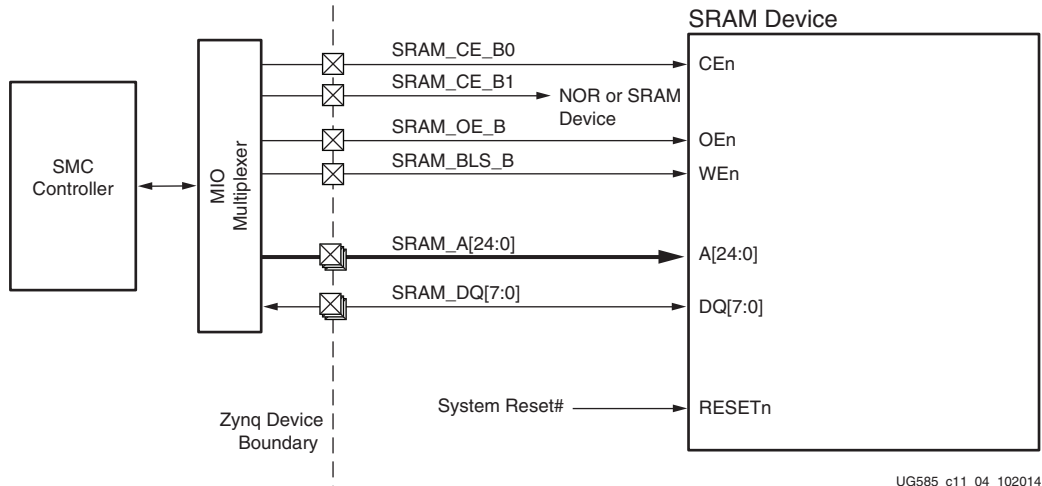

Figure 11-4: SRAM Device Wiring Diagram

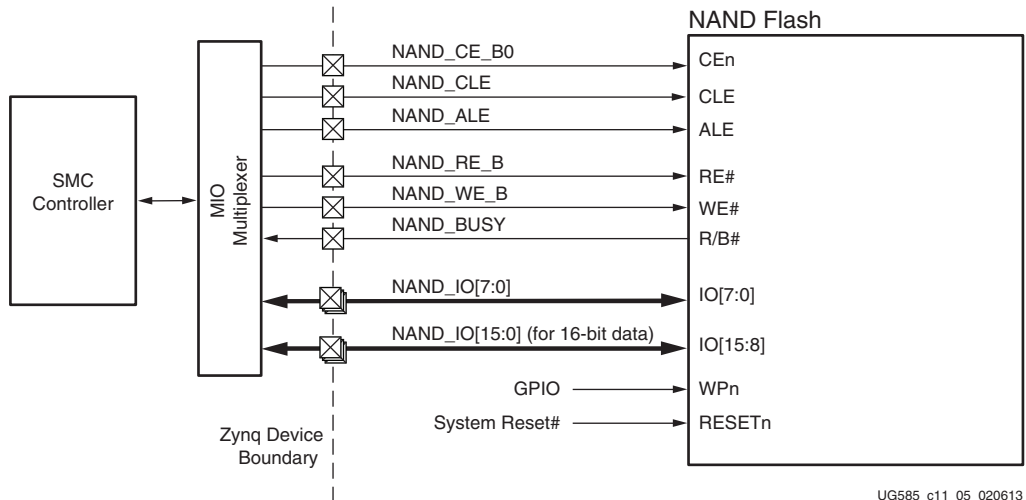

Figure 11-5: NAND Flash Device Wiring Diagram

11.5 Register Overview

The SMC registers are summarized in [Table 11-6](#).

Table 11-6: SMC Register Overview

| Controller | Register Name | Description |
|---------------------|------------------------|---|
| Both | MEMC_STATUS | Operating and interrupt status, read-only |
| | MEMIF_CFG | SMC configuration information, read-only |
| | MEMC_CFG_{SET, CLR} | Enable/disable/clear interrupts and control low power state |
| | DIRECT_CMD | Issue a set command, write-only |
| | SET_{CYCLES, OPMODE} | Stage a cycles or opmode operation to the SRAM/NOR and NAND flash registers |
| | USER_{STATUS, CONFIG} | |
| SRAM/NOR CS 0, 1 | REFRESH_PERIOD_{0,1} | Insert idle cycles between SRAM/NOR burst cycles |
| | SRAM_CYCLES0_{0,1} | Timing cycles |
| | OPMODE0_{0,1} | Operating mode |
| NAND Flash | NAND_CYCLES1_0 | Timing cycles |
| | OPMODE1_0 | Operating mode |
| | ECC_{STATUS, MEMCFG}_1 | ECC status and configuration |
| | ECC_MEMCOMMAND{2:1}_1 | Commands used for ECC reads and writes |
| | ECC_ADDR{1:0}_1 | Address generated by controller |
| | ECC_VALUE{3:0}_1 | Value generated by controller |

11.6 Programming Model

The programming model is described in the *Arm Static Memory Controller (PL350 series) Technical Reference Manual* (see [Appendix A, Additional Resources](#)). The configuration of the SMC is summarized in [Table 11-3](#).

11.7 NOR Flash Bandwidth

The bandwidth measurement details of NOR Flash are:

| | |
|-----------------------------------|---------------|
| Environment: | Standalone |
| NOR flash device used: | PC28F256M29EW |
| SMC (NOR flash controller) clock: | 100 MHz |

| | |
|---------------------|-----------|
| Data transfer size | 1 MB |
| Bandwidth achieved: | |
| Read bandwidth | 9.02 MB/S |
| Write bandwidth | 7.36 KB/S |

Quad-SPI Flash Controller

12.1 Introduction

The Quad-SPI flash controller is part of the input/output peripherals (IOP) located within the PS. It is used to access multi-bit serial flash memory devices for high throughput and low pin count applications.

The controller operates in one of three modes: I/O mode, linear addressing mode, and legacy SPI mode. In I/O mode, software interacts closely with the flash device protocol. The software writes the flash commands and data to the controller using the four TXD registers. Software reads the RXD register that contains the data received from the flash device.

Linear addressing mode uses a subset of device operations to eliminate the software overhead that the I/O mode requires to read the flash memory. Linear Mode engages hardware to issue commands to the flash memory and control the flow of data from the flash memory bus to the AXI interface. The controller responds to memory requests on the AXI interface as if the flash memory were a ROM memory. In legacy mode, QSPI controller acts as a normal SPI controller.

The controller can interface to one or two flash devices. Two devices can be connected in parallel for 8-bit performance, or in a stacked, 4-bit arrangement to minimize pin count. The two device combinations are shown in [Figure 12-1](#).

12.1.1 Features

- 32-bit AXI interface for Linear Addressing mode transfers
- 32-bit APB interface for I/O mode transfers
- Programmable bus protocol for flash memories from Micron and Spansion
- Legacy SPI and scalable performance: 1x, 2x, 4x, 8x I/O widths
- Flexible I/O
 - Single SS 4-bit I/O flash interface mode
 - Dual SS 8-bit parallel I/O flash interface mode
 - Dual SS 4-bit stacked I/O flash interface mode
 - Single SS, legacy SPI interface
- 16 MB addressing per device (32 MB for two devices)

- Device densities up to 128 Mb for I/O and linear mode. Densities greater than 128 Mb are supported in I/O mode.
- I/O mode (flash commands and data)
 - Software issues instructions and manages flash operations
 - Interrupts for FIFO control
 - 63-word RxFIFO, 63-word Tx FIFO
- Linear addressing mode (executable read accesses)
 - Memory reads and writes are interpreted by the controller
 - AXI port buffers up to four read requests
 - AXI incrementing and wrapping address functions

12.1.2 System Viewpoint

The Quad-SPI flash controller is part of the IOP and connects to external SPI flash memory through the MIO as shown in [Figure 12-1](#). The controller supports one or two memories.

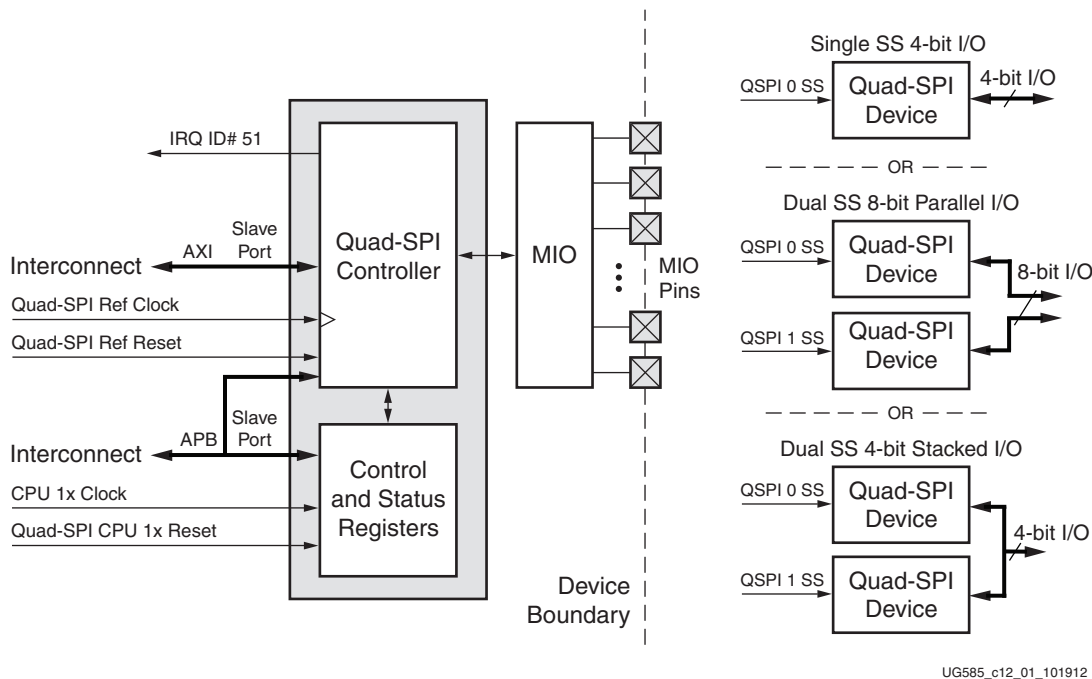

Figure 12-1: Quad-SPI Controller System Viewpoint

Address Map and Device Matching for Linear Address Mode

When a single device is used, the address map for direct memory reads starts at `FC00_0000` and goes to a maximum of `FCFF_FFFF` (16 MB). The address map for a two-device system depends on the memory devices and the I/O configuration. In two-device systems, the Quad-SPI devices need to be from the same vendor so they have the same protocol.

The 8-bit parallel I/O configuration also requires that the devices have the same capacity. The address map for the parallel I/O configuration starts at `FC00_0000` and goes to the address of the combined memory capacities, up to a maximum of `FDFE_FFFF` (32 MB).

For the 4-bit Stacked I/O configuration, the devices can have difference capacities, but must have the same protocol. If using two different size devices, Xilinx recommends using a 128 Mb device at the lower address. In this mode, the QSPI 0 device starts at `FC00_0000` and goes to a maximum of `FCFF_FFFF` (16 MB). The QSPI 1 device starts at `FD00_0000` and goes to a maximum of `FDFE_FFFF` (another 16 MB). If the first device is less than 16 MB in size, then there will be a memory space hole between the two devices.

12.1.3 Block Diagram

The block diagram of the is shown in [Figure 12-2](#).

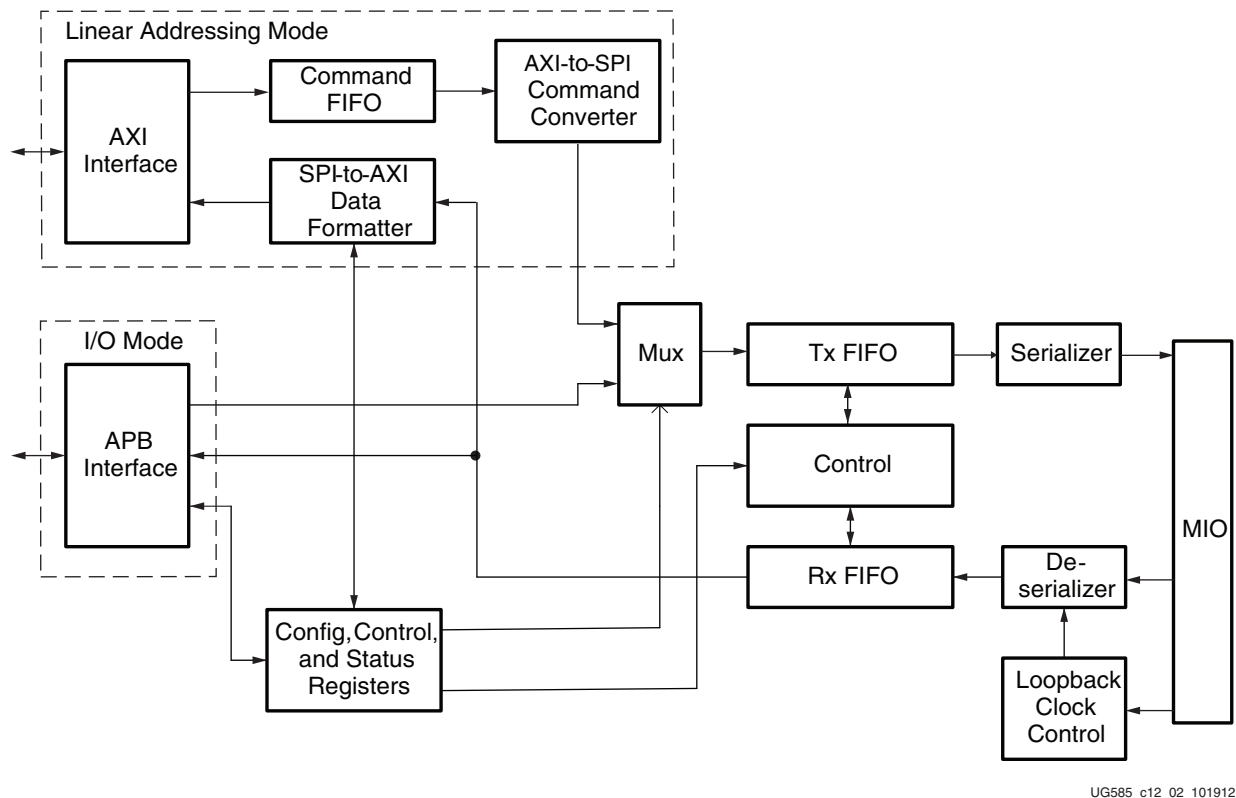

Figure 12-2: Quad-SPI Controller Block Diagram

12.1.4 Notices

Operating Restrictions

When a single device is used, it must be connected to QSPI 0. When two devices are used, both devices must be identical (same vendor and same protocol sequencing).

The MIO pins for the Quad-SPI controller conflict with both the NOR and NAND interfaces of the SMC controller. The NOR/SRAM and NAND interfaces cannot be used when Quad-SPI is used. More information about the MIO pins is provided in section 2.5 PS-PL MIO-EMIO Signals and Interfaces.

12.2 Functional Description

The Quad-SPI flash controller can operate in either I/O mode or linear addressing mode. For reads, the controller supports single, dual and quad read modes in both I/O and linear addressing modes. For writes, single and quad modes are supported in I/O mode. Writes are not supported in linear addressing mode.

12.2.1 Operational Modes

Quad-SPI operating mode transitions are shown in Figure 12-3.

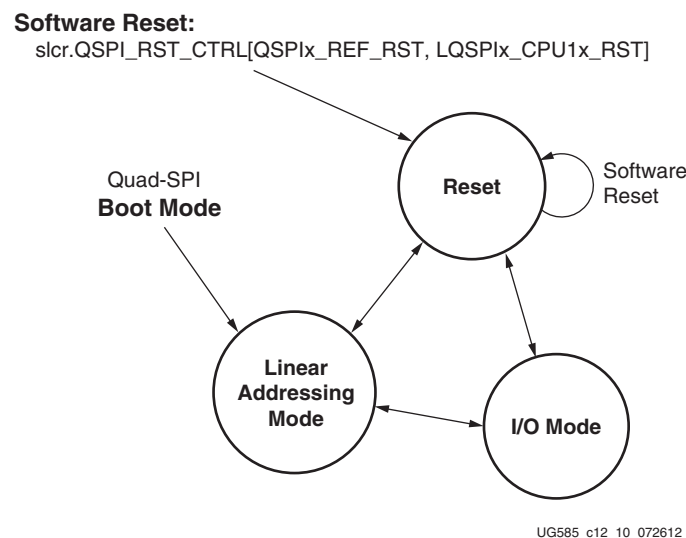

Figure 12-3: Quad-SPI Operating Mode Transitions

In I/O mode, software can choose varying degrees of control over different aspects of read data management by setting appropriate register bits. In linear mode, the controller carries out all necessary read data management and the memory reads like a ROM to software.

12.2.2 I/O Mode

In I/O mode, the software is responsible for preparing and formatting commands and data into instructions according to the Quad-SPI protocol. The formatted instruction sequence, consisting of CMD and data, is then pushed into a transmit FIFO by repeated writing into a TXD register. The transmit logic serializes the content of the TxFIFO in accordance with the Quad-SPI interface specification and send the data out to the flash memory. While the transmit logic is sending out the

content of the TxFIFO, it concurrently samples the raw serial data, performs serial-to-parallel conversion, and stores data into RxFIFO.

In the case of a read command, when data is to be driven by the flash memory after the command and address bytes, the MIO switches from output to input at the appropriate time under the control of the transmit logic. Data shifted into the RxFIFO reflects the switch resulting in valid data in the RxFIFO at the corresponding FIFO entry

Software needs to filter the raw data from the RxFIFO to obtain the relevant data content. The controller does not modify either the instruction written by software or the captured data put into the RxFIFO.

The controller supports little endian mode and the most significant bit of the least significant byte of a 4-byte word of an instruction is sent first.

Flow Control

I/O mode has different modes of flow control during data transfer. The user can select between automatic and manual mode, controlled by config_reg.MANSTARTEN (Man_start_com). In Manual mode, the user can further select manual or automatic chip select with Config_reg.SSFORCE (Manual_CS). Asserting chip select signals the beginning of a command sequence on MIO. Immediately following the CS assertion, serial data on D0 is interpreted as command by the flash memory.

In automatic mode, the entire transmission sequence, including control of chip select is done in hardware. No software intervention is required. The transmission starts as soon as data is pushed into the TxFIFO via writing to TXD, chip select automatically becomes active. Data transmission ends when the TxFIFO is empty and chip select automatically becomes inactive. In this mode, to carry out continuous data transfer, software must be able to keep up with supplying data to the TxFIFO at a rate equal or higher than the rate of data movement on the MIO. This can be difficult since reading from RXD and writing to TXD occurs at the APB clock rate.

In Manual mode, the user controls the start of data transmission. In this case, software either writes the entire transmission sequence to the TxFIFO or until the TxFIFO is full. Upon writing of the Man_start_en bit, the controller takes over, asserts CS, shifts data out of the TxFIFO and into the RxFIFO, controls the input/output state of the MIO as appropriate, and terminates the sequence when the TxFIFO is empty by de-asserting CS. The maximum number of bytes per command sequence in this mode is limited by the depth of the TxFIFO of 252 bytes.

In manual mode, the user can further choose to control the chip select in addition to controlling the start of transmission. Software again writes the transmission sequence to the TxFIFO starting with the command until the TxFIFO is full. Software then asserts CS, followed by manual start. The hardware takes over. However, CS is not de-asserted when the TxFIFO becomes empty. Software can fill the TxFIFO again with the appropriate data to continue the previous command. This method removes the limit on the number of bytes per command sequence and can be used effectively for large data transfers. On completion of the command sequence, the software de-asserts CS by writing to the Manual_CS bit.

12.2.3 I/O Mode Transmit Registers (TXD)

Software writes byte sequences that are needed for the specific flash device. Refer to the Quad-SPI device vendor's specification. The controller has four write-only 32-bit TXD registers for software to issue a stream of commands to get status and read/write data from the flash memory. Quad-SPI TXD register write formats are described in [Table 12-1](#). Each access to the TXD0, TXD1, TXD2, or TXD3 register results into a corresponding write to the TxFIFO.

The user must empty the TxFIFO between consecutive accesses from:

- TXD0 to TXD1/TXD2/TXD3
- TXD1 to TXD0/TXD1/TXD2/TXD3
- TXD2 to TXD0/TXD1/TXD2/TXD3
- TXD3 to TXD0/TXD1/TXD2/TXD3

You need not empty the FIFO for TxD0 to TXD0 accesses.

Table 12-1: Quad-SPI TXD Register Write Formats

| Register | Write Data Format | | | | Example Usage |
|----------|-------------------|----------|----------|-----------------|--|
| | 31:24 | 23:16 | 15:8 | 7:0 | |
| TXD 1 | Reserved | Reserved | Reserved | Data or command | Set write enable |
| TXD 2 | Reserved | Reserved | Data 0 | Data or command | Write status with data |
| TXD 3 | Reserved | Data 1 | Data 0 | Data or command | Read status with two dummy bytes |
| TXD 0 | Data 3 | Data 2 | Data 1 | Data or command | Write data to transmit or dummy data for reads |

Note: The dummy data bytes, which are required in some of the instructions for the selected memory, should be part of the instruction sequence along with the number of bytes intended to be read from memory. The dummy data bytes ensure enough bus turnaround time for switching I/O from output to input. If the number of dummy data bytes is insufficient for an instruction, the memory reads the wrong data. For more information on the number of dummy data bytes needed for a particular instruction, consult the data sheet for the targeted memory.

FIFO Reads and Writes

The TxFIFO and RxTxFIFO share the same gated clock. Therefore for every byte, including command and address bytes shifted out of the TxTxFIFO, a corresponding byte is shifted into the RxTxFIFO

To read data from Quad-SPI flash memory, the software writes the appropriate command, address, mode (when in Quad or Dual I/O mode) and dummy data as required by the Quad-SPI flash memory into the TxTxFIFO. In addition, software must pad the TxTxFIFO with additional dummy data. This additional dummy data provides the CLK needed to shift data into the RxTxFIFO. See section [12.3.5 Rx/Tx FIFO Response to I/O Command Sequences](#) for additional programming details.

12.2.4 I/O Mode Considerations

The Rx FIFO interrupt status bit indicates when data is available before data is actually available for read. The latency is associated with clock domain crossing and is almost always made-up by the time that software takes to service the interrupt.

During a read command, software must write to the Tx FIFO with dummy data to receive data from the device. In automatic mode, if Tx FIFO goes empty, the Quad-SPI controller deasserts chip select. To further receive data, software must send the read command and address to the device.

12.2.5 Linear Addressing Mode

The controller has a 32-bit AXI slave interface to support linear address mapping for read operations. When a master issues an AXI read command through this port, the Quad-SPI controller generates QSPI commands to load the corresponding memory data and send it back through the AXI interface.

In linear mode, the flash memory subsystem behaves like a typical read-only memory with an AXI interface that supports a command pipeline depth of four. The linear mode improves both the user friendliness and the overall read memory throughput over that of the I/O mode by reducing the amount of software overhead. From a software perspective, there is no perceived difference between accessing the linear Quad-SPI memory subsystem and that of other ROMs, except for a potentially longer latency.

Transfer to LQSPI mode happens when the `qspi.LQSPI_CFG.[LQ_MODE]` bit is set to 1. Before entering into linear addressing mode, the user must ensure that both the TX FIFO and RX FIFO are empty. Once the `qspi.LQSPI_CFG.[LQ_MODE]` bit is set, the FIFOs are automatically controlled by the LQSPI module and IO access to TXD and RXD are undefined.

In linear mode the CS pins are automatically controlled by the QSPI controller. Before a transition into LQSPI mode, the user must ensure that `qspi.Config_reg[Man_start_en]` and `qspi.Config_reg[PCS]` are both zero.

A simplified block diagram of the controller showing the linear and I/O portions is shown in [Figure 12-2](#).

AXI Interface Operation

Only AXI read commands are supported by the linear addressing mode. All valid write addresses and write data are acknowledged immediately but are ignored, that is, no corresponding programming (write) of the flash memory is carried out. All AXI writes generate an SLVERR error on the write response channel.

Both incrementing- or wrapping-address burst reads are supported. Fixed-address bursts are not supported and cause an SLVERR error. Therefore, the only recognized `arburst[1:0]` value is either `2'b01` or `2'b10`. All read accesses must be word-aligned and the data width must be 32-bits (no narrow burst transfers are allowed).

Table 12-2 lists the read address channel signals from a master that are ignored by the interface.

Table 12-2: Ignored AXI Read Address Channel Signals

| Signal | Value |
|--------------|---|
| araddr[1:0] | Ignored, assumed to be 0, i.e., always assumed to be word aligned |
| arsize[2:0] | Ignored, always a 32-bit interface |
| arlock[1:0] | Ignored |
| arcache[3:0] | Ignored |
| arprot[2:0] | Ignored |

The AXI slave interface provides a read acceptance capability of 4 so that it can accept up to four outstanding AXI read commands.

AXI Read Command Processing

AXI read burst commands are translated into SPI flash read instructions that are sent to the Quad-SPI controller TxFIFO. The controller transmit logic is responsible for retrieving the read instructions from the FIFO and passing them along to the SPI flash memory according to the SPI protocol.

A 64-deep FIFO is used to provide read data buffering to hold up to four burst-of-16 data. Since the Rx FIFO starts receiving data as soon as the chip-select signal is active, the linear address module removes incoming data that corresponds to the instruction code, if any, the address, the dummy cycles, and responses to the AXI read instruction with valid data.

Interface Configuration and Read Modes

AXI read burst transfers are translated into SPI flash read instructions that are sent to the controller's TxFIFO. The transmit logic retrieves the read instructions from the TxFIFO and passes them to the SPI flash memory device according to the SPI protocol.

Software defines the SPI read command that is used in linear addressing mode by writing to `qspi.LQSPI_CFG[INST_CODE]`. The supported read command codes and the recommended configuration register settings (`qspi.LQSPI_CFG`) are listed in Table 12-3. The optimal register values for Quad-SPI boot performance using a 33 MHz PS_CLK are shown in Table 6-10 and Table 12-3. These Quad-SPI registers can be programmed in non-secure mode using the Register Initialization feature in the BootROM header to speed up loading of the FSBL/User code. If a faster PS_CLK is used, then the clock dividers need to be adjusted.

The choice of operating mode depends on the capabilities of the attached device. The I/O Fast Read modes use 4-bit parallel transfers for address and data. This leads to the fastest performance. The Output Fast Read modes use 4-bit parallel transfers for data only. These are still faster than a serial bit mode.

Table 12-3: Quad-SPI Device Configuration Register Values

| Operating Mode | Instruction Code | Winbond & Spansion | | Micron | |
|------------------------|------------------|--------------------|------------|------------|------------|
| | | 1 Device | 2 Devices | 1 Device | 2 Devices |
| Read (serial bit) | 0x03 | 0x80000003 | 0xE0000003 | 0x80000003 | 0xE0000003 |
| Fast Read (serial bit) | 0x0B | 0x8000010B | 0xE000010B | 0x8000010B | 0xE000010B |
| Dual Output Fast Read | 0x3B | 0x8000013B | 0xE000013B | 0x8000013B | 0xE000013B |
| Quad Output Fast Read | 0x6B | 0x8000016B | 0xE000016B | 0x8000016B | 0xE000016B |
| Dual I/O Fast Read | 0xBB | 0x82FF00BB | 0xE2FF00BB | 0x82FF01BB | 0xE2FF01BB |
| Quad I/O Fast Read | 0xEB | 0x82FF02EB | 0xE2FF02EB | 0x82FF04EB | 0xE2FF06EB |

Performance Modes

To get the highest performance, the user should use the Quad-SPI controller in the Quad I/O mode. The user can improve read performance by using the Quad-SPI device in continuous read mode. This eliminates read instruction overhead for successive commands. Please refer to the LQSPI_CFG register for more details (see [Appendix B, Register Details](#)).

Refer to the applicable Zynq-7000 SoC data sheet for operating frequencies.

Read Data Management

A 63-deep RxFIFO provides read data buffering to hold a minimum of three AXI burst transfer lengths of 16 bytes each. Since the RxFIFO starts receiving data as soon as the chip-select signal is active, the linear address adapter removes incoming data that corresponds to the instruction code, if any, the address, and the dummy cycles.

The read data must be aligned with the corresponding word boundary specified by the address. For data alignment purposes, the controller can modify the address as illustrated in [Figure 12-4](#) before it is sent to the flash memory device. The address modification involves reducing the address by up to 3 byte locations such that the intended return data is word aligned automatically. The amount of address change is transparent to the AXI interface, and is instruction dependent.

For example, if Cmd + address + mode + dummy (QSPI_instruction) does not end on a 32 bit boundary, the linear controller subtracts 1,2,3 from the address to align data on the 32 bit boundary.

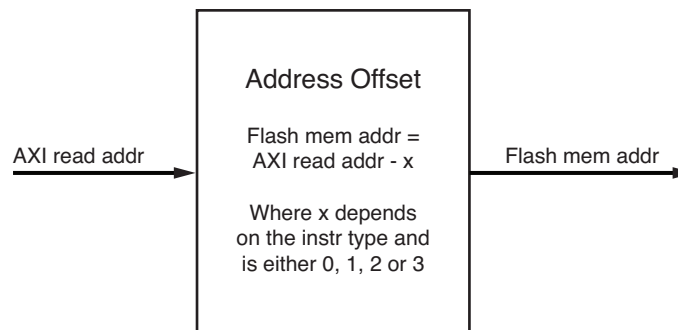

UG585_c12_05_022712

Figure 12-4: Automatic Address Offset For Word Alignment

Read Latency

In linear mode, the default read mode is fast Quad I/O. The following is an example to calculate latency at the memory in the Quad I/O mode at 100 MHz with 2 dummy bytes. For a single device, the number of clock cycles from the time an 8-bit instruction code and a 24-bit address is available to the time when the first 32-bit data becomes available is:

Total latency = instruction latency + address latency + overhead (mode + dummy bites + offset) + latency

$$= 8 \text{ cycles} + 6 \text{ cycles} + 8 (2+4+2) \text{ cycles} + 8 \text{ cycles}$$

$$= 30 \text{ cycles}$$

With the SPI clock of 100 MHz, the latency at the memory interface is 320 ns. Other read modes have higher latency and can be calculated in a similar manner.

12.2.6 Unsupported Devices

A number of devices implement custom 4-bit wide SPI-like interfaces for flash memory access, such as the SQI devices from SST, and the Fast4 devices from Atmel. Some other Quad-SPI devices, like some Micron/Numonyx devices, offer an option to switch operation to such a custom 4-bit interface, through a non-volatile configuration bit.

These interfaces operate differently from the devices supported by the Quad-SPI controller. These flash memory devices operate in 4-bit mode during the instruction phase, as well as the address and data phases. This requires the Quad-SPI flash controller to power up in 4-bit mode and remain in that mode permanently (or until configured otherwise, if that option is available). There are no plans to enable the support for these custom interfaces.

12.2.7 Supported Memory Read and Write Commands

Supports commands that transfers address one bit per rising edge of SCLK and return data 1, 2, or 4 bits of data per rising edge of SCLK from the flash. These commands are called Read or Fast Read for 1-bit data; Dual Output Read for 2-bit data, and Quad Output for 4-bit data.

Supports commands that transfer both address and data 2 or 4 bits per rising edge of SCK. These are called Dual I/O for 2-bit and Quad I/O for 4-bit.

Table 12-4: Memory Read and Write Commands

| Instruction Name | Description | Code(Hex) |
|------------------|--|-----------|
| READ | Read. Single-bit address sent for every rising edge of clock. Data returned one bit per rising edge of SCLK. | 03 |
| FAST_READ | Read Fast. Single-bit address sent for every rising edge of clock. Data returned one bit per rising edge of SCLK. | 0B |
| DOR | Read Dual Out. Single-bit address sent for every rising edge of clock. Data returned two bits per rising edge of SCLK. | 3B |

Table 12-4: Memory Read and Write Commands (Cont'd)

| Instruction Name | Description | Code(Hex) |
|------------------|---|---|
| QOR | Read Quad Out. Single-bit address sent for every rising edge of clock. Data returned four bits per rising edge of SCLK. | 6B |
| DIOR | Dual I/O Read. Two-bit address sent for every rising edge of clock. Data returned four bits per rising edge of SCLK. | BB |
| QIOR | Quad I/O Read. Four-bit address sent for every rising edge of clock. Data returned four bits per rising edge of SCLK. | EB |
| PP | Page Program. Single-bit address sent for every rising edge of clock. Data sent single bit per rising edge of SCLK. | 02 |
| QPP | Quad Page Program. Single-bit address sent for every rising edge of clock. Data sent four bits per rising edge of SCLK. | 32 in case of Spansion and Micron devices. 38 in case of Macronix devices. |

The device switches from dual to quad immediately after command recognition. The number of dummy cycles are frequency and command dependent. Refer to the flash vendor's datasheet for more information.

12.3 Programming Guide

Example: Start-up Sequence

1. **Configure Clocks.** Refer to section [12.4.1 Clocks](#).
2. **Configure Tx/Rx Signals.** Refer to section [12.5.2 MIO Programming](#).
3. **Reset the Controller.** Refer to section [12.4.2 Resets](#).
4. **Configure the Controller.** Refer to section [12.3.1 Configuration](#).

Now, either configure the controller for linear addressing mode (section [12.2.5 Linear Addressing Mode](#)) or configure the controller for I/O mode (section [12.3.3 Configure I/O Mode](#) and section [12.3.4 I/O Mode Interrupts](#)).

12.3.1 Configuration

Example: Configure Controller

This example applies to both linear addressing and I/O modes. It prepares the controller baud rate, FIFO, flash mode, clock phase/polarity, and programs the loopback delay.

The values to program into the `qspi.Config_reg` register are shown in [Table 12-3, page 351](#).

1. **Configure the controller.** Write to the `qspi.Config_reg` register.
 - a. Set baud rate, [BAUD_RATE_DIV].

- b. Select master mode, [MODE_SEL] = 1 .
 - c. Select flash mode (not Legacy SPI), [LEG_FLSH] = 1 .
 - d. Select Little Endian, [endian] = 0.
 - e. Set FIFO width to 32 bits, [FIFO_WIDTH].
 - f. Set clock phase, [CLK_PH] and Polarity, [CLK_POL].
2. **Enable loopback clock.** If the loopback clock is used, ensure qspi.Config_reg[BAUD_RATE_DIV] is set to 0b00 and configure the qspi.LPBK_DLY_ADJ (loopback delay adjustment) register with the following settings:
 - a. **Set to select internal clock.** qspi.LPBK_DLY_ADJ[USE_LPBK] = 1.
 - b. **Set the clock delay 0.** qspi.LPBK_DLY_ADJ[DLY0] = 0b00.
 - c. **Set the clock delay 1.** qspi.LPBK_DLY_ADJ[DLY1] = 0b00.

12.3.2 Linear Addressing Mode

Example: Linear Addressing Mode (Memory Reads)

The sequence of operations for data reads in linear addressing mode is as follows:

1. **Set manual start enable to auto mode.** Set qspi.Config_reg[Man_start_en] = 0.
2. **Assert the chip select.** Set qspi.Config_reg[PCS] = 0.
3. **Program the configuration register for linear addressing mode.** Example values are shown in [Table 12-3, page 351](#).
4. **Enable the controller.** Set qspi.En_REG[SPI_EN] = 1.
5. **Read data from the linear address memory region.** The memory range depends on the size and number of devices. The range is from 0xFC00_0000 up to 0xFDFE_FFFF.
6. **Disable the controller.** Set qspi.En_REG[SPI_EN] = 0.
7. **De-assert chip select.** Set qspi.Config_reg[PCS] = 1.

12.3.3 Configure I/O Mode

Example: I/O Mode (Memory Reads and Writes)

The sequence of operations uses I/O mode for reads and writes.

1. **Enable manual mode.** Write 1 to qspi.Config_reg[Man_start_en, Manual_CS] = 1.
2. **Configure the flash device.** Refer to [Figure 12-6, page 362](#). Use reset values of the qspi.LQSPI_CFG register for a single flash device. In case of a parallel dual flash device, write 1 to the TWO_MEM, SEP_BUS bit fields.
3. **Assert chip select.** Set qspi.Config_reg[PCS] = 0.
4. **Enable the controller.** Set qspi.En_REG[SPI_EN] = 1.
5. **Write byte sequences to the flash memory.** Write from 1 to 4 bytes to the Tx FIFO using the TXD registers. Refer to section [12.2.3 I/O Mode Transmit Registers \(TXD\)](#).

6. **Avoid TxFIFO overflow.** When the TxFIFO is empty, 252 bytes can be written. After that, software can avoid overflowing the TxFIFO by reading `qspi.Intr_status_REG[TX_FIFO_full]` and waiting until it equals 0 before writing to a TXD register.
7. **Enable the interrupts.** Write to `qspi.Intrpt_en_REG`. Interrupt handlers that handle the interrupt conditions are discussed in interrupt handlers section.
8. **Start data transfer.** Set `qspi.Config_reg[Man_start_com] = 1`.
9. **Interrupt handler:** Transfer all the required data to QSPI flash during program/read operations to Quad-SPI flash. (See [Example: I/O Mode Interrupt Service Routine, page 355](#).)
10. **If read operations are carried out:** re-arrange the READ data to eliminate the data read due to dummy cycles.
11. **De-assert chip select.** Set `QSPI.Config_reg[PCS] = 1`.
12. **Disable controller.** Set `qspi.En_REG[SPI_EN] = 0`.

Note that the TxFIFO width must be programmed to 32 bits: `qspi.Config_reg[FIFO_WIDTH] = 0b11`. Software needs to take care of “consecutive non word aligned” transfers.

Example: I/O Mode Interrupt Service Routine

1. **Configure the ISR to handle the interrupt conditions based on the Quad-SPI device type.** To read from the Quad-SPI device, the simplest ISR reads data from the RxFIFO and writes content to the TxFIFO. The system interrupt controller (GIC) is described in [Chapter 7, Interrupts](#). The controller generates a system peripheral interrupt (SPI), IRQ ID #51. The interrupt mechanism for the Quad-SPI controller is described in section [12.3.4 I/O Mode Interrupts](#).
 - a. Read transfer interrupt. RxFIFO Not Empty Interrupt
 - b. Write transfer interrupt. TxFIFO Not Full Interrupt

12.3.4 I/O Mode Interrupts

Interrupts are only used in I/O mode. The controller interrupt is asserted whenever any of the interrupt conditions are met. The Quad-SPI interrupt handler checks the cause of the interrupt. A single interrupt service routine can manage all of the interrupt conditions.

Example: Interrupt Handler for Rx and Tx

The interrupt handler is trigger by IRQ ID #51. The example reads the RxFIFO until it is empty and then fills-up the TxFIFO. The RxFIFO Not Empty Interrupt status is used to determine if content can be read from the RxFIFO. The TxFIFO Not Full interrupt indicates if there is room in the TxFIFO for more content.

1. **Disable all of the interrupts in the controller.** Set `qspi.Intrpt_dis_REG[TX_FIFO_not_full, RX_FIFO_full]` both = 1.
2. **Clear the interrupts.** Write 1s to the interrupt status register `qspi.Intr_status_REG`.
3. **Empty the RxFIFO.** Check if RxFIFO Not Empty interrupt is asserted. If `qspi.Intr_status_REG[RX_FIFO_not_empty] = 1`, then there is data in the RxFIFO.
 - a. **If the status is asserted, then read data from the RxFIFO.** Read the data using the `qspi.RX_data_REG` register.

- b. **Read data from the RxFIFO and poll the interrupt status until the RxFIFO is empty.** The RxFIFO is empty when `qspi.Intr_status_REG[RX_FIFO_not_empty] = 0`.
4. **Fill the TxFIFO.** Check if the TxFIFO Not Full status is asserted. If `qspi.Intr_status_REG[TX_FIFO_not_Full] = 1`, then there is data to be sent to the flash device (program and/or read operations):
 - a. Write data to the `qspi.TXD0` register.
 - b. Poll for `qspi.Intr_status_REG[TX_FIFO_full] = 1`, which indicates TX FIFO is full.
 - c. Follow steps a and b until all the data is written to the TxFIFO or until `qspi.Intr_status_REG[TX_FIFO_full] = 1`.
5. **Enable the interrupts.** Set `qspi.Intrpt_en_REG[TX_FIFO_not_full, RX_FIFO_full]` both = 1.
6. **Start the data transfer.** Set `qspi.Config_reg[MANSTRTEN] = 1`.

Note: There is a delay in updating the QSPI `Intr_status_reg.RX_FIFO_not_empty` bit. This can cause polling software to erroneously assume that there is still data in the RxFIFO when there is none and cause the RxFIFO to under-run. This leads to invalid data being read. To avoid this, software can read the `Intr_status_reg.RX_FIFO_not_empty` bit twice to allow enough time for the controller to update the status bit (see [AR# 47575](#)). The not empty threshold event is detected with a change in the FIFO level as it crosses the threshold, but changing the threshold register to a value to less than the current level does not generate an interrupt.

12.3.5 Rx/Tx FIFO Response to I/O Command Sequences

Example command and sequences:

- Write Enable Command
- Read Status Command
- Read Data Sequence

In these examples, YY can have any value. Each YY pair could have a different value.

To receive data in serial legacy mode, the value is sampled from MISO/DQ1 line into RxFIFO synchronous to clock, while the command and address transactions occur on MOSI/DQ0.

Example: Write Enable Command (code 0x06)

1. **Send the Write Enable Command (WREN).** Write `0xYYYY_YY06` to the `qspi.TXD1` register.
 - a. WREN command = `0x06`.
 - b. YY = 0.
 - c. The controller shifts one byte out of the TxFIFO to the device and receives one byte in the RxFIFO.
2. **Read Status.** Reads the `qspi.RXD` register and receive `0xYYPP_PPPP`.
 - a. Value is `0x0000_0000` when YY = 0x0 (the status) and PP_PPPP = 0x0 (previous state of the bits).
 - b. Software remembers that one byte resulted from the Write Enable command and returns `0xYY` to the calling function.

The content in the RxFIFO after sending the WREN command follows. (Previous means that the value has not changed from the register's previous value.)

| RxFIFO Entry | MSB | | | LSB |
|--------------|---------|----------|----------|----------|
| 1 | Invalid | Invalid | Invalid | Invalid |
| 0 | 00 | Previous | Previous | Previous |

Example: Read Status Command (code 0x05)

1. **Send the Read Status Command (RDSR).** Write 0xYYYY_DD05 to the qspi.TXD2 register.
 - a. Command is 0x05, DD = dummy data, YY = 0
 - b. The controller shifts two bytes out of the TxFIFO to the flash memory and receives two bytes in the RxFIFO.
2. **Read Status Value.** Read 0xZZYY_PPPP from the qspi.RXD register.
 - a. Value is 0x0300_0000 when ZZ = 0x03, YY == 0x0 and PPPP = 0x0.
 - b. Software remembers that two bytes are valid and returns 0x00, 0x03 to the calling function.

The content in the RxFIFO after sending the RDSR command is shown in the table (previous means the value has not changed from the register's previous value):

| TxFIFO Entry | MSB | | | LSB |
|--------------|---------|---------|----------|----------|
| 1 | Invalid | Invalid | Invalid | Invalid |
| 0 | 0x3 | 0x00 | Previous | Previous |

Example: Read Data Sequence

This example returns the four bytes of data at address 0 to the calling function.

1. **Send the data read instruction.** Write 0xA2A1_A003 to the qspi.TXD0 register.
 - a. Instruction includes command (0x03) plus address (A0, A1 and A2).
2. **Send dummy data.** Write 0xD0D1_D2D3 (dummy data) to the qspi.TXD0 register (second TxFIFO entry).
 - a. The controller shifts 8 bytes out of the TxFIFO to the flash memory and receives 8 bytes in the RxFIFO.

The content of the TxFIFO for this example follows. The byte sequence from controller to the device is: 0x03, A0, A1, A2, D0, D1, D2 and D3.

| TxFIFO Entry | MSB | | | LSB |
|--------------|-----|----|----|------|
| 1 | D3 | D2 | D1 | D0 |
| 0 | A2 | A1 | A0 | 0x03 |

3. **Read past the instruction word.** Read the qspi.RXD register and receive 0xYYYY_YYYY:
 - a. YY = 0.
4. **Read flash memory data.** Read the RXD register again and receives 0xD3D2_D1D0.
 - a. For the second read, software remembers that four bytes are valid.
 - b. Example data: 0x2468ACEF.
 - c. Overall, software reads these bytes: 0x00, 0x00, 0x00, 0x00, 0x24, 0x68, 0xAC, 0xEF and returns the four bytes of data to the calling function.

The content of the RxFIFO for this example follows. The byte sequence from the device to controller is: YY, YY, YY, YY, 0xEF, 0xAC, 0x68 and 0x24.

| RxFIFO Entry | MSB | | | LSB |
|--------------|------|------|------|------|
| 1 | 0x24 | 0x68 | 0xAC | 0xEF |
| 0 | YY | YY | YY | YY |

12.3.6 Register Overview

The register overview is provided in [Table 12-5](#).

Table 12-5: Quad-SPI Register Overview

| Address Offset | Mnemonic Software Name | Description |
|----------------|------------------------|--|
| 0x00 | Config_reg | Configuration |
| 0x04 | Intr_status_REG | Interrupt status |
| 0x08 | Intrpt_en_REG | Interrupt enable |
| 0x0C | Intrpt_dis_REG | Interrupt disable |
| 0x10 | Intrpt_mask_REG | Interrupt mask |
| 0x14 | En_REG | Controller enable |
| 0x18 | Delay_REG | Delay |
| 0x1C | TXD0 | Transmit 1-byte command and 3-byte data OR 4-byte data |
| 0x20 | Rx_data_REG | Receive data (RxFIFO) |
| 0x24 | Slave_Idle_count_REG | Slave idle count |
| 0x28 | TX_thres_REG | TxFIFO threshold level (in 4-byte words) |
| 0x2C | RX_thres_REG | RxFIFO Threshold level (in 4-byte words) |
| 0x30 | GPIO | General purpose inputs and outputs |
| 0x38 | LPBK_DLY_ADJ | Loopback master clock delay adjustment |
| 0x80 | TXD1 | Transmit 1-byte command |
| 0x84 | TXD2 | Transmit 1-byte command and 1-byte data |
| 0x88 | TXD3 | Transmit 3-byte 1-byte command and 2-byte data |

Table 12-5: Quad-SPI Register Overview (Cont'd)

| Address Offset | Mnemonic Software Name | Description |
|----------------|------------------------|---------------------------|
| 0xA0 | LQSPI_CFG | Linear mode configuration |
| 0xA4 | LQSPI_STS | Linear mode status |
| 0xFC | MOD_ID | Module ID |

12.4 System Functions

12.4.1 Clocks

The controller and I/O interface are driven by the reference clock (QSPI_REF_CLK). The controller's interconnect also requires an APB interface CPU_1x clock. These clocks are generated by the PS clock subsystem.

CPU_1x Clock

Refer to section 25.2 [CPU Clock](#), for general clock programming information. The CPU_1x clock runs asynchronous to the Quad-SPI reference clock.

QSPI_REF_CLK and Quad-SPI Interface Clocks

The QSPI_REF_CLK is the main controller clock. The QSPI_REF_CLK is sourced from the PS Clock Subsystem. The clock enable, PLL select, and divisor setting are programmed using the slcr.LQSPI_CLK_CTRL register. Refer to section 25.6.3 [SDIO, SMC, SPI, Quad-SPI and UART Clocks](#) to program the QSPI_REF_CLK frequency.

To generate the Quad-SPI interface clock, the QSPI_REF_CLK is divided down by 2, 4, 8, 16, 32, 64, 128, or 256 using the qspi.Config_reg [BAUD_RATE_DIV] bit field.

For power management, the clock enable in the slcr register can be used to turn off the clock. The operating frequency for the reference clock is defined in the data sheet.

Clock Ratio Restriction in Manual Mode

In manual mode, the QSPI_REF_CLK frequency must be of greater than or equal value to that of CPU_1x clock frequency for reliable operation of the controller.

There is no such restriction in automatic mode. The reference clock is divided down by qspi.Config_reg[baud_rate_divisor] to generate the SCLK clock for the flash memory.

Example: Setup Reference Clock

This example assumes the selected PLL (Arm, DDR or IO) is operating at 1000 MHz and the desired Quad-SPI reference clock frequency is 200 MHz.

1. **Select PLL source, divisors and enable.** Write 0x0000_0501 to the slcr.QSPI_CLK_CTRL register.
 - a. Enable the reference clock.
 - b. Divide the I/O PLL clock by 5: DIVISOR = 0x05.
 - c. Select the I/O PLL as the clock source.

Quad-SPI Feedback Clock

The Quad-SPI interface supports an optional feedback clock pin named qspi_sclk_fb_out. This pin is used with the high speed Quad-SPI timing mode, where the memory interface clock needs to be greater than 40 MHz. The feedback signal is received from the internal input from the I/O so MIO pin 8 needs to be programmed and allowed to freely toggle. Refer to optional programming example in section 12.5.2 MIO Programming for instructions on how to program the MIO_PIN_08 register.

When Quad-SPI feedback mode is used, the qspi_sclk_fb_out pin should only be connected to a pull-up or pull-down resistor which is needed to set the MIO voltage mode (vmode).

When operating at a Quad-SPI clock frequency greater than FQSPICLK2, the MIO 8 pin must be programmed as the feedback output clock and the MIO 8 pin must only be connected to a pull-up/pull-down resistor on the PCB for boot strapping.

12.4.2 Resets

The controller has two reset domains: the APB interface and the controller itself. The reset for two domain must be used together. The effects for each reset type are summarized in Table 12-6.

Table 12-6: Quad-SPI Reset Effects

| Name | APB Interface | TxFIFO and Rx FIFO | Protocol Engine | Registers |
|--|---------------|--------------------|-----------------|-----------|
| ABP Interface Reset slcr.LQSPI_RST_CTRL[LQSPI_CPU1X_RST] | Yes | Yes | No | Yes |
| PS Reset Subsystem slcr.LQSPI_RST_CTRL[QSPI_REF_RST] | No | Yes | Yes | No |

Example: Reset the APB Interface and Quad-SPI Controller

1. **Set controller resets.** Write a 1 to the slcr.LQSPI_RST_CTRL[QSPI__REF_RST and LQSPI_CPU1X_RST] bit fields.
2. **Clear controller resets.** Write a 0 to the slcr.LQSPI_RST_CTRL[QSPI__REF_RST and LQSPI_CPU1X_RST] bit fields.

12.5 I/O Interface

12.5.1 Wiring Connections

The I/O signals are available via the MIO pins. The Quad-SPI controller supports up to two SPI flash memories in either a shared or separate bus configuration. The controller supports operation in several configurations:

- Quad-SPI single SS, 4-bit I/O
- Quad-SPI dual SS, 8-bit parallel I/O
- Quad-SPI dual SS, 4-bit stacked I/O
- Quad-SPI single SS, legacy I/O



IMPORTANT: *QSPI 0 should always be present if the QSPI memory subsystem is to be used. QSPI 1 is optional and is only required for the two-memory arrangement. Therefore, QSPI_1 cannot be used alone.*

Single SS, 4-bit I/O

A block diagram of the 4-bit flash memory interface connected to the controller configuration is shown in Figure 12-5. This configuration supports execution-in-place functionality.

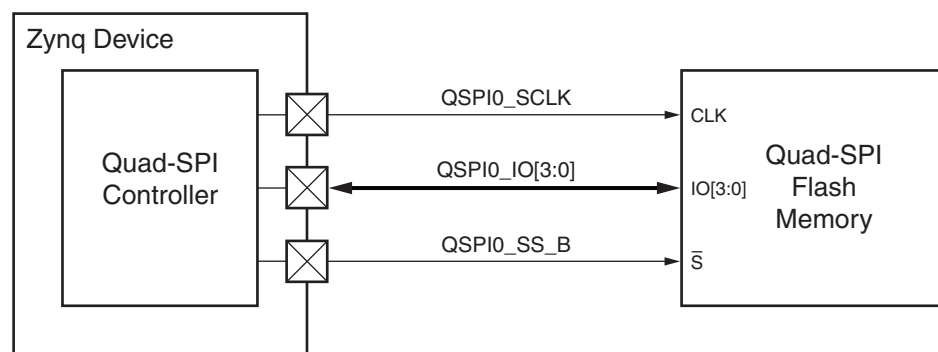

UG585_c12_06_102014

Figure 12-5: Quad-SPI Single SS 4-bit I/O

Dual SS, 8-bit Parallel

The controller supports up to two SPI flash memories operating in parallel, as shown in Figure 12-6. This configuration increases the maximum addressable SPI flash memory from 16 MB (24-bit addressing) to 32 MB (25-bit addressing). The execution-in-place feature is not supported in this configuration.

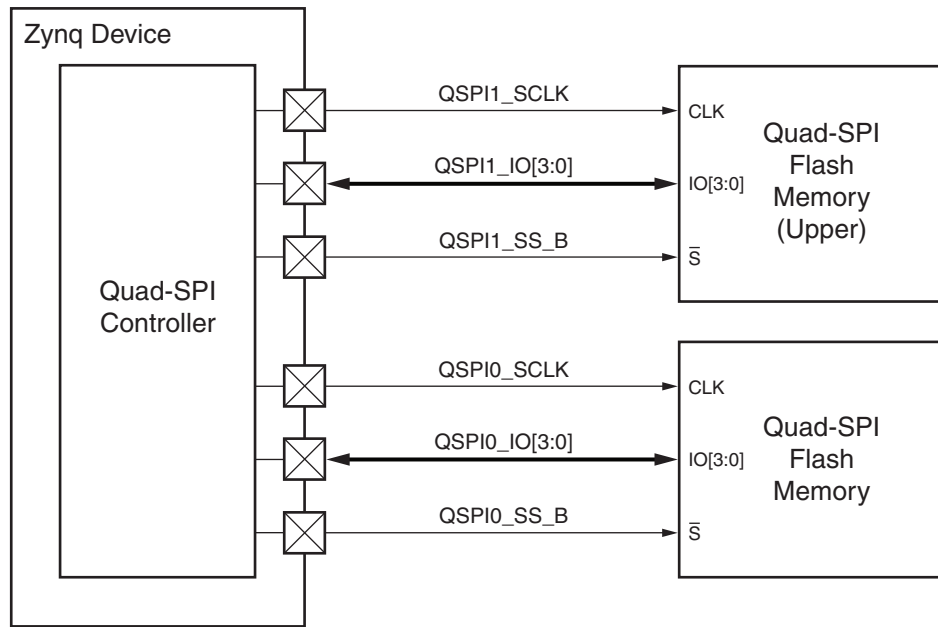

UG585_c12_07_102014

Figure 12-6: Quad-SPI Dual SS, 8-bit Parallel I/O

For 8 bit parallel configuration, even bits of the data words are located in lower memory and odd bits of data are located in upper memory. The controller takes care of data management in both I/O and linear mode. The Quad-SPI controller does a read from the two Quad-SPI devices and ORs (or operation) both device's status information before writing the status data in the RXFIFO. Table 12-7 shows the data bit arrangement of a 32-bit data word for 8 bit parallel configuration. Table 12-8 shows Quad-SPI CMD behavior in Dual Quad-SPI parallel mode.

Table 12-7: Quad-SPI Dual SS, 8-bit Parallel I/O Data Management

| Single Device | | | | | | | | | | | | | | | | | | | | | | | | | | | | | | | |
|---------------|---|---|---|---|---|---|---|--------|----|----|----|----|----|---|---|--------|----|----|----|----|----|----|----|--------|----|----|----|----|----|----|----|
| 7 | 6 | 5 | 4 | 3 | 2 | 1 | 0 | 15 | 14 | 13 | 12 | 11 | 10 | 9 | 8 | 23 | 22 | 21 | 20 | 19 | 18 | 17 | 16 | 31 | 30 | 29 | 28 | 27 | 26 | 25 | 24 |
| byte 0 | | | | | | | | byte 1 | | | | | | | | byte 2 | | | | | | | | byte 3 | | | | | | | |

| Dual Devices Lower Memory | | | | | | | | | | | | | | | |
|------------------------------|---|---|---|----|----|----|---|----|----|----|----|----|----|----|----|
| 6 | 4 | 2 | 0 | 14 | 12 | 10 | 8 | 22 | 20 | 18 | 16 | 30 | 28 | 26 | 24 |

| Dual Devices Upper Memory | | | | | | | | | | | | | | | |
|------------------------------|---|---|---|--------|----|----|---|--------|----|----|----|--------|----|----|----|
| 7 | 5 | 3 | 1 | 15 | 13 | 11 | 9 | 23 | 21 | 19 | 17 | 31 | 29 | 27 | 25 |
| byte 0 | | | | byte 1 | | | | byte 2 | | | | byte 3 | | | |

Table 12-8: Quad-SPI CMD Behavior in Dual Quad-SPI Parallel Mode

| Command | Dual Parallel Quad-SPI Controller Behavior |
|--------------|---|
| Sector Erase | The Quad-SPI controller sends erase command to both chips; 64 KB erase operation is done to each part. Effectively erases combined 128 KB from both memories. |
| Read ID | Only takes received data from the lower flash bus and places it in RXD. Hence no need to combine the data. It is therefore required that the upper and lower flash parts be identical parts when using Parallel Flash Mode. |
| Page Program | Even and odd bits are separated and programmed in both memories. Refer to Table 12-7 for more information. |
| Read | Even and odd data bits are read from both device and are interleaved as shown in Table 12-7 . |
| RDSR | The WIP bit from both parts are OR'ed together to form the LSB .of the data read, the other 7 bits come just from the lower bus. |

In 8 bit parallel configuration, total addressable memory size is 32 MB. This requires a 25-bit address. All accesses to memory must be word aligned and have double-byte resolution. In linear mode, the Quad-SPI controller divides the AXI address by 2 and sends the divided address to the Quad-SPI device. In IO mode, software is responsible for doing the address translation to comply with SPI 24-bit address support.

Dual SS, 4-bit Stacked I/O

To reduce the I/O pin count, the controller also supports up to two SPI flash memories in a shared bus configuration, as shown in [Figure 12-7](#). This configuration increases the maximum addressable SPI flash memory from 16 MB (24-bit addressing) to 32 MB (25-bit addressing), but the throughput remains the same as for single memory mode. Note that in this configuration, the device level XIP mode (read instruction codes of `0xBB` and `0xEB`), is not supported.

The lower SPI flash memory should always be connected if the linear Quad-SPI memory subsystem is used, and the upper flash memory is optional. Total address space is 32 MB with a 25-bit address. In IO mode, the MSB of the address is defined by `U_PAGE` which is located at bit 28 of register `0xA0`. In Linear address mode, AXI address bit 24 determines the upper or lower memory page. All of the commands will be executed by the device selected by `U_PAGE` in I/O mode and address bit 24 in linear mode.

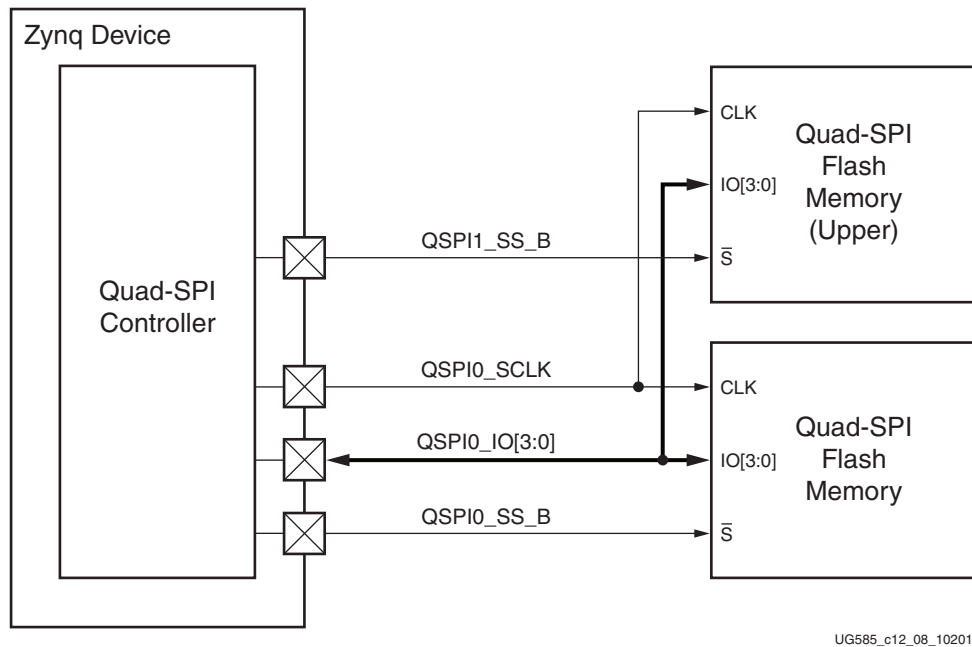

Figure 12-7: Quad-SPI Dual SS 4-bit Stacked I/O

Single SS, Legacy I/O

The Quad-SPI controller can be operated in legacy single-bit serial interface mode for 1x, 2x and 4x I/O modes as shown in Figure 12-8.

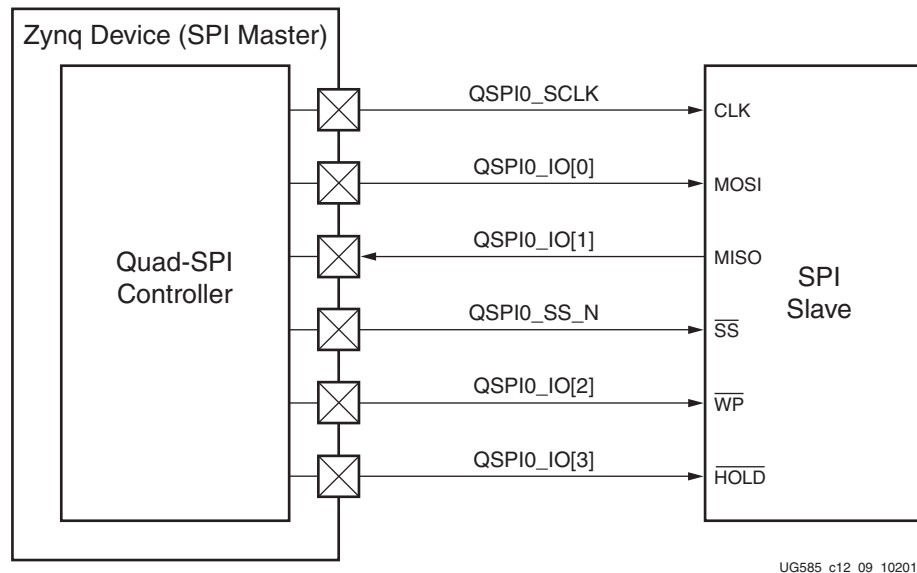

Figure 12-8: Quad-SPI Single SS, Legacy I/O

12.5.2 MIO Programming

The Quad-SPI signals can be routed to specific MIO pins, refer to [Table 12-9](#), Quad-SPI Interface Signals. Wiring diagrams are shown in [Figure 12-5](#) to [Figure 12-8](#). The general routing concepts and MIO I/O buffer configurations are explained in section [2.4 PS-PL Voltage Level Shifter Enables](#).

If a four-bit I/O bus is used, then use Quad-SPI 0. If a bus frequency of greater than 40 MHz is needed, then the Quad-SPI feedback clock must be routed on MIO pin 8.

Example: Program I/O for a Single Device

These steps are required for all of the Quad-SPI I/O interface connections listed above.

- 1. Configure MIO pin 1 for chip select 0 output.** Write `0x0000_1202` to the `slcr.MIO_PIN_01` register:
 - a. Route Quad-SPI 0 chip select to pin 1.
 - b. 3-state controlled by Quad-SPI (`TRI_ENABLE = 0`).
 - c. LVCMOS18 (refer to the register definition for other voltage options).
 - d. Slow CMOS edge (benign setting).
 - e. Enable internal pull-up resistor.
 - f. Disable HSTL receiver (disabled because LVCMOS is selected).
- 2. Configure MIO pins 2 through 5 for I/O.** Write `0x0000_0302` to each of the `slcr.MIO_PIN_{02:05}` registers:
 - a. Route Quad-SPI 0 I/O pins to pin 2 through 5.
 - b. 3-state controlled by Quad-SPI (`TRI_ENABLE = 0`).
 - c. LVCMOS18 (refer to the register definition for other voltage options).
 - d. Slow CMOS drive edge.
 - e. Disable internal pull-up resistor.
 - f. Disable HSTL receiver.
- 3. Configure MIO pin 6 for serial clock 0 output.** Write `0x0000_0302` to the `slcr.MIO_PIN_06` register:
 - a. Route Quad-SPI 0 serial clock to pin 6.
 - b. 3-state controlled by Quad-SPI (`TRI_ENABLE = 0`).
 - c. LVCMOS18 (refer to the register definition for other voltage options).
 - d. Slow CMOS edge (benign setting).
 - e. Disable internal pull-up resistor.
 - f. Disable HSTL receiver.

Option: Add Second Device Chip Select

This step is required for the following I/O connections:

- Dual selects, shared 4-bit data memory interface.

- Dual selects, separate 4-bit data memory interface.
4. **Configure MIO pin 0 for chip select 1 output.** Write `0x0000_1302` to the `slcr.MIO_PIN_00` register:
 - a. Route Quad-SPI 1 chip select to pin 0.
 - b. 3-state controlled by Quad-SPI (`TRI_ENABLE = 0`).
 - c. LVCMOS18 (refer to the register definition for other voltage options).
 - d. Slow CMOS edge (benign setting).
 - e. Enable internal pull-up resistor.
 - f. Disable HSTL receiver.

Option: Add Second Serial Clock

This step is required for the Dual Selects, Separate 4-bit Data Memory Interface:

5. **Configure MIO pin 9 for serial clock 1 output.** Write `0x0000_0302` to the `slcr.MIO_PIN_09` register:
 - a. Route Quad-SPI 1 serial clock to pin 9.
 - b. 3-state controlled by Quad-SPI (`TRI_ENABLE = 0`).
 - c. LVCMOS18 (refer to the register definition for other voltage options).
 - d. Slow CMOS edge (benign setting).
 - e. Disable internal pull-up resistor.
 - f. Disable HSTL receiver.

Option: Add 4-bit Data

These steps are required for the dual selects, separate 4-bit data memory interface:

6. **Configure MIO pins 10 through 13 for I/O.** Write `0x0000_0302` to each of the `slcr.MIO_PIN_{10:13}` registers:
 - a. Route Quad-SPI 1 I/O pins to pin 9 through 13.
 - b. 3-state controlled by Quad-SPI (`TRI_ENABLE = 0`).
 - c. LVCMOS18 (refer to the register definition for other voltage options).
 - d. Slow CMOS drive edge.
 - e. Disable internal pull-up resistor.
 - f. Disable HSTL receiver.

Option: Add Feedback Output Clock

The optional feedback clock is used when the I/O interface is operated above 40 MHz. It should only be connected to a pull-up or pull-down resistor for pin strapping resistor for MIO voltage mode, `vmode`. The feedback clock must also be enabled.

7. **Configure MIO pin 8 for feedback clock.** Write `0x0000_0302` to the `slcr.MIO_PIN_08` register:

- a. Route Quad-SPI feedback clock output to pin 8.
- b. 3-state controlled by Quad-SPI (TRI_ENABLE = 0).
- c. LVCMOS18 (refer to the register definition for other voltage options).
- d. Slow CMOS edge (benign setting).
- e. Disable internal pull-up resistor.
- f. Disable HSTL receiver.

12.5.3 MIO Signals

The Quad-SPI flash memory signals are routed through the MIO multiplexer to the MIO device pins. Each side of the dual controller port can be individually enabled or operate together as an 8-bit I/O interface.

The Quad-SPI flash memory signals are routed to the MIO pins as shown in [Table 12-9](#).

Table 12-9: Quad SPI Interface Signals

| Quad-SPI Flash Memory Interface | | | | MIO Pin | | | | Controller Default Input Value |
|---------------------------------|-------------------|---------------|------------|------------|------------|-----|------------------|--------------------------------|
| Signal | I/O Mode for Data | | | Quad SPI 0 | Quad SPI 1 | I/O | Name | |
| | 1-Bit Data | 2-Bit Data | 4-Bit Data | | | | | |
| Flash Chip Select | ~ | | | 1 | 0 | O | QSPI{1,0}_SS_B | ~ |
| Serial Clock | ~ | | | 6 | 9 | O | QSPI{1,0}_SCLK | ~ |
| Output Feedback Clk | ~ | | | 8 | | O | QSPI_SCLK_FB_OUT | ~ |
| I/O 0 | Master Output | I/O 0 | I/O 0 | 2 | 10 | IO | QSPI{1,0}_IO_0 | 0 |
| I/O 1 | Master Input | I/O 1 | I/O 1 | 3 | 11 | IO | QSPI{1,0}_IO_1 | 0 |
| I/O 2 | Write Protect | Write Protect | I/O 2 | 4 | 12 | IO | QSPI{1,0}_IO_2 | 0 |
| I/O 3 | Hold | Hold | I/O 3 | 5 | 13 | IO | QSPI{1,0}_IO_3 | 0 |

SD/SDIO Controller

13.1 Introduction

The SD/SDIO controller communicates with SDIO devices, SD memory cards, and MMC cards with up to four data lines. On the SD interface, one (DAT0) or four (DAT0-DAT3) lines can be used for data transfer. The SDIO interface can be routed through the MIO multiplexer to the MIO pins or through the EMIO to SelectIO pin in the PL. The controller can support SD and SDIO applications in a wide range of portable low-power applications such as 802.11 devices, GPS, WiMAX, UWB, and others. The SD/SDIO controller block diagram is shown in [Figure 13-1](#).

The SD/SDIO controller is compatible with the standard *SD Host Controller Specification Version 2.0 Part A2* with SDMA (single operation DMA), ADMA1 (4 KB boundary limited DMA), and ADMA2 (ADMA2 allows data of any location and any size to be transferred in a 32-bit system memory - scatter-gather DMA) support. The core also supports up to seven functions in SD1, SD4, but does not support SPI mode. The Zynq-7000 SoC is expected to work with eMMC devices because the protocol is the same as SD, but this has not been extensively verified. Users must be careful to meet all timing requirements as they might or might not comply with eMMC. It does support SD high-speed (SDHS) and SD High Capacity (SDHC) card standards. The user should be familiar with the SD2.0/SDIO 2.0 specifications. These are listed in [Appendix A, Additional Resources](#). The SD/SDIO controller also supports MMC3.31 standard. eMMC flash memories are not primary boot devices for Zynq-7000 family, but can be used as secondary boot devices. For details, refer to [UG821, Zynq-7000 Software Developers Guide](#).

The SD/SDIO controller is accessed by the Arm processor via the AHB bus. The controller also includes a DMA unit with an internal FIFO to meet throughput requirements.

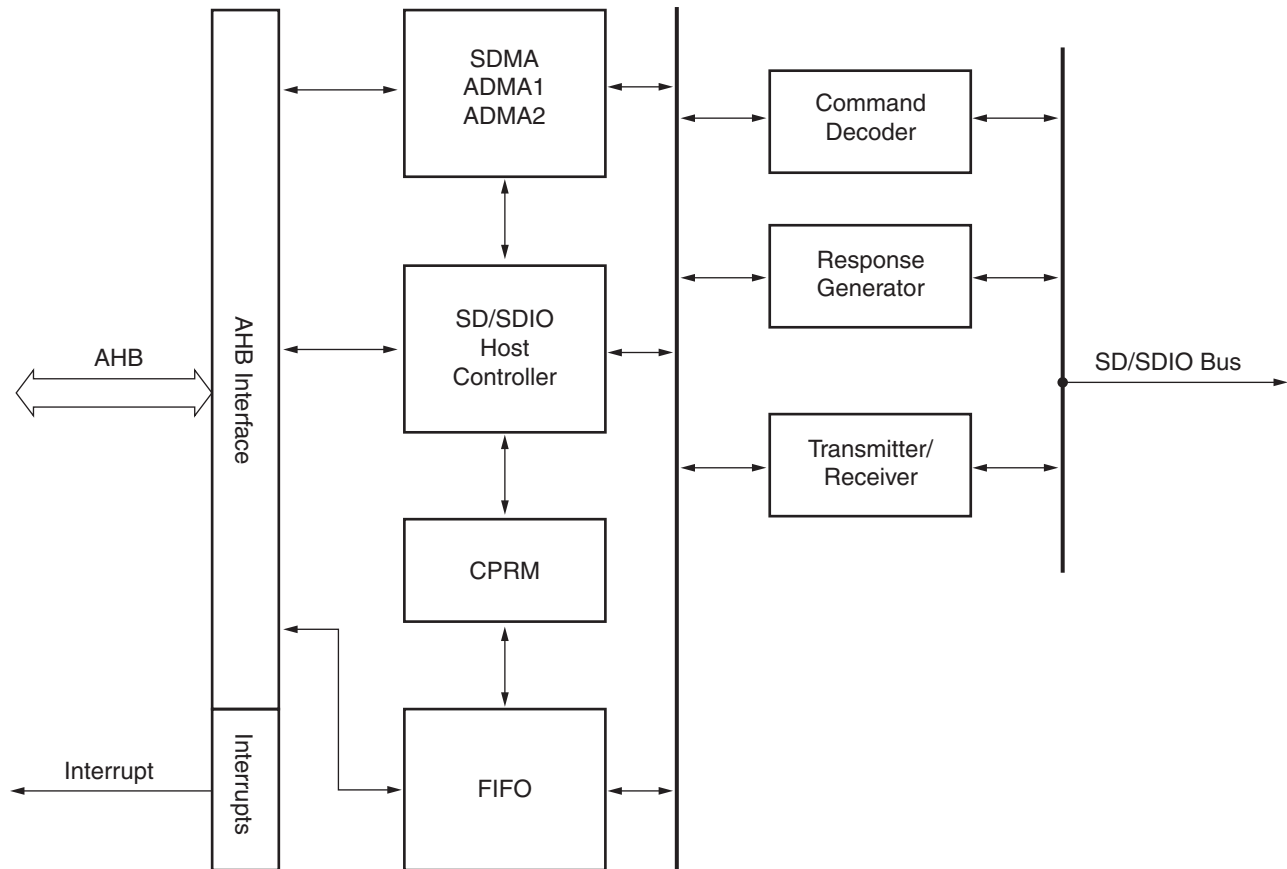

UG585_c13_01_020613

Figure 13-1: SD/SDIO Controller Block Diagram

13.1.1 Key Features

The two SDIO controllers are controlled and operate independently with the same feature set:

- Host mode controller
 - Four I/O signals (MIO or EMIO)
 - Command, Clock, CD, WP, Pwr Ctrl (MIO or EMIO)
 - LED control, bus voltage (EMIO)
 - Interrupt or polling driven
- AHB master-slave interface operating at the CPU_{1x} clock rate

Master mode for DMA transfers (with 1 KB FIFO)

- Slave mode for register accesses
- SDIO Specification 2.0
 - Low-speed, 1 KHz to 400 KHz
 - Full-speed, 1 MHz to 50 MHz (25 MB/sec)
 - High-speed and high-capacity memory cards

13.1.2 System Viewpoint

Figure 13-2 shows the SD/SDIO controller system viewpoint.

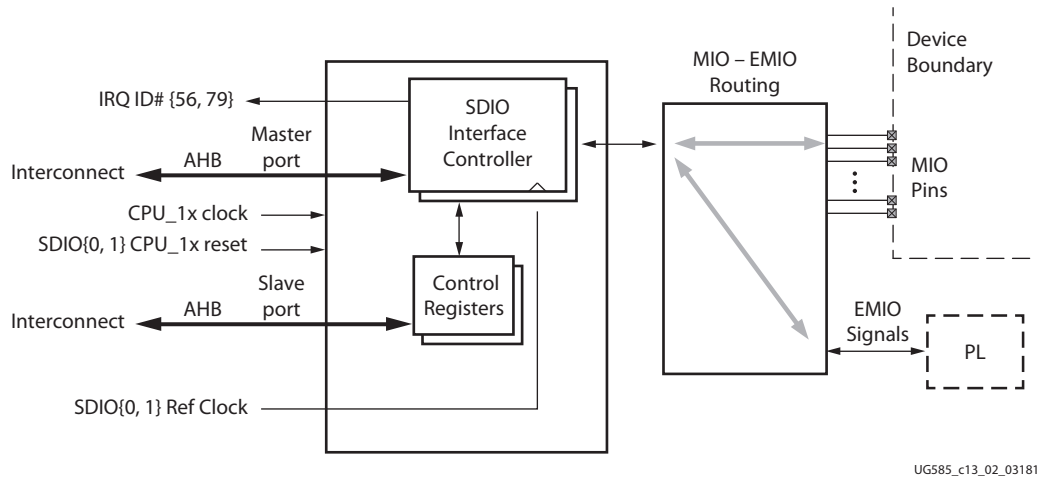

Figure 13-2: SD/SDIO Controller System Viewpoint Diagram

13.2 Functional Description

13.2.1 AHB Interface and Interrupt Controller

When using programmed I/O for data transfers, software reads and writes the `sdio.Buffer_Data_Port` register.

When using the local DMA unit for data transfers, the DMA unit initiates read or write memory transactions. The SDIO controller cannot be used with the PS DMAC.

The controller can generate IRQ interrupt #56 and 79 for SDIO 0 and SDIO 1, respectively. The status and masking of the interrupts are controlled by registers.

13.2.2 SD/SDIO Host Controller

The SD/SDIO host controller comprises:

- Host-AHB controller
- All control registers
- Bus monitor
- Clock generator
- CRC generator and checker (CRC7 and CRC16)

The host-AHB controller acts as bridge between the AHB bus and the host controller. The SD/SDIO controller registers are programmed by the processor through the AHB interface. Interrupts are generated based on the values set in the Interrupt Status and Interrupt Enable registers.

The bus monitor checks for violations occurring on the SD bus and timeout conditions. The clock generation block generates the SD clock depending on the value programmed in the Clock Control register.

The CRC7 and CRC16 generators calculate the CRC for command and data transfers to the SD/SDIO card. The CRC7 and CRC16 checker checks for any CRC errors in the response and data received from the SD/SDIO card. To detect data defects on the card, the host can include error correction codes in the payload data. ECC code is used to store data on the card. This ECC code is used by the application to decode the user data.

13.2.3 Data FIFO

The controller uses two 512 byte dual port FIFOs for performing write and read transactions. During a write transaction (data is transferred from the processor to an attached card) data is written by the processor alternatively into the first and second FIFO. When data is transferred to an attached card, alternatively the second and first FIFO is used, providing maximum data throughput.

During a read transaction (data is transferred from an attached card to the processor) the data from the card is alternatively written in the two FIFOs. When data from one FIFO is transferred to the processor the second FIFO is filled with data from the card and vice versa, optimizing data throughput.

If the controller cannot accept any data from a connected card, it issues a *read wait*, stopping the data transfer from the card by stopping the clock.

13.2.4 Command and Control Logic

The control logic block transmits data on the data lines during a write transaction and receives data during read transaction. The command control logic block transmits commands on the command lines and receives the response from the SD2.0 or SDIO2.0.

13.2.5 Bus Monitor

The bus monitor checks for violations occurring in the SD bus, and timeout conditions.

13.2.6 Stream Write and Read

This functionality applies to both DMA and non-DMA modes.

WRITE_DAT_UNTIL_STOP(CMD20) writes a data stream from the host, starting at the given address, until a STOP_TRANSMISSION follows.

READ_DAT_UNTIL_STOP(CMD11) reads a data stream from the card, starting at the given address, until a STOP_TRANSMISSION follows.

The host controller switches to the second FIFO after writing/reading a block of data to/from the first FIFO, but the stream transaction block size is not be programmed by the driver. So for both stream write and stream read transactions, it is recommended that the host driver writes the maximum FIFO size value to the Block Size register. Because the SDIO FIFO slice is set to 512 bytes, the host driver must write 512 bytes to the Block Size register. Therefore FIFO switching occurs after writing/reading the 512 bytes of data.

13.2.7 Clocks

The SDIO clock is derived from SDIO reference clock based on the Clock Control register value programmed by the driver and is available when the SD clock enable is set by the driver. The maximum frequency is 50 MHz.

The AHB system clock is used for the AHB interface.

The host controller supports both full speed and high speed cards. For the high speed card, the host controller should clock out the data at the rising edge of the SDIO clock. For the full speed card, the host controller should clock out the data at the falling edge of the SDIO clock.

Refer to [Table 24-2, page 671](#) for the more details about power management. Refer to [Chapter 25, Clocks](#) for details about the clocks. Layout and clock termination guidelines are presented in [UG933, Zynq-7000 SoC PCB Design Guide](#).

Note: The SDIO reference clock must be set to more than 100 MHz during the card initialization sequence. This is needed to ensure the SD card interface frequency is no more than 400 kHz as required for initialization. The divisor value is set to $0x80$ (256) yielding a 390 kHz clock from the 100 MHz reference.

13.2.8 Soft Resets

The host controller supports all soft resets mentioned in the *SD2.0/SDIO2.0 Host Controller Specification*.

13.2.9 FIFO Overrun and Underrun Conditions

This functionality applies to both DMA and non-DMA modes.

Write

During the write transaction, the host controller transmits data to the card only when a block of data is ready to transmit and the card is not busy. Therefore an under-run condition cannot occur in the SD side.

- In DMA mode, the host controller initiates a DMA READ from the Arm processor only if space is available to accept a block of data.
- In non-DMA mode, the host controller asserts a buffer write ready interrupt only if space is available to accept a block of data.

Read

During the read transaction when the FIFO is full (the FIFO does not have enough space to accept a block of data from the card) the host controller stops the `clk_sd` to the card. Therefore an over-run condition cannot occur in SD side.

- In DMA mode the host controller initiates a DMA WRITE to the Arm processor only on reception of a block of data from card.
- In non-DMA mode, the host controller asserts a buffer read ready interrupt only on reception of a block of data from card.

Limitation

The interconnect switch (Arm NIC-301) converts the AXI transaction to AHB transaction going to the SD/SDIO Controller. But it does not handle WSTRB signal propagation from the PL. If the PL master issues a 2 byte wide transaction with `AWSIZE=2` (4 bytes), the upper two bytes are undefined. Therefore the recommendation is to use `AxSIZE=1` for 2 byte transfers.

13.3 Programming Model

13.3.1 Data Transfer Protocol Overview

SD transfers are basically classified into following three types according to how the number of blocks is specified:

Single Block Transfer

The number of blocks is specified to the host controller before the transfer. The number of blocks specified is always one.

Multiple Block Transfer

The number of blocks is specified to the host controller before the transfer. The number of blocks specified is one or more.

Infinite Block Transfer

The number of blocks is not specified to the host controller before the transfer. This transfer is continued until an abort transaction is executed. This abort transaction is performed by CMD12 in the case of an SD memory card and by CMD52 in the case of an SDIO card.

13.3.2 Data Transfers Without DMA

Figure 13-3 shows data transfers without using DMA.

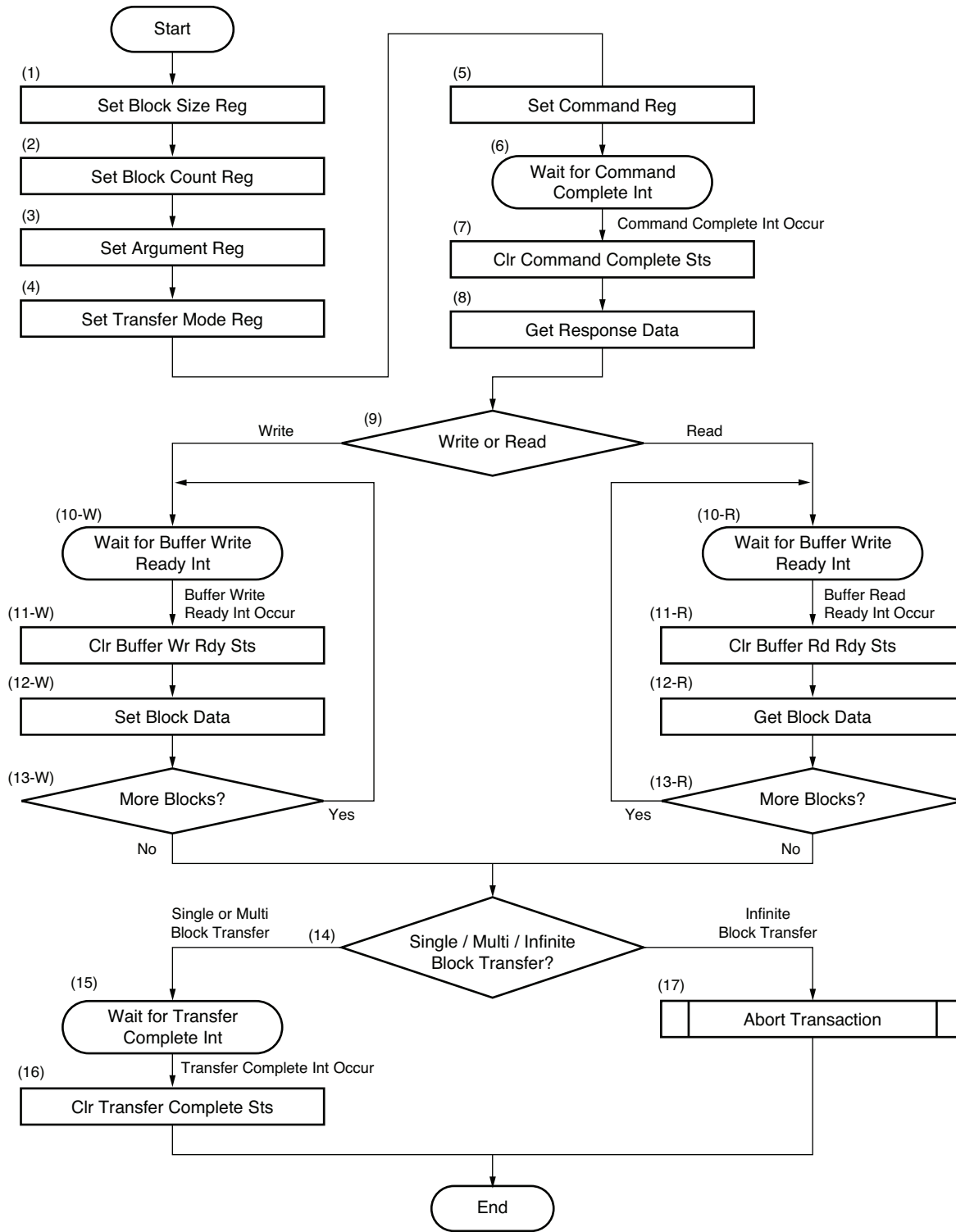

UG585_c13_03_031812

Figure 13-3: Data Transfer Using DAT Line Sequence (Without Using DMA)

The sequence for data transfers without using DMA is as follows:

1. Set the value corresponding to the executed data byte length of one block to the Block Size register.
2. Set the value corresponding to the executed data block count to the Block Count register.
3. Set the value corresponding to the issued command to the Argument register.
4. Set the value to Multi/Single Block Select and Block Count Enable. Set the value corresponding to the issued command to Data Transfer Direction, Auto CMD12 Enable, and DMA Enable.
5. Set the value corresponding to the issued command to the Command register.
Note: When writing the upper byte of the command register, the SD command is issued.
6. Wait for the command complete interrupt.
7. Write a 1 to the Command Complete bit in the Normal Interrupt Status register to clear this bit.
8. Read the Response register and get the necessary information in accordance with the issued command.
9. In the case where this sequence is for writing to a card, go to Step (10-W). In case of read from a card, go to Step (10-R).

(10-W). Wait for a buffer write ready interrupt.

- Non-DMA Write Transfer

On receiving the buffer write ready interrupt the Arm processor acts as a master and starts transferring the data via the Buffer Data Port register (FIFO_1). The transmitter starts sending the data on the SD bus when a block of data is ready in FIFO_1. While transmitting the data on the SD bus the buffer write ready interrupt is sent to the Arm processor for the second block of data. The Arm processor acts as a master and starts sending the second block of data via the buffer data port register to FIFO_2. The buffer write ready interrupt is asserted only when a FIFO is empty and available to receive a block of data.

(11-W). Write a 1 to the Buffer Write Ready bit in the Normal Interrupt Status register to clear this bit.

(12-W). Write a block of data (according to the number of bytes specified in Step (1)) to the Buffer Data Port register.

(13-W). Repeat until all blocks are sent and then go to Step (14).

- Non-DMA Read Transfer

A buffer read ready interrupt is asserted whenever a block of data is ready in one of the FIFOs. On receiving the buffer read ready interrupt, the Arm processor acts as a master and starts reading the data via the Buffer Data Port register (FIFO_1). The receiver starts reading the data from the SD bus only when a FIFO is empty and available to receive a block of data. When both of the FIFOs are full the host controller stops the data coming from the card by means of a read wait mechanism (if the card supports read wait) or through clock stopping.

(10-R). Wait for a buffer read ready interrupt

- (11-R). Write a 1 to the Buffer Read Ready bit in the Normal Interrupt Status register to clear this bit.
- (12-R). Read a block of data (according to the number of bytes specified in Step (1)) from the Buffer Data Port register.
- (13-R). Repeat until all blocks are received and then go to Step (14).
- 14. If this sequence is for a single or multiple block transfer, go to Step (15). In case of an infinite block transfer, go to Step (17).
- 10. Wait for a transfer complete interrupt.
- 11. Write a 1 to the Transfer Complete bit in the Normal Interrupt Status register to clear this bit.
- 12. Perform the sequence for abort transaction.

Note: Step (1) and Step (2) can be executed at same time. Step (4) and Step (5) can be executed at same time.

13.3.3 Using DMA

Figure 13-4 shows data transfers using DMA.

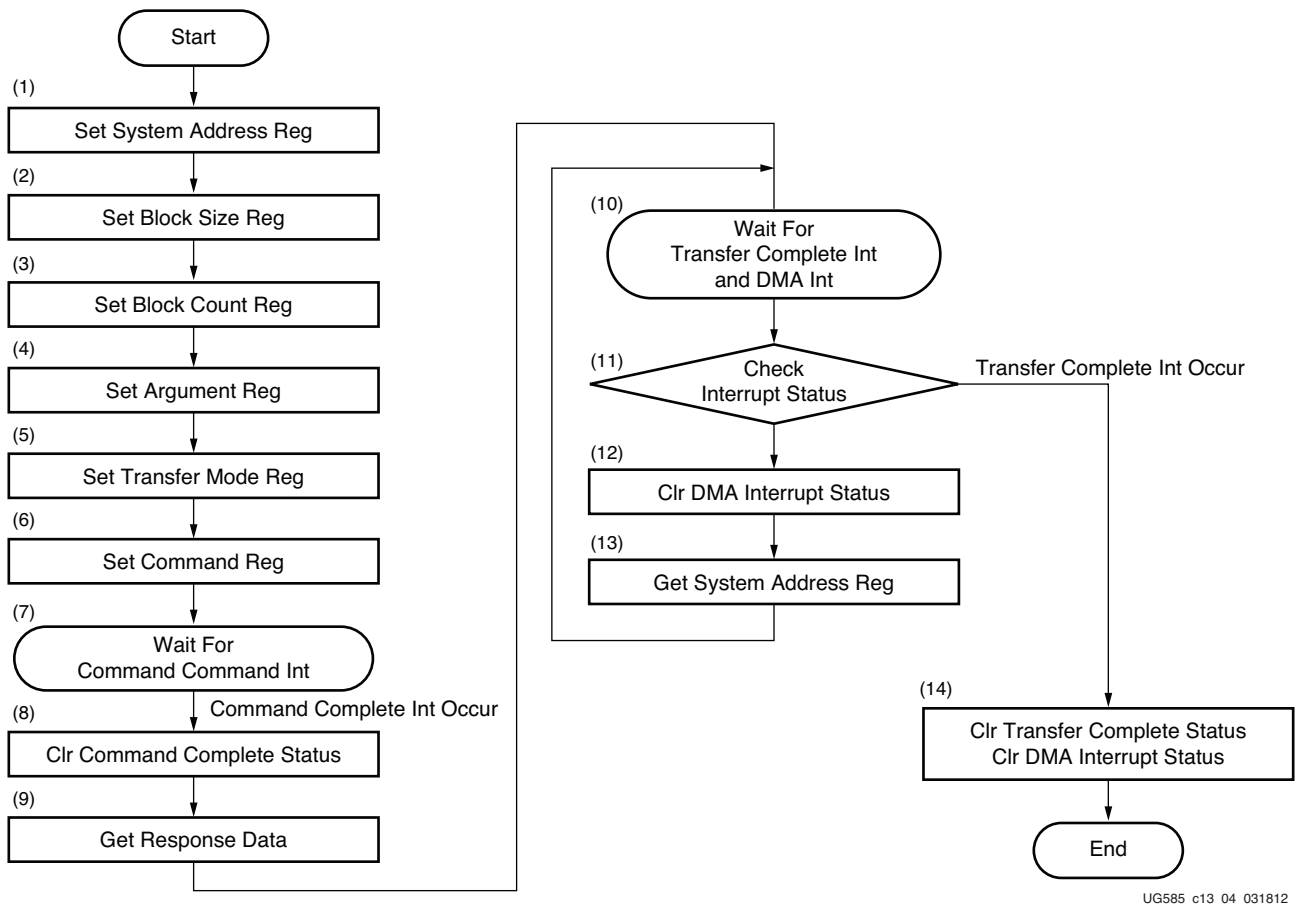

Figure 13-4: SDIO Controller Data Transfer Using DMA

Burst types such as an 8-beat incrementing burst or a 4-beat incrementing burst, or a single transfer is used to transfer or receive the data from the system memory mainly to avoid the hold of the AHB bus by the master for a longer time.

The sequence for using DMA is as follows:

1. Set the system address for DMA in the System Address register.
 2. Set the value corresponding to the executed data byte length of one block in the Block Size register.
 3. Set the value corresponding to the executed data block count in the Block Count register.
 4. Set the value corresponding to the issued command to the Argument register.
 5. Set the value to Multi/Single Block Select and Block Count Enable. Set the value corresponding to the issued command to Data Transfer Direction, Auto CMD12 Enable, and DMA Enable.
 6. Set the value corresponding to the issued command to the Command register.
- Note:** When writing to the upper byte of the Command register, the SD command is issued.
7. Wait for the command complete interrupt.
 8. Write a 1 to the Command Complete in the Normal Interrupt Status register for clearing this bit.
 9. Read the Response register and get the necessary information in accordance with the issued command.

- DMA Write Transfer

On receiving the Response End Bit from the card for the write command (data is flowing from the host to the card) the SD host controller acts as the master and requests the AHB bus. After receiving the grant the host controller starts reading a block of data from system memory and fills the first half of the FIFO. Whenever a block of data is ready the transmitter starts sending the data on the SD bus.

While transmitting the data on the SD bus the host controller requests the bus to fill the second block in the second half of the FIFO. "Ping Pong" FIFOs are used to increase the throughput. Similarly, the host controller reads a block of data from system memory whenever a FIFO is empty. This continues until all of the blocks are read from system memory. A transfer complete interrupt is set only after transferring all of the blocks of data to the card.

- DMA Read Transfer

The block of data received from the card (data is flowing from the card to the host) is stored in the first half of the FIFO. Whenever a block of data is ready the SD host controller acts as the master and request the AHB bus. After receiving the grant the host controller starts writing a block of data into system memory from the first half of the FIFO.

While transmitting data into system memory the host controller receives the second block of data and stores it in the second half of the FIFO. Similarly the host controller writes a block of data into system memory whenever data is ready. This continues until all of the blocks are transferred to system memory. A transfer complete interrupt is set only after transferring all of the blocks of data into system memory.

Note: The host controller receives a block of data from the card only when it has room to store a block of data in the FIFO. When both FIFOs are full the host controller stops the data coming from the card through a "read wait" mechanism (if the card supports read wait) or through clock stopping.

10. Wait for the transfer complete interrupt and DMA interrupt.
11. If Transfer Complete is set to 1, go to Step (14). If DMA Interrupt is set to 1 go to Step (12). Transfer Complete has a higher priority than DMA Interrupt.
12. Write a 1 to the DMA Interrupt bit in the Normal Interrupt Status register to clear this bit.
13. Set the next system address of the next data position to the System Address register and go to Step (10).
14. Write a 1 to the Transfer Complete and DMA Interrupt in the Normal Interrupt Status register to clear this bit.

Note: Step (2) and Step (3) can be executed at same time. Step (5) and Step (6) can also be executed at same time.

For example, if the host wants to transfer 4 KB of data to the card and assuming the maximum block size is 256 bytes, the host driver programs the Block Size register as 256 and Block Count register with the value 16. The AHB master and transmitter residing inside the SD2.0/SDIO2.0 host controller get the information (how much data to transfer) from these registers. Using the above information, the AHB master acts as a master and initiates a data read transaction (to read a block of data — 256 bytes from the system memory).

The following types of burst are used mainly to avoid hold of the AHB bus by the master for a longer time.

- Single transfer
- 4-beat incrementing burst
- 8-beat incrementing burst

The first block of data is received in the first half of the FIFO and the second block in the second half of the FIFO. Similarly, the remaining blocks are received in alternate FIFOs. Whenever a block of data is ready in FIFO, the transmitter starts transmitting the block of data (256 bytes) onto the SD bus. After transmitting the entire block of data to the card, the transmitter waits for a status response from the card. Transmitter sends the next block of data only when it receives a good status response from the card for the previous block of data, otherwise the transaction is aborted and the host goes for a fresh transaction.

13.3.4 Using ADMA

Figure 13-5 shows data transfers using ADMA.

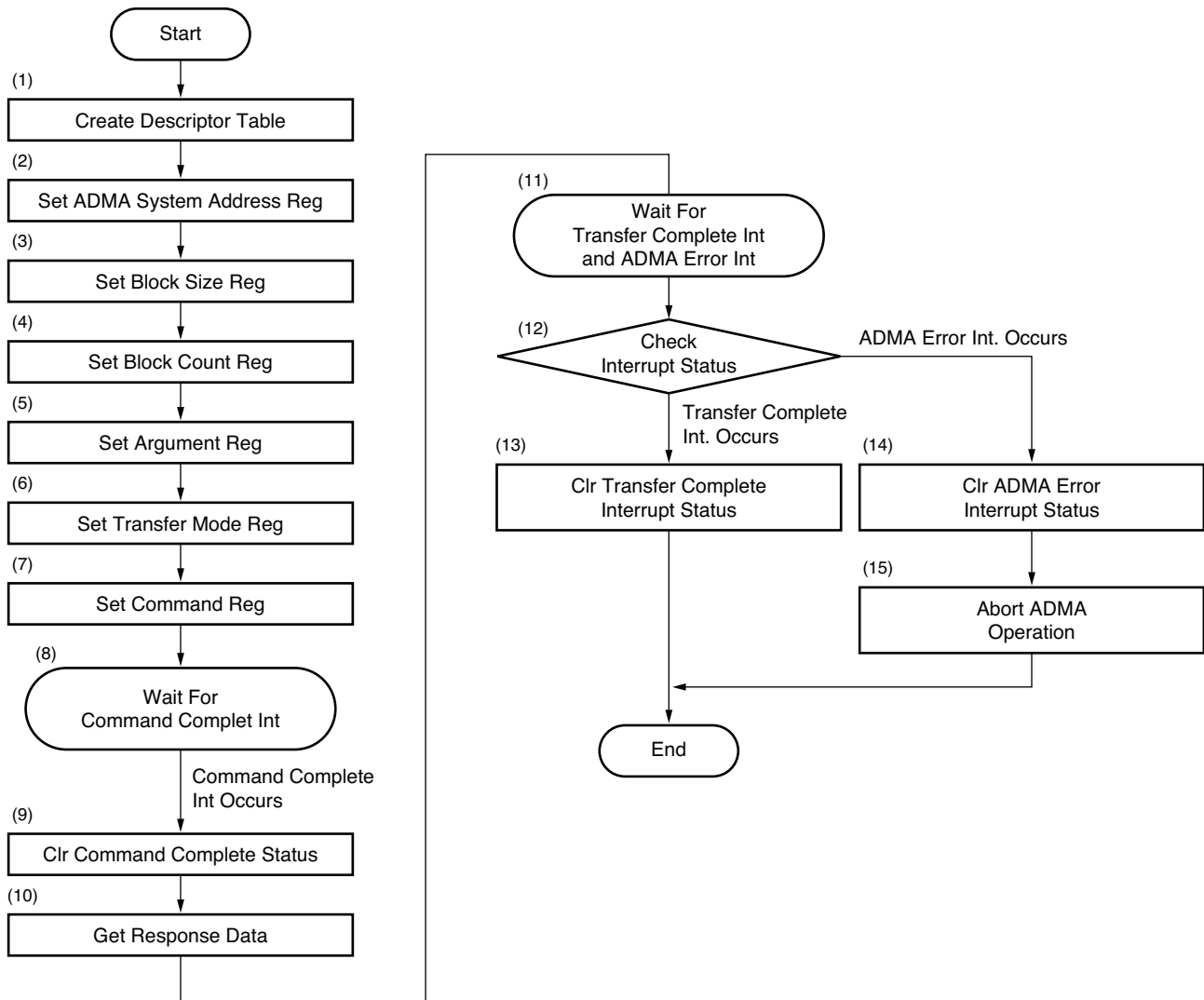

UG585_c13_05_031812

Figure 13-5: SDIO Controller Data Transfer Using ADMA

The sequence for using ADMA is as follows

1. Create a descriptor table for ADMA in system memory.
2. Set the descriptor address for ADMA in the ADMA System Address register.
3. Set the value corresponding to the executed data byte length of one block in the Block Size register.
4. Set the value corresponding to the executed data block count in the Block Count register in accordance with SDIO register map.

If the Block Count Enable bit in the Transfer Mode register is set to 1, the total data length can be designated by the Block Count register and the descriptor table. These two parameters shall indicate same data length. However, transfer length is limited by the 16-bit Block Count register. If the Block Count Enable bit in the Transfer Mode register is set to 0, the total data length is designated not by Block Count register, but the descriptor table. In this case, if the ADMA reads more data than the length programmed in the descriptor from the SD card, the operation is aborted asynchronously and the extra read data is discarded when the ADMA is completed.

5. Set the argument value to the Argument register.
6. Set the value to the Transfer Mode register. The host driver determines Multi/Single Block Select, Block Count Enable, Data Transfer Direction, Auto CMD12 Enable and DMA Enable. Multi/Single Block Select and Block Count Enable are determined according to SDIO register map.
7. Set the value to the Command register.

Note: When writing to the upper byte [3] of the Command register, the SD command is issued and DMA is started.
8. Wait for the command complete interrupt.
9. Write a 1 to the Command Complete bit in the Normal Interrupt Status register to clear this bit.
10. Read the Response register and get the necessary information from the issued command.
11. Wait for the transfer complete interrupt and ADMA error interrupt.
12. If the Transfer Complete is set to 1, go to Step (13). If the ADMA Error Interrupt is set to 1, go to Step (14).
13. Write a 1 to the Transfer Complete Status bit in the Normal Interrupt Status register to clear this bit.
14. Write a 1 to the ADMA Error Interrupt Status bit in the Error Interrupt Status register to clear this bit.
15. Abort ADMA operation. SD card operation should be stopped by issuing an abort command. If necessary, the host driver checks the ADMA Error Status register to detect why the ADMA error is generated.

Note: Step (3) and Step (4) can be executed simultaneously. Step (6) and Step (7) can also be executed simultaneously.

Note: During ADMA2 operation, the controller will not generate a DMA interrupt if the INT attribute is set along with NOP, RSVD, or LINK attribute.

13.3.5 Abort Transaction

An abort transaction is performed using CMD12 for a SD memory card and by using CMD52 for a SDIO card. There are two cases where the HD needs to do an abort transaction:

- When the HD stops infinite block transfers.
- When the HD stops transfers while a multiple block transfer is executing.

There are two ways to issue an abort command. The first is an asynchronous abort. The second is a synchronous abort. In an asynchronous abort sequence, the HD can issue an abort command at anytime unless the Command Inhibit (CMD) bit in the Present State register is set to 1. In a synchronous abort, the HD issues an abort command after the data transfer stopped via the Stop At Block Gap Request bit in the Block Gap Control register.

Synchronous Abort

The following sequence performs a synchronous abort.

1. Set the Stop At Block Gap Request bit in the Block Gap Control register to 1 to stop SD transactions.
2. Wait for a transfer complete interrupt.

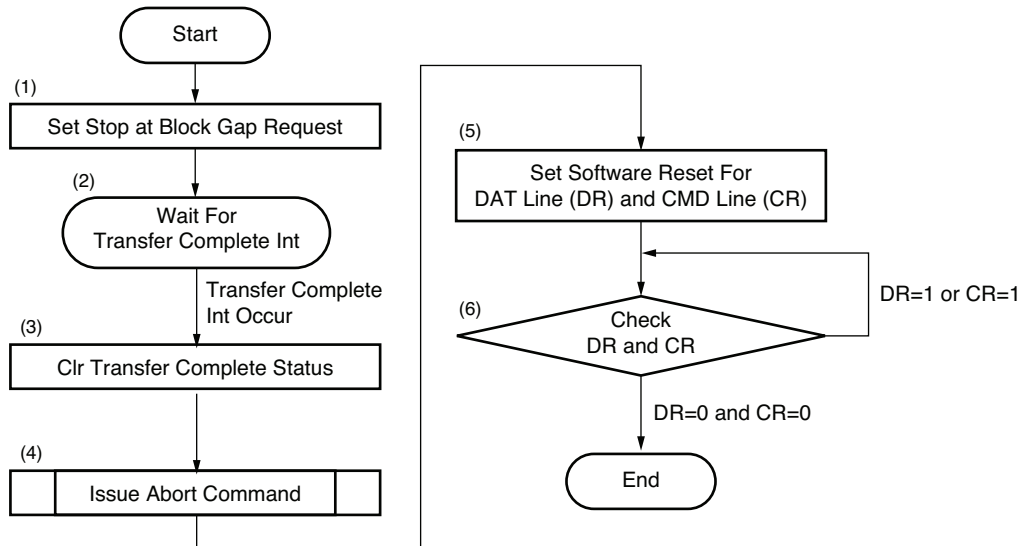

UG585_c13_06_031812

Figure 13-6: SDIO Controller Synchronous Abort Sequence

3. Set the Transfer Complete bit to 1 in the Normal Interrupt Status register to clear this bit.
4. Issue an abort command.
5. Set both the Software Reset for DAT Line and Software Reset for CMD Line bits to 1 in the Software Reset register to do a software reset.
6. Check the Software Reset for DAT Line and Software Reset for CMD Line in the Software Reset register. If both Software Reset for DAT Line and Software Reset for CMD Line are 0, go to "END". If either the Software Reset for DAT Line or the Software Reset for CMD Line is 1, repeat Step (6).

13.3.6 External Interface Usage Example

Zynq-7000 devices provide two secure digital (SD) ports that support SD and SDIO devices (see Figure 13-7).

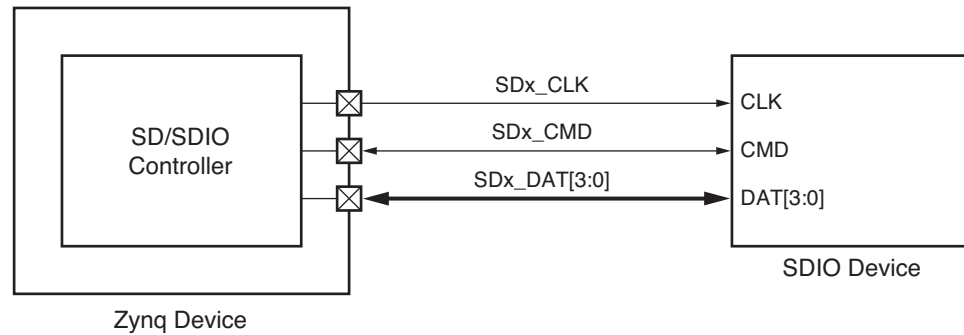

Figure 13-7: SDIO Controller Device Wiring Diagram

13.3.7 Supported Configurations

The SD/SDIO controller supports operation in several configurations:

- Secure digital (SD) memory
- Secure digital input/output (SDIO)

Some SD card slots provide two additional pins: card detect (CDn) to signal the insertion or presence of a card, and write protect (WP) to report the position of the write protect switch on the memory card. These signals must be externally pulled up. The card normally pulls CDn Low when inserted. If the WP switch is set to protect the card from writes, then the WP signal remains High. The wiring schematic is shown in Figure 13-8. If the card does not function in this manner, then an alternate method is required to signal the insertion or presence of the card. Additional board design information is located in [UG933](#), *Zynq-7000 SoC PCB Design Guide*.

Production versions of the BootROM do not look for CDn to be pulled Low; it assumes the card is installed. Xilinx drivers require that these signals are routed through the MIO and function properly to provide card state to the software. The routing is done using a `slcr.SD{1,0}_WP_CD_SEL` register.

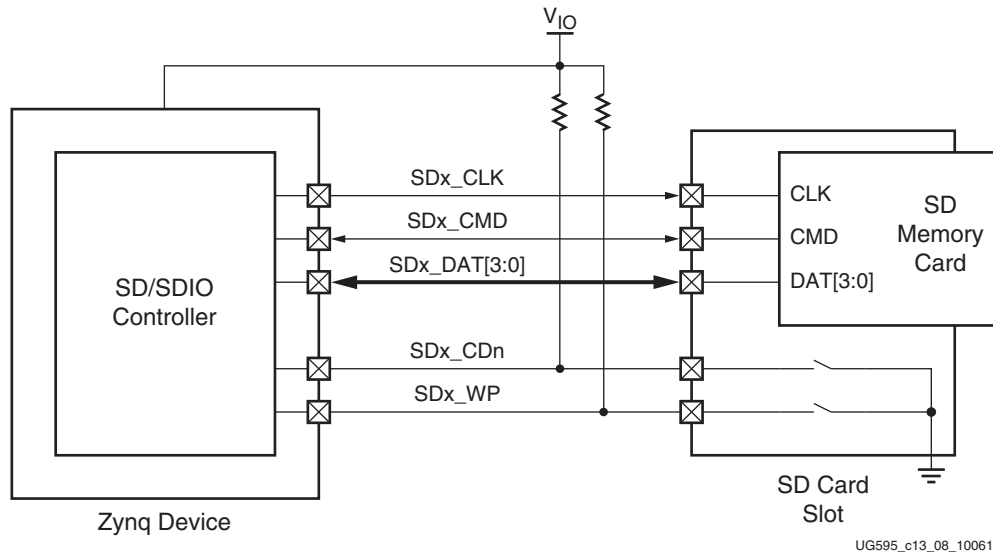

Figure 13-8: SDIO Controller SD Card Detect and Write Protect Diagram

13.3.8 Bus Voltage Translation

The SDIO power pin SDx_POW can be used to control power to the SDIO slots. Depending on the I/O voltage for the selected MIO bank and the SD/SDIO devices connected to the bus, it might be necessary to use a level translator.

13.4 SDIO Controller Media Interface Signals

The SDIO media interface signals are independently routed to the MIO pins or to a set of EMIO interface signals, see Table 13-1. The MIO pins and any restrictions based on device version are shown in the MIO table in section 2.5.4 MIO-at-a-Glance Table.

Table 13-1: SDIO Interface Signals

| SDIO Interface | Default Controller Input Value | MIO Pin | | EMIO Signal ⁽¹⁾ | |
|----------------|--------------------------------|------------|-----|----------------------------|-----|
| | | Number | I/O | Name | I/O |
| SDIO 0 Clock | 0 | 16, 28, 40 | IO | EMIOSDIO0CLKFB | I |
| | ~ | | | EMIOSDIO0CLK | O |
| SDIO 0 Command | 0 | 17, 29, 41 | IO | EMIOSDIO0CMDI | I |
| | ~ | | | EMIOSDIO0CMDO | O |
| | ~ | | | EMIOSDIO0CMDTN | O |

Table 13-1: SDIO Interface Signals (Cont'd)

| SDIO Interface | Default Controller Input Value | MIO Pin | | EMIO Signal ⁽¹⁾ | |
|----------------------|--------------------------------|------------------------|-----|----------------------------|-----|
| | | Number | I/O | Name | I/O |
| SDIO 0 Data 0 | 0 | 18, 30, 42 | IO | EMIOSDIO0DATAI0 | I |
| | ~ | | | EMIOSDIO0DATAO0 | O |
| | ~ | | | EMIOSDIO0DATATN0 | O |
| SDIO 0 Data 1 | 0 | 19, 31, 43 | IO | EMIOSDIO0DATAI1 | I |
| | ~ | | | EMIOSDIO0DATAO1 | O |
| | ~ | | | EMIOSDIO0DATATN1 | O |
| SDIO 0 Data 2 | 0 | 20, 32, 44 | IO | EMIOSDIO0DATAI2 | I |
| | ~ | | | EMIOSDIO0DATAO2 | O |
| | ~ | | | EMIOSDIO0DATATN2 | O |
| SDIO 0 Data 3 | 0 | 21, 33, 45 | IO | EMIOSDIO0DATAI3 | I |
| | ~ | | | EMIOSDIO0DATAO3 | O |
| | ~ | | | EMIOSDIO0DATATN3 | O |
| SDIO 0 Card Detect | | Any pin except 7 and 8 | I | EMIOSDIO0CDN | I |
| SDIO 0 Write Protect | | Any pin except 7 and 8 | I | EMIOSDIO0WP | I |
| SDIO 0 Power Control | ~ | Any even pin | O | EMIOSDIO0BUSPOW | O |
| SDIO 0 LED Control | ~ | ~ | ~ | EMIOSDIO0LED | O |
| SDIO 0 Bus Voltage | ~ | ~ | ~ | EMIOSDIO0BUSVOLT[2:0] | O |
| SDIO 1 Clock | 0 | 12, 24, 36, 48 | IO | EMIOSDIO1CLKFB | I |
| | ~ | | | EMIOSDIO1CLK | O |
| SDIO 1 Command | 0 | 11, 23, 35, 47 | IO | EMIOSDIO1CMDI | I |
| | ~ | | | EMIOSDIO1CMDO | O |
| | ~ | | | EMIOSDIO1CMDTN | O |
| SDIO 1 Data 0 | 0 | 10, 22, 34, 46 | IO | EMIOSDIO1DATAI0 | I |
| | ~ | | | EMIOSDIO1DATAO0 | O |
| | ~ | | | EMIOSDIO1DATATN0 | O |
| SDIO 1 Data 1 | 0 | 13, 25, 37, 49 | IO | EMIOSDIO1DATAI1 | I |
| | ~ | | | EMIOSDIO1DATAO1 | O |
| | ~ | | | EMIOSDIO1DATATN1 | O |
| SDIO 1 Data 2 | 0 | 14, 26, 38, 50 | IO | EMIOSDIO1DATAI2 | I |
| | ~ | | | EMIOSDIO1DATAO2 | O |
| | ~ | | | EMIOSDIO1DATATN2 | O |
| SDIO 1 Data 3 | 0 | 15, 27, 39, 51 | IO | EMIOSDIO1DATAI3 | I |
| | ~ | | | EMIOSDIO1DATAO3 | O |
| | ~ | | | EMIOSDIO1DATATN3 | O |

Table 13-1: SDIO Interface Signals (Cont'd)

| SDIO Interface | Default Controller Input Value | MIO Pin | | EMIO Signal ⁽¹⁾ | |
|----------------------|--------------------------------|------------------------|-----|----------------------------|-----|
| | | Number | I/O | Name | I/O |
| SDIO 1 Card Detect | | Any pin except 7 and 8 | I | EMIOSDIO1CDN | I |
| SDIO 1 Write Protect | | Any pin except 7 and 8 | I | EMIOSDIO1WP | I |
| SDIO 1 Power Control | ~ | Any odd pin | O | EMIOSDIO1BUSPOW | O |
| SDIO 1 LED Control | ~ | ~ | ~ | EMIOSDIO1LED | O |
| SDIO 1 Bus Voltage | ~ | ~ | ~ | EMIOSDIO1BUSVOLT[2:0] | O |

Notes:

1. In production silicon, the EMIO three-state control signals are inverted by the Processing_System7 wrapper.

13.4.1 SDIO EMIO Considerations

The SDIO interfaces are enabled through the MIO as well as the EMIO interface. They are mutually exclusive in that once the interface is routed through the MIO it no longer is available via the EMIO. If the designer chooses to use the EMIO interface for SDIO due to other MIO priorities, the designer should know that the maximum operating frequency for SDIO via EMIO is limited. The PL connectivity should connect the EMIO signals directly to the SelectIO pins. Additionally, it might be necessary to restrict the SDIO to operate in full or low speed modes, refer to the data sheet for frequency and timing values.

General Purpose I/O (GPIO)

14.1 Introduction

The general purpose I/O (GPIO) peripheral provides software with observation and control of up to 54 device pins via the MIO module. It also provides access to 64 inputs from the Programmable Logic (PL) and 128 outputs to the PL through the EMIO interface. The GPIO is organized into four banks of registers that group related interface signals.

Each GPIO is independently and dynamically programmed as input, output, or interrupt sensing. Software can read all GPIO values within a bank using a single load instruction, or write data to one or more GPIOs (within a range of GPIOs) using a single store instruction. The GPIO control and status registers are memory mapped at base address `0xE000_A000`.

14.1.1 Features

Key features of the GPIO peripheral are summarized as follows:

- 54 GPIO signals for device pins (routed through the MIO multiplexer)
 - Outputs are 3-state capable
- 192 GPIO signals between the PS and PL via the EMIO interface
 - 64 Inputs, 128 outputs (64 true outputs and 64 output enables)
- The function of each GPIO can be dynamically programmed on an individual or group basis
- Enable, bit or bank data write, output enable and direction controls
- Programmable interrupts on individual GPIO basis
 - Status read of raw and masked interrupt
 - Selectable sensitivity: Level-sensitive (High or Low) or edge-sensitive (positive, negative, or both)

14.1.2 Block Diagram

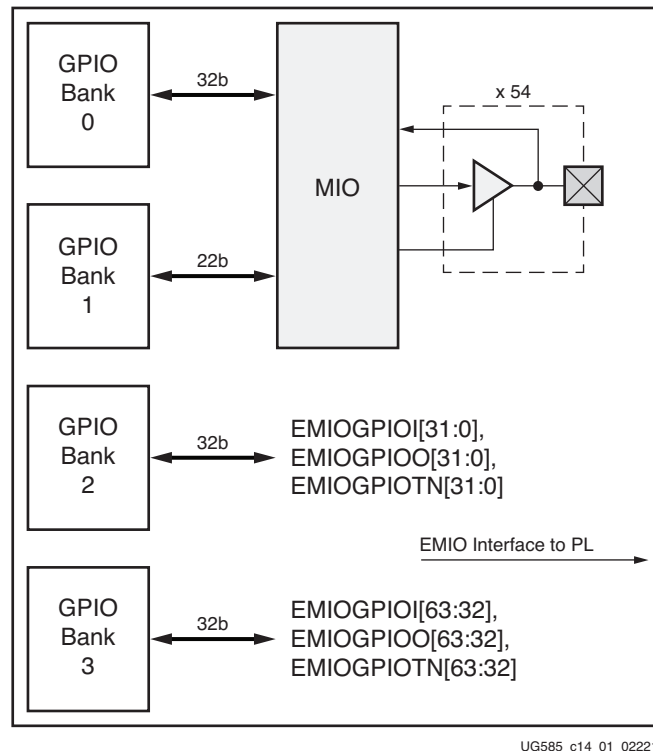

Figure 14-1: GPIO Block Diagram

As shown in Figure 14-1, the GPIO module is divided into four banks:

- Bank0: 32-bit bank controlling MIO pins[31:0]
- Bank1: 22-bit bank controlling MIO pins[53:32]
- **Note:** Bank1 is limited to 22 bits because the MIO has a total of 54 pins.
- Bank2: 32-bit bank controlling EMIO signals[31:0]
- Bank3: 32-bit bank controlling EMIO signals[63:32]

The GPIO is controlled by software through a series of memory-mapped registers. The control for each bank is the same, although there are minor differences between the MIO and EMIO banks due to their differing functionality.

14.1.3 Notices

7z007s and 7z010 CLG225 Devices

The 7z007s single core and 7z010 dual core CLG225 devices reduce the available MIO pins to 32 as shown in the MIO table in section [2.5.4 MIO-at-a-Glance Table](#). Thus, in these devices, the only GPIO pins that are available for MIO are 15:0, 39:28, 48, 49, 52, and 53. The other MIO pins are unconnected and should not be used. All EMIO signals are available.

MIO Considerations

Banks 0 and 1 of the GPIO peripheral module are routed to device pins through the MIO module. Refer to section [2.5 PS-PL MIO-EMIO Signals and Interfaces](#) for a complete description of MIO operation. Primary control of the MIO is achieved through the `slcr.MIO_PIN_xx` registers. Please note the following:

- The user must choose the proper Type of I/O using the `IO_Type`, `PULLUP`, `DisableRcvr`, and `Speed` fields according to the user's system.
- The user must select the GPIO module through the multiplexor control fields `L0_SEL`, `L1_SEL`, `L2_SEL`, and `L3_SEL`. Note that each I/O pin can be individually selected. When an MIO pin is used for an IOP device, it is not available as a GPIO.
- `TRI_ENABLE` should be set to 0. This enables the GPIO to control the 3-state mode of the I/O. If `TRI_ENABLE` is set to 1 in the MIO, then the output driver will be 3-stated regardless of GPIO settings.

14.2 Functional Description

14.2.1 GPIO Control of Device Pins

This section describes the operation of Bank0 and Bank1 (see [Figure 14-2](#)).

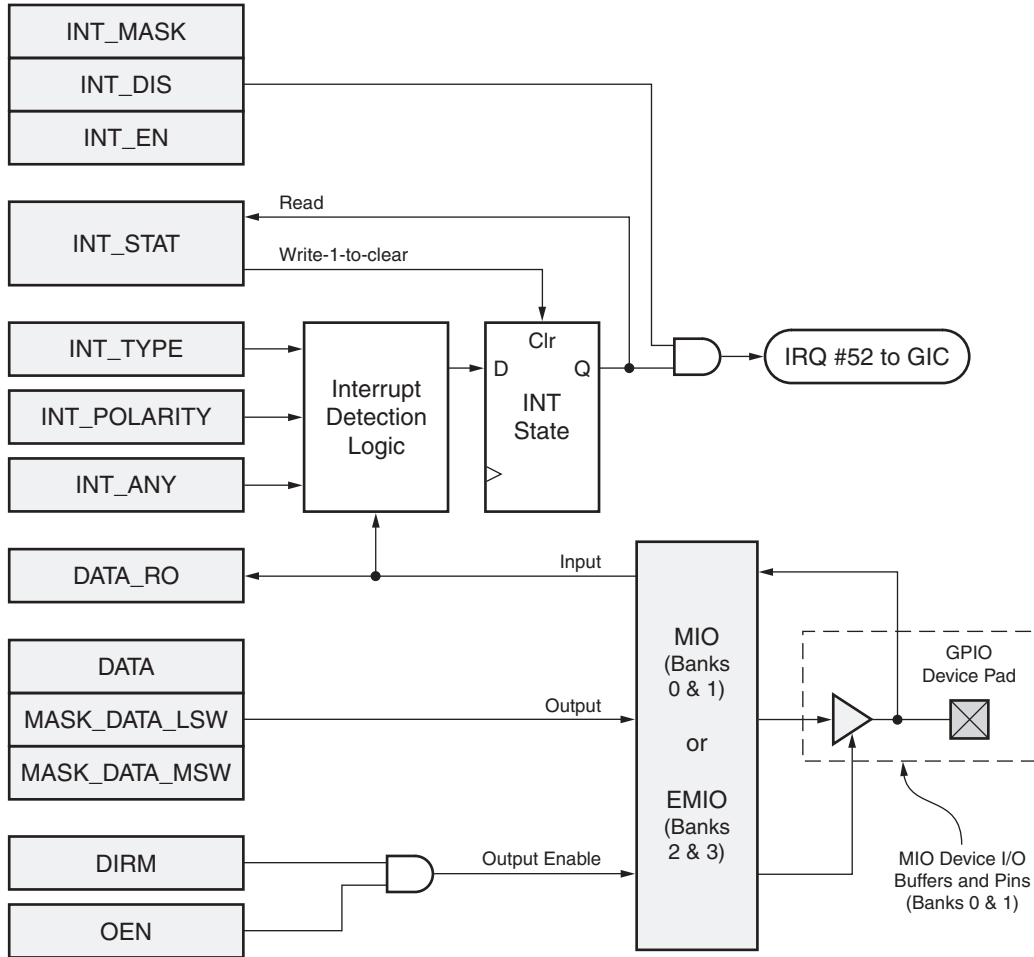

UG585_c14_02_022712

Figure 14-2: GPIO Channel

Software configures the GPIO as either an output or input. The DATA_RO register always returns the state of the GPIO pin regardless of whether the GPIO is set to input (OE signal false) or output (OE signal true). To generate an output waveform, software repeatedly writes to one or more GPIOs (usually using the MASK_DATA register).

Applications might need to switch more than one GPIO at the same time (less a small amount of inherent skew time between two I/O buffers). In this case, all of the GPIOs that need to be switched simultaneously must be from the same 16-bit half-bank (i.e., either the most-significant 16 bits or the least-significant 16 bits) of GPIOs to enable the MASK_DATA register to write to them in one store instruction.

GPIO bank control (for Bank0 and Bank1) is summarized as follows:

- **DATA_RO:** This register enables software to observe the value on the device pin. If the GPIO signal is configured as an output, then this would normally reflect the value being driven on the output. Writes to this register are ignored.

Note: If the MIO is not configured to enable this pin as a GPIO pin, then DATA_RO is unpredictable because software cannot observe values on non-GPIO pins through the GPIO registers.

- **DATA:** This register controls the value to be output when the GPIO signal is configured as an output. All 32 bits of this register are written at one time. Reading from this register returns the previous value written to either DATA or MASK_DATA_{LSW,MSW}; it does not return the current value on the device pin.
- **MASK_DATA_LSW:** This register enables more selective changes to the desired output value. Any combination of up to 16 bits can be written. Those bits that are not written are unchanged and hold their previous value. Reading from this register returns the previous value written to either DATA or MASK_DATA_{LSW,MSW}; it does not return the current value on the device pin. This register avoids the need for a read-modify-write sequence for unchanged bits.
- **MASK_DATA_MSW:** This register is the same as MASK_DATA_LSW, except it controls the upper 16 bits of the bank.
- **DIRM:** Direction Mode. This controls whether the I/O pin is acting as an input or an output. Since the input logic is always enabled, this effectively enables/disables the output driver. When DIRM[x]=0, the output driver is disabled.
- **OEN:** Output Enable. When the I/O is configured as an output, this controls whether the output is enabled or not. When the output is disabled, the pin is 3-stated. When OEN[x]=0, the output driver is disabled.

Note: If MIO TRI_ENABLE is set to 1, enabling 3-state and disabling the driver, then OEN is ignored and the output is 3-stated.

14.2.2 EMIO Signals

This section describes the operation of Bank2 and Bank3 (see [Figure 14-2](#)).

The register interface for the EMIO banks is the same as for the MIO banks described in the previous section. However, the EMIO interface is simply wires between the PS and the PL, so there are a few differences:

- The inputs are wires from the PL and are unrelated to the output values or the OEN register. They can be read from the DATA_RO register when DIRM is set to 0, making it an input.
- The output wires are not 3-state capable, so they are unaffected by OEN. The value to be output is programmed using the DATA, MASK_DATA_LSW, and MASK_DATA_MSW registers. DIRM *must* be set to 1, making it an output.
- The output enable wires are simply outputs from the PS. These are controlled by the DIRM/OEN registers as follows: EMIOGPIO_TN[x] = DIRM[x] & OEN[x]

The EMIO I/Os are not connected to the MIO I/Os in any way. The EMIO inputs cannot be connected to the MIO outputs and the MIO inputs cannot be connected to the EMIO outputs. Each bank is independent and can only be used as software observable/controllable signals.

14.2.3 Bank0, Bits[8:7] are Outputs

GPIO bits[8:7] of Bank0 correspond to package pins that are used to control the voltage mode of the I/O buffers themselves during reset. These pins are called the VMODE pin straps for the MIO banks (see section [Boot Mode Pin Settings, page 166](#)). They must be driven by the external system according to the proper voltage mode. To prevent them from being driven by other system logic, they cannot be used as general purpose inputs.

These bits can be used as general purpose outputs since the output driver is disabled at reset. The system can start using these as outputs after the voltage mode has been read during system boot.

14.2.4 Interrupt Function

The interrupt detection logic monitors the GPIO input signal. The interrupt trigger can be a positive edge, negative edge, either edge, Low-level or High-level. The trigger sensitivity is programmed using the INT_TYPE, INT_POLARITY and INT_ANY registers.

If an interrupt is detected, the GPIO's INT_STAT state is set true by the interrupt detection logic. If the INT_STAT state is enabled (unmasked), then the interrupt propagates through to a large OR function. This function combines all interrupts for all GPIOs in all four banks to one output (IRQ ID#52) to the interrupt controller. If the interrupt is disabled (masked), then the INT_STAT state is maintained until cleared, but it does not propagate to the interrupt controller unless the INT_EN is later written to disable the mask. As all GPIOs share the same interrupt, software must consider both INT_MASK and INT_STAT to determine which GPIO is causing an interrupt.

The interrupt mask state is controlled by writing a 1 to the INT_EN and INT_DIS registers. Writing a 1 to the INT_EN register disables the mask allowing an active interrupt to propagate to the interrupt controller. Writing a 1 to the INT_DIS register enables the mask. The state of the interrupt mask can be read using the INT_MASK register.

If the GPIO interrupt is edge sensitive, then the INT state is latched by the detection logic. The INT latch is cleared by writing a 1 to the INT_STAT register. For level-sensitive interrupts, the source of the interrupt input to the GPIO must be cleared in order to clear the interrupt signal. Alternatively, software can mask that input using the INT_DIS register.

The state of the interrupt signal going to the interrupt controller can be inferred by reading the INT_STAT and INT_MASK registers. This interrupt signal is asserted if INT_STAT=1 and INT_MASK=0.

GPIO bank control is summarized as follows:

- **INT_MASK:** This register is read-only and shows which bits are currently masked and which are un-masked/enabled.
- **INT_EN:** Writing a 1 to any bit of this register enables/unmasks that signal for interrupts. Reading from this register returns an unpredictable value.
- **INT_DIS:** Writing a 1 to any bit of this register masks that signal for interrupts. Reading from this register returns an unpredictable value.
- **INT_STAT:** This registers shows if an interrupt event has occurred or not. Writing a 1 to a bit in this register clears the interrupt status for that bit. Writing a 0 to a bit in this register is ignored.
- **INT_TYPE:** This register controls whether the interrupt is edge sensitive or level sensitive.
- **INT_POLARITY:** This register controls whether the interrupt is active-Low or active High (or falling-edge sensitive or rising-edge sensitive).
- **INT_ON_ANY:** If INT_TYPE is set to edge sensitive, then this register enables an interrupt event on both rising and falling edges. This register is ignored if INT_TYPE is set to level sensitive.

Table 14-1: GPIO Interrupt Trigger Settings

| Type | gpio.INT_TYPE_0 | gpio.INT_POLARITY_0 | gpio.INT_ANY_0 |
|---|-----------------|---------------------|----------------|
| Rising edge-sensitive | 1 | 1 | 0 |
| Falling edge-sensitive | 1 | 0 | 0 |
| Both rising- and falling edge-sensitive | 1 | X | 1 |
| Level sensitive, asserted High | 0 | 1 | X |
| Level sensitive, asserted Low | 0 | 0 | X |

Limitation

The GPIO controller registers require single 32-bit read/write accesses, do not use byte, halfword, or double word references.

14.3 Programming Guide

The GPIO Controller has four banks, two each for MIO and EMIO. Each GPIO pin can be programmed individually. Multiple pins can be programmed with a single write as described in section [14.2.1 GPIO Control of Device Pins](#).

14.3.1 Start-up Sequence

Main Example: Start-up Sequence

1. **Resets:** The reset options are described in section [14.4.2 Resets](#).
2. **Clocks:** The clocks are described in section [14.4.1 Clocks](#).
3. **GPIO Pin Configurations:** Configure pin as input/output is described in section [14.3.2 GPIO Pin Configurations](#).
4. **Write Data to GPIO Output pin:** Refer to example in section [14.3.3 Writing Data to GPIO Output Pins](#).
5. **Read Data from GPIO Input pin:** Refer to example in section [14.3.4 Reading Data from GPIO Input Pins](#).
6. **Set GPIO pin as wake-up event:** Refer to example in section [GPIO as Wake-up Event](#).

14.3.2 GPIO Pin Configurations

Each individual GPIO pin can be configured as input/output. However, bank0 [8:7] pins must be configured as outputs. Refer to section [14.2.3 Bank0, Bits\[8:7\] are Outputs](#) for further details.

Example: Configure MIO pin 10 as an output

1. **Set the direction as output:** Write `0x0000_0400` to the `gpio.DIRM_0` register.

2. **Set the output enable:** Write `0x0000_0400` to the `gpio.OEN_0` register.

Note: The output enable has significance only when the GPIO pin is configured as an output.

Example: Configure MIO pin 10 as an input

1. **Set the direction as input:** Write `0x0` to the `gpio.DIRM_0` register. This sets `gpio.DIRM_0[10] = 0`.

14.3.3 Writing Data to GPIO Output Pins

For GPIO pins configured as outputs, there are two options to program the desired value.

Option 1: Read, modify, and update the GPIO pin using the `gpio.DATA_0` register.

Example: Set GPIO output pin 10 using the `DATA_0` register.

1. **Read the `gpio.DATA_0` register:** Read `gpio.DATA_0` register to the `reg_val` variable.
2. **Modify the value:** Set `reg_val [10] = 1`.
3. **Write updated value to output pin:** Write `reg_val` to the `gpio.DATA_0` register.

Option 2: Use the `MASK_DATA_x_MSW/LSW` registers to update one or more GPIO pins.

Example: Set output pins 20, 25, and 30 to 1 using the `MASK_DATA_0_MSW` register.

1. **Generate the mask value for pins 20, 25, and 30:** To drive pins 20, 25 and 30, `0xBDEF` is the mask value for `gpio.MASK_DATA_0_MSW [MASK_0_MSW]`.
2. **Generate the data value for pins 20, 25, 30:** To drive 1 on pins 20, 25, and 30, `0x4210` is the data value for `gpio.MASK_DATA_0_MSW [DATA_0_MSW]`.
3. **Write the mask and data to the `MASK_DATA_x_MSW` register:** Write `0xBDEF_4210` to the `gpio.MASK_DATA_0_MSW` register.

14.3.4 Reading Data from GPIO Input Pins

For GPIO pins configured as inputs, there are two options to monitor the input.

Option 1: Use the `gpio.DATA_RO_x` register of each bank.

Example: Read the state of all GPIO input pins in bank 0 using the `DATA_RO_0` register.

1. **Read Input Bank 0:** Read the `gpio.DATA_0` register.

Option 2: Use interrupt logic on input pins (refer to section [14.2.4 Interrupt Function](#)).

Example: Configure MIO pin 12 to be triggered as rising edge.

1. **Set the trigger as a rising edge:** Write 1 to `gpio.INT_TYPE_0 [12]`. Write 1 to `gpio.INT_POLARITY_0 [12]`. Write 0 to `gpio.INT_ANY_0 [12]`.
2. **Enable interrupt:** Write 1 to `gpio.INT_EN_0 [12]`.
3. **Status of Input pin:** `gpio.INT_STAT_0 [12] = 1` implies that an interrupt event occurred.

4. **Disable interrupt:** Write 1 to gpio.INT_DIS_0 [12].

14.3.5 GPIO as Wake-up Event

The GPIO can be configured as a wake-up device.



IMPORTANT: *The GIC must be set up correctly.*

1. Enable the GPIO interrupt in the GIC.
2. Enable the GPIO interrupt for the wanted pin(s) using the gpio.INT_EN_{0..3} register. Set 1 to gpio.INT_EN_0[10] to enable the GPIO10 interrupt.
3. Do not turn off any GPIO related clocks.

14.3.6 Register Overview

An overview of the GPIO registers is shown in [Table 14-2](#) (also refer to section [14.2.1 GPIO Control of Device Pins](#)). Details of registers are provided in [Appendix B, Register Details](#).

Table 14-2: GPIO Register Overview

| Function | Register Name | Overview | Type |
|----------------------------|--------------------------------|--------------------------------|-------|
| Data Reads and Data Writes | gpio.MASK_DATA_{3:0}_{MSW,LSW} | Bit masked data output writes. | Mixed |
| | gpio.DATA_{3:0} | 32-bit data output write | R/W |
| | gpio.DATA_{3:0}_RO | 32-bit data read of inputs | RO |
| I/O Buffer Control | gpio.DIRM_{3:0} | Direction | R/W |
| | gpio.OEN_{3:0} | Output Enable | R/W |
| Interrupt Controls | gpio.INT_MASK_{3:0} | Interrupt Mask | RO |
| | gpio.INT_EN_{3:0} | Interrupt Enable | WO |
| | gpio.INT_DIS_{3:0} | Interrupt Disable | WO |
| | gpio.INT_STAT_{3:0} | Interrupt Status | WTC |
| | gpio.INT_TYPE_{3:0} | Interrupt Type | RW |
| | gpio.INT_POLARITY_{3:0} | Interrupt Polarity | RW |
| | gpio.INT_ANY_{3:0} | Interrupt Any | RW |

14.4 System Functions

The controller clocks and resets are described in this section. All of the interrupts generated in the GPIO controller are routed to IRQ 52. The GPIO I/O signals are routed to either the MIO or EMIO.

14.4.1 Clocks

The controller is clocked by the CPU_1x clock from the APB interface. All outputs and input sampling is done using the CPU_1x clock.

For power management, clock gating can be employed on the GPIO controller clock using `slcr.APER_CLK_CTRL[GPIO_CPU_1XCLKACT]`.

14.4.2 Resets

The controller is reset by the `slcr.GPIO_RST_CTRL [GPIO_CPU1X_RST]` bit. Refer to [Chapter 26, Reset System](#), for more information. This reset only affects the bus interface, not the controller logic itself.

14.4.3 Interrupts

The controller interrupts are explained in section [14.2.4 Interrupt Function](#). The controller asserts IRQ # 52 to the GIC. A programming example is described in section [14.3.4 Reading Data from GPIO Input Pins](#).

14.5 I/O Interface

14.5.1 MIO Programming

Bank 0 and Bank 1 pins are routed through the MIO. These pins can be configured as GPIO using the `slcr.MIO_PIN_XX` register.

Example: Configure MIO pin 6 as a GPIO signal

1. Select MIO pin as GPIO: Set `L0_SEL, L1_SEL, L2_SEL, L3_SEL = 0`.
2. Set `TRI_ENABLE = 0`.
3. LVCMOS18 (refer to the register definition for other voltage options).
4. Slow CMOS edge.
5. Enable internal pull-up resistor.
6. Disable HSTL receiver.

Note: If `TRI_ENABLE=1`, then the output is 3-stated regardless of any GPIO settings. If `TRI_ENABLE=0`, then 3-state is controlled by the `gpio.OEN_x` register.

USB Host, Device, and OTG Controller

15.1 Introduction

The USB controller is capable of fulfilling a wide range of applications for USB 2.0 implementations as a host, a device, or On-the-Go. Two identical controllers are in the Zynq-7000 device. Each controller is configured and controlled independently. The USB controller I/O uses the ULPI protocol to connect external ULPI PHY via the MIO pins. The ULPI interface provides an 8-bit parallel SDR data path from the controller's internal UTMI-like bus to the PHY. The ULPI interface minimizes device pin count and is controlled by a 60 MHz clock output from the PHY.

USB is a cable bus that supports data exchange between a host device and a wide range of computer peripherals. The attached peripherals share USB bandwidth through a host-scheduled, token-based protocol. The bus allows peripherals to be attached, configured, used, and detached while the host and other peripherals remain operational.

The USB controller in USB 2.0 Host compatible with the EHCI specification with some enhancements and minor deviations. The OTG operating mode software switches the controller between Idle and either Device or Host mode as needed by the application using the Host Negotiation Protocol (HNP) and Session Request Protocol (SRP).

The controller is designed to make efficient use of the system resources in an SoC design. The DMA engine is responsible for moving USB transaction data between the Rx/Tx FIFOs and system memory. The FIFOs are used to buffer the high-speed USB data rates with periodic delays associated with the PS Interconnect data transfers.

The EHCI-compatible host controller is a schedule driven environment for data transfers of periodic (interrupt and isochronous) and asynchronous (control and bulk) types. Device mode includes a simple pair of descriptors to respond to USB data transfers in a timely manner between the software and USB.

The transfer descriptors of the host schedules and device endpoints control the DMA engine to move data between the 32-bit AHB master system bus interface and the Rx and Tx data FIFOs that respond in real-time to the USB.

The controller makes strategic use of software for tasks that do not require time-critical responses. This approach reduces the amount of hardware logic. At the same time, the controller includes hardware assistance logic to enable the controller to respond quickly to USB events and simplify the software.

15.1.1 Features

The USB controller has the following key features:

- USB 2.0 High Speed Host controller (480 Mb/s).
 - Intel® EHCI software programming model.
- USB 2.0 HS and FS Device controller.
 - Up to 12 Endpoint: Control Endpoint plus 11 configurable Endpoints
- USB 1.1 legacy FS/LS.
 - Embedded Transaction Translator to support FS/LS in Host mode.
- On-the-Go, OTG 1.3 supplement.
 - Host Negotiation Protocol (HNP).
 - Session Request Protocol (SRP).
- All USB Transaction types
 - Control, Bulk, Interrupt, Isochronous
- Local DMA Engine.
 - AHB Bus Master.
 - Transfers data between system memory and controller FIFOs.
 - Processes transfer descriptors for Device Endpoints and Host Schedules.
- Protocol Engine
 - Interprets USB packets
 - Responds in real-time based on controller status
- Port/Transceiver Controller
 - 8-bit parallel data pass-thru bus
- ULPI Link Wrapper
 - Translates Rx and Tx transfers between ULPI I/O interface and a UTMI-like interface.
 - Bridge between the protocol engine and the ULPI interface.
 - Rx and Tx commands
- ULPI I/O interface
 - 8-bit SDR data plus clock, direction, next, stop signals.
 - 12 ULPI PHY signals via MIO pins.
 - Clocked by PHY in Clock-out mode.
 - Viewport access to ULPI PHY registers
- Host port indicator, power select and power fail indicator signals.
 - 4 signals per controller via EMIO.

15.1.2 Operating Modes

The USB controller can operate in the modes shown in [Figure 15-1](#).

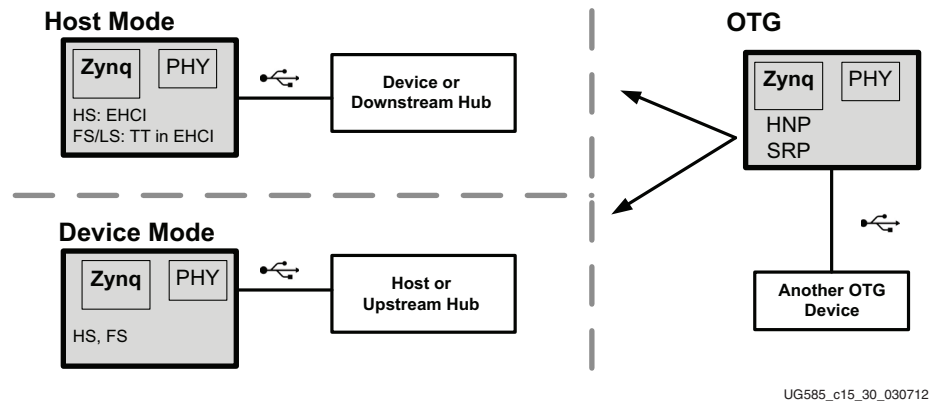

Figure 15-1: USB Controller Operating Modes

Host mode. In host mode, the software includes driver-layer programming to discover and enumerate the bus, manage PHY operations, and setup the periodic and asynchronous schedules of transfer descriptors.

- EHCI software model except as described in section [15.11 EHCI Implementation](#).

Device mode. In device mode, the controller responds to host commands. Software can include driver-layer programming to respond, as a single- or multi-function device, to the upstream commands.

On-the-Go. The OTG software switches between Host and Device modes based on the Host Negotiated Protocol (HNP) and the Session Request Protocol (SRP). Once the controller is in device or host mode, it has all the functionality of the selected mode.

15.1.3 Hardware System Viewpoint

The USB controllers are integrated into the PS IOP to bridge between the PS interconnect and an external ULPI PHY. The controller's registers are memory mapped and the local DMA engine initiates reads and writes to system memory. The ULPI signals flow through the MIO. There are sideband signals (port indicators and power controls) that flow through the EMIO interface where they are normally routed to PL SelectIO pins. The system-level viewpoint is shown in [Figure 15-2](#).

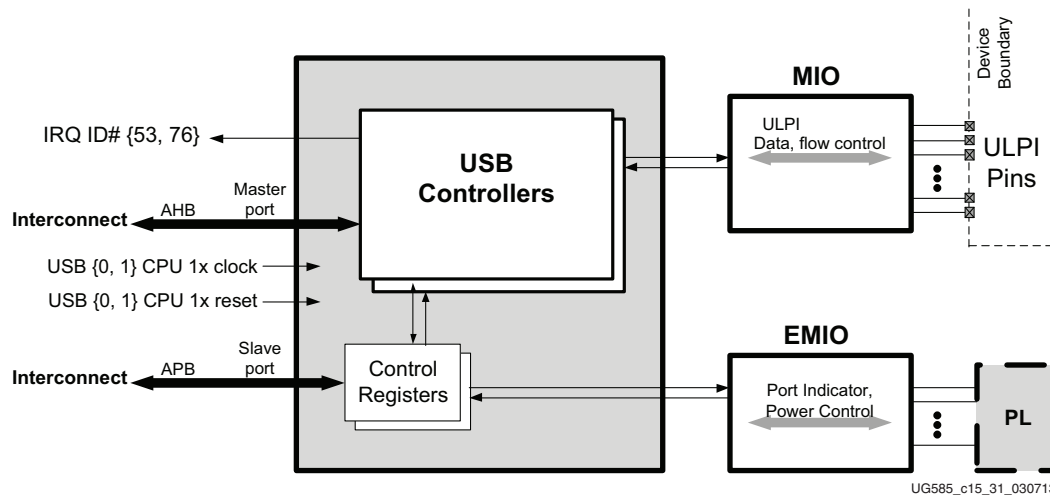

Figure 15-2: USB Hardware System Block Diagram

The two independent USB controllers have individual control and status registers. Each ULPI interface is independently enabled through the MIO. There are separate port indicator and power signals for each controller that are routed through the EMIO. The system functions are further described in section [15.15 System Functions](#).

System Interfaces

Each controller is an AHB bus master to the PS interconnect for DMA transfers. The control and status registers are accessed via the controller's APB slave interface. Each controller has its own reset input from the PS reset module and interrupt output to the interrupt controller, GIC. There is a ULPI clock input for each controller and a CPU_1x clock for the AMBA AHB and APB interfaces. Details are in section [15.15 System Functions](#).

ULPI I/O signals

The I/O signals are described in section [15.16 I/O Interfaces](#). The MIO pin muxing scheme is described, in general terms, in section [2.5 PS-PL MIO-EMIO Signals and Interfaces](#).

I/O Wiring

The ULPI interface on the MIO pins is an 8-bit SDR data bus that is augmented with port indicators and power control signals routed through the EMIO interface to the PL. The PS GPIO module, [Chapter 14, General Purpose I/O \(GPIO\)](#), can provide a PHY reset signal to the PHY.

An I/O wiring diagram is shown in [Figure 15-19 USB I/O Signal and PHY Wiring Diagram, page 482](#). Here is a summary of the I/O signals:

- **ULPI via MIO.** The controller interfaces to the external ULPI PHY via 12 MIO pins: 8 data I/Os, direction input, control input, clock input and a stop output.
- **GPIO.** A PS GPIO signal can be used to reset the external PHY.

Note: The ULPI PHY reset signal is not required for all applications.

- **Port Indicator and Power Pins via EMIO.** The USB port indicator outputs, power select output, and power fault input signals are routed through the EMIO to the SelectIO pins in the PL and external board logic.

15.1.4 Controller Block Diagram

The controller interfaces to the PS system memory on one side and an external ULPI PHY device on the USB side. A block diagram is shown in [Figure 15-3](#). A detailed functional block is shown in section [15.1.9 Notices](#).

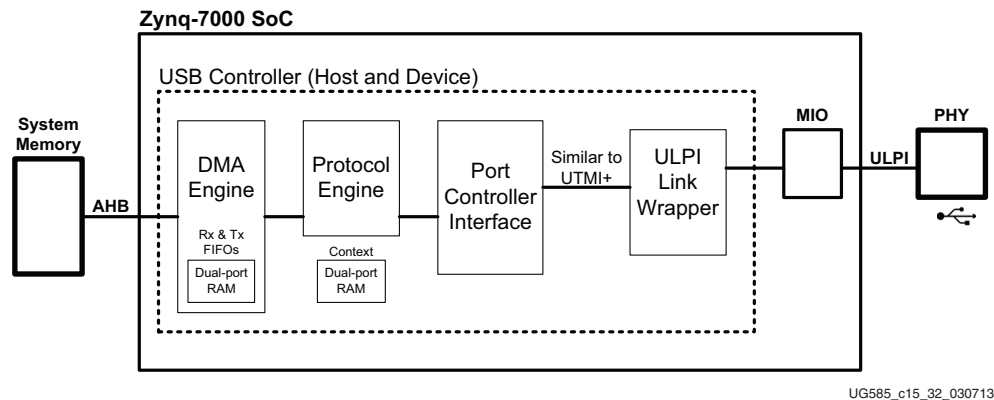

Figure 15-3: USB Controller Block Diagram

System Memory

The PS system memory is accessible to the DMA engine that holds transfer descriptors and data buffers. The system memory can be DDR, OCM and memory that is mapped in the PL. The system memory map is shown in section [4.1 Address Map](#). In this table, the USB controller is one of the “Other Bus Masters,” refer to the table footnotes.

DMA, Protocol Engines, Context and FIFOs

The DMA engine works with the Protocol engine to process endpoints, periodic elements, queue heads, and other transfer descriptors. Software writes these data structures into the system memory. The DMA engine fetches these data structures and copies them into the controller’s local dual-ported RAM (DPRAM). The controller reads and writes the data structures in the DPRAM as the data structures are processed. The descriptors are written back to memory by the DMA engine when a transfer is complete.

In addition to the context information of the data structures, the dual-port RAM is also used by the controller to implement Rx and Tx data FIFOs. These FIFOs decouple the system processor memory bus transfers from the real-time requirements of the USB.

The use of the FIFOs differs between host and device mode operation. In Host mode, a single data channel is maintained in each direction through the dual-port RAM. In Device mode, Rx and Tx data FIFO channels are maintained for each of the active device endpoints and these FIFO channels can operate simultaneously and asynchronously.

Port Transceiver Controller

The port transceiver controller provides suspend/resume and, for device mode, chirp control functions. The port transceiver controller is fairly simple because the 8-bit data bus of the protocol engine is passed-through to the 8-bit ULPI and the entire back-end of the USB controller works synchronously to the 60 MHz USB clock from the PHY.

ULPI Link Wrapper

The protocol engine includes an internal bus that is similar to UTMI+. The ULPI wrapper provides a bridge between this bus similar to UTMI+ and the ULPI interface. This is transparent to the user. The ULPI Link wrapper passes-through packet data and interprets Rx commands as well as send Tx commands.

ULPI Rx/Tx Commands

The ULPI Rx commands are initiated by the PHY to set status bits to give software visibility to PHY events. The commands set controller status bits. The Tx commands are initiated by register writes by software to control PHY functions. These commands are defined by the ULPI specification.

ULPI PHY Viewport

The ULPI viewport provides a mechanism for software to read and write PHY registers with explicit control of the address and data using the `usb.VIEWPORT` register. An interrupt is generated when a transaction is complete, including when the requested read data is available.

Programmable Timers

There are two independent general-purpose timers that can be used to generate a timeout or to measure time related activities. The programmable timers should not be confused with the controller's interval timers which are used by the controller to generate frame and microframe intervals and to generate strobes for the host controller scheduler. The programmable timers are described in section [15.2.6 General Purpose Timers](#).

Software Programming Interface

In addition to maintaining data and buffer structures in system memory, the software reads and writes the control and status registers. The CPU environment that executes the software is described in [Chapter 15, USB Host, Device, and OTG Controller](#). The controller can generate interrupts cause by the DMA and Protocol engine activities, the PHY, and other controller functions. The interrupts are summarized in [Table 15-2 USB Interrupt and Status Register Bits](#).

The system will include either a Host Controller Driver (HCD) or a Device Controller Driver (DCD). There may be additional of software to support the OTG functions.

Control and Status Registers

The control and status registers include constants, configuration and operational/status for EHCI compatibility (Host mode) and non-EHCI functions (Device, OTG and enhanced Host mode). The registers are summarized in section [15.3.4 Register Overview](#).

Clocks

The ULPI interface and Protocol engine are clocked by the 60 MHz input on the ULPI interface (PHY clock output). The AHB interface is clocked by the CPU_1x clock. The clock domain crossing between the CPU_1x clock and the 60 MHz ULPI PHY clock for the Protocol engine is at the dual-port RAM.

Resets

There are several different types of resets associated with the USB controller, these are further discussed in section [15.15.2 Reset Types](#).

- Controller Resets
 - PS Reset System (full controller reset),
 - usb.USBCMD [RST] bit (partial controller reset useful for OTG).
- ULPI PHY reset (output from PS GPIO).
- USB Bus Resets
 - Auto-Reset feature in OTG mode.
 - USB reset control transfer.

15.1.5 Configuration, Control and Status

Software manages the controller itself (configuration and control) and a consistent set of data structures and memory buffers for USB transactions. There are two data structure models (host and data) and three controller modes (host, device, and OTG). OTG uses either the host or device mode.

The controller registers are outlined in [Table 15-1 USB Controller Register Overview](#).

15.1.6 Data Structures

The controller processes descriptors to facilitate FS/LS and HS USB operations. Device and host modes use descriptors in very different ways. The models are illustrated in [Figure 15-4](#).

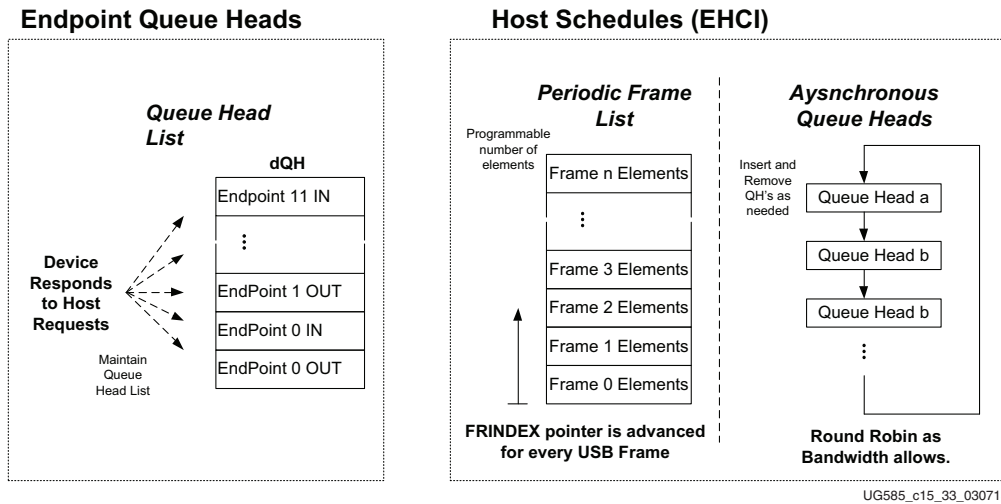

Figure 15-4: USB Endpoint Descriptors (device mode) and Schedules (host mode)

Device Mode

As requested by the host, the Device Controller Driver (DCD) sets up descriptors for endpoints and manages the real-time needs of the endpoints. The high-speed data transfers between memory and ULPI are managed by the controller using queue heads and transfer descriptors. The results of each transfer is reviewed by DCD to take appropriate action.

Device Endpoints. The device controller includes a simple descriptor model to enable the controller to quickly respond to host requests. Each of the 12 endpoints has two device Queue Heads (dQH); one for IN and the other for OUT transfer types. There are a total of 24 device dQH's. An endpoint data transfer is defined with one dQH and one or more linked list of device Transfer Descriptors (dTD). An example is shown in [Figure 15-13](#).

Host Mode

Host Schedules. The Host Controller Driver (HCD) maintains two types of transaction schedules to generate USB traffic: periodic (isochronous/interrupt) and asynchronous (bulk/control).

- The Periodic schedule is a list of high to low priority-order periodic transfers. An element in the periodic frame list is executed at the start of every frame (SOF). The list includes elements that indicate when to execute (periodic interval) and what to execute. An example is shown in [Figure 15-15](#).
- The asynchronous schedule is a circular loop of Queue Heads that point to transfer descriptors that are processed in a round-robin priority. Within each microframe, the asynchronous schedule is executed after the periodic schedule is finished. An example is shown in [Figure 15-16](#).

Link-list Concept

The host and device controllers use link-list descriptors to manage transfers to and from memory buffers. The concept is shown in [Figure 15-5](#). The first Transfer Descriptors (TD) is pointed to by a

Queue Head (QH). Each dTD can point to another dTD (using next dTD pointer) or terminate the linked list by setting its (T) bit = 1.

The controller maintains a local, working copy of the dQH that it overlays with the one or more dTDs as the transaction request is processed. After each dTD transfer is complete, the dTD overlay is written back to the system memory with transfer results (status). While a transfer is in progress, the overlay area of the dQH in controller memory is used as a staging area for the dTDs.

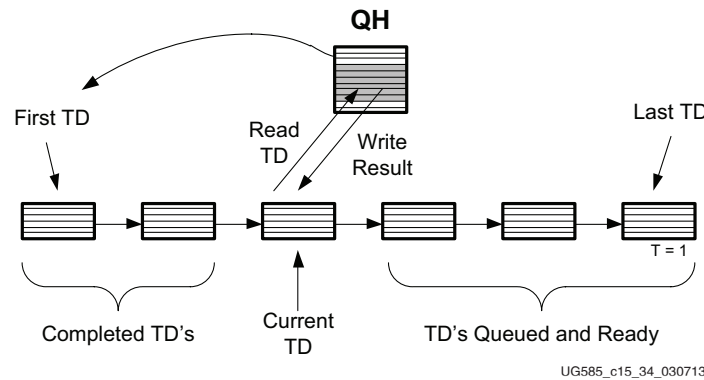

Figure 15-5: USB Controller Link-list Concept

15.1.7 Implementation Summary

There are EHCI enhancements to support the embedded Transaction Translator and hardware assistance features to support OTG. Here is a summary of special features, enhancements, deviations and unsupported features.

- EHCI Enhancements and Deviations, section [15.11 EHCI Implementation](#).
- Hardware Assistance Features for OTG, section [15.14.1 Hardware Assistance Features](#).
- Embedded Transaction Translator (no separate companion controller hardware), section [15.11.2 Embedded Transaction Translator](#).
- The AHB interface is a master-only and used by the DMA controller (no PCI registers).
- The ULPI Carkit feature is not supported.

15.1.8 Documentation

Scope of TRM

The Zynq-7000 Technical Reference Manual (TRM) describes hardware functionality and register-level software programming for Host controller mode drivers (HCD) and Device controller mode drivers (DCD). Guidance for the upper software layers, including device classes and applications, are beyond the scope of the TRM.

Documents and Specifications

The reader should be familiar of USB technology and access to the following documents. These documents are mentioned in the text and are listed in [Third-Party IP and Standards Documents in Appendix A](#).

Zynq-7000 SoC Documents

- **TRM** for all Zynq-7000 series; **UG585**. Architecture and register-level programming.
- **Data Sheet** for 7z010, 7z015, and 7z020 dual core and 7z007s, 7z012s, and 7z014s single core devices; **DS187**. Electrical specifications.
- **Data Sheet** for 7z030, 7z035, 7z045, and 7z100 devices; **DS191**. Electrical specifications.
- **Errata Sheets** for all devices; **ENxxx** (multiple). Related AR list, [AR47916](#).

7-Series FPGA Documents

- Refer to the list in [A.3.2 PL Documents – Device and Boards](#).

USB Specifications

- USB 2.0 Specification
- UTMI+ Low Pin Interface (ULPI) Specification
- Enhanced Host Controller Interface (EHCI) Specification for Universal Serial Bus

Chapter Nomenclature

- Refer to the USB 2.0 Specification, Chapter 2 Terms and Abbreviations.
- Xilinx Corporate glossary includes general terms.
- Chapter-specific terms:
 - DCD means device controller driver. This is the device driver software used in device mode.
 - HCD means host controller driver. This is the device driver software used in host mode.
 - The term Frame applies to FS/LS mode. Microframe applies to HS mode. (Micro)frame applies to FS/LS and HS modes.
 - In the USB Controller chapter, DWord means 32 bits. In the rest of the PS, a word is defined to mean 32 bits.
 - There are two dual-purpose registers (for host and device mode) listed in [Table 15-1](#). The `usb.ASYNCLISTADDR_ENDPOINTLISTADDR` register is referred to as `usb.ASYNCLISTADDR_` when discussing Host mode and `usb._ENDPOINTLISTADDR` when discussing Device mode. The `usb.PERIODICLISTBASE_DEVICEADDR` register is similar.

15.1.9 Notices

7z007s and 7z010 CLG225 Devices

The 7z007s single core and 7z010 dual core CLG225 devices support 32 MIO pins as shown in the MIO table in section [MIO-at-a-Glance Table in Chapter 2](#). Only one USB interface is available in these CLG225 devices. If USB and GigE are required, the GigE I/O signals must interface through the EMIO.

15.1.10 Chapter Overview

Functional Descriptions and Programming Guides

The USB controller chapter includes multiple sections of introductions, functional descriptions and programming guides. The functional descriptions explain controller functionality and includes register programming information that is related to hardware functions.

- Content for All Modes
 - [15.1 Introduction](#)
 - [15.2 Functional Description](#)
 - [15.3 Programming Overview and Reference](#)
 - [15.15 System Functions](#)
 - [15.16 I/O Interfaces](#)
- Device Operating Mode
 - [15.4 Device Mode Control](#)
 - [15.5 Device Endpoint Data Structures](#)
 - [15.6 Device Endpoint Packet Operational Model](#)
 - [15.7 Device Endpoint Descriptor Reference](#)
 - [15.8 Programming Guide for Device Controller](#)
 - [15.9 Programming Guide for Device Endpoint Data Structures](#)
- Host Operating Mode
 - [15.10 Host Mode Data Structures](#)
 - [15.11 EHCI Implementation](#)
 - [15.12 Host Data Structures Reference](#)
 - [15.13 Programming Guide for Host Controller](#)
- OTG Operating Mode
 - [15.14 OTG Description and Reference](#)

15.2 Functional Description

This section generally applies to both device and host modes.

15.2.1 Controller Flow Diagram

The controller flow diagram in Figure 15-6 shows the USB data transfer flows, the descriptor flows, and the interface to software.

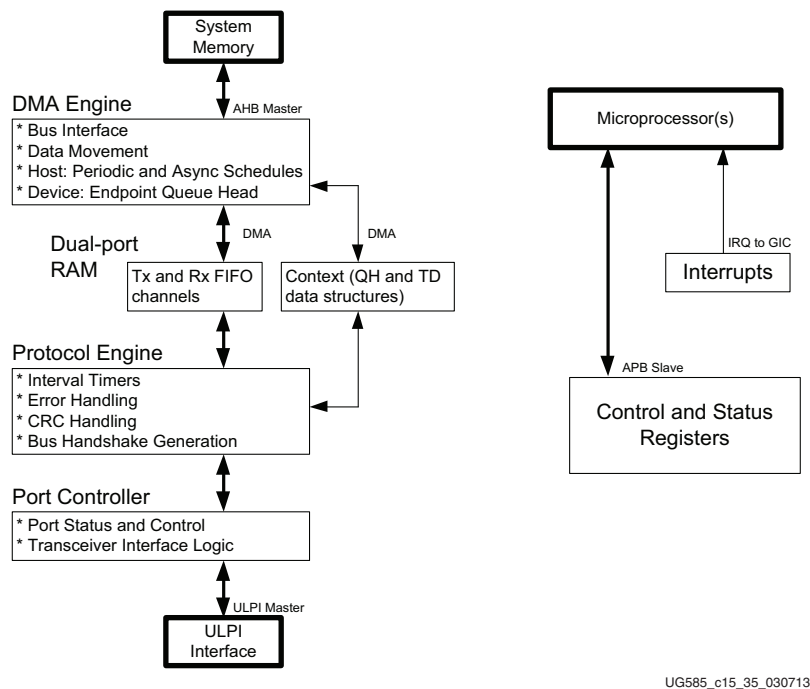

UG585_c15_35_030713

Figure 15-6: USB Controller Flow Diagram

15.2.2 DMA Engine

Data Transfers

In host mode, the data structures are defined by the EHCI specification and represent queues of periodic and asynchronous transfers to be performed by the host controller including the split transaction requests that allow the controller to direct packets to FS/LS devices that are downstream of an external HS hub or root hub. Host mode uses the queue head (QH), queue element transfer descriptor (qTD), isochronous transfer descriptor (iTd), split transaction isochronous transfer descriptor (siTD) and the periodic frame span transversal node (FSTN) data structures.

In device mode, the data structures are simpler and consist of device queue heads (dQH) and device transfer descriptors (dTd) that are used in a linked-list fashion.

The DMA engine is a 32-bit bus master on the AHB interface to access the PS system interconnect.

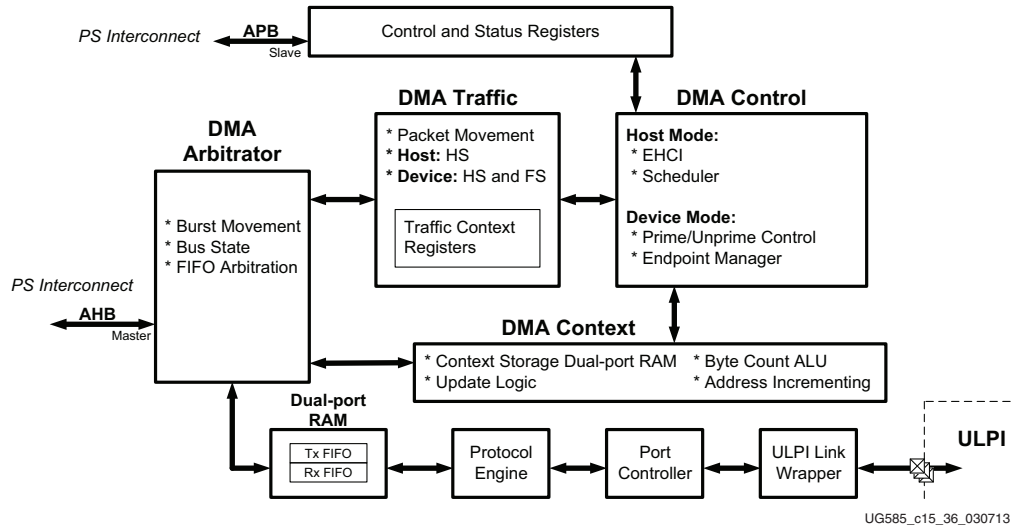

Figure 15-7: USB DMA Controller Block Diagram

15.2.3 Protocol Engine

The protocol engine parses the USB tokens, generates response packets and performs error checking functions. Data packets are passed through the transfer buffers, the DMA engine and system memory.

The controller does not provide a hardware-based Transaction Translator for Low and Full speed operations. Instead, the DMA and Protocol engines are used to support this functionality as described in section 15.11.2 Embedded Transaction Translator.

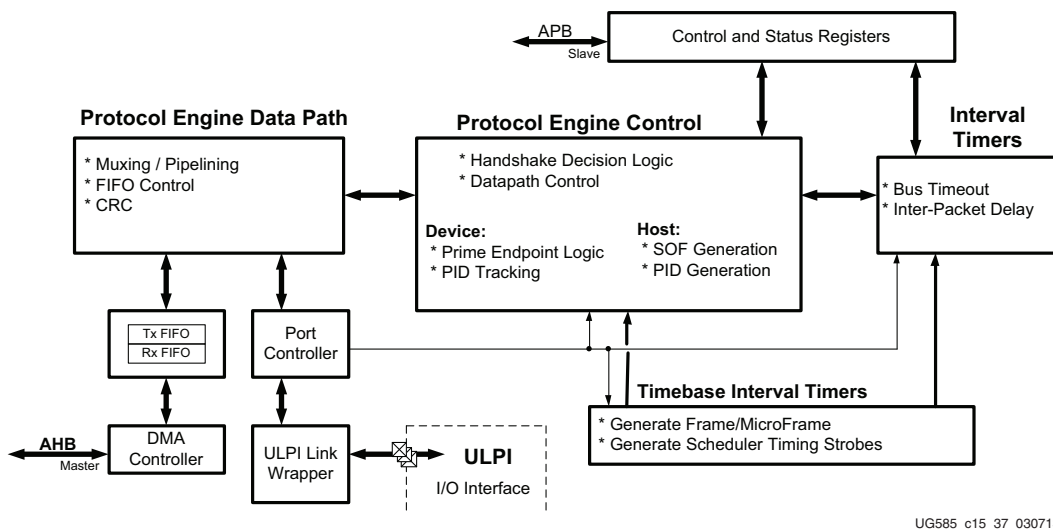

Figure 15-8: USB Protocol Engine Block Diagram

The protocol engine is responsible for all error checking, check field generation, formatting all the handshake, Ping and data response packets on the bus, and for generating signals that are needed based on a USB based time frame.

Protocol Engine Functions

The protocol engine contains several functions for both host and device mode:

- The token state machines track all of the tokens on the bus and filters the traffic based on the address and endpoint information in the token.
- The CRC5 and CRC16 CRC generator/checker circuits check and generate the CRC check fields for the token and data packets.
- The data and handshake state machines generate any responses required on the USB and move the packet data through the dual port RAM to the DMA controller.
- The Interval Timers provide timing strobes that identify important bus timing events: the bus timeout interval, the microframe interval, the start of frame interval, and the bus reset, resume, and suspend intervals.
- Reports all transfer status to the DMA engine.

15.2.4 Port Controller

The port transceiver controller provides a couple of basic functions:

- Suspend/Resume
- For device mode, Chirp control.

15.2.5 ULPI Link Wrapper

The ULPI Link wrapper passes-through packet data and interprets Rx commands as well as send Tx commands and provide viewport services to the software.

The ULPI link wrapper interfaces between the port controller (a bus similar to UTMI+ that connects to the rest of the controller and its registers) and the ULPI interface.

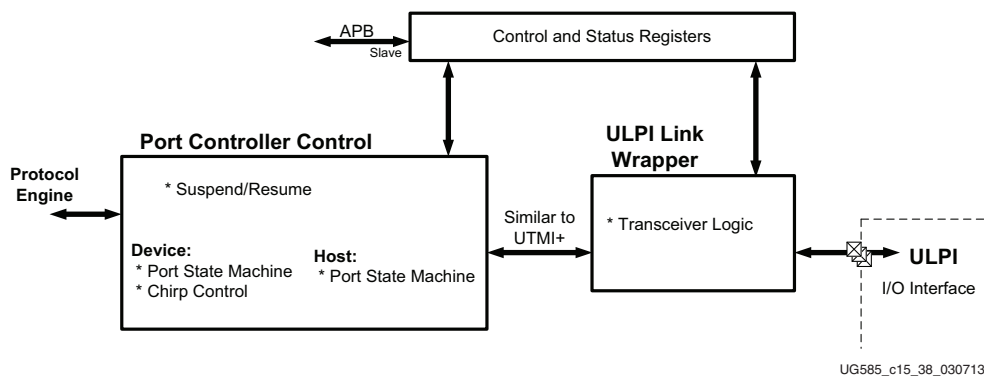

Figure 15-9: USB Port Controller and ULPI Link Wrapper Block Diagram

15.2.6 General Purpose Timers

The two independently programmable timers can be used to generate a timeout or to measure time related activities. The programmable timers should not be confused with the controller's interval timers which are used by the controller to generate frame and microframe intervals and to generate strobes for the host controller scheduler.

A timer is controlled by its control and load registers; `usb.GPTIMERxCTRL` and `usb.GPTIMERxLD`. The load register contains the value that is loaded into the timer when a timer reset occurs.

The control register contains timer configuration and a data field which can be queried to determine the running count value. The timer has granularity of 1 microsecond and can be programmed to count for a little over 16 seconds. There are two modes for this timer; one-shot and looped count. When the timer counter value transitions to 0, an interrupt is controllable using the `usb.USBSTS` and `usb.USBINTR` registers.

The one-shot mode, `usb.GPTIMERxCTRL [GPTMODE] = 0`, selects a single timer countdown where the timer will count down to 0, generate an interrupt and stop until the counter is reset by software.

In repeat, looped countdown, the timer will count down to 0, generate an interrupt and automatically reload the counter from the `usb.GPTIMERxLD` register to begin to count down again.

15.3 Programming Overview and Reference

This section includes an overview of the programming model for host and device modes. The programming model details for each mode are separately described in other sections of the Zynq-7000 SoC Technical Reference Manual (TRM).

Limitation

The USB controller registers require single 32-bit read/write accesses, do not use byte, halfword, or double word references.

15.3.1 Hardware/Software System

The physical and virtual data flows for a USB hardware/software system are illustrated in Figure 15-10. These flows form the basis of USB. The TRM is focused on the operations of the bus interface and device layers as a foundation for writing drivers that include the functional layer.

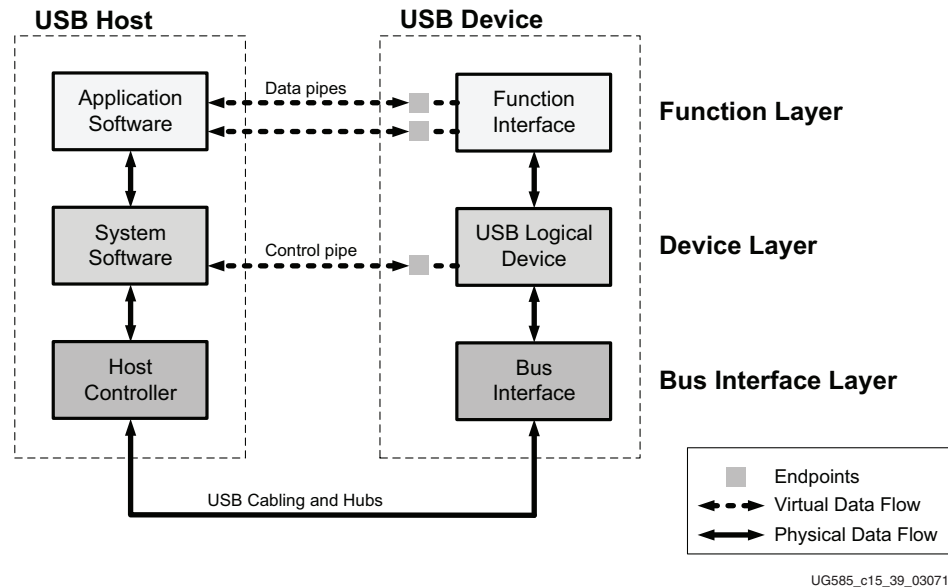

Figure 15-10: USB System Stack

15.3.2 Operational Mode Control

States

The controller can be configured for device mode or host mode. In OTG mode, the controller must perform tasks independent of the device and host controller modes to determine what mode to put the controller into. Software can use the `usb.USBCMD [RST]` reset bit to reset the vast majority of the controller, but preserve register values and controller state to support OTG operations. This reset transitions the controller out of host or device mode and into an idle state as shown in figure Figure 15-11. OTG tasks are performed independent of the [RST] bit reset as well as independent of the controller mode.

The software sets the `usb.USBMODE [CM]` mode bit to select either host or device mode.

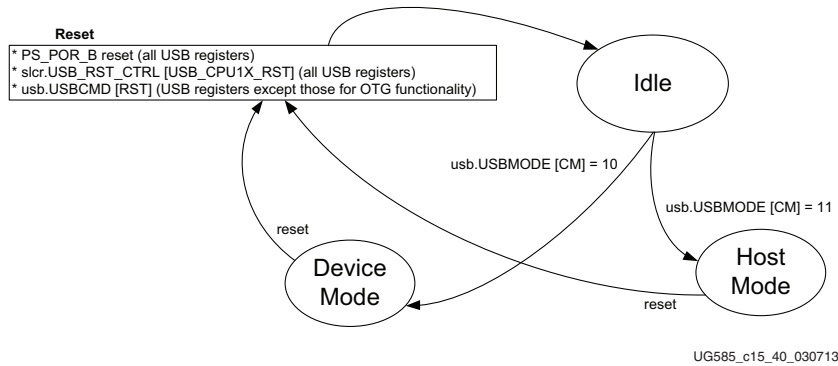

Figure 15-11: USB Controller Mode Diagram

15.3.3 Power Management

Stop-Clock

The USB controller can be held in reset by the PS reset subsystem and the PHY clock from the PHY can be stopped to reduce power consumption. The clocks and resets are described in section 15.15 System Functions.

Suspend and Resume

The USB controller supports Suspend/Resume functions for both host and device modes.

15.3.4 Register Overview

Each controller includes its own set of independent control and status registers that are memory mapped at 0xE000_2000 for controller 0 and at 0xE000_3000 for controller 1. The register address offsets and brief descriptions are summarized in Table 15-1. The detailed descriptions are in Appendix B.

The controller and all registers are reset by the assertion of the USB Ref Reset from the PS. The mechanism is described in Chapter 26, Reset System. The reset value of the controller registers are shown in Appendix B. Software can reset the controller and the non-OTG registers by writing a 1 to the usb.USBCMD [RST] bit. The registers that are reset by usb.USBCMD [RST] are identified in the last column of Table 15-1.

Register Overview Table

The controller registers include configuration constants, capability constants and operational registers for EHCI compatibility (Host mode) and non-EHCI functions (Device and OTG modes). The non-EHCI registers support device mode and OTG functions. The EHCI register fields are overlaid into the controller’s register set.

- **OTG/Mode** registers provide control and status for HNP and SRP.

- **Dev** register is used by the device controller driver software (DCD).
- **Host** register is used by the host controller driver software (HCD).
- **EHCI** register includes content from the specification. 'x' means partial. 'ex' means exclusive.

Table 15-1: USB Controller Register Overview

| Offset Address | Register Name | OTG/ Mode | Dev | Host | EHCI | Type | Affected by USBCMD Reset |
|---|---|-----------|-----|------|------|---------------|--------------------------|
| | Bit Acronym | | | | | | |
| Identification: Configuration Constants. | | | | | | | |
| 0x0000 | ID | x | x | x | | RO | no |
| 0x0004 | HWGENERAL | x | x | x | | RO | no |
| 0x0008 | HWHOST | ~ | ~ | x | | RO | no |
| 0x000C | HWDEVICE | ~ | x | ~ | | RO | no |
| 0x0010 | HWTXBUF | ~ | x | x | | RO | no |
| 0x0014 | HWRXBUF | ~ | x | x | | RO | no |
| General Purpose (GP) Timers. | | | | | | | |
| 0x0080/88 | GPTIMER{0,1}LD | x | x | x | ~ | rw | yes |
| 0x0084/8C | GPTIMER{0,1}CTRL | x | x | x | ~ | mixed | yes |
| AXI Interconnect | | | | | | | |
| 0x0090 | SBUSCFG | x | x | x | ~ | RW | yes |
| Capability: Controller and EHCI Capabilities Constants (IP Configuration Constants). | | | | | | | |
| 0x0100 | CAPLENGTH_HCIVERSION | x | x | x | x | RO | no |
| 0x0104 | HCSPARAMS | x | ~ | x | ex | RO | no |
| 0x0108 | HCCPARAMS | ~ | ~ | x | ex | RO | no |
| 0x0120 | DCIVERSION | x | x | | x | RO | no |
| 0x0124 | DCCPARAMS | x | x | | | RO | no |
| Operational: Interrupts, Schedule Pointers (Host), and Endpoint Pointers (Device). | | | | | | | |
| 0x0140 | USBCMD | x | x | x | x | RW | yes |
| 0x0144 | USBSTS, refer to Table 15-2 . | x | x | x | x | RW, R/W1C, RO | yes, except RO |
| 0x0148 | USBINTR | x | x | x | ex | RW, R/W1C, RO | yes, except RO |
| 0x014C | FRINDEX | ~ | x | x | x | RW | yes |
| 0x0154 | PERIODICLISTBASE_ | ~ | ~ | x | ex | RW | yes |
| | _DEVICEADDR | ~ | x | ~ | ~ | RW | yes |
| 0x0158 | ASYNCLISTADDR_ | ~ | ~ | x | ex | RW | yes |
| | _ENDPOINTLISTADDR | ~ | x | ~ | ~ | RW | yes |
| Operational: Transaction Translator. | | | | | | | |
| 0x015C | TTCTRL | ~ | ~ | x | ~ | RW, RO | yes, except RO |
| Operational: Misc. | | | | | | | |
| 0x0160 | BURSTSIZE | x | x | x | ~ | RW | yes |
| 0x0164 | TXFILLTUNING | | | | | RW, R/W1C | yes |
| 0x0168 | TXTFILLTUNING | | | | | RW, R/W1C | yes |
| 0x016C | IC_USB | x | x | x | ~ | RW | yes |
| 0x0170 | ULPI_VIEWPORT | x | x | x | ~ | RW, RO | yes, except RO |
| Operational: Endpoint Control (Device mode), refer to Figure 15-4 for details. | | | | | | | |

Table 15-1: USB Controller Register Overview (Cont'd)

| Offset Address | Register Name | OTG/ Mode | Dev | Host | EHCI | Type | Affected by USBCMD Reset |
|--|---------------------|-----------|-----|------|------|---------------|--------------------------|
| | Bit Acronym | | | | | | |
| 0x0178 | ENDPTNAK | | x | ~ | ~ | R/WTC | |
| 0x017C | ENDPTNAKEN | | x | ~ | ~ | RW | |
| Operational: Host mode (EHCI) and Device mode. | | | | | | | |
| 0x0180 | CONFIGFLAG | x | x | x | x | RO | |
| 0x0184 | PORTSC1 | x | x | x | x | RW, RO, R/W1C | partial |
| | [WKDS] [WKN] [WKOC] | | | | | | no |
| | [PIC] [PR] | | | | | | no |
| | others | | | | | | yes |
| Operational: Mode Control. | | | | | | | |
| 0x01A4 | OTGSC | x | ~ | ~ | ~ | RW, RO, R/W1C | no |
| 0x01A8 | USBMODE | x | x | x | ~ | RW | yes |
| Endpoint Configuration and Control (Device mode), refer to Figure 15-4 for details. | | | | | | | |
| 0x01AC | ENDPTSETUPSTAT | ~ | x | ~ | ~ | R/W1C | yes |
| 0x01B0 | ENDPTPRIME | ~ | x | ~ | ~ | R/W1S | yes |
| 0x01B4 | EMDPTFLUSH | ~ | x | ~ | ~ | R/W1S | yes |
| 0x01B8 | ENDPTSTAT | ~ | x | ~ | ~ | RO | no |
| 0x01BC | ENDPTCOMPLETE | ~ | x | ~ | ~ | R/W1C | yes |
| 0x01C0 | ENDPTCTRL 0 | ~ | x | ~ | ~ | RW, RO | yes, except RO |
| 0x01C4 to 0x01EC | ENDPTCTRL {1 to 11} | ~ | x | ~ | ~ | RW, R/W1C | yes |

15.3.5 Interrupt and Status Bits Overview

Each controller has a IRQ interrupt signal to the PS interrupt controller that is an accumulation of enable interrupts listed in [Table 15-2](#) except for some Status-only bit that can't generate an interrupt.

- Controller 0: IRQ ID #53
- Controller 1: IRQ ID #76

USBSTS Interrupt, Status and Enable Registers

The interrupt and status bits of the usb.USBSTS registers are listed in [Table 15-2 USB Interrupt and Status Register Bits](#). The interrupt bits are maskable using the usb.USBINTR registers. The status bits do not generate an interrupt and are read-only to provide status information to software.

Table 15-2: USB Interrupt and Status Register Bits

| USBSTS (status) Bit Field | | Type | USBINTR (enable) Bit Field | Description | Dev | Host | Cross Reference |
|---------------------------|----|-------------|----------------------------|----------------------------------|-----|------|-------------------------------|
| [TI1] | 25 | Interrupt | 25 | Timer 1. | x | x | 15.2.6 General Purpose Timers |
| [TI0] | 24 | Interrupt | 24 | Timer 0. | x | x | |
| [UPI] | 19 | Interrupt | 19 | Periodic qTD complete. | ~ | x | |
| [UAI] | 18 | Interrupt | 18 | Async qTD complete. | ~ | x | |
| [NAKI] | 16 | Interrupt | 16 | Device generated NAK. | x | ~ | |
| [AS] | 15 | Status-only | na | Async Schedule state. | ~ | x | |
| [PS] | 14 | Status-only | na | Periodic Schedule state. | ~ | x | |
| [RCL] | 13 | Status-only | na | Host Reclamation status. | ~ | x | |
| [HCH] | 12 | Status-only | na | Halt status of Run/Stop. | | | |
| [ULPII] | 10 | Interrupt | 10 | ULPI Viewport transfer complete. | x | x | |
| [SLI] | 8 | Interrupt | 8 | Device enters Suspend state. | x | ~ | |
| [SRI] | 7 | Interrupt | 7 | Start of Frame (SOF) received. | x | ~ | Table 15-17 |
| [URI] | 6 | Interrupt | 6 | Reset received. | x | ~ | |
| [AAI] | 5 | Interrupt | 5 | Async schedule advance. | ~ | x | |
| [SEI] | 4 | Interrupt | 4 | System Error response on AHB. | x | x | |
| [FRI] | 3 | Interrupt | 3 | Periodic Frame List rollover. | ~ | x | |
| [PCI] | 2 | Interrupt | 2 | Port Change Detect. | x | x | |
| [UEI] | 1 | Interrupt | 1 | USB Transaction Error. | | | |
| [UI] | 0 | Interrupt | 0 | TD complete | x | | Table 15-17 |

15.3.6 OTG Status/Interrupt and Control Register

The programming model for On-the-Go (OTG) USB is supported by the OTG status and control register (OTGSC). The OTG operation works independently of the host and device modes. In OTG mode, once the controller has determined which mode to operate in, the full features of that mode (host or device) are available to the software. Please refer to [15.14.2 OTG Interrupt and Control Bits](#).

15.4 Device Mode Control

When the controller is in device mode, software enables its control endpoint, prepares descriptors based on the functionality of the device and prepares the necessary endpoints.

15.4.1 Controller State

The device mode includes the active physical state of the controller, left side of Figure 15-12, and the suspend state maintained in software, right side of the figure. Power interruptions, resets and USB activity all contribute to the sequencing through these states.

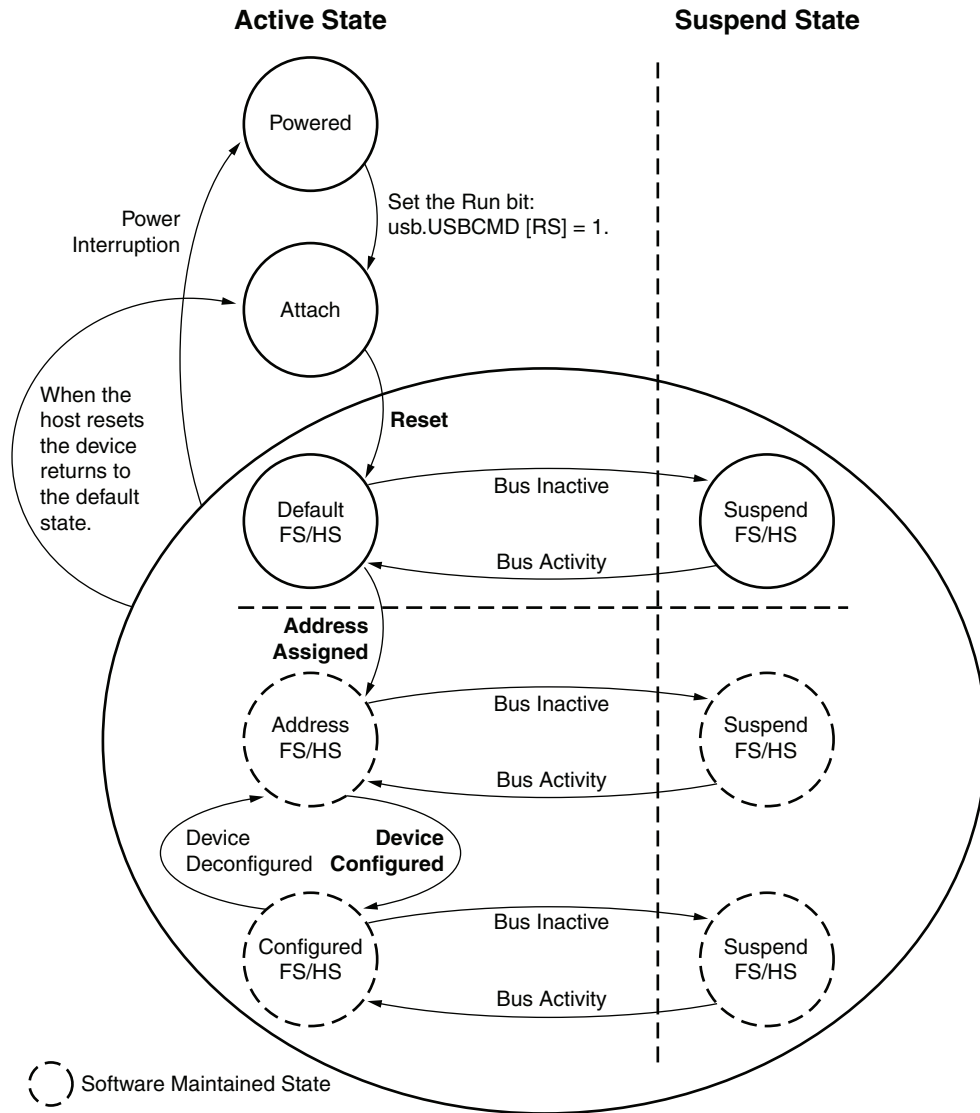

UG585_c15_12_030413

Figure 15-12: USB Device State Diagram

It is the responsibility of software to maintain a state variable to differentiate between the default FS/HS state and the address/configured states. Change of state from default to address and the configured states is part of the enumeration process described in the device framework section of the USB 2.0 Specification.

Table 15-3: USB Device State Information Bits

| Bit Description | Register Bit | Interrupt |
|--------------------|--------------------|-----------|
| Suspend Mode | usb.USBSTS [SLI] | Yes |
| USB Reset Received | usb.USBSTS [URI] | Yes |
| Port Change Detect | usb.USBSTS [PCI] | Yes |
| High-Speed Port | usb.PORTSC1 [PSPD] | No |

As a result of entering the address state, the device address register (usb._DEVICEADDR) must be programmed by the DCD.

Entry into the configured state indicates that all endpoints to be used in the operation of the device have been properly initialized by programming the usb.ENDPTCTRLx registers and initializing the associated queue heads.

15.4.2 USB Bus Reset Response

A USB bus reset is used by the host to initialize downstream devices. The USB reset is one of several types of resets in the system, refer to section 15.15.2 [Reset Types](#) for a list.

When a bus reset is detected, the device controller hardware renegotiates its attachment speed, reset the device address to 0 and notify the DCD by interrupt (assuming the USB reset interrupt enable is set). After a reset is received, all endpoints (except EP 0) are disabled and any primed transactions are canceled by the device controller. The concept of priming will be clarified below, but the DCD must perform the following tasks when a reset is received.

DCD Actions

1. Clear all setup token semaphores by reading the usb.ENDPTSETUPSTAT register and writing the same value back to the usb.ENDPTSETUPSTAT register. Clear all the endpoint complete status bits by reading the usb.ENDPTCOMPLETE register and writing the same value back to the usb.ENDPTCOMPLETE register.
2. Cancel all primed status by waiting until all bits in the usb.ENDPTPRIME register are 0 and then writing `FFFF_FFFFh` to usb.ENDPTFLUSH register.
3. Read the reset bit in the PORTSC1 register and make sure that it is still active. A USB reset occurs for a minimum of 3 ms and software must reach this point in the reset cleanup before end of the reset occurs, otherwise a hardware reset of the device controller is recommended (rare).

Device Controller Reset

4. A hardware reset can be performed by writing a 1 to the usb.USBCMD [RST] reset bit. A hardware reset will cause the device to detach from the bus by clearing the run/stop bit. Thus, software must completely re-initialize the device controller after a hardware reset.
5. Free all allocated dTD's because they will no longer be executed by the device controller. If this is the first time the DCD is processing a USB reset event, then it is likely that no dTD's have been allocated.

At this time, the DCD might release control back to the OS because no further changes to the device controller are permitted until a port change detect is indicated.

Port Change Detect

After a port change detect, the device has reached the default state and the DCD can read the PORTSC1 register to determine if the device is operating in FS or HS mode. At this time, the device controller has reached normal operating mode and the DCD can respond to enumeration according to the USB2.0 specification Chapter 9 - *Device Framework*.

The DCD can use the FS/HS mode information to determine the bandwidth mode of the device.

Note: Before resume signaling can be used, the host must be enabled using the Set Feature command defined in device framework of the *USB 2.0 Specification*.

Note: It is necessary for the DCD to use the flush bit(s) to de-prime one or more endpoints when a USB device reset is received. Refer to [Example: Flushing/De-priming an Endpoint, page 443](#).

15.5 Device Endpoint Data Structures

The device endpoint data structures consist of link-list endpoint descriptors that must be initialized and managed by software. This consists of programming the endpoint control registers, maintaining a set of descriptors in system memory, and managing system memory buffers.

15.5.1 Link-list Endpoint Descriptors

There are two types of descriptors used for the device controller: the device Queue Head (dQH) and the device Transfer Descriptor (dTD). [Figure 15-13](#) shows how these are used in a link-list fashion. The DMA engine uses link-list descriptors to respond to endpoint packet transfer requests from the host.

It is necessary for the DCD to maintain head and tail pointers to the linked list of dTD's for each respective queue head. This is necessary because the dQH only maintains pointers to the current working dTD and the next dTD to be executed. The operations described in next section for managing dTD will assume the DCD can reference the head and tail of the dTD linked list.

Note: To conserve memory, the reserved fields at the end of the dQH can be used to store the Head and Tail pointers but it still remains the responsibility of the DCD to maintain the pointers.

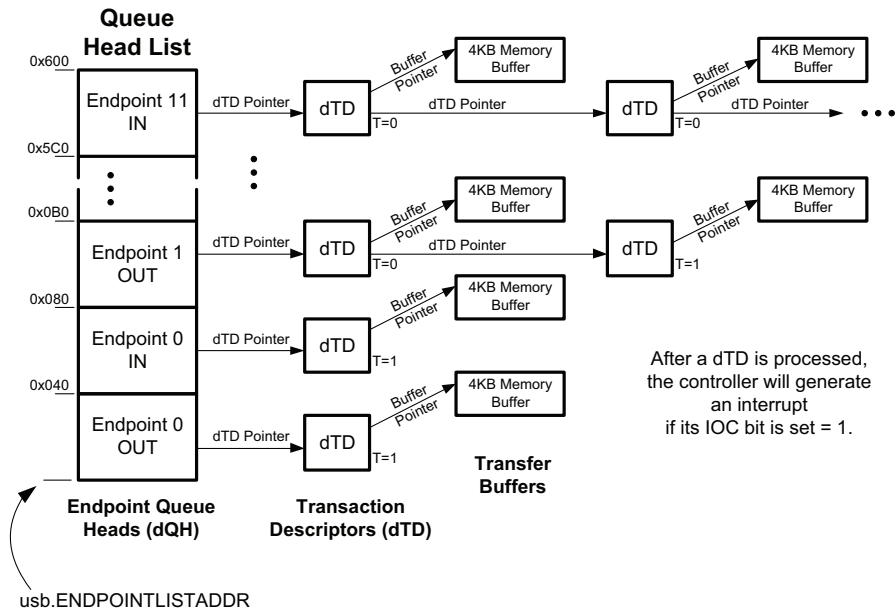

UG585_c15_41_030713

Figure 15-13: USB Device Link-list Endpoints Example

The device controller API software incorporates and abstracts for the application developer all of the information contained in the device operational model. Each Endpoint can be configured for bi-directional transfers (contain both IN and OUT endpoints).

Queue Head and Linked Transfer Descriptors:

- [15.7.1 Endpoint Queue Head Descriptor \(dQH\)](#)
- [15.7.2 Endpoint Transfer Descriptor \(dTD\)](#)
- [15.7.3 Endpoint Transfer Overlay Area](#)

Descriptor and Data Flow

The top portion of [Figure 15-14](#) shows the list of queue heads (one for each endpoint) and the list of transfer descriptors that are referenced by the dQH and other dTD descriptors. The low portion of the figure shows data being transferred between memory and the ULPI connection to USB.

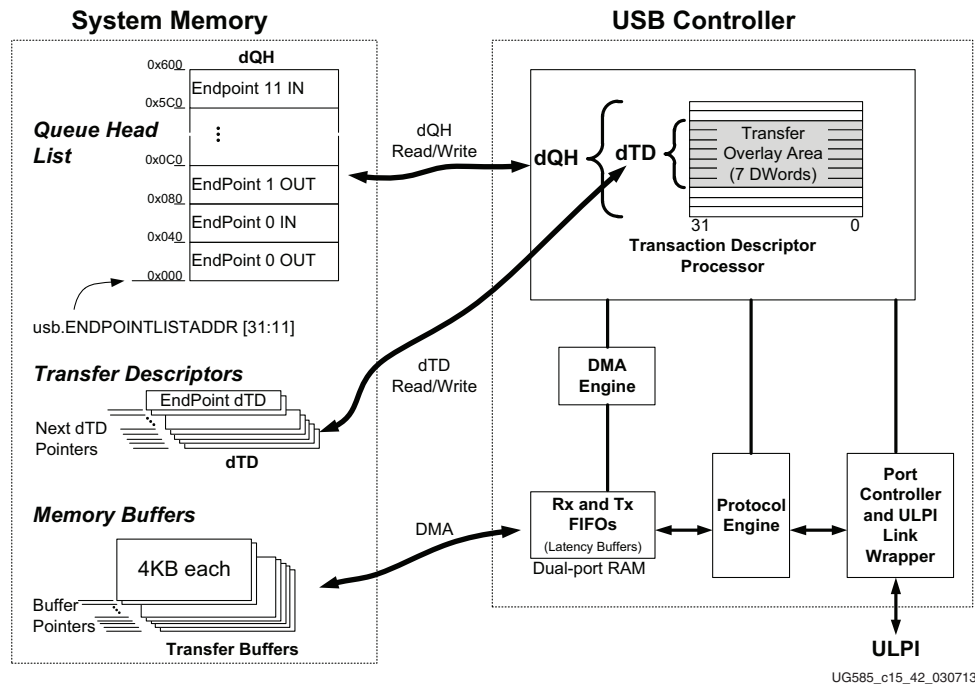

Figure 15-14: USB Device Descriptor and Data Flow

15.5.2 Manage Endpoints

The *USB 2.0 Specification* defines an endpoint, also called a device endpoint or an address endpoint as a uniquely addressable portion of a USB device that can source or sink data in a communications channel between the host and the device. The endpoint address is specified by the combination of the endpoint number and the endpoint direction.

The channel between the host and an endpoint at a specific device represents a data pipe. Endpoint 0 for a device is always a control type data channel used for device discovery and enumeration. Other types of endpoints support by USB include bulk, interrupt, and isochronous. Each endpoint type has specific behavior related to packet response and error handling. More detail on endpoint operation can be found in the *USB 2.0 Specification*.

The device controller hardware is configured to support up to 12 endpoints. The DCD can enable, disable and configure endpoint type up to the maximum selected during synthesis.

Each endpoint direction is essentially independent and can be configured with differing behavior in each direction. For example, the DCD can configure endpoint 1 IN to be a bulk endpoint and endpoint 1 OUT to be an isochronous endpoint. This helps to conserve the total number of endpoints required for device operation. The only exception is that control endpoints must use both directions on a single endpoint number to function as a control endpoint. Endpoint 0, for example, is always a control endpoint and uses the pair of directions.

Each endpoint direction requires a queue head allocated in memory. For 12 endpoints, numbers is used, then 24 queue heads are required one for each endpoint direction being used by the device

controller. The operation of an endpoint and use of queue heads are described later in this document.

15.5.3 Endpoint Registers

The endpoint registers are listed in [Table 15-4 USB Device Endpoint Register Summary](#). These registers were summarized at the end of [Table 15-1, page 414](#).

In general, there is one bit for each endpoint. The lower half of the register bits are for Rx endpoints and the upper half is for Tx endpoints. Exceptions include the ENDPTSETUPSTAT and the endpoint control registers, ENDPTCTRL{11:0}.

Endpoint Registers

Table 15-4: USB Device Endpoint Register Summary

| Register Name | Description and Register Bit Field | | Type |
|-----------------------|---|-------------------------------------|------------------------------|
| | Tx Endpoint (11:0) | Rx Endpoint (11:0) | |
| ENDPTNAK | Bit is set when an endpoint sends a NAK to the Host. [EPTN], 27:16 (IN token) | [EPRN], 11:0 (OUT or Ping token) | Read and Write-one-to-clear. |
| ENDPTNAKEN | Interrupt enable bits for ENDPTNAK bits. [EPTNE], 27:16 | [EPRNE], 11:0 | Read/Write. |
| ENDPTSETUPSTAT | Bit is set when an endpoint receives a Setup transaction. ~ | [ENDPTSETUPSTAT], 11:0 | Read and Write-one-to-clear. |
| ENDPTPRIME | Software sets a bit to instruct the controller to prepare for a packet transfer. The QH, dTD's, and endpoint registers are ready. [PETB], 27:16 (IN or Interrupt) | [PERB], 11:0 (OUT) | Read and Write-one-to-set. |
| ENDPTFLUSH | Software sets a bit to instruct the controller to flush an endpoint. Note: Flushing an endpoint in the controller also causes the endpoint to be de-primed (the endpoint must be completely re-initialized to continue the transaction). [FETB], 27:16 | [FERB], 11:0 | Read and Write-one-to-set. |
| ENDPTSTAT | Indicates that the controller hardware has primed the endpoint as requested by the ENDPTPRIME register. [ETBR], 27:16 | [ERBR], 11:0 | Read-only. |
| ENDPTCOMPLETE | Indicates that the controller has completed the transfer that was primed. [ETCE], 27:16 | [ERCE], 11:0 | Read and Write-one-to-clear. |

Endpoint Configuration Registers

Table 15-5: USB Device Endpoint Configuration Register Summary

| Register Name | Description and Register Bit Field | | Type |
|---|---|-------------|-------------|
| | Tx | Rx | |
| ENDPTCTRL0 | Software can control the STALL behavior for Rx and Tx transactions to the control endpoint. Software can read the control endpoint configuration. | | (see below) |
| | [TXS], 16 | [RXS], 0 | Read-write. |
| | Others: always enabled, Tx and Rx capable. | | Read-only. |
| ENDPTCTRL {11:0} | Software configuration and control bits for each endpoint. Refer to Table 15-6, page 423 . | | Read-write. |
| | Force controller to send Stall responses. | | |
| | [TXS], 16 | [RXS], 0 | |
| | Always set = 0 (datapath includes FIFOs). | | |
| | [TXS], 17 | [RXS], 1 | |
| | Select endpoint type (Control, ISO, Bulk, Interrupt). | | |
| | [TXS], 19:18 | [RXS], 3:2 | |
| Always set = 0 (test mode to ignore data toggling). | | Write-one. | |
| [TXS], 21 | [RXS], 5 | | |
| Data toggle reset (write 1 to synchronize data PIDs). | | Read-write. | |
| [TXS], 22 | [RXS], 6 | | |
| Endpoint enable. | | Read-write. | |
| [TXS], 23 | [RXS], 7 | | |

15.5.4 Endpoint Initialization

After hardware reset, all endpoints except endpoint 0 are uninitialized and disabled. The DCD must configure and enable each endpoint by writing to the configuration register `usb.ENDPTCTRLx`. Each 32-bit `usb.ENDPTCTRLx` is split into an upper and lower half. The lower half of `usb.ENDPTCTRLx` register is used to configure the receive or OUT endpoint and the upper half is likewise used to configure the corresponding transmit or IN endpoint. Control endpoints must be configured the same in both the upper and lower half of the `usb.ENDPTCTRLx` register otherwise the behavior is undefined. [Table 15-6](#) shows how to construct a configuration word for endpoint initialization.

Table 15-6: USB Device Endpoint Initialization

| Field | Value | Meaning |
|--|-------|--------------------------------------|
| Data Toggle Reset, <code>usb.ENDPTCTRLx [TXR]</code> | 1 | Restart transfers with DATA0 PID. |
| Data Toggle Inhibit, <code>usb.ENDPTCTRLx [TXI]</code> | 0 | Toggle between DATA0 and DATA1 PIDs. |

Table 15-6: USB Device Endpoint Initialization (Cont'd)

| Field | Value | Meaning |
|--------------------------------------|-------------------------------|---|
| Endpoint Type, usb.ENDPTCTRLx [TXT] | Depends on the setup request. | 00: Control 01: Isochronous 10: Bulk 11: Interrupt |
| Endpoint Stall, usb.ENDPTCTRLx [TXS] | 0 | Do not force stall response. |

Stall

There are two occasions where the device controller might need to return a STALL to the host:

- Functional Stall: software initiated (non-control endpoints only).
- Protocol Stall: hardware initiates (control endpoint).

The functional stall, which is a condition set by the DCD as described in the USB 2.0 device framework. A functional stall is only used on non-control endpoints and can be enabled in the device controller by setting the usb.ENDPTCTRLx [TXS] stall bit associated with the given endpoint and the given direction. In a functional stall condition, the device controller will continue to return STALL responses to all transactions occurring on the respective endpoint and direction until the endpoint stall bit is cleared by the DCD.

A protocol stall, unlike a function stall, is used on control endpoints and automatically cleared by the device controller at the start of a new control transaction (setup phase). When enabling a protocol stall, the DCD should enable the stall bits (both directions) as a pair. A single write to the usb.ENDPTCTRLx register can ensure that both stall bits are set at the same instant.

Note: Any write to the usb.ENDPTCTRLx register during operational mode must preserve the endpoint type field (i.e. perform a read-modify-write of this register and preserve the [TXT] field).

Table 15-7: USB Device Packet Mismatch Response

| USB Packet Type Received | Endpoint Type | Stall Bit setting [TXS] | Hardware action on Stall bit | Bus Response |
|--------------------------|---------------|-------------------------|------------------------------|--------------|
| Setup | Control | x | Clears [TXS] | ACK |
| | Non-Control | x | None | STALL |
| IN/OUT/Ping | All | 0 | None | ACK/NAK/NYET |
| | All | 1 | None | STALL |

Data Toggle

Data toggle is a mechanism to maintain data ordering between the host and device for a given data pipe. For more information on data toggle, refer to the USB 2.0 specification.

The DCD can reset the data toggle state bit and cause the data toggle sequence to reset in the device controller by writing a 1 to the data toggle reset bit in the usb.ENDPTCTRLx [TXR] register bit. This should only be necessary when configuring/initializing an endpoint or returning from a STALL condition.

Data Toggle Inhibit

This feature is for test purposes only and should never be used during normal device controller operation. Setting the data toggle inhibit bit active (usb.ENTPTCTRLx [RXI] bit = 1) causes the device controller to ignore the data toggle pattern that is normally sent and accept all incoming data packets regardless of the data toggle state.

In normal operation, the device controller checks the DATA0/DATA1 bit against the data toggle to determine if the packet is valid. If Data PID does not match the data toggle state bit maintained by the device controller for that endpoint, the Data toggle is considered not valid. If the data toggle is not valid, the device controller assumes the packet was already received and discards the packet (not reporting it to the DCD). To prevent the host controller from re-sending the same packet, the device controller will respond to the error packet by acknowledging it with either an ACK or NYET response.

15.6 Device Endpoint Packet Operational Model

All transactions on the USB bus are initiated by the host and in turn, the device must respond to any request from the host within the turnaround time stated in the *USB 2.0 Specification*. At USB 1.1 Full or Low Speed rates, this turnaround time was significant and the USB 1.1 device controllers were designed so that the device controller could access main memory or interrupt a host protocol processor in order to respond to the USB 1.1 transaction. The architecture of the USB 2.0 device controller must be different because the same methods will not meet USB 2.0 High-speed turnaround time requirements.

A USB host sends requests to the device controller in an order that cannot be precisely predicted as a single pipeline, so it is not possible to prepare a single packet for the device controller to execute. However, the order of packet requests is predictable when the endpoint number and direction is considered. For example, if endpoint 3 (transmit direction) is configured as a bulk pipe, then we can expect the host will send IN requests to that endpoint.

Prime and Flush Endpoints

This device controller is designed in such a way that it can prepare packets for each endpoint or direction in anticipation of the host request. The process of preparing the device controller to send or receive data in response to host initiated transaction on the bus is referred to as '*priming*' the endpoint. The term '*flushing*' is used to describe the action of clearing a packet that was queued for execution.

Note: Flushing an endpoint in the controller also causes the endpoint to be de-primed (the endpoint must be completely re-initialized to continue the transaction).

15.6.1 Prime Transmit Endpoints

Priming a transmit endpoint will cause the device controller to fetch the dTD for the transaction pointed to by the dQH. After the dTD is fetched, it will be copied in the dQH until the device controller completes the transfer described by the dTD. Copying the dTD in the dQH overlay area

allows the device controller to fetch the operating context needed to handle a request from the host without the need to follow the linked list, starting at the dQH when the host request is received.

After the device has loaded the dTD, the leading data in the packet is stored in a FIFO in the device controller. This FIFO is split into virtual channels so that the leading data can be stored for any endpoint up to the maximum number of endpoints configured at device synthesis time.

After a priming request is complete, an endpoint state of primed is indicated in the ENDPTSTATUS register. For a primed transmit endpoint, the device controller can respond to an IN request from the host and meet the stringent bus turnaround time of High Speed USB.

Since only the leading data is stored in the device controller FIFO, it is necessary for the device controller to begin filling in behind leading data after the transaction starts. The FIFO must be sized to account for the maximum latency that can be incurred by the system memory bus.

15.6.2 Prime Receive Endpoints

Priming receive endpoints is identical to priming of transmit endpoints from the point of view of the DCD. At the device controller the major difference in the operational model is that there is no data movement of the leading packet data simply because the data is to be received from the host.

Note as part of the architecture, the FIFO for the receive endpoints is not partitioned into multiple channels like the transmit FIFO. Thus, the size of the RxFIFO does not scale with the number of endpoints.

15.6.3 Interrupt and Bulk Endpoint Operational Model

The behaviors of the device controller for interrupt and bulk endpoints are identical. All valid IN and OUT transactions to bulk pipes will handshake with a NAK unless the endpoint had been primed. Once the endpoint has been primed, data delivery will commence.

A dTD will be retired by the device controller when the packets described in the transfer descriptor have been completed. Each dTD describes N packets to be transferred according to the USB Variable Length transfer protocol. The formula and table on the following page describe how the device controller computes the number and length of the packets to be sent/received by the USB vary according to the total number of bytes and maximum packet length.

With Zero Length Termination dTD.ZLT = 0,
$$N = \text{INT}(\text{Number of Bytes}/\text{Max. Packet Length}) + 1$$

With Zero Length Termination dTD.ZLT = 1,
$$N = \text{MAXINT}(\text{Number of Bytes}/\text{Max. Packet Length})$$

Table 15-8: USB Device Variable Length Transfer Protocol Examples

| Bytes dTd | Max. Packet Length dQH | dTd.ZLT = 0 | | | | dTd.ZLT = 1 | | | |
|--------------|------------------------------|-------------|-----|-----|----|-------------|-----|-----|----|
| | | N | P1 | P2 | P3 | N | P1 | P2 | P3 |
| 511 | 256 | 2 | 256 | 256 | | 2 | 256 | 256 | |
| 512 | 256 | 3 | 256 | 256 | 0 | 2 | 256 | 256 | |
| 512 | 512 | 2 | 512 | 0 | | 1 | 512 | | |

Note: The dQH.Mult field must be set to 00 for Bulk, Interrupt, and Control endpoints.

The dQH.ZLT bit operates as follows on Bulk and Control transfers:

dQH.ZLT = 0, the default value

The zero length termination is active. With the dQH.ZLT option enabled, when the device is transmitting, the hardware automatically appends a zero length packet when the following conditions are true:

- The packet transmitted equals maximum packet length
- The dTD has exhausted the field Total Bytes

After this the dTD will be retired. When the device is receiving, if the last packet length received equal maximum packet length and the total bytes is 0, it will wait for a zero length packet from the host to retire the current dTD.

dQH.ZLT = 1

The zero length termination is inactive. With the dQH.ZLT option disabled, when the device is transmitting, the hardware will not append any zero length packet. When receiving, it will not require a zero length packet to retire a dTD whose last packet was equal to the maximum packet length packet. The dTD is retired as soon as total bytes field goes to 0, or a short packet is received.

Each transfer is defined by one dTD, so the zero length termination is for each dTD.

In some software application cases, the logic transfer does not fit into just one dTD, so it does not make sense to add a zero length termination packet each time a dTD is consumed. On those cases we recommend to turn off this dQH.ZLT feature and use the DCD to generate the zero length termination.

Tx dTD Completes

- All packets described in the dTD were successfully transmitted. Total bytes in dTD equals 0 when this occurs.

Rx dTD Completes

- All packets described in dTD were successfully received. Total bytes in dTD equals 0 when this occurs.
- A short packet (number of bytes < maximum packet length) was received. This is a successful transfer completion; the DCD must check Total Bytes in dTD to determine the number of bytes that are remaining. From the total bytes remaining in the dTD, the DCD can compute the actual bytes received.
- A long packet was received (number of bytes > maximum packet size) OR (total bytes received > total bytes specified). This is an error condition. The device controller will discard the remaining packet, and set the Buffer Error bit in the dTD. In addition, the endpoint will be flushed and the USBERR interrupt will become active.

On the successful completion of the packet(s) described by the dTD, the active bit in the dTD will be cleared and the next pointer will be followed when the Terminate bit is clear. When the Terminate bit is set, the device controller will flush the endpoint/direction and cease operations for that endpoint/direction.

On the unsuccessful completion of a packet (see long packet above), the dQH is left pointing to the dTD that was in error. In order to recover from this error condition, the DCD must properly reinitialize the dQH by clearing the active bit and update the next dTD pointer before attempting to re-prime the endpoint.

Note: All packet level errors such as a missing handshake or CRC error are retried automatically by the device controller.

There is no required interaction with the DCD for handling such errors.

Interrupt and Bulk Endpoint Bus Response

The shaded column in [Table 15-9](#) is the normal operating mode.

Table 15-9: USB Device Interrupt and Bulk Endpoint Bus Response

| Packet Identifier | Stall Bit [TXS] | Endpoint Not Primed | Endpoint Primed | Buffer Underflow | Buffer Overflow | Endpoint Not Enabled |
|-------------------|-----------------|---------------------|---------------------------|------------------|-----------------|----------------------|
| Setup | Ignore | Ignore | Ignore | N/A | N/A | BTO |
| IN | STALL | NAK | Transmit | BS Error | N/A | BTO |
| OUT | STALL | NAK | Receive and then NYET/ACK | N/A | NAK | BTO |
| Ping | STALL | NAK | ACK | N/A | N/A | BTO |

Table 15-9: USB Device Interrupt and Bulk Endpoint Bus Response (Cont'd)

| Packet Identifier | Stall Bit [TXS] | Endpoint Not Primed | Endpoint Primed | Buffer Underflow | Buffer Overflow | Endpoint Not Enabled |
|-------------------|-----------------|---------------------|-----------------|------------------|-----------------|----------------------|
| Invalid | Ignore | Ignore | Ignore | Ignore | Ignore | BTO |

Notes:

1. BS Error — Force Bit Stuff Error.
2. NYET/ACK — NYET unless the Transfer Descriptor has packets remaining according to the USB variable length protocol then ACK.
3. SYSERR — System error should never occur when the latency FIFOs are correctly sized and the DCD is responsive.
4. BTO — Bus Time Out.

15.6.4 Isochronous Endpoint Operational Model

Isochronous endpoints are used for real-time scheduled delivery of data and their operational model is significantly different than the host throttled bulk, interrupt, and control data pipes. Real time delivery by the device controller is accomplished by the following:

- Exactly MULT Packets per (micro)frame are transmitted/received.

Note: MULT is a two-bit field in the device queue head. The variable length packet protocol is not used on isochronous endpoints.

- NAK responses are not used. Instead, zero length packets are sent in response to an IN request to an unprimed endpoints. For unprimed Rx endpoints, the response to an OUT transaction is to ignore the packet within the device controller.
- Prime requests always schedule the transfer described in the dTD for the next (micro)frame. If the ISO-dTD is still active after that frame, then the ISO-dTD is held ready until executed or canceled by the DCD.

Note: If the MULT field is set to more packets than present in the dTD to be transmitted, the controller sends zero length packets to all extra incoming IN tokens and report fulfillment error (transaction error) in current dTD. If more dTD's exist in memory, the controller moves to the next dTD to be transmitted in the next (micro)frame. Because of this behavior it is recommended to always use the correct MULT matching the number of packets to be processed for a given dTD.

An EHCI compatible host controller uses the periodic frame list to schedule data exchanges to Isochronous endpoints. The operational model for the device controller does not use such a data structure. Instead, the same dTD used for Control/Bulk/Interrupt endpoints is also used for isochronous endpoints. The difference is in the handling of the dTD.

The first difference between bulk and iso endpoints is that priming an iso endpoint is a delayed operation such that an endpoint will become primed only after a SOF is received. After the DCD writes the prime bit, the prime bit will be cleared as usual to indicate to the DCD that the device controller completed a priming the dTD for transfer. Internal to the design, the device controller hardware masks that prime start until the next frame boundary. This behavior is hidden from the DCD but occurs so that the device controller can match the dTD to a specific (micro)frame.

Another difference with isochronous endpoints is that the transaction must wholly complete in a (micro)frame. Once an isochronous transaction is started in a (micro)frame it will retire the

corresponding dTD when MULT transactions occur or the device controller finds a fulfillment condition.

The transaction error bit set in the status field indicates a fulfillment error condition. When a fulfillment error occurs, the frame after the transfer failed to complete wholly, the device controller will force retire the iso dTD and move to the next iso dTD.

It is important to note that fulfillment errors are only caused due to partially completed packets. If no activity occurs to a primed iso endpoint, the transaction will stay primed indefinitely. This means it is up to the DCD to discard transmit iso dTD's that pile up from a failure of the host to move the data.

Finally, the last difference with iso packets is in the data level error handling. When a CRC error occurs on a received packet, the packet is not retried similar to bulk and control endpoints. Instead, the CRC is noted by setting the Transaction Error bit and the data is stored as usual for the application software to sort out.

Tx Isochronous Packet Retired

The Tx Packet is retired when:

- MULT counter reaches 0.
- Fulfillment Error [Transaction Error bit is set]

Packets Occurred > 0 AND # Packets Occurred < MULT

Note: For Tx isochronous endpoint, the MULT Counter can be loaded with a lesser value in the dTD Multiplier Override field. If the Multiplier Override is 0, the MULT Counter is initialized to the dQH.Mult field.

Rx Isochronous Packet Retired

The Rx Packet is retired when:

- MULT counter reaches 0.
- Non-MDATA Data PID is received
- Overflow Error:

Packet received is > maximum packet length. [Buffer Error bit is set]

Packet received exceeds total bytes allocated in dTD. [Buffer Error bit is set]

- Fulfillment Error [Transaction Error bit is set]

Packets Occurred > 0 AND # Packets Occurred < MULT

- CRC Error [Transaction Error bit is set]

Note: For isochronous transfers, when a dTD is retired, the next dTD is primed for the next frame. For continuous (micro)frame to (micro)frame operation the DCD should ensure that the dTD linked-list is out ahead of the device controller by at least two (micro)frames.

Isochronous Pipe Synchronization

When it is necessary to synchronize an isochronous data pipe to the host, the (micro)frame number (read the FRINDEX register) can be used as a marker. To cause a packet transfer to occur at a specific (micro)frame number [N], the DCD should interrupt on SOF during frame N - 1. When the FRINDEX = N - 1, the DCD must write the prime bit. The device controller primes the isochronous endpoint in (micro)frame N - 1 so that the device controller executes delivery during (micro)frame N.

Caution: Priming an endpoint towards the end of (micro)frame N - 1 does not guarantee delivery in (micro)frame N. The delivery might actually occur in (micro)frame N+1 if device controller does not have enough time to complete the prime before the SOF for packet N is received.

Isochronous Endpoint Bus Response

Table 15-10: USB Device Isochronous Endpoint Bus Response

| Token Type | Stall Bit [TXS] | Endpoint Not Primed | Endpoint Primed | Buffer Underflow | Buffer Overflow | Endpoint Not Enabled |
|------------|-----------------|---------------------|-----------------|------------------|-----------------|----------------------|
| Setup | STALL | STALL | STALL | N/A | N/A | BTO |
| IN | NULL Packet | NULL Packet | Transmit | BS Error | N/A | BTO |
| OUT | Ignore | Ignore | Receive | N/A | Drop Packet | BTO |
| Ping | Ignore | Ignore | Ignore | Ignore | Ignore | BTO |
| Invalid | Ignore | Ignore | Ignore | Ignore | Ignore | BTO |

15.6.5 Control Endpoint Operational Model

All requests to a control endpoint begin with a setup phase followed by an optional data phase and a required status phase. The device controller always accepts the setup phase unless the setup lockout is engaged.

Lockout and Tripwire for Setup Packets

The setup lockout can be engage so that future setup packets from the host are ignored by the controller while the DCD retrieves the current setup packet. Lockout of setup packets ensures that while the DCD is reading the setup packet stored in the queue head data is not written as it is being read potentially causing an invalid setup packet.

The setup lockout mechanism can be disabled and a tripwire type semaphore will ensure that the setup packet payload is extracted from the queue head without being corrupted by an incoming setup packet. This is the preferred behavior because ignoring repeated setup packets due to long software interrupt latency would be a compliance issue.

The tripwire semaphore can ensure the proper addition of a new dTD to an active (primed) endpoint’s linked list. The add dTD tripwire bit, usb.USBCMD [ATDTW] can be set and cleared by software. This bit can be cleared by hardware when its state machine is in a hazard region for which adding a dTD to a primed endpoint may go unrecognized.

Setup Packet Handling using the Tripwire

Disable setup lockout by writing 1 to setup lockout mode, `usb.USBMODE [SLOM]` bit field; once at initialization. Setup lockout is not necessary when using the tripwire as described in the example below.

Example: Setup Packet Handling using the Tripwire

After receiving an interrupt and inspecting `usb.ENDPTSETUPSTAT` register to determine that a setup packet was received on a particular pipe (i.e., the dQH was written to memory by the hardware):

1. **Setup the Tripwire Mechanism:** Write 1 to `usb.USBCMD [SUTW]`.
2. **Read the Setup Buffer:** Copy the contents of `dQH.SetupBuffer` into local software byte array.
3. **Test to see if another Setup Packet was received.** Read the tripwire bit `[SUTW]` again.
 - a. If `[SUTW] = 1` (not received), then continue to [step 4](#) and process the setup buffer.
 - b. If `[SUTW] = 0` (another packet received), then go to [step 1](#) and copy that setup buffer, too.
4. **Clear the Interrupt:** Write 1 to clear corresponding `usb.ENDPTSETUPSTAT` register bit.

A poll loop should be used to wait until `usb.ENDPTSETUPSTAT` transitions to 0 and before priming for the status/handshake phases.

The time from writing a 1 to `usb.ENDPTSETUPSTAT` register and reading back a 0 is very short (approximately 1 to 2 microsecond) so a poll loop in the DCD should not be harmful in most systems.

5. **Clear the Tripwire:** Write 0 to clear setup tripwire bit `usb.USBCMD [SUTW]`.
6. **Process setup packet:** Use the local software byte array copy and execute status/handshake phases.
7. **Check Endpoint status:** Before priming for status/handshake phases, ensure that the `usb.ENDPTSETUPSTAT` bit is = 0.

Note: After receiving a new setup packet, the status and/or handshake phases might still be pending from a previous control sequence. These should be flushed and deallocated before linking a new status and/or handshake dTD for the most recent setup packet.

Data Phase

Following the setup phase, the DCD must create a device transfer descriptor for the data phase and prime the transfer.

After priming the packet, the DCD must verify a new setup packet has not been received by reading the `usb.ENDPTSETUPSTAT` register immediately verifying that the prime had completed. A prime completes when the associated bit in the `usb.ENDPTPRIME` register is 0 and the associated bit in the `usb.ENDPTSTATUS` register is a 1. If a prime fails, i.e., the `usb.ENDPTPRIME` bit goes to 0 and the `usb.ENDPTSTATUS` bit is not set, then the prime has failed. This can only be due to improper setup of the dQH, dTD or a setup arriving during the prime operation. If a new setup packet is indicated after the endpoint prime bit is cleared, then the transfer descriptor can be freed and the DCD must reinterpret the setup packet.

Should a setup arrive after the data stage is primed, the device controller automatically clears the prime status (usb.ENDPTSTATUS) to enforce data ordering with the setup packet.

Note: The dQH.Mult field must be set to 00 for bulk, interrupt, and control endpoints. Error handling of data phase packets is the same as bulk packets described previously.

Status Phase

Similar to the data phase, the DCD must create a transfer descriptor (with byte length equal 0) and prime the endpoint for the status phase. The DCD must also perform the same checks of the usb.ENDPTSETUPSTAT as described above in the data phase.

Note: The dQH.Mult bit field must be set to 00 for bulk, interrupt, and control endpoints. Error handling of data phase packets is the same as bulk packets described previously.

Control Endpoint Bus Response

The device controller response to packets on a control endpoint according to the device controller state is shown in Table 15-11. The normal operating mode is shaded.

Table 15-11: USB Device Control Endpoint Bus Response

| Packet Identifier | Stall Bit [TXS] | Endpoint Not Primed | Endpoint Primed | Buffer Underflow | Buffer Overflow | Endpoint Not Enabled | Setup Lockout |
|-------------------|-----------------|---------------------|---------------------------|------------------|-----------------|----------------------|---------------|
| Setup | ACK | ACK | ACK | N/A | SYSERR | BTO | |
| IN | STALL | NAK | Transmit | BS Error | N/A | BTO | N/A |
| OUT | STALL | NAK | Receive and then NYET/ACK | N/A | NAK | BTO | N/A |
| Ping | STALL | NAK | ACK | N/A | N/A | BTO | N/A |
| Invalid | Ignore | Ignore | Ignore | Ignore | Ignore | BTO | Ignore |

Notes:

1. BS Error — Force Bit Stuff Error.
2. NYET/ACK — NYET unless the Transfer Descriptor has packets remaining according to the USB variable length protocol then ACK.
3. SYSERR — System error should never occur when the latency FIFOs are correctly sized and the DCD is responsive.
4. BTO — Bus Time Out.

15.7 Device Endpoint Descriptor Reference

This section contains the definitions of the endpoint descriptors for the device controller. There usages are described in other chapter sections, including section 15.5.1 Link-list Endpoint Descriptors.

- 15.7.1 Endpoint Queue Head Descriptor (dQH)
- 15.7.2 Endpoint Transfer Descriptor (dTD)

- 15.7.3 Endpoint Transfer Overlay Area

15.7.1 Endpoint Queue Head Descriptor (dQH)

The device Endpoint Queue Head (dQH) is where all device controller transfers are managed. The dQH is a 48-byte data structure, but must be aligned on 64-byte boundaries. During priming of an endpoint, the hardware reads the dQH and the first device transfer descriptor (dTD) from system memory and overlays it onto DWords 2 through 8 of the dQH as shown in Table 15-12.

Table 15-12: USB Device Queue Head (dQH) Descriptor Format

| Reference | Type | 31 | 30 | 29 | 28 | 27 | 26 | 25 | 24 | 23 | 22 | 21 | 20 | 19 | 18 | 17 | 16 | 15 | 14 | 13 | 12 | 11 | 10 | 9 | 8 | 7 | 6 | 5 | 4 | 3 | 2 | 1 | 0 | DWord |
|-------------|-----------------------|-------------------------|-------------|-----|----|----|-----------------------|----|----|----|----|----|-----|--------|-------|----|-----|----------------|----|----|----|----|----|---|---|---|---|---|---|---|---|---|---|-------|
| Table 15-13 | | Mult | | ZLT | 0 | | Maximum Packet Length | | | | | | | | | | IOS | | 0 | | | | | | | | | | 0 | | | | | |
| | Current Pointer | Current dTD Pointer | | | | | | | | | | | | | | | | 0 | | | | | | | | | | 1 | | | | | | |
| Table 15-15 | Transfer Overlay Area | Next dTD Pointer | | | | | | | | | | | | | | | | 0000 | | | | | | | | | | T | 2 | | | | | |
| | | 0 | Total Bytes | | | | | | | | | | IOC | C_Page | MultO | 0 | | Status | | | | | | | | | | 3 | | | | | | |
| | | Buffer Pointer (Page 0) | | | | | | | | | | | | | | | | Current Offset | | | | | | | | | | 4 | | | | | | |
| | | Buffer Pointer (Page 1) | | | | | | | | | | | | | | | | reserved | | | | | | | | | | 5 | | | | | | |
| | | Buffer Pointer (Page 2) | | | | | | | | | | | | | | | | reserved | | | | | | | | | | 6 | | | | | | |
| | | Buffer Pointer (Page 3) | | | | | | | | | | | | | | | | reserved | | | | | | | | | | 7 | | | | | | |
| | | Buffer Pointer (Page 4) | | | | | | | | | | | | | | | | reserved | | | | | | | | | | 8 | | | | | | |
| Table 15-13 | | reserved | | | | | | | | | | | | | | | | 9 | | | | | | | | | | | | | | | | |
| | | Setup Buffer Bytes 3..0 | | | | | | | | | | | | | | | | 10 | | | | | | | | | | | | | | | | |
| | | Setup Buffer Bytes 7..4 | | | | | | | | | | | | | | | | 11 | | | | | | | | | | | | | | | | |

Device Controller Read/Write Device Controller Read-only

Table 15-13: USB Device dQH DWords 0 to 11: Descriptor Bit Details

| Bits | Description |
|---|---|
| DWord 0: Endpoint Capabilities/Characteristics | |
| 31:30 | High-Bandwidth Pipe Multiplier, Mult . This field is used to indicate the number of packets executed per transaction description as given by the following: <ul style="list-style-type: none"> 00: Execute N Transactions as demonstrated by the USB variable length packet protocol where N is computed using the Maximum Packet Length (dQH) and the Total Bytes field (dTD). 01: Execute 1 Transaction. 10: Execute 2 Transactions. 11: Execute 3 Transactions. Non-Isochronous endpoints: must set Mult = 00. Isochronous endpoints: must set Mult = 01, 10, or 11 as needed. |
| 29 | Zero Length Termination Select, ZLT . This bit is used to indicate when a zero length packet is used to terminate transfers where the total transfer length is a multiple. This bit is not relevant for Isochronous. <ul style="list-style-type: none"> 0: Enable zero length packet to terminate transfers equal to a multiple of the Maximum Packet Length. 1: Disable the zero length packet on transfers that are equal in length to a multiple Maximum Packet Length. |
| 28:27 | Reserved. Field reserved and should be set to 0. |
| 26:16 | Maximum Packet Length . This directly corresponds to the maximum packet size of the associated endpoint (wMaxPacketSize). The maximum value this field can contain is 400h (1,024). |

Table 15-13: USB Device dQH DWords 0 to 11: Descriptor Bit Details (Cont'd)

| Bits | Description |
|---|---|
| 15 | Interrupt On Setup, IOS . This bit is used on control type endpoints to indicate if USBINT is set in response to a setup being received. |
| 14:0 | Reserved. Field reserved and should be set to 0. |
| DWord 1: Current dTD Pointer | |
| 31:5 | Current dTD Pointer. Pointer to the dTD that is represented in the transfer overlay area. This field will be modified by the Device Controller to next dTD pointer during endpoint priming or queue advance. The current dTD pointer is used by the device controller to locate the transfer in progress. This word is for the Device Controller hardware's use only and should not be modified by the DCD. |
| 4:0 | Reserved. Field reserved and should be set to 0. |
| DWords 2 to 8: Overlay Area , refer to Table 15-15 USB Device Transfer Overlay . | |
| DWord 9: reserved. | |
| DWord 10: Setup Buffer Bytes 3:0 | |
| 31:24 | Byte 3 |
| 24:16 | Byte 2 |
| 15:8 | Byte 1 |
| 7:0 | Byte 0 |

15.7.2 Endpoint Transfer Descriptor (dTD)

The dTD describes to the device controller the location and quantity of data to be sent/received for given transfer. The DCD should not attempt to modify any field in an active dTD except the Next dTD Pointer.

The dTD descriptors are illustrated in [Table 15-14](#). The fields are detailed in [Table 15-8](#) and described in section [15.7.3 Endpoint Transfer Overlay Area](#).

Table 15-14: USB Device Transfer Descriptor (dTD) Format

| Reference | Type | 31 | 30 | 29 | 28 | 27 | 26 | 25 | 24 | 23 | 22 | 21 | 20 | 19 | 18 | 17 | 16 | 15 | 14 | 13 | 12 | 11 | 10 | 9 | 8 | 7 | 6 | 5 | 4 | 3 | 2 | 1 | 0 | DWord |
|-------------|-----------------------|-------------------------|-------------|----|----|----|----|----|----|----|----|----|-----|--------|----------------|--------------|--------|----|----|----|----|----|----|---|---|---|---|------|---|---|---|---|---|-------|
| Table 15-15 | Transfer Overlay Area | Next dTD Pointer | | | | | | | | | | | | | | | | | | | | | | | | | | 0000 | T | 0 | | | | |
| | | 0 | Total Bytes | | | | | | | | | | ioc | C_Page | MultO | 0 | Status | | | | | | | | | | | 1 | | | | | | |
| | | Buffer Pointer (Page 0) | | | | | | | | | | | | | Current Offset | | | | | | | | | | | | | 2 | | | | | | |
| | | Buffer Pointer (Page 1) | | | | | | | | | | | | | R | Frame Number | | | | | | | | | | | | | 3 | | | | | |
| | | Buffer Pointer (Page 2) | | | | | | | | | | | | | reserved | | | | | | | | | | | | | 4 | | | | | | |
| | | Buffer Pointer (Page 3) | | | | | | | | | | | | | reserved | | | | | | | | | | | | | 5 | | | | | | |
| | | Buffer Pointer (Page 4) | | | | | | | | | | | | | reserved | | | | | | | | | | | | | 6 | | | | | | |

Device Controller Read/Write
 Device Controller Read-only

15.7.3 Endpoint Transfer Overlay Area

The dQH is read from memory by the controller and links to a dTD. The dTD is also read from memory and is written into the overlay area of the dQH as shown in [Table 15-15](#).

The seven DWords in the overlay area represent a transaction working space for the device controller. After an endpoint is readied, the dTD will be copied into this dQH overlay area by the device controller. Until a transfer is expired, the DCD must not write the queue head overlay area or the associated transfer descriptor. When the transfer is complete, the device controller will write the dTD back to system memory (with transfer status results added) and advance the queue pointer.

If the link list continues, then another dTD is fetched from memory and written into the transfer overlay area of the dQH. After the link list is processed, the dQH is written back to system memory and the endpoint servicing is completed.

The Overlay Transaction dQH DWords 2 through 8 are nearly identical to the dTD DWords 0 through 6 as shown in [Table 15-15](#).

Transfer Overlay Table

The transfer overlay DWords that are used in both dQH and dTD descriptors are listed in [Table 15-15 USB Device Transfer Overlay](#). The descriptions for Total Bytes and Multiplier Override fields are described in the beginning of this section.

Table 15-15: USB Device Transfer Overlay

| Bits | Description | dTD DWord | dQH DWord |
|--|---|-----------|-----------|
| Next dTD Pointer and Terminate. | | 0 | 2 |
| 31:5 | Next Transfer Element Pointer, Next dTD Pointer . System memory address [31:5] of the next dTD to be processed. | | |
| 4:1 | Reserved. Field reserved and should be set to 0. | | |
| 0 | Terminate transfer, T . <ul style="list-style-type: none"> • 0: link to the Next dTD Pointer field; the address is valid. • 1: end the transaction, the Next dTD Pointer field is not valid. | | |

Table 15-15: USB Device Transfer Overlay (Cont'd)

| Bits | Description | dTD DWord | dQH DWord |
|---|--|---------------|---------------|
| Total Bytes, MultO, and Status. | | | |
| 31 | Reserved. Field reserved and should be set to 0. | 1 | 3 |
| 30:16 | Total Bytes. Total number of bytes to be moved with this transfer descriptor. Refer to section Total Bytes to Transfer Parameter for more info. | | |
| 15 | Interrupt On Complete, IOC . Indicates if USBINT is to be set in response to device controller being finished with this dTD. | | |
| 14:12 | Current Page, C_Page . Reserved in Device mode. | | |
| 11:10 | Multiplier Override, MultO . Used for transmit isochronous packets, refer to text. | | |
| 9:8 | Reserved. Field reserved and should be set to 0. | | |
| 7:0 | Status. This field is used by the device controller to communicate individual command execution status back to the DCD. This field contains the status of the last transaction performed on this dTD. Bit [7] Active Status . Bit [6] Halted Status . Bit [5] Data Buffer Error Status . Bit [3] Transaction Error Status . Other bits: reserved. | | |
| Buffer Pointer Page 0 and Current Offset | | | |
| 31:12 | Buffer Pointer. 4KB aligned pointer to system memory address bits [31:12]. | 2 | 4 |
| 11:0 | Current Offset. | | |
| Frame Number and Buffer Pointer Page 1 | | | |
| 31:12 | Buffer Pointer. 4KB aligned pointer to system memory address bits [31:12]. | 3 | 5 |
| 11 | Reserved, R . Field reserved and should be set to 0. | | |
| 10:0 | Frame Number. Written by the device controller to indicate the frame number in which a packet finishes. This is typically used to correlate relative completion times of packets on an iso endpoint. | | |
| Buffer Pointer Pages 2 to 4 | | | |
| 31:12 | Buffer Pointer. 4KB aligned pointer to system memory address bits [31:12]. | 4 to 6 | 6 to 8 |
| 11:0 | Reserved. Field reserved and should be set to 0. | | |

Multiplier Override (MultO) Bit Field

The total bytes field is used for both dQH and dTD descriptors and is also used for transmit iso IN endpoints to override the multiplier in the dQH. This field must be 0 for all packet types that are not transmit (IN) iso endpoints. For maximal efficiency, the DCD should compute $MultO = \text{greatest integer of } (\text{Total Bytes} / \text{Max. Packet Size})$ except for the case when Total Bytes = 0; then MultO should be set = 1.

Example 1: Send three packets

- If dQH.multiplier = 3; Max packet size = 8; Total Bytes = 15; dQH.Mult = 0 (default), **then** three packets are sent: Data2 (8) + Data1 (7) + Data0 (0).

Example 2: Send two packets

- If `dQH.multiplier = 3`; Max packet size = 8; Total Bytes = 15; `dQH.Mult = 2`, then two packets are sent: Data1 (8) +Data0 (7).

Buffer Pointer Pages

The buffer pointers are aligned to 4KB boundaries. The total bytes and buffer pointers are discussed in section [Total Bytes to Transfer Parameter](#).

Total Bytes to Transfer Parameter

The Total Bytes bit field specifies the total number of bytes to be moved with the transfer descriptor. This field is decremented by the number of bytes actually moved during the transaction and only on the successful completion of the transaction. This bit field applies to:

- qTD for host mode, refer to section [15.12.5 Queue Element Transfer Descriptor \(qTD\)](#).
- dTD for device mode, refer to section [15.7.2 Endpoint Transfer Descriptor \(dTD\)](#).

The maximum value that the DCD may store in the field is 5 times 4 KB (5000h). This is the maximum number of bytes that 5 page pointers can reference. Although it is possible to create a transfer up to 20 KB this assumes the 1st offset into the first page is 0. When the offset cannot be predetermined, crossing past the 5th page can be guaranteed by limiting the total bytes to 16 KB. Therefore, the maximum recommended transfer is 16 KB (4000h).

Device Mode Note

If the value of the Total Bytes bit field is 0 when the device controller fetches this transfer descriptor (and the active bit is set), the reaction of the device controller depends on the setting of the `dQH.ZLT` bit. Refer to section [15.6.3 Interrupt and Bulk Endpoint Operational Model](#).

- It is not a requirement for that Total Bytes To Transfer be an even multiple of Maximum Packet Length. If the DCD builds such a transfer descriptor for a transfer, the last transaction will always be less than Maximum Packet Length.

15.8 Programming Guide for Device Controller

The function of the device controller is to transfer a request in the memory image to and from the USB. The device controller programs and primes the endpoints based on the application protocol. The controller executes a set of linked list transfer descriptors, pointed to by a queue head that the device controller executes to perform the requested data transfers. The following sections explain the use of the device controller from the DCD point-of-view and further describe how specific USB bus events relate to status changes in the device controller's registers.

15.8.1 Software Model

The USB device controller API software provides a framework of routines to control the USB controller in device applications. The software should be designed to significantly simplify the software tasks required to develop a USB device application. The API software presents a high-level data transfer interface to the user's application code. All the register, interrupt and DMA interactions with the controller are managed by the API. The API also includes routines that handle all the USB device framework commands which are required for all USB devices.

15.8.2 USB Reset

After receiving a USB reset from the bus, the port enters the default FS or default HS state in accordance with the reset protocol described in Appendix C.2 of the USB Specification Rev. 2.0. The state diagram shown in [Figure 15-12](#) depicts the state of the controller in device mode.

15.8.3 Register Controlled Reset

To reset the controller, the DCD writes a 1 to the `usb.USBCMD [RST]` bit. When the reset process is completed, the controller hardware sets this bit to 0. Once the reset is started, the controller cannot stop the process. Writing a 0 has no effect.

Writing a 1 to the [RST] bit will reset the internal pipelines, timers, counters, and state machines to their initial value. Writing a 1 when the device is in the attached state is not recommended since the effects on an attached host are undefined. In order to ensure that the device is not in an attached state, all primed endpoints should be flushed and the `usb.USBCMD [RS]` bit should be set to 0.

15.9 Programming Guide for Device Endpoint Data Structures

This section describes how to manage the device endpoint data structures. These are images written in system memory that are accessed by the controller to service USB transaction initiated by the host. These structures are the basis for the device controller functions.

15.9.1 Device Controller Initialization Overview

After hardware reset, the device is disabled until the Run/Stop bit is set to a 1. In the disabled state, the pull-up on the USB D+ is not active which prevents an attach event from occurring. At a minimum, it is necessary to have the queue heads setup for endpoint 0 before the device attach occurs. Shortly after the device is enabled, a USB reset occurs followed by setup packet arriving at endpoint 0. A Queue head must be prepared so that the device controller can store the incoming setup packet.

In order to initialize a device, the DCD should perform the following steps:

1. **Set the controller to device mode.** Write 10 to the usb.USBMODE [CM] bit.
 - Transitioning from host mode to device mode requires a device controller reset before modifying USBMODE.
 - Set usb.OTGSC [OT] bit = 1.
2. **Allocate and initialize dQH's.**
 - Minimum: Initialize dQH's for endpoint 0 for Tx and Rx.
 - All control endpoint queue heads must be initialized before the control endpoint is enabled. Non-control queue heads must be initialized before the endpoint is used and not necessarily before the endpoint is enabled.
 - For information on device queue heads, refer to section [15.7.1 Endpoint Queue Head Descriptor \(dQH\)](#).
3. **Configure the Endpoint List Address.** Write the memory address for the Queue Head endpoint list into the usb._ENDPOINTLISTADDR [31:11] bit field.
4. **Enable the software interrupt.**
 - Enable IRQ interrupt signal in GIC (ID#53 for USB 0 and ID#76 for USB 1).
 - Enable device interrupts in the usb.USBINTR register:
 - USB interrupt [UI]
 - USB Error Interrupt [UEI]
 - Port change detect [PCI]
 - USB Reset received [URI]
 - DCSuspend [SLI]
 - For a list of available interrupts refer to [Table 15-2 USB Interrupt and Status Register Bits](#).
5. **Enable Run mode.** Set Run/Stop bit to Run Mode.
 - After the run bit is set, a device USB reset occurs. The DCD must monitor the reset event and adjust the DCD state as described in the Bus Reset section of the following Port State and Control section below.
 - Endpoint 0 is designed as a control endpoint only and does not need to be configured using ENDPTCTRL0 register.
 - It is also not necessary to initially prime Endpoint 0 because the first packet received will always be a setup packet. The contents of the first setup packet will require a response in accordance with USB device framework (Chapter 9) command set.

15.9.2 Manage Transfer Descriptors

The function of the endpoint is to instruct the DMA engine to move data between system memory and the Tx and Rx FIFOs. Each endpoint has two data structures: one for IN and the other for OUT data transfers. The device mode data structures include a device Queue Head (dQH) and one or more device Transfer Descriptors (dTD). The dQH defines the type of data transfer and points to the first dTD. The dTD includes a system address pointer to the memory buffer(s) where data is either stored or read from.

The dQH's are indexed (two for each endpoint) in the 24-element Endpoint Queue Head List. To setup a transfer, software constructs the dQH and dTD(s) for an IN or OUT operation. Software must maintain a consistent set of descriptors, schedules/lists, and data buffers in system memory for the controller. When the endpoint is ready to receive or send the data, software primes the endpoint.

When an endpoint is primed, the device controller reads the associated dQH and dTD into the controller's dual-port RAM for easy access by the DMA and protocol engines. When the DMA for a dTD is done, the controller writes the dTD back to system memory with transfer results (status). If the terminate bit, $T = 0$ (do not terminate) then the controller fetches and processes the next dTD from system memory. If $T = 1$, then the controller stops processing the endpoint dQH and writes the dQH back to system memory. In a long link-list the controller will repeatedly cause the controller to read and write dTD's between system memory the controller's dual-port RAM.

Example: Initialize dQH

One pair of device queue heads must be initialized before an endpoint is primed to respond to the host. To initialize a device queue head (dQH):

1. Write the `wMaxPacketSize` field as required by the USB specification Chapter 9 or application specific protocol.
2. Write the multiplier field to 0 for control, bulk, and interrupt endpoints. For IsoUSB endpoints, set the multiplier to 1, 2, or 3 as required bandwidth and in conjunction with the USB Chapter 9 protocol. Note: In FS mode, the multiplier field can only be 1 for IsoUSB endpoints.
3. To terminate the Transfer: Set $T = 1$ in the Terminate bit of the next dTD.
4. Write the Active bit in the status field to 0.
5. Write the Halt bit in the status field to 0.

Note: The DCD must only modify dQH if the associated endpoint is not primed and there are no outstanding dTD's.

Example: Operational Model for Setup Transfers

As discussed in [15.6.5 Control Endpoint Operational Model](#), setup transfer requires special treatment by the DCD. A setup transfer does not use a dTD but instead stores the incoming data from a setup packet in an 8-byte buffer within the dQH.

1. Copy setup buffer contents from dQH - Rx to software buffer.
2. Acknowledge setup packet by writing a 1 to the corresponding bit in `usb.ENDPTSETUPSTAT`.
 - a. The acknowledge must occur before continuing to process the setup packet.
 - b. After the acknowledge has occurred, the DCD must not attempt to access the setup buffer in the dQH - Rx. Only the local software copy should be examined.
3. Check for pending data or status dTD's from previous control transfers and flush if any exist as discussed in section [Flushing/De-priming an Endpoint](#).
 - a. It is possible for the device controller to receive setup packets before previous control transfers complete. Existing control packets in progress must be flushed and the new control packet completed.

1. Decode setup packet and prepare data phase (optional) and status phase transfer as required by the USB Chapter 9 or application specific protocol.

15.9.3 Manage Transfers with Transfer Descriptors

Example: Build a Transfer Descriptor

Before a transfer can be executed, a dTD must be built to describe the transfer. Use the following procedure for building dTD's. To hold the 8-DWord dTD in memory, allocate a 32-Byte block of system memory aligned to a 32-Byte boundary (address [4:0] = 00000).

Write the following fields:

1. Initialize first 7 DWords. Write 0 all bits in all DWords.
2. Program the Terminate Bit. If only one dTD or its the last dTD, set the terminate bit to 1.
3. Fill in total bytes with transfer size.
4. Set the interrupt on complete if desired.
5. Initialize the status field with the active bit set to 1 and all remaining status bits set to 0.
6. Fill in buffer pointer page 0 and the current offset to point to the start of the data buffer.
7. Initialize buffer pointer page 1 through page 4 to be one greater than each of the previous buffer pointer.

Example: Execute a Transfer Descriptor

To safely add a dTD, the DCD must be follow this procedure which will handle the event where the device controller reaches the end of the dTD list at the same time a new dTD is being added to the end of the list.

Determine whether the link list is empty: Check to see if pipe is empty (internal software representation of linked-list should indicate if any packets are outstanding).

Case 1: Link list is empty

1. Write dQH next pointer and the dQH terminate bit to 0 as a single DWord operation.
2. Clear active and halt bit in dQH (in case set from a previous error).
3. Prime endpoint by writing 1 to correct bit position in usb.ENDPTPRIME.

Case 2: Link list is not empty

1. Add dTD to end of linked list.
2. Read correct prime bit in usb.ENDPTPRIME - if 1 DONE.
3. Set the usb.USBCMD [ATDTW] bit = 1.
4. Read correct status bit in usb.ENDPTSTAT. (store in tmp. variable for later)
5. Read usb.USBCMD [ATDTW] bit.

If 0 go to [step 3](#).
 If 1 continue to [step 6](#).

6. Write usb.USBCMD [ATDTW] bit = 0.
7. If status bit read in (4) is 1 DONE.
8. If status bit read in (4) is 0 then Goto Case 1: [step 1](#).

Transfer Completion

After a dTD has been initialized and the associated endpoint primed the device controller will execute the transfer upon the host-initiated request. The DCD will be notified with a USB interrupt if the interrupt on complete bit was set or alternately, the DCD can poll the endpoint complete register to find when the dTD had been executed. After a dTD has been executed, the DCD can check the status bits to determine success or failure.

Caution: Multiple dTD can be completed in a single endpoint complete notification. After clearing the notification, the DCD must search the dTD linked list and retire all dTD's that have finished (Active bit cleared).

By reading the status fields of the completed dTD's, the DCD can determine if the transfers completed successfully. Success is determined with the following combination of status bits:

```
Active = 0
Halted = 0
Transaction Error = 0
Data Buffer Error = 0
```

Should any combination other than the one shown above exist, the DCD must take proper action. Transfer failure mechanisms are indicated in the device error matrix.

In addition to checking the status bit, the DCD must read the Transfer Bytes field to determine the actual bytes transferred. When a transfer is complete, the Total Bytes transferred is decremented by the actual bytes transferred. For Transmit packets, a packet is only complete after the actual bytes reach 0, but for receive packets, the host might send fewer bytes in the transfer according the USB variable length packet protocol.

Example: Flushing/De-priming an Endpoint

It is necessary for the DCD to use the flush bit(s) to de-prime one or more endpoints when a USB device reset is received or when a broken control transfer occurs. There can also be application specific requirements to stop transfers in progress. The following procedure can be used by the DCD to stop a transfer in progress and ensure the transfer has stopped:

1. Write a 1 to the corresponding bit(s) in usb.ENDPTFLUSH.
2. Wait until all bits in usb.ENDPTFLUSH are 0.

Software interrupt routine note: This operation can take a large amount of time depending on the USB bus activity. It is not desirable to have this wait loop within an interrupt service routine.

3. Read usb.ENDPTSTAT to ensure that for all endpoints commanded to be flushed, that the corresponding bits are now 0. If the corresponding bits are 1 after step #2 has finished, then the

flush failed: in very rare cases, a packet is in progress to the particular endpoint when commanded flush using `usb.ENDPTFLUSH`. A safeguard is in place to refuse the flush to ensure that the packet in progress completes successfully. The DCD might need to repeatedly flush any endpoints that fail to flush by repeating steps 1–3 until each endpoint is successfully flushed.

Note: A time out counter can be programmed to recover from when an endpoint flush fails.

Device Errors

Table 15-16 summarizes packet errors that are not automatically handled by the device controller.

Table 15-16: USB Device Errors

| Error | Direction | Packet Type | Data Buffer Error Bit (dTD.Status bit 5) | Transaction Error Bit (dTD.Status bit 3) | Description |
|-------------------------|-----------|-------------|--|--|---|
| Overflow | Rx | Any | 1 | 0 | Number of bytes received exceeded max. packet size or total buffer length. This error will also set the Halt bit in the dQH and if there are dTD's remaining in the linked list for the endpoint, then those will not be executed. |
| Isochronous Packet | Rx | Iso | 0 | 1 | CRC Error on received isochronous packet. Contents not guaranteed to be correct. |
| Isochronous Fulfillment | Both | Iso | 0 | 1 | Host failed to complete the number of packets defined in the dQH.Mult field within the given (micro)frame. For scheduled data delivery the DCD might need to readjust the data queue because a fulfillment error will cause Device Controller to cease data transfers on the pipe for one (micro)frame. During the "dead" (micro)frame, the Device Controller reports error on the pipe and primes for the following frame. |

Notice that the device controller handles all errors on Bulk/Control/Interrupt Endpoints except for a data buffer overflow. However, for IsoUSB endpoints, errors packets are not retried and errors are tagged as indicated.

15.9.4 Service Device Mode Interrupts

Note: The interrupt service routine must consider that there are high-frequency, low-frequency operations, and error interrupts. It is likely that multiple interrupts will stack up on a call to the Interrupt Service Routine (ISR) and then during the execution of the interrupt service routine.

The interrupt handling strategy is up to the user. The ISR can poll the high-frequency and then low-frequency interrupts before exiting. If another interrupt is detected and processed, then the ISR would perform another 'last scan' of the interrupts before exiting.

High-Frequency Interrupts

High frequency interrupts, in particular, should be handed in the order shown in Table 15-17. The most important of these are the first two, 1a and 1b. They have equal priority because the software

must acknowledge a setup token in the timeliest manner possible to have the control endpoint and buffer always available for another Setup token. The SOF interrupt is next important.

Table 15-17: USB Device High Frequency Interrupt

| Execution Order | Interrupt | usb.USBSTS | Action |
|-----------------|-----------------------------------|------------|---|
| 1a | USB Interrupt ENDPTSETUPSTATUS | [UI] | Copy contents of setup buffer and acknowledge setup packet. Process setup packet according to USB 2.0 Chapter 9 or application specific protocol. |
| 1b | USB Interrupt ENDPTCOMPLETE | [UI] | Handle completion of dTD. |
| 2 | SOF Interrupt | [SRI] | Action as deemed necessary by application. This interrupt might not have a use in all applications. |

Low-Frequency Interrupts

The low frequency events include the following interrupts. These interrupt can be handled in any order since they do not occur often in comparison to the high-frequency interrupts.

Table 15-18: USB Low-Frequency Interrupt

| Interrupt | usb.USBSTS | Action |
|----------------|------------|---|
| Port Change | [PCI] | Change the software state information. |
| Suspend | [SLI] | Change the software state information. |
| Reset Received | [URI] | Change the software state information. Abort pending transfers. |

Error Interrupts

Error interrupts will be least frequent and should be placed last in the interrupt service routine.

Table 15-19: USB Device Error Interrupt

| Interrupt | usb.USBSTS | Action |
|--------------|------------|---|
| USB Error | [UEI] | This error is redundant because it combines USB Interrupt and an error status in the dTD. The DCD will more aptly handle packet-level errors by checking dTD status field upon receipt of USB Interrupt (with ENDPTCOMPLETE). |
| System Error | [SEI] | Unrecoverable error. Immediate Reset of controller, free transfers buffers in progress and restart the software. |

15.10 Host Mode Data Structures

The programming model follows the EHCI specification model and includes additional registers and bits to support a virtual transaction translator that is embedded into the DMA and protocol engines of the high speed host controller.

The Rx and Tx data FIFOs must respond to the USB in real-time. Packet sizes can be up to 1024 bytes. The transfer descriptors must have memory bandwidth for accessing descriptors and DMA to/from the FIFOs.

The embedded transaction translator uses QH and qTD descriptors for interrupt endpoints and siTD's for isochronous endpoints.

The host controller is a schedule driven environment of periodic (interrupt / isochronous) and asynchronous (control / bulk) data transfers.

EHCI Enhancements and Deviations

These are listed in section [15.11 EHCI Implementation](#).

Transfer Schedules

The structures of the Transfer Schedules are defined in the EHCI specification.

Suspend and Resume

The programming model for suspend and resume is defined in the EHCI specification.

15.10.1 Host Controller Transfer Schedule Structures

The host controller uses two types of schedules to communicate control, status, and data between the HCD and the EHCI-compatible host controller in support of USB functions: periodic and asynchronous. The HCD writes the data structures for these schedules in to system memory (32-bit address space) and the controller hardware reads and modifies these structures as it executes the transaction schedules.

The periodic schedule includes the periodic frame list which is the root of all periodic (isochronous and interrupt transfer type) transfers, refer to section [15.10.2 Periodic Schedule](#).

The asynchronous schedule includes the bulk and control queue heads list which is a circular set of pointers which are at the root of all the bulk and control transfer types, refer to section [15.10.3 Asynchronous Schedule](#).

The host controller uses different types of descriptors for the periodic and asynchronous schedules in support of the Isochronous, Interrupt, Control and Bulk transfers as described in section [15.12.1 Descriptor Usage](#).

- Isochronous data streams are managed using isochronous transaction descriptors (iTd).

- Isochronous split transaction data streams are managed with split-transaction isochronous transfer descriptors (siTD).
- Interrupt, Control, and Bulk data streams are managed via queue heads (QH) and queue element transfer descriptors (qTD). These data structures are optimized to reduce the total memory footprint of the schedule and to reduce (on average) the number of memory accesses needed to execute a USB transaction.

15.10.2 Periodic Schedule

The periodic schedule provides interrupt and isochronous transfers by using the Periodic Frame list of elements and transfer descriptors as shown in Figure 15-15.

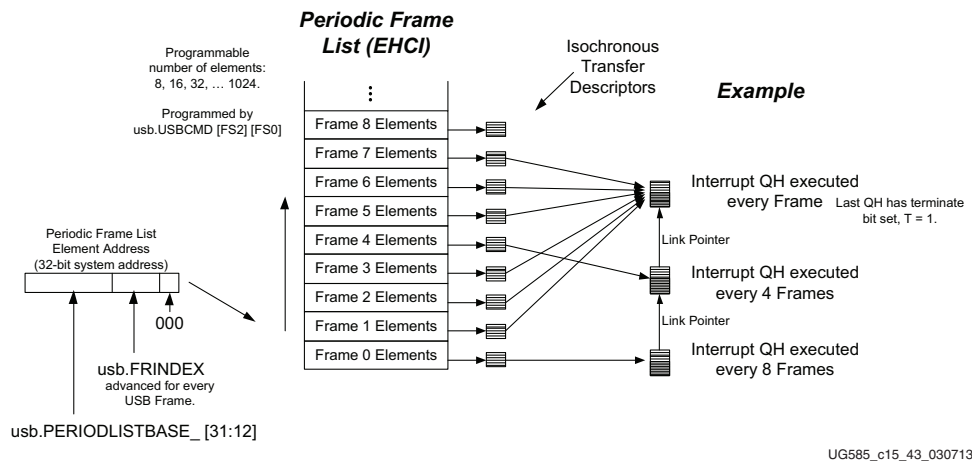

Figure 15-15: USB Host Periodic Schedule with Example

Periodic Frame List

The host controller uses the Periodic Frame List to schedule isochronous and interrupt transfers. The periodic frame list is written into memory by the HCD. The host controller hardware reads the elements using the `usb.PERIODICLISTBASE_` base address and the `FRINDEX` index registers. The current element within the periodic frame list is pointed to by the `FRINDEX` register. The Periodic Frame List implements a sliding window of work over time.

Note: The periodic frame list is a 4 KB page-aligned array for pointers to Isochronous and interrupt transfer descriptors. The length of the frame list is programmable: 8, 16, 32, 64, 128, 256, 512, or 1024 elements using the `usb.USBCMD [FS2]` and `[FS0]` bit fields. When `[FS2]` is set = 0, then the EHCI programming model: 256, 512 and 1024 elements can be used in `[FS0]`. The length of the frame list affects the amount of system memory to allocate and the number of periodic transactions that can be queued.

The HCD writes the memory address of the first element in the periodic frame list in the `usb.PERIODICLISTBASE_ [PERBASE_]` bit field. The controller begins processing the periodic frame list when the (micro)frame time stamp occurs.

Table 15-20: USB Host Periodic Frame List Element Bit Fields

| Bits | Bit Field | Description |
|------|-----------|---|
| 31:5 | Pointer | Frame List Link Pointer (system memory pointer, 32-byte aligned): The referenced object might be: <ul style="list-style-type: none"> • an isochronous transfer descriptor (iTID for HS devices), • a split-transaction isochronous transfer descriptor (siTD for FS isochronous endpoints), or • a queue head (QH for FS/LS/HS interrupts). |
| 4:3 | reserved | Set = 00. |
| 2:1 | TYP | Transaction Descriptor Type, TYP . Refer to section 15.12.2 Transfer Descriptor Type (TYP) Field . |
| 0 | T | Terminate Linking, T : 0: Continue linking using Frame List Link Pointer. 1: Terminate transaction (done), host controller ignores the link pointer. |

Note: The HCD should write only periodic schedule items (QH, iTD, siTD, FSTN) into the periodic schedule. When using QH, it is an interrupt endpoint.

15.10.3 Asynchronous Schedule

The asynchronous schedule includes a circular list of queue heads for control and bulk transfers. The host controller executes the data transfers after the periodic schedule is handled. This happens:

- after the controller processes the periodic list
- the periodic list is disabled, or
- the periodic list is empty.

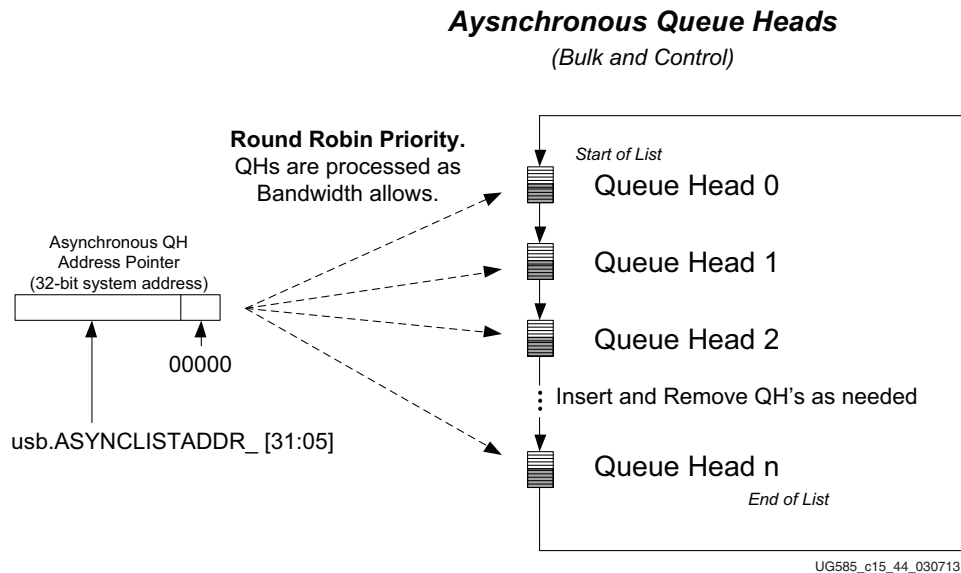

Figure 15-16: USB Host Controller Asynchronous Schedule Organization

The asynchronous list is a simple circular list of queue heads that are aligned on 32-byte address boundaries. The `usb.ASYNCLISTADDR_ [31:5]` bit field is a pointer to the next queue head. This bit field is initialized by software. Hardware uses this field to traverse the Asynchronous schedule. Hardware does not modify this field. The Asynchronous schedule implements a pure round-robin service for the queue heads. Each queue head has one or more transfer descriptors (qTD's). The number of queue heads in the circular can be added to and reduced. The number of QH's is not limited by the EHCI specification.

15.11 EHCI Implementation

The host controller utilizes the programming mode of the Intel EHCI 1.0 specification. This includes register models and host functionality.

15.11.1 Overview

The host controller operational mode is nearly compatible with the EHCI 1.0 specification. There are a few differences and enhancements to handle an FS/LS link:

- Embedded Transaction Translator
- EHCI Reserved Bits
- No PCI registers
- SOF Interrupt

Embedded Transaction Translator

The host controller uses the DMA and protocol engines to emulate the transaction translator (TT) for FS/LS devices attached to Zynq. The *embedded* transaction translator (TT) affects multiple functions in the host controller:

- Discovery Mechanism, refer to section [15.11.3 EHCI Functional Changes for the TT](#)
- FS/LS Data Structures, refer to section [15.11.6 FS/LS Data Structures](#)
- Operational Model of the TT, refer to section [15.11.7 Operational Model of the TT](#)
- Capability and Operational registers/bits, refer to section [15.11.3 EHCI Functional Changes for the TT](#)
- PHY Rx Commands, refer to section [15.11.3 EHCI Functional Changes for the TT](#)

The embedded transaction translator is described in section [15.11.2 Embedded Transaction Translator](#).

EHCI Reserved Bits

EHCI reserved fields should be set to zero, except those that are assigned to other functions. The register set is summarized in section [15.3.4 Register Overview](#) and detailed in Appendix B.

No PCI Bus Registers

This controller does not have a PCI Interface and the PCI configuration registers described in the EHCI specification are not applicable (e.g., the frame adjustment register is not supported; the starts of the microframes are timed by the controllers timers to deliver 125-microsecond intervals based on the 60 MHz clock from the ULPI PHY).

SOF Interrupt

This SOF Interrupt a free running 125-microsecond interrupt for the host controller. EHCI does not specify this interrupt but it has been added for convenience and as a potential an HCD time base. The interrupt is indicated and enabled in the USBSTS and USBINTR registers.

Capability Register Bit Fields Added

The following additions have been added to the capability registers:

- usb.HCSPARAMS [N_TT]
- usb.HCSPARAMS [N_PTT]

Operational Register and Bit Field Added

The following additions have been added to the operational registers:

- TTCTRL is a new register.
- Addition of two-bit Port Speed: usb.PORTSC1 [PSPD].

15.11.2 Embedded Transaction Translator

The host controller emulates one transaction translator (TT) with up to 16 periodic (Iso/Int) contexts and 2 asynchronous (bulk/ctrl) contexts. The TT allows FS/LS devices to be attached directly to the controller in host mode without the need for hardware to implement a companion controller.

The transaction translator is modeled as an extension to EHCI specification by making use of the standard data structures and operational models that exist in the EHCI specification. The TT is responsible for:

- All error checking
- Field generation checking
- Formatting of all the necessary handshake actions
- Ping and data response packets on the bus

For any signal that must be generated based on a USB based time in the host controller, the protocol engine also generates all of the token packets required by the USB protocol.

There is no separate transaction translator hardware to handle FS/LS protocols. The transaction translator function implemented within the DMA and the protocol engine blocks to support direct connection to LS and FS devices.

Functional Block Diagram

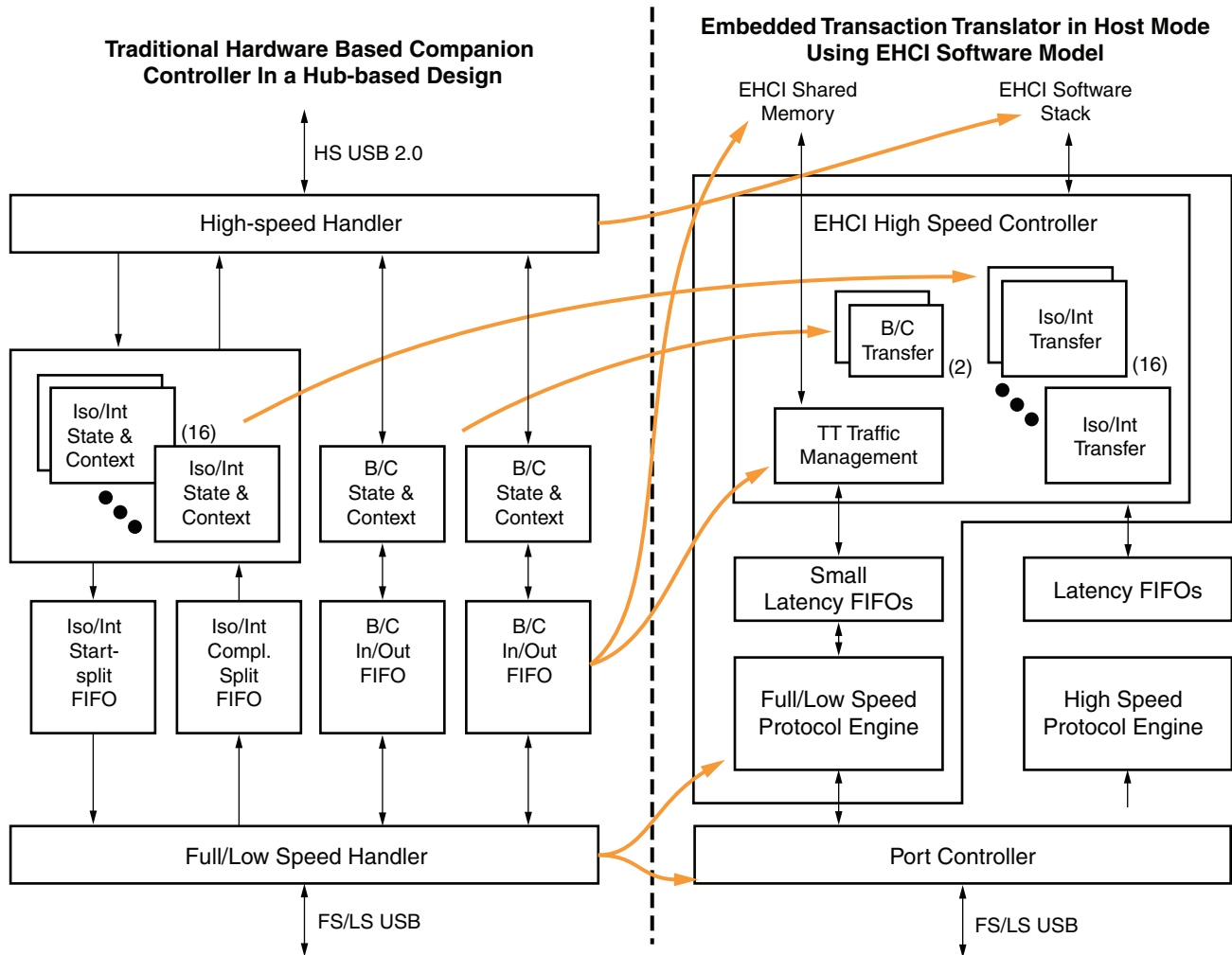

UG585_c15_11_030413

Figure 15-17: USB Host Embedded Transaction Translator Implementation

On the left side of Figure 15-17 is a typical hub implementation with a companion transaction translator controller. It shows two ongoing asynchronous transactions capable of ping-pong access from each end. Periodic traffic is aggregated into a single data stream for each direction while a table of state and context for each pipe is stored within the transaction translator.

The right side of Figure 15-17 shows how the same functions have been integrated into the host controller. The advantage of integrating those functions into the host controller is that the changes to the EHCI host controller driver (HCD) are minimal while allowing direct connection of FS and LS devices without the need for a companion controller or external USB 2.0 hub. In addition, the host controller with the transaction translator requires less local data storage than a hub-based transaction translator because the data storage is provided by main memory instead of hardware-based RAM. The host controller supports 16 periodic contexts and 2 asynchronous contexts.

15.11.3 EHCI Functional Changes for the TT

This section includes:

- Port Reset Timer to off-load software
- Port Speed detection

In a standard EHCI controller design, the Host controller driver (HCD) detects a full-speed or low-speed device by noting if the port enable bit is set after the port reset operation. The port enable is set after the port reset operation when the host and device negotiate a High-Speed connection (i.e., chirp completes successfully).

Because the controller emulates a transaction translator (TT), the port enable is always set after the port reset operation regardless of the result of the host device chirp result. The resulting port speed is indicated by the usb.PORTSC1 [PSPD] bit field.

Therefore, a standard EHCI HCD requires alteration to handle direct connection to Full and Low speed devices or hubs. The changes are fundamental and summarized in [Table 15-21](#).

Table 15-21: EHCI HCD Alteration

| Function | Standard EHCI | Embedded Transaction Translator |
|---------------|--|---|
| Hub Speed | After port enable bit is set following a connection and reset sequence, the device/hub is assumed to be HS. | After port enable bit is set following a connection and reset sequence, the device (hub) speed is noted from PORTSC1. |
| FS/LS devices | FS and LS devices are assumed to be downstream from a HS hub thus, all port-level control is performed through the Hub Class to the nearest Hub. | FS/LS device can be either downstream from an HS hub or directly attached. When its downstream, then port-level control is done using the Hub Class through the nearest Hub. When a FS/LS device is directly attached, then port-level control is accomplished using PORTSC1. |
| Split Target | FS and LS devices are assumed to be downstream from a HS hub with HubAddr=X; where HubAddr > 0 and HubAddr is the address of the Hub where the bus transitions from HS to FS/LS (i.e. Split target hub). | FS/LS device can be either downstream from a HS hub with HubAddr = X [HubAddr > 0] or directly attached; where HubAddr = [TTHA]. [TTHA] is programmable and defaults to 0. HubAddr is the address of the Root Hub where the bus transitions from HS to FS/LS (i.e. Split target hub is the root hub). |

15.11.4 Port Reset Timer Enhancement

The port connect methods specified by EHCI require setting the port reset bit in the PORTSC register for a duration of 10 ms. The controller has timers that can count the 10 ms reset pulse to alleviate the requirement of the HCD to control this timing. The basic connection for the HCD software:

Example: Port Reset Timer for Discovery

This example show a simple attach event and the step that is made optional because of the Port Reset Timer feature.

1. **Wait for device to attach.** Receive a port connect change [Port Change Interrupt].

2. **Reset the device.** Writes a 1 to the usb.PORTSC1 [PR] bit. assumes the
3. **Optional Step to de-assert Reset.** The HCD normally writes a 0 to the [PR] bit to de-assert the reset after 10 ms. This step, which is necessary in a standard EHCI design, can be omitted. Should the EHCI HCD attempt to write a 0 to the reset bit while a reset is in progress, the write is ignored and the reset continues until completion.
4. **Wait for device to be operational.** Receive the [PCI] interrupt to indicate the Port Enable Change. The device is now operational and at this point the port speed has been determined.

15.11.5 Port Speed Detection Mechanism

After the port change interrupt indicates that a port is enabled, the EHCI stack should determine the port speed. Unlike the EHCI implementation which re-assign the port owner for any device that does not connect at High-Speed, this host controller supports direct attach of non High-Speed devices. Therefore, the following differences are important regarding port speed detection:

- Port owner is read-only and always reads 0.
- A 2-bit port speed indicator (PSPD) has been added to PORTSC1 to provide the current operating speed of the port to the HCD.
- A 1-bit High Speed indicator (HSP) has been added to PORTSC1 to signify that the port is in High-Speed vs. Full/Low Speed - This information is redundant with the 2-bit Port Speed indicator above.

15.11.6 FS/LS Data Structures

The data structures used by the TT for FS/LS transactions are similar to an HS hub. The hub address and endpoint speed fields should be set for directly attached FS/LS devices and hubs:

- QH (FS/LS)- Asynchronous (Bulk and Control endpoints) and Periodic (Interrupt endpoint)
 - Hub Address = TTHA (default TTHA = 0)
 - Transactions to directly attached device or hub.
 - QH.EPS = Port Speed (for both FS and LS)
 - Transactions to a device downstream from direct attached HS hub.
 - QH.EPS = Downstream Device Speed
 - Maximum Packet Size must be less than or equal 64 or undefined behavior might result.
 - When QH.EPS = 01 (LS) and usb.PORTSC1 [PSPD] = 00 (FS), a LS-pre-PID will be sent before the transmitting LS traffic.
- siTD (FS) - Periodic (ISO endpoint)
 - All FS IsoUSB transactions:
 - Hub Address = (default TTHA = 0)
 - siTD.EPS = 00 (full speed)
 - Maximum Packet Size must less than or equal to 1023 or undefined behavior might result.

Note: FSTN data structures are used for FS and LS devices that are downstream of a high speed hub (not when FS or LS device is connected directly to the host controller.)

15.11.7 Operational Model of the TT

The operational models are well defined for the behavior of the transaction translator (see *USB 2.0 specification*) and for the EHCI controller to move packets between system memory and a USB-HS hub. Since the transaction translator exists within the host controller there is no physical bus between EHCI HCD and the USB FS/LS bus. These sections briefly discuss the operational model for how the EHCI and transaction translator operational models are combined without the physical bus between. The following sections assume the reader is familiar with both the EHCI and USB 2.0 transaction translator operational models.

Microframe Pipeline

The EHCI operational model uses the concept of H-frames and B-frames to describe the pipeline between the Host (H) and the Bus (B). The embedded transaction translator shall use the same pipeline algorithms specified in the USB 2.0 specification for a Hub-based Transaction Translator.

All periodic transfers always begin at B-frame 0 (after SOF) and continue until the stored periodic transfers are complete. As an example of the microframe pipeline implemented in the embedded transaction translator, all periodic transfers that are tagged in EHCI to execute in H-frame 0 will be ready to execute on the bus in B-frame 0.

It is important to note that when programming the S-mask and C-masks in the EHCI data structures to schedule periodic transfers for the embedded transaction translator, the EHCI HCD must follow the same rules specified in EHCI for programming the S-mask and C-mask for downstream hub-based transaction translators.

Once periodic transfers are exhausted, any stored asynchronous transfer will be moved. Asynchronous transfers are opportunistic in that they shall execute whenever possible and their operation is not tied to Hframe and B-frame boundaries with the exception that an asynchronous transfer cannot babble through the SOF (start of B-frame 0.)

Split Transfer State Machines

When the controller attaches to a downstream FS/LS device via an HS hub, the controller can initiate split transfers to allow for traffic to other devices to be intertwined.

The start and complete split operational model differs from EHCI slightly because there is no bus medium between the EHCI controller and the embedded transaction translator. Where a start or complete-split operation would occur by requesting the split to the HS hub, the start/complete split operation is simple an internal operation to the embedded transaction translator. [Table 15-22](#) summarizes the conditions where handshakes are emulated from internal state instead of actual handshakes to HS split bus traffic.

Table 15-22: USB Handshake Emulation Conditions

| Condition | TT Response |
|---|-------------|
| Start-Split: All asynchronous buffers full. | NAK |
| Start-Split: All periodic buffers full. | ERR |
| Start-Split: Success for start of async. transaction. | ACK |

Table 15-22: USB Handshake Emulation Conditions (Cont'd)

| Condition | TT Response |
|--|-------------------|
| Start-Split: Start periodic transaction. | No Handshake (OK) |
| Complete-Split: Failed to find transaction in queue. | Bus Time Out |
| Complete-Split: Transaction in queue is busy. | NYET |
| Complete-Split: Transaction in queue is complete. | Actual Handshake |

Asynchronous Transaction Scheduling and Buffer Management

The following USB 2.0 specification items are implemented in the Transaction Translator:

USB 2.0 - 11.17.3 Sequencing is provided and a packet length estimator ensures no full-speed/low-speed packet babbles into SOF time.

USB 2.0 - 11.17.4 Transaction tracking for 2 data pipes.

USB 2.0 - 11.17.5 Clear_TT_Buffer capability provided through the use of the TTCTRL register.

Periodic Transaction Scheduling and Buffer Management

The following USB 2.0 specification items are implemented in the transaction translator:

USB 2.0 - 11.18.6.[1-2] Abort of pending start-splits

- EOF (and not started in microframes 6)
- Idle for more than 4 microframes (Abort of pending complete-splits)
- EOF
- Idle for more than 4 microframes

USB 2.0 - 11.18.[7-8] Transaction tracking for up to 16 data pipes.

Caution: Limiting the number of tracking pipes in the embedded -TT to four (4) will impose the restriction that no more than four periodic transactions (INTERRUPT/ISOCHRONOUS) can be scheduled through the TT per frame. The number 16 was chosen in the USB specification because it is sufficient to ensure that the high-speed to full-speed periodic pipeline can remain full. Keeping the pipeline full puts no constraint on the number of periodic transactions that can be scheduled in a frame and the only limit becomes the flight time of the packets on the bus.

Note: There is no data schedule mechanism for these transactions other than the microframe pipeline. The emulated TT assumes the number of packets scheduled in a frame does not exceed the frame duration (1 ms) or else undefined behavior might result.

15.11.8 Port Test Mode

Port Test Control mode behaves as described by EHCI. The modes are set using the usb.PORTSC1 [PTC] bit field.

15.12 Host Data Structures Reference

These descriptor data structures are compatible with the EHCI specification with some differences as noted in section 15.11 EHCI Implementation.

The data structures defined in this section are (from the host controller's perspective) a mix of read-only and read/writable fields. The host controller preserves the read-only fields.

Section Content

- 15.12.1 Descriptor Usage
- 15.12.2 Transfer Descriptor Type (TYP) Field
- 15.12.3 Isochronous (High Speed) Transfer Descriptor (iTd)
- 15.12.4 Split Transaction Isochronous Transfer Descriptor (siTD)
- 15.12.5 Queue Element Transfer Descriptor (qTD)
- 15.12.6 Queue Head (QH)
- 15.12.7 Transfer Overlay Area
- 15.12.8 Periodic Frame Span Traversal Node (FSTN)

15.12.1 Descriptor Usage

Table 15-23: USB Host Descriptor Usage

| Descriptors | Periodic Frame List | | Asynchronous List | |
|-------------------------|---------------------|-----------|-------------------|---------|
| | Isochronous | Interrupt | Bulk | Control |
| iTD, siTD | yes | | no | no |
| QH, qTD | no | yes | yes | yes |
| FSTN (Low-, Full-speed) | no | yes | | |

15.12.2 Transfer Descriptor Type (TYP) Field

The Transaction Type bit field is defined and used in the situations listed in Table 15-24.

Table 15-24: USB Host Transfer Descriptor Type (TYP) Bit Field

| Data Structure | iTD 00 | QH 01 | siTD 10 | FSTN 11 | Description |
|---------------------|--------|-------|---------|---------|---|
| Periodic Frame List | X | X | X | X | Figure 15-15 USB Host Periodic Schedule with Example |
| iTD | X | ~ | ~ | ~ | Table 15-25 USB Host Isochronous Transfer Descriptor (iTd) Format |
| siTD | ~ | X | ~ | ~ | Table 15-29 USB Host Split-Transaction Isochronous Descriptor (siTD) Format |

Table 15-24: USB Host Transfer Descriptor Type (TYP) Bit Field (Cont'd)

| Data Structure | iTD 00 | QH 01 | siTD 10 | FSTN 11 | Description |
|----------------|--------|-------|---------|---------|---|
| QH | ~ | ~ | X | ~ | Table 15-40 USB Host Queue Head (QH) Descriptor Format |
| FSTN | ~ | ~ | ~ | X | Table 15-45 USB Host Frame Span Traversal Node Descriptor (FSTN) Format |

15.12.3 Isochronous (High Speed) Transfer Descriptor (iTDT)

The format of a high-speed isochronous transfer descriptor is illustrated in Table 15-25. This structure is used only for high-speed isochronous endpoints. The iTD's must be aligned on a 32-byte boundary.

Table 15-25: USB Host Isochronous Transfer Descriptor (iTDT) Format

| Reference | Type | 31 | 30 | 29 | 28 | 27 | 26 | 25 | 24 | 23 | 22 | 21 | 20 | 19 | 18 | 17 | 16 | 15 | 14 | 13 | 12 | 11 | 10 | 9 | 8 | 7 | 6 | 5 | 4 | 3 | 2 | 1 | 0 | DWord |
|-------------|--------------------------------|-------------------------|----------------------|----|----|----|----|----|----|----|----|----------|---------------------|----------------|------------------------|----|----|----|----|----|----|------|----|---|---|---|---|----|-----|---|---|---|---|-------|
| Table 15-26 | Next dTD | Next Link Pointer | | | | | | | | | | | | | | | | | | | | | | | | | | 00 | TYP | T | 0 | | | |
| Table 15-27 | Transaction Status and Control | Status | Transaction 0 Length | | | | | | | | | | iOC | PG * | Transaction 0 Offset * | | | | | | | | | | 1 | | | | | | | | | |
| | | Status | Transaction 1 Length | | | | | | | | | | iOC | PG * | Transaction 1 Offset * | | | | | | | | | | 2 | | | | | | | | | |
| | | Status | Transaction 2 Length | | | | | | | | | | iOC | PG * | Transaction 2 Offset * | | | | | | | | | | 3 | | | | | | | | | |
| | | Status | Transaction 3 Length | | | | | | | | | | iOC | PG * | Transaction 3 Offset * | | | | | | | | | | 4 | | | | | | | | | |
| | | Status | Transaction 4 Length | | | | | | | | | | iOC | PG * | Transaction 4 Offset * | | | | | | | | | | 5 | | | | | | | | | |
| | | Status | Transaction 5 Length | | | | | | | | | | iOC | PG * | Transaction 5 Offset * | | | | | | | | | | 6 | | | | | | | | | |
| | | Status | Transaction 6 Length | | | | | | | | | | iOC | PG * | Transaction 6 Offset * | | | | | | | | | | 7 | | | | | | | | | |
| | | Status | Transaction 7 Length | | | | | | | | | | iOC | PG * | Transaction 7 Offset * | | | | | | | | | | 8 | | | | | | | | | |
| Table 15-28 | Buffer Pointer List | Buffer Pointer (Page 0) | | | | | | | | | | EndPt | R | Device Address | | | | | | | | | | 9 | | | | | | | | | | |
| | | Buffer Pointer (Page 1) | | | | | | | | | | IO | Maximum Packet Size | | | | | | | | | | 10 | | | | | | | | | | | |
| | | Buffer Pointer (Page 2) | | | | | | | | | | reserved | | | | | | | | | | Mult | 11 | | | | | | | | | | | |
| | | Buffer Pointer (Page 3) | | | | | | | | | | reserved | | | | | | | | | | 12 | | | | | | | | | | | | |
| | | Buffer Pointer (Page 4) | | | | | | | | | | reserved | | | | | | | | | | 13 | | | | | | | | | | | | |
| | | Buffer Pointer (Page 5) | | | | | | | | | | reserved | | | | | | | | | | 14 | | | | | | | | | | | | |
| | | Buffer Pointer (Page 6) | | | | | | | | | | reserved | | | | | | | | | | 15 | | | | | | | | | | | | |

 Host Controller Read/Write  Host Controller Read-only

* means these fields may be modified by the Host controller if the IO field indicates an OUT (DWords 1 to 8).

iTD DWord 0: Next Link Pointer

The first DWord of an iTD is a pointer to the next schedule data structure.

Table 15-26: USB Host iTD DWord 0: Next Link Pointer

| Bits | Description |
|------|--|
| 31:5 | Next Link Pointer. These bits correspond to memory address signals [31:5], respectively. This field points to another isochronous transaction descriptor (iTDT/siTD) or a QH. |
| 4:3 | Reserved. Field reserved and should be set to 0. |

Table 15-26: USB Host iTD DWord 0: Next Link Pointer (Cont'd)

| Bits | Description |
|------|---|
| 2:1 | Transaction Descriptor Type, TYP . Set to 00 (iTID type). Refer to section 15.12.2 Transfer Descriptor Type (TYP) Field for general information. |
| 0 | Terminate transfer, T . <ul style="list-style-type: none"> • 0: link to the Next iTD Pointer field; the address is valid. • 1: end the transaction, the Next iTD Pointer field is not valid. |

iTD DWords 1 to 8: Transaction Status and Control List

DWords 1 through 8 are transaction control and status. Each transaction description includes:

- Status results field
- Transaction length (bytes to send for OUT transactions and bytes received for IN transactions)
- Buffer offset. The PG and Transaction x Offset fields are used with the buffer pointer list to construct the starting buffer address for the transaction

The host controller uses the information in each transaction description plus the endpoint information contained in the first three DWords of the Buffer Page Pointer list, to execute a transaction on the USB.

Table 15-27: USB Host iTD Dwords 1 to 8: Transaction Status and Control List

| Bits | Description |
|-------|--|
| 31:28 | <p>Status:</p> <p>Active Status [31]. Set to 1 by the HCD to enable the execution of an isochronous transaction. When the transaction associated with this descriptor is completed, the host controller sets this bit to 0 indicating that a transaction for this element should not be executed when it is next encountered in the schedule.</p> <p>Data Buffer Error Status [30]. Set to a 1 by the host controller during status update to indicate that the host controller is unable to keep up with the reception of incoming data (overrun) or is unable to supply data fast enough during transmission (under run). If an overrun condition occurs, no action is necessary.</p> <p>Babble Detected Status [29]. Set to 1 by the host controller during status update when 'babble' is detected during the transaction generated by this descriptor.</p> <p>Transaction Error Status [28]. Set to 1 by the host controller during status update in the case where the host did not receive a valid response from the device (Timeout, CRC, Bad PID, etc.). This bit can only be set for isochronous IN transactions.</p> |
| 27:16 | <p>Transaction {7:0} Length. For an OUT transaction, this field is the number of data bytes the host controller will send during the transaction. The host controller is not required to update this field to reflect the actual number of bytes transferred during the transfer.</p> <p>For an IN transaction, the initial value of the field is the number of bytes the host expects the endpoint to deliver. During the status update, the host controller writes back the field the number of bytes successfully received.</p> <ul style="list-style-type: none"> • 000h: zero length data. • 001h: one byte. • 002h: two bytes. • ... • C00h: 3072 bytes (maximum). |

Table 15-27: USB Host iTD Dwords 1 to 8: Transaction Status and Control List (Cont'd)

| Bits | Description |
|-------|--|
| 15 | Interrupt On Complete, IOC . If this bit is set to 1, it specifies that when this transaction completes, the host controller should issue an interrupt at the next interrupt threshold. |
| 14:12 | Page Select, PG . These bits are set by the HCD to indicate which of the buffer page pointers the offset field in this slot should be concatenated to produce the starting memory address for this transaction. The valid range of values for this field is 0 to 6. |
| 11:0 | Transaction {7:0} Offset . This field is a value that is an offset, expressed in bytes, from the beginning of a buffer. This field is concatenated onto the buffer page pointer indicated in the adjacent PG field to produce the starting buffer address for this transaction. |

iTD DWords 9 to 15: Buffer Page Pointer List

DWords 9-15 of an isochronous transaction descriptor are nominally page pointers (4 KB aligned) to the data buffer for this transfer descriptor. This data structure requires the associated data buffer to be contiguous, but allows the physical memory pages to be non-contiguous. Seven page pointers are provided to support the expression of eight isochronous transfers. The seven pointers allow for 3 (transactions) * 1,024 (maximum packet size) * 8 (transaction records) (24,576 bytes) to be moved with this data structure, regardless of the alignment offset of the first page.

Since each pointer is a 4 KB aligned page pointer, the least significant 12 bits in several of the page pointers are used for other purposes.

Table 15-28: USB Host iTD DWords 9 to 15: Buffer Page Pointer List

| Bits | Description |
|-----------------|--|
| DWord 9 | |
| 31:12 | Buffer Pointer (Page 0) . 4KB-aligned pointer to system memory address bits [31:12]. |
| 11:8 | Endpoint Number (EndPt) . Select the endpoint for the device serving as the data source or sink. |
| 7 | Reserved. Bit reserved for future use and should be initialized by the HCD to 0. |
| 6:0 | Device Address . Select the specific device serving as the data source or sink. |
| DWord 10 | |
| 31:12 | Buffer Pointer (Page 1) . 4KB-aligned pointer to system memory address bits [31:12]. |
| 11 | Direction (IO) . Select the high-speed transaction for an IN or OUT PID. <ul style="list-style-type: none"> • 0: OUT • 1: IN |
| 10:0 | Maximum Packet Size . This directly corresponds to the maximum packet size of the associated endpoint (wMaxPacketSize). This field is used for high-bandwidth endpoints where more than one transaction is issued per transaction description (e.g., per microframe). This field is used with the Multi field to support high-bandwidth pipes. This field is also used for all IN transfers to detect packet babble. The HCD should not set a value larger than 1,024 (400h). Any value larger yields undefined results. |
| DWord 11 | |
| 31:12 | Buffer Pointer (Page 2) . 4KB-aligned pointer to system memory address bits [31:12]. |
| 11:2 | Reserved. This bit reserved for future use and should be set to 0. |

Table 15-28: USB Host iTD DWords 9 to 15: Buffer Page Pointer List (Cont'd)

| Bits | Description |
|------------------------|--|
| 1:0 | <p>Mult. Selects the number of transactions to execute per transaction description (e.g. per microframe).</p> <ul style="list-style-type: none"> • 00: Reserved. A 0 in this field yields undefined results • 01: One transaction to be issued for this endpoint per microframe • 10: Two transactions to be issued for this endpoint per microframe • 11: Three transactions to be issued for this endpoint per microframe |
| DWords 12 to 15 | |
| 31:12 | Buffer Pointer (Pages 3 to 6). 4KB-aligned pointer to memory address bits [31:12]. |
| 11:0 | Reserved. This bit reserved for future use and should be set to 0. |

15.12.4 Split Transaction Isochronous Transfer Descriptor (siTD)

This data structure is used to manage FS isochronous transfers via split transactions to USB 2.0 Hub Transaction Translator. There are additional fields used for addressing the hub and scheduling the protocol transactions (for periodic).

Table 15-29: USB Host Split-Transaction Isochronous Descriptor (siTD) Format

| Reference | Type | 31 | 30 | 29 | 28 | 27 | 26 | 25 | 24 | 23 | 22 | 21 | 20 | 19 | 18 | 17 | 16 | 15 | 14 | 13 | 12 | 11 | 10 | 9 | 8 | 7 | 6 | 5 | 4 | 3 | 2 | 1 | 0 | DWord |
|-------------|------------------|-------------------------|-------------|----------|----|----|----|----|----|-------------|----|----|----|-------------------|----|------------------------|----|----|----|-------------------|---------|--------|----|----------------|---|----|-----|---|---|---|---|---|---|-------|
| Table 15-30 | Next Ptr | Next Link Pointer | | | | | | | | | | | | | | | | | | | | | | | | 00 | TYP | T | 0 | | | | | |
| Table 15-31 | Endpt Cap/Char | IO | Port Number | | | | | | R | Hub Addr | | | | | | reserved | | | | | | EndPt | R | Device Address | | | | | | 1 | | | | |
| | | reserved | | | | | | | | | | | | Microframe C-mask | | | | | | Microframe S-mask | | | | | | 2 | | | | | | | | |
| Table 15-32 | xfer State | ioc | P | reserved | | | | | | Total Bytes | | | | | | Microframe C-prog-mask | | | | | | Status | | | | | | 3 | | | | | | |
| Table 15-33 | Buffer Page Ptrs | Buffer Pointer (Page 0) | | | | | | | | | | | | Current Offset | | | | | | | | | | | | 4 | | | | | | | | |
| | | Buffer Pointer (Page 1) | | | | | | | | | | | | reserved | | | | | | TP | T-count | 5 | | | | | | | | | | | | |
| Table 15-34 | Back Link | Back Pointer | | | | | | | | | | | | | | | | | | | | | | | | 0 | T | 6 | | | | | | |

Host Controller Read/Write
 Host Controller Read-only

siTD DWord 0: Next Link Pointer

DWord 0 of a siTD is a pointer to the next schedule data structure.

Table 15-30: USB Host siTD DWord 0: Next Link Pointer

| Bits | Description |
|------|---|
| 31:5 | Next Link Pointer. This field contains the address of the next data object to be processed in the periodic list and corresponds to memory address signals [31:5], respectively. |
| 2:1 | Transaction Descriptor Type, TYP . Set to 10 (siTD type). Refer to section 15.12.2 Transfer Descriptor Type (TYP) Field for general information. |
| 0 | Terminate transfer, T . <ul style="list-style-type: none"> • 0: link to the Next Link Pointer field; the address is valid. • 1: end the transaction, the Next Link Pointer field is not valid. |

siTD DWords 1 and 2: Endpoint Capabilities and Characteristics

DWords 1 and 2 specify static information about the full-speed endpoint, the addressing of the parent Companion Controller, and microframe scheduling control.

Table 15-31: USB Host siTD DWords 1 and 2:Endpoint State

| Bits | Description |
|---|--|
| DWord 1: Endpoint and Transaction Translator Characteristics | |
| 31 | Direction, IO . Encodes the FS transaction as an IN or OUT. <ul style="list-style-type: none"> • 0: OUT • 1: IN |
| 30:24 | Port Number. This field is the port number of the recipient Transaction Translator. |
| 23 | Reserved. Bit reserved and should be set to 0. |
| 22:16 | Hub Address, Hub Addr . Device address of the Companion Controller's hub. |

Table 15-31: USB Host siTD DWords 1 and 2:Endpoint State (Cont'd)

| Bits | Description |
|---|--|
| 15:12 | Reserved. Field reserved and should be set to 0. |
| 11:8 | Endpoint Number, EndPt . 4-bit field selects the endpoint on the device serving as the data source or sink. |
| 7 | Reserved. Bit reserved and should be set to 0. |
| 6:0 | Device Address . Select the specific device serving as the data source or sink. |
| DWord 2: Microframe Schedule Control | |
| 31:16 | Reserved. Field reserved and should be set to 0. |
| 15:8 | Split Completion Mask, Microframe C-mask . This field (along with the Active and SplitXstate fields in the Status byte) is used to determine during which microframes the host controller should execute complete-split transactions. Refer to the text for details. |
| 7:0 | Split Start Mask, Microframe S-mask . This field (along with the Active and SplitX-state fields in the Status byte) is used to determine during which microframes the host controller should execute start-split transactions. Refer to the text for details. |

Microframe C-mask

The split completion mask field, siTD.Microframe C-mask, along with the Active and SplitXstate fields in the Status byte, is used to determine during which microframes the host controller should execute complete-split transactions. This field is a straight bit position field, so if bit [0] is set then the complete-split transaction should occur in the first microframe, if bit [1] is set = 1 then it should occur in the second microframe, and so on. When the criteria for using this field is met, a 0 value has undefined behavior.

The host controller uses the value of the three low-order bits of the FRINDEX register to index into this bit field. If the FRINDEX register value indexes to a position where the microframe C-Mask field is a 1, then this siTD is a candidate for transaction execution.

There can be more than one bit in this mask set.

The C-Mask can be set for multiple micro frames, as it is not known in which microframe the transaction will complete. So the C-Mask can be set for the micro frame after the S-Mask and all subsequent micro frames thereafter. The C-Mask field should not have a bit set to the same microframe as the S-Mask is set to.

Microframe S-mask

The split start mask field, siTD.Micro S-mask, along with the Active and SplitX-state fields in the Status byte, is used to determine during which microframes the host controller should execute start-split transactions.

The host controller uses the value of the three low-order bits of the FRINDEX register to index into this bit field. If the FRINDEX register value indexes to a position where the microframe S-mask field is a 1, then this siTD is a candidate for transaction execution.

A 0 value in this field, in combination with existing periodic frame list, has undefined results.

This field should have only one bit set to 1 at any given time. Having more than one bit set will result in undefined results.

siTD DWord 3: Transfer Status and Control

DWord 3 is used to manage the state of the split data transfer.

Table 15-32: USB Host siTD DWord 3: Transfer Status and Control

| Bits | Description |
|-------|--|
| 31 | Interrupt On Complete, IOC . <ul style="list-style-type: none"> • 0: Do not interrupt when transaction is complete • 1: Do interrupt when transaction is complete When the host controller determines that the split transaction has completed it will assert a hardware interrupt at the next interrupt threshold. |
| 30 | Page Select, P . Used to indicate which data page pointer should be concatenated with the Current Offset field to construct a data buffer pointer (0 selects Page 0 pointer and 1 selects Page 1). The host controller is not required to write this field back when the siTD is retired (Active bit transitioned from a 1 to a 0). |
| 29:26 | Reserved. Field reserved and should be set to 0. |
| 25:16 | Total Bytes To Transfer, Total Bytes . This field is initialized by the HCD to the total number of bytes expected in this transfer. Maximum value is 1,023 (3FFh). |
| 15:8 | Microframe Complete-split Progress Mask, uFrame C prog-mask . This field is used by the host controller to record which split-completes has been executed. |
| 7:0 | Status [7:0] . Refer to text. |

Status bits [7:0]

- **Active Status [7]**. Set to 1 by the HCD to enable the execution of an isochronous split transaction by the Host Controller
- **ERR Status [6]**. Set to a 1 by the host controller when an ERR response is received from the Companion Controller.
- **Data Buffer Error Status [5]**. Set to a 1 by the host controller during status update to indicate that the host controller is unable to keep up with the reception of incoming data (overrun) or is unable to supply data fast enough during transmission (under run). In the case of an under run, the host controller will transmit an incorrect CRC (thus invalidating the data at the endpoint). If an overrun condition occurs, no action is necessary.
- **Babble Detected Status [4]**. Set to 1 by the Host Controller during status update when 'babble' is detected during the transaction generated by this descriptor.
- **Transaction Error Status [3]**. Set to 1 by the host controller during status update in the case where the host did not receive a valid response from the device (Timeout, CRC, Bad PID, etc.). This bit can only be set for isochronous IN transactions.
- **Missed Microframe Status [2]**. The host controller detected that a host-induced holdoff caused the host controller to miss a required complete-split transaction.
- **Split Transaction State Status [1]**.
 - 0: Do Start Split. This value directs the host controller to issue a Start split transaction to the endpoint when a match is encountered in the S-mask.
 - 1: Do Complete Split. This value directs the host controller to issue a Complete split transaction to the endpoint when a match is encountered in the C-mask.
- **Reserved [0]**. Bit reserved for future use and should be set to 0.

siTD DWords 4 and 5: Buffer Pointer List

DWords 4 and 5 are the data buffer page pointers for the transfer. This structure supports one physical page cross. The most significant 20 bits of each DWord in this section are the 4K (page) aligned buffer pointers. The least significant 12 bits of each DWord are used as additional transfer state.

Table 15-33: USB Host siTD DWords 4 and 5: Buffer Pointers

| Bits | Description |
|----------------|--|
| DWord 4 | |
| 31:12 | Buffer Pointer (Page 0). 4 KB aligned pointer to system memory address bits [31:12]. |
| 11:0 | Current Offset. The 12 least significant bits of the Page 0 pointer is the current byte offset for the current page pointer (as selected with the page select bit (P field)). The host controller is not required to write this field back when the siTD is retired (Active bit transitioned from a 1 to a 0). |
| DWord 5 | |
| 31:12 | Buffer Pointer (Page 1). 4 KB aligned pointer to system memory address bits [31:12]. |
| 11:5 | Reserved. Bit reserved for future use and should be set to 0. |
| 4:3 | Transition position, TP . This field is used with T-count to determine whether to send all, first, middle, or last with each outbound transaction payload. The HCD must initialize this field with the appropriate starting value. The host controller must correctly manage this state during the lifetime of the transfer. The bit encodings are: <ul style="list-style-type: none"> • 00: All. Entire FS transaction data payload is in this transaction (the payload is less than or equal to 188 bytes.) • 01: Begin. First data payload for a FS transaction that is greater than 188 bytes. • 10: Mid. Middle payload for a FS OUT transaction that is greater than 188 bytes. • 11: End. Last payload for a FS OUT transaction that was greater than 188 bytes. |
| 2:0 | Transaction count, T-Count . The HCD initializes this field with the number of OUT start-splits this transfer requires. Any value larger than 6 is undefined. |

siTD DWord 6: Back Link Pointer

DWord 6 of a siTD is simply another schedule link pointer. This pointer is either 0 or references an siTD data structure. This pointer cannot reference any other schedule data structure.

Table 15-34: USB Host siTD DWord 6: Back Pointer

| Bits | Description |
|------|---|
| 31:5 | Back Pointer. Physical memory pointer to a siTD. |
| 4:1 | Reserved. Field reserved and should be set to 0. |
| 0 | Terminate transfer, T . <ul style="list-style-type: none"> • 0: link to the Back Pointer field; the address is valid. • 1: end the transaction, the Back Pointer field is not valid. |

15.12.5 Queue Element Transfer Descriptor (qTD)

This data structure is only used with a queue head. This data structure is used for one or more USB transactions. This data structure is used to transfer up to 20,480 (5 times 4,096) bytes. The structure contains two structure pointers used for queue advancement, a DWord of transfer state, and a five-element array of data buffer pointers. This structure is 32 bytes (or one 32-byte cache line). This data structure must be physically contiguous.

The buffer associated with this transfer must be virtually contiguous. The buffer can start on any byte boundary. A separate buffer pointer list element must be used for each physical page in the buffer, regardless of whether the buffer is physically contiguous.

Host controller updates (host controller writes) to stand-alone qTD's only occur during transfer retirement. References in the following bit field definitions of updates to the qTD are to the qTD portion of a queue head.

Table 15-35: USB Host Transfer Descriptor (qTD) Format

| Reference | Type | 31 | 30 | 29 | 28 | 27 | 26 | 25 | 24 | 23 | 22 | 21 | 20 | 19 | 18 | 17 | 16 | 15 | 14 | 13 | 12 | 11 | 10 | 9 | 8 | 7 | 6 | 5 | 4 | 3 | 2 | 1 | 0 | DWord |
|-------------|-----------------------|----------------------------|-------------------------|-------------|----|----|----|----|----|----|----|----|----|----|----|----------|----------------|-----|--------|-------|-----|--------|----|---|---|---|---|------|---|---|---|---|---|-------|
| Table 15-36 | Transfer Overlay Area | Next qTD Pointer | | | | | | | | | | | | | | | | | | | | | | | | | | 0000 | T | 0 | | | | |
| Table 15-37 | | Alternate Next qTD Pointer | | | | | | | | | | | | | | | | | | | | | | | | | | 0000 | T | 1 | | | | |
| Table 15-38 | | Transfer Results | DT | Total Bytes | | | | | | | | | | | | | | ioc | C_Page | C_err | PID | Status | | | | | | | 2 | | | | | |
| Table 15-39 | | | Buffer Pointer (Page 0) | | | | | | | | | | | | | | Current Offset | | | | | | | 3 | | | | | | | | | | |
| | | Buffer Pointer (Page 1) | | | | | | | | | | | | | | reserved | | | | | | | 4 | | | | | | | | | | | |
| | | Buffer Pointer (Page 2) | | | | | | | | | | | | | | reserved | | | | | | | 5 | | | | | | | | | | | |
| | | Buffer Pointer (Page 3) | | | | | | | | | | | | | | reserved | | | | | | | 6 | | | | | | | | | | | |
| | | Buffer Pointer (Page 4) | | | | | | | | | | | | | | reserved | | | | | | | 7 | | | | | | | | | | | |

Host Controller Read/Write
 Host Controller Read-only

qTD DWord 0: Next Pointer

The first DWord of an element transfer descriptor is a pointer to another transfer element descriptor.

Table 15-36: USB Host qTD DWord 0: Next Element Transfer Pointer

| Bits | Description |
|------|---|
| 31:5 | Next Transfer Element Pointer, Next qTD Pointer . This field contains the physical memory address of the next qTD to be processed. The field corresponds to memory address bits [31:5], respectively. |
| 4:1 | Reserved. Field reserved and should be set to 0. |
| 0 | Terminate transfer, T . <ul style="list-style-type: none"> • 0: link to the Next qTD Pointer field; the address is valid. • 1: end the transaction, the Next qTD Pointer field is not valid. |

qTD DWord 1: Alternate Next Element Pointer

The second DWord of a queue element transfer descriptor is used to support hardware-only advance of the data stream to the next client buffer on short packet. To be more explicit the host controller will always use this pointer when the current qTD is retired due to short packet.

Table 15-37: USB Host qTD DWord 1: Alternate Next Element Pointer

| Bits | Description |
|------|---|
| 31:5 | Alternate Next Transfer Element Pointer, Alternate Next qTD Pointer . This field contains the physical memory address of the next qTD to be processed in the event that the current qTD execution encounters a short packet (for an IN transaction). The field corresponds to memory address signals [31:5], respectively. |
| 4:1 | Reserved. Field reserved and should be set to 0. |
| 0 | Terminate transfer, T . <ul style="list-style-type: none"> 0: link to the Alternate Next dTD Pointer field; the address is valid. 1: end the transaction, the Alternate Next dTD Pointer field is not valid. |

qTD DWord 2: Token

The third DWord of a queue element transfer descriptor contains most of the information the host controller requires to execute a USB transaction (the remaining endpoint-addressing information is specified in the queue head). The status field reflects the last transaction performed on this qTD.

Note: The field descriptions forward reference fields defined in the queue head. Where necessary, these forward references are preceded with a QH notation.

Table 15-38: USB Host qTD DWord 2: DT, Total Bytes

| Bits | Description |
|-------|--|
| 31 | Data Toggle, DT . This is the data toggle sequence bit. The use of this bit depends on the setting of the Data Toggle Control bit in the queue head. |
| 30:16 | Total Bytes to Transfer, Total Bytes . This field specifies the total number of bytes to be moved with this transfer descriptor. Refer to section Total Bytes to Transfer Parameter for more info. |
| 15 | Interrupt On Complete, IOC . If this bit is set to a 1, it specifies that when this qTD is completed, the host controller should issue an interrupt at the next interrupt threshold. |
| 14:12 | Current Page, C_Page . This field is used as an index into the qTD buffer pointer list. Valid values are in the range 0 to 4. The host controller is not required to write this field back when the qTD is retired. |

Table 15-38: USB Host qTD DWord 2: DT, Total Bytes (Cont'd)

| Bits | Description | | | | | | | | | | |
|-------------------|--|-------------------|-----|-------|-----------------------|-----------------|-----------------------|----------|-----------------------|-------------------|-----------------------|
| 11:10 | <p>Error Counter, Cerr. This field is a 2-bit <i>down</i> counter that keeps track of the number of consecutive Errors detected while executing this qTD.</p> <p>HCD write:</p> <ul style="list-style-type: none"> • 00: the controller will not count errors for this qTD and there will be no limit on the retries of this qTD. • 01 to 11: the controller decrements this field for each consecutive USB transaction error [UEI] that occurs while processing this qTD. If the counter counts from 01 to 00, the controller marks the qTD inactive, sets the Halted bit = 1, and sets the usb.USBINTR [CERR] error status bit. <table border="0" data-bbox="391 569 927 716"> <tr> <td>Transaction Error</td> <td>Yes</td> </tr> <tr> <td>Stall</td> <td>No, see note 1 below.</td> </tr> <tr> <td>Babble Detected</td> <td>No, see note 1 below.</td> </tr> <tr> <td>No Error</td> <td>No, see note 2 below.</td> </tr> <tr> <td>Data Buffer Error</td> <td>No, see note 3 below.</td> </tr> </table> <p>Notes:</p> <ol style="list-style-type: none"> 1. Detection of Babble or Stall automatically halts the queue head. Thus, count is not decremented 2. If the QH.EPS field indicates a HS device or the queue head is in the Asynchronous Schedule (and PID code indicates an IN or OUT) and a bus transaction completes and the host controller does not detect a transaction error, then the host controller should reset Cerr to extend the total number of errors for this transaction. For example, Cerr should be reset with maximum value (3) on each successful completion of a transaction. The host controller must never reset this field if the value at the start of the transaction is 00b. 3. Data buffer errors are host problems. They don't count against the device's retries. <p>Note: The HCD must not program Cerr to a value of 0 when the QH.EPS field is programmed with a value indicating a FS or LS device. This combination could result in undefined behavior.</p> | Transaction Error | Yes | Stall | No, see note 1 below. | Babble Detected | No, see note 1 below. | No Error | No, see note 2 below. | Data Buffer Error | No, see note 3 below. |
| Transaction Error | Yes | | | | | | | | | | |
| Stall | No, see note 1 below. | | | | | | | | | | |
| Babble Detected | No, see note 1 below. | | | | | | | | | | |
| No Error | No, see note 2 below. | | | | | | | | | | |
| Data Buffer Error | No, see note 3 below. | | | | | | | | | | |
| 9:8 | <p>PID Code, PID. This field is an encoding of the token, which should be used for transactions associated with this transfer descriptor. Encodings are:</p> <ul style="list-style-type: none"> • 00: DUT. Token generates token (E1h) • 01: IN. Token generates token (69h) • 10: Setup. Token generates token (2Dh) (undefined if end-point is an Interrupt transfer type, e.g. microFrame S-mask field in the queue head is non-zero.) • 11: Reserved. | | | | | | | | | | |
| 7 | <p>Active Status. Set to 1 by the HCD to enable the execution of transactions by the host controller.</p> | | | | | | | | | | |
| 6 | <p>Halted Status. Set to a 1 by the host controller during status updates to indicate that a serious error has occurred at the device/endpoint addressed by this qTD. This can be caused by babble, the error counter counting down to 0, or reception of the STALL handshake from the device during a transaction. Any time that a transaction results in the Halted bit being set to a 1, the Active bit is also set to 0.</p> | | | | | | | | | | |
| 5 | <p>Data Buffer Error Status. Set to a 1 by the Host Controller during status update to indicate that the Host Controller is unable to keep up with the reception of incoming data (overrun) or is unable to supply data fast enough during transmission (under run). If an overrun condition occurs, the Host Controller will force a timeout condition on the USB, invalidating the transaction at the source. If the host controller sets this bit to a 1, then it remains a 1 for the duration of the transfer.</p> | | | | | | | | | | |
| 4 | <p>Babble Detected Status. Set to a 1 by the host controller during status update when "babble" is detected during the transaction. In addition to setting this bit, the host controller also sets the Halted bit to a 1. Since "babble" is considered a fatal error for the transfer, setting the Halted bit to a 1 insures that no more transactions occur because of this descriptor.</p> | | | | | | | | | | |

Table 15-38: USB Host qTD DWord 2: DT, Total Bytes (Cont'd)

| Bits | Description |
|------|--|
| 3 | Transaction Error Status. Set to a 1 by the host controller during status update in the case where the host did not receive a valid response from the device (Timeout, CRC, Bad PID, etc.). If the controller sets this bit to a 1, then it remains a 1 for the duration of the transfer. |
| 2 | Missed Microframe Status. This bit is ignored unless the QH.EPS field indicates a full- or low-speed endpoint and the queue head is in the periodic list. This bit is set when the host controller detected that a host-induced hold-off caused the controller to miss a required complete-split transaction. If the controller sets this bit to a 1, then it remains a 1 for the duration of the transfer. |
| 1 | Split Transaction State Status. This bit is ignored by the host controller unless the QH.EPS field indicates a FS or LS endpoint. When a Full- or Low speed device, the host controller uses this bit to track the state of the split transaction. The functional requirements of the controller for managing this state bit and the split transaction protocol depends on whether the endpoint is in the periodic or asynchronous schedule. <ul style="list-style-type: none"> • 0: Do Start Split. This value directs the host controller to issue a Start split transaction to the endpoint. • 1: Do Complete Split. This value directs the host controller to issue a Complete split transaction to the endpoint. |
| 0 | Ping State/ERR Status. If the QH.EPS field indicates a HS device and the PID indicates an OUT endpoint, then this is the state bit for the Ping protocol. <ul style="list-style-type: none"> • 0: Do OUT. This value directs the controller to issue an OUT PID to the endpoint. • 1: Do Ping. This value directs the controller to issue a Ping PID to the endpoint. If the QH.EPS field does not indicate a HS device, then this field is used as an error indicator bit. It is set to a 1 by the controller whenever a periodic split-transaction receives an ERR handshake. |

qTD DWord 3 to 7: Buffer page Pointer List

The last five DWords of a queue element transfer descriptor is an array of physical memory address pointers. These pointers reference the individual pages of a data buffer.

The HCD initializes current offset field to the starting offset into the current page, where current page is selected via the value in the C_Page field.

The field C_Page specifies the current active pointer. When the transfer element descriptor is fetched, the starting buffer address is selected using C_Page (similar to an array index to select an array element). If a transaction spans a 4 KB buffer boundary, the host controller must detect the page-span boundary in the data stream, increment C_Page and advance to the next buffer pointer in the list, and conclude the transaction via the new buffer pointer.

Table 15-39: USB Host qTD DWord 3 to 7: Buffer Pointers



| Bits | Description |
|-----------|---|
| 31:1 2 | DWords 3 to 7: Buffer Pointer. 4KB page-aligned memory address. |
| 11:0 | DWord 3: Current Offset. Byte offset into the active page (as selected by C_Page). The host controller is not required to write this field back when the qTD is retired. DWords 4 to 7: Reserved. Field reserved and should be set to 0. |

15.12.6 Queue Head (QH)

The first three DWords of the QH include Static State information about the endpoint. The current qTD pointer is the system memory address pointer for the current qTD and is updated by the hardware when a new qTD is written (overlaid) in the QH's overlay area.

Table 15-40: USB Host Queue Head (QH) Descriptor Format

| Reference | Type | 31 | 30 | 29 | 28 | 27 | 26 | 25 | 24 | 23 | 22 | 21 | 20 | 19 | 18 | 17 | 16 | 15 | 14 | 13 | 12 | 11 | 10 | 9 | 8 | 7 | 6 | 5 | 4 | 3 | 2 | 1 | 0 | DWord |
|-------------|-----------------------|------------------------------------|---------------|-----------------------|----|----|------------|----|-----|--------|-----------------|----------------|--------|----|----------------|----|-------------------|----|----|----|----|----|----|---|---|---|--------|-----|---|---|---|---|---|-------|
| Table 15-41 | Static Endpoint State | Queue Head Horizontal Link Pointer | | | | | | | | | | | | | | | | | | | | | | | | | 00 | TYP | T | 0 | | | | |
| Table 15-42 | | RL | C | Maximum Packet Length | | | | | | H | DTC | EPS | EndPt | I | Device Address | | | | | | | | | | | | | 1 | | | | | | |
| | | Mult | Port Number * | | | | Hub Addr * | | | | uFrame C-mask * | | | | uFrame S-mask | | | | | | | 2 | | | | | | | | | | | | |
| Table 15-43 | Current Pointer | Current qTD Pointer | | | | | | | | | | | | | | | | | | | | | | | | | 00000 | | | 3 | | | | |
| Table 15-44 | Transfer Overlay Area | Next qTD Pointer | | | | | | | | | | | | | | | | | | | | | | | | | 0000 | T | 4 | | | | | |
| | | Alternate Next qTD Pointer | | | | | | | | | | | | | | | | | | | | | | | | | NakCnt | | T | 5 | | | | |
| | | DT | Total Bytes | | | | | | ioc | C_Page | C_err | PID | Status | | | | P | 6 | | | | | | | | | | | | | | | | |
| | | Buffer Pointer (Page 0) | | | | | | | | | | Current Offset | | | | | | | | | | | | | | | 7 | | | | | | | |
| | | Buffer Pointer (Page 1) | | | | | | | | | | reserved | | | | | C-prog-mask * | | | | | 8 | | | | | | | | | | | | |
| | | Buffer Pointer (Page 2) | | | | | | | | | | S-Bytes * | | | | | Split_Frame_Tag * | | | | | 9 | | | | | | | | | | | | |
| | | Buffer Pointer (Page 3) | | | | | | | | | | reserved | | | | | | | | | | | | | | | 10 | | | | | | | |
| Table 15-45 | | Buffer Pointer (Page 4) | | | | | | | | | | reserved | | | | | | | | | | | | | | | 11 | | | | | | | |

 Host Controller Read/Write  Host Controller Read-only
 * means these fields are used exclusively to support Split Transactions to USB 2.0 Hubs.

QH Horizontal Link Pointer, DWord 0

The first DWord of a Queue Head contains a link pointer to the next data object to be processed after any required processing in this queue has been completed, as well as the control bits defined below. This pointer can reference a queue head or one of the isochronous transfer descriptors. It must not reference a queue element transfer descriptor.

Table 15-41: USB Host QH DWord 0: Link Pointer

| Bits | Description |
|------|--|
| 31:5 | Queue Head Horizontal Link Pointer. System memory address of the next data object in the periodic list. |
| 4:3 | Reserved. Field reserved and should be set to 0. |
| 2:1 | Transaction Descriptor Type, TYP . Set to 01 (QH type). Refer to section 15.12.2 Transfer Descriptor Type (TYP) Field for general information. |
| 0 | Termination Bit, T . Periodic List Schedule response: 0: link to the next QH; the Queue Head Horizontal Link Pointer field is valid. 1: end of the periodic list processing; the pointer field is invalid. Asynchronous Schedule response: Ignored. |

QH DWords 1 and 2: Endpoint Capabilities and Characteristics

The second and third DWords of a Queue Head specifies static information about the endpoint. This information does not change over the lifetime of the endpoint. The host controller must not modify the bits in these DWords.

Table 15-42: USB Host QH DWords 1 and 2: Endpoint Capabilities and Characteristics

| Bits | Description |
|--|---|
| DWord 1: Capabilities and Characteristics. | |
| These are the USB endpoint characteristics including addressing, maximum packet size, and endpoint speed. | |
| 31:28 | NAK Count Reload, RL . This field contains a value, which is used by the host controller to reload the NAK Counter field. |
| 27 | Control Endpoint Flag, C . If the QH.EPS field indicates the endpoint is not a high speed device, and the endpoint is a control endpoint, then the HCD must set this bit to a 1. Otherwise, it should always set this bit to a 0. |
| 26:16 | Maximum Packet Length . This directly corresponds to the maximum packet size of the associated endpoint (wMaxPacketSize). The maximum value this field can contain is 400h (1,024). |
| 15 | Head of Reclamation List Flag, H . This bit is set by the HCD to mark a queue head as being the head of the reclamation list. |
| 14 | Data Toggle Control, DTC . This bit specifies where the host controller should get the initial data toggle on an overlay transition. <ul style="list-style-type: none"> 0: Ignore DT bit from incoming qTD. Host controller preserves DT bit in the queue head. 1: Initial data toggle comes from incoming qTD DT bit. Host controller replaces DT bit in the queue head from the DT bit in the qTD. |
| 13:12 | Endpoint Speed, EPS . Select speed of the associated endpoint. <ul style="list-style-type: none"> 00: Full-Speed (12 Mb/s) 01: Low-Speed (1.5 Mb/s) 10: High-Speed (480 Mb/s) 11: Reserved |
| 11:8 | Endpoint Number, EndPt . This 4-bit field selects the particular endpoint number on the device serving as the data source or sink. |
| 7 | Inactivate on Next Transaction, I . The HCD requests that the host controller set the Active status bit to 0. This field is only valid when the QH is in the Periodic Schedule and the QH.EPS field indicates an FS or LS endpoint. Setting this bit to a 1 when the queue head is in the Asynchronous Schedule or the QH.EPS field indicates a high-speed device yields undefined results. |
| 6:0 | Device Address . Select the specific device serving as the data source or sink. |
| DWord 2: Capabilities and Characteristics | |
| These are adjustable parameters of the endpoint. They affect how the endpoint data stream is managed by the host controller. | |
| 31:30 | High-Bandwidth Pipe Multiplier, Mult . This field is a multiplier used to key the host controller as the number of successive packets the host controller can submit to the endpoint in the current execution. The host controller makes the simplifying assumption that the HCD properly initializes this field (regardless of location of queue head in the schedules or other run time parameters). <ul style="list-style-type: none"> 00: Reserved. A 0 in this field yields undefined results. 01: One transaction to be issued for this endpoint per microframe. 10: Two transactions to be issued for this endpoint per microframe. 11: Three transactions to be issued for this endpoint per microframe. |

Table 15-42: USB Host QH DWords 1 and 2: Endpoint Capabilities and Characteristics (Cont'd)

| Bits | Description |
|-------|---|
| 29:23 | Port Number. This is used in the split-transaction protocol. This field is ignored by the host controller unless the QH.EPS field indicates a full- or low-speed device. The value is the port number identifier on the USB 2.0 Hub (for hub at device address Hub Addr below), below which the full- or low-speed device associated with this endpoint is attached. |
| 22:16 | Hub Address, Hub Addr. This field is used in the split-transaction protocol. This field is ignored by the host controller unless the QH.EPS field indicates a full- or low-speed device. The value is the USB device address of the USB 2.0 Hub below which the full- or low-speed device associated with this endpoint is attached. |
| 15:8 | Split Completion Mask, uFrame C-Mask. Refer to the text. |
| 7:0 | Interrupt Schedule Mask, uFrame S-mask. Refer to the text. |

uFrame C-Mask

The split completion mask field, QH.uFRAME C-Mask, is ignored by the host controller unless the QH.EPS field indicates this device is LS or FS and this QH is in the periodic list. This field (along with the Active and SplitX-state fields) is used to determine which microframes the host controller should execute a complete-split transaction. This field is a straight bit position field, so if bit [0] is set then the complete-split transaction should occur in the first microframe, if bit 1 is set then it should occur in the second microframe, and so on.

When the criteria for using this field are met, a 0 value in this field has undefined behavior. This field is used by the host controller to match against the three low-order bits of the FRINDEX register. If the FRINDEX register bits decode to a position where the QH.uFrame C-Mask field is a 1, then this queue head is a candidate for transaction execution. There can be more than one bit in this mask set.

The C-Mask can be set for multiple micro frames, as it is not known in which microframe the transaction will complete. So the C-Mask can be set for the micro frame after the S-Mask and all subsequent micro frames thereafter. The C-Mask field should not have a bit set to the same microframe as the S-Mask is set to.

uFrame S-mask

The interrupt schedule mask field, QH.uFrame S-mask, is used for all endpoint speeds. The HCD should set this field = 0 when the QH is on the asynchronous schedule. A non-zero value in this field indicates an interrupt endpoint.

The host controller uses the value of the three low-order bits of the FRINDEX register as an index into a bit position in this bit vector. If the QH.uFrame S-mask field has a 1 at the indexed bit position then this queue head is a candidate for transaction execution.

If the QH.EPS field indicates the endpoint is a high-speed endpoint, then the transaction executed is determined by the PID field contained in the execution area.

This field is also used to support split transaction types: Interrupt (IN/OUT). This condition is true when this field is non-zero and the QH.EPS field indicates this is either a full- or low-speed device.

A 0 value in this field, in combination with existing in the periodic frame list has undefined results. This field should have only one bit set to 1 at any given time. Having more than one bit set will result in undefined results.

QH DWord 3: Current qTD Pointer

The DWord 3 of a Queue Head contains a pointer to the source qTD currently associated with the overlay. The host controller uses this pointer to write back the overlay area into the source qTD after the transfer is complete.

Table 15-43: USB Host QH DWord 3

| Bits | Description |
|------|---|
| 31:5 | Current Element Transaction Descriptor Link Pointer. Current qTD Pointer. This field contains the address Of the current transaction being processed in this queue and corresponds to memory address signals [31:5]. |
| 4:0 | Reserved. Write 0. |

15.12.7 Transfer Overlay Area

The nine DWords in this area represent a transaction working space for the host controller. The general operational model is that the host controller can detect whether the overlay area contains a description of an active transfer. If it does not contain an active transfer, then it follows the Queue Head Horizontal Link Pointer to the next queue head. The host controller will never follow the Next Transfer Queue Element or Alternate Queue Element pointers unless it is actively attempting to advance the queue. For the duration of the transfer, the host controller keeps the incremental status of the transfer in the overlay area. When the transfer is complete, the results are written back to the original queue element.

Table 15-44: USB Host Transfer Overlay Descriptors

| Bits | Description | qTD DWord | QH DWord |
|-------------------------|---|-----------|----------|
| Next qTD Pointer | | 0 | 4 |
| 31:5 | Next qTD Pointer. This field contains the address of the next transaction being processed in this queue and corresponds to memory address signals [31:5], respectively. | | |
| 4:1 | Reserved. Write 0. | | |
| 0 | Terminate transfer, T . <ul style="list-style-type: none"> 0: link to the Next qTD Pointer field; the address is valid. 1: end the transaction, the Next qTD Pointer field is not valid. | | |

Table 15-44: USB Host Transfer Overlay Descriptors (Cont'd)

| Bits | Description | qTD DWord | QH DWord |
|-----------------------------------|--|-----------|----------|
| Alternate Next qTD Pointer | | | |
| 31:5 | Alternate Next qTD Pointer. | 1 | 5 |
| 4:1 | NAK Counter, NakCnt . This field is a counter the host controller decrements whenever a transaction for the endpoint associated with this queue head results in a Nak or Nyet response. This counter is reloaded from RL before a transaction is executed during the first pass of the reclamation list (relative to an Asynchronous List Restart condition). It is also loaded from RL during an overlay. | | |
| 0 | Terminate transfer, T . <ul style="list-style-type: none"> 0: link to the Alternate Next qTD Pointer field; the address is valid. 1: end the transaction, the Alternate Next qTD Pointer field is not valid. | | |
| Total Bytes | | | |
| 31 | Data toggle, DT . The Data Toggle Control controls whether the host controller preserves this bit when an overlay operation is performed. | 2 | 6 |
| 30:16 | Total Bytes . Refer to section Total Bytes to Transfer Parameter for more info. | | |
| 15 | Interrupt On Complete, IOC . The IOC control bit is always inherited from the source qTD when the overlay operation is performed. | | |
| 14:12 | C_Page . | | |
| 11:10 | Error Counter, Cerr . This two-bit field is copied from the qTD during the overlay and written back during queue advancement. | | |
| 9:8 | Port ID, PID . | | |
| 7:0 | Reserved. Write 0. | | |
| 0 | Ping State, /PERR . If the QH.EPS field indicates a high-speed endpoint, then this field should be preserved during the overlay operation. | | |
| Buffer Pointer (page 0) | | | |
| 31:12 | Buffer Pointer . 4KB aligned pointer to system memory address bits [31:12]. | 3 | 7 |
| 11:0 | Current Offset . | | |
| Buffer Pointer (page 1) | | | |
| 31:12 | Buffer Pointer . 4KB aligned pointer to system memory address bits [31:12]. | 4 | 8 |
| 11:8 | Reserved. | | |
| 7:0 | QH (split transactions only): C-prog-mask . qTD and non-split QH: Reserved . | | |
| Buffer Pointer (page 2) | | | |
| 31:12 | Buffer Pointer . 4KB aligned pointer to system memory address bits [31:12]. | 5 | 9 |
| 11:5 | S-bytes . This field is used to keep track of the number of bytes sent or received during an IN or OUT split transaction. The HCD must ensure that the S-bytes field in a qTD is 0 before activating the qTD. | | |
| 4:0 | Split-transaction Frame Tag, Split_Frame_Tag . This field is used to track the progress of an interrupt split-transaction. This field is initialized to 0 during any overlay. | | |

Table 15-44: USB Host Transfer Overlay Descriptors (Cont'd)

| Bits | Description | qTD DWord | QH DWord |
|---------------------------------------|---|-----------|-----------|
| Buffer Pointer (pages 3 and 4) | | 6 and 7 | 10 and 11 |
| 31:12 | Buffer Pointer. 4KB aligned pointer to system memory address bits [31:12]. | | |
| 11:0 | Reserved. | | |

15.12.8 Periodic Frame Span Traversal Node (FSTN)

This data structure is to be used only for managing Full- and Low-speed transactions that span a Host-frame boundary. The HCD must not use an FSTN in the Asynchronous Schedule. An FSTN in the Asynchronous schedule results in undefined behavior.

Table 15-45: USB Host Frame Span Traversal Node Descriptor (FSTN) Format

| Reference | Type | 31 | 30 | 29 | 28 | 27 | 26 | 25 | 24 | 23 | 22 | 21 | 20 | 19 | 18 | 17 | 16 | 15 | 14 | 13 | 12 | 11 | 10 | 9 | 8 | 7 | 6 | 5 | 4 | 3 | 2 | 1 | 0 | DWord |
|-------------|------|--------------------------|----|----|----|----|----|----|----|----|----|----|----|----|----|----|----|----|----|----|----|----|----|---|---|----|-----|---|---|---|---|---|---|-------|
| Table 15-46 | | Normal Path Link Pointer | | | | | | | | | | | | | | | | | | | | | | | | 00 | TYP | T | 0 | | | | | |
| Table 15-47 | | Back Path Link Pointer | | | | | | | | | | | | | | | | | | | | | | | | 00 | TYP | T | 1 | | | | | |

Host Controller Read-only

FSTN DWord 0: Normal Path Pointer

The first DWord of an FSTN contains a link pointer to the next schedule object. This object can be of any valid periodic schedule data type.

Table 15-46: USB Host FSTN DWord: Normal Path Pointer

| Bits | Description |
|------|--|
| 31:5 | Normal Path Link Pointer. Address of the next data object to be processed in the periodic list and corresponds to memory address bits [31:5], respectively. |
| 4:3 | Reserved. Field reserved and should be set to 0. |
| 2:1 | Transaction Descriptor Type, TYP . Set to 11 (FSTN type). Refer to section 15.12.2 Transfer Descriptor Type (TYP) Field for general information. |
| 0 | Terminate bit, T . <ul style="list-style-type: none"> 0: Link Pointer field points to a valid system memory offset from CTRLDSSEGMENT and the FSTN is a Save-Place indicator. 1: Link Pointer field is invalid and the FSTN is a Restore indicator. |

FSTN DWord 1: Back Path Link Pointer

The second DWord of an FSTN node contains a link pointer to a queue head. If the T-bit in this pointer is a 0, then this FSTN is a Save-Place indicator. Its TYP field must be set by the HCD to indicate the target data structure is a queue head. If the T-bit in this pointer is set to a 1, then this FSTN is the Restore indicator. When the T-bit is a 1, the host controller ignores the TYP field.

Table 15-47: USB Host FSTN DWord 1: Back Path Link Pointer

| Bits | Description |
|------|---|
| 31:5 | Back Path Link Pointer. This field contains the address of a Queue Head. This field corresponds to memory address signals [31:5], respectively. |
| 4:3 | Reserved. Field reserved and should be set to 0. |
| 2:1 | Transaction Descriptor Type, TYP. Set to 11 (FSTN type). Refer to section 15.12.2 Transfer Descriptor Type (TYP) Field for general information. |
| 0 | Terminate bit, T. <ul style="list-style-type: none"> 1: Link Pointer field is invalid and the FSTN is a Restore indicator. 0: Link Pointer field points to a valid system memory offset from CTRLDSSEGMENT and the FSTN is a Save-Place indicator. |

15.13 Programming Guide for Host Controller

The host controller driver software (HCD) provides a layered software architecture to control all aspects of a USB bus system. The HCD controls the functions of an embedded EHCI host controller. The USB driver layer provides all the USB driver functions to enumerate, manage and schedule a USB bus system, while the upper layers of the stack support standard USB device class interfaces to the device drives running on the embedded system.

15.13.1 Controller Reset

The controller has multiple types of resets, as described in section [15.15.2 Reset Types](#).

15.13.2 Run/Stop

When the HCD sets the usb.USBCMD [RS] bit = 1, the controller proceeds to the execute the periodic and asynchronous schedules. The controller continues execution as long as this bit is set to a 1. When this bit is set to 0, the host controller completes the current transaction on the USB and then halts. When the controller is finished with the transaction and has entered the stopped state, it writes a 1 to the usb USBSTS [HCH] bit. Software should not write a 1 to the [RS] bit to enable the controller unless the controller is in the Halted state, usb.USBSTS [HCH] bit = 1.

15.14 OTG Description and Reference

The register bits that are used for OTG operations are not reset when software writes a 1 to the usb.USBCMD [RST] reset bit. These bits are identified in [Table 15-1, page 414](#).

15.14.1 Hardware Assistance Features

The hardware assist mechanisms provide automated response and sequencing that might not be possible using software due to significant interrupt latency response times. The use of this additional circuitry is optional and can be used to assist the three sequences below.

- Auto-Reset [HAAR]: Reset after a connect event.
- Data-Pulse [HADP]: Generates a 7 ms pulse on the DP signal.
- B-Disconnect to A-Connect Event [HABA].

Auto-Reset Option

When the `usb.OTGSC [HAAR]` bit is set to 1, the host controller will automatically start a reset after a connect event. This shortcuts the normal process where the software is notified of the connect event and starts the reset. The software will still receive notification of the connect event but should not write the reset bit when the [HAAR] bit is set = 1. The software will be notified again after the reset is complete via the enable change bit in the `PORTSC1` register which cause a port change interrupt.

This hardware assistance feature will ensure the OTG parameter `TB_ACON_BSE0_MAX = 1 ms` is met.

Data-Pulse

Writing a 1 to `usb.OTGSC [HADP]` bit will start a data pulse of approximately 7 ms in duration and then automatically cease the data pulsing. During the data pulse, the DP signal will be set and then cleared. This automation relieves the software from accurately controlling the data-pulse duration. During the data pulse, the HCD can poll to see that the [HADP] and [DP] bits have returned low to recognize the completion or simply launch the data pulse and wait to see if a VBUS Valid interrupt occurs when the A-side supplies bus power.

This hardware assistance feature will ensure data pulsing meets the OTG requirement of > 5 ms and < 10 ms.

B-Disconnect to A-Connect

During HNP, the B-Disconnect occurs from the OTG `A_suspend` state and within 3 ms, the A-device must enable the pull-up on the DP signal in the A-peripheral state. When `usb.OTGSC [HABA]` is set = 1, the Host Controller port is in suspend mode, and the device disconnects, then this hardware assist begins.

1. Reset the OTG controller.
2. Set the OTG controller into device mode.
3. Write the device run bit to a 1 and enable necessary interrupts including:
4. USB Reset Enable [URE]; enables interrupt on USB bus reset to device
5. Sleep Enable [SLE]; enables interrupt on device suspend
6. Port Change Detect Enable [PCE]; enables interrupt on device connect

When the HCD has enabled this hardware assist, it must not interfere during the transition and should not write any control registers until it gets an interrupt from the device controller signifying that a reset interrupt has occurred or at least first verify that the controller has entered device mode. The HCD must not activate the soft reset at any time since this action is performed by hardware. During the transition, the HCD might see an interrupt from the disconnect and/or other spurious interrupts (i.e., SOF/etc.) that might or might not cascade and can be cleared by the soft reset depending on the HCD response time.

After the controller has entered device mode by the hardware assist, the HCD must ensure that the usb.ENDPTLISTADDR is programmed properly before the host sends a setup packet. Since the end of the reset duration, which can be initiated quickly (a few microseconds) after connect, will require at a minimum 50 ms, this is the time for which the HCD must be ready to accept setup packets after having received notification that the reset has been detected or simply that the OTG is in device mode whichever occurs first.

In the case where the A-peripheral fails to see a reset after the controller enters device mode and engages the DP-pull-up, the interrupt software signifying that a suspend has occurred.

This assist will ensure the parameter TA_BDIS_ACON_MAX = 3 ms is met.

15.14.2 OTG Interrupt and Control Bits

The interrupt and control bits are included in one register, the OTGSC register. Changes in the status activity will latched events. The status bits indicate the current activity. Software reads the latched events and status activity bits to determine there was an event and its status. The IRQ interrupt signal to the GIC interrupt controller will be asserted to the GIC interrupt controller when both the interrupt enable bit (controlled by software) and the associated status activity bit (controlled by hardware) are equal to 1.

Table 15-48: USB OTG Status/Interrupt and Control Bits in the OTGSC Register

| Interrupts | | | | | | | | | | | | | Control Bits | | | | | | | | | | | | | | | | | | |
|--|--------------|----|----|----|----|----|----|---------------------|----|----|----|----|--------------|------|--------------------|-----------------|-----------------|--------|--------|--|----|------|------|------|----|----|------|----|----|---|---|
| 31 | 30 | 29 | 28 | 27 | 26 | 25 | 24 | 23 | 22 | 21 | 20 | 19 | 18 | 17 | 16 | 15 | 14 | 13 | 12 | 11 | 10 | 9 | 8 | 7 | 6 | 5 | 4 | 3 | 2 | 1 | 0 |
| r | Enable (R/W) | | | | | | r | Latched Event (W1C) | | | | | | r | Status (read-only) | | | | | | | HABA | HADP | IDPU | DP | OT | HAAR | VC | VD | | |
| Interrupts: <ul style="list-style-type: none"> Status Activity Latched Events Interrupt Enable | | | | | | | | | | | | | Data Pulse | 1 ms | B Session End | B Session Valid | A Session Valid | A VBus | USB ID | 0: VD: Vbus Discharge enable (rw) 1: VC: VBus Charge enable (rw) 2: HAAR: Hardware Auto-Reset enable (rw) 3: OT: OTG Device mode DP M pull-down enable (rw) 4: DP: Assert DP pull-up during SRP (rw) 5: IDPU: ID Pull-up enable (rw) 6: HADP: Hardware Assist Data-pulse generator (rw) 7: HABA: Hardware Assist B-disconnect to A-connect (rw) | | | | | | | | | | | |

15.15 System Functions

The system functions include clocks, resets, memory interfaces and system interrupts.

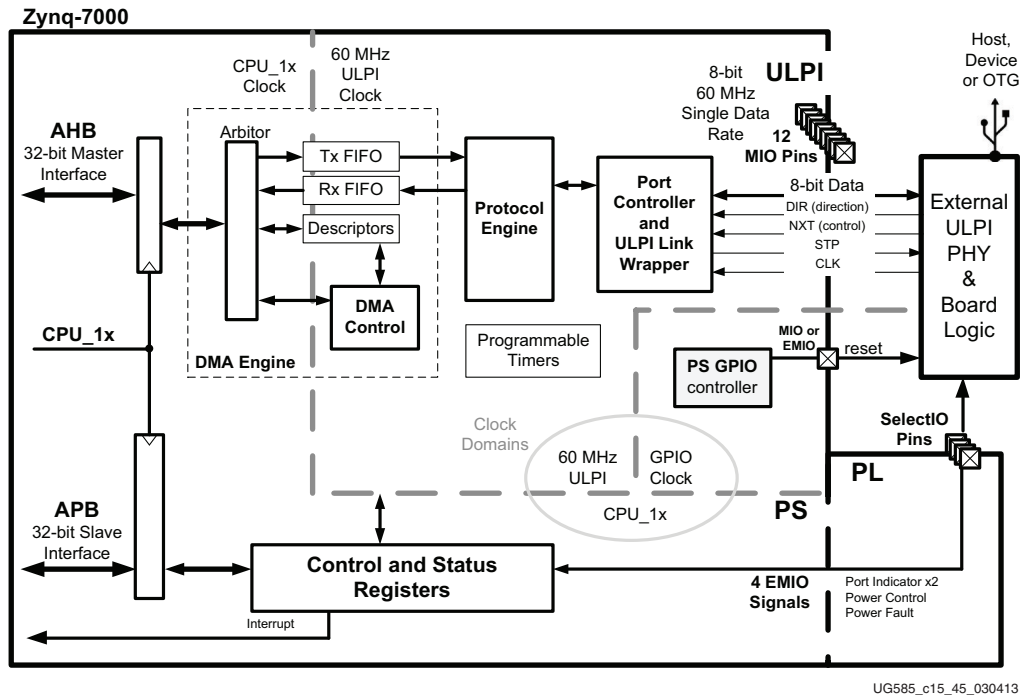

Figure 15-18: USB Detailed System Block Diagram

15.15.1 Clocks

The vast majority of the controller logic is driven by the 60 MHz clock from the ULPI PHY. The controller's interconnect is driven by the AHB/APB interface CPU_1x clock which is generated by the PS clock subsystem.

CPU_1x Clock

Refer to section 25.3 [System-wide Clock Frequency Examples](#), for general clock programming information. The CPU_1x clock runs asynchronous to the 60 MHz PHY Clock.



IMPORTANT: The frequency of the CPU_1x clock must be set higher than the 60 MHz ULPI clock from the external PHY.

60 MHz PHY Clock

The external PHY provides a 60 MHz clock that the ULPI is sync'd to and is used by the a majority of the controller logic.

15.15.2 Reset Types

To reset the controller, software writes a 1 to the `usb.USBCMD [RST]` bit. When the reset process is completed, the controller hardware sets this bit to 0. Once the reset is started, the controller cannot stop the process. Writing a 0 has no effect.

When software writes a 1 to this bit, the Controller resets its internal pipelines, timers, counters, and state machines to their initial value. Any transaction currently in progress on USB is immediately terminated. A USB reset is not driven to downstream ports. Software should not set this bit to a 1 when the host controller halt bit, `usb.USBSTS [HCH]`, = 0. Attempting to reset an actively running host controller will result in undefined behavior.

Controller Resets

- PS Reset System (full controller reset),
- `usb.USBCMD [RST]` bit (partial controller reset useful for OTG).
- OTG Mode Auto-Reset

ULPI PHY Reset

The USB controller does not have a reset output for the ULPI PHY. If the PHY requires a reset, then, a PS or PL GPIO (or other software controlled reset signal) must be connected to the PHY as shown in [Figure 15-19, page 482](#).

Note: The ULPI PHY reset signal is not required for all applications.

USB Bus Reset

The host controller generates the standard USB reset as described in the EHCI specification. The optional light host reset is not supported. The response by the device controller is described in section [15.4.2 USB Bus Reset Response](#).

Summary of Resets

The controller has multiple reset sources and multiple reset domains. These are summarized in [Table 15-49 USB Resets Summary List](#).

Table 15-49: USB Resets Summary List

| Reset Name | Controller State | Registers | IRQ | Reference |
|--|------------------|-----------|-------|--|
| PS System Reset AMBA (APB/AHB) Interface Reset slcr.USB_RST_CTRL [USBx_CPU1X_RST] | Yes | Yes | no | Chapter 26, Reset System. Reset values: Appendix B, Register Details. |
| usb.USBCMD [RST] (partial controller reset) | | Partial | no | Device and Host Modes |
| OTG mode Auto-Reset Hardware Assistance usb.USBOTG [HAAR] | | | no | Section 15.14.1 Hardware Assistance Features |
| PHY reset Output from PS GPIO controller | no effect | no effect | no | Chapter 15, USB Host, Device, and OTG Controller |
| Send USB Reset (Host Mode) | no effect | no effect | no | Software Example. |
| Receive USB Reset (Device Mode) | no effect | no effect | [URI] | Software Example. |

15.15.3 System Interrupt

Each controller sends its own IRQ interrupt to the GIC interrupt controller and to the EMIO interface based on events within the controller. Controller 0 generates IRQ #53 and controller 1 generates IRQ #76. These are shown in more detail in section [7.2.3 Shared Peripheral Interrupts \(SPI\)](#).

The individual host and device mode interrupts can be read and cleared using the usb.USBSTS register and masked using the usb.USBINTR register. These interrupts are described in section [15.3.5 Interrupt and Status Bits Overview](#).

The individual OTG interrupts are contained in the usb.OTGSC register and described in section [15.14.2 OTG Interrupt and Control Bits](#).

15.15.4 APB Slave Interface

The 32-bit APB slave interface is used by the software to read and write the control and status registers. The interface is AMBA 3.0 compatible. All signals are used except PRESET_N and PSLVERR.

15.15.5 AHB Master Interface

The 32-bit AHB master interface is used by the DMA controller to read and write data packets and transfer descriptors. The interface is AMBA 3.0 compatible.

Unused Signals

All of the AHB interface signals are used except:

- PROT[3:0] are tied to 0001 (non-cacheable transactions).

15.16 I/O Interfaces

The controller has multiple I/O interfaces including the main ULPI that interfaces via MIO to the external PHY and the port indicator and power signals via EMIO. The routing of the ULPI through the MIO must be programmed. The routing of the signals through the EMIO is always available to logic in the PL that can route these signals to the SelectIO pins.

15.16.1 Wiring Connections

The wiring connections for both MIO and EMIO are shown in [Figure 15-19](#).

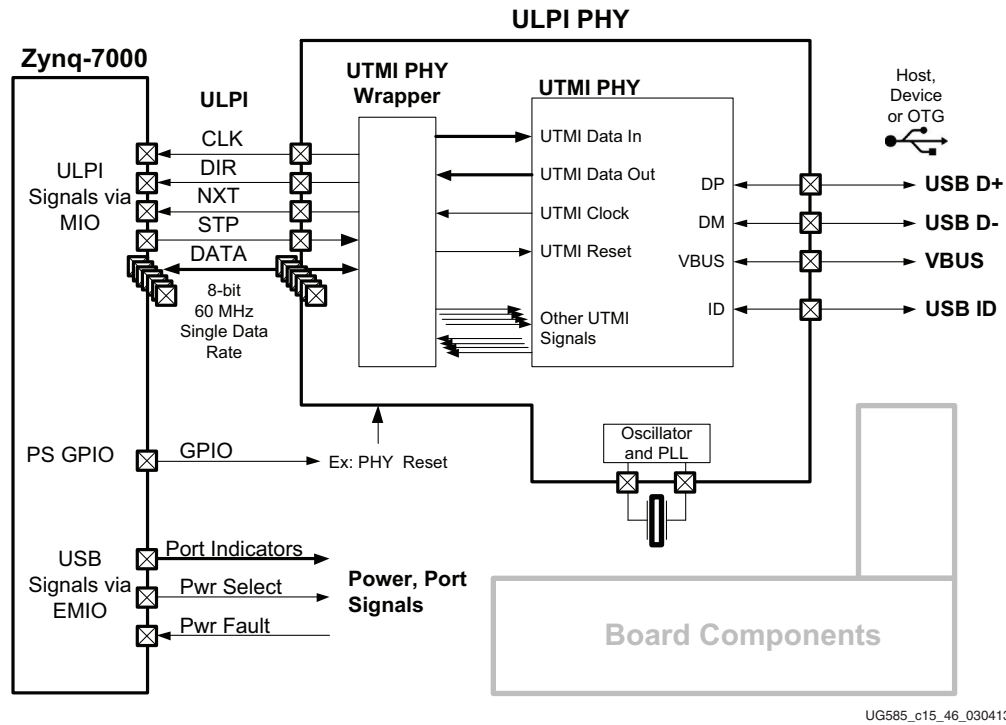

UG585_c15_46_030413

Figure 15-19: USB I/O Signal and PHY Wiring Diagram

15.16.2 MIO-EMIO Programming

MIO Pins

The ULPI signals from each controller are routed to specific MIO pins. In this chapter, refer to [Table 15-50 USB ULPI Signals on MIO](#). A wiring diagram is shown in [Figure 15-19, page 482](#).

The general routing concepts and MIO I/O buffer configurations are explained in section [2.5 PS-PL MIO-EMIO Signals and Interfaces](#). A summary of the MIO pins is shown in section [2.5.4 MIO-at-a-Glance Table](#).

Example: Program I/O for Controller 1

These steps configure the USB controller 1 onto MIO pins 40 to 51.

1. **Configure MIO pins 40, 44 - 47 and 49 -51 for data I/O.** Write to the associated slcr registers, MIO_PIN_{40, 44-47}:
 - a. Route USB ULPI data signal to I/O buffer.
 - b. 3-state controlled by USB controller (TRI_ENABLE = 0).
 - c. LVCMOS18 (refer to the register definition for other voltage options).
 - d. Slow CMOS edge.
 - e. Disable internal pull-up resistor.
 - f. Disable HSTL receiver.
2. **Configure MIO pins 41, 43, and 48 for input.** Write to each of the slcr.MIO_PIN_{48, 43, 41} registers:
 - a. Route USB ULPI input signals DIR to pin 41, STP to pin 43 and CLK to pin 48.
 - b. Disable output (TRI_ENABLE = 1).
 - c. LVCMOS18 (refer to the register definition for other voltage options).
 - d. Slow CMOS drive edge (benign setting).
 - e. Disable internal pull-up resistor.
 - f. Disable HSTL receiver.
3. **Configure MIO pin 42 for output.** Write to the slcr.MIO_PIN_42 register:
 - a. Route USB ULPI output signal STP to pin 42.
 - b. 3-state controlled by USB Controller (TRI_ENABLE = 0).
 - c. LVCMOS18 (refer to the register definition for other voltage options).
 - d. Slow CMOS edge.
 - e. Disable internal pull-up resistor.
 - f. Disable HSTL receiver.

15.16.3 MIO-EMIO Signals

The ULPI interface signals are listed in [Table 15-50](#). The port indicator and power signals are shown in [Table 15-51](#).

The 7z010 dual core and 7z007s single core CLG225 devices support 32 MIO pins. Pin restrictions are shown in the MIO table in section [2.5.4 MIO-at-a-Glance Table](#).

Table 15-50: USB ULPI Signals on MIO

| USB Port Signals | MIO Pins | | | | Default Input Value to Controller |
|-----------------------------------|----------|-------|-----|---------------------|-----------------------------------|
| | USB 0 | USB 1 | I/O | Name | |
| Transmit and receive data 4 | 28 | 40 | IO | USB{0,1}_ULPI_DATA4 | ~ |
| Data bus direction control | 29 | 41 | I | USB{0,1}_ULPI_DIR | 0 |
| Stop the Transfer (end/interrupt) | 30 | 42 | O | USB{0,1}_ULPI_STP | ~ |
| Data flow control signal | 31 | 43 | I | USB{0,1}_ULPI_NXT | 0 |
| Transmit and receive data 0 | 32 | 44 | IO | USB{0,1}_ULPI_DATA0 | ~ |
| Transmit and receive data 1 | 33 | 45 | IO | USB{0,1}_ULPI_DATA1 | ~ |
| Transmit and receive data 2 | 34 | 46 | IO | USB{0,1}_ULPI_DATA2 | ~ |
| Transmit and receive data 3 | 35 | 47 | IO | USB{0,1}_ULPI_DATA3 | ~ |
| Transceiver clock for ULPI | 36 | 48 | I | USB{0,1}_ULPI_CLK | 0 |
| Transmit and receive data 5 | 37 | 49 | IO | USB{0,1}_ULPI_DATA5 | ~ |
| Transmit and receive data 6 | 38 | 50 | IO | USB{0,1}_ULPI_DATA6 | ~ |
| Transmit and receive data 7 | 39 | 51 | IO | USB{0,1}_ULPI_DATA7 | ~ |

Note: ULPI PHY reset signal is not required for all applications.

Table 15-51: USB Port Indicator and Power Signals on EMIO

| USB Port Signals | EMIO Signals | | Default Input Value to Controller |
|------------------|-----------------------------|-----|-----------------------------------|
| | Name | I/O | |
| Port Indicator | EMIOUSB{0,1}PORTINDCTL{0,1} | O | ~ |
| Power Fault | EMIOUSB{0,1}VBUSPWRFAULT | I | 0 |
| Power Select | EMIOUSB{0,1}VBUSPWRSELECT | O | ~ |

Gigabit Ethernet Controller

16.1 Introduction

The Gigabit Ethernet Controller (GEM) implements a 10/100/1000 Mb/s Ethernet MAC compatible with the IEEE 802.3-2008 standard capable of operating in either half or full duplex mode at all three speeds. The PS is equipped with two Gigabit Ethernet Controllers. Each controller can be configured independently. To access pins via MIO, each controller uses an RGMII interface (to save pins). Access to the PL is through the EMIO which provides the GMII interface.

Other Ethernet communications interfaces can be created in the PL using the GMII available on the EMIO interface. For example, the PL can be used to implement these interfaces:

- SGMII and 1000 Base-X, in devices with GTX
- RGMII v2.0 for PHY devices with HSTL Class 1 drivers and receivers

Registers are used to configure the features of the MAC, select different modes of operation, and enable and monitor network management statistics. The DMA controller connects to memory through an AHB bus interface. It is attached to the controller's FIFO interface of the MAC to provide a scatter-gather type capability for packet data storage in an embedded processing system.

The controllers provide MDIO interfaces for PHY management. The PHYs can be controlled from either of the MDIO interfaces.

16.1.1 Block Diagram

A block diagram of one Ethernet controller is shown in Figure 16-1.

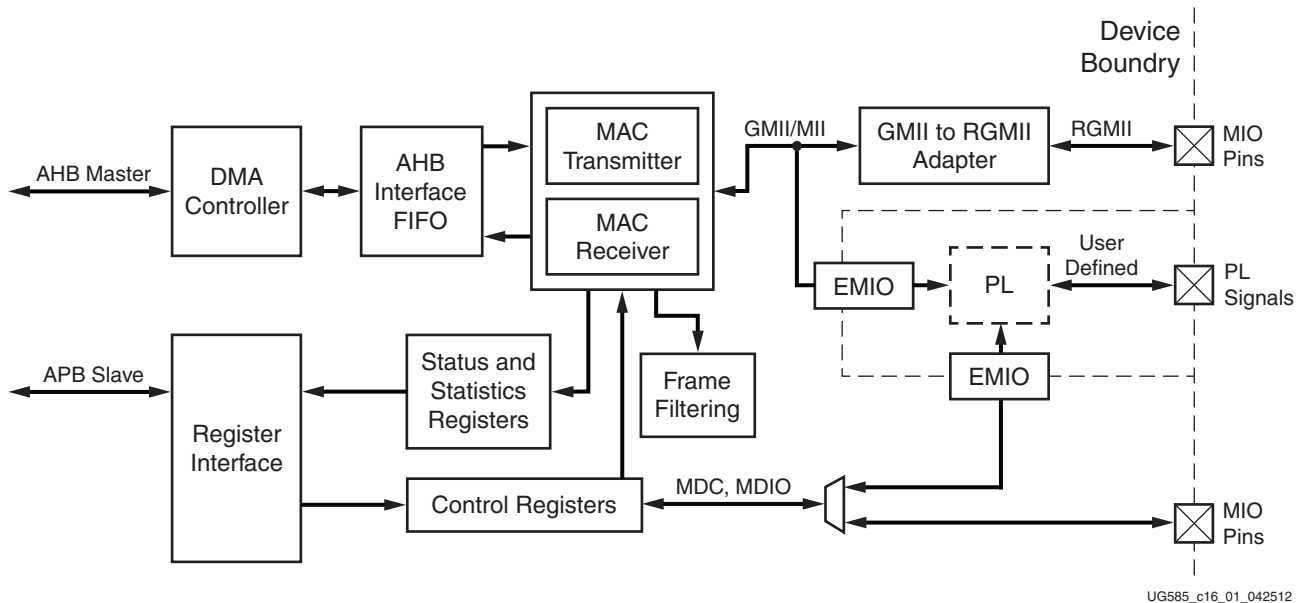

Figure 16-1: Ethernet Controller

16.1.2 Features

Each Gigabit Ethernet MAC controller has the following features:

- IEEE Standard 802.3-2008 compatible, supporting 10/100/1000 Mb/s transfer rates
- Full and half duplex operation
- RGMII interface with external PHY when using MIO pins
- GMII/MII interface to the PL to allow connection of interfaces such as TBI, SGMII, 1000 Base-X and RGMII v2.0 support using soft cores (Note: SGMII and 1000 Base-X interfaces require a gigabit transceiver, MGT)
- MDIO interface for physical layer management
- 32-bit AHB DMA master, 32-bit APB bus for control registers access
- Scatter-gather DMA capability
- Interrupt generation to signal receive and transmit completion, or errors and wake-up
- Automatic pad and cyclic redundancy check (CRC) generation on transmitted frames
- Automatic discard of frames received with errors
- Programmable IPG stretch
- Full duplex flow control with recognition of incoming pause frames and hardware generation of transmitted pause frames

- Address checking logic for four specific 48-bit addresses, four type ID values, promiscuous mode, hash matching of unicast and multicast destination addresses and Wake-on-LAN
- 802.1Q VLAN tagging with recognition of incoming VLAN and priority tagged frames
- Supports Ethernet loopback mode
- IPv4 and IPv6 transmit and receive IP, TCP and UDP checksum offload
- Statistics counter registers for RMON/MIB

16.1.3 System Viewpoint

Figure 16-2 shows Zynq system viewpoint for the Gigabit Ethernet controllers.

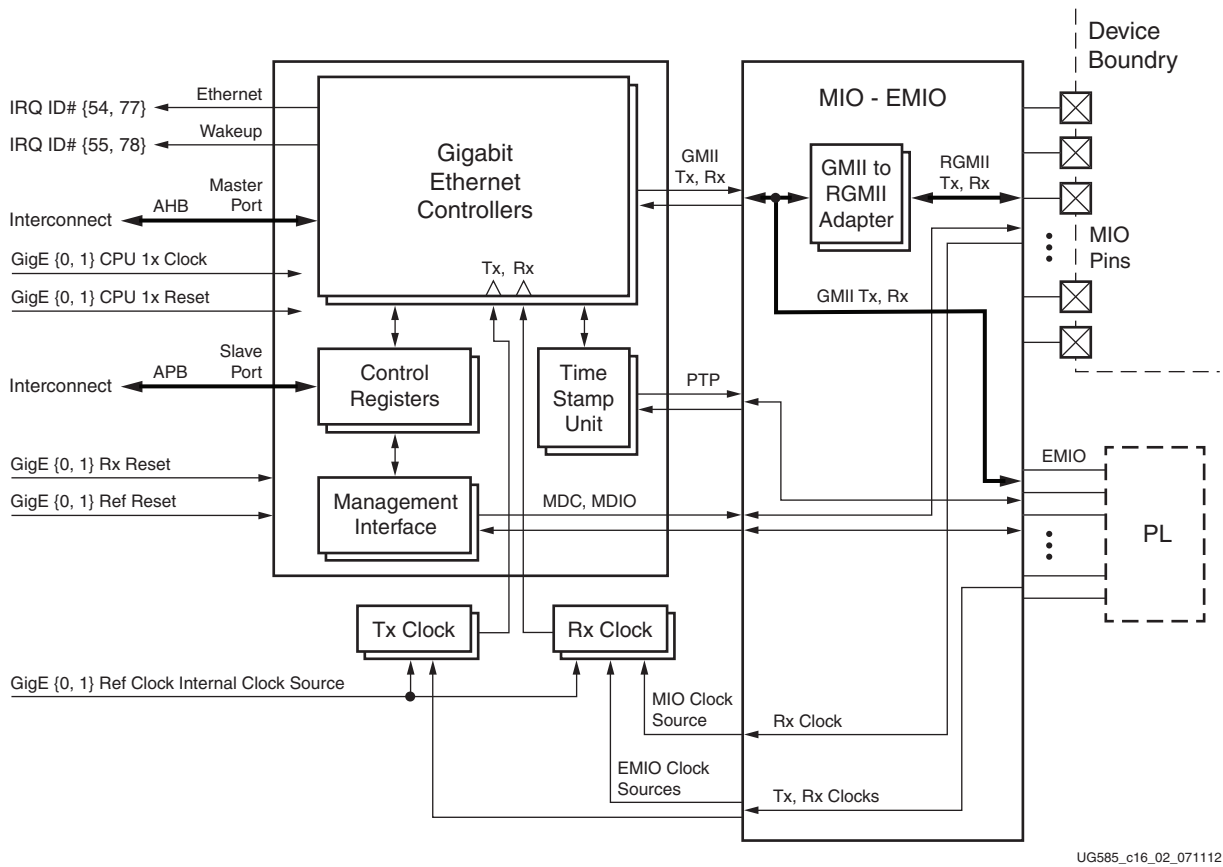

Figure 16-2: System Viewpoint

UG585_c16_02_071112

16.1.4 Clock Domains

The Gigabit Ethernet controller has the following clocks:

- AHB clock: AHB clock used by DMA block
- APB clock: APB clock used by MAC register block
- TSU clock: Alternate clock source for the Time Stamp Unit
- TX clock: MAC transmit clock used by MAC transmit block in MII/RGMII/GMII mode
- Rx clock: MAC receive clock used MAC receive synchronisation in MII/RGMII/GMII mode
- Invert TX clock: Inverted Tx clock used in loop back mode

Refer to [Table 24-2, page 671](#) for the more details about power management. Refer to [Chapter 25, Clocks](#) for details about the clocks.

16.1.5 Notices

7z007s and 7z010 CLG225 Devices

The 7z007s single core and 7z010 dual core CLG225 devices support 32 MIO pins and at most one Ethernet interface through the MIO pins. This is shown in the MIO table in section [2.5.4 MIO-at-a-Glance Table](#). One or both of the Ethernet controllers can interface to logic in the PL. All of these CLG225 device restrictions are listed in section [1.1.3 Notices](#).

Jumbo Frames

Jumbo frames are not supported.

Half Duplex

Gigabit Half Duplex is not supported.

16.1.6 Application Notes

There are two useful application notes, [XAPP1026](#) for standalone/lwip applications and [XAPP1082](#) for Linux. These application notes include benchmark performance values and other helpful information.

16.2 Functional Description and Programming Model

The controller comprises four main components:

- MAC controlling transmit, receive, address checking, and loopback
- Control and status registers, statistics registers, and synchronization logic
- DMA controlling data transmit and receive through an AHB master interface

10/100/1000 Operation

The gigabit enable bit in the Network Configuration register selects between 10/100 Mb/s Ethernet operation and 1000 Mb/s mode. The 10/100 Mb/s speed bit in the network configuration register is used to select between 10 Mb/s and 100 Mb/s.

MDIO Interface

Both controllers provide MDIO interfaces, however, only one interface is needed to control both of the external PHYs due to the difference in PHY address.

16.2.1 MAC Transmitter

The MAC transmitter can operate in either half duplex or full duplex mode, and transmits frames in accordance with the Ethernet IEEE 802.3 standard. In half duplex mode, the CSMA/CD protocol of the IEEE 802.3 specification is followed.

Frame assembly starts by adding the preamble and the start frame delimiter. Data is taken from the transmit FIFO a word at a time. When the controller is configured for gigabit operation, the data output to the PHY uses all eight bits of the txd[7:0] output. In 10/100 mode, transmit data to the PHY is nibble wide and least significant nibble first using txd[3:0] with txd[7:4] tied to logic 0.

If necessary, padding is added to take the frame length to 60 bytes. CRC is calculated using an order 32 bit polynomial. This is inverted and appended to the end of the frame taking the frame length to a minimum of 64 bytes. If the no-CRC bit is set in the second word of the last buffer descriptor of a transmit frame, neither pad nor CRC are appended. The no-CRC bit can also be set through the FIFO.

In full duplex mode (at all data rates), frames are transmitted immediately. Back-to-back frames are transmitted at least 96 bit times apart to guarantee the interframe gap.

In half duplex mode, the transmitter checks carrier sense. If asserted, the transmitter waits for the signal to become inactive, and then starts transmission after the interframe gap of 96 bit times. If the collision signal is asserted during transmission, the transmitter transmits a jam sequence of 32 bits taken from the data register and then retries transmission after the back off time has elapsed. If the collision occurs during either the preamble or SFD, then these fields are completed prior to generation of the jam sequence.

The back off time is based on an XOR of the 10 least significant bits of the data coming from the transmit FIFO and a 10-bit pseudo random number generator. The number of bits used depends on the number of collisions seen. After the first collision 1 bit is used, then the second 2 bits and so on up to the maximum of 10 bits. All 10 bits are used above ten collisions. An error is indicated and no further attempts are made if 16 consecutive attempts cause a collision. This operation is compatible with the description in *Clause 4.2.3.2.5 of the IEEE 802.3 standard* which refers to the truncated binary exponential back off algorithm.

In 10/100 mode, both collisions and late collisions are treated identically, and back off and retry are performed up to 16 times. When operating in gigabit mode, late collisions are treated as an exception and transmission is aborted, without retry. This condition is reported in the transmit buffer descriptor word 1 (late collision, bit 26) and also in the Transmit Status register (late collision, bit 7). An interrupt can also be generated (if enabled) when this exception occurs, and bit 5 in the Interrupt Status Register is set.

When bit [28] is set in the Network Configuration register the IPG can be stretched beyond 96 bits depending on the length of the previously transmitted frame and the value written to the IPG_STRETCH register. The least significant 8 bits of the IPG_STRETCH register multiply the previous frame length (including preamble) the next significant 8 bits (+1 so as not to get a divide by zero) divide the frame length to generate the IPG. IPG stretch only works in full duplex mode and when bit 28 is set in the Network Configuration register. The IPG_STRETCH register cannot be used to shrink the IPG below 96 bits.

If the back pressure bit is set in the Network Control register or if the half_duplex_flow_control_en input is set in 10M or 100M half duplex mode, the transmit block transmits 64 bits of data, which can consist of 16 nibbles of 1011 or in bit rate mode 64 1s, whenever it sees an incoming frame to force a collision. This provides a way of implementing flow control in half duplex mode.

16.2.2 MAC Receiver

All processing within the MAC receiver uses 16-bit data paths. The MAC receiver checks for valid preamble, FCS, alignment, and length. It then sends the received frames to the FIFO (to either the DMA controller or external to the IP core) and stores the frames destination address for use by the address checking block.

If, during frame reception, the frame is found to be too long, a bad frame indication is sent to the FIFO. The receiver logic ceases to send data to memory as soon as this condition occurs.

At end of frame reception the receive block indicates to the DMA block whether the frame is good or bad. The DMA block recovers the current receive buffer if the frame was bad.

Ethernet frames are normally stored in DMA memory or to the FIFO complete with the FCS. Setting the FCS remove bit in the network configuration register (bit [17]) causes frames to be stored without their corresponding FCS. The reported frame length field is reduced by four bytes to reflect this operation.

The receive block signals to the register block to increment the alignment, CRC (FCS), short frame, long frame, jabber or receive symbol errors when any of these exception conditions occur.

If bit [26] is set in the network configuration CRC errors are ignored and frames with CRC errors are not discarded, though the Frame Check Sequence Errors Statistic register is still incremented. Bit[13]

of the receiver descriptor word 1 is updated to indicate the FCS validity for the particular frame. This is useful for applications where individual frames with FCS errors must be identified.

Received frames can be checked for length field error by setting the length field error frame discard bit of the Network Configuration register (bit [16]). When this bit is set, the receiver compares a frame's measured length with the length field (bytes 13 and 14) extracted from the frame. The frame is discarded if the measured length is shorter. This checking procedure is for received frames between 64 bytes and 1,518 bytes in length.

Each discarded frame is counted in the 10-bit length field Error Statistics register. Frames where the length field is greater than or equal to 0x0600 are not checked.

16.2.3 MAC Filtering

The MAC filter determines which frames should be written to the AHB interface FIFO and onto the DMA controller.

Whether a frame is passed depends on what is enabled in the Network Configuration register, the state of the external matching pins, the contents of the specific address, type, and hash registers and the frame's destination address and type field.

If bit [25] of the Network Configuration register is not set, a frame is not copied to memory if the Gigabit Ethernet controller is transmitting in half duplex mode at the time a destination address is received.

Ethernet frames are transmitted a byte at a time, least significant bit first. The first six bytes (48 bits) of an Ethernet frame make up the destination address. The first bit of the destination address, which is the LSB of the first byte of the frame, is the group or individual bit. This is one for multicast addresses and zero for unicast. The all-ones address is the broadcast address and a special case of multicast.

The Gigabit Ethernet controller supports recognition of four specific addresses. Each specific address requires two registers, Specific Address register bottom and Specific Address register top. Specific address register bottom stores the first four bytes of the destination address and Specific Address register top contains the last two bytes. The addresses stored can be specific, group, local or universal.

The destination address of received frames is compared against the data stored in the Specific Address registers once they have been activated. The addresses are deactivated at reset or when their corresponding Specific Address register bottom is written. They are activated when Specific Address register top is written. If a receive frame address matches an active address, the frame is written to the FIFO and on to DMA controller, if used.

Frames can be filtered using the type ID field for matching. Four type ID registers exist in the register address space and each can be enabled for matching by writing a one to the MSB (bit [31]) of the respective register. When a frame is received, the matching is implemented as an OR function of the various types of match.

The contents of each type ID registers (when enabled) are compared against the length/type ID of the frame being received (e.g., bytes 13 and 14 in non-VLAN and non-SNAP encapsulated frames) and copied to memory if a match is found. The encoded type ID match bits (Word 0, bit [22] and bit

[23]) in the receive buffer descriptor status are set indicating which type ID register generated the match, if the receive checksum offload is disabled. The reset state of the type ID registers is zero, hence each is initially disabled.

The Address and Type ID filtering are independent of each other. If both the Specific Address registers and Type ID Match registers are set up, then the received frame will be written into the system memory for either an address match or a ID match.

The following example illustrates the use of the address and type ID match registers for a MAC address of 21:43:65:87:A9:CB

| | |
|--------------------|-----|
| Preamble | 55 |
| SFD | D5 |
| DA (Octet 0 - LSB) | 21 |
| DA (Octet 1) | 43 |
| DA (Octet 2) | 65 |
| DA (Octet 3) | 87 |
| DA (Octet 4) | A9 |
| DA (Octet 5 - MSB) | CB |
| SA (LSB) | 00* |
| SA | 00* |
| SA | 00* |
| SA | 00* |
| SA | 00* |
| SA (MSB) | 00* |
| Type ID (MSB) | 43 |
| Type ID (LSB) | 21 |

Note: * – contains the address of the transmitting device.

The sequence above shows the beginning of an Ethernet frame. Byte order of transmission is from top to bottom as shown. For a successful match to specific address 1, the following address matching registers must be set up:

| | |
|---|------------|
| Specific address 1 bottom (Address 0x088) | 0x87654321 |
| Specific address 1 top (Address 0x08C) | 0x0000CBA9 |

And for a successful match to the type ID, the following type ID match 1 register must be set up:

| | |
|---------------------------------|------------|
| Type ID Match 1 (Address 0x0A8) | 0x80004321 |
|---------------------------------|------------|

Broadcast Address

Frames with the broadcast address of 0xFFFFFFFFFFFF are stored to memory only if the 'no broadcast' bit in the Network Configuration register is set to zero.

Hash Addressing

The Hash Address register is 64 bits long and takes up two locations in the memory map. The least significant bits are stored in Hash register bottom and the most significant bits in Hash register top.

The unicast hash enable and the multicast hash enable bits in the Network Configuration register enable the reception of hash matched frames. The destination address is reduced to a 6 bit index into

the 64 bit hash register using the following hash function. The hash function is an XOR of every sixth bit of the destination address.

```

hash_index[05] = da[05]^da[11]^da[17]^da[23]^da[29]^da[35]^da[41]^da[47]
hash_index[04] = da[04]^da[10]^da[16]^da[22]^da[28]^da[34]^da[40]^da[46]
hash_index[03] = da[03]^da[09]^da[15]^da[21]^da[27]^da[33]^da[39]^da[45]
hash_index[02] = da[02]^da[08]^da[14]^da[20]^da[26]^da[32]^da[38]^da[44]
hash_index[01] = da[01]^da[07]^da[13]^da[19]^da[25]^da[31]^da[37]^da[43]
hash_index[00] = da[00]^da[06]^da[12]^da[18]^da[24]^da[30]^da[36]^da[42]
    
```

da[0] represents the least significant bit of the first byte received, that is, the multicast/unicast indicator, and da[47] represents the most significant bit of the last byte received.

If the hash index points to a bit that is set in the Hash register then the frame is matched according to whether the frame is multicast or unicast.

A multicast match is signaled if the multicast hash enable bit is set, da[0] is logic 1 and the hash index points to a bit set in the Hash register. A unicast match is signaled if the unicast hash enable bit is set, da[0] is logic 0 and the hash index points to a bit set in the Hash register. To receive all multicast frames, the Hash register should be set with all ones and the multicast hash enable bit should be set in the Network Configuration register.

Copy All Frames (or Promiscuous Mode)

If the copy all frames bit is set in the Network Configuration register then all frames (except those that are too long, too short, have FCS errors, or have rx_er asserted during reception) are copied to memory. Frames with FCS errors are copied if bit [26] is set in the Network Configuration register.

Disable Copy of Pause Frames

Pause frames can be prevented from being written to memory by setting the disable copying of pause frames control bit [23] in the Network Configuration register. When set, pause frames are not copied to memory regardless of the copy all frames bit, whether a hash match is found, a type ID match is identified, or if a destination address match is found.

VLAN Support

An Ethernet encoded 802.1Q VLAN tag is shown in [Table 16-1](#)

Table 16-1: VLAN Tag Control Information

| TPID (Tag Protocol Identifier) 16 Bits | TCI (Tag Control Information) 16 Bits |
|--|---|
| 0x8100 | First 3 bits priority, then CFI bit, last 12 bits VID |

The VLAN tag is inserted at the 13th byte of the frame adding an extra four bytes to the frame. To support these extra four bytes, the Gigabit Ethernet controller can accept frame lengths up to 1,536 bytes by setting bit [8] in the Network Configuration register.

If the VID (VLAN identifier) is null (0x000) a priority-tagged frame is indicated.

The following bits in the receive buffer descriptor status word provide information about VLAN tagged frames:

- Bit [21] set if receive frame is VLAN tagged (i.e. type id of 0x8100).
- Bit [20] set if receive frame is priority tagged (i.e. type id of 0x8100 and null VID). (If bit [20] is set bit [21] is also set).
- Bits [19], [18] and [17] set to priority if bit [21] is set.
- Bit [16] set to CFI if bit [21] is set.

The controller can be configured to reject all frames except VLAN tagged frames by setting the discard non-VLAN frames bit in the Network Configuration register.

16.2.4 Wake-on-LAN Support

The receive block supports Wake-on-LAN by detecting the following events on incoming receive frames:

- Magic packet
- ARP request to the device IP address
- Specific address 1 filter match
- Multicast hash filter match

If one of these events occurs, Wake-on-LAN detection is indicated by asserting the wake-up interrupt. These events can be individually enabled through bits[19:16] of the Wake-on-LAN register. Also, for Wake-on-LAN detection to occur receive enable must be set in the Network Control register, however a receive buffer does not have to be available.

The wake-up interrupt is asserted due to multicast filter events, an ARP request, or a specific address 1 match even in the presence of a frame error. For magic packet events, the frame must be correctly formed and error free.

A magic packet event is detected if all of the following are true:

- Magic packet events are enabled through bit [16] of the Wake-on-LAN register
- The frame's destination address matches specific address 1
- The frame is correctly formed with no errors
- The frame contains at least 6 bytes of 0xFF for synchronization
- There are 16 repetitions of the contents of Specific Address 1 register immediately following the synchronization

An ARP request event is detected if all of the following are true:

- ARP request events are enabled through bit [17] of the Wake-on-LAN register
- Broadcasts are allowed by bit 5 in the Network Configuration register
- The frame has a broadcast destination address (bytes 1 to 6)

- The frame has a typeID field of 0x0806 (bytes 13 and 14)
- The frame has an ARP operation field of 0x0001 (bytes 21 and 22)
- The least significant 16 bits of the frame's ARP target protocol address (bytes 41 and 42) match the value programmed in bits[15:0] of the Wake-on-LAN register

The decoding of the ARP fields adjusts automatically if a VLAN tag is detected within the frame. The reserved value of 0x0000 for the Wake-on-LAN target address value does not cause an ARP request event, even if matched by the frame.

A specific address 1 filter match event occurs if all of the following are true:

- Specific address 1 events are enabled through bit [18] of the Wake-on-LAN register
- The frame's destination address matches the value programmed in the Specific Address 1 registers

A multicast filter match event occurs if all of the following are true:

- Multicast hash events are enabled through bit [19] of the Wake-on-LAN register
- Multicast hash filtering is enabled through bit [6] of the Network Configuration register
- The frame destination address matches against the multicast hash filter
- The frame destination address is not a broadcast

16.2.5 DMA Block

The DMA controller is attached to the FIFO to provide a scatter-gather type capability for packet data storage in an embedded processing system.

Packet Buffer DMA

The controller uses a packet buffer which has the following features

- 32 data bus width support
- Easier to guarantee maximum line rate due to the ability to store multiple frames in the packet buffer
- More efficient use of the AHB interface
- Full store and forward
- Support for Transmit TCP/IP checksum offload
- Support for priority queuing
- When a collision on the line occurs during transmission, the packet is automatically replayed directly from the packet buffer memory rather than having to re-fetch through the AHB interface
- Received error packets are automatically dropped before any of the packet is presented to the AHB, thus reducing AHB activity
- Supports manual RX packet flush capabilities
- RX packet flush when there is lack of AHB resource

DMA Controller

The DMA uses separate transmit and receive lists of buffer descriptors, with each descriptor describing a buffer area in memory. This allows Ethernet packets to be broken up and scattered around the AHB memory space.

The DMA controller performs four types of operation on the AHB bus. In order of priority these are:

- Receive buffer manager write/read
- Transmit buffer manager write/read
- Receive data DMA write
- Transmit data DMA read

Transfer size is set to 32-bit words using the AHB bus width select bits in the Network Configuration register, and burst size may be programmed to single access or bursts of 4, 8, or 16 words using the DMA Configuration register.

Rx Buffers

Received frames, optionally including FCS, are written to receive AHB buffers stored in memory. The start location for each receive AHB buffer is stored in memory in a list of receive buffer descriptors at an address location pointed to by the receive-buffer queue pointer. The base address for the receive-buffer queue pointer is configured in software using the Receive Buffer Queue Base Address register.

Each list entry consists of two words. The first is the address of the receive AHB buffer and the second the receive status. If the length of a receive frame exceeds the AHB buffer length, the status word for the used buffer is written with zeroes except for the *start of frame* bit, which is always set for the first buffer in a frame. Bit zero of the address field is written to 1 to show that the buffer has been used. The receive-buffer manager then reads the location of the next receive AHB buffer and fills that with the next part of the received frame data. AHB buffers are filled until the frame is complete and the final buffer descriptor status word contains the complete frame status. Refer to [Table 16-2](#) for details of the receive buffer descriptor list.

Each receive AHB buffer start location is a word address. The start of the first AHB buffer in a frame can be offset by up to three bytes depending on the value written to bits [14] and [15] of the Network Configuration register. If the start location of the AHB buffer is offset the available length of the first AHB buffer is reduced by the corresponding number of bytes.

Table 16-2: Rx Buffer Descriptor Entry

| Bit | Function |
|---------------|--|
| <i>Word 0</i> | |
| 31:2 | Address of beginning of buffer. |
| 1 | Wrap - marks last descriptor in receive buffer descriptor list. |
| 0 | Ownership - needs to be zero for the controller to write data to the receive buffer. The controller sets this to 1 once it has successfully written a frame to memory. Software must clear this bit before the buffer can be used again. |

Table 16-2: Rx Buffer Descriptor Entry (Cont'd)

| Bit | Function |
|---------------|---|
| Word 1 | |
| 31 | Global all ones broadcast address detected. |
| 30 | Multicast hash match. |
| 29 | Unicast hash match. |
| 28 | Reserved. |
| 27 | Specific address register match found,. bit 25 and bit 26 indicate which specific address register causes the match. |
| 26:25 | Specific address register match. Encoded as follows: 00b: Specific address register 1 match 01b: Specific address register 2 match 10b: Specific address register 3 match 11b: Specific address register 4 match If more than one specific address is matched only one is indicated with priority 4 down to 1. |
| 24 | This bit has a different meaning depending on whether RX checksum offloading is enabled. <ul style="list-style-type: none"> • With RX checksum offloading disabled: (bit [24] clear in Network Configuration) Type ID register match found, bit [22] and bit [23] indicate which type ID register causes the match. • With RX checksum offloading enabled: (bit [24] set in Network Configuration) <ul style="list-style-type: none"> 0b: The frame was not SNAP encoded and/or had a VLAN tag with the CFI bit set. 1b: The frame was SNAP encoded and had either no VLAN tag or a VLAN tag with the CFI bit not set. |
| 23:22 | This bit has a different meaning depending on whether RX checksum offloading is enabled. With RX checksum offloading disabled: (bit [24] clear in Network Configuration) Type ID register match. Encoded as follows: 00b: Type ID register 1 match 01b: Type ID register 2 match 10b: Type ID register 3 match 11b: Type ID register 4 match If more than one Type ID is matched only one is indicated with priority 4 down to 1. With RX checksum offloading enabled: (bit [24] set in Network Configuration) 00b: Neither the IP header checksum nor the TCP/UDP checksum was checked. 01b: The IP header checksum was checked and was correct. Neither the TCP or UDP checksum was checked. 10b: Both the IP header and TCP checksum were checked and were correct. 11b: Both the IP header and UDP checksum were checked and were correct. |
| 21 | VLAN tag detected – type ID of 0x8100. For packets incorporating the stacked VLAN processing feature, this bit is set if the second VLAN tag has a type ID of 0x8100. |
| 20 | Priority tag detected – type ID of 0x8100 and null VLAN identifier. For packets incorporating the stacked VLAN processing feature, this bit is set if the second VLAN tag has a type ID of 0x8100 and a null VLAN identifier. |
| 19:17 | VLAN priority – only valid if bit [21] is set. |
| 16 | Canonical format indicator (CFI) bit – only valid if bit 21 is set. |
| 15 | End of frame – when set the buffer contains the end of a frame. If end of frame is not set, then the only valid status bit is start of frame (bit 14). |

Table 16-2: Rx Buffer Descriptor Entry (Cont'd)

| Bit | Function |
|------|--|
| 14 | Start of frame – when set the buffer contains the start of a frame. If both bits 15 and 14 are set, the buffer contains a whole frame. |
| 13 | This bit has a different meaning depending on whether ignore FCS mode are enabled. This bit is zero if ignore FCS mode is disabled. With ignore FCS mode enabled: (bit [26] set in Network Configuration Register). This indicates per frame FCS status as follows: 0b: Frame had good FCS. 1b: Frame had bad FCS, but was copied to memory as ignore FCS enabled. |
| 12:0 | These bits represent the length of the received frame which might or might not include FCS depending on whether FCS discard mode is enabled. <ul style="list-style-type: none"> • With FCS discard mode disabled: (bit [17] clear in Network Configuration Register) Least significant 12-bits for length of frame including FCS. • With FCS discard mode enabled: (bit [17] set in Network Configuration Register) Least significant 12-bits for length of frame excluding FCS. |

The start location of the receive-buffer descriptor list must be written with the receive-buffer queue base address before reception is enabled (receive enable in the Network Control register). Once reception is enabled, any writes to the Receive-buffer Queue Base Address register are ignored. When read, it returns the current pointer position in the descriptor list, though this is only valid and stable when receive is disabled.

If the filter block indicates that a frame should be copied to memory, the receive data DMA operation starts writing data into the receive buffer. If an error occurs, the buffer is recovered.

An internal counter represents the receive-buffer queue pointer and it is not visible through the CPU interface. The receive-buffer queue pointer increments by two words after each buffer has been used. It re-initializes to the receive-buffer queue base address if any descriptor has its wrap bit set.

As receive AHB buffers are used, the receive AHB buffer manager sets bit zero of the first word of the descriptor to logic one indicating the AHB buffer has been used.

Software should search through the “used” bits in the AHB buffer descriptors to find out how many frames have been received, checking the start of frame and end of frame bits.

Received frames are written out to the AHB buffers as soon as enough frame data exists in the packet buffer. This might mean that several full AHB buffers are used before some error conditions can be detected. If a receive error is detected the receive buffer currently being written is recovered. Previous buffers are not recovered. For example, when receiving frames with CRC errors or excessive length, it is possible that a frame fragment might be stored in a sequence of AHB receive buffers. Software can detect this by looking for the start of frame bit set in a buffer following a buffer with no end of frame bit set.

For a properly working 10/100/1000 Ethernet system there should be no excessive length frames or frames greater than 128 bytes with CRC errors. Collision fragments are less than 128 bytes long, therefore it is a rare occurrence to find a frame fragment in a receive AHB buffer, when using the default value of 128 bytes for the receive buffers size.

Only good received frames are written out of the DMA, so no fragments exist in the AHB buffers due to MAC receiver errors. There is still the possibility of fragments due to DMA errors, for example used bit read on the second buffer of a multi-buffer frame.

If bit zero of the receive buffer descriptor is already set when the receive buffer manager reads the location of the receive AHB buffer, then the buffer has been already used and cannot be used again until software has processed the frame and cleared bit zero. In this case, the “buffer not available” bit in the Receive Status register is set and an interrupt is triggered. The receive resource error statistics register is also incremented.

The user can optionally select whether received frames should be automatically discarded when no AHB buffer resource is available. This feature is selected via bit [24] of the DMA Configuration register (by default, the received frames are not automatically discarded). If this feature is off, then received packets remain stored in the packet buffer until an AHB buffer resource next becomes available. This can lead to an eventual packet buffer overflow if packets continue to be received when bit zero (used bit) of the receive-buffer descriptor remains set. Note that after a used bit has been read, the receive-buffer manager re-reads the location of the receive buffer descriptor every time a new packet is received.

A receive overrun condition occurs when the receive packet buffer is full, or because hresp was not okay. In all other modes, a receive overrun condition occurs when either the AHB bus was not granted quickly enough, or because hresp was not okay, or because a new frame has been detected by the receive block, but the status update or write back for the previous frame has not yet finished. For a receive overrun condition, the receive overrun interrupt is asserted and the buffer currently being written is recovered. The next frame that is received whose address is recognized reuses the buffer.

A write to bit [18] of the Network Control register forces a packet from the receive packet buffer to be flushed. This feature is only acted upon when the RX DMA is not currently writing packet data out to AHB – i.e., it is in an IDLE state. If the RX DMA is active, a write to this bit is ignored.

Tx Buffers

Frames to transmit are stored in one or more transmit AHB buffers. It should be noted that zero length AHB buffers are allowed and that the maximum number of buffers permitted for each transmit frame is 128.

The start location for each transmit AHB buffer is stored in memory in a list of transmit buffer descriptors at a location pointed to by the transmit-buffer queue pointer. The base address for this queue pointer is set in software using the Transmit-buffer Queue Base Address register. Each list entry consists of two words. The first is the byte address of the transmit buffer and the second containing the transmit control and status. For the packet buffer DMA, the start location for each AHB buffer is a byte address, the bottom bits of the address being used to offset the start of the data from the data-word boundary. For the FIFO based DMA, the address of the buffer is also a byte address. Frames can be transmitted with or without automatic CRC generation. If CRC is automatically generated, pad will also be automatically generated to take frames to a minimum length of 64 bytes. When CRC is not automatically generated (as defined in word 1 of the transmit buffer descriptor or through the control bus of the FIFO), the frame is assumed to be at least 64 bytes long and pad is not generated.

To transmit frames, the buffer descriptors must be initialized by writing an appropriate byte address to bits [31:0] in the first word of each descriptor list entry.

The second word of the transmit-buffer descriptor is initialized with control information that indicates the length of the frame, whether or not the MAC is to append CRC, and whether the buffer is the last buffer in the frame.

After transmission the status bits are written back to the second word of the first buffer along with the used bit. Bit [31] is the used bit which must be zero when the control word is read if transmission is to take place. It is written to one when the frame has been transmitted. Bits[29:20] indicate various transmit error conditions. Bit [30] is the wrap-bit which can be set for any buffer within a frame. If no wrap bit is encountered the queue pointer continues to increment.

The Transmit-buffer Queue Base Address register can only be updated while transmission is disabled or halted; otherwise any attempted write is ignored. When transmission is halted the transmit-buffer queue pointer maintains its value. Therefore, when transmission is restarted the next descriptor read from the queue is from immediately after the last successfully transmitted frame. While transmit is disabled (bit [3] of the network control is set Low), the transmit-buffer queue pointer resets to point to the address indicated by the Transmit-buffer Queue Base Address register. Note that disabling receive does not have the same effect on the receive-buffer queue pointer.

When the transmit queue is initialized, transmit is activated by writing to the transmit start bit (bit [9]) of the Network Control register. Transmit is halted when a buffer descriptor with its used bit set is read, a transmit error occurs, or by writing to the transmit halt bit of the Network Control register. Transmission is suspended if a pause frame is received while the pause enable bit is set in the network configuration register. Rewriting the start bit while transmission is active is allowed. This is implemented with a tx_go variable which is readable in the Transmit Status register at bit location 3.

The tx_go variable is reset when:

- Transmit is disabled
- A buffer descriptor with its ownership bit set is read
- Bit [10], tx_halt, of the Network Control register is written
- There is a transmit error such as too many retries, late collision (gigabit mode only) or a transmit under-run

To set tx_go, write to bit [9], tx_start, of the Network Control register. Transmit halt does not take effect until any ongoing transmit finishes.

The entire contents of the frame are read into the transmit packet buffer memory, so the retry attempt is replayed directly from the packet buffer memory rather than having to re-fetch through the AHB.

If a used bit is read mid way through transmission of a multi buffer frame this is treated as a transmit error. Transmission stops, tx_er is asserted and the FCS is bad.

If transmission stops due to a transmit error or a used bit being read, transmission is restarted from the first buffer descriptor of the frame being transmitted when the transmit start bit is rewritten.

Refer to [Table 16-3](#) for details of the transmit buffer descriptor list.

Table 16-3: Tx Buffer Descriptor Entry

| Bit | Function |
|---------------|--|
| Word 0 | |
| 31:0 | Byte address of buffer. |
| Word 1 | |
| 31 | Used – must be zero for the controller to read data to the transmit buffer. The controller sets this to one for the first buffer of a frame once it has been successfully transmitted. Software must clear this bit before the buffer can be used again. |
| 30 | Wrap – marks last descriptor in transmit buffer descriptor list. This can be set for any buffer within the frame. |
| 29 | Retry limit exceeded, transmit error detected. |
| 28 | Always set to 0. |
| 27 | Transmit frame corruption due to AHB error – set if an error occurs whilst midway through reading transmit frame from the AHB, including HRESP errors and buffers exhausted mid frame (if the buffers run out during transmission of a frame then transmission stops, FCS shall be bad and tx_er asserted). |
| 26 | Late collision, transmit error detected. Late collisions only force this status bit to be set in gigabit mode. |
| 25:23 | Reserved. |
| 22:20 | Transmit IP/TCP/UDP checksum generation offload errors: <ul style="list-style-type: none"> • 000b: No Error. • 001b: The Packet was identified as a VLAN type, but the header was not fully complete, or had an error in it. • 010b: The Packet was identified as a SNAP type, but the header was not fully complete, or had an error in it. • 011b: The Packet was not of an IP type, or the IP packet was invalidly short, or the IP was not of type IPv4/IPv6. • 100b: The Packet was not identified as VLAN, SNAP or IP. • 101b: Non supported packet fragmentation occurred. For IPv4 packets, the IP checksum was generated and inserted. • 110b: Packet type detected was not TCP or UDP. TCP/UDP checksum was therefore not generated. For IPv4 packets, the IP checksum was generated and inserted. • 111b: A premature end of packet was detected and the TCP/UDP checksum could not be generated. |
| 19:17 | Reserved. |
| 16 | No CRC to be appended by MAC. When set this implies that the data in the buffers already contains a valid CRC and hence no CRC or padding is to be appended to the current frame by the MAC. This control bit must be set for the first buffer in a frame and is ignored for the subsequent buffers of a frame. Note that this bit must be clear when using the transmit IP/TCP/UDP checksum generation offload, otherwise checksum generation and substitution does not occur. |
| 15 | Last buffer, when set this bit indicates that the last buffer in the current frame has been reached. |
| 14 | Reserved. |
| 13:0 | Length of buffer. |

DMA Bursting on the AHB

The DMA always uses SINGLE, or INCR type AHB accesses for buffer management operations. When performing data transfers, the AHB burst length used can be programmed using bits [4:0] of the DMA Configuration register so that either SINGLE, INCR or fixed length incrementing bursts (INCR4, INCR8 or INCR16) are used where possible.

When there is enough space and enough data to be transferred, the programmed fixed length bursts are used. If there is not enough data or space available, for example when at the beginning or the end of a buffer, SINGLE type accesses are used. SINGLE type accesses are also used at 1,024 byte boundaries, so that the 1 KB boundaries are not burst over per AHB requirements.

The DMA does terminate a fixed length burst early, unless an error condition occurs on the AHB or if receive or transmit are disabled in the Network Control register.

DMA Packet Buffer

The DMA uses packet buffers for both transmit and receive paths. This mode allows multiple packets to be buffered in both transmit and receive directions. This allows the DMA to withstand far greater access latencies on the AHB and make more efficient use of the AHB bandwidth.

Full packets are buffered which provides the opportunity to:

- Discard packets with error on the receive path before they are partially written out of the DMA thus saving AHB bus bandwidth and driver processing overhead
- Retry collided transmit frames from the buffer, thus saving AHB bus bandwidth,
- Implement transmit IP/TCP/UDP checksum generation offload.

With the packet buffers included, the structure of the controller data paths is as shown in [Table 16-3](#).

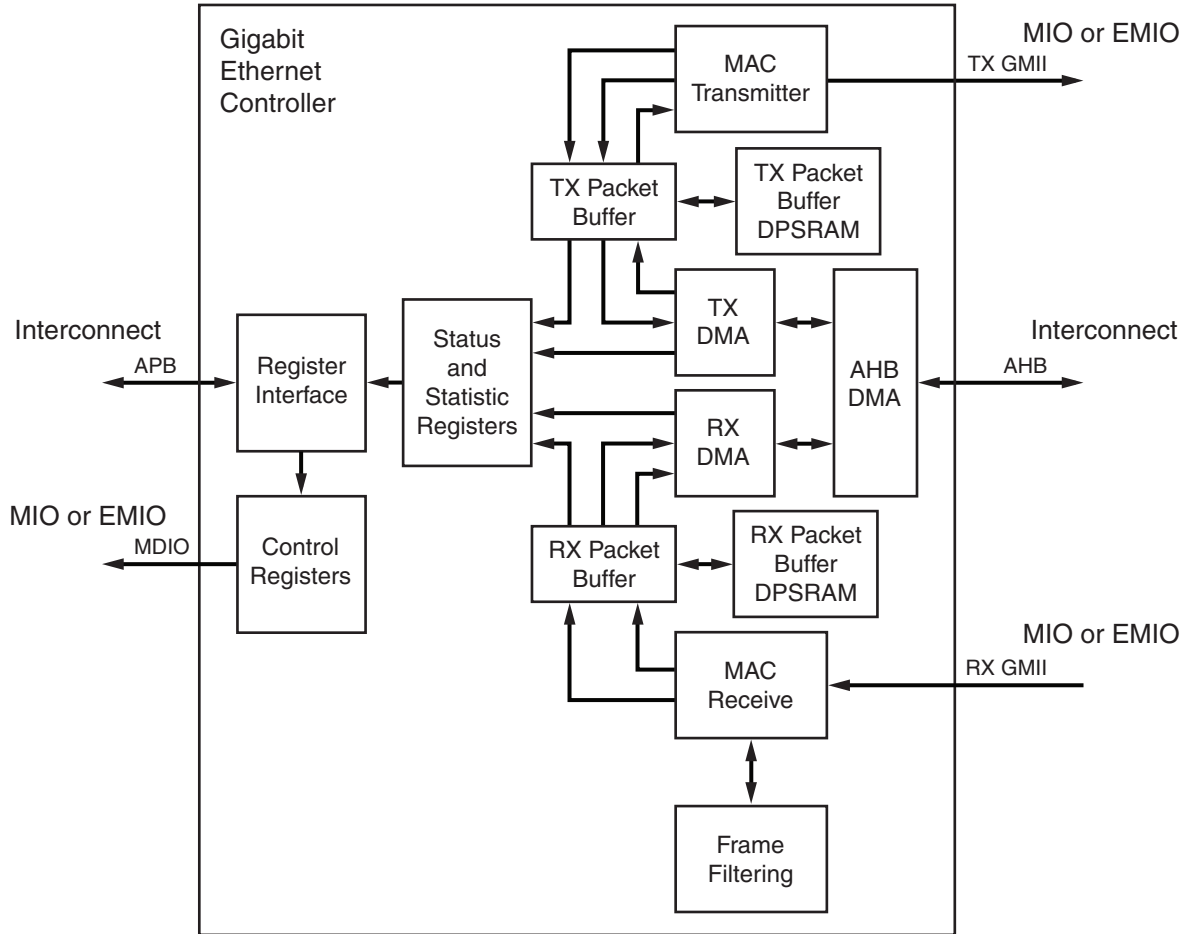

UG585_c16_03_101812

Figure 16-3: DMA Packet Buffer

In the transmit direction, the DMA continues to fetch packet data up to a limit of 256 packets, or until the buffer is full. The size of the buffer has a maximum usable size of 4 KB.

In the receive direction, if the buffer becomes full, then an overflow occurs. An overflow also occurs if the limit of 256 packets is breached. The size of the external buffer has a maximum usable size of 4 KB.

Tx Packet Buffer

The transmitter packet buffer continues to attempt to fetch frame data from the AHB system memory until the packet buffer itself is full, at which point it attempts to maintain its full level.

To accommodate the status and statistics associated with each frame, three words per packet are reserved at the end of the packet data. If the packet was bad and requires to be dropped, the status and statistics are the only information held on that packet. Storing the status in the DPRAM is required to decouple the DMA interface of the buffer from the MAC interface, to update the MAC status/stats, and to generate interrupts in the order in which the packets that they represent were fetched from the AHB memory.

If any errors occur on the AHB while reading the transmit frame, the fetching of packet data from AHB memory is halted. The MAC transmitter continues to fetch packet data, thereby emptying the packet buffer and allowing any good non-errored frames to be transmitted successfully. When these have been fully transmitted, the status/stats for the errored frame is updated and software is informed via an interrupt that an AHB error occurred. This way, the error is reported in the correct packet order.

The transmit packet buffer only attempts to read more frame data from the AHB when space is available in the packet buffer memory. If space is not available it must wait until the packet fetched by the MAC completes transmission and is subsequently removed from the packet buffer memory. Note that if full store and forward mode is active, and if a single frame is fetched that is too large for the packet buffer memory, the frame is flushed and the DMA is halted with an error status. This is because a complete frame must be written into the packet buffer before transmission can begin, and therefore the minimum packet buffer memory size should be chosen to satisfy the maximum frame to be transmitted in the application.

When the complete transmit frame is written into the packet buffer memory, a trigger is sent across to the MAC transmitter, which then begins reading the frame from the packet buffer memory. Because the whole frame is present and stable in the packet buffer memory, an underflow of the transmitter is not possible. The frame is kept in the packet buffer until notification is received from the MAC that the frame data has either been successfully transmitted or can no longer be re-transmitted (too many retries in half duplex mode). When this notification is received the frame is flushed from memory to make room for a new frame to be fetched from AHB system memory.

In half duplex mode, the frame is kept in the packet buffer until notification is received from the MAC that the frame data has either been successfully transmitted or can no longer be re-transmitted (too many retries in half duplex mode). When this notification is received the frame is flushed from memory to make room for a new frame to be fetched from AHB system memory.

In full duplex mode, the frame is removed from the packet buffer on-the-fly.

Other than underflow, the only MAC related errors that can occur are due to collisions during half duplex transmissions. When a collision occurs the frame still exists in the packet buffer memory so it can be retried directly from there. Only when the MAC transmitter has failed to transmit after sixteen attempts is the frame finally flushed from the packet buffer.

Rx Packet Buffer

The receive packet buffer stores frames from the MAC receiver along with their status and statistics. Frames with errors are flushed from the packet buffer memory, good frames are pushed onto the DMA AHB interface.

The receiver packet buffer monitors the FIFO writes from the MAC receiver and translates the FIFO pushes into packet buffer writes. At the end of the received frame the status and statistics are buffered so that the information can be used when the frame is read out. When programmed in full store and forward mode, if the frame has an error the frame data is immediately flushed from the packet buffer memory allowing subsequent frames to utilize the freed up space. The status and statistics for bad frames are still used to update the controller's registers.

Note: To accommodate the status and statistics associated with each frame, three words per packet are reserved at the end of the packet data. If the packet was bad and requires to be dropped, the status and statistics are the only information held on that packet.

The receiver packet buffer also detects a full condition such that an overflow condition can be detected. If this occurs, subsequent packets are dropped and an RX overflow interrupt is raised.

The DMA only begins packet fetches when the status and statistics for a frame are available. If the frame has a bad status due to a frame error, the status and statistics are passed onto the controller's registers. If the frame has a good status, the information is used to read the frame from the packet buffer memory and burst onto the AHB using the DMA buffer management protocol. After the last frame data has been transferred to the FIFO, the status and statistics are updated to the controller's registers.

16.2.6 Checksum Offloading

The controller can be programmed to perform IP, TCP, and UDP checksum offloading in both receive and transmit directions, enabled by setting bit [24] in the Network Configuration register for receive, and bit [11] in the DMA Configuration register for transmit.

IPv4 packets contain a 16-bit checksum field, which is the 16-bit 1's complement of the 1's complement sum of all 16-bit words in the header. TCP and UDP packets contain a 16-bit checksum field, which is the 16-bit 1's complement of the 1's complement sum of all 16-bit words in the header, the data, and a conceptual IP pseudo header.

To calculate these checksums in software requires each byte of the packet to be processed. For TCP and UDP this can use a large amount of processing power. Offloading the checksum calculation to hardware can result in significant performance improvements.

For IP, TCP, or UDP checksum offload to be useful, the operating system containing the protocol stack must be aware that this offload is available so that it can make use of the fact that the hardware can either generate or verify the checksum.

Note: While enabling UDP checksum offloading in hardware, if the checksum fields pointed to by the DMA descriptor are not initialized to 0, the calculated checksum does not provide the proper value. Therefore the checksum fields need to be initialized to 0 for checksum offloading to work properly.

Rx Checksum Offload

When receive checksum offloading is enabled, the IPv4 header checksum is checked per RFC 791, where the packet meets the following criteria:

- If present, the VLAN header must be four octets long and the CFI bit must not be set
- Encapsulation must be RFC 894 Ethernet Type encoding or RFC 1042 SNAP encoding
- IPv4 packet
- IP header is of a valid length

The controller also checks the TCP checksum per RFC 793, or the UDP checksum per RFC 768, if the following criteria are met:

- IPv4 or IPv6 packet
- Good IP header checksum (if IPv4)
- No IP fragmentation
- TCP or UDP packet

When an IP, TCP, or UDP frame is received, the receive buffer descriptor provides an indication if the controller was able to verify the checksums. There is also an indication if the frame had LLC SNAP encapsulation. These indication bits replace the type ID match indication bits when receive checksum offload is enabled.

If any of the checksums are verified to be incorrect by the controller, the packet is discarded and the appropriate statistics counter is incremented.

Tx Checksum Offload

The transmitter checksum offload is only available when the full store and forward mode is enabled. This is because the complete frame to be transmitted must be read into the packet buffer memory before the checksum can be calculated and written back into the headers at the beginning of the frame.

Transmitter checksum offload is enabled by setting bit [11] in the DMA Configuration register. When enabled, it monitors the frame as it is written into the transmitter packet buffer memory to automatically detect the protocol of the frame. Protocol support is identical to the receiver checksum offload.

For transmit checksum generation and substitution to occur, the protocol of the frame must be recognized and the frame must be provided without the FCS field, by ensuring that bit [16] of the transmit descriptor word 1 is clear. If the frame data already had the FCS field, this would be corrupted by the substitution of the new checksum fields.

If these conditions are met, the transmit checksum offload engine calculates the IP, TCP, and UDP checksums as appropriate. When the full packet is completely written into packet buffer memory, the

checksums are valid and the relevant DPRAM locations are updated for the new checksum fields as per standard IP/TCP and UDP packet structures.

If the transmitter checksum engine is prevented from generating the relevant checksums, bits [22:20] of the transmitter DMA writeback status are updated to identify the reason for the error. Note that the frame is still transmitted but without the checksum substitution, as typically the reason that the substitution did not occur was that the protocol was not recognized.

16.2.7 MAC 802.3 Pause Frame Support

Note: See Clause 31, and Annex 31A and 31B of the *IEEE standard 802.3* for a full description of pause operation.

The start of an 802.3 pause frame is shown in [Table 16-4](#)

Table 16-4: Pause Frame Information

| Destination Address | Source Address | Type (MAC Control Frame) | Pause Opcode | Pause Time |
|---------------------|----------------|-----------------------------|--------------|------------|
| 0x0180C2000001 | 6 bytes | 0x8808 | 0x0001 | 2 bytes |

The controller supports both hardware controlled pause of the transmitter upon reception of a pause frame and hardware generated pause frame transmission.

802.3 Pause Frame Reception

Bit [13] of the Network Configuration register is the pause enable control for reception. If this bit is set transmission pauses if a non zero pause quantum frame is received.

If a valid pause frame is received then the pause time register is updated with the new frame's pause time regardless of whether a previous pause frame is active or not. An interrupt (either bit [12] or bit [13] of the Interrupt Status register) is triggered when a pause frame is received, but only if the interrupt has been enabled (bit [12] and bit [13] of the Interrupt Mask register). Pause frames received with non zero quantum are indicated through the interrupt bit [12] of the Interrupt Status register. Pause frames received with zero quantum are indicated on bit [13] of the Interrupt Status register.

When the pause time register is loaded and the frame currently being transmitted has been sent, no new frames are transmitted until the pause time reaches zero. The loading of a new pause time, and hence the pausing of transmission, only occurs when the controller is configured for full duplex operation. If the controller is configured for half duplex there is no transmission pause, but the pause frame received interrupt is still triggered. A valid pause frame is defined as having a destination address that matches either the address stored in Specific Address register 1 or if it matches the reserved address of 0x0180C2000001. It must also have the MAC control frame type ID of 0x8808 and have the pause opcode of 0x0001.

Pause frames that have FCS or other errors are treated as invalid and are discarded. 802.3 Pause frames that are received after priority based flow control (PFC) has been negotiated are also discarded. Valid pause frames received increment the Pause Frames Received Statistic register.

The Pause Time register decrements every 512 bit times once transmission has stopped. For test purposes, the retry test bit can be set (bit [12] in the Network Configuration register) which causes the Pause Time register to decrement every tx_clk cycle when transmission has stopped.

The interrupt (bit [13] in the Interrupt Status register) is asserted whenever the pause time register decrements to zero (assuming it has been enabled by bit [13] in the Interrupt Mask register). This interrupt is also set when a zero quantum pause frame is received.

802.3 Pause Frame Transmission

Automatic transmission of pause frames is supported through the transmit pause frame bits of the Network Control register and from the external input pins tx_pause, tx_pause_zero and tx_pfc_sel. If either bit [11] or bit [12] of the Network Control register is written with logic 1, or if the input signal tx_pause is toggled when tx_pfc_sel is Low, an 802.3 pause frame is transmitted providing full duplex is selected in the Network Configuration register and the transmit block is enabled in the Network Control register.

Pause frame transmission occurs immediately if transmit is inactive or if transmit is active between the current frame and the next frame due to be transmitted.

Transmitted pause frames comprise of the following:

- A destination address of 01-80-C2-00-00-01
- A source address taken from Specific Address register 1
- A type ID of 88-08 (MAC control frame)
- A pause opcode of 00-01
- A pause quantum register
- Fill of 00 to take the frame to minimum frame length
- Valid FCS

The pause quantum used in the generated frame depends on the trigger source for the frame as follows:

- If bit [11] is written with a one, the pause quantum is taken from the Transmit Pause Quantum register. The Transmit Pause Quantum register resets to a value of 0xFFFF giving maximum pause quantum as the default.
- If bit [12] is written with a one, the pause quantum is zero.
- If the tx_pause input is toggled, tx_pfc_sel is Low and the tx_pause_zero input is held Low until the next toggle, the pause quantum is taken from the Transmit Pause Quantum register.
- If the tx_pause input is toggled, tx_pfc_sel is Low and the tx_pause_zero input is held High until the next toggle, the pause quantum is zero.

After transmission, a pause frame transmitted interrupt is generated (bit [14] of the Interrupt Status register) and the only statistics register that is incremented is the Pause Frames Transmitted register.

Pause frames can also be transmitted by the MAC using normal frame transmission methods.

MAC PFC Priority Based Pause Frame Support

Note: Refer to the 802.1Qbb standard for a full description of priority based pause operation.

The controller supports PFC priority based pause transmission and reception. Before PFC pause frames can be received, bit 16 of the Network Control register must be set. The start of a PFC pause frame is shown in [Table 16-5](#).

Table 16-5: PFC Priority Based Pause Frame Info

| Destination Address | Source Address | Type (MAC Control Frame) | Pause Opcode | Priority Enable Vector | Pause Times |
|---------------------|----------------|--------------------------|--------------|------------------------|-------------|
| 0x0180C2000001 | 6 bytes | 0x8808 | 0x0101 | 2 bytes | 8 * 2 bytes |

PFC Pause Frame Reception

The ability to receive and decode priority based pause frames is enabled by setting bit [16] of the Network Control register. When this bit is set, the controller matches either classic 802.3 pause frames or PFC priority based pause frames. Once a priority based pause frame has been received and matched, then from that moment on the controller only matches on priority based pause frames (this is an 802.1Qbb requirement, known as PFC negotiation). Once priority based pause has been negotiated, any received 802.3x format pause frames are not acted upon. The state of PFC negotiation is identified via the output `pfc_negotiate`.

If a valid priority based pause frame is received then the controller decodes the frame and determines which, if any, of the eight priorities require to be paused. Up to eight Pause Time registers are then updated with the eight pause times extracted from the frame, regardless of whether a previous pause operation is active or not. An interrupt (either bit [12] or bit [13] of the Interrupt Status register) is triggered when a pause frame is received, but only if the interrupt has been enabled (via bit[12] and bit[13] of the Interrupt Mask register).

Pause frames received with non zero quantum are indicated through the interrupt bit[12] of the Interrupt Status register. Pause frames received with zero quanta are indicated on bit[13] of the Interrupt Status register. The state of the eight pause time counters are indicated through the outputs `rx_pfc_paused`. These outputs remain High for the duration of the pause time quanta. The loading of a new pause time only occurs when the controller is configured for full duplex operation. If the controller is configured for half duplex, the pause time counters are not loaded, but the pause frame received interrupt is still triggered.

A valid pause frame is defined as having a destination address that matches either the address stored in Specific Address register 1 or if it matches the reserved address of 0x0180C2000001. It must also have the MAC control frame type ID of 0x8808 and have the pause opcode of 0x0101.

Pause frames that have FCS or other errors are treated as invalid and are discarded. Valid pause frames received increment the pause Frames Received Statistic register.

The Pause Time registers decrement every 512 bit times immediately following the PFC frame reception. For test purposes, the retry test bit can be set (bit [12] in the Network Configuration register) which causes the Pause Time register to decrement every `rx_clk` cycle once transmission has stopped.

The interrupt (bit [13] in the Interrupt Status register) is asserted whenever the Pause Time register decrements to zero (assuming it has been enabled by bit [13] in the Interrupt Mask register). This interrupt is also set when a zero quantum pause frame is received.

PFC Pause Frame Transmission

Automatic transmission of pause frames is supported through the transmit priority based pause frame bit of the Network Control register and from the external input pins tx_pause, tx_pfc_pause[7:0], tx_pfc_pause_zero[7:0], and tx_pfc_sel. If bit 17 of the Network Control register is written with logic 1, or if the input signal tx_pause is toggled when tx_pfc_sel is High, a PFC pause frame is transmitted providing full duplex is selected in the Network Configuration register and the transmit block is enabled in the Network Control register. When bit 17 of the Network Control register is set, the fields of the priority based pause frame are built using the values stored in the Transmit PFC Pause register.

Pause frame transmission occurs immediately if transmit is inactive or if transmit is active between the current frame and the next frame due to be transmitted.

Transmitted pause frames comprise of the following:

- A destination address of 01-80-C2-00-00-01
- A source address taken from Specific Address register 1
- A type ID of 88-08 (MAC control frame)
- A pause opcode of 01-01
- A priority enable vector taken from tx_pfc_pause or the Transmit PFC Pause register
- Eight pause quantum registers
- Fill of 00 to take the frame to minimum frame length
- Valid FCS

The Pause Quantum registers used in the generated frame depend on the trigger source for the frame as follows:

- If bit [17] of the Network Control register is written with a one then the priority enable vector of the priority based pause frame is set equal to the value stored in the Transmit PFC Pause register [7:0]. For each entry equal to zero in the Transmit PFC Pause register[15:8], the pause quantum field of the pause frame associated with that entry is taken from the Transmit Pause Quantum register. For each entry equal to one in the Transmit PFC Pause register[15:8], the pause quantum associated with that entry is zero.
- The Transmit Pause Quantum register resets to a value of 0xFFFF giving maximum pause quantum as default.
- If the tx_pause input is toggled and tx_pfc_sel is High then the priority enable vector of the priority based pause frame is set equal to the value in tx_pfc_pause [7:0]. For each entry equal to zero in tx_pfc_pause_zero[7:0], the pause quantum field of the pause frame associated with that entry is taken from the Transmit Pause Quantum register. For each entry equal to one in tx_pfc_pause_zero [7:0], the pause quantum associated with that entry is zero.

After transmission, a pause frame transmitted interrupt is generated (bit 14 of the Interrupt Status register) and the only statistics register that is incremented is the Pause Frames Transmitted register. PFC Pause frames can also be transmitted by the MAC using normal frame transmission methods.

Limitation

The GEM controller registers require single 32-bit read/write accesses, do not use byte, halfword, or double word references.

16.3 Programming Guide

The controller functionality is described in detail in section [16.2 Functional Description and Programming Model](#). All of the controller registers are listed in [Table 16-8](#) and [Table 16-9](#) and are described in detail in [Appendix B, Register Details](#).

Example: Programming Steps

1. [16.3.1 Initialize the Controller](#)
2. [16.3.2 Configure the Controller](#)
3. [16.3.3 I/O Configuration](#)
4. [16.3.4 Configure the PHY](#)
5. [16.3.5 Configure the Buffer Descriptors](#)
6. [16.3.6 Configure Interrupts](#)
7. [16.3.7 Enable the Controller](#)
8. [16.3.8 Transmitting Frames](#)
9. [16.3.9 Receiving Frames](#)
10. [16.3.10 Debug Guide](#)

For information on building the ethernet system for Zynq, refer to the followings:

- [XAPP1026](#), *LightWeight IP Application Examples*
- [XAPP1082](#), *PS and PL Ethernet Performance and Jumbo Frame Support with PL Ethernet in the Zynq-7000 SoC*
- [Baremetal Drivers and Libraries](#)
- [OS and Libraries Document Collection](#)
- [Zynq PL Ethernet](#)

16.3.1 Initialize the Controller

1. **Clear the Network Control register.** Write 0x0 to gem.net_ctrl register.
2. **Clear the Statistics registers.** Write a 1 to gem.net_ctrl[clear_stat_regs].
3. **Clear the Status registers.** Write a 1 to the Status registers. gem.rx_status = 0x0F and gem.tx_status = 0xFF.
4. **Disable all interrupts.** Write 0x7FF_FEFF to the gem.intr_dis register.
5. **Clear the buffer queues.** Write 0x0 to the gem.rx_qbar and gem.tx_qbar registers.

16.3.2 Configure the Controller

The following example describes a typical programming sequence for configuration of the controller. Refer to [Appendix B, Register Details](#) for further details on the Controller registers.

1. **Program the Network Configuration register (gem.net_cfg).** The network configuration register is used to set the mode of operation.

Examples:

- a. **Enable Full Duplex.** Write a 1 to the gem.net_cfg[full_duplex] register.
 - b. **Enable Gigabit mode.** Write a 1 to the gem.net_cfg[gige_en] register.
 - c. **Enable default speed for 100 Mbps.** Write a 1 to the gem.net_cfg[speed] register.
Note: The speed bit might have to be re-written after PHY auto-negotiation.
 - d. **Enable reception of broadcast or multicast frames.** Write a 0 to the gem.net_cfg[no_broadcast] register to enable broadcast frames and write a 1 to the gem.net_cfg[multi_hash_en] register to enable multicast frames.
 - e. **Enable promiscuous mode.** Write a 1 to the gem.net_cfg[copy_all] register.
 - f. **Enable TCP/IP checksum offload feature on receive.** Write a 1 to the gem.net_cfg[rx_chksum_offld_en] register. (Refer to section [16.2.6 Checksum Offloading](#).)
 - g. **Enable Pause frames.** Write a 1 to gem.net_cfg[pause_en] register.
 - h. **Set the MDC clock divisor.** Write the appropriate MDC clock divisor to the gem.net_cfg[mdc_clk_div] register. (Refer to section [16.3.4 Configure the PHY](#).)
2. **Set the MAC address.** Write to the gem.spec1_addr1_bot and gem.spec1_addr1_top registers. The least significant 32 bits of the MAC address go to gem.spec1_addr1_bot and the most significant 16 bits go to gem.spec1_addr1_top.
 3. **Program the DMA Configuration register (gem.dma_cfg).**
 - a. **Set the receive buffer size to 1,600 bytes.** Write a value of 0x19 to the gem.dma_cfg[ahb_mem_rx_buf_size] register.
 - b. **Set the receiver packet buffer memory size to the full configured addressable space of 8 KB.** Write 0x3 to the gem.dma_cfg[rx_pktbuf_memsz_sel] register.
 - c. **Set the transmitter packet buffer memory size to the full configured addressable space of 4 KB.** Write 0x1 to the gem.dma_cfg[tx_pktbuf_memsz_sel] register.
 - d. **Enable TCP/IP checksum generation offload on the transmitter.** Write 0x1 to the gem.dma_cfg[csum_gen_offload_en] register.
 - e. **Configure for Little Endian system.** Write 0x0 to the gem.dma_cfg[ahb_endian_swp_pkt_en] register.
 - f. **Configure AHB fixed burst length.** Write 0x10 to the gem.dma_cfg[ahb_fixed_burst_len] register to use INCR16 AHB burst for higher performance.
 4. **Program the Network Control Register (gem.net_ctrl).**
 - a. **Enable MDIO.** Write a 1 to the gem.net_ctrl[mgmt_port_en] register.
 - b. **Enable the Transmitter.** Write a 1 to the gem.net_ctrl[tx_en] register.
 - c. **Enable the Receiver.** Write a 1 to the gem.net_ctrl[rx_en] register.

16.3.3 I/O Configuration

The block diagram in section [16.1.1 Block Diagram](#) describes the connection details of the Gigabit Ethernet Controller to the external network.

Gigabit Ethernet Controller using MIO

The controller provides an RGMII interface through the MIO. Pins 16-27 are used for Controller 0 and 28-39 for Controller 1. Refer to section [16.6 Signals and I/O Connections](#) for more information on the pin-out.

Example: Configuring Controllers for MIO

The controllers can be configured to operate in HSTL or CMOS IO standards. Refer to [Chapter 2, Signals, Interfaces, and Pins](#) for more information on MIO pin configuration. The following steps illustrate the configuration for Controller 0.

- 1. Write to the `slcr.MIO_PIN{16:21}` registers for the transmit signals.** This programs the MIO I/O buffers (GPIOB) for the four transmit data signals, transmit clock and transmit control signals.
Example: A value of `0x0000_3902` disables the HSTL receiver, specifies HSTL I/O type, enables internal pull-up, disables 3-state control and routes the transmit data, clock, and control signals.
- 2. Write to the `slcr.MIO_PIN{22:27}` registers for the receive signals.**
Example: A value of `0x0000_1903` enables HSTL receiver, specifies HSTL I/O type, enables internal pull-up, disables 3-state control and routes the receive data, clock, and control signals.
- 3. Write to `slcr.MIO_PIN{52:53}` registers for the management signals.**
Example: A value of `0x0000_1280` enables the HSTL receiver, specifies HSTL I/O type, enables internal pull-up, and routes the MDIO clock/data.
- 4. Write a value of `0x0000_0001` to the `slcr.GPIOB` register to enable the VREF internal generator.**

Similarly, replace `SLCR.MIO_PIN{16:27}` with `SLCR.MIO_PIN{28:39}` for Controller 1.

Note: The clock might have to be reprogrammed after auto-negotiation.

Gigabit Ethernet Controller using EMIO

The EMIO interface allows for derivation of other physical MII interfaces using appropriate shim-logic in the PL. The Controller provides a GMII interface through the EMIO.

Example: Configure Controllers for EMIO

1. **Unlock the SLCR module.** Write a value of `0xDF0D` to the `slcr.SLCR_UNLOCK` register.
2. Enable the level shifters for PS user inputs to FPGA. Write a value of `4'b1010` to bit field `slcr.LVL_SHFTR_EN[USER_LVL_SHFTR_EN]`.
3. **Write a value of 0 to the `slcr.FPGA_RST_CTRL` register.**
4. **Perform a software reset.** Write `0b1` to bits `slcr.FPGA_RST_CTRL[FPGA{0-3}_OUT_RST]`.
5. **Write a value of 0 to the `slcr.FPGA_RST_CTRL` register.**
6. **Lock the SLCR module.** Write a value of `0x767B` to the `slcr.SLCR_LOCK` register.

Configure Clocks

The Gigabit Ethernet Controller clocks are controlled through four registers in the SLCR module.

Example: Configuring Clocks for MIO

1. **Unlock the SLCR module.** Write a value of `0xDF0D` to `slcr.SLCR_UNLOCK` register.
2. **Configure the clock by writing to the `slcr.GEM0_CLK_CTRL` register.**

Example: A value of `0x0050_0801` enables the Controller0 reference clock, first divisor for the source clock is 8 and second divisor is 5. This gives a default speed of 100 Mb/s if the Ethernet source clock is IO PLL which has a frequency of 1,000 MHz.

3. **Enable Controller 0 receive clock control.** Write a value of `0x0000_0001` to the `slcr.GEM0_RCLK_CTRL` register.
4. **Lock the SLCR module.** Write a value of `0x767B` to `slcr.SLCR_LOCK` register.

Similar steps must be followed for Controller 1 by writing to the appropriate registers.

16.3.4 Configure the PHY

The PHY connected to the controller is initialized through the available management interface (MDIO) using the PHY maintenance register (`gem.phy_maint`). Writing to this register starts a shift operation which is signaled as complete when the bit `gem.net_status[phy_mgmt_idle]` is set.

The MDIO interface clock (MDC) for GigE is generated by dividing down the CPU_1x clock.

Note: MDC is active only during MDIO read or write operations during which the PHY registers are read or written.

The MDC must not exceed 2.5 MHz as defined by the IEEE802.3 standard. The `gem.net_cfg[mdc_clk_div]` bits are used to set the divisor for the CPU_1x clock.

Example: Consider a case with the CPU clock set to 666.667 MHz clock and the available CPU_1x clock is 111.11 MHz. The clock divisor, in this case should be set to 48 (0b011) in `gem.net_cfg[mdc_clk_div]` to set the maximum possible frequency of 2.314 MHz for the MDC.

PHY configuration and initialization is unique for every system. Refer to the vendor data sheet for more information and PHY register details.

Example: PHY Read/Write Operation

1. **Check to see that no MDIO operation is in progress.** Read until `gem.net_status[phy_mgmt_idle] = 1`.
2. **Write data to the PHY maintenance register(`gem.phy_maint`).** This initiates the shift operation over MDIO. Refer to [Appendix B, Register Details](#) section [B.18 Gigabit Ethernet Controller \(GEM\)](#) for register information.
3. **Wait for completion of operation.** Read until `gem.net_status[phy_mgmt_idle] = 1`.
4. **Read data bits for a read operation.** The PHY register data is available in `gem.phy_maint[data]`.

Example: PHY Initialization

1. **Detect the PHY address.** Read the PHY identifier fields in PHY registers 2 and 3 for all the PHY addresses ranging from 1 to 32. The register contents will be valid for a valid PHY address.
2. **Advertise the relevant speed/duplex settings.** These bits can be set to suit the system. Refer to the PHY vendor data sheet for more information.
3. **Configure the PHY as applicable.** This could include options to set PHY mode, timing options in the PHY or others as applicable to the system. Refer to the PHY vendor datasheet for more information.
4. **Wait for completion of Auto-negotiation.** Read the PHY status register. Refer to the PHY vendor data sheet for more information.
5. **Update Controller with auto-negotiated speed and duplex settings.** Read the relevant PHY registers to determine the negotiated speed and duplex. Set the speed in `gem.net_cfg[gige_en]` and `gem.net_cfg[speed]` bits and the duplex in `gem.net_cfg[full_duplex]`.

Note: The SLCR register must be updated for clock updates (refer to [Configure Clocks, page 514](#)).

16.3.5 Configure the Buffer Descriptors

Receive Buffer Descriptor List

The data received by the controller is written to pre-allocated buffer descriptors in system memory. These buffer descriptor entries are listed in the receive buffer queue. Refer to section [16.2.5 DMA Block](#) and [Table 16-2, page 496](#) for more information on implementation and structure of the Rx Buffer Descriptor.

The Receive-buffer Queue Pointer register (`gem.rx_qbar`) points to this data structure as shown in [Figure 16-4](#).

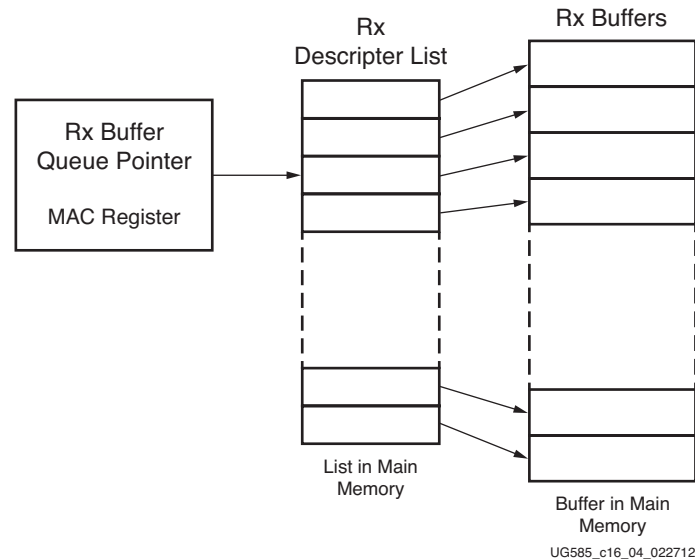

Figure 16-4: Rx Buffer Queue Structure

To create this list of buffers:

1. Allocate a number (N) of buffers of X bytes in system memory, where X is the DMA buffer length programmed in the DMA Configuration register.

Example: This controller assumes that the maximum size of an Ethernet packet without jumbo frame support can reach up to 1,536 bytes. So allocate N number of buffers each with a size of 1,536 bytes in system memory. The buffers typically need to be aligned to cache-line boundaries to improve performance. Typical values of N can be 64 or 128.

2. Each buffer descriptor is of 8 bytes length. Hence allocate an area of 8N bytes for the receive buffer descriptor list in system memory. This creates N entries in this list.

Note: A single cache line for the Zynq-7000 SoC is 32 bytes and can contain 4 buffer descriptors. This means flushing or invalidating a single buffer descriptor entry in the cache memory results in flushing or invalidation of a cache line which in turn affects the adjacent buffer descriptors. This can result in undesirable behavior. It is typical to allocate the buffer descriptor list in an un-cached memory region.

3. Mark all entries in this list as owned by controller. Set bit 0 of word 0 of each buffer descriptor to 0.
4. Mark the last descriptor in the buffer descriptor list with the wrap bit (bit 1 in word 0) set.
5. Write the base address of receive buffer descriptor list to controller register gem.rx_qbar.
6. Fill the addresses of the allocated buffers in the buffer descriptors (bits 31-2, Word 0).
7. Write the base address of this buffer descriptor list to the gem.rx_qbar register.

Transmit Buffer Descriptor List

The data to be transmitted is read from buffers present in system memory. These buffers are listed in the transmit buffer queue. Refer to section 16.2.5 DMA Block and Table 16-2, page 496 for more information on implementation and structure of the Tx buffer descriptor.

The Transmit Buffer Queue Pointer register (gem.tx_qbar) register points to this data structure.

To create this list of buffer descriptors with N entries:

1. Each buffer descriptor is 8 bytes in length. Hence allocate an area of 8N bytes for the transmit buffer descriptor list in system memory which creates N entries in this list. It is advisable to use un-cached memory for allocating the complete buffer descriptor list for the reasons already described for the [Receive Buffer Descriptor List](#).
2. Mark all entries in this list as owned by the controller. Set bit[31] of word 1 to 0.
3. Mark the last descriptor in the list with the wrap bit. Set bit[30] in word 1 to 1.
4. Write the base address of transmit buffer descriptor list to Controller register gem.tx_qbar.

16.3.6 Configure Interrupts

There are 26 interrupt conditions that are detected within the controller which are OR-ed to generate a single interrupt. Additionally there is a Wake-on-LAN interrupt driven from the Ethernet controller. These two interrupts are then passed to the GIC pl390 interrupt controller.

Refer to the description of register, gem.intr_status in [Appendix B, Register Details](#) for more information on the list of interrupt conditions identified by the controller.

An appropriate handler for the interrupt should be registered with the CPU for processing an interrupt condition. The CPU suspends its normal activity, moves to interrupt processing mode and executes the corresponding handler for an interrupt condition.

Example: Configuring Interrupts

1. **Register a handler.** There are two interrupts generated by the controller - Wake-on-LAN and another interrupt for all other functions. Register the handler for each of these interrupt types with the CPU.
Note: In a typical case, a single handler is used for both transmission and reception of packets. Once the control reaches the handler, the software should read the gem.intr_status register to determine the source and perform the relevant function.
2. **Enable the necessary interrupt conditions.** The relevant bits in the gem.intr_en register must be set. The interrupt conditions necessary are determined by the system architecture.
Note: Read the read-only register gem.intr_mask for current the mask state of each interrupt.

16.3.7 Enable the Controller

The receiver and transmitter must be enabled after configuration:

1. **Enable the Transmitter.** Write a 1 to `gem.net_ctrl[tx_en]`.
2. **Enable the Receiver.** Write a 1 to `gem.net_ctrl[rx_en]`.

16.3.8 Transmitting Frames

Example: Transmitting a Frame

1. **Allocate buffers in system memory to contain the Ethernet frame.** GigE supports scatter-gather functionality; hence an Ethernet frame can be split into multiple buffers with each buffer processed by a buffer descriptor.
2. **Write the Ethernet frame data in the allocated buffers.** These Ethernet frames should have their header fields such as destination MAC address, source MAC address and type/length field set appropriately.

Notes:

- The FCS field is added by the MAC in most cases. However if there is a need to append a custom FCS, bit 16 in word 1 of the corresponding buffer descriptor must be set.
- The buffer that contains the Ethernet frame data should be flushed from cache if cached memory is being used.

3. **Allocate buffer descriptor(s) for the Ethernet frame buffers.** This involves setting bits 0-31 in the buffer descriptor word 0 with the address of the buffer and setting bits 0-13 in word 1 with the length of the buffer to be transmitted.

Notes:

- For single buffer Ethernet frames, bit 15 (Last buffer bit) of the word 1 must also be set.
- For Ethernet frames scattered across multiple buffers the buffer descriptors must be allocated serially and the buffer descriptor containing the last buffer should have the bit 15 of word 1 set.

Example: For an Ethernet frame of 1,000 bytes split across two buffers with the first buffer containing the Ethernet header (14 bytes) and the next buffer containing the remaining 986 bytes, the buffer descriptor with index N should be allocated for the first buffer and the buffer descriptor with index N+1 should be allocated for the second buffer. Bit 15 of word 1 of the N+1 buffer descriptor must also be set to mark it as the last buffer in the scattered list of Ethernet frames.

4. **Clear the used bit (bit 31) in word 1 for all allocated buffer descriptors.** However, wait to clear the bit in the first descriptor until after all the others have been cleared.
5. **Enable transmission.** Write a 1 to `gem.net_ctrl[start_tx]`.
6. **Wait until the transmission is complete.** An interrupt is generated by the controller upon successful completion of the transmission. Read and clear the `gem.intr_status[tx_complete]` bit by writing a 1 to the bit in the interrupt handler. Also read and clear the `gem.tx_status` register by writing a 1 to `gem.tx_status[tx_complete]` bit. Clear all bits in the BD except the used and wrap bits.

16.3.9 Receiving Frames

When a frame is received with the receive circuits enabled, the controller checks the address and the frame is written to system memory in the following cases:

- The destination address matches one of the four specific address registers. This is applicable for cases where the MAC address for the controller is set in the `gem.spec_addr{1:4}_bot` and `gem.spec_addr{1:4}_top` registers.
- The received frame's type/length field matches one of the four type ID registers. The available type ID registers are `gem.type_id_match{1:4}`. This is applicable for cases where Ethernet type/length field based filtering is required.
- Unicast or Multicast hash is enabled through `gem.net_cfg[uni_hash_en]` or `gem.net_cfg[multi_hash_en]` register bits, then the received frame is accepted only if the hash is matched.
- The destination address is a broadcast address (`0xFFFFFFFFFFFF`) and broadcasts are allowed. This option is set using the `gem.net_cfg[no_broadcast]` register bit.
- The controller is configured for promiscuous mode with the `gem.net_cfg[copy_all]` register bit set.

The register `gem.rx_qbar` points to the next entry in the receive buffer descriptor list and the controller uses this as the address in system memory to write the frame. When the frame has been completely received and written to system memory, the controller then updates the receive buffer descriptor entry with the reason for the address match, marks the area as being owned by software, and sets the receive complete interrupt (`gem.intr_status[rx_complete] = 1`). Software is then responsible for copying the data to the application area and releasing the buffer.

If the controller is unable to write the data at a rate to match the incoming frame, then the receiver overrun interrupt is set (`gem.intr_status[rx_overrun] = 1`). If there is no receive buffer available, i.e., the next buffer is still owned by software, a receive-buffer not available interrupt is set. If the frame is not successfully received, a Statistic register is incremented and the frame is discarded without informing software.

Example: Handling a Received Frame

1. **Wait for the controller to receive a frame.** The receive complete interrupt, `gem.intr_status[rx_complete]`, is generated when a frame is received.
2. **Service the interrupt.** Read and clear the `gem.intr_status[rx_complete]` register bit writing a 1 to the bit in the interrupt handler. Also read and clear the `gem.rx_status` register by writing a 1 to `gem.rx_status[frame_recvd]` bit.
3. **Process the data in the buffer.** Scan the buffer descriptor list for the buffer descriptors with the ownership bit (bit 0, Word 0) set. When the DMA receive buffer size programmed to 1,600 bytes (`gem.dma_cfg[ahb_mem_rx_buf_size] = 0x19`), the packets on the receive side are not scattered and always go into a single buffer. For a buffer descriptor with the ownership bit set, process the buffer allocated in the corresponding buffer descriptor and set the ownership bit to 0. Read other bit fields in the relevant buffer descriptor word 1, take necessary action, and clear them.

16.3.10 Debug Guide

The GigE can encounter different kinds of errors while receiving or transmitting Ethernet frames. Refer to [Appendix B, Register Details](#) for more information on the transmit and receive error conditions listed in the description for gem.tx_status and gem.rx_status registers, respectively. Some common errors and the action necessary is described in [Table 16-6](#) and [Table 16-7](#).

Table 16-6: RX Status Errors

| Error Condition | Necessary Action |
|----------------------|---|
| Hresp not OK | This is a condition from which the controller cannot recover easily. Re-initialize the controller and buffer descriptors for receive and transmit paths after clearing the relevant register status bits: gem.rx_status[hresp_not_ok] and gem.intr_status[hresp_not_ok]. |
| Receive overrun | This condition implies that the packet is dropped because the packet buffer is full and occurs occasionally when the controller is unable to process the packets when they arrive very fast. In most conditions, no action for error recovery needs to be taken. Ensure that the packet buffer is configured for 8 KB (see section 16.3.2 Configure the Controller) and clear bits gem.rx_status[rx_overrun] and gem.intr_status[rx_overrun]. |
| Buffer not available | This condition implies that the controller could not get a buffer descriptor with the ownership bit set to 0. It can also mean that the software is unable to keep pace with the incoming packet rate. Clear bits gem.rx_status[buffer_not_avail] and gem.intr_status[rx_used_read] in the interrupt handler. Attempt increasing the number of buffer descriptors on the receive path to allocate more number of buffers. The software processing can be optimized further to accelerate processing of received frames. |

Table 16-7: TX Status Errors

| Error Condition | Necessary Action |
|---------------------------|--|
| Hresp not OK | This is a condition from which the controller cannot recover easily. Re-initialize the controller and buffer descriptors for receive and transmit paths after clearing the relevant register status bits: gem.tx_status[hresp_not_ok] and gem.intr_status[hresp_not_ok]. |
| Transmit underrun | This implies a severe error condition on the transmit side in processing of the transmit buffers and buffer descriptors. For effective error recovery, the software must disable the transmitter by writing a 0 to the gem.net_ctrl[tx_en] bit, then re-initialize the buffer descriptors on the transmit side and enable the transmitter by writing a 1 to the gem.net_ctrl[tx_en] bit. The bit gem.tx_status[tx_under_run] must be cleared in the interrupt handler. |
| Transmit buffer exhausted | This is a severe error condition on the transmit side. For effective error recovery, the software must disable the transmitter by writing a 0 to the gem.net_ctrl[tx_en] bit, then re-initialize the transmit buffer descriptors and transmitter. The register bits gem.tx_status[tx_corr_ahb_err] and gem.intr_status[tx_corrupt_ahb_err] must be cleared in the interrupt handler. |

Table 16-7: TX Status Errors (Cont'd)

| Error Condition | Necessary Action |
|----------------------|---|
| Retry limit exceeded | This implies there are a series of collisions for which an Ethernet frame could not be sent out even with a number of retries in half-duplex communication. This Ethernet frames are dropped at the transmitter. The bits <code>gem.tx_status[retry_limit_exceeded]</code> and <code>gem.intr_status[retry_ex_late_collisn]</code> must be cleared in the interrupt handler. No drastic measures need to be taken for this error. However it could also mean that there is a duplex setting mismatch. |
| Collisions | This error indicates that there are collisions for half duplex communication. Some collisions are expected in half duplex mode and can be ignored. When a collision occurs, the frame is retransmitted after a while and the frame is not dropped. The register bit <code>gem.tx_status[collision]</code> must be cleared in the interrupt handler. |

16.4 IEEE 1588 Timestamping

Zynq GEM 1588 feature is discontinued because of the following limitations:

- The timestamp generated on a PTP event is stored in a non-latching register. This means that the timestamp is overwritten whenever a PTP event packet arrives. Hence, there is no accurate way to associate a timestamp with the packet.
- An application using sync, follow up, pdelay request, pdelay response with a sync cycle of 1 second and no errors in between might work but it is not reliable because sync will fail the moment there is any deviation. For example, multiple back to back PTP event packets in the same direction or a small sync interval on a high traffic system where the SW is unable to process the timestamp register before it is overwritten.

16.5 Register Overview

16.5.1 Control Registers

Control registers drive the management data input/output (MDIO) interface, set-up DMA activity, start frame transmission, and select the different modes of operation such as full duplex, half duplex and 10/100/1000 Mb/s operation. (See [Table 16-8](#).)

Table 16-8: Ethernet Control Register Overview

| Function | Register Name | Description |
|------------------------------------|--|--|
| MAC Configuration | net_{cfg,ctrl,status} tx_pauseq rx_pauseq tx_pfc_pause ipg_stretch stacked_vlan | Network control, configuration and status. Rx, Tx Pause clocks. IPG stretch. |
| DMA Unit | tx_status rx_status tx_qbar rx_qbar dma_cfg | Control. Receive, Transmit Status. Receive, Transmit Queue Base Address Control. |
| Interrupts | intr_{status,en,dis, mask} | Interrupt status, enable/disable, and mask |
| | intr_dis_pq{1:7} | |
| | intr_en_pq{1:7} | |
| | intr_mask_pq{1:7} | |
| wake_on_lan | | |
| isr_pq{1:7} | | |
| PHY Maintenance | phy_maint | PHY maintenance |
| MAC Address Filtering and ID Match | hash_{top,bot} spec_addr{1:4}_{bot,top} spec_addr1_mask_{bot,top} type_id_match{1:4} | Hash address, Specific {4:1} addresses High/Low. Match Type. |
| Clocks and Reset | slcr.GEM{1,0}_CLK_CTRL slcr.GEM{1,0}_RCLK_CTRL slcr.GEM{1,0}_CPU_1XCLKACT slcr.GEM_RST_CTRL | Refer to Chapter 25, Clocks and Chapter 26, Reset System for more information. |
| I/O Signal Routing | slcr.MIO_PIN_{xxx} | Refer to IOP Interface Connections, page 49 for MIO pin programming information. |

16.5.2 Status and Statistics Registers

The statistics registers hold counts for various types of events associated with transmit and receive operations. These registers, along with the status words stored in the receive buffer list, enable software to generate network management statistics compatible with IEEE 802.3. (See [Table 16-9](#)).

Table 16-9: Ethernet Status and Statistics Register Overview

| Function | Hardware Register Name | Description |
|------------------------------------|--|--|
| Frame Tx Statistics | frames_tx broadcast_frames_tx multi_frames_tx | Error-free Tx frame, pause frame counts and bytes counts. |
| | frames_64b_tx frames_65to127b_tx frames_128to255b_tx frames_256to511b_tx frames_512to1023b_tx frames_1024to1518b_tx | Error-free frames transmitted: totals by size. |
| | octets_tx_{top,bot} | Octets transmitted. |
| | deferred_tx_frames | |
| | pause_frames_tx tx_under_runs | Frames received High/Low, Under-run error count. |
| | Frame Tx Statistics for Half Duplex Transmission | {multi,single}_collisn_frames excessive_collisns late_collisns carrier_sense_errs |
| Frame Rx Statistics | frames_rx bdcast_fames_rx multi_frames_rx | Error-free frames received: normal, broadcast, multicast, pause. |
| | frames_64b_rx frames_65to127b_rx frames_128to255b_rx frames_256to511b_rx frames_512to1023b_rx frames_1024to1518b_rx | Error-free frames received: totals by size. |
| | {undersz,oversz,jab}_rx | Undersize, oversize and jabber frames. |
| | fcs_errors length_field_errors | Frame sequence, length, symbol, alignment error counters. |
| | octets_rx_{top,bot} | |
| | rx_symbol_errors align_errors rx_resource_errors rx_overrun_errors | Rx resource, overrun and last statistic clearing offset for clearing. |
| Frame Rx Checksum Error Statistics | ip_hdr_csum_errors tcp_csum_errors udp_csum_errors | Checksum error counters: IP Header, TCP, UDP |

16.6 Signals and I/O Connections

16.6.1 MIO–EMIO Interface Routing

The I/O interface is routed to the MIO for RGMII, and to the EMIO for GMII/MII connectivity. The PL can modify the GMII/MII interface from the MAC to construct other Ethernet interfaces that connect to external devices via PL pins. The routing of the Ethernet communications signals are shown in [Figure 16-5](#). The Ethernet communications ports are independently routed to the MIO pins (as RGMII) or to a set of EMIO interface signals (as GMII). When using the EMIO interface both the TX and RX clocks are inputs to the PS.

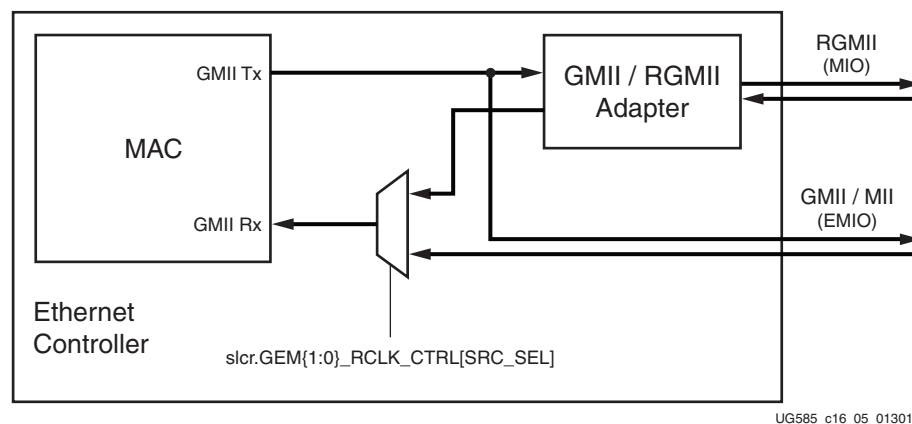

Figure 16-5: Interface Select Multiplexer

16.6.2 Programmable Logic (PL) Implementations

There are options to provide further external interface standard support by linking the GMII signals on the EMIO interface to the PL. Users can design and connect logic to generate other interface standards on the PL pins.

TBI support can be provided by connecting the GMII to a TBI compatible logic core in the PL which provides the PCS functions required for ten-bit interfacing to an external PHY via the PL pins. SGMII or 1000 Base-X support can be provided by connecting the GMII to an SGMII or 1000 Base-X compatible logic core which provides the required PCS functions and signal adaptation and drives an MGT for serial interfacing to an external PHY.

16.6.3 RGMII Interface via MIO

An example Ethernet communications wiring connection is shown in [Figure 16-6](#)

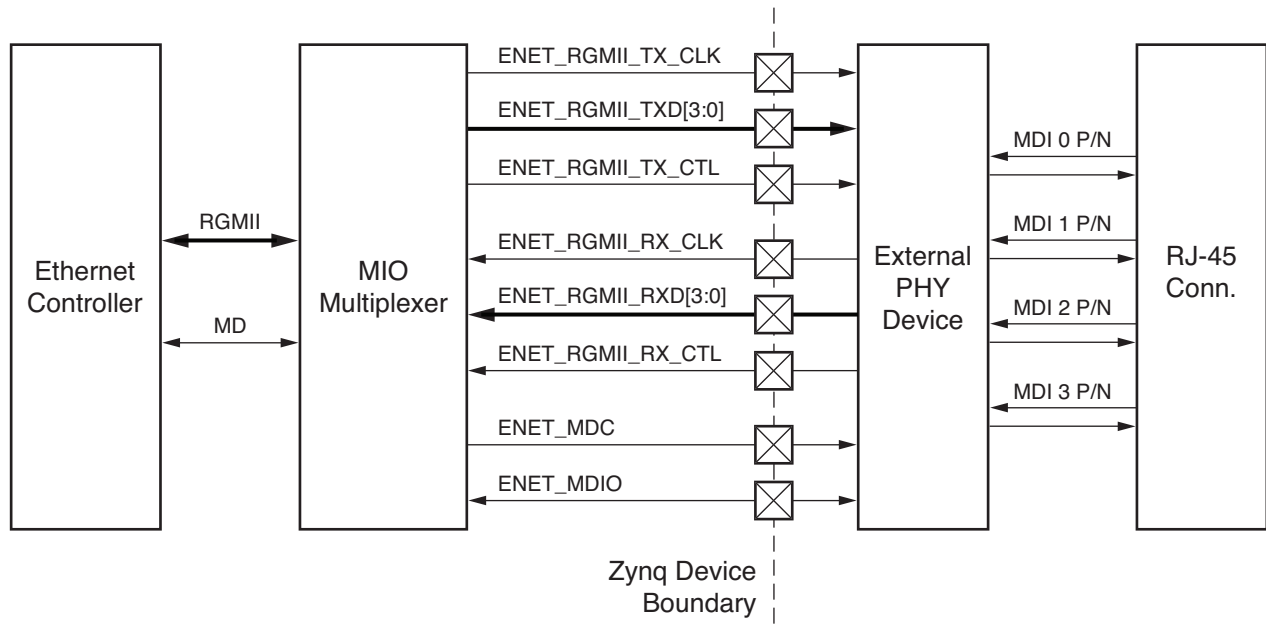

UG585_c16_06_022712

Figure 16-6: Ethernet Communications Wiring Connections

All Ethernet I/O pins routed through the MIO are on MIO Bank 1 (see Table 16-10). The MIO pins and restrictions based on device version are shown in the MIO table in section 2.5.4 MIO-at-a-Glance Table.

Table 16-10: Ethernet RGMII Interface Signals via MIO Pins

| Controller Signal | | MIO Pins | | | |
|---------------------|--------------------------------|----------|--------|--------------|-----|
| Signal Description | Default Controller Input Value | GigE 0 | GigE 1 | Name | I/O |
| Tx clock to PHY | ~ | 16 | 28 | RGMII_TX_CLK | O |
| Tx control to PHY | ~ | 21 | 33 | RGMII_TX_CTL | O |
| Tx data 0 to PHY | ~ | 17 | 29 | RGMII_TX_D0 | O |
| Tx data 1 to PHY | ~ | 18 | 30 | RGMII_TX_D1 | O |
| Tx data 2 to PHY | ~ | 19 | 31 | RGMII_TX_D2 | O |
| Tx data 3 to PHY | ~ | 20 | 32 | RGMII_TX_D3 | O |
| Rx clock from PHY | 0 | 22 | 34 | RGMII_RX_CLK | I |
| Rx control from PHY | 0 | 27 | 39 | RGMII_RX_CTL | I |
| Rx data 0 from PHY | 0 | 23 | 35 | RGMII_RX_D0 | I |
| Rx data 1 from PHY | 0 | 24 | 36 | RGMII_RX_D1 | I |
| Rx data 2 from PHY | 0 | 25 | 37 | RGMII_RX_D2 | I |
| Rx data 3 from PHY | 0 | 26 | 38 | RGMII_RX_D3 | I |

16.6.4 GMII/MII Interface via EMIO

An example illustrating the GMII interface connections through the PL to the PL pins is shown in Figure 16-7. Ethernet GMII/MII interface signals routed through the EMIO are identified in Table 16-11.

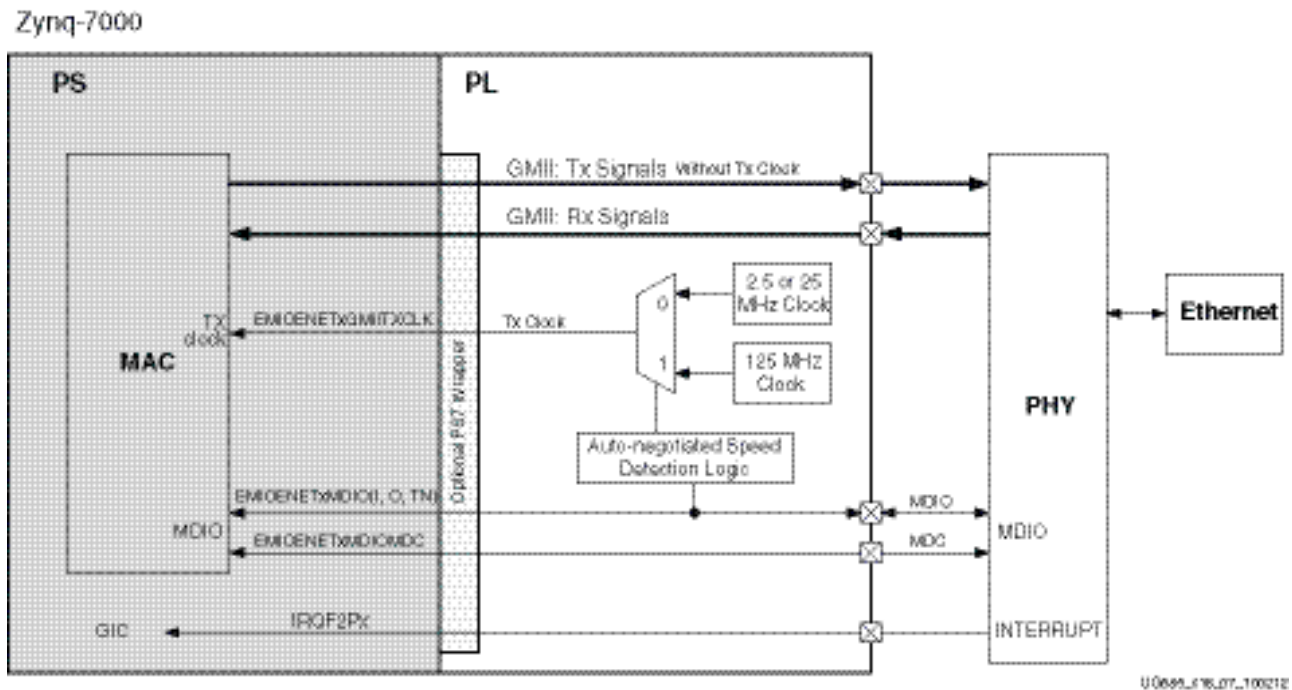

Figure 16-7: GMII Interface via EMIO Connections

Table 16-11: Ethernet GMII/MII Interface Signals via EMIO Interface

| Interface Signal | Reference Clock | Default Controller Input Value | EMIO Interface Signals | |
|------------------------------|-----------------|--------------------------------|-----------------------------|-----|
| | | | Name | I/O |
| Carrier sense | ~ | | EMIOENET[1,0]GMIICRS | I |
| Collision detect | ~ | | EMIOENET[1,0]GMIICOL | I |
| Controller interrupt wake-up | ~ | | EMIOENET[1,0]IRQF2P [5, 13] | I |
| Tx Signals | | | | |
| Tx Clock | ~ | | EMIOENET[1,0]GMIITXCLK | I |
| Tx Data (7:0) | Tx Clk | ~ | EMIOENET[1,0]GMIITXD[7:0] | O |
| Tx Enable | Tx Clk | ~ | EMIOENET[1,0]GMIITXEN | O |
| Tx Error | Tx Clk | ~ | EMIOENET[1,0]GMIITXER | O |
| Rx Signals | | | | |
| Rx Clock | ~ | | EMIOENET[1,0]GMIIRXCLK | I |
| Rx Data (7:0) | Rx Clk | | EMIOENET[1,0]GMIIRXD[7:0] | I |
| Rx Data valid | Rx Clk | | EMIOENET[1,0]GMIIRXDV | I |
| Rx Error | Rx Clk | | EMIOENET[1,0]GMIIRXER | I |

Table 16-11: Ethernet GMII/MII Interface Signals via EMIO Interface (Cont'd)

| Interface Signal | Reference Clock | Default Controller Input Value | EMIO Interface Signals | |
|------------------|-----------------|--------------------------------|------------------------|-----|
| | | | Name | I/O |

Notes:

1. If using MII connect the RX[7:4] bits to logic zero.

16.6.5 MDIO Interface Signals via MIO and EMIO

MDIO interface signals routed through the MIO and EMIO are identified in [Table 16-12](#).

Table 16-12: MDIO Interface Signals via MIO and EMIO

| MDIO Interface | Default Controller Input Value | MIO Pins | | | | EMIO Interface Signals | |
|-----------------|--------------------------------|----------|--------|-----|----------|------------------------|-----|
| | | GigE 0 | GigE 1 | I/O | Name | Name | I/O |
| MD clock output | ~ | 52 | 52 | O | MDIO_CLK | EMIOENET[1:0]MDIOMDC | O |
| MD data output | ~ | 53 | 53 | IO | MDIO_IO | EMIOENET[1:0]MDIOO | O |
| MD data 3-state | ~ | | | | | EMIOENET[1:0]MDIOTN | O |
| MD data input | 0 | | | | | EMIOENET[1:0]MDIOI | I |

16.6.6 MIO Pin Considerations

LVC MOS33 is not supported for the RGMII interface. Recommendation is to use 1.8/2.5V I/O standards.

16.7 Known Issues

1. On TX, GigE needs multiple descriptors with the last descriptor in the BD ring having the used bit set. It is needed to ensure the GigE does not wrap and attempt to transmit the same frames more than once.

On RX, there is no hard requirement to have multiple buffer descriptors, although it is a very sensible thing to minimize the chance of getting buffer resource errors (where the hardware has a frame to write to memory, but there is no free buffer(s) to write to). Extreme overflow conditions in general are more likely when these buffer resource errors occur.

Workaround: Configure at least two buffer descriptors for both Tx/Rx data paths.

2. It is possible to have the last frame(s) stuck in the RX FIFO with the software having no way to get the last frame(s) out of there. The GEM only initiates a descriptor request when it receives another frame. Therefore, when a frame is in the FIFO and a descriptor only becomes available at a later time and no new frames arrive, there is no way to get that frame out or even know that it exists.

This issue does not occur under typical operating conditions. Typical operating conditions are when the system always has incoming Ethernet frames. The above mentioned issue occurs when the MAC stops receiving the Ethernet frames.

Workaround: There is no workaround in the software except to ensure a continual flow of Ethernet frames.

3. When discarding a frame or detecting an error, the GEM stores a status packet in the receive FIFO (write side) indicating the erroneous condition. Once that status packet reaches the front of the FIFO (read side) the error counter is incremented. When the FIFO is full no additional status packets can be written into the FIFO and any further errors are discarded. For example, there could be thousands of overflow errors but the overflow error counter only registers the first few. This problem applies to all errors for which stats are maintained.

As a secondary problem the errors are only visible once they reach the front of the FIFO. If there is a packet at the beginning of the FIFO that cannot be written to memory because of unavailability of a RX DMA descriptor, many errors could occur that are not visible to software. The error counters stay at zero because all the error status packets are backed up behind the data packet.

Workaround: There is no workaround in the software.

4. GigE has an issue with the Rx packet buffer DMA design. The issue occurs under extreme Rx traffic conditions with not enough DMA bandwidth. This results in the Rx packet buffer filling up, leading to an overflow. The packet buffer overflow causes an overflow status word to be written into the packet buffer for reporting. If the extreme traffic condition persists for a long time, this results in a large number of such overflow status words being written into the packet buffer. This eventually overflows an 8-bit internal counter in the GigE Rx module used to track the number of packets in the Rx buffer needing a "read out." Once the 8-bit counter overflows, it leads to corruption of local fill level counters in the GigE, which results in a deadlock on the Rx path.

The chances of running into this issue is very high if GigE is subjected to a heavy Rx traffic condition with small-sized packets. A typical example could be small-sized UDP packets.

Workaround: Once a deadlock is hit on the Rx path, reset the Rx path by first writing a 0 to the `gem.net_ctrl[rx_en]` bit and then a writing a 1 to the same bit. The software can have a timer mechanism to perform this task. In a typical example, the software can create a timer which expires every 100 milliseconds. In the timer handler the software can monitor the register `gem.frames_rx`, which stores the number of received error-free frames. If the SW finds out that the GigE has stopped receiving error-free frames in two successive invocation of the timer handler, it resets the Rx path by writing a 0 and then a 1 to the `gem.net_ctrl[rx_en]` bit.

SPI Controller

17.1 Introduction

The SPI bus controller enables communications with a variety of peripherals such as memories, temperature sensors, pressure sensors, analog converters, real-time clocks, displays, and any SD card with serial mode support. The SPI controller can function in master mode, slave mode or multi-master mode. The Zynq-7000 devices include two SPI controllers. The controller is based on the Cadence SPI core.

In master mode, the controller drives the serial clock and slave selects with an option to support SPI's multi-master mode. The serial clock is derived from the PS clock subsystem. The controller initiates messages using up to 3 individual slave select (SS) output signals that can be externally expanded. The controller reads and writes to slave devices by writing bytes to the 32-bit read/write data port register.

In multi-master mode, the controller three-states its output signals when the controller is not active and can detect contention errors when enabled. The outputs are three-stated immediately by resetting the SPI enable bit. An Interrupt Status register indicates a mode fault.

In slave mode, the controller receives the serial clock from the external device and uses the SPI_Ref_Clk to synchronize data capture. The slave mode includes a programmable start detection mechanism when the controller is enabled while the SS is asserted.

The read and write FIFOs provide buffering between the SPI I/O interface and the software servicing the controller via the APB slave interface. The FIFO are used for both slave and master I/O modes.

This chapter is organized into the following sections:

- [17.1 Introduction](#)
- [17.2 Functional Description](#)
- [17.3 Programming Guide](#)
- [17.4 System Functions](#)
- [17.5 I/O Interfaces](#)

17.1.1 Features

Each SPI controller is configured and controlled independently, They include the following features:

- Four wire bus – MOSI, MISO, SCLK, and SS
 - up to 3 slave selects for master mode
- Full-duplex operation offers simultaneous receive and transmit
- 32-bit register programming via APB slave interface
- Memory mapped read/write data ports for Rx/Tx FIFOs (byte-wide)
 - 128-byte read and 128-byte write FIFOs
 - Programmable FIFO thresholds status and interrupts
- Master I/O mode
 - Manual and auto start transmission of data
 - Manual and auto slave select (SS) mode
 - Slave select signals can be connected directly to slave devices or expanded externally
 - Programmable SS and MOSI delays
- Slave I/O mode
 - Programmable start detection mode
- Multi-master I/O Capable
 - Drives I/O buffers into 3-state if controller is not enabled
 - Generates a Mode Failure interrupt when another master is detected
- 50 MHz SCLK clock frequency when I/O signals are routed to the MIO pins
 - 25 MHz SCLK when the I/O signals are routed via the EMIO interface to the PL pins
- Programmable clock phase and polarity (CPHA, CPOL)
- Programmable interrupt-driven device or poll status

17.1.2 System Viewpoint

The system viewpoint diagram of the SPI controller is shown in [Figure 17-1](#).

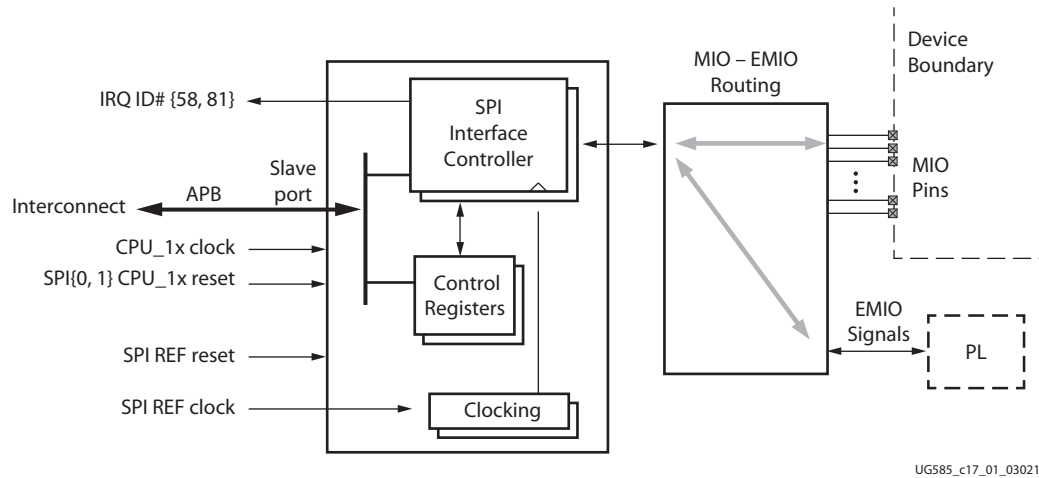

Figure 17-1: SPI System Block Diagram

SPI Interface Controller

There are two independent SPI interface controllers (SPI_x; where $x = 0$ or 1). The I/O signals of each independent controller can be routed to MIO pins or the EMIO interface. Each controller also has individual interrupts signals to the PS interrupt controller and a separate reset signal. Each controller has its own set of control and status registers.

Clocking

The PS clock subsystem provides a reference clock to the SPI controller. The SPI_Ref_Clk clock is used for the controller logic and by the baud rate generator to create the SCLK clock for master mode.

MIO-EMIO

The SPI I/O signals can be routed to the MIO pins or the EMIO interface to the PL, as explained in [17.5 I/O Interfaces](#). The general routing of signals is explained in [Chapter 2, Signals, Interfaces, and Pins](#).

17.1.3 Block Diagram

A functional block diagram of the SPI controller is shown in [Figure 17-2](#).

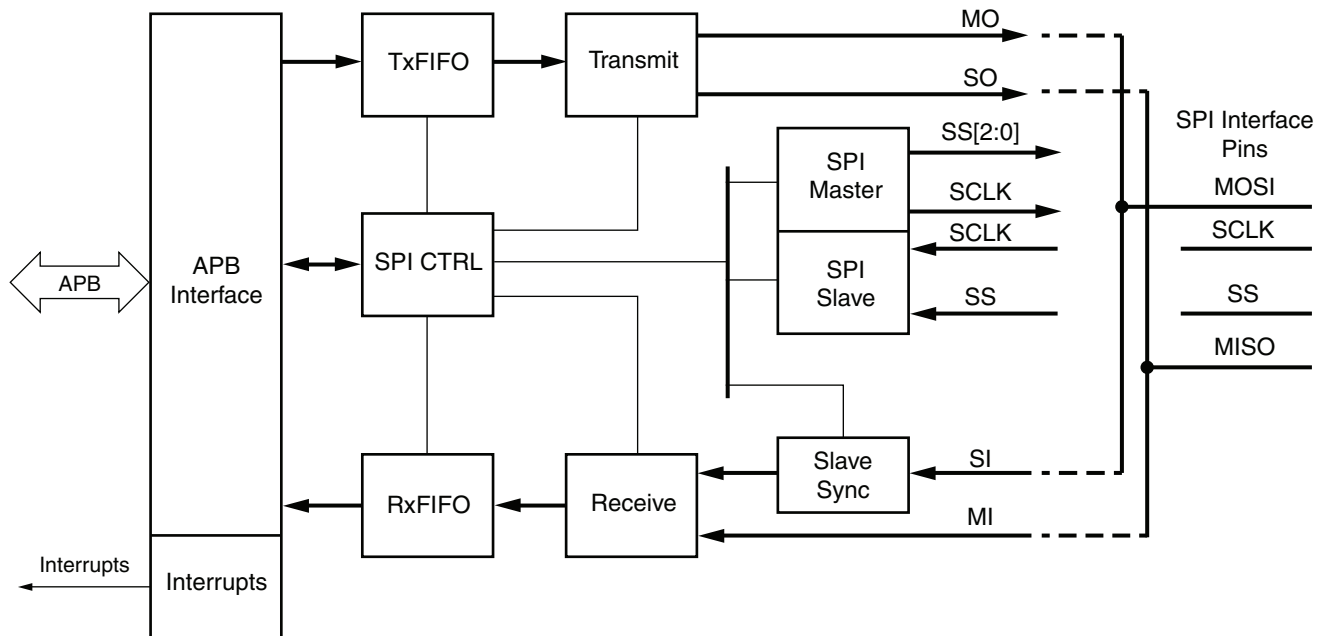

UG585_c17_02_072512

Figure 17-2: SPI Peripheral Block Diagram

APB Slave Interface

The 32-bit APB slave interface responds to register reads and writes, including data ports for reading and writing commands and data from and to the FIFOs. All registers transactions are 32 bits. The data ports use bits [7:0] of these ports. The configuration and status registers are listed in [Appendix B, Register Details](#).

SPI Master Mode

When the controller operates in master mode, it drives the SCLK clock and up to 3 slave select output signals. The SS and start of transmission on MOSI can be manually controlled by software or automatically controlled by the hardware.

SPI Slave Mode

When the controller operates in slave mode, it uses a single slave select input (SS 0). The SPI signals are shown in [Figure 17-2](#) and listed in [section 17.5 I/O Interfaces](#). The SCLK is synchronized to the controller reference clock (SPI_Ref_Clk). Refer to [section 17.2.3 Slave Mode](#).

Tx and Rx FIFOs

Each FIFO is 128 bytes. Software reads and writes these FIFOs using the register mapped data port registers. FIFO management for master mode is described in [17.3.3 Master Mode Data Transfer](#) and for slave mode in [17.3.4 Slave Mode Data Transfer](#).

The FIFOs bridge two clock domains; APB interface and the controller's SPI_Ref_Clk. Software writes to the TxFIFO in the APB clock domain and the controller reads the TxFIFO in the SPI_Ref_Clk domain.

The controller fills the RxFIFO in the SPI_Ref_Clk domain and software reads the RxFIFO in the APB clock domain.

17.1.4 Notices

7z007s and 7z010 CLG225 Devices

The 7z007s single core and 7z010 dual core CLG225 devices support 32 MIO pins (not 54). This is shown in the MIO table in section [2.5.4 MIO-at-a-Glance Table](#). These devices restrict the available MIO pins so connections through the EMIO should be considered. All of these CLG225 device restrictions are listed in section [1.1.3 Notices](#).

17.2 Functional Description

- [17.2.1 Master Mode](#)
- [17.2.2 Multi-Master Capability](#)
- [17.2.3 Slave Mode](#)
- [17.2.4 FIFOs](#)
- [17.2.5 FIFO Interrupts](#)
- [17.2.6 Interrupt Register Bits, Logic Flow](#)
- [17.2.7 SPI-to-SPI Connection](#)

17.2.1 Master Mode

In master mode, the SPI I/O interface can transmit data to a slave or initiate a transfer to receive data from a slave. The controller selects one slave device at the time using one of the three slave select lines. If more than three slave devices need to be connected to the master, it is possible to add an external peripheral select 3-to-8 decode on the board.

Data Transfer

The SCLK clock and MOSI signals are under control of the master. Data to be transmitted is written into the TxFIFO by software using register writes and then unloaded for transmission by the controller hardware in a manual or automatic start sequence. Data is driven onto the master output (MOSI) data pin. Transmission is continuous while there is data in the TxFIFO.

Data is received serially on the MISO data pin and is loaded 8 bits at a time into the RxFIFO. Software reads the RxFIFO using register reads. For every “n” bytes written to the TxFIFO, there will be “n” bytes stored in RxFIFO that must be read by software before starting the next transfer.

Auto/Manual SS and Start

Data transfers on the I/O interface can be manually started using software or automatically started by the controller hardware. In addition, the slave select assertion/de-assertion can be done by the controller hardware or from software. These four combinations are shown in [Table 17-1](#).

Table 17-1: SPI Master Mode SS and Start Modes

| Slave Select Control | Data Transfer Start Control | Manual Slave Select | Manual Start Enable & Command | Operation |
|----------------------|-----------------------------|---------------------|-------------------------------|---|
| Manual SS (software) | Manual Start | 1 | 1 | Software controls the slave select and must issue the start command to serialize data. |
| | Auto Start | 1 | 0 | Software controls the slave select, but the controller hardware automatically starts to serialize data when there is data in the TxFIFO. Recommended for general use. |

Table 17-1: SPI Master Mode SS and Start Modes (Cont'd)

| Slave Select Control | Data Transfer Start Control | Manual Slave Select | Manual Start Enable & Command | Operation |
|----------------------|-----------------------------|---------------------|-------------------------------|--|
| Auto SS (controller) | Manual Start | 0 | 1 | Controller hardware controls the slave select, but the software must issue the start command to serialize data in the TxFIFO. This mode is applicable for specific use cases such as sending small chunks of data that fit into the SPI controller FIFO. |
| | Auto Start | 0 | 0 | Controller hardware controls the slave select and serializes data when there is data in the TxFIFO. |

Manual SS

Software selects the manual slave select method by setting the spi.Config_reg0 [Manual_CS] bit = 1. In this mode, software must explicitly control the slave select assertion/de-assertion. When the [Manual_CS] bit = 0, the controller hardware automatically asserts the slave select during a data transfer.

Automatic SS

Software selects the auto slave select method by programming the spi.Config_reg0 [Manual_CS] bit = 0. The SPI controller asserts/de-asserts the slave select for each transfer of TxFIFO content on to the MOSI signal. Software writes data to the TxFIFO and the controller asserts the slave select automatically, transmits the data in the TxFIFO and then de-asserts the slave select. The slave select gets de-asserted after all the data in the Tx FIFO is transmitted. This is the end of the transfer.

Software ensures the following in automatic slave select mode.

- Software continuously fills the TxFIFO with the data bytes to be transmitted, without the TxFIFO becoming empty, to maintain an asserted slave select.
- Software continuously reads data bytes received in the Rx FIFO to avoid overflow.

Software uses the TxFIFO and Rx FIFO threshold levels to avoid FIFO under- and over-flows. The TxFIFO Not Full condition is flagged when the number of bytes in TxFIFO is less than the TxFIFO threshold level. The Rx FIFO full condition is flagged when the number of bytes in Rx FIFO is equal to 128.

Manual Start

Enable

Software selects the manual transfer method by setting the spi.Config_reg0 [Man_start_en] bit = 1. In this mode, software must explicitly start the data transfer using manual start command mechanism. When the [Man_start_en] bit = 0, the controller hardware automatically starts the data transfer when there is data available in the TxFIFO.

Command

Software starts a manual transfer by writing a 1 to the spi.Config_reg0 [Man_start_com] bit. When the software writes the 1, the controller hardware starts the data transfer and transfers all the data bytes present in the TxFIFO. The [Man_start_com] bit is self-clearing. Writing a 1 to this bit is ignored if [Man_start_en] = 0. Writing a 0 to [Man_start_com] has no effect, regardless of mode.

17.2.2 Multi-Master Capability

For Multi-master mode, the controller is programmed for master mode [MODE_SEL] and can initiate transfers on any of the slave selects. When the software is ready to initiate a transfer, it enables the controller using the [SPI_EN] bit. When the transaction is done, the software disables the controller. The controller cannot be selected by an external master when the controller is in Master Mode.

The controller detects another master on the bus by monitoring the open-drain slave select signal (active Low). The detection mechanism is enabled by the [Modedefail_gen_en]. When the controller detects another master, it sets the spi.Intr_status_reg0 [MODE_FAIL] interrupt status bit and clears the spi.En_reg0 [SPI_EN] control bit. The software can receive the [MODE_FAIL] interrupt so it can abort the transfer, reset the controller, and re-send the transfer.

17.2.3 Slave Mode

In slave mode, the controller receives messages from the external master and outputs a simultaneous reply. The controller enters slave mode when spi.Config_reg0 [MODE_SEL] = 0 and spi.En_reg0 [SPI_EN] = 1.

The SCLK latches data on the MOSI input. If the slave select input signal is High (inactive), the controller ignores the MOSI input. When the slave select is asserted, it must be held active for the duration of the transfer. If SS de-asserts during the transfer, the controller sets the spi.Intr_status_reg0 [MODE_FAIL] interrupt bit. The software receives the [MODE_FAIL] interrupt so it can abort the transfer, reset the controller, and re-send the transfer.

The error mechanism is enabled by the [Modedefail_gen_en] bit.

Data to be sent to the master is written into the TxFIFO by software and then serialized onto the master input (MISO) signal by the controller. Transmission continues while there is still data in the TxFIFO and the slave select signal remains asserted (active Low).

Clocking

The slave select input pin must be driven synchronously to the SCLK input. The controller operates in the SPI_Ref_Clk clock domain. The input signals are synchronized and analyzed in the SPI_Ref_Clk domain.

Word Detection

The start of a word is detected in the SPI_Ref_Clk clock domain.

- **Detection when Controller is enabled:** If the controller is enabled (from a disabled state) at a time when SS is Low (active), the controller will ignore the data and wait for the SCLK to be inactive (a word boundary) before capturing data. The controller counts SCLK inactivity in the SPI_Ref_Clk domain. A new word is assumed when the SCLK idle count reaches the value programmed into the [Slave_Idle_coun] bit field.
- **Detection when SS asserts:** With the controller enabled and SS is detected High (inactive), the controller will assume the start of the word occurs on the next active edge of SCLK after SS transitions Low (active).

Note: The start condition must be held active for at least four SPI_Ref_Clk cycles to be detected.

If slave mode is enabled at a time when the external master is very close to starting a data transfer, there is a small probability that false synchronization will occur, causing packet corruption. This issue can be avoided by any of the following means:

- Ensure that the external master does not initiate data transfer until at least ten SPI_Ref_Clk cycles have passed after slave mode has been enabled.
- Ensure that slave mode is enabled before the external master is enabled.
- Ensure that the slave select input signal is not active when the slave is enabled.

17.2.4 FIFOs

The Rx and Tx FIFOs are each 128 bytes deep.

RxFIFO

If the controller attempts to push data into a full RxFIFO then the content is lost and the sticky overflow flag is set. No data is added to a full RxFIFO. Software writes a 1 to the bit to clear the [RX_OVERFLOW] bit.

TxFIFO

If the TxFIFO is full, [TX_FIFO_full] = 1, then do not write more data. The TX_FIFO_Full bit remains asserted until the TxFIFO level is less than the [TxFIFO_Not_Full] threshold level. Data written to a full TxFIFO may be lost without any indication.

17.2.5 FIFO Interrupts

The Rx and Tx FIFO interrupts are illustrated in Figure 17-3.

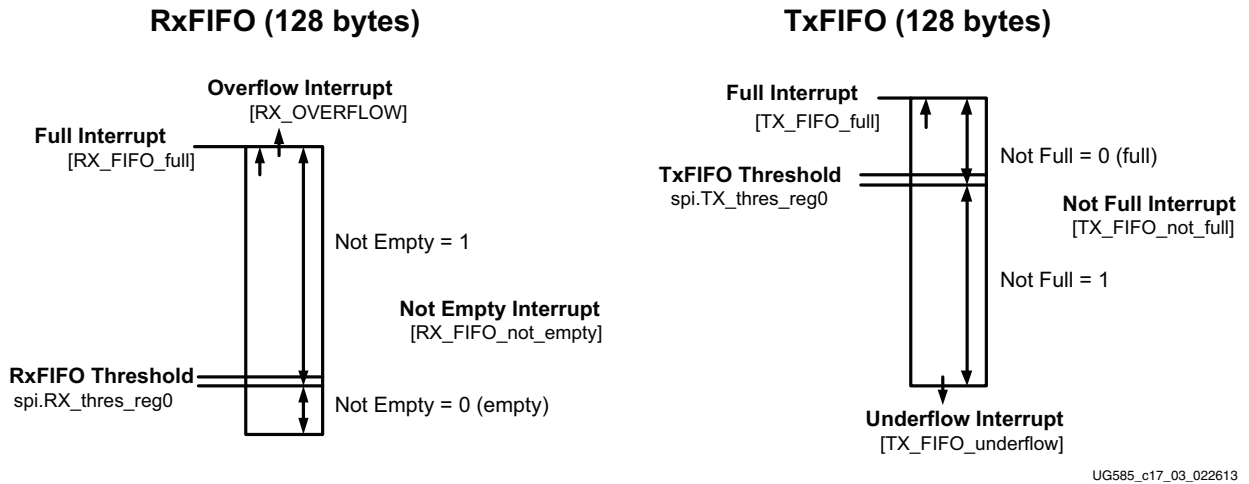

UG585_c17_03_022613

Figure 17-3: SPI Rx and Tx FIFO Interrupts

17.2.6 Interrupt Register Bits, Logic Flow

The interrupts are seen in the status register, however, the interrupt status bits (sticky and dynamic) are filtered by the mask register and then sent to the system interrupt controller. The mask register is controlled by the en/dis interrupt control registers (see Figure 17-4).

Interrupts:

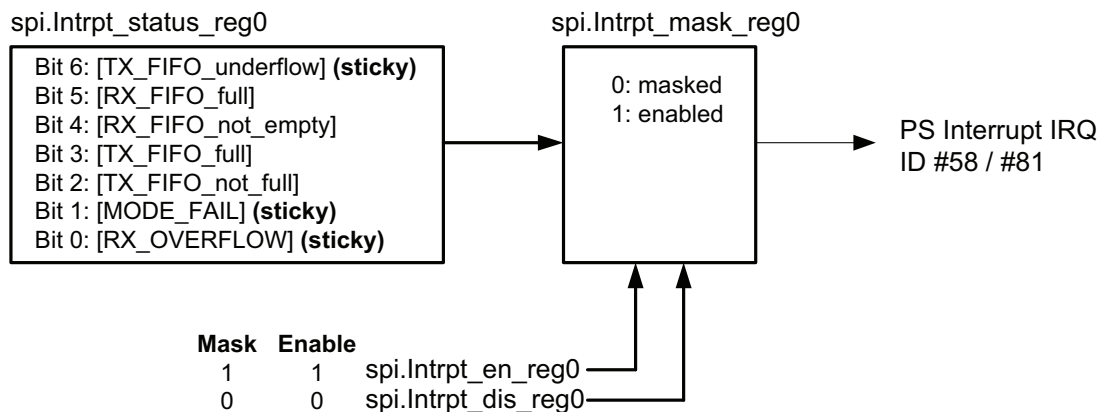

UG585_c17_04_121113

Figure 17-4: SPI Interrupt Register Bits, Logic Flow

17.2.7 SPI-to-SPI Connection

The I/O signals of the two SPI controller in the PC are connected together signals when the slcr.MIO_LOOPBACK [SPI_LOOP_SPI1] bit is set = 1. In this mode, the clock, slave select, MISO, and MOSI signals from one controller are connected to the other controller's clock, slave, MISO, and MOSI signals. respectively.

Limitation

The SPI controller registers require single 32-bit read/write accesses, do not use byte, halfword, or double word references.

17.3 Programming Guide

- [17.3.1 Start-up Sequence](#)
- [17.3.2 Controller Configuration](#)
- [17.3.3 Master Mode Data Transfer](#)
- [17.3.4 Slave Mode Data Transfer](#)
- [17.3.5 Interrupt Service Routine](#)
- [17.3.6 Register Overview](#)

17.3.1 Start-up Sequence

Example: Start-up Sequence

1. **Reset controller:** Assert and de-assert the Ref and CPU_1x resets, refer to section [17.4.1 Resets](#).
2. **Program clocks:** Program the SPI_Ref_Clk, refer to section [17.4.2 Clocks](#).
3. **Tx/Rx signal routing:** Refer to section [17.5 I/O Interfaces](#).
4. **Controller configuration:** Refer to section [17.3.2 Controller Configuration](#).
5. **Interrupt configuration:** Configure the ISR to handle the interrupt conditions. The simplest ISR reads data from the RxFIFO and writes content to the TxFIFO. The PS interrupt controller is described in [Chapter 7, Interrupts](#). The interrupt mechanism for the SPI controller is described in section [17.3.5 Interrupt Service Routine](#).
6. **Start data transfers:**
 - Master Mode operation select: Manual/Auto start and SS, refer to section [17.3.3 Master Mode Data Transfer](#).
 - Slave Mode operation, refer to section [17.3.4 Slave Mode Data Transfer](#).

17.3.2 Controller Configuration

Set controller parameters by writing to the spi.Config_reg register:

- Set baud rate [BAUD_RATE_DIV].
- Set clock phase [CLK_PH] and Polarity [CLK_POL].
- Select Master/Slave mode [MODE_SEL].
- Set Mode fail generation, [Modedefail_gen_en], for multi-master mode systems.
- Set SS to 0b1111 to de-assert all the slave selects before the start of transfers.

Example: SPI 0 Configuration for Master Mode

This example uses a single chip select, a baud rate of 12.5 Mb/s, a clock phase set to inactive, and a clock polarity of quiescent High.

1. **Configure the controller:** Write 0x0002_FC0F to the spi.Config_reg register.
 - a. De-assert all chip selects (for now): [CS] = 1111.
 - b. No external 3-to-8 chip select decoder. [PERI_SEL] = 0.
 - c. Set baud rate to 12.5 Mbps. [BAUD_RATE_DIV] = 1.
This example assumes a 50 MHz SPI_Ref_Clk. Baud rate generator description is in section [17.3.3 Master Mode Data Transfer](#).
 - d. Set clock phase, [CLK_PH] and Polarity, [CLK_POL] to 1. These parameters are discussed in section [17.5.1 Protocol](#).
 - e. Select Master mode: [MODE_SEL] = 1.
 - f. Look for bus collisions: [Modedefail_gen_en] = 1.
 - g. Do not initiate a transmission. [Man_start_com] = 0.

17.3.3 Master Mode Data Transfer

The four combinations of master operating mode are described in section [17.2.1 Master Mode](#). The examples below illustrate the programming steps for each mode.

Example: Master Mode – Manual SS and Manual Start

1. **Enable manual SS:** Write 1 to spi.Config_reg [Manual_CS].
2. **Select manual start:** Write 1 to spi.Config_reg [Man_start_en].
3. **Assert slave select:** Set spi.Config_reg [CS] = 1101 to assert slave select 1.
4. **Enable the controller:** Write 1 to spi.EN_reg0 [SPI_EN].
5. **Write bytes to the TxFIFO:**
 - a. Write the data to the TxFIFO using the register spi.Tx_data_reg.
 - b. Continue to write data to the TxFIFO to its full depth or until no further data is needed to be written.
 - c. Increment the data byte counter in the driver software after each byte is written to the TxFIFO.

6. **Enable the interrupts:** Write `0x27` to `spi.Intrpt_en_reg` to enable RxFIFO full, RxFIFO overflow, TxFIFO empty, and fault conditions.
7. **Start the data transfer:** Set `spi.Config_reg0 [Man_start_com] = 1`.
8. **Wait for interrupts.**
9. **Interrupt handler:** Transfer any additional data to the slave the required data to SPI slave using the interrupt handler.
10. **Disable interrupts:** Write `0x27` to the `spi.Intrpt_dis_reg` to disable RxFIFO full, RxFIFO overflow, TxFIFO empty, and fault conditions.
11. **Disable the controller:** Set `spi.En_reg0 [SPI_EN] = 0`.
12. **De-assert slave select:** Set `spi.Config_reg0 [CS] = 1111`.

Example: Master Mode – Manual SS and Auto Start

1. **Enable manual SS:** Write `1` to `spi.Config_reg [Manual_CS]`.
2. **Assert slave select:** Set `spi.Config_reg [CS] = 1101` to use slave select 1.
3. **Enable the controller:** Write `1` to `spi.EN_reg0 [SPI_EN]`.
4. **Write bytes to the TxFIFO:**
 - a. Write the data to the TxFIFO using the register `spi.Tx_data_reg`.
 - b. Continue to write data to the TxFIFO to its full depth or until no further data is needed to be written.
 - c. Increment the data byte counter in the driver software after each byte is written to the TxFIFO.
5. **Enable the interrupts:** Write `0x27` to `spi.Intrpt_en_reg` to enable RxFIFO full, RxFIFO overflow, TxFIFO empty, and fault conditions.
6. **Wait for interrupts.**
7. **Interrupt handler:** Transfer any additional data to the slave the required data to SPI slave using the interrupt handler.
8. **Disable interrupts:** Write `0x27` to the `spi.Intrpt_dis_reg` to disable RxFIFO full, RxFIFO overflow, TxFIFO empty and fault conditions.
9. **Disable the controller:** Set `spi.En_reg0 [SPI_EN] = 0`.
10. **De-assert slave select:** Set `spi.Config_reg0 [CS] = 1111`.

Example: Master Mode – Auto SS and Manual Start

1. **Select manual start:** Write `1` to `spi.Config_reg0 [Man_start_en]`.
2. **Assert slave select:** Set `spi.Config_reg0 [CS] = 1101` to use slave select 1.
3. **Enable the controller:** Write `1` to `spi.EN_reg0 [SPI_EN]`.
4. **Write bytes to the TxFIFO:**
 - a. Write the data to the TxFIFO using the register `spi.Tx_data_reg`.
 - b. Continue to write data to the TxFIFO to its full depth or until no further data is needed to be written.
 - c. Increment the data byte counter in the driver software after each byte is written to the TxFIFO.

5. **Set the FIFO threshold levels:** Set spi.TX_thres_reg0 and spi.RX_thres_reg0 threshold levels. Refer to the description at “automatic mode of operation” section.
6. **Enable the interrupts:** Write 0x27 to spi.Intrpt_en_reg to enable RxFIFO full, RxFIFO overflow, TxFIFO empty, and fault conditions.
7. **Start the data transfer:** Set spi.Config_reg0 [Man_start_com] = 1.
8. **Interrupt handler:** Transfer any additional data to the slave the required data to SPI slave using the interrupt handler.
9. **Disable interrupts:** Write 0x27 to the spi.Intrpt_dis_reg to disable RxFIFO full, RxFIFO overflow, TxFIFO empty, and fault conditions.
10. **Disable the controller:** Set spi.En_reg0 [SPI_EN] = 0.
11. **De-assert slave select:** Set spi.Config_reg0 [CS] = 1111.

17.3.4 Slave Mode Data Transfer

Example: Slave Mode - Interrupt Driven

Ensure that the controller configuration is done and then:

1. **Slave configuration:** Write 0 to spi_Config_reg0.
2. **Enable the interrupts:** Write 0x37 to spi.Intrpt_en_reg to enable RxFIFO Not empty, RxFIFO full, RxFIFO overflow, TxFIFO empty, and fault conditions.
3. **Enable the controller:** Write 1 to spi.En_reg [SPI_EN].
4. **Interrupt Handler:** Receive data from master using the interrupt handler.
5. **Disable the interrupts:** Write 0x37 to spi.Intrpt_DIS_reg to disable RxFIFO Not empty, RxFIFO full, RxFIFO overflow, TxFIFO empty, and fault conditions.
6. **Disable the controller:** Write 0 to spi_En_reg0 [SPI_EN].

Note: In SPI slave mode operation, it is recommended to set RxFIFO threshold to 1 by setting spi.RX_Thres_reg0[Threshold_of_RX_FIFO] to 1.

17.3.5 Interrupt Service Routine

Example: Interrupt Service Routine

This example handles RxFIFO overflow/underflow, multi-master collision (mode fail) and handles Rx and Tx data transfers.

1. **Disable all interrupts except TxFIFO Full and RxFIFO Not Empty:** Write 0x027 to spi.Intr_dis_REG.
2. **Determine the source of the interrupt:** Read the interrupt status register spi.Intr_status_reg0.
3. **Clear the interrupts:** Write 1s to the interrupt status register spi.Intr_status_reg0.

4. **Check for Mode fail Interrupt:** (multi-master operation). On mode fail, abort the current transfer:
 - a. Reset the controller
 - b. Re-configure the controller
 - c. Re-send the data.
5. **Empty the RxFIFO:** Read spi.Intr_status_reg0 [RX_FIFO_full] bits:
 - a. Read data from the spi.Rx_Data_reg register. Continue to receive bytes using the data byte counter.
6. **Fill the TxFIFO:** More data can be written to the TxFIFO, if needed:
 - a. Write data to the spi.Tx_Data_reg0 register.
 - b. Continue to fill data until FIFO depth is reached or there is no further data.
 - c. Increment the data byte counter after each byte is pushed.
7. **Check for overflow or underflow:** Read the [TX_FIFO_underflow] or [RX_OVERFLOW] status bits. Handle the overflow and underflow conditions accordingly.
8. **Enable the interrupts:** If more data need to be transmitted or received, set spi.Intrpt_en_reg0 [TX_FIFO_not_full] and [RX_FIFO_full] both = 1.
9. **If there is data to be transferred (Sent/Received), then start the data transfer:**
 - When in master mode, and data transfer is done using manual start (for both manual/auto SS), set spi.Config_reg [Man_start_en] = 1.

17.3.6 Register Overview

The SPI registers are detailed [Appendix B, Register Details](#). The register overview is provided in [Table 17-2](#).

Table 17-2: SPI Register Overview

| Type | Register Name | Description |
|--------------------------|-----------------------|---|
| Controller Configuration | Config_reg0 | Configuration |
| Controller enable | En_reg0 | SPI controller enable |
| Interrupt | Intr_status_reg0 | Interrupt status (Rx full, not empty and Tx full, not full) |
| | Intrpt_en_reg0 | Interrupt enable |
| | Intrpt_dis_reg0 | Interrupt disable |
| | Intrpt_mask_reg0 | Interrupt mask/enable |
| FIFO thresholds | TX_thres_reg0 | TxFIFO threshold level for not full |
| | RX_thres_reg0 | RxFIFO Threshold level for not empty |
| Master mode | Delay_reg0 | SS delays and separation counts in master mode |
| FIFO data ports | Tx_data_reg0 | Transmit data (TxFIFO) |
| | Rx_data_reg0 | Receive data (RxFIFO) |
| Slave mode | Slave_Idle_count_reg0 | Slave idle count detects inactive SCLK |

17.4 System Functions

- [17.4.1 Resets](#)
- [17.4.2 Clocks](#)

17.4.1 Resets

The controller has two reset domains: the APB interface and the controller itself. The reset for the two domain must be used together. The effects for each reset type are summarized in [Table 17-3](#).

Table 17-3: SPI Reset Effects

| Name | APB Interface | TxFIFO and Rx FIFO | Protocol Engine | Registers |
|--|---------------|--------------------|-----------------|-----------|
| ABP Interface Reset slcr.SPI_RST_CTRL [SPIx_CPU1X_RST] | Yes | Yes | No | Yes |
| PS Reset Subsystem slcr.SPI_RST_CTRL [SPIx_REF_RST] | No | Yes | Yes | No |

Example: Reset the APB Interface and SPI 0 Controller

1. **Write to the slcr reset register for SPI.** Write a 1, and after some delay write a 0 to the slcr.SPI_RST_CTRL [SPI0_REF_RST] and [SPI0_CPU1X_RST] bit fields.

17.4.2 Clocks

The core of each SPI controller is driven by the same reference clock (SPI_Ref_Clk) that is generated by the PS clock subsystem, [Chapter 25, Clocks](#). The APB interface is clocked by the CPU_1x clock. The CPU_1x clock runs asynchronous to the reference clock. The operating frequency specifications for the controller clocks are defined in the data sheet. The I/O signals are clocked synchronously by the SCLK.

Note: Clock gating is used as power management feature for SPI. Please refer section [24.3.2 Peripherals](#) for more details.

CPU_1x

The CPU_1x clock part of the CPU clock domain, refer section [25.2 CPU Clock](#).

SPI_Ref_Clk

The clock enable, PLL select and divisor settings are programmed using the slcr.SPI_CLK_CTRL register as described in section [25.6.3 SDIO, SMC, SPI, Quad-SPI and UART Clocks](#).

Frequency Restriction Note: The SPI_Ref_Clk must be always be set to a higher frequency than the CPU_1x clock frequency.

Master Mode SCLK

The SCLK is driven by the controller in master mode. It is generated by the a divided-down SPI_Ref_Clk using the spi.Config_reg0 [BAUD_RATE_DIV] bit field.

Frequency Ratio Note: The range of the baud rate divider is from a minimum of 4 to a maximum of 256 in binary steps (i.e., divide by 4, 8, 16,... 256).

Example: SCLK for Master Mode

This example shows how to program the SPI_Ref_Clk to 100 MHz and the SCLK to 25 MHz. The example assumes the I/O PLL is at 1,000 MHz. The CPU_1x clock frequency must be less than 100 MHz.

1. **Program SPI_Ref_Clk:** Select PLL source, divisors and enable: Write `0x0000_0A01` to the `slcr.SPI_CLK_CTRL` register.
 - a. Select the I/O PLL: [SRCSEL] = `00`.
 - b. Divide the I/O PLL clock by 10: [DIVISOR] = `0x0A`.
 - c. Enable the SPI 0 reference clock: [CLKACT0] = `1`.
2. **Program the Baud Rate Generator:** Write `001` to the `spi.Contro_reg0` [BAUD_RATE_DIV] when configuring the controller, refer to section [17.3.2 Controller Configuration](#).

Slave Mode SCLK

The controller clocks the MOSI and SS signals with the SCLK from the external master. These signals are synchronized to the SPI_Ref_Clk and processed by the controller.

Frequency Ratio Note: The SPI_Ref_Clk frequency should be at least 2x the SCLK frequency in order for the controller to properly detect the start of the word transfer on the SPI bus.

17.5 I/O Interfaces

[17.5.1 Protocol](#)

[17.5.2 Back-to-Back Transfers](#)

[17.5.3 MIO/EMIO Routing](#)

[17.5.4 Wiring Connections](#)

[17.5.5 MIO/EMIO Signal Tables](#)

17.5.1 Protocol

Master Mode

The controller supports various I/O signaling relationships for master mode. There are four combinations for setting the phase and polarity control bits, spi.Config_reg0 [CLK_PH] and [CLK_POL]. These parameters affect the active edge of the serial clock, the assertion of the slave select and the idle state of the SCLK.

The clock phase parameter defines the state of the SS between words and the state of SCLK when the controller is not transmitting bits. The phase and polarity parameters are summarized in [Table 17-4](#) and illustrated in [Figure 17-5](#).

Table 17-4: SPI Clock Phase and Polarity Controls

| | CLK_PH = 0 | | CLK_PH = 1 | |
|-----------------------------------|-------------|-------------|-------------|-------------|
| | CLK_POL = 0 | CLK_POL = 1 | CLK_POL = 0 | CLK_POL = 1 |
| Driving Edge | negative | positive | positive | negative |
| Sampling Edge | positive | negative | negative | positive |
| SS State between Words | inactive | | active | |
| SCLK State outside of Word | active | | inactive | |

Clock Phase Setting, CPHA (CLK_PH)

In master mode, the value of the clock phase bit, spi.Config_reg0 [CLK_PH] affects the I/O protocol using parameters in the spi.Delay_reg0 register as follows (see [Figure 17-5](#)):

CLK_PH = 0

- **SS Activity:** The master automatically drives the SS outputs inactive (High) for a the time programmed into the spi.Delay_reg0 [d_nss] bit field: $\text{Time} = (1 + [\text{d_nss}]) * \text{SPI_Ref_Clk}$ clock period. The minimum time is 2 SPI_Ref_Clk clock periods.
- **Delay between Words:** The delay between the last bit period of the current word and the first bit period on the next word: $\text{Time} = (2 + [\text{d_btwn}]) * \text{SPI_Ref_Clk}$ clock period. The minimum time is 3 SPI_Ref_Clk clock periods. This delay enables the TxFIFO to be unloaded and ready for the next parallel-to-serial conversion and to toggle slave select inactive High.

CLK_PH = 1

- **SS Activity:** The SS output signals are not driven inactive between words.
- **Delay between Words:** The minimum delay between the last bit period of the current word and the first bit period on the next word is, by default, one SPI_Ref_Clk cycles (configurable by the spi.Delay_reg0 register). This allows the TxFIFO to be unloaded and ready for the next parallel-to-serial-conversion.

CLK_PH = 0

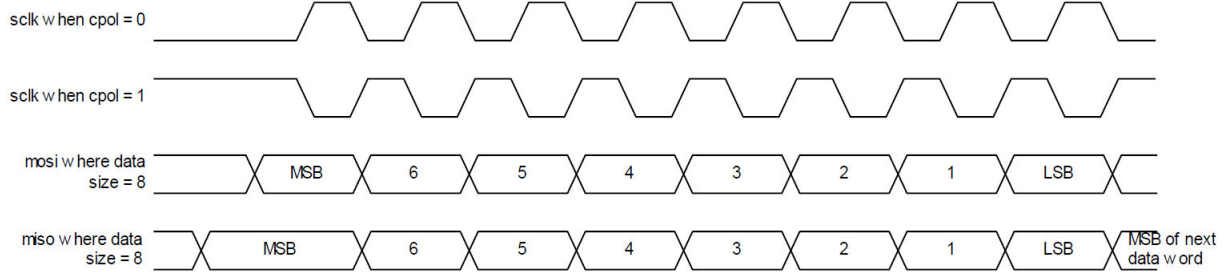

CLK_PH = 1

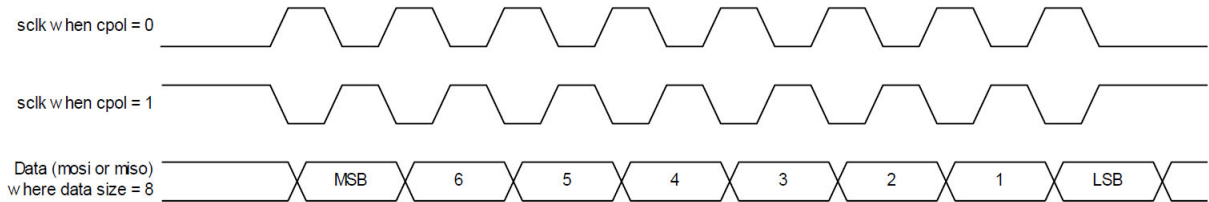

Figure 17-5: SPI I/O Signal Waveforms for Clock Phase and Polarity

17.5.2 Back-to-Back Transfers

(See [Figure 17-6](#).)

Slave Mode Requirements

In slave mode, the controller can accept back-to-back transfers.

Master Mode Options

- Auto SS, auto start (order these four starting with importance and include cross-reference for each)
- Auto SS, manual start
- Manual SS, auto start
- Manual SS, manual start

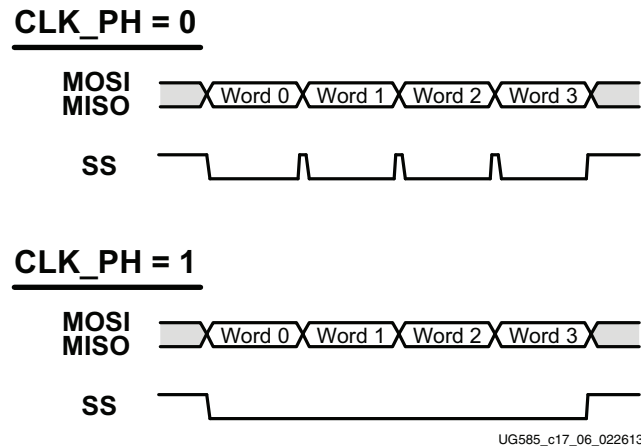

Figure 17-6: SPI Back-to-Back Transfers

17.5.3 MIO/EMIO Routing

The SPI interface signals can be routed either through the MIO pins or the EMIO interface. When the system is reset (e.g., PS_POR_B, PS_SRST_B and other methods), all of the I/O signals are routed to the EMIO interface by default.

The SPI bus can operate up to 50 MHz when the bus signals are routed via the MIO. When the signals are routed via EMIO to the PL pins, the nominal clock rate is 25 MHz. Refer to the frequency specifications that are defined in the data sheet.

To use the EMIO interface, the user must create logic in the PL to directly connect the SPI EMIO interface to PL I/O buffers attached to PL pins. The EMIO route supports up to 25 MHz I/O clocking.

The SPI signals can be routed to specific MIO pins. Wiring diagrams are shown in section [17.5.4 Wiring Connections](#). The general routing concepts and MIO I/O buffer configurations are explained in section [2.5 PS-PL MIO-EMIO Signals and Interfaces](#).

Example: Program the I/O for SPI 0 on to MIO pins 16 to 21

This example enables Master SPI 0 onto pins 16 to 21 using up to three slave selects.

1. **Configure MIO pin 16 for clock output.** Write `0x0000_22A0` to the `slcr.MIO_PIN_16` register.
 - a. Route SPI 0 clock to pin 16.
 - b. Enable output, `[TRI_ENABLE] = 0`.
 - c. LVCMOS18: `[IO_TYPE] = 001`
 - d. Slow CMOS drive edge.
 - e. Disable internal pull-up resistor.
 - f. Disable HSTL receiver.

2. **Configure MIO pins 17 for MISO input.** Write `0x0000_02A0` to each of the `slcr.MIO_PIN_17` register.
 - a. Route SPI 0 MISO to pin 17.
 - b. Disable output. `[TRI_ENABLE] = 1`.
 - c. LVCMOS18: `[IO_TYPE] = 001`.
 - d. Slow CMOS drive edge.
 - e. Disable internal pull-up resistor.
 - f. Disable HSTL receiver.
3. **Configure MIO pin 18, 19 and/or 20 for Slave Select outputs.** Write `0x0000_32A0` to the `slcr.MIO_PIN_18`, 19 and/or 20 registers. The internal pull-up is enabled.
 - a. Route SPI 0 slave selects signal(s) to pins 18, 19 and/or 20. Any and all of the slave selects can be activated for master mode. In slave mode, SS 0 must be used.
 - b. 3-state controlled by SPI: `[TRI_ENABLE] = 0`.
 - c. LVCMOS18: `[IO_TYPE] = 001`.
 - d. Slow CMOS drive edge.
 - e. Enable internal pull-up resistor.
 - f. Disable HSTL receiver.
4. **Configure MIO pins 21 for MOSI.** Write `0x0000_22A0` to each of the `slcr.MIO_PIN_21` register:
 - a. Route SPI 0 MOSI to pin 21.
 - b. 3-state controlled by SPI `[TRI_ENABLE] = 0`.
 - c. LVCMOS18: `[IO_TYPE] = 001`.
 - d. Slow CMOS drive edge.
 - e. Disable internal pull-up resistor.
 - f. Disable HSTL receiver.

17.5.4 Wiring Connections

The user can connect the each SPI controller to external SPI slaves or an SPI master via the MIO pins or the EMIO interface to PL pins. Wiring examples:

- Master Mode via MIO, [Figure 17-7](#)
- Master Mode via EMIO, [Figure 17-8](#)
- Slave Mode via MIO, [Figure 17-9](#)

The I/O signals of the two SPI controllers in the PS can be connected together as described in section [17.2.7 SPI-to-SPI Connection](#).



IMPORTANT: *In master mode, connect SS0 to V_{CC} if SS0 is not used. This is important because the controller snoops this signal in master mode to detect a multi-master mode situation; if SS0 is a logic Low, then the controller assumes multi-master mode and waits for SS0 to de-assert before issuing a transaction.*

Master Mode via MIO

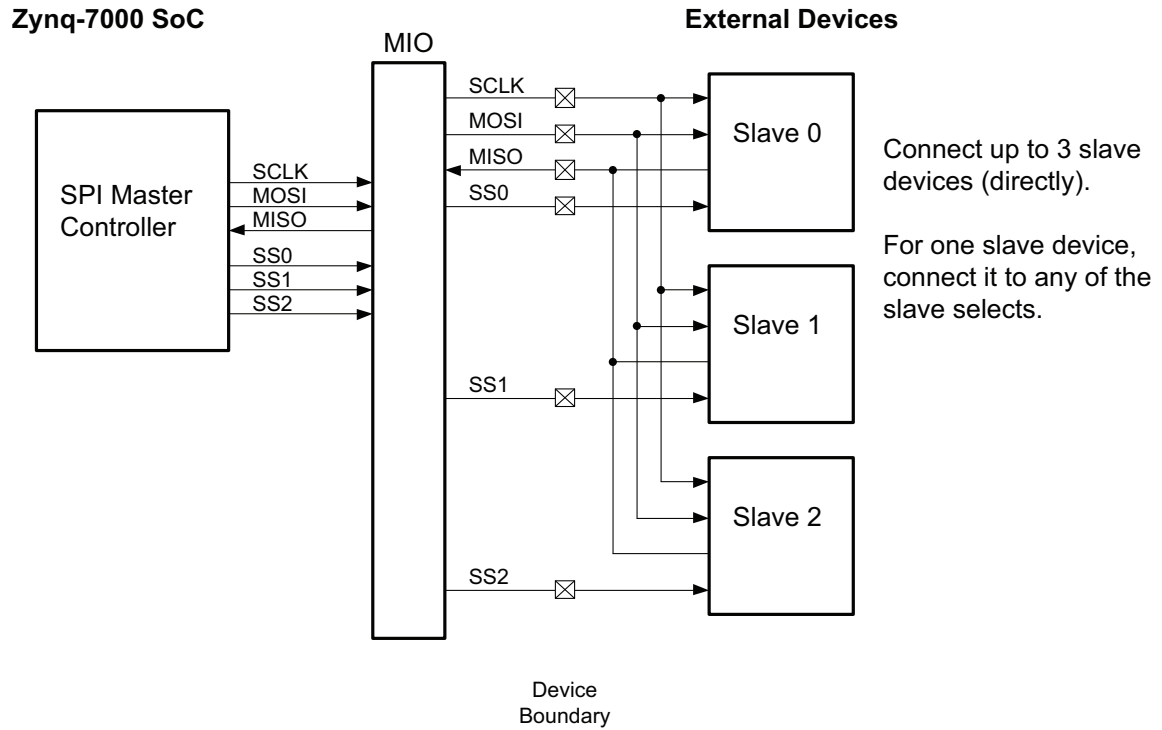
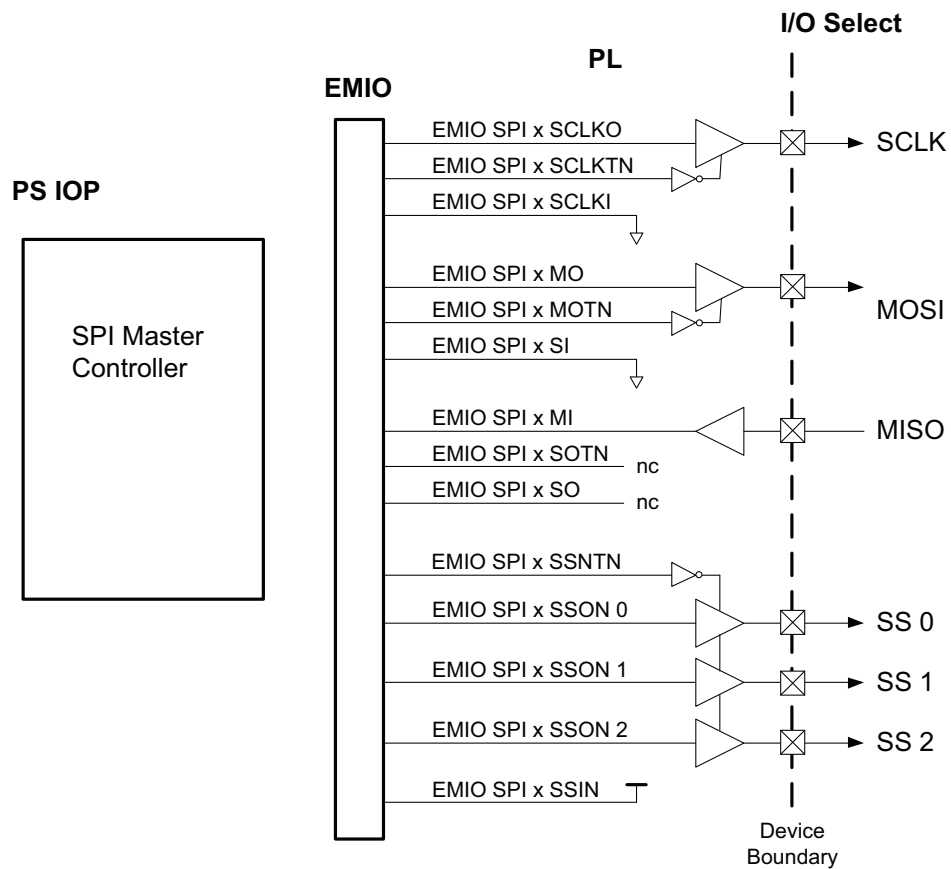

Figure 17-7: SPI Master Mode Wiring Diagram via MIO



IMPORTANT: When using MIO pins always use SS0. For existing designs that do not use SS0, refer to Xilinx [AR58294](#).

Master Mode via EMIO



UG585_c17_08_022613

Figure 17-8: SPI Master Mode Wiring Diagram via EMIO



IMPORTANT: When using EMIO pins, tie SSIN High in the PL bitstream. Ensure that the PS-PL voltage level shifters are enabled, and that the PL is powered and configured. Otherwise the SPI controller will not function properly. For more information about enabling the voltage shift registers, refer to [PS-PL Voltage Level Shifter Enables, page 47](#).

Slave Mode via MIO

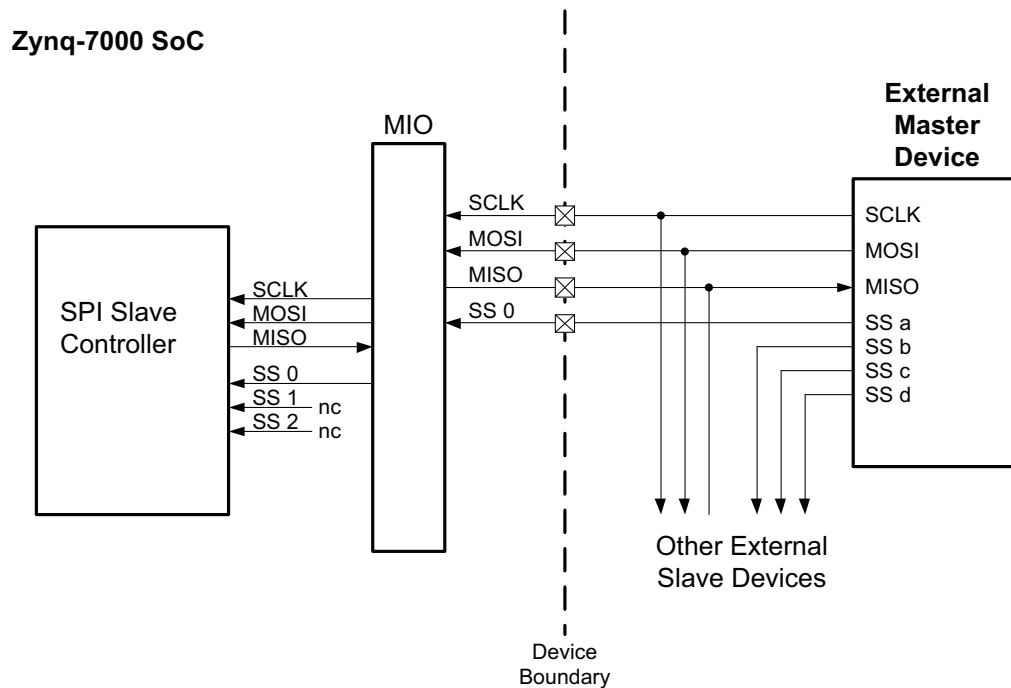

UG585_c17_09_060818

Figure 17-9: SPI Slave Mode Wiring Diagram via MIO

17.5.5 MIO/EMIO Signal Tables

The SPI I/O interface signals routing has some options. The routing options include multiple positions in the MIO pins. The options are illustrated in section 2.5.4 MIO-at-a-Glance Table and in Table 17-5.

Default Input Signal Routing: If the I/O signals are not routed to a set of MIO pins (MIO_PIN_xx register programming), then the EMIO interface input signals are enabled.

MIO Pin Limitation

Small Package Note: The MIO pin restrictions based on device version are shown in the MIO table in section 2.5.4 MIO-at-a-Glance Table. Each SPI I/O interface is selected as a group.

Table 17-5: SPI MIO Pins

| SPI Interface I/O | SPI Signals | | | Slave or Master Mode | Master Mode | |
|--------------------------------|-------------|------|------|----------------------|-------------|------|
| | Clock | MOSI | MISO | SS 0 | SS 1 | SS 2 |
| Signal Type | IO | IO | IO | IO | O | O |
| Controller Default Input Value | 0 | 0 | 0 | 1 | ~ | ~ |
| SPI 0, choice 1 | 16 | 21 | 17 | 18 | 19 | 20 |
| SPI 0, choice 2 | 28 | 33 | 29 | 30 | 31 | 32 |
| SPI 0, choice 3 | 40 | 45 | 41 | 42 | 43 | 44 |
| SPI 1, choice 1 | 12 | 10 | 11 | 13 | 14 | 15 |
| SPI 1, choice 2 | 24 | 22 | 23 | 25 | 26 | 27 |
| SPI 1, choice 3 | 36 | 34 | 35 | 37 | 38 | 39 |
| SPI 1, choice 4 | 48 | 46 | 47 | 49 | 50 | 51 |

EMIO Signals

The SPI I/O interface signals available on the EMIO interface are identified in [Table 17-6](#).

Table 17-6: SPI EMIO Signals

| SPI Interface | Controller Default Input Value | EMIO Signals | | |
|----------------------|--------------------------------|----------------|-----------------|------------------|
| | | Input Name (I) | Output Name (O) | 3-state Name (O) |
| SPI 0 Clock | 0 | EMIOSPI0SCLKI | EMIOSPI0SCLKO | EMIOSPI0SCLKTN |
| SPI 0 MOSI | 0 | EMIOSPI0SI | EMIOSPI0MO | EMIOSPI0MOTN |
| SPI 0 MISO | 0 | EMIOSPI0MI | EMIOSPI0SO | EMIOSPI0STN |
| SPI 0 Slave Select 0 | 1 | EMIOSPI0SSIN | EMIOSPI0SSON0 | |
| SPI 0 Slave Select 1 | ~ | | EMIOSPI0SSON1 | |
| SPI 0 Slave Select 2 | ~ | | EMIOSPI0SSON2 | |
| SPI 0 SS 3-state | ~ | | | EMIOSPI0SSNTN |
| SPI 1 Clock | 0 | EMIOSPI1SCLKI | EMIOSPI1SCLKO | EMIOSPI1SCLKTN |
| SPI 1 MOSI | 0 | EMIOSPI1SI | EMIOSPI1MO | EMIOSPI1MOTN |
| SPI 1 MISO | 0 | EMIOSPI1MI | EMIOSPI1SO | EMIOSPI1STN |
| SPI 1 Slave Select 0 | 1 | EMIOSPI1SSIN | EMIOSPI1SSON0 | |
| SPI 1 Slave Select 1 | ~ | | EMIOSPI1SSON1 | |
| SPI 1 Slave Select 2 | ~ | | EMIOSPI1SSON2 | |
| SPI 1 SS 3-state | ~ | | | EMIOSPI1SSNTN |

CAN Controller

18.1 Introduction

This chapter describes the architecture and features of the CAN controllers and the functions of the various registers in the design. There are two nearly identical CAN controllers in the PS that are independently operable. Defining the CAN protocol is outside the scope of this document, and knowledge of the specifications is assumed.

18.1.1 Features

CAN Controller features are summarized as follows:

- Compatible with the *ISO 11898 -1*, *CAN 2.0A*, and *CAN 2.0B* standards
- Standard (11-bit identifier) and extended (29-bit identifier) frames
- Bit rates up to 1 Mb/s
- Transmit message FIFO (TxFIFO) with a depth of 64 messages
- Transmit prioritization through one high-priority transmit buffer (TxHPB)
- Watermark interrupts for TxFIFO and RxFIFO
- Automatic re-transmission on errors or arbitration loss in normal mode
- Receive message FIFO (RxFIFO) with a depth of 64 messages
- Four Rx acceptance filters with enables, masks and IDs
- Loopback and snoop modes for diagnostic applications
- Maskable error and status interrupts
- 16-Bit time stamping for receive messages
- Readable Rx/Tx error counters

18.1.2 System Viewpoint

The system viewpoint of the CAN controller is shown in Figure 18-1.

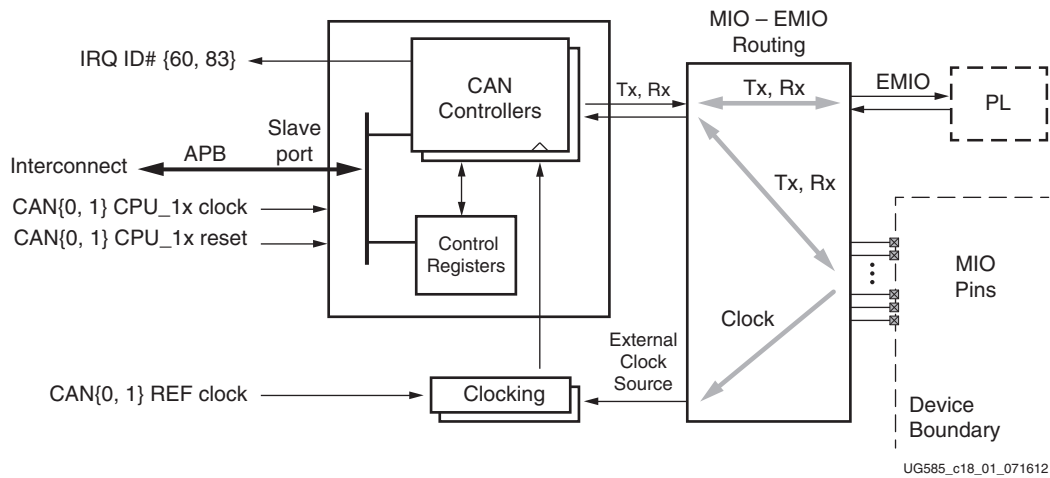

Figure 18-1: CAN Controller System Viewpoint

18.1.3 Block Diagram

The high-level architecture of the CAN core is shown in Figure 18-2. The sub-modules are described in subsequent sections.

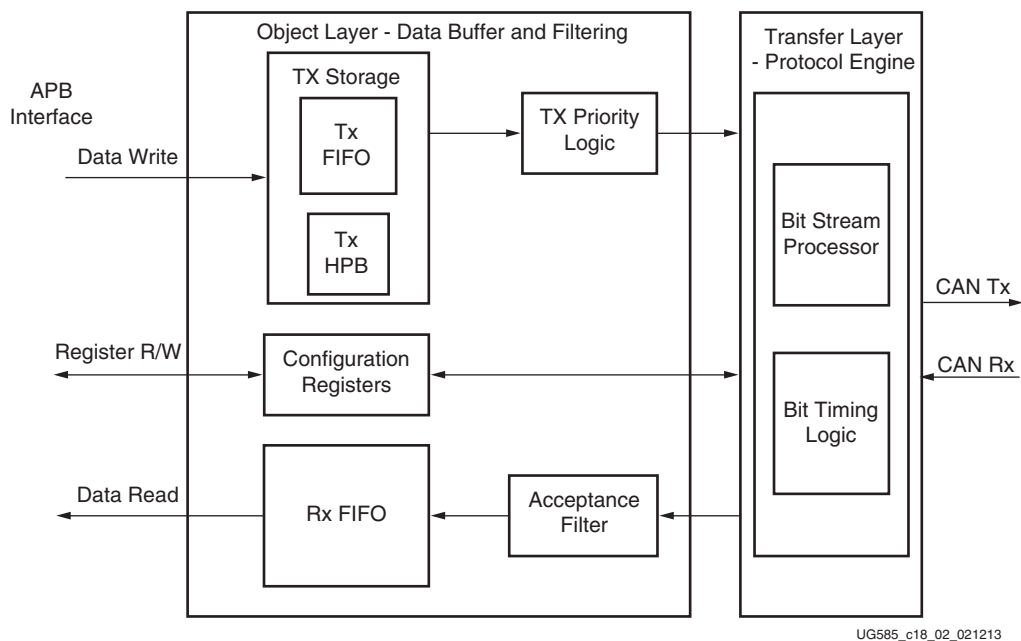

Figure 18-2: CAN Controller Block Diagram

Configuration Registers

The CAN Controller Configuration register defines the configuration registers. This module allows for read and write access to the registers through the APB interface. An overview of the CAN controller registers are shown in section [18.3.8 Register Overview](#).

Transmit and Receive Messages

Separate storage buffers exist for transmit (TxFIFO) and receive (Rx FIFO) messages through a FIFO structure. Each buffer can store up to 64 messages. Once a message is written into the TxFIFO it takes a total delay of $2 \times (\text{Tx Driver delay} + \text{Propagation delay} + \text{Rx Driver delay})$ to transmit over the CAN bus.

Tx High Priority Buffer

Each controller also has a transfer high priority buffer (TxHPB) provides storage for one transmit message. Messages written on this buffer have maximum transmit priority. They are queued for transmission immediately after the current transmission is complete, preempting any message in the TxFIFO.

Acceptance Filters

Acceptance filters sort incoming messages with the user-defined acceptance mask and ID registers to determine whether to store messages in the Rx FIFO, or to acknowledge and discard them. Messages passed through acceptance filters are stored in the Rx FIFO.

18.1.4 Notices

Restrictions

There is a single PS clock generator for both controllers. When the internal clock is used, it will be of the same clock frequency, but the clock to each controller can be individually enabled using the slcr register, see section [The Quad-SPI clock is divided down by at least two using the Quad-SPI baud rate divider, see section 12.4.1 Clocks. In master mode, the SPI clock is divided down by at least four using the SPI baud rate divider, see section 17.4.2 Clocks.](#) Also, either or both controllers can be clocked from an external source via an MIO pin, see section [18.4.1 Clocks](#).



RECOMMENDED: For all clocking sources, set the `can.BRPR` register to a value of 2 or greater and a prescaler value of at least 3.

18.2 Functional Description

Each controller is independently configured and controlled. There are two CAN controllers (CAN_x; where x = 0 or 1). The register name preface for the CAN registers is 'can' (e.g., can.MSR register).

18.2.1 Controller Modes

The CAN controller supports the following modes of operation:

- Configuration
- Normal
- Sleep
- Loop Back
- Snoop mode

Configuration Mode

The CAN controller enters the Configuration mode when any of the following actions are performed, regardless of the operation mode:

- Writing a 0 to the CEN bit in the SRR register.
- Writing a 1 to the SRST bit in the SRR register. The core enters the Configuration mode immediately following the software reset.
- Driving a 0 on the reset input. The core continues to be in reset as long as reset is 0. The core enters Configuration mode after reset is negated to 1.

Normal Mode

Normal mode transmits and receives messages on the Tx and Rx I/O signals as defined by the Bosch and IEEE specifications.

Sleep Mode

Sleep mode can be used to save a small amount of power during idle times. When in sleep mode, the controller can transition to normal mode or configuration mode. In sleep mode:

- When another node transmits a message, the controller receives the message and exits sleep mode.
- If there is a new Tx request then the hardware switches the controller to normal mode and the controller services the request(s).
- An interrupt can be generated when the controller enters sleep mode.
- An interrupt can be generated when the controller wakes up.

Sleep mode is exited by the hardware when there is CAN bus activity or a request in either TxFIFO or

TxHPB. When the controller exits sleep mode, `can.MSR[SLEEP]` is set to 0 by the hardware and an interrupt can be generated.

The CAN controller enters Sleep mode from Configuration mode when the LBACK bit in MSR is 0, the SLEEP bit in MSR is 1, and the CEN bit in SRR is 1. The CAN controller enters Sleep mode only when there are no pending transmission requests from either the TX FIFO or the TX High Priority Buffer.

The CAN controller enters Sleep mode from Normal mode only when the SLEEP bit is 1, the CAN bus is idle, and there are no pending transmission requests from either the TX FIFO or TX High Priority Buffer.

When another node transmits a message, the CAN controller receives the transmitted message and exits Sleep mode. When the controller is in Sleep mode, if there are new transmission requests from either the TX FIFO or the TX High Priority Buffer, these requests are serviced, and the CAN controller exits Sleep mode. Interrupts are generated when the CAN controller enters Sleep mode or wakes up from Sleep mode. From sleep mode, the CAN controller can enter either the Configuration or Normal modes.

Loop Back Mode (Diagnostics)

Loop back mode is used for diagnostic purposes. When in loop back mode, the controller must only be programmed to enter configuration mode or issue reset. In loop back mode:

- The controller transmits a recessive bitstream onto the CAN_TX bus signal.
- Tx messages are internally looped back to the Rx line and are acknowledged.
- Tx messages are not sent on the CAN_TX bus signal.
- The controller receives all message that it transmits.
- The controller does not receive any messages transmitted by other CAN nodes.

Snoop Mode (Diagnostics)

Snoop mode is used for diagnostic purposes. When in snoop mode, the controller must only be programmed to enter configuration mode or be held in reset. In snoop mode:

- The controller transmits a recessive bitstream onto the CAN bus.
- The controller does not participate in normal bus communication.
- The controller receives messages that are transmitted by other CAN nodes.
- Software can program acceptance filters to dynamically enable/disable and change criteria. Error counters are disabled and cleared to 0. Reads to error counter registers return 0.

Mode Transitions

The supported mode transitions are shown in [Figure 18-3](#). The transitions are primarily controlled by the resets, the CEN bit, the MSR register settings, and a hardware wake-up mechanism.

To enter normal mode from configuration mode:

- Clear `can.MSR[LBACK, SNOOP, SLEEP] = 0`

- Set `can.SRR[CEN] = 1`

To enter sleep mode from normal mode (interrupt generated):

- Set `can.MSR[SLEEP] = 1`

Events that cause the controller to exit sleep mode (interrupt generated):

- Rx signal activity (hardware sets `can.MSR[SLEEP] = 0`)
- Tx FIFO or TxHPB activity (hardware sets `can.MSR[SLEEP] = 0`)
- Software writes 0 to `can.MSR[SLEEP]`

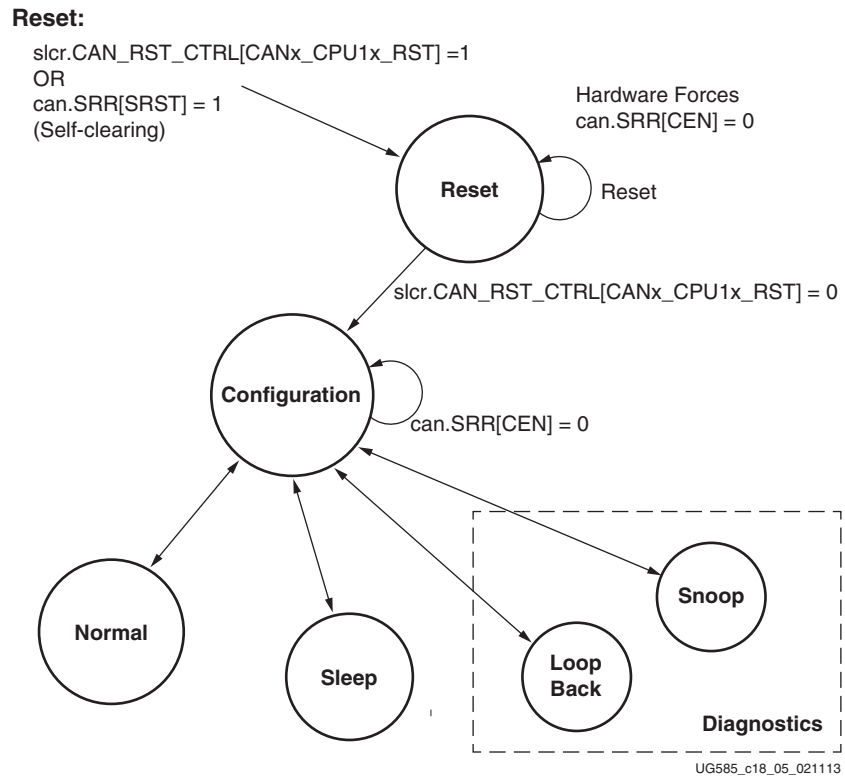

Figure 18-3: CAN Operating Mode Transitions

Mode Settings

Table 18-1 defines the CAN controller modes of operation and corresponding control and status bits.

Table 18-1: CAN Controller Modes of Operation

| CAN CPU_1x PS Reset (slcr) | Software Reset Register (can.SRR) | | Mode Select Register (MSR) (Read/Write bits) | | | Status Register (SR) (Read Only bits) | | | | | Operational Mode |
|----------------------------|-----------------------------------|------------------|--|-------|-------|---------------------------------------|-------|-------|--------|-------|------------------|
| | SRST (CAN Reset) | CEN (CAN Enable) | LBACK | SLEEP | SNOOP | CONFIG | LBACK | SLEEP | NORMAL | SNOOP | |
| 1 | X | X | X | X | X | 1 | 0 | 0 | 0 | 0 | Reset |
| 0 | 1 | X | X | X | X | 1 | 0 | 0 | 0 | 0 | Reset |

Table 18-1: CAN Controller Modes of Operation (Cont'd)

| CAN CPU_1x PS Reset (slcr) | Software Reset Register (can.SRR) | | Mode Select Register (MSR) (Read/Write bits) | | | Status Register (SR) (Read Only bits) | | | | | Operational Mode |
|----------------------------|-----------------------------------|------------------|--|-------|-------|---------------------------------------|-------|-------|--------|-------|------------------|
| | SRST (CAN Reset) | CEN (CAN Enable) | LBACK | SLEEP | SNOOP | CONFIG | LBACK | SLEEP | NORMAL | SNOOP | |
| 0 | 0 | 0 | X | X | X | 1 | 0 | 0 | 0 | 0 | Configuration |
| 0 | 0 | 1 | 1 | X | X | 0 | 1 | 0 | 0 | 0 | Loop back |
| 0 | 0 | 1 | 0 | 1 | 0 | 0 | 0 | 1 | 0 | 0 | Sleep |
| 0 | 0 | 1 | 0 | 0 | 1 | 0 | 0 | 0 | 1 | 1 | Snoop |
| 0 | 0 | 1 | 0 | 0 | 0 | 0 | 0 | 0 | 1 | 0 | Normal |

18.2.2 Message Format

The same message format is used for Rx FIFO and Tx (FIFO and HPB). Each message includes four words (16 bytes). Software must read and write all four words regardless of the actual number of data bytes and valid fields in the message.

The message words, fields and structure are shown in Table 18-2. The details of each field are in Table 18-3.

Table 18-2: CAN Message Format

| | 31 | 30 | 29 | 28 | 27 | 26 | 25 | 24 | 23 | 22 | 21 | 20 | 19 | 18 | 17 | 16 | 15 | 14 | 13 | 12 | 11 | 10 | 9 | 8 | 7 | 6 | 5 | 4 | 3 | 2 | 1 | 0 |
|--------------------------|-----------|----|----|----------|----|----|----|----------|----|----|----|---------|-----|----------|---------------------------------------|----|----|----|----|----|----|----------|---|---|-----|---|---|---|---|---|---|---|
| Message Identifier [IDR] | ID[28:18] | | | | | | | | | | | STR/RTR | IDE | ID[17:0] | | | | | | | | | | | RTR | | | | | | | |
| Data Length Code [DLCR] | DLC[3:0] | | | Reserved | | | | | | | | | | | Time Stamp (Rx only, Reserved for Tx) | | | | | | | | | | | | | | | | | |
| Data Word 1 [DW1R] | DB0[7:0] | | | | | | | DB1[7:0] | | | | | | | DB2[7:0] | | | | | | | DB3[7:0] | | | | | | | | | | |
| Data Word 2 [DW2R] | DB4[7:0] | | | | | | | DB5[7:0] | | | | | | | DB6[7:0] | | | | | | | DB7[7:0] | | | | | | | | | | |

Bit Field Details

Writes

If a bit field or data byte is not required, then write zeros. Software should write the default values shown in Table 18-3 for unused functions.

Reads

Data starts at byte 0 and continues for the number of counts in DLC. Software should read both data words, but the only valid bytes are determined by DLC.

Table 18-3 provides bit descriptions for the identifier word bits, the DLC word bits, and data word 1 and data word 2 bits.

Table 18-3: CAN Message Word Register Bit Fields

| Bits | Name | Default Value | Description |
|------------------------|-----------|---------------|--|
| Identifier Word | | | |
| 31:21 | ID[28:18] | 0 | Standard Message ID The identifier portion for a standard frame is 11 bits. These bits indicate the standard frame ID. This field is valid for both standard and extended frames. |
| 20 | SRR/RTR | 0 | Substitute Remote Transmission Request This bit differentiates between data frames and remote frames. Valid only for standard frames. For extended frames this bit is 1. 1: Indicates that the message frame is a Remote Frame. 0: Indicates that the message frame is a Data Frame. |
| 19 | IDE | 0 | Identifier Extension This bit differentiates between frames using the Standard Identifier and those using the Extended Identifier. Valid for both Standard and Extended Frames. 1: Indicates the use of an extended message identifier. 0: Indicates the use of a standard message identifier. |
| 18:1 | ID[17:0] | 0 | Extended Message ID This field indicates the extended identifier. Valid only for extended frames. For standard frames, reads from this field return 0s. For Standard frames, writes to this field should be 0s. |
| 0 | RTR | 0 | Remote Transmission Request This bit differentiates between data frames and remote frames. Valid only for extended frames. 1: Indicates the message object is a remote frame. 0: Indicates the message object is a data frame. For standard frames, reads from this bit returns 0. For standard frames, writes to this bit should be 0. |
| DLC Word | | | |
| 31-28 | DLC | 0 | Data Length Code This is the data length portion of the control field of the CAN frame. This indicates the number valid data bytes (0 to 8) that are in the Data Word 1 and Data Word 2 registers. |

Table 18-3: CAN Message Word Register Bit Fields (Cont'd)

| Bits | Name | Default Value | Description |
|--------------------|----------|---------------|--|
| 27-0 | Reserved | 0 | Reads from this field return 0s. Writes to this field should be 0s. |
| Data Word 1 | | | |
| DW1R[31:24] | DB0[7:0] | 0 | Data Byte 0 |
| DW1R[23:16] | DB1[7:0] | 0 | Data Byte 1 |
| DW1R[15:8] | DB2[7:0] | 0 | Data Byte 2 |
| DW1R[7:0] | DB3[7:0] | 0 | Data Byte 3 |
| Data Word 2 | | | |
| DW2R[31:24] | DB4[7:0] | 0 | Data Byte 4 |
| DW2R[23:16] | DB5[7:0] | 0 | Data Byte 5 |
| DW2R[15:8] | D6[7:0] | 0 | Data Byte 6 |
| DW2R[7:0] | DB7[7:0] | 0 | Data Byte 7 |

18.2.3 Message Buffering

Rx Messages

The RxFIFO can store up to 64 Rx CAN messages that are received and optionally filtered. Rx messages that pass any of the acceptance filters are stored in the RxFIFO. When no acceptance filter has been selected, all received messages are stored in the RxFIFO. Software reads these messages as described in [18.3.7 Read Messages from RxFIFO](#).

A timestamp is added to each successfully stored Rx message. A free running 16-bit counter is clocked using the CAN bit time clock. The rules for time stamping an Rx message are:

- The counter rolls over. There is no status bit to indicate that the roll over condition occurred.
- The timestamp included when a Rx message is successfully collected. The sampling of the counter takes place at the last bit of EOF.
- The counter is cleared when CEN=0 or by software writing a 1 to the can.TCR register.

Software must read all four registers of an Rx message in the RxFIFO, regardless of how many data bytes are in the message. The first word is read using the RXFIFO_ID register and contains the identifier of the received message (IDR). The second word is read using the RXFIFO_DLC register and contains the 16-bit timestamp and data length code (DLC) field. The third and fourth words contain data word 1 (DW1R) and data word 2 (DW2R).

Writes to the RxFIFO registers are ignored. Read data from an empty RxFIFO are invalid and might generate an interrupt.

The messages in the RxFIFO are retained even if the CAN controller enters Bus off state or Configuration mode.

Tx Messages

The controller has a configurable TxFIFO that software can use buffer up to 64 Tx CAN messages. The controller also has a high priority transmit buffer (Tx HPB), with storage for one message. When a higher priority message needs to be sent, software writes the message to the high priority transmit buffer when it is available. The message in the TxHPB has higher priority over messages in the TxFIFO.

When arbitration loss or errors occur during the transmission of a message, the controller tries to retransmit the message. No subsequent message, even a newer, higher priority message is transmitted until the original message is transmitted without errors or arbitration loss.

The controller transmits the message starting with bit 31 of the IDR word. After the identifier word is transmitted, the DLCR word is transmitted. This is followed by the data bytes in this order: DB0, DB1, ... DB7. The last bit in the data portion of the message is DB7, bit 0. See [Table 18-2, page 560](#).

The status bit, `can.ISR[TXOK]` is set = 1 after the controller successfully transmits a message from either the TxFIFO or TxHPB.

The messages in the TxFIFO and TxHPB are retained even if the CAN controller enters Bus off state or Configuration mode.

The message format is described in [18.2.2 Message Format](#).

Reads from RxFIFO

All 16 bytes must be read from the RxFIFO to receive the complete message. The first word read (4 bytes) returns the identifier of the received message (IDR). The second read returns the 16-bit receive time stamp and data length code (DLC) field of the received message (DLCR). The third read returns data word 1 (DW1R), and the fourth read returns data word 2 (DW2R).

A free running 16-bit counter provides a time stamp relative to the time the message was successfully received.

All four words must be read for each message, even if the message contains less than eight data bytes. Write transactions to the RxFIFO are ignored. Reads from an empty RxFIFO return invalid data and generates an Rx Underflow interrupt.

Rx and Tx Error Counters

When an Rx or Tx error occurs, the associated error counters in the protocol engine (see section [18.2.6 Protocol Engine](#)) are incremented. The two error counters are 8 bits wide and are read using the read-only `can.ECR` register, bit fields REC and TEC.

The Rx and Tx counters are reset when any the these situations occur:

- After a 1 is written to `can.SRR[SRST]` field = 1. This bit write is self-clearing.
- Anytime `can.SRR[CEN]` = 0 (configuration mode).
- When the controller enters Bus Off state.

18.2.4 Interrupts

Each CAN controller has a single interrupt signal to the GIC interrupt controller. CAN 0 connects to IRQ ID#60 and CAN 1 connects to ID #83. The source of an interrupt can be grouped into one of the following:

- TxFIFO and TxHPB
- RxFIFO
- Message passing and arbitration
- Sleep mode and bus off

Enable and disable interrupts using the can.IER register. Check the raw status of the interrupt using can.ISR. Clear interrupts by writing a 1 to can.ICR. Some interrupt sources have an additional method to clear the interrupt as shown in [Table 18-4](#).

List of Interrupts

All of the CAN interrupts are sticky; that is, once the hardware sets them they stay set until cleared by software. CAN status and interrupts are identified in [Table 18-4](#).

Table 18-4: List of CAN Status and Interrupts

| Name | Bit Number | Additional Method to Clear Interrupt | Usage |
|------------------|------------|--------------------------------------|--|
| TxFIFO Watermark | 13 | none | Operational threshold. |
| TxFIFO Empty | 14 | none | Empty indicator. |
| TxFIFO Full | 2 | none | Full indicator. |
| TxHPB Full | 3 | none | This status indicates if the buffer is in-use and should not be written. |
| RxFIFO Watermark | 12 | none | Operational threshold. |
| RxFIFO Not Empty | 7 | none | One or more messages can be read. |
| RxFIFO overflow | 6 | Write 0 to can.SRR[CEN] | FIFO was full and message(s) likely lost. |
| RxFIFO underflow | 5 | none | Programming error, message read from RxFIFO when no messages were there. |
| Message Rx | 4 | Write 0 to can.SRR[CEN] | |
| Message Tx | 1 | Write 0 to can.SRR[CEN] | |
| Message Error | 8 | Write 0 to can.SRR[CEN] | Any of the five CAN errors in the Error Status register. |
| Arbitration Lost | 0 | none | |
| Enter Sleep Mode | 10 | Write 0 to can.SRR[CEN] | |

Table 18-4: List of CAN Status and Interrupts

| Name | Bit Number | Additional Method to Clear Interrupt | Usage |
|-----------------|------------|--------------------------------------|--|
| Exit Sleep Mode | 11 | Write 0 to can.SRR[CEN] | Controller can go to normal or configuration mode. |
| Bus Off | 9 | Write 0 to can.SRR[CEN] | |

RxFIFO and TxFIFO Interrupts

The FIFO watermark levels and all the FIFO interrupts are illustrated in Figure 18-4, CAN RxFIFO and TxFIFO Watermark Interrupts.

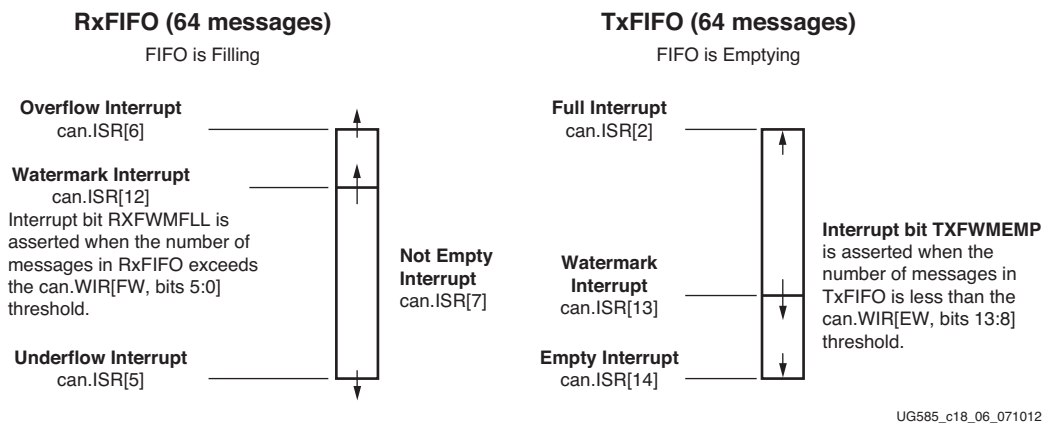

Figure 18-4: CAN RxFIFO and TxTxFIFO Watermark Interrupts

Example: Program RxFIFO Watermark Interrupt (12)

The following steps can be used to setup and control the RxFIFO watermark interrupt. See Figure 18-4. The watermark status and control interrupts are described in Protocol Engine, page 569.

1. **Disable RxFIFO watermark interrupt.** Write a 0 to can.IER[12].
2. **Program RxFIFO full watermark level.** Write to can.WIR[FW].
3. **Clear RxFIFO watermark interrupt.** Write a 1 to can.ICR[12].
4. **Read RxFIFO watermark status.** Read can.ISR[12].
5. **Enable RxFIFO watermark interrupt.** Write a 1 to can.IER[12].

Example: Program TxTxFIFO Watermark Interrupt (13)

The following steps can be used to setup and control the TxTxFIFO watermark interrupt. See Figure 18-4. The watermark status and control interrupts are described in Protocol Engine, page 569.

1. **Disable TxTxFIFO watermark interrupt.** Write a 0 to can.IER[13].
2. **Program TxTxFIFO empty watermark level.** Write to can.WIR[EW].

3. **Clear TxFIFO watermark interrupt.** Write a 1 to can.ICR[13].
4. **Read TxFIFO watermark status.** Read can.ISR[13].
5. **Enable TxFIFO watermark interrupt.** Write a 1 to can.IER[13].

Example: Program TxFIFO Empty Interrupt (14)

The following steps can be used to control the TxFIFO empty interrupt:

1. **Disable TxFIFO empty interrupt.** Write a 1 to can.IER[14].
2. **Clear TxFIFO empty interrupt.** Write a 1 to can.ICR[14].
3. **Enable TxFIFO empty interrupt.** Write a 1 to can.IER[14].
4. **Read TxFIFO empty status.** Read can.ISR[14]. It indicates the status whether TxFIFO is empty or not.

18.2.5 Rx Message Filtering

To filter Rx messages, configure and enable up to four acceptance filters with acceptance mask and ID registers to determine whether to store messages in the RxFIFO, or to acknowledge and discard them.

Acceptance filtering is performed in the following sequence:

1. The incoming identifier is masked with the bits in the Acceptance Filter Mask register.
2. The Acceptance Filter ID register is also masked with the bits in the Acceptance Filter Mask register.
3. Both resulting values are compared.
4. If both these values are equal, then the message is stored in the RxFIFO.
5. Acceptance filtering is processed by each of the defined filters. If the incoming identifier passes through any acceptance filter, then the message is stored in the RxFIFO.

Acceptance Filter Enable

The Acceptance Filter register (AFR) defines which acceptance filters to use. It includes four enable bits that correspond to the four acceptance filters. Each Acceptance Filter ID register (AFIR) and Acceptance Filter Mask register (AFMR) pair is associated with a use acceptance filter (UAF) bit.

When the UAF bit is 1, the corresponding acceptance filter pair is used for acceptance filtering. When the UAF bit is 0, the corresponding acceptance filter pair is not used for acceptance filtering.

To modify an acceptance filter pair in normal mode, the corresponding UAF bit in this register must first be set to 0. After the acceptance filter is modified, the corresponding UAF bit must be set to 1 for the filter to be enabled.

The UAF bits in the can.AFR register enable the Rx acceptance filters:

- If all UAF bits are set to 0, then all received messages are stored in the RxFIFO.
- If the UAF bits are changed from a 1 to 0 during reception of a CAN message, the message will not be stored in the RxFIFO.

If any of the enabled filters (up to four) satisfy this equation, then the Rx message is stored in the Rx FIFO:

If $(AFMR \& Message_ID) == (AFMR \& AFIR)$ then Capture Message

Each acceptance filter is independently enabled. The filters are selected by the can.AFR register.

- Set can.AFR[UAF4] = 1 to enable AFMR4 and AFID4.
- Set can.AFR[UAF3] = 1 to enable AFMR3 and AFID3.
- Set can.AFR[UAF2] = 1 to enable AFMR2 and AFID2.
- Set can.AFR[UAF1] = 1 to enable AFMR1 and AFID1.

If all can.AFR[UAFx] bits are set = 0, then all received messages are stored in the Rx FIFO. The UAF bits are sampled by the hardware at the start of an incoming message.

Acceptance Filter Mask

The Acceptance Filter Mask registers (AFMR) contain mask bits used for acceptance filtering. The incoming message identifier portion of a message frame is compared with the message identifier stored in the Acceptance Filter ID register. The mask bits define which identifier bits stored in the Acceptance Filter ID register are compared to the incoming message identifier.

There are four AFMRs. These registers are stored in a memory. Reads from AFMRs return 'X's if the memory is uninitialized. Asserting a software reset or hardware reset does not clear register contents. These registers can be read from and written to. These registers are written to only when the corresponding UAF bits in the can.AFR register are 0 and the ACFBSY bit in the can.SR register is 0.

The following conditions govern AFMRs:

Extended Frames All bit fields (AMID [28:18], AMSRR, AMIDE, AMID [17:0] and AMRTR) need to be defined.

Standard Frames Only AMID [28:18], AMSRR and AMIDE need to be defined. AMID [17:0] and AMRTR should be written as 0.

Acceptance Filter Identifier

The Acceptance Filter ID registers (AFIR) contain Identifier bits, which are used for acceptance filtering. There are four Acceptance Filter ID registers.

These registers can be read from and written to. These registers should be written to only when the corresponding UAF bits in the SR are 0 and the ACFBSY bit in the SR is 0.

The following conditions govern the use of the AFIRs:

Extended Frames All the bit fields (AIID [28..18], AISRR, AIIDE, AIID [17:0] and AIRTR) must be defined.

Standard Frames Only AIID [28:18], AISRR and AIIDE need to be defined. AIID [17:0] and AIRTR should be written with 0.

The user must ensure proper programming of the IDE bit for standard and extended frames. If the user sets the IDE bit in AMIR to 0, then it is considered to be a standard frame ID check only.

Example: Program Acceptance Filter

Each acceptance filter has its own mask, can.AFMR{1,2,3,4}, and ID register, can.AFIR{1,2,3,4}.

1. **Disable acceptance filters.** Write 0 to the can.AFR register.
2. **Wait for filter to be not busy.** Poll on can.SR[ACFBSY] for 0.
3. **Write a filter mask and ID.** Write to a pair of AFMR and AFIR registers (refer to the example below).
4. **Write additional filter masks and IDs.** Go to step 2.
5. **Enable one or more Filters.** To enable all filters, write 0x0000_000F to the can.AFR register.

Program the AFMR and AFIR Registers

The valid fields for sending Tx messages to the controller are summarized in [Table 18-5](#). These fields are described in section [18.2.2 Message Format](#).

Table 18-5: CAN Message Identifier Register (IDR) Fields

| | ID[28:18] | STR/RTR | IDE | ID[17:0] | RTR |
|-----------------------|-----------|---------|-------|----------|---------|
| Standard Frame | Valid | Valid | Valid | Ignored | Ignored |
| Extended Frame | Valid | Valid | Valid | Valid | Valid |

In the AFMR mask register, enable (unmask) the compare functions for each field for the incoming Rx CAN message by writing a 1 to the bit field. In the AFIR register, write the values that are to be compared to the in-coming Tx CAN message.

Example: Program the AFMR and AFIR for Standard Frames

This example sets up the acceptance filter for standard frames. The frame ID number is shown to be 0x5DEF, but could be set to desired value for the application.

1. **Configure filter mask for standard frames.** Write 0xFFF8_0000 to the can.AFMR register:
 - a. Enable the compare for the standard message ID, [AMIDE] = 1.
 - b. Compare all bits in the standard message ID, [AMIDH] = 0x7FF.
 - c. Enable the compare for substitute remote transmission request, [AMSRR] = 1.
 - d. Zero-out the extended frame bits, [AMIDL, AMRTR] = 0.
2. **Configure filter ID for standard frames.** Write 0xABC0_0000 to the can.AFIR register:
 - a. Select the standard frame message mode, [AIIDE] = 0.
 - b. Program the standard message ID, [AIIDH] = 0x55E.
 - c. Disable substitute remote transmission request, [AISRR] = 0.
 - d. Zero-out extended frame bits, [AIIDL, AIRTR] = 0.

Example: Program the AFMR and AFIR for Extended Frames

This example setups up the acceptance filter for extended frames. The Frame ID number is shown to be 0x5DF, but could be set to desired value for the application.

1. **Configure filter mask for extended frames.** Write 0xFFFF_FFFF to the can.AFMR register:
 - a. Enable the substitute remote transmission request mask for frame, [AMSRR] = 1.
 - b. Compare all bits in the compare for the standard message ID, [AMIDH] = 0x7FF.
 - c. Enable the extended frame, [AMIDE] = 1.
 - d. Extended ID, [AMIDL] = 0x3FFFF
 - e. Remote transmission request bit for extended frame, [AMRTR] = 1.
2. **Configure filter ID for extended frames.** Write 0xABDF_9BDE to the can.AFIR register:
 - a. Standard ID, [AIIDH] = 0x55E.
 - b. Remote transmission request bit for standard frame, [AISRR] = 1.
 - c. Select standard/extended frame, [AIIDE] = 1.
 - d. Extended ID, [AIIDL] = 3CDEF.
 - e. Remote transmission request bit for extended frame, [AIRTR] = 0

18.2.6 Protocol Engine

The CAN protocol engine consists primarily of the bit timing logic (BTL) and the bitstream processor (BSP) modules. Figure 18-5 shows a block diagram of the CAN protocol engine.

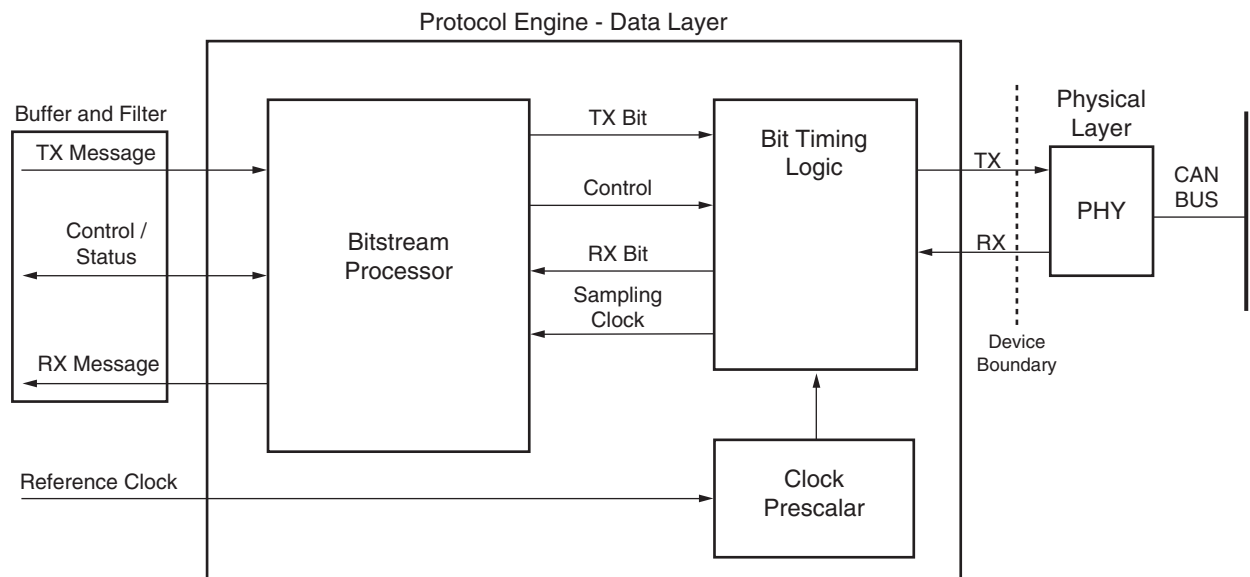

UG585_c18_03_101012

Figure 18-5: CAN Protocol Engine

Rx/Tx Bit Timing Logic

The primary functions of the bit timing logic (BTL) module include:

- Generate the Rx sampling clock for the bitstream processor (BSP)
- Synchronize the CAN controller to CAN traffic on the bus
- Sample the bus and extracting the data stream from the bus during reception
- Insert the transmit bit stream onto the bus during transmission

The nominal length of the bit time clock period is based on the CAN_REF_CLK clock frequency, the baud rate generator divider (can.BRPR register) and the segment lengths (can.BTR register).

The bit timing logic module manages the re-synchronization function for CAN using the sync width parameter in the can.BTR[SJW] bit field. The CAN bit timing is shown in Figure 18-6.

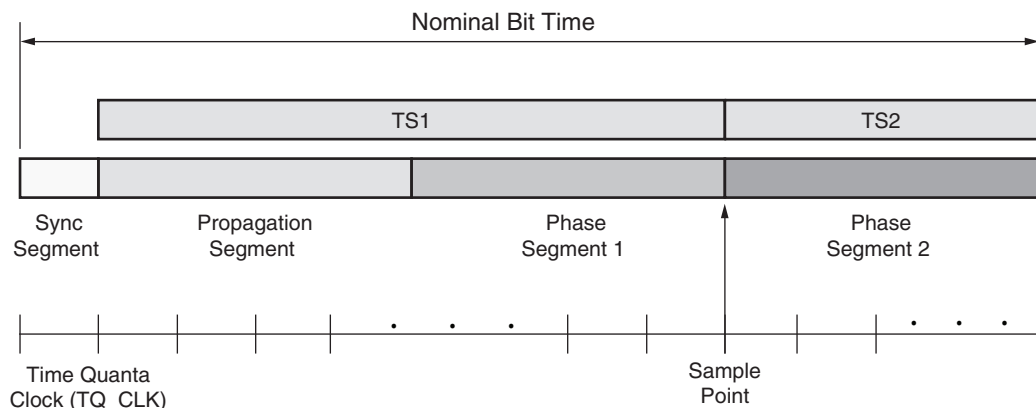

UG585_c18_04_073012

Figure 18-6: CAN Bit Time

Sync Segment count always equals one time quanta period.

The TS 1 and TS 2 period counts are programmable using the can.BTR[TS1, TS2] bit fields. These registers are written when the controller is in Configuration mode. The width of the propagation segment (PROP_SEG) must be less than the actual propagation delay.

Time Quanta Clock

The time quanta clock (TQ_CLK) is derived from the controller reference clock (CAN_REF_CLK) divided by the baud rate prescaler (BRP).

$$tTQ_CLK = tCAN_REF_CLK * (can.BRPR[BRP] + 1)$$

$$freqTQ_CLK = freqCAN_REF_CLK / (can.BRPR[BRP] + 1)$$

$$tSYNC_SEGMENT = 1 * tTQ_CLK$$

$$tTIME_SEGMENT1 = tTQ_CLK * (can.BTR[TS1] + 1)$$

$$tTIME_SEGMENT2 = tTQ_CLK * (can.BTR[TS2] + 1)$$

$$t_{\text{BIT_RATE}} = t_{\text{SYNC_SEGMENT}} + t_{\text{TIME_SEGMENT1}} + t_{\text{TIME_SEGMENT2}}$$

$$\text{freq}_{\text{BIT_RATE}} = \text{freq}_{\text{CAN_REF_CLK}} / ((\text{can.BRPR}[\text{BRP}] + 1) * (3 + \text{can.BTR}[\text{TS1}] + \text{can.BTR}[\text{TS2}])))$$



TIP: A given bit-rate can be achieved with several bit-time configurations, but values should be selected after careful consideration of oscillator tolerances and CAN propagation delays. For more information on CAN bit-time register settings, refer to the CAN 2.0A, CAN 2.0B, and ISO 11898-1 specifications.

Bitstream Processor

The bitstream processor (BSP) module performs several functions while sending and receiving CAN messages. The BSP obtains a message for transmission from either the TxFIFO or the TxHPB and performs the following functions before passing the bitstream to the BTL.

- Serializing the message
- Inserting stuff bits, CRC bits, and other protocol defined fields during transmission

During transmission the BSP simultaneously monitors Rx data and performs bus arbitration tasks. It then transmits the complete frame when arbitration is won, and retrying when arbitration is lost.

During reception the BSP removes stuff bits, CRC bits, and other protocol fields from the received bitstream. The BSP state machine also analyses bus traffic during transmission and reception for Form, CRC, ACK, Stuff, and Bit violations. The state machine then performs error signaling and error confinement tasks. The CAN controller does not voluntarily generate overload frames but does respond to overload flags detected on the bus.

This module determines the error state of the CAN controller: error active, error passive or bus-off. When Tx or Rx errors are observed on the bus, the BSP updates the transmit and receive error counters according to the rules defined in the CAN 2.0 A, CAN 2.0 B and ISO 11898-1 standards. Based on the values of these counters, the error state of the CAN controller is updated by the BSP.

18.2.7 CAN0-to-CAN1 Connection

The I/O signals of the two CAN controllers in the PS can be connected together. In this mode, the RX signal of one CAN controller is connected to the TX signal of the other controller. These connections are enabled using the slcr.MIO_LOOPBACK [CAN0_LOOP_CAN1] bit.

Limitation

The CAN controller registers require single 32-bit read/write accesses, do not use byte, halfword, or double word references.

18.3 Programming Guide

18.3.1 Overview

The controller has several operating modes and different ways to receive and transmit messages. The low-level functions were described in [18.2 Functional Description](#). The system-level operations are described in section [18.4 System Functions](#).

All the controller registers are listed in [Table 18-6](#) and are described in detail in [Appendix B, Register Details](#).

18.3.2 Configuration Mode State

The CAN controller enters configuration mode, irrespective of the operation mode, when any of these actions are performed:

- Writing a 0 to the CEN bit in the SRR register.
- Writing a 1 to the SRST bit in the SRR register. The controller enters Configuration mode immediately following the software reset.
- Driving a 1 on the Reset input controlled via SLCR. The controller continues to be in reset as long as Reset is 1. The controller enters configuration mode after Reset is negated to 0.

In configuration mode the following apply:

- The CAN controller loses synchronization with the CAN bus and drives a constant recessive bit on the bus line.
- The Error Count register (ECR) is reset.
- The Error Status register (ESR) is reset.
- The Bit Timing register (BTR) and Baud Rate Prescaler register (BRPR) can be modified.
- The CAN controller does not receive any new messages.
- The CAN controller does not transmit any messages. Messages in the TxFIFO and the TxHPB are appended. These packets are sent when normal operation is resumed.
- Reads from the RxFIFO can be performed.
- Writes to the TxFIFO and TxHPB can be performed (provided the SNOOP bit is not set).
- Interrupt Status register bits ARBLST, TXOK, RXOK, RXOFLW, ERROR, BSOFF, SLP, and WKUP are cleared.
- Interrupt Status register bits RXNEMP and RXUFLW can be set due to read operations to the RxFIFO.
- Interrupt Status register bits TXBFLL and TXFLL, and Status register bits TXBFLL and TXFLL can be set due to write operations to the TX HPB and TX FIFO, respectively.
- Interrupts are generated if the corresponding bits in the Interrupt Enable register (IER) are 1.
- All Configuration registers are accessible.

When in configuration mode, the CAN controller stays in this mode until the CEN bit in the SRR register is set to 1. After the CEN bit is set to 1 the CAN controller waits for a sequence of 11 recessive bits before exiting configuration mode.

The CAN controller enters normal, loop back, snoop, or sleep modes from configuration mode, depending on the LBACK, SNOOP, and SLEEP bits in the MSR register.

18.3.3 Start-up Controller

The controller can operate in Normal, Sleep, Snoop and Loop Back modes. Refer to [Figure 18-3](#) for supported transitions. On start-up the controller clocks and configuration bits are programmed. Then the operating mode is selected and enabled.

Example: Start-up Sequence

1. **Configure clocks.** Refer to section [18.4.1 Clocks](#).
2. **Configure Tx/Rx signals.** Refer to section [18.5.1 MIO Programming](#).
3. Wait for configuration mode. Read can.SR[CONFIG] until it equals 1.
4. **Reset the controller.** The controller comes up in Configuration mode. Refer to section [18.4.2 Resets](#).
5. **Program the bit sampling clock.** Refer to section [Rx/Tx Bit Timing Logic](#).
6. **Program the interrupts, as needed.** Refer to section [18.2.4 Interrupts](#).
7. **Program the acceptance filters.** Refer to section [18.2.5 Rx Message Filtering](#).
8. **Select operating mode.** Normal, Sleep, Snoop or LoopBack. Refer to section [18.3.4 Change Operating Mode](#).
9. **Enable the controller.** Write a 1 to can.SRR[CEN].

18.3.4 Change Operating Mode

Example: Normal to Sleep Mode

Sleep mode is entered from Normal Mode when the following conditions are met:

1. **Select Sleep Mode.** Write 1 to can.MSR[SLEEP].
2. **Wait for CAN bus to go idle.**
3. **Wait for all TxFIFO and TxHPB messages to be transmitted.**

Note: In normal mode, can.MSR[LBACK] = 0 and can.SSR[CEN] = 1. Also, can.MSR[SNOOP] = don't care.

Example: Configuration to Sleep Mode

Sleep mode is entered from Configuration Mode when the following conditions are met:

1. **Select Sleep Mode.** Write 1 to can.MSR[SLEEP] and write 0 to can.MSR[LBACK].

2. **Enable the controller.** Write 1 to can.SSR[CEN].
3. **Wait for TxFIFO or TxHPB to empty.**

Note: In configuration mode, can.MSR[SNOOP] = don't care.

Sleep mode is exited when I/O bus activity is detected or when software writes a message to either the TxFIFO or the TxHPB. When the controller exits sleep mode, can.MSR[SLEEP] is set to 0 by the hardware and an interrupt can be generated.

18.3.5 Write Messages to TxFIFO

With either option, can.SR[TXFLL] can be polled before writing a message.

All messages written to the TxFIFO should follow the format defined in Message Structure.

Example: Write Message to TxFIFO Using Polling Method

1. **Poll the TxFIFO status.** Read can.SR[TXFLL] for 0 and can.SR[TXFEMP] for 1 and then message can be written into the TxFIFO.
2. **Write message to TxFIFO.** Write to all four data registers (can.TXFIFO_ID, can.TXFIFO_DLC, can.TXFIFO_DATA1, and can.TXFIFO_DATA2).

Example: Write Message to TxFIFO Using Interrupt Method

In interrupt mode, writes can continue until can.ISR[TXFLL] generates an interrupt.

Messages can be continuously written to the TxFIFO until the TxFIFO is full. When the TxFIFO is full the can.ISR[TXFLL] and can.SR[TXFLL] are set to 1. When the TxFIFO is empty, can.ISR[TXFEMP] is set to 1.

18.3.6 Write Messages to TxHPB

All messages written to the TxHPB use the polling method. The format should follow section [18.2.2 Message Format](#).

Example: Write Message to TxHPB

1. **Poll the TxHPB status.** Read can.SR[TXBFLL] until it equals 0 and then write the message into the TxHPB.
2. **Write message to TxHPB.** Write to all four data registers (can.TXHPB_ID, can.TXHPB_DLC, can.TXHPB_DATA1, and can.TXHPB_DATA2).

18.3.7 Read Messages from RxFIFO

Whenever a new message is received and put into the RxFIFO, the can.ISR[RXNEMP] and can.ISR[RXOK] bits are set to 1. If the RxFIFO is empty when the message is read, then the can.ISR[RXUFLW] is also set to 1.

Example: Read Message from RxFIFO Using Polling Method

1. **Poll the RxFIFO status.** Read can.ISR[RXOK] or can.ISR[RXNEMP] register until a message is received. Proceed to step 2 when a bit is set.
2. **Read message from the RxFIFO.** Read all four of the registers (can.RXFIFO_ID, can.RXFIFO_DLC, can.RXFIFO_DATA1, can.RXFIFO_DATA2).
3. **Determine if more messages are in the RxFIFO.** Read can.ISR[RXNEMP].

Example: Read Message from RxFIFO Using Interrupt Method

The can.ISR[RXOK] and/or can.ISR[RXNEMP] bit fields can generate the interrupt.

1. **Program RxFIFO watermark level interrupt.** Write to can.WIR[FW] to set watermark can.ISR[RXFWMFLL] interrupt.
2. **Proceed to step 3 when an interrupt is received.**
3. **Wait until a message is received.** Read can.ISR[RXOK] or can.ISR[RXFWMFLL].
4. **Read message from the RxFIFO.** Read all four of the registers (can.RXFIFO_ID, can.RXFIFO_DLC, can.RXFIFO_DATA1, can.RXFIFO_DATA2).
5. **Determine if RxFIFO is not empty.** Read can.ISR[RXNEMP].
6. **Repeat until the RxFIFO is empty.**
7. **Clear the interrupt.**

18.3.8 Register Overview

The control and status registers are listed in see Table 18-6. Each of these registers is 32-bits wide. Any read operations to reserved bits or bits that are not used return 0. A 0 should be written to reserved bits and bit fields not used. Writes to reserved locations are ignored.

Table 18-6: CAN Register Overview

| Function | Register Names (CAN registers, except where noted) | Overview |
|---------------------------|---|---|
| Configuration and Control | SRR MSR BRPR BTR ECR TCR | Enable/disable and reset the controller. Setup baud rate and timing. Clear timestamp counter. |
| Interrupt Processing | ISR IER ICR WIR | Enable/disable the interrupt detection, mark interrupt sent to the interrupt controller, read raw interrupt status. |
| Status | ECR ESR SR | Inform about the status of the controller. |

Table 18-6: CAN Register Overview (Cont'd)

| Function | Register Names (CAN registers, except where noted) | Overview |
|-------------------------------|--|--|
| Transmit FIFO | TXFIFO_ID TXFIFO_DLC TXFIFO_DATA1 TXFIFO_DATA2 | Write message to be transmitted. |
| Transmit High Priority Buffer | TXHPB_ID TXHPB_DLC TXHPB_DATA1 TXHPB_DATA2 | Store one high priority transmit message. |
| Receive FIFO | RXFIFO_ID RXFIFO_DLC RXFIFO_DATA1 RXFIFO_DATA2 | Read received message. |
| Acceptance Filter | AFR AFMR[4:1] AFIR[4:1] | Configure and control the four acceptance filters. |
| System level | slcr.CAN_CLK_CTRL slcr.CAN_MIOCLK_CTRL slcr.CAN_RST_CTRL | A controller reset and clock control. |

18.4 System Functions

18.4.1 Clocks

The controller and I/O interface are driven by the reference clock (CANx_REF_CLK). The controller's interconnect also requires an APB interface clock. The APB interconnect clock (CPU_1x) always comes from the PS clock subsystem.

The reference clock normally comes from the PS clock subsystem, but it can alternatively be driven by an external clock source via any available MIO pin. The reference clock is used by the protocol engine, the baud rate generator, and the datapath. The controllers share the same reference clock frequency from the PS clock subsystem. If the reference clock is from an MIO pin, then the frequencies can be different.

CPU_1x Clock

Refer to [Chapter 25, Clocks](#), for general clock programming information. The CPU_1x clock runs asynchronous to the CAN reference clock.

Reference Clock

CAN_REF_CLK is normally sourced from the PS clock subsystem, but it can alternatively be driven by an external clock source via an MIO pin. Internally, the PS has three PLLs and two clock divider pairs. The clock source choice, PS clock subsystem or external MIO pin, is controlled by the CAN_MIOCLK_CTRL register.

The CAN clocks in the PS are controlled by slcr.CAN_CLK_CTRL. The generation of the CAN reference clock by the PS is described in section [The Quad-SPI clock is divided down by at least two using the Quad-SPI baud rate divider, see section 12.4.1 Clocks](#). In master mode, the SPI clock is divided down by at least four using the SPI baud rate divider, see section [17.4.2 Clocks](#). There is one clock generator in the PS for both CAN controllers. If an MIO pin is used instead, the selected MIO_PIN Mux register is programmed as an input.

Example: Configure and Route Internal Clock for Reference Clock

Configure the clock and disable MIO path. Assume the PLL is operating at 1000 MHz and the required CAN reference clock is 24 MHz (23.8095 MHz).

1. **Program the clock subsystem.** Write `0x0030_0E03` to the slcr.CAN_CLK_CTRL register:
 - a. Enable both CAN reference clocks.
 - b. Divide the I/O PLL clock by 42 (`0x02A`): `DIVISOR0= 0x0E` and `DIVISOR1=0x03` used by both controllers.
2. **Disable the MIO path.** Write `0x0000_0000` to the slcr.CAN_MIOCLK_CTRL register to select the clock from the internal clock subsystem/PLL for both controllers.

Example: Source Controller Clock from MIO Pin

This example uses MIO pin 45 as a controller clock reference.

1. **Configure MIO device pin.** Write `0x0000_1200` to the slcr.MIO_PIN_45 register:
 - a. Route MIO pin 45 to the GPIO controller (this is overridden in the next step).
 - b. Disable the output driver (`TRI_ENABLE = 1`).
 - c. LVCMOS18 (refer to the register definition for other voltage options).
 - d. Slow CMOS edge (benign setting).
 - e. Enable internal pull-up resistor.
 - f. Disable HSTL receiver.
2. **Enable MIO path.** Write to the slcr.CAN_MIOCLK_CTRL register to override the MIO PIN register setting that was written in the previous step.

Write a 1 to slcr.CAN_MIOCLK_CTRL[CANx__REF_SEL] and write the desired MIO pin number into the slcr.CAN_MIOCLK_CTRL[CANx_MUX] bit field to match the pin in the previous step.

18.4.2 Resets

The effects for each reset type are summarized in [Table 18-7](#).

Table 18-7: CAN Reset Effects

| Name | APB Interface | Rx and Tx FIFOs | Protocol Engine | Control and Status Registers | Acceptance Filters (ID and Mask) |
|--|---------------|-----------------|-----------------|------------------------------|----------------------------------|
| Local CAN Reset can.SRR[SRST] | Yes | Yes | Yes | Yes | No |
| PS Reset Subsystem slcr.CAN_RST_CTRL[CANx_CPU1X_RST] | Yes | Yes | Yes | Yes | No |

Example: Reset using Local CAN Reset

1. **Write to the Local CAN reset register.** Write a 1 to can.SRR[SRST] bit field. This bit is self-clearing.

Example: Reset using Reset Subsystem

1. **Write to the slcr reset register for CAN.** Write a 1 then a 0 to the slcr.CAN_RST_CTRL[CANx_CPU1X_RST] bit field.

18.5 I/O Interface

18.5.1 MIO Programming

Each set of controller Rx/Tx signals is connected to either MIO pins or the EMIO interface, refer to [Table 18-8, page 579](#). The general routing concepts and MIO I/O buffer configurations are explained in section [2.4 PS-PL Voltage Level Shifter Enables](#). The MIO routing to use an external reference clock (CAN_REF_CLK) is described in section [18.4.1 Clocks](#).

Example: Configure Rx/Tx Signals to MIO Pins

1. **Configure MIO pin 46 for the Rx signal.** Write 0x0000_1221 to the slcr.MIO_PIN_46 register:
 - a. Route CAN0 Rx signal to pin 46.
 - b. Output disabled (set TRI_ENABLE = 1).
 - c. LVCMOS18 (refer to the register definition for other voltage options).
 - d. Slow CMOS edge (benign setting).
 - e. Enable internal pull-up resistor.
 - f. Diable HSTL receiver.
2. **Configure MIO pin 47 for the Tx signal.** Write 0x0000_1220 to the slcr.MIO_PIN_47 register:
 - a. Route CAN0 Tx signal to pin 47.
 - b. 3-state controlled by CAN (TRI_ENABLE = 0).
 - c. LVCMOS18 (refer to the register definition for other voltage options).
 - d. Slow CMOS drive edge.

- e. Enable internal pull-up resistor.
- f. Disable HSTL receiver.

18.5.2 MIO-EMIO Signals

The CAN I/O Signals are identified in [Table 18-8](#). Refer to section [2.4 PS-PL Voltage Level Shifter Enables](#) for routing details. The MIO pins and any restrictions based on device versions are shown in the MIO table in section [2.5.4 MIO-at-a-Glance Table](#).

Table 18-8: CAN MIO Pins and EMIO Signals

| CAN Interface | Default Controller Input Value | MIO Pins | | EMIO Signals | |
|---------------|--------------------------------|---|-----|---------------|-----|
| | | Numbers | I/O | Name | I/O |
| CAN 0 Rx | 0 | 10, 14, 18, 22, 26, 30, 34, 38, 42, 46, 50 | I | EMIOCAN0PHYRX | I |
| CAN 0 Tx | ~ | 11, 15, 19, 23, 27, 31, 35, 39, 43, 47, 51 | O | EMIOCAN0PHYTX | O |
| CAN 0 CLK | ~ | Any MIO pin | I | ~ | ~ |
| CAN 1 Rx | 0 | 9, 13, 17, 21, 25, 29, 33, 37, 41, 45, 49, 53 | I | EMIOCAN1PHYRX | I |
| CAN 1 Tx | ~ | 8, 12, 16, 20, 24, 28, 32, 36, 40, 44, 48, 52 | O | EMIOCAN1PHYTX | O |
| CAN 1 CLK | ~ | Any MIO pin | I | ~ | ~ |

UART Controller

19.1 Introduction

The UART controller is a full-duplex asynchronous receiver and transmitter that supports a wide range of programmable baud rates and I/O signal formats. The controller can accommodate automatic parity generation and multi-master detection mode.

The UART operations are controlled by the configuration and mode registers. The state of the FIFOs, modem signals and other controller functions are read using the status, interrupt status and modem status registers.

The controller is structured with separate Rx and Tx data paths. Each path includes a 64-byte FIFO. The controller serializes and de-serializes data in the Tx and Rx FIFOs and includes a mode switch to support various loopback configurations for the Rx and Tx signals. The FIFO interrupt status bits support a polling or interrupt driven handler. Software reads and writes data bytes using the Rx and Tx data port registers.

When the UART is being used in a modem-like application, the modem control module detects and generates the modem handshake signals and also controls the receiver and transmitter paths according to the handshaking protocol.

19.1.1 Features

Each UART controller (UART 0 and UART 1) has the following features:

- Programmable baud rate generator
- 64-byte receive and transmit FIFOs
- Programmable protocol:
 - 6, 7, or 8 data bits
 - 1, 1.5, or 2 stop bits
 - Odd, even, space, mark, or no parity
- Parity, framing and overrun error detection
- Line-break generation
- Interrupts generation
- Rx and Tx modes: Normal/echo and diagnostic loopbacks using the mode switch

- Loop UART 0 with UART 1 option
- Modem control signals: CTS, RTS, DSR, DTR, RI and DCD are available only on the EMIO interface

19.1.2 System Viewpoint

The system viewpoint diagram for the UART controllers is shown in [Figure 19-1](#).

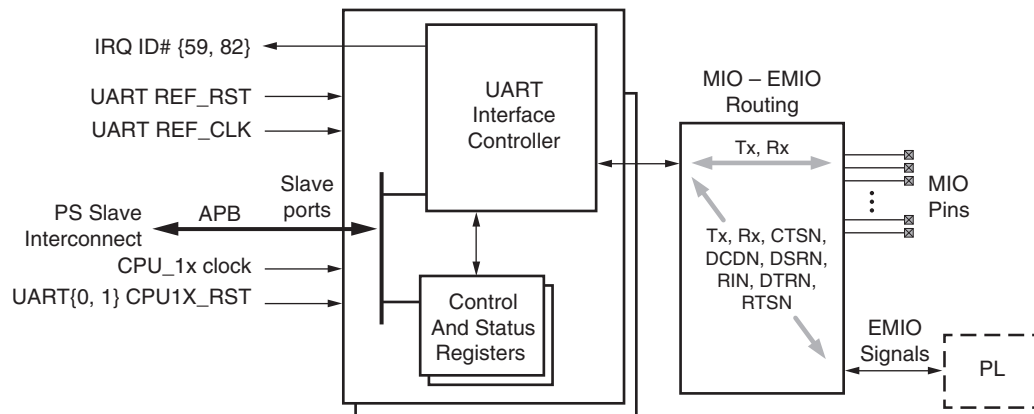

UG585_c19_01_010112

Figure 19-1: UART System Viewpoint

The slcr register set (refer to section [4.3 SLCR Registers](#)) includes control bits for the UART clocks, resets and MIO-EMIO signal mapping. Software accesses the UART controller registers using the APB 32-bit slave interface attached to the PS AXI interconnect. The IRQ from each controller is connected to the PS interrupt controller and routed to the PL.

19.1.3 Notices

Reference Clock Operating Restrictions

There is a single PS clock generator for both UART controllers. The reference clocks (UART_Ref_Clk) going to the baud rate generator of each UART controller are of the same clock frequency, but are individually enabled, refer to section [25.6.3 SDIO, SMC, SPI, Quad-SPI and UART Clocks](#). The controllers are always clocked by the internal, PS clock generator.

Note: There are no frequency restrictions in the relationship between the CPU_1x and UART_Ref_clk clocks.

7z007s and 7z010 CLG225 Devices

The 7z007s single core and 7z010 dual core CLG225 devices support 32 MIO pins as shown in the [MIO-at-a-Glance Table, page 53](#). This restricts the availability of the UART signals on the MIO pins. If needed, the Tx and Rx UART signals can be routed through the EMIO interface and passed-through to the PL pins. All of the CLG225 device restrictions are listed in section [1.1.3 Notices](#).

19.2 Functional Description

19.2.1 Block Diagram

The block diagram for the UART module is shown in [Figure 19-2](#)

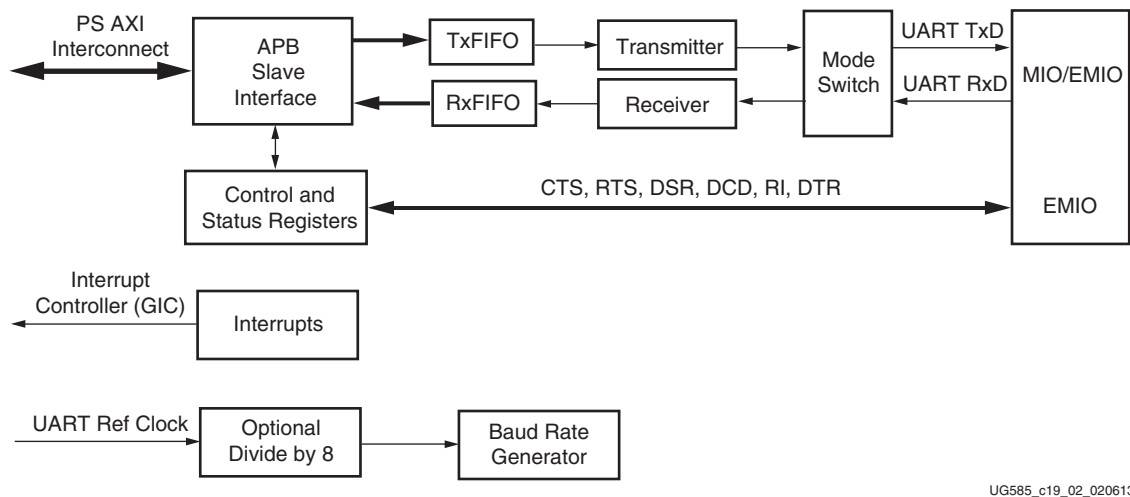

Figure 19-2: UART Block Diagram

19.2.2 Control Logic

The control logic contains the Control register and the Mode register, which are used to select the various operating modes of the UART.

The Control register enables, disables, and issues soft resets to the receiver and transmitter modules. In addition, it restarts the receiver timeout period, and controls the transmitter break logic.

Receive line break detection must be implemented in Software. It will be indicated by a Frame Error followed by one or more zero bytes in the Rx FIFO.

The Mode register selects the clock used by the baud rate generator. It also selects the bit length, parity bit and stop bit to be used by transmitted and received data. In addition, it selects the mode of operation of the UART, switching between normal UART mode, automatic echo, local loopback, or remote loopback, as required.

19.2.3 Baud Rate Generator

The baud rate generator furnishes the bit period clock, or baud rate clock, for both the receiver and the transmitter. The baud rate clock is implemented by distributing the base clock `uart_clk` and a single cycle clock enable to achieve the effect of clocking at the appropriate frequency division. The effective logic for the baud rate generation is shown in [Figure 19-3](#).

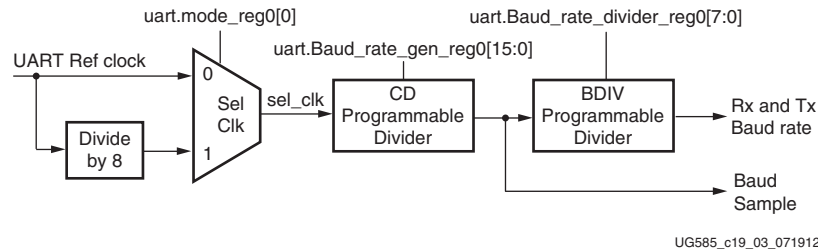

Figure 19-3: UART Board Rate Generator

The baud rate generator can use either the master clock signal, `uart_ref_clk`, or the master clock divided by eight, `uart_ref_clk/8`. The clock signal used is selected according to the value of the `CLKS` bit in the Mode register (`uart.mode_reg0`). The resulting selected clock is termed `sel_clk` in the following description.

The `sel_clk` clock is divided down to generate three other clocks: `baud_sample`, `baud_tx_rate`, and `baud_rx_rate`. The `baud_tx_rate` is the target baud rate used for transmitting data. The `baud_rx_rate` is nominally at the same rate, but gets resynchronised to the incoming received data. The `baud_sample` runs at a multiple (`[BDIV] + 1`) of `baud_rx_rate` and `baud_tx_rate` and is used to over-sample the received data.

The `sel_clk` clock frequency is divided by the `CD` field value in the Baud Rate Generator register to generate the `baud_sample` clock enable. This register can be programmed with a value between 1 and 65535.

The `baud_sample` clock is divided by `[BDIV] + 1`. `BDIV` is a programmable field in the Baud Rate Divider register and can be programmed with a value between 4 and 255. It has a reset value of 15, inferring a default ratio of 16 `baud_sample` clocks per `baud_tx_rate` / `baud_rx_rate`.

Thus the frequency of the `baud_sample` clock enable is shown in Equation 19-1.

$$baud_sample = \frac{sel_clk}{CD} \tag{Equation 19-1}$$

The frequency of the `baud_rx_rate` and `baud_tx_rate` clock enables is show in Equation 19-2.

$$baud_rate = \frac{sel_clk}{CD \times (BDIV + 1)} \tag{Equation 19-2}$$



IMPORTANT: It is essential to disable the transmitter and receiver before writing to the Baud Rate Generator register (`uart.Baud_rate_gen_reg0`), or the baud rate divider register (`uart.Baud_rate_divider_reg0`). A soft reset must be issued to both the transmitter and receiver before they are re-enabled.

Some examples of the relationship between the `uart_ref_clk` clock, baud rate, clock divisors (`CD` and `BDIV`), and the rate of error are shown in Table 19-1. The highlighted entry shows the default reset

values for CD and BDIV. For these examples, a system clock rate of UART_Ref_Clk = 50 MHz and Uart_ref_clk/8 = 6.25 MHz is assumed. The frequency of the UART reference clock can be changed to get a more accurate Baud rate frequency, refer to [Chapter 25, Clocks](#) for details to program the UART_Ref_Clk.

Table 19-1: UART Parameter Value Examples

| Clock | Baud Rate | Calculated CD | Actual CD | BDIV | Actual Baud Rate | Error (BPS) | % Error |
|-------------------|-----------|---------------|-----------|------|------------------|-------------|---------|
| UART Ref clock | 600 | 10416.667 | 10417 | 7 | 599.980 | 0.020 | -0.003 |
| UART Ref clock /8 | 9,600 | 81.380 | 81 | 7 | 9,645.061 | 45.061 | 0.469 |
| UART Ref clock | 9,600 | 651.041 | 651 | 7 | 9,600.614 | 0.614 | 0.006 |
| UART Ref clock | 28,800 | 347.222 | 347 | 4 | 28,818.44 | 18.44 | 0.064 |
| UART Ref clock | 115,200 | 62.004 | 62 | 6 | 115,207.37 | 7.373 | 0.0064 |
| UART Ref clock | 230,400 | 31.002 | 31 | 6 | 230,414.75 | 14.75 | 0.006 |
| UART Ref clock | 460,800 | 27.127 | 9 | 11 | 462,962.96 | 2,162.96 | 0.469 |
| UART Ref clock | 921,600 | 9.042 | 9 | 5 | 925,925.92 | 4,325.93 | 0.469 |

19.2.4 Transmit FIFO

The transmit FIFO (TxFIFO) stores data written from the APB interface until it is removed by the transmit module and loaded into its shift register. The TxFIFO’s maximum data width is eight bits. Data is loaded into the TxFIFO by writing to the TxFIFO register.

When data is loaded into the TxFIFO, the TxFIFO empty flag is cleared and remains in this Low state until the last word in the TxFIFO has been removed and loaded into the transmitter shift register. This means that host software has another full serial word time until the next data is needed, allowing it to react to the empty flag being set and write another word in the TxFIFO without loss in transmission time.

The TxFIFO full interrupt status (TFULL) indicates that the TxFIFO is completely full and prevents any further data from being loaded into the TxFIFO. If another APB write to the TxFIFO is performed, an overflow is triggered and the write data is not loaded into the TxFIFO. The transmit FIFO nearly full flag (TNFULL) indicates that there is not enough free space in the FIFO for one more write of the programmed size, as controlled by the WSIZE bits of the Mode register.

The TxFIFO nearly-full flag (TNFULL) indicates that there is only byte free in the TxFIFO.

A threshold trigger (TTRIG) can be setup on the TxFIFO fill level. The Transmitter Trigger register can be used to setup this value, such that the trigger is set when the TxFIFO fill level reaches this programmed value.

19.2.5 Transmitter Data Stream

The transmit module removes parallel data from the TxFIFO and loads it into the transmitter shift register so that it can be serialized.

The transmit module shifts out the start bit, data bits, parity bit, and stop bits as a serial data stream. Data is transmitted, least significant bit first, on the falling edge of the transmit baud clock enable (baud_tx_rate). A typical transmitted data stream is illustrated in Figure 19-4.

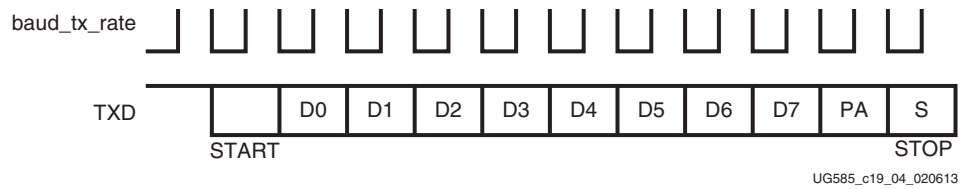

Figure 19-4: Transmitted Data Stream

The `uart.mode_reg0[CHRL]` register bit selects the character length, in terms of the number of data bits. The `uart.mode_reg0[NBSTOP]` register bit selects the number of stop bits to transmit.

19.2.6 Receiver FIFO

The Rx FIFO stores data that is received by the receiver serial shift register. The Rx FIFO's maximum data width is eight bits.

When data is loaded into the Rx FIFO, the Rx FIFO empty flag is cleared and this state remains Low until all data in the Rx FIFO has been transferred through the APB interface. Reading from an empty Rx FIFO returns zero.

The Rx FIFO full status (`Chnl_int_sts_reg0 [RFUL]` and `Channel_sts_reg0 [RFUL]` bits) indicates that the Rx FIFO is full and prevents any further data from being loaded into the Rx FIFO. When a space becomes available in the Rx FIFO, any character stored in the receiver will be loaded.

A threshold trigger (RTRIG) can be setup on the Rx FIFO fill level. The Receiver Trigger Level register (`Rcvr_FIFO_trigger_level0`) can be used to setup this value, such that the trigger is set when the Rx FIFO fill level transitions this programmed value. The Range is 1 to 63.

19.2.7 Receiver Data Capture

The UART continuously over-samples the `UARTx_RxD` signal using `UARTx REF_CLK` and the clock enable (`baud_sample`). When the samples detect a transition to a Low level, it can indicate the beginning of a start bit. When the UART senses a Low level at the `UART_RxD` input, it waits for a count of half of `BDIV` baud rate clock cycles, and then samples three more times. If all three bits still indicate a Low level, the receiver considers this to be a valid start bit, as illustrated in Figure 19-5 for the default `BDIV` of 15.

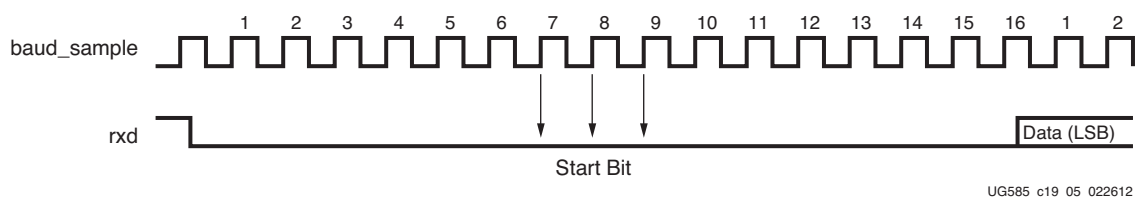

Figure 19-5: Default BDIV Receiver Data Stream

When a valid start bit is identified, the receiver baud rate clock enable (`baud_rx_rate`) is re-synchronised so that further sampling of the incoming UART RxD signal occurs around the theoretical mid-point of each bit, as illustrated in [Figure 19-6](#).

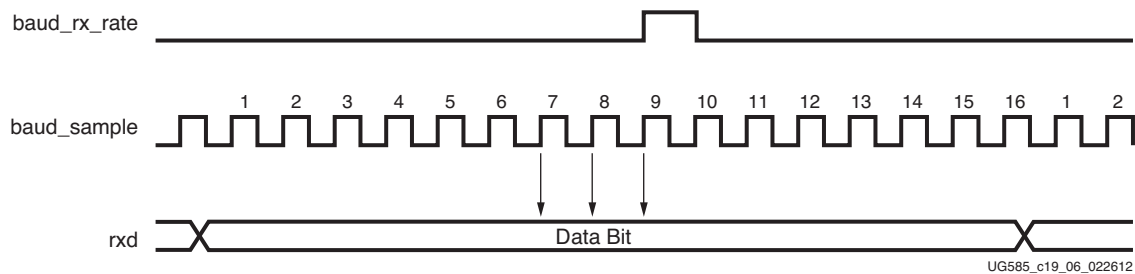

Figure 19-6: Re-synchronized Receiver Data Stream

When the re-synchronised `baud_rx_rate` is High, the last three sampled bits are compared. The logic value is determined by majority voting; two samples having the same value define the value of the data bit. When the value of a serial data bit has been determined, it is shifted to the receive shift register. When a complete character has been assembled, the contents of the register are then pushed to the RxFIFO.

Receiver Parity Error

Each time a character is received, the receiver calculates the parity of the received data bits in accordance with the `uart.mode_reg0 [PAR]` bit field. It then compares the result with the received parity bit. If a difference is detected, the parity error bit is set = 1, `uart.Chnl_int_sts_reg0 [PARE]`. An interrupt is generated, if enabled.

Receiver Framing Error

When the receiver fails to receive a valid stop bit at the end of a frame, the frame error bit is set = 1, `uart.Chnl_int_sts_reg0 [FRAME]`. An interrupt is generated, if enabled.

Receiver Overflow Error

When a character is received, the controller checks to see if the RxFIFO has room. If it does, then the character is written into the RxFIFO. If the RxFIFO is full, then the controller waits. If a subsequent start bit on RxD is detected and the RxFIFO is still full, then data is lost and the controller sets the Rx overflow interrupt bit, `uart.Chnl_int_sts_reg0 [ROVR]` = 1. An interrupt is generated, if enabled.

Receiver Timeout Mechanism

The receiver timeout mechanism enables the receiver to detect an inactive RxD signal (a persistent High level). The timeout period is programmed by writing to the `uart.Rcvr_timeout_reg0 [RTO]` bit field. The timeout mechanism uses a 10-bit decrementing counter. The counter is reloaded and starts counting down whenever a new start bit is received on the RxD signal, or whenever software writes a 1 to `uart.Control_reg0 [RSTTO]` (regardless of the previous [RSTTO] value).

If no start bit or reset timeout occurs for 1,023 bit periods, a timeout occurs. The Receiver timeout error bit [TIMEOUT] will be set in the interrupt status register, and the [RSTTO] bit in the Control register should be written with a 1 to restart the timeout counter, which loads the newly programmed timeout value.

The upper 8 bits of the counter are reloaded from the value in the [RTO] bit field and the lower 2 bits are initialized to zero. The counter is clocked by the UART bit clock. As an example, if [RTO] = 0xFF, then the timeout period is 1,023 bit clocks (256 x 4 minus 1). If 0 is written into the [RTO] bit, the timeout mechanism is disabled.

When the decrementing counter reaches 0, the receiver timeout occurs and the controller sets the timeout interrupt status bit `uart.Chnl_int_sts_reg0 [TIMEOUT] = 1`. If the interrupt is enabled (`uart.Intrpt_mask_reg0 [TIMEOUT] = 1`), then the IRQ signal to the PS interrupt controller is asserted.

Whenever the timeout interrupt occurs, it is cleared with a write back of 1 to the `Chnl_int_sts_reg0 [TIMEOUT]` bit. Software must set `uart.Control_reg0 [RSTTO] = 1` to generate further receive timeout interrupts.

19.2.8 I/O Mode Switch

The mode switch controls the routing of the RxD and TxD signals within the controller as shown in [Figure 19-7](#). The loopback using the mode switch occurs regardless of the MIO-EMIO routing of the UARTx TxD/RxD I/O signals. There are four operating modes as shown in [Figure 19-7](#). The mode is controlled by the `uart.mode_reg0 [CHMODE]` register bit field: normal, automatic echo, local loopback and remote loopback.

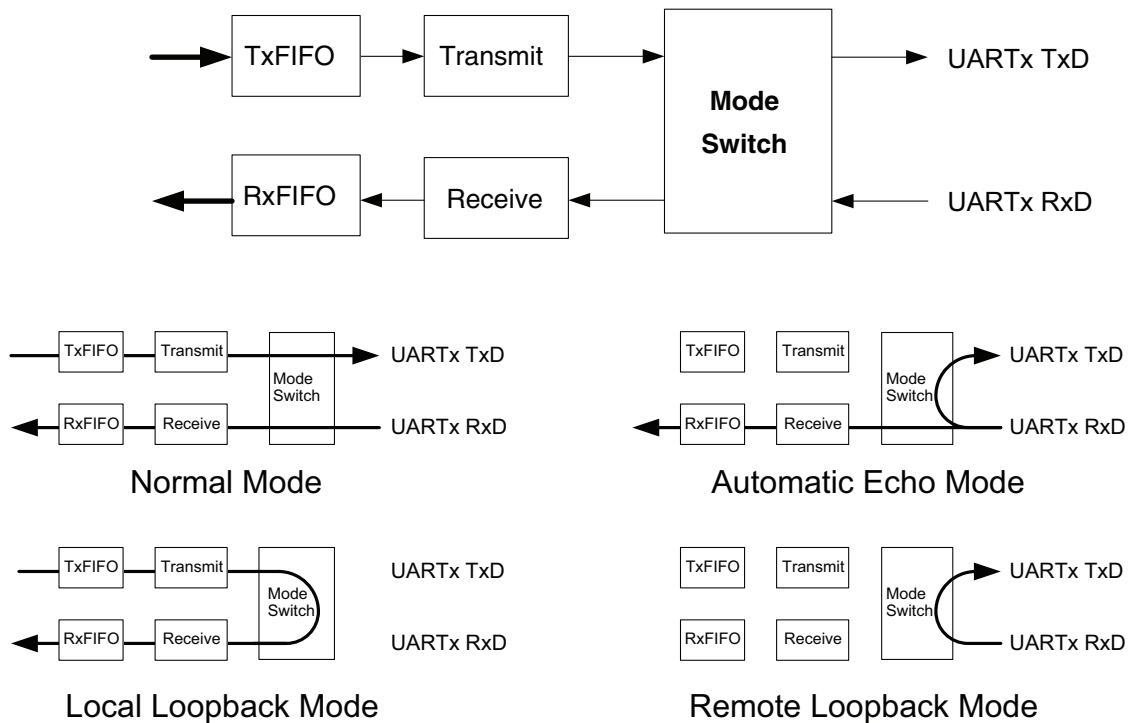

UG585_c19_13_100512

Figure 19-7: UART Mode Switch for TxD and RxD

Normal Mode

Normal mode is used for standard UART operations.

Automatic Echo Mode

Echo mode receives data on RxD and the mode switch routes the data to both the receiver and the TxD pin. Data from the transmitter cannot be sent out from the controller.

Local Loopback Mode

Local loopback mode does not connect to the RxD or TxD pins. Instead, the transmitted data is looped back around to the receiver.

Remote Loopback Mode

Remote loopback mode connects the RxD signal to the TxD signal. In this mode, the controller cannot send anything on TxD and the controller does not receive anything on RxD.

19.2.9 UART0-to-UART1 Connection

The I/O signals of the two UART controllers in the PS can be connected together. In this mode, the RxD and CTS input signals from one controller are connected to the TxD and RTS output signals of the other UART controller by setting the slcr.LOOP [UA0_LOOP_UA1] bit = 1. The other flow control signals are not connected. This UART-to-UART connection occurs regardless of the MIO-EMIO programming.

19.2.10 Status and Interrupts

Interrupt and Status Registers

There are two status registers that can be read by software. Both show raw status. The Chnl_int_sts_reg0 register can be read for status and generate an interrupt. The Channel_sts_reg0 register can only be read for status.

The Chnl_int_sts_reg0 register is sticky; once a bit is set, the bit stays set until software clears it. Write a 1 to clear a bit. This register is bit-wise AND'ed with the Intrpt_mask_reg0 mask register. If any of the bit-wise AND functions have a result = 1, then the UART interrupt is asserted to the PS interrupt controller.

- **Channel_sts_reg0:** Read-only raw status. Writes are ignored.

The various FIFO and system indicators are routed to the uart.Channel_sts_reg0 register and/or the uart.Chnl_int_sts_reg0 register as shown in Figure 19-8.

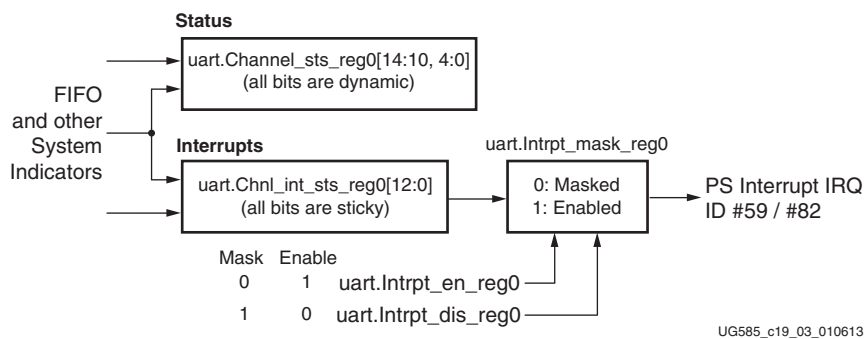

Figure 19-8: Interrupts and Status Signals

The interrupt registers and bit fields are summarized in [Table 19-2](#).

Table 19-2: UART Interrupt Status Bits

| Interrupt Register Names and Bit Assignments | | | | | | | | | | | | | | |
|--|-------|------|---------|---------|------|----------|------|-------|------|------|-------|------|-------|-------|
| 14 | 13 | 12 | 11 | 10 | 9 | 8 | 7 | 6 | 5 | 4 | 3 | 2 | 1 | 0 |
| uart.Intrpt_en_reg0 | | | | | | | | | | | | | | |
| uart.Intrpt_dis_reg0 | | | | | | | | | | | | | | |
| uart.Intrpt_mask_reg0 | | | | | | | | | | | | | | |
| uart.Chnl_int_sts_reg0 | | | | | | | | | | | | | | |
| x | x | TOVR | TNFUL | TTRIG | DMSI | TIME OUT | PARE | FRAME | ROVR | TFUL | EMPTY | RFUL | EMPTY | RTRIG |
| uart.Channel_sts_reg0 | | | | | | | | | | | | | | |
| TNFUL | TTRIG | FDEL | TACTIVE | RACTIVE | X | X | X | X | X | TFUL | EMPTY | RFUL | EMPTY | RTRIG |

Interrupt Mask Register

Intrpt_mask_reg0 is a read-only interrupt mask/enable register that is used to mask individual raw interrupts in the Chnl_int_sts_reg0 register:

- If the mask bit = 0, the interrupt is masked.
- If the mask bit = 1, the interrupt is enabled.

This mask is controlled by the write-only Intrpt_en_reg0 and Intrpt_dis_reg0 registers. Each associated enable/disable interrupt bit should be set mutually exclusive (e.g., to enable an interrupt, write 1 to Intrpt_en_reg0[x] and write 0 to Intrpt_dis_reg0[x]).

Channel Status

These status bits are in the Channel_sts_reg0 register.

- **TACTIVE:** Transmitter state machine active status. If in an active state, the transmitter is currently shifting out a character.
- **RACTIVE:** Receiver state machine active status. If in an active state, the receiver is has detected a start bit and is currently shifting in a character.
- **FDEL:** Receiver flow delay trigger continuous status. The FDEL status bit is used to monitor the Rx FIFO level in comparison with the flow delay trigger level.

Non-FIFO Interrupts

These interrupt status bits are in the Chnl_int_sts_reg0 register.

- **TIMEOUT:** Receiver Timeout Error interrupt status. This event is triggered whenever the receiver timeout counter has expired due to a long idle condition.
- **PARE:** Receiver Parity Error interrupt status. This event is triggered whenever the received parity bit does not match the expected value.
- **FRAME:** Receiver Framing Error interrupt status. This event is triggered whenever the receiver fails to detect a valid stop bit. Refer to section [19.2.7 Receiver Data Capture](#).

- **DMSI**: indicates a change of logic level on the DCD, DSR, RI or CTS modem flow control signals. This includes High-to-Low and Low-to-High logic transitions on any of these signals.

FIFO Interrupts

The status bits for the FIFO interrupts listed in Table 19-2 are illustrated in Figure 19-9. These interrupt status bits are in the Channel Status (uart.Channel_sts_reg0) and Channel Interrupt Status (uart.Chnl_int_sts_reg0) registers with the exception that the [TOVR] and [ROVR] bits are not part of the uart.Channel_sts_reg0 register.

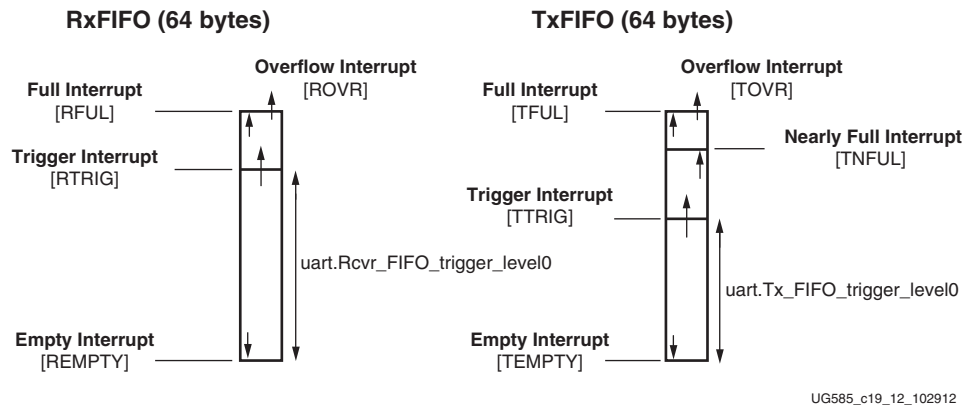

Figure 19-9: UART RxFIFO and TxFIFO Interrupt

The FIFO trigger levels are controlled by these bit fields:

- uart.Rcvr_FIFO_trigger_level0[RTRIG], a 6-bit field
- uart.Tx_FIFO_trigger_level0[TTRIG], a 6-bit field

19.2.11 Modem Control

The modem control module facilitates the control of communication between a modem and the UART. It contains the Modem Status register, the Modem Control register, the DMSI bit in interrupt status register, and FDELTA in the channel status register. This event is triggered whenever the DCTS, DDSR, TERI, or DDCD in the modem status register are being set.

The read-only Modem Status register is used to read the values of the clear to send (CTS), data carrier detect (DCD), data set ready, (DSR) and ring indicator (RI) modem inputs. It also reports changes in any of these inputs and indicates whether automatic flow control mode is currently enabled. The bits in the Modem Status register are cleared by writing a 1 to the particular bit.

The read/write only Modem Control register is used to set the data terminal ready (DTR) and request to send (RTS) outputs, and to enable the Automatic Flow Control Mode register.

By default, the automatic flow control mode is disabled, meaning that the modem inputs and outputs work completely under software control. When the automatic flow control mode is enabled by setting the FCM bit in the Modem Control register, the UART transmission and reception status is automatically controlled using the modem handshake inputs and outputs.

In automatic flow control mode the request to send output is asserted and de-asserted based on the current fill level of the receiver FIFO, which results in the far-end transmitter pausing transmission and preventing an overflow of the UART receiver FIFO. The FDEL field in the Flow Delay register (Flow_delay_reg0) is used to setup a trigger level on the Receiver FIFO which causes the de-assertion of the request to send. It remains Low until the FIFO level has dropped to below four less than FDEL.

Additionally in automatic flow control mode, the UART only transmits while the clear to send input is asserted. When the clear to send is de-asserted, the UART pauses transmission at the next character boundary.

If flow control is selected as automatic, then Flow Delay register must be programmed in order to have a control on the inflow of data, which is done by de-asserting RTS signal. The value corresponds to the Rx FIFO level at which RTS signal will be de-asserted. It will be re-asserted when the Rx FIFO level drops to four below the value programmed in the Flow Delay register.

The `uart.Channel_sts_reg0 [FDELT]` register bit is used to monitor the Rx FIFO level in comparison with the flow delay trigger level. The [FDELT] bit is set whenever the Rx FIFO level is greater than or equal to trigger the level programmed in the Flow Delay register.

The trigger level programmed in the Flow Delay register has no dependency on the Rx Trigger Level register. This is to only control the inflow of data using the RTS modem signal.

The CPU will be interrupted by receive data only on receipt of an Rx Trigger interrupt. Data is retrieved based on the trigger level programmed in the Rx Trigger Level register.

Programmable Parameters

The UART flow control signals, DTR and RTS are generated by the UART controller.

- The RTS flow control signal is used to signal for Rx (ready to send signal to the attached terminal).
- The DTR flow control signal indicates the status of the UART controller (data terminal ready).

The DTR and RTS can be controlled manually by software or automatically by the controller.

- In automatic mode, the modem control unit asserts and de-asserts the RTS and DTR signals.
- In manual mode, software controls the RTS and DTR signals using `uart.Modem_ctrl_reg0`.

uart.Modem_ctrl_reg0:

- [DTR]: Data Terminal Ready output signal
- [RTS]: Request to Send output signal
- [FCM]: Select Automatic or Manual flow control.

uart.Modem_sts_reg0:

- [DCTS]: Delta Clear To Send (input) status
- [DDSR]: Delta Data Set Ready (input) status
- [TERI]: Trailing-edge Ring Indicator (input) status
- [DDCD]: Delta Data Carrier Detect (input) status

Select one of the following operating options:

Example: Automatic Flow Control

1. **Set RTS trigger level.** Write to the `uart.Flow_Delay_reg0` register. This is the trigger level to de-assert modem signal RTS.
2. **Select automatic flow control.** Write a 1 to `uart.Modem_ctrl_reg0` [FCM].
3. **Verify the mode change to automatic.** Read `uart.Modem_sts_reg0` [FCMS] until it equals 1.

When software writes a 1 to `uart.Modem_ctrl_reg0` [FCM], the modem changes to automatic mode. The change of mode from manual to automatic is verified by reading the status bit FCMS in the Modem Status register.

Example: Manual Flow Control

1. **Select manual flow control.** Write a 0 to `uart.Modem_ctrl_reg0` [FCM].
 - Option a. Control the DTR output signal using `uart.Modem_ctrl_reg0` [DTR].
 - Option b. Control the RTS output signal using `uart.Modem_ctrl_reg0` [RTS].

Example: Monitor for a Change in the DCD DSR RI CTS Flow Control Signals

A logic level change to the DCD DSR RI CTS flow control signals is detected by the controller. When a logic level change is detected, the hardware sets the `uart.Chnl_int_sts_reg0` [DMSI] bit. This change, or channel status can optionally generate an interrupt.

1. **Check flow control signal status.** `uart.Modem_sts_reg0` register reports the modem status.

In interrupt mode, the ISR can run when the DMSI interrupt occurs when there is a change of status on modem lines.

Limitation

The UART controller registers require single 32-bit read/write accesses, do not use byte, halfword, or double word references.

19.3 Programming Guide

19.3.1 Start-up Sequence

Main Example: Start-up Sequence

1. **Reset controller:** The reset programming model is described in section [19.4.2 Resets](#).
2. **Configure I/O signal routing:** Rx/Tx can be routed to either MIO or EMIO. The modem control signals are only available on the EMIO interface. Refer to section [19.5.1 MIO Programming](#).

3. **Configure UART_Ref_Clk:** The UART clock architecture and programming model are described in section [19.4.1 Clocks](#).
4. **Configure controller functions:** Program the I/O signal characteristics and controller functions using the `uart.Control_reg0` and `uart.mode_reg0` registers. Examples are shown in section [19.3.2 Configure Controller Functions](#).
5. **Configure interrupts:** Interrupts are used to manage the Rx/Tx FIFOs in all modes. Refer to section [19.2.10 Status and Interrupts](#) and the program example in section [19.3.5 RxFIFO Trigger Level Interrupt](#).
6. **Configure modem controls (optional):** Polling and interrupt driven options. Refer to section [19.2.11 Modem Control](#).
7. **Manage transmit and receive data:** Polling and interrupt driven handlers are supportable. Refer to sections [19.3.3 Transmit Data](#) and [19.3.4 Receive Data](#).

19.3.2 Configure Controller Functions

Example: Configure Controller Functions

This example configures the character frame, the baud rate, the FIFO trigger levels, the Rx timeout mechanism, and enables the controller. All of these steps are necessary after a reset, but not necessary between enabling and disabling the controller.

1. **Configure UART character frame.** Write `0x0000_0020` into the `uart.mode_reg0`:
 - a. Disables clock pre-divider, `UART_REF_CLK/8`: `[CLKS] = 0`
 - b. Selects 8-bit character length: `[CHRL] = 00`
 - c. Selects no parity: `[PAR] = 100`
 - d. Selects 1 stop bit: `[NBSTOP] = 00`
 - e. Selects normal channel mode (Mode Switch): `[CHMODE] = 00`
2. **Configure the Baud Rate.** Write to three registers: `uart.Control_reg0`, `uart.Baud_rate_gen_reg0`, and `uart.Baud_rate_divider_reg0`. Examples for the calculated CD and BDIV values are shown in [Table 19-1, page 584](#). The baud rate generator is described in section [19.2.3 Baud Rate Generator](#).
 - a. Disable the Rx path: set `uart.Control_reg0 [RXEN] = 0` and `[RXDIS] = 1`.
 - b. Disable the Tx path: set `uart.Control_reg0 [TXEN] = 0` and `[TXDIS] = 1`.
 - c. Write the calculated CD value into the `uart.Baud_rate_gen_reg0 [CD]` bit field.
 - d. Write the calculated BDIV value into the `uart.Baud_rate_divider_reg0 [BDIV]` bit value.
 - e. Reset Tx and Rx paths: `uart.Control_reg0 [TXRST]` and `[RXRST] = 1`. These bits are self-clearing.
 - f. Enable the Rx path: Set `[RXEN] = 1` and `[RXDIS] = 0`.
 - g. Enable the Tx path: Set `[TXEN] = 1` and `[TXDIS] = 0`.
3. **Set the level of the RxFIFO trigger level.** Write the trigger level into the `uart.Rcvr_FIFO_trigger_level0` register.
 - Option a: **Enable the Rx trigger level:** Write a value of 1 to 63 into the `[RTRIG]` bit field.

- Option b: **Disable the Rx trigger level:** Write 0 into the [RTRIG] bit field.
4. **Enable the Controller.** Write `0x0000_0117` into the `uart.Control_reg0` register.
 - a. Reset Tx and Rx paths: `uart.Control_reg0 [TXRST]` and `[RXRST] = 1`. These bits are self-clearing.
 - b. Enables the Rx path: `[RXEN] = 1` and `[RXDIS] = 0`.
 - c. Enables the Tx path: `[TXEN] = 1` and `[TXDIS] = 0`.
 - d. Restarts the Receiver Timeout Counter: `[RSTTO] = 1`.
 - e. Does not start to transmit a break: `[STTBK] = 0`.
 - f. Stop Break transmitter: `[STPBK] = 1`
 5. **Program the Receiver Timeout Mechanism.** Write the timeout value into the `uart.Rcvr_timeout_reg0` register. Refer to [Receiver Timeout Mechanism, page 586](#).
 - a. To enable the timeout mechanism, write a value of 1 to 255 into the [RSTTO] bit field.
 - b. To disable the timeout mechanism, write a 0 into the [RSTTO] bit field.

19.3.3 Transmit Data

Software can use polling or interrupts to control the flow of data to the Tx FIFO and Rx FIFO.

Note: When the Tx FIFO Empty status is true, software can write 64 bytes (the size of the Tx FIFO) without checking the Tx FIFO status. In reality, software can write more than 64 bytes when the transmitter is active because while the software is writing data to the Tx FIFO, the controller is removing data and serializing it onto the Tx signal.

Example: Transmit Data using the Polling Method

In this example, the software can choose to fill the Tx FIFO until the Full status bit is set or wait for the Tx FIFO to be empty (and write up to 64 bytes). The software can always write a byte when the Tx FIFO is nearly full.

1. **Check to see if the Tx FIFO is empty.** Wait until `uart.Channel_sts_reg0[EMPTY] = 1`.
2. **Fill the Tx FIFO with data.** Write 64 bytes of data to the `uart.TX_RX_FIFO0` register.
3. **Write more data to the Tx FIFO.** There are two methods:

Option A: **Check to see if the Tx FIFO has room to another byte of data (i.e., the Tx FIFO is not full):** Read `uart.Channel_sts_reg0 [TFUL]` until it equals 0. When `[TFUL] = 0`, write a single byte of data into the Tx FIFO and then read `[TFUL]` again.

Option B: **Wait until the Tx FIFO goes empty.** Read `uart.Channel_sts_reg0 [EMPTY]` until it equals 1, then go to step 2 to fill the Tx FIFO with 64 bytes of data.

Example: Transmit Data using the Interrupt Method

This example initially fills the Tx FIFO in a similar way as the polling method. Then, software enables the Tx FIFO Empty interrupt to alert the software to fill-up the Tx FIFO again.

1. **Disable the Tx FIFO Empty interrupt.** Write a 1 to `uart.Intrpt_dis_reg0 [EMPTY]`.

2. **Fill the TxFIFO with data.** Write 64 bytes of data to the `uart.TX_RX_FIFO0` register.
3. **Check to see if the TxFIFO has room to another byte of data (i.e., the TxFIFO is not full):** read `uart.Channel_sts_reg0 [TFUL]` until it equals 0. When `[TFUL] = 0`, write a single byte of data into the TxFIFO and then read `[TFUL]` again.
4. **Repeat step 2 and 3.** Repeat until `uart.Channel_sts_reg0 [TFUL]` is not set.
5. **Enable the interrupt.** Enable the interrupt with a write of 1 to `uart.Intrpt_en_reg0 [EMPTY]`.
6. **Wait until the TxFIFO is empty.** Repeat from step 1 when `uart.Channel_int_sts_reg0 [EMPTY]` is set to 1.

19.3.4 Receive Data

Example: Receive Data using the Polling Method

1. **Wait until the RxFIFO is filled up to the trigger level.** Check to see if `uart.Channel_sts_reg0[RTRIG] = 1` or `uart.Chnl_int_sts_reg0 [TIMEOUT] = 1`.
2. **Read data from the RxFIFO.** Read data from the `uart.TX_RX_FIFO0` register.
3. **Repeat step 2 until FIFO is empty.** Check that `uart.Channel_sts_reg0 [EMPTY] = 1`.
4. **Clear if Rx timeout interrupt status bit is set.** Write 1 to `Chnl_int_sts_reg0 [TIMEOUT]`.

Example: Receive Data using the Interrupt Method

1. **Enable interrupts.** Write a 1 to `uart.Intrpt_en_reg0 [TIMEOUT]` and `uart.Intrpt_en_reg0[RTRIG]`.
2. **Wait until the RxFIFO is filled up to the trigger level or Rx timeout.** Check that `uart.Chnl_int_sts_reg0 [RTRIG] = 1` or `uart.Chnl_int_sts_reg0 [TIMEOUT] = 1`.
3. **Read data from the RxFIFO.** Read data from the `uart.TX_RX_FIFO0` register.
4. **Repeat step 2 and 3 until the FIFO is empty.** Check that `uart.Channel_sts_reg0 [EMPTY] = 1`.
5. **Clear the interrupt status bits if set.** Write a 1 to `Chnl_int_sts_reg0 [TIMEOUT]` or `Chnl_int_sts_reg0 [RTRIG]`.

19.3.5 RxFIFO Trigger Level Interrupt

Example: Set the RxFIFO Trigger Level and Enable the Interrupt

The `Intrpt_en_reg0` register has bits to enable the interrupt mask and `Intrpt_dis_reg0` has bits to forcefully disable the interrupts. Each pair of bits should be set mutually exclusive (i.e., one register has a 1 for the bit and the other register has a 0):

- `Intrpt_en_reg0`: Write-only. Enable interrupt bit(s).
 - `Intrpt_dis_reg0`: Write-only. Force disable of interrupt bit(s).
1. **Program the Trigger Level.** Write to the 6-bit field, `uart.Rcvr_FIFO_trigger_level0[RTRIG]`.
 2. **Enable the RTRIG interrupt.** Set the enable bit, clear the disable bit, and verify the mask value:
 - a. Set `uart.Intrpt_en_reg0[RTRIG] = 1`.

- b. Clear `uart.Intrpt_dis_reg0[RTRIG] = 0`.
- c. The `uart.intrpt_mask_reg0[RTRIG]` read back = 1 (enabled interrupt).
- 3. **Disable the RTRIG interrupt.** Set the disable bit, clear the enable bit, and verify the mask value:
 - a. Set `uart.Intrpt_dis_reg0[RTRIG] = 1`.
 - b. Clear `uart.Intrp_en_reg0[RTRIG] = 0`.
 - c. The `uart.intrpt_mask_reg0[RTRIG]` read back = 0 (disabled interrupt).
- 4. **Clear the RTRIG interrupt.** Write a one to the `uart.Intrpt_dis_reg0[RTRIG]` bit field.

When both the enable and disable bits are set for an interrupt, the interrupt is disabled.

The state of the interrupt enable/disable mechanism can be determined by reading the `uart.Intrpt_mask_reg0` register. If the mask bit = 1, then the interrupt is enabled.

19.3.6 Register Overview

An overview of the UART registers is shown in [Table 19-3](#). Details are provided in [Appendix B, Register Details](#).

Table 19-3: UART Register Overview

| Function | uart. Register Names | Overview |
|----------------------|--|---|
| Configuration | Control_reg0 mode_reg0 Baud_rate_gen_reg0 Baud_rate_divider_reg0 | Configure mode and baud rate. |
| Interrupt processing | Intrpt_en_reg0 Intrpt_dis_reg0 Intrpt_mask_reg0 Chnl_int_sts_reg0 Channel_sts_reg0 | Enable/disable interrupt mask, channel interrupt status, channel status |
| Rx and Tx Data | TX_RX_FIFO0 | Read data Received. Write data to be Transmitted. |
| Receiver | Rcvr_timeout_reg0 Rcvr_FIFO_trigger_level0 | Configure receiver timeout and RxFIFO trigger level value. |
| Transmitter | Tx_FIFO_trigger_level0 | Configure TxFIFO trigger level value. |
| Modem | Modem_ctrl_reg0 Modem_sts_reg0 Flow_delay_reg0 | Configure modem-like application. |

19.4 System Functions

19.4.1 Clocks

The controller and I/O interface are driven by the reference clock (UART_REF_CLK). The controller's interconnect also requires an APB interface clock (CPU_1x). Both of these clocks always come from the PS clock subsystem.

CPU_1x Clock

Refer to section 25.2 [CPU Clock](#), for general clock programming information. The CPU_1x clock runs asynchronous to the UART reference clock.

Reference Clock

The generation of the reference clock in the PS clock subsystem is controlled by the slcr.UART_CLK_CTRL register. This register can select the PLL that the clock is derived from and sets the divider frequency. This register also controls the clock enables for each UART controller. The generation of the UART reference clock is described in section 25.6.3 [SDIO, SMC, SPI, Quad-SPI and UART Clocks](#).

Operating Restrictions

Note: The clock operating restrictions are described in section 19.1.3 [Notices](#).

Example: Configure Reference Clock

The clock can be based on any of the PLLs in the PS clock subsystem. In this example, the I/O PLL is used with a 1,000 MHz clock and the clock divisor is 0x14 to generate a 50 MHz clock for the UART controllers.

1. **Program the UART Reference clock.** Write 0x0000_1401 to the slcr.UART_CLK_CTRL register.
 - a. Clock divisor, slcr.UART_CLK_CTRL[DIVISOR] = 0x14.
 - b. Select the IO PLL, slcr.UART_CLK_CTRL[SRCSEL] = 0.
 - c. Enable the UART 0 Reference clock, slcr.UART_CLK_CTRL [CLKACT0] = 1.
 - d. Disable UART 1 Reference clock, slcr.UART_CLK_CTRL [CLKACT1] bit = 0.

19.4.2 Resets

The controller reset bits are generated by the PS, see [Chapter 26, Reset System](#).

Example: Controller Reset

Option 1. **Assert Controller Reset:** Set both `slcr.UART_RST_CTRL[UARTx_REF_RST, UARTx_CPU1X_RST]` bits = 1.

Option 2. **De-assert Controller Reset:** Clear both `slcr.UART_RST_CTRL[UARTx_REF_RST, UARTx_CPU1X_RST]` bits = 0.

19.5 I/O Interface

19.5.1 MIO Programming

The UART RxD and TxD signals can be routed to one of many sets of MIO pins or to the EMIO interface. All of the modem flow control signals are always routed to the EMIO interface and are not available on the MIO pins. All of the UART signals are listed in [Table 19-4](#). The routing of the RxD and TxD signals are described in section [2.4 PS-PL Voltage Level Shifter Enables](#).

Example: Route UART 0 RxD/TxD Signals to MIO Pins 46, 47

In this example, the UART 0 RxD and TxD signals are routed through MIO pins 46 and 47. Many other pin options are possible.

- Configure MIO pin 46 for the RxD signal.** Write `0x0000_12E1` to the `slcr.MIO_PIN_46` register:
 - Route UART 0 RxD signal to pin 46.
 - Output disabled (set `TRI_ENABLE = 1`).
 - LVC MOS18 (refer to the register definition for other voltage options).
 - Slow CMOS edge (benign setting).
 - Enable internal pull-up resistor.
 - Disable HSTL receiver.
- Configure MIO pin 47 for the TxD signal.** Write `0x0000_12E0` to the `slcr.MIO_PIN_47` register:
 - Route UART 0 TxD signal to pin 47.
 - 3-state controlled by the UART (`TRI_ENABLE = 0`).
 - LVC MOS18 (refer to the register definition for other voltage options).
 - Slow CMOS drive edge.
 - Enable internal pull-up resistor.
 - Disable HSTL receiver.

19.5.2 MIO – EMIO Signals

The UART I/O signals are identified in Table 19-4. The MIO pins and any restrictions based on device versions are shown in the MIO table in section 2.5.4 MIO-at-a-Glance Table.

Table 19-4: UART MIO Pins and EMIO Signals

| UART Interface Signal | Default Controller Input Value | MIO Pins | I/O | EMIO Signals | |
|----------------------------|--------------------------------|---|-----|---------------|-----|
| | | Numbers | | Name | I/O |
| UART 0 Transmit | ~ | 11, 15, 19, 23, 27, 31, 35, 39, 43, 47, 51 | O | EMIOUART0TX | O |
| UART 0 Receive | | 10, 14, 18, 22, 26, 30, 34, 38, 42, 46, 50 | I | EMIOUART0RX | I |
| UART 0 Clear to Send | | ~ | ~ | EMIOUART0CTSN | I |
| UART 0 Ready to Send | ~ | ~ | ~ | EMIOUART0RTSN | O |
| UART 0 Data Set Ready | | ~ | ~ | EMIOUART0DSRN | I |
| UART 0 Data Carrier Detect | | ~ | ~ | EMIOUART0DCDN | I |
| UART 0 Ring Indicator | | ~ | ~ | EMIOUART0RIN | I |
| UART 0 Data Terminal Ready | ~ | ~ | ~ | EMIOUART0DTRN | O |
| UART 1 Transmit | ~ | 8, 12, 16, 20, 24, 28, 32, 36, 40, 44, 48, 52 | O | EMIOUART1TX | O |
| UART 1 Receive | | 9, 13, 17, 21, 25, 29, 33, 37, 41, 45, 49, 53 | I | EMIOUART1RX | I |
| UART 1 Clear to Send | | ~ | ~ | EMIOUART1CTSN | I |
| UART 1 Ready to Send | ~ | ~ | ~ | EMIOUART1RTSN | O |
| UART 1 Data Set Ready | | ~ | ~ | EMIOUART1DSRN | I |
| UART 1 Data Carrier Detect | | ~ | ~ | EMIOUART1DCDN | I |
| UART 1 Ring Indicator | | ~ | ~ | EMIOUART1RIN | I |
| UART 1 Data Terminal Ready | ~ | ~ | ~ | EMIOUART1DTRN | O |

I2C Controller

20.1 Introduction

This I2C module is a bus controller that can function as a master or a slave in a multi-master design. It supports an extremely wide clock frequency range from DC (almost) up to 400 Kb/s.

In master mode, a transfer can only be initiated by the processor writing the slave address into the I2C address register. The processor is notified of any available received data by a data interrupt or a transfer complete interrupt. If the HOLD bit is set, the I2C interface holds the SCL line Low after the data is transmitted to support slow processor service. The master can be programmed to use both normal (7-bit) addressing and extended (10-bit) addressing modes.

In slave monitor mode, the I2C interface is set up as a master and continues to attempt a transfer to a particular slave until the slave device responds with an ACK.

The HOLD bit can be set to prevent the master from continuing with the transfer, preventing an overflow condition in the slave.

A common feature between master mode and slave mode is the timeout (TO) interrupt flag. If at any point the SCL line is held Low by the master or the accessed slave for more than the period specified in the Timeout register, a timeout (TO) interrupt is generated to avoid stall conditions.

20.1.1 Features

The PS supports two I2C devices with these key features:

- I2C bus specification version 2
- Supports 16-byte FIFO
- Programmable normal and fast bus data rates
- Master mode
 - Write transfer
 - Read transfer
 - Extended address support
 - Clock stretching by allowing hold for slow processor service.
 - Supports TO interrupt flag to avoid stall condition.
- Slave monitor mode

- Slave mode
 - Slave transmitter
 - Slave receiver
 - Fully programmable slave response address
 - Supports HOLD to prevent overflow condition
 - Supports TO interrupt flag to avoid stall condition
 - Clock stretching to delay communication if data is not readily available.
- Software can poll for status or function as interrupt-driven device
- Programmable interrupt generation

20.1.2 System Block Diagram

The system viewpoint diagram for the I2C module is shown in [Figure 20-1](#).

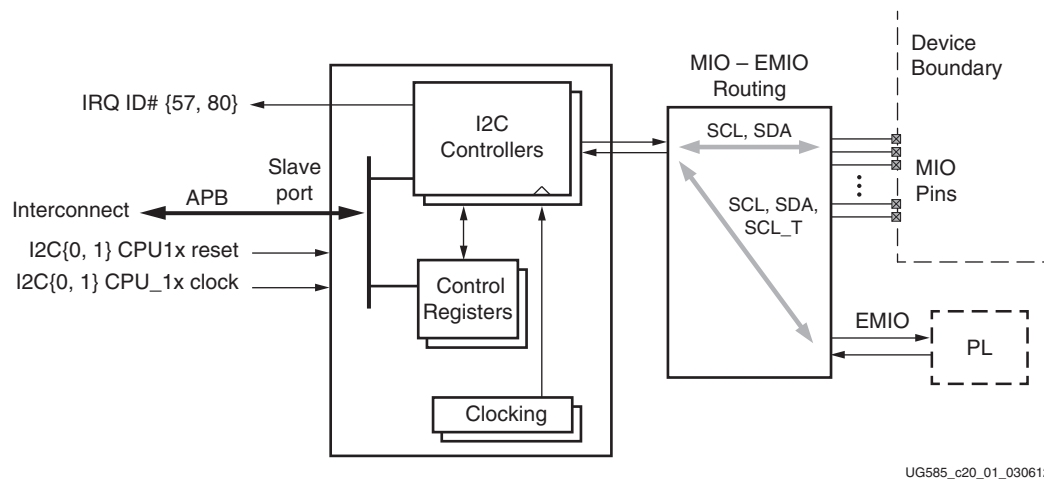

Figure 20-1: I2C System Block Diagram

20.1.3 Notices

7z007s and 7z010 CLG225 Devices

The 7z007s single core and 7z010 dual core CLG225 devices support 32 MIO pins as shown in section [2.5.4 MIO-at-a-Glance Table](#). This restricts the availability of the I2C signals on the MIO pins. As needed, I2C signals can be routed through the EMIO interface and passed-through to the PL pins. All CLG225 device restrictions are listed in section [1.1.3 Notices](#).

20.2 Functional Description

20.2.1 Block Diagram

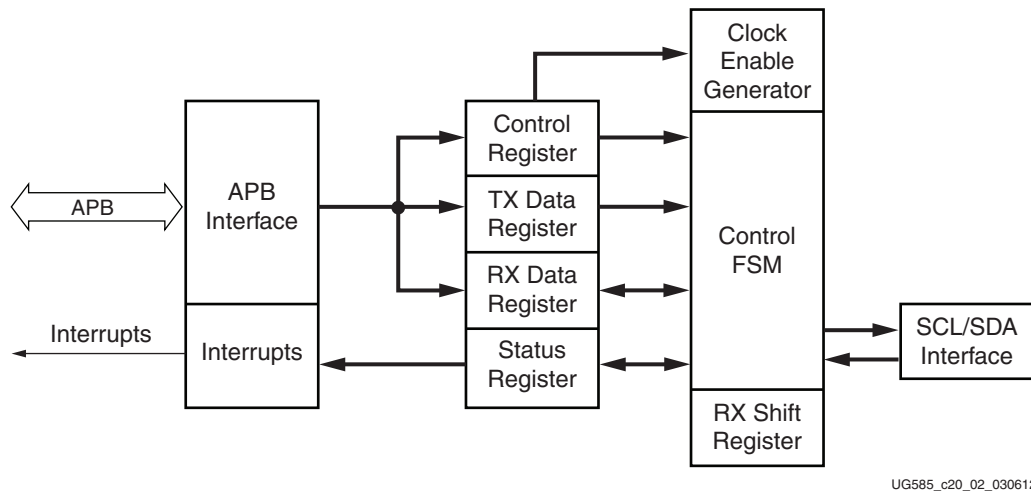

Figure 20-2: I2C Peripheral Block Diagram

20.2.2 Master Mode

An I2C transfer can only be initiated by the APB host, and two types of transfers can be performed:

- Write transfer, where the I2C becomes master transmitter
- Read transfer, where the I2C becomes master receiver

Write Transfer

To accomplish an I2C write transfer, the host must perform these steps:

1. Write to the control register to set up SCL speed and addressing mode.
2. Set the MS, ACKEN, and CLR_FIFO bits and clear the RW bit in the Control register.
3. If required, set the HOLD bit. Otherwise write the first byte of data to the I2C Data register.
4. Write the slave address into the I2C address register. This initiates the I2C transfer.
5. Continue to load the remaining data to be sent to the slave by writing to the I2C Data register. The data is pushed in the FIFO each time the host writes to the I2C Data register.

When all data is transferred successfully, the COMP bit is set in the interrupt status register. A data interrupt is generated whenever there are only two bytes left for transmission in the FIFO.

When all data is transferred successfully, if the HOLD bit is not set, the I2C interface generates a STOP condition and terminates the transfer. If the HOLD bit is set, the I2C interface holds the SCL line Low

after the data is transmitted. The host is notified of this event by a transfer complete interrupt (COMP bit set) and the TXDV bit in the status register is cleared. At this point, the host can proceed in three ways:

1. Clear the HOLD bit. This causes the I2C interface to generate a STOP condition.
2. Supply more data by writing to the I2C address register. This causes the I2C interface to continue with the transfer, writing more data to the slave.

If at any point the slave responds with a NACK, the transfer automatically terminates and a transfer NACK interrupt is generated (the NACK bit set). When a NACK is received the Transfer Size register indicates the number of bytes that still need to be sent minus one. Unless the very last byte written by the host into the FIFO was a NACK byte, TXDV remains High. In this case, the host must clear the FIFO by setting the CLR_FIFO bit in the Control register.

If at any point the SCL line is held Low by the master or the accessed slave for more than the period specified in the Timeout register, a TO interrupt is generated and the outstanding amount of data minus one is then read from the Transfer Size register.

Read Transfer

To accomplish an I2C read transfer, the host must perform these steps:

1. Write to the Control register to set up the SCL speed and addressing mode.
2. Set the MS, ACKEN, CLR_FIFO bits, and the RW bit in the Control register.
3. If the host wants to hold the bus after the data is received, it must also set the HOLD bit.
4. Write the number of requested bytes in the Transfer Size register.
5. Write the slave address in the I2C Address register. This initiates the I2C transfer.

The host is notified of any available received data in two ways:

1. If an outstanding transfer size is equal to or greater than the FIFO size -2, a data interrupt is generated (DATA bit set) when there are two free locations available in the FIFO.
2. If an outstanding transfer size is less than FIFO size -2, a transfer complete interrupt is generated (COMP bit set) when the outstanding transfer size bytes are received.

In both cases, the RXDV bit in the status register is set.

The I2C interface automatically returns a NACK after receiving the last expected byte and terminates the transfer by generating a STOP condition. If the HOLD bit is set during a master read transfer, the I2C interface drives the SCL line Low.

If at any point the slave responds with NACK while the master transmits a slave address for a master read transfer, the transfer automatically terminates and a transfer NACK interrupt is generated (NACK bit is set). The outstanding amount of data can be read from the Transfer Size register.

If at any point the SCL line is held Low by the master or the accessed slave for more than the period specified in the Timeout register, a TO interrupt is generated.

20.2.3 Slave Monitor Mode

This mode is meaningful only when the module is in master mode and bit SLVMON in the control register is set. The host must set the MS and SLVMON bits and clear the RW bit in the Control register. Also, it must initialize the Slave Monitor Pause register.

The master attempts a transfer to a particular slave whenever the host writes to the I2C Address register. If the slave returns a NACK when it receives the address, the master waits for the time interval established by the Slave Monitor Pause register and attempts to address the slave again. The master continues this cycle until the slave responds with an ACK to its address or until the host clears the SLVMON bit in the Control register. If the addressed slave responds with an ACK, the I2C interface terminates the transfer by generating a STOP condition and a SLV_RDY interrupt.

20.2.4 Slave Mode

The I2C interface is set up as a slave by clearing the MS bit in the Control register. The I2C slave must be given a unique identifying address by writing to the I2C address register. The SCL speed must also be set up at least as fast as the fastest SCL frequency expected to be seen. When in slave mode, the I2C interface operates as either a slave transmitter or a slave receiver.

Slave Transmitter

The slave becomes a transmitter after recognizing the entire slave address sent by the master and when the R/W field in the last address byte sent is High. This means that the slave has been requested to send data over the I2C bus and the host is notified of this through an interrupt through an interrupt to the GIC (refer to [Figure 20-1, page 602](#)). At the same time, the SCL line is held Low to allow the host to supply data to the I2C slave before the I2C master starts sampling the SDA line. The host is notified of this event by setting the DATA interrupt flag.

At the same time, the SCL line is held Low to allow the host to supply data to the I2C slave before the I2C master starts sampling the SDA line.

The host must supply data for transmission through the I2C data register so that the SCL line is released and transfer continues. If it does not write to the I2C data register before the timeout period expires, an interrupt is generated and a TO interrupt flag is set.

After the host writes to the I2C data register, the transfer continues by loading data in the FIFO while the transfer is in progress. The amount of data loaded in the FIFO might be a known system parameter or communicated in advance through a higher level protocol using the I2C bus.

When there are only two valid bytes left in the FIFO for transmission, an interrupt is generated and the DATA interrupt flag is set. If the I2C master returns a NACK on the last byte transmitted from the FIFO, an interrupt is generated, and the COMP interrupt flag is set as soon as the I2C master generates a STOP condition.

The transfer must continue if the master acknowledges on the last byte sent out from the FIFO. At that moment, the DATA interrupt flag is set. The TXDV flag in the Status register is cleared because the FIFO is empty.

If the I2C master terminates the transfer before all of the data in the FIFO is sent by the slave, the host is notified, and the NACK interrupt flag is set while TXDV remains set and the Transfer Size register indicates the remaining bytes in the FIFO. The host must set the CLR_FIFO bit in the Control register to clear the FIFO and the TXDV bit.

Slave Receiver

The slave becomes a receiver after recognizing the entire slave address sent by the master and when the R/W bit in the first address byte is Low. This means that the master is about to send one or more data bytes to the slave over the I2C bus.

After a byte is acknowledged by the I2C slave, the RXDV bit in the Status register is set, indicating that new data has been received. The host reads the received data through the I2C Data register. An interrupt is generated and the DATA interrupt flag is set when there are only two free locations left in the FIFO.

Whenever the I2C master generates a STOP condition, an interrupt is generated and the COMP interrupt flag is set. The Transfer Size register then contains the number of bytes received that are available in the FIFO. This number is decremented by the host on each read of the I2C Data register.

If the FIFO is full when one or more bytes are received by the I2C interface, an interrupt is generated and the RX_OVF interrupt flag is set. The last byte received is not acknowledged and the data in the FIFO is kept intact.

The HOLD bit can be set in the Control register to avoid overflow conditions when it is impossible to respond to interrupts in a reasonable time. If the HOLD bit is set, the I2C interface keeps the SCL line Low until the host clears resources for data reception. This prevents the master from continuing with the transfer, causing an overflow condition in the slave. The host clears resources for data reception by reading the data register.

If the HOLD bit is set and the I2C interface keeps the SCL line Low for longer than the timeout period, an interrupt is generated and the TO interrupt flag is set.

20.2.5 I2C Speed

The main clock used within the I2C interface is the clock enable signal (see [Figure 20-3](#)).

- In slave mode, the clock enable is used to extract synchronization information for correct sampling of the SDA line.
- In master mode, the clock enable is used to establish a time base for generating the desired SCL frequency.

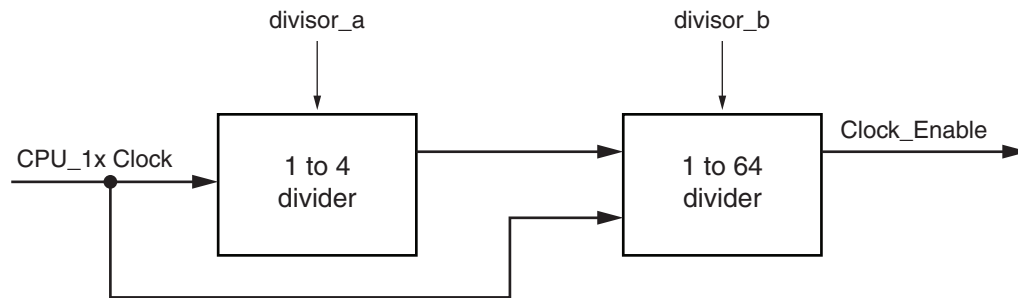

UG585_c20_03_022912

Figure 20-3: I2C Clock Generator

The frequency of the clock_enable signal is defined by the frequency of the CPU_1x clock and the values of divisor_a and divisor_b using Equation 20-1

$$FreqClock_Enable = \frac{FreqCPU_1x}{(divisor_a + 1) \times (divisor_b + 1)} \quad \text{Equation 20-1}$$

Note: As seen from the above calculation, the SCL clock frequency range is limited by the cpu_1x clock. This means that for some cpu_1x clock rates there will be some SCL frequencies that are not possible.

See I2C register map in [Appendix B, Register Details](#) for details of register fields.

Table 20-1 lists the calculated values for standard and high speed SCL clock values. A programming example is provided in Section 20.3.2.

$$I2C\ SCL\ Clock = CPU_1X_Clock / (22 * (divisor_a + 1) * (divisor_b + 1))$$

Table 20-1: Calculated Values for Standard and High Speed SCL Clock Values

| I2C SCL Clock | CPU_1X_Clock | divisor_a | divisor_b |
|---------------|--------------|-----------|-----------|
| 100 KHz | 111 MHz | 2 | 16 |
| 400 KHz | 111 MHz | 0 | 12 |
| 100 KHz | 133 MHz | 0 | 60 |
| 400 KHz | 133 MHz | 2 | 4 |
| 100 KHz | 166 MHz | 3 | 16 |

20.2.6 Multi-Master Operation

In I2C multi master mode, the bus is shared with other masters. In this mode, the I2C clock (I2C_SCL) is driven by the device that acts as the master.

20.2.7 I2C0-to-I2C1 Connection

The I/O signals of the two I2C controllers in the PS are connected together when the slcr.MIO_LOOPBACK [I2C0_LOOP_I2C1] bit is set = 1. In this mode, the serial clocks are connected together and the serial data signals are connected together.

20.2.8 Status and Interrupts

The registers i2c.Interrupt_status_reg0, i2c.Intrpt_mask_reg0, i2c.Intrpt_enable_reg0 and i2c.Intrpt_disable_reg0 provide interrupt capability. See Table 20-2 for Interrupt and Status register names and bit assignments.

Table 20-2: Interrupt and Status Register Names and Bit Assignments

| 15 | 14 | 13 | 12 | 11 | 10 | 9 | 8 | 7 | 6 | 5 | 4 | 3 | 2 | 1 | 0 |
|---------------------------|----|----|----|----|----|----------|----|--------|--------|--------|---------|-------|------|------|------|
| | | | | | | | | | | | | | | | |
| i2c.Interrupt_status_reg0 | | | | | | | | | | | | | | | |
| i2c.Intrpt_mask_reg0 | | | | | | | | | | | | | | | |
| i2c.Intrpt_enable_reg0 | | | | | | | | | | | | | | | |
| i2c.Intrpt_disable_reg0 | | | | | | | | | | | | | | | |
| X | X | X | X | X | X | ARB_LOST | X | RX_UNF | TX_OVF | RX_OVF | SLV_RDY | TO | NACK | DATA | COMP |
| i2c.Status_reg0 | | | | | | | | | | | | | | | |
| X | X | X | X | X | X | X | BA | RXOVF | TXDV | RXDV | X | RX_RW | X | X | X |

Interrupt Mask Register

Intrpt_mask_reg0 is a read-only interrupt mask register used to enable/disable individual interrupts in the i2c.interrupt_status_reg0 register:

- If the mask bit = 0, the interrupt is enabled.
- If the mask bit = 1, the interrupt is disabled.

This mask is controlled by the write-only Intrpt_enable_reg0 and Intrpt_disable_reg0 registers.

Each associated enable/disable interrupt bit should be set mutually exclusive (e.g., to enable an interrupt, write 1 to Intrpt_enable_reg0[x] and write 0 to Intrpt_disable_reg0[x]).

Interrupt Status Register

All the bits are sticky.

- Read: Reads interrupt status.
- Write: Write 1 to clear

Status Register

All bits present the raw status of the interface. Bits in this register dynamically change based on FIFO and other conditions.

Limitation

The I2C controller registers require single 32-bit read/write accesses, do not use byte, halfword, or double word references.

20.3 Programmer's Guide

20.3.1 Start-up Sequence

1. **Reset controller:** Programming resets is described in section [20.4.2 Reset Controller](#).
2. **Configure I/O signal routing:** I2C signals SCL and SDA can be routed to either MIO or EMIO. Refer to [Table 20-4](#). Example of I2C SCL and SDA signal routed to MIO is provided in section [20.5.1 Pin Programming](#).
3. **Configure Clocks:** The I2C clock architecture is described in section [20.4.1 Clocks](#).
4. **Controller Configuration:** Program I2C transfer parameters using `i2c.Control_reg0` etc. Refer to section [20.4.2 Reset Controller](#).
5. **Configure Interrupts:** Interrupts help to control data in FIFO. Refer to section [20.2.8 Status and Interrupts](#) and programming example in section [20.3.3 Configure Interrupts](#).
6. **Data Transfers:** Transfers in master mode and slave monitor mode can be referred in section [20.3.4 Data Transfers](#).

20.3.2 Controller Configuration

The user should choose interface mode, addressing mode, direction of transfer, timeout, and program the I2C bus speed before initiating an I2C transfer. Optionally, the user can clear FIFOs and hold the bus if required, in case of large data or combined transfers.

Example: Master Write Transfer

1. **Configure the Control parameters.** Write `0x0000_324E` to the `i2c.Control_reg0` register:
 - a. Select Master mode: Set `i2c.Control_reg0[MS] = 1`.

- b. Set Direction of transfer as Master Transmitter: Set `i2c.Control_reg0[RW] = 0`.
- c. Select Normal Addressing [7-bit] mode: Set `i2c.Control_reg0[NEA] = 1`.
- d. Enable the transmission of ACK: Set `i2c.Control_reg0[ACKEN] = 1`.
- e. Clear the FIFOs: Set `i2c.Control_reg0[CLR_FIFO] = 1`.
- f. Program the clock divisors:
 - Set `i2c.Control_reg0[divisor_a] = 0`.
 - Set `i2c.Control_reg0[divisor_b] = 50`.

These divisors generate an I2C SCL of 99 KHz using the CPU_1X clock of 111 MHz. For further details refer to section [20.2.5 I2C Speed](#).

2. **Configure Timeout.** Write `0x0000_00FF` to the `i2c.Time_out_reg0` register. Wait 255 SCL cycles when the SCL is held Low, before generating a timeout interrupt.

20.3.3 Configure Interrupts

The interrupts are described in section [20.2.8 Status and Interrupts](#). The `i2c.Intrpt_enable_reg0` register has bits to enable the interrupt mask and `i2c.Intrpt_disable_reg0` has bits to forcefully disable the interrupts. Each pair of bits should be set mutually exclusive:

Example: Program Example to Configure Completion Interrupt

1. **Enable the completion interrupt.** Set the enable bit, clear the disable bit, and verify the mask value:
 - a. Set `i2c.Intrpt_enable_reg0[COMP] = 1`.
 - b. Clear `i2c.Intrpt_disable_reg0[COMP] = 0`.
 - c. `i2c.intrpt_mask_reg0[COMP]` reads back = 1.
2. **Disable the completion interrupt.** Set the enable bit, clear the disable bit, and verify the mask value:
 - a. Set `i2c.Intrpt_disable_reg0[COMP] = 1`.
 - b. Clear `i2c.Intrpt_enable_reg0[COMP] = 0`.
 - c. `i2c.Intrpt_mask_reg0[COMP]` reads back = 0.
3. **Monitor completion interrupt.** `i2c.Interrupt_status_reg0` provides status of completion interrupt.:
 - a. Read `i2c.Interrupt_status_reg0 [COMP]`. 1 indicates that an interrupt occurred.
4. **Clear completion interrupt.** Write 1 to the `i2c.Interrupt_status_reg0[COMP]` bit field.

20.3.4 Data Transfers

Transfers can be achieved in polled mode or interrupt driven mode. Limitation on data count while performing a master read transfer is 255 bytes. Below are examples of read and write transfer in Master mode and example for Slave Monitor mode. Refer to section [20.2.3 Slave Monitor Mode](#) for details.

Example: Master Read Using Polled Method

1. **Set direction of transfer as read and clear the FIFOs.** Write 0×41 to `i2c.Control_reg0`.
2. **Clear interrupts.** Read and write back the read value to `i2c.Interrupt_status_reg0`.
3. **Write read data count to transfer size register and hold bus if required.** Write read data count value to `i2c.Transfer_size_reg0`. If read data count greater than FIFO depth, set `i2c.Control_reg0 [HOLD] = 1`.
4. **Write the slave address.** Write the address to the `i2c.I2C_address_reg0` register.
5. **Wait for data to be received into the FIFO.** Poll on `i2c.Status_reg0 [RXDV] = 1`.
 - a. If `i2c.Status_reg0 [RXDV] = 0`, and any of `i2c.Interrupt_status_register [NACK]`, `i2c.Interrupt_status_register [ARB_LOST]`, `i2c.Interrupt_status_register [RX_OVF]`, `i2c.Interrupt_status_register [RX_UNF]` interrupts are set, then stop the transfer and report the error, otherwise continue to poll on `i2c.Status_reg0 [RXDV]`.
 - b. If `i2c.Status_reg0 [RXDV] = 1`, and if any of `i2c.Interrupt_status_register [NACK]`, `i2c.Interrupt_status_register [ARB_LOST]`, `i2c.Interrupt_status_register [RX_OVF]`, `i2c.Interrupt_status_register [RX_UNF]` interrupts are set, then stop the transfer and report the error. Otherwise, go to step 6.
6. **Read data and update count.** Read data from FIFO until `i2c.Status_reg0[RXDV] = 1`. Decrement the read data count and if it is less than or equal to the FIFO depth, clear `i2c.Control_reg0[HOLD]`.
7. **Check for Completion of transfer.** If total read count reaches zero, poll on `i2c.Interrupt_status_reg0 [COMP] = 1`. Otherwise continue from step 5.

Example: Master Write Using Polled Method

1. **Set Direction of transfer as write and Clear the FIFO's.** Write 0×40 to `i2c.Control_reg0`.
2. **Clear Interrupts.** Read and write back the read value to `i2c.Interrupt_status_reg0`.
3. **Calculate the space available in FIFO.** Subtract `i2c.Transfer_size_reg0` value from FIFO depth.
4. **Fill the data into FIFO.** Write the data to `i2c.I2C_data_reg0` based on the count obtained in step 3.
5. **Write the Slave Address.** Write the address to `i2c.I2C_address_reg0` register.
6. **Wait for TX FIFO to be empty.** Poll on `i2c.Status_reg0 [TXDV] = 0`.
 - a. If `i2c.Status_reg0 [TXDV] = 1`, any of `i2c.Interrupt_status_register [NACK]`, `i2c.Interrupt_status_register [ARB_LOST]`, `i2c.Interrupt_status_register [RX_OVF]`, `i2c.Status_register [TX_OVF]` are set, then stop the transfer and report the error otherwise continue to poll.
 - b. If `i2c.Status_reg0 [TXDV] = 0`, repeat step 3, 4 and 6 until there is no further data.
7. **Wait for completion of transfer.** Check for `i2c.Interrupt_status_reg0 [COMP] = 1`.

Example: Master Read Using Interrupt Method

1. **Set direction of transfer as read and clear the FIFO's.** Write 0×41 to `i2c.Control_reg0`.
2. **Clear interrupts.** Read and write back the read value to `i2c.Interrupt_status_reg0`.
3. **Enable Timeout, NACK, Rx overflow, Arbitration lost, DATA, Completion interrupts.** Write $0 \times 22F$ to `i2c.Intrpt_en_reg0`.

4. **Write read data count to transfer size register and hold bus if required.** Write read data count value to `i2c.Transfer_size_reg0`. If read data count greater than FIFO depth, set `i2c.Control_reg0 [HOLD]`.
5. **Write the slave address.** Write the address to the `i2c.I2C_address_reg0` register.
6. **Wait for data to be received into FIFO.**
 - a. If read data count is equal to or greater than FIFO depth, wait for `i2c.Interrupt_status_reg0 [DATA] = 1`. Read 14 bytes from FIFO. Decrement the read data count by 14 and if it is less than or equal to the FIFO depth, clear `i2c.Control_reg0[HOLD]`
 - b. Otherwise, wait for `i2c.Interrupt_status_reg0 [COMP] = 1` and read data from the FIFO based on the read data count.
7. **Check for completion of transfer.** Check if read count reaches zero. Otherwise repeat from step 6.

Example: Master Write Using Interrupt Method

1. **Set direction of transfer as write and clear the FIFO's.** Write `0x40` to `i2c.Control_reg0`.
2. **Clear Interrupts.** Read and write back the read value to `i2c.Interrupt_status_reg0`.
3. **Enable Timeout, NACK, Tx Overflow, Arbitration lost, DATA, Completion interrupts.** Write `0x24F` to the `i2c.Intrpt_en_reg0` register.
4. **Enable bus HOLD logic.** Set `i2c.Control_reg0 [HOLD]` if the write data count is greater than the FIFO depth.
5. **Calculate the space available in FIFO.** Subtract the `i2c.Transfer_size_reg0` value from the FIFO depth.
6. **Fill the data into FIFO.** Write the data to `i2c.I2C_data_reg0` based on the count obtained in step 5.
7. **Write the slave address.** Write the address to the `i2c.I2C_address_reg0` register.
8. **Wait for data to be sent.** Check for `i2c.Interrupt_status_reg0 [COMP]` to be set.
 - a. If further data is to be written, repeat steps 5, 6 and 8.
 - b. If there is no further data, set `i2c.Control_reg0 [HOLD] = 0`.
9. **Wait for completion of transfer.** Check for `i2c.Interrupt_status_reg0 [COMP]` to be set.

Example: Slave Monitor Mode

Slave monitor mode helps to monitor when the slave is in the busy state. The slave ready interrupt occurs only when slave is not busy. This can be done only in master mode:

1. **Select slave monitor mode and clear the FIFOs.** Write `0x60` to `i2c.Control_reg0`.
2. **Clear interrupts.** Read and write back the read value to `i2c.Interrupt_status_reg0`.
3. **Enable Interrupts.** Set `i2c.Intrpt_en_reg0 [SLV_RDY] = 1`.
4. **Set slave monitor delay.** Set `i2c.Slave_mon_pause_reg0` with `0xF`.
5. **Write the Slave Address.** Write the address to the `i2c.I2C_address_reg0` register.
6. **Wait for slave to be ready.** Poll on `i2c.Interrupt_status_reg0 [SLV_RDY] = 1`.

20.3.5 Register Overview

An overview of the I2C registers is provided in [Table 20-3](#).

Table 20-3: I2C Register Overview

| Function | Register Names | Overview |
|----------------------|---|--|
| Configuration | Control_reg0 | Configure the operating mode |
| Data | I2C_address_reg0 I2C_data_reg0 Transfer_size_register0 Slave_mon_pause_reg0 Time_out_reg0 Staus_reg0 | Transfer data and monitors status. |
| Interrupt Processing | Interrupt_status_reg0 Interrupt_mask_reg0 Interrupt_enable_reg0 Interrupt_disable_reg0 | Enable/disable interrupt detection, mask interrupt set to the interrupt controller, read raw interrupt status. |

20.4 System Functions

20.4.1 Clocks

The controller, I/O interface and APB interconnect are driven by CPU_1X clock. This clock comes from the PS clock subsystem.

PS Clock Subsystem

CPU_1x Clock

Refer to section [25.2 CPU Clock](#), for general clock programming information.

Operating Restrictions

The clock operating restrictions are described in section [20.1.3 Notices](#).

20.4.2 Reset Controller

The controller reset bits are generated by the PS, see [Chapter 26, Reset System](#).

Example: Controller Reset

1. **Assert Controller Reset:** Set slcr.I2C_RST_CTRL[I2Cx_CPU1X_RST] bit = 1.
2. **De-assert Controller Reset:** Clear slcr.I2C_RST_CTRL[I2Cx_CPU1X_RST] bit = 0.

20.5 I/O Interface

20.5.1 Pin Programming

The I2C SCL and SDA signals can be routed to one of many sets of MIO pins or to the EMIO interface. All of the I2C signals are listed in [Table 20-2](#). The routing of the SCL and SDA signals are described in section [2.5 PS-PL MIO-EMIO Signals and Interfaces](#).

Example: Route I2C 0 SCL and SDA Signals to MIO Pins 50, 51

In this example, the I2C 0 SCL and SDA signals are routed through MIO pins 50 and 51. Many other pin options are possible.

1. **Configure MIO pin 50 for the SCL signal.** Write `0x0000_1240` to the `slcr.MIO_PIN_50` register:
 - a. Route I2C 0 SCL signal to pin 50.
 - b. 3-state controlled by I2C (set `TRI_ENABLE = 0`).
 - c. LVCMOS18 (refer to the register definition for other voltage options).
 - d. Slow CMOS edge (benign setting).
 - e. Enable internal pull-up resistor.
 - f. Disable HSTL receiver.
2. **Configure MIO pin 51 for the SDA signal.** Write `0x0000_1240` to the `slcr.MIO_PIN_51` register:
 - a. Route I2C 0 SDA signal to pin 51.
 - b. 3-state controlled by the I2C (set `TRI_ENABLE = 0`).
 - c. LVCMOS18 (refer to the register definition for other voltage options).
 - d. Slow CMOS drive edge.
 - e. Enable internal pull-up resistor.
 - f. Disable HSTL receiver.

20.5.2 MIO-EMIO Interfaces

[Table 20-4](#) identifies the interface signals to the I2C controller. The MIO pins and any restrictions based on device version are shown in the MIO table in section [2.5.4 MIO-at-a-Glance Table](#).

Table 20-4: I2C MIO Pins and EMIO Signals

| I2C Interface | Default Controller Input Value | MIO Pins | | EMIO Signals | |
|---------------------|--------------------------------|--|-----|---------------|-----|
| | | Numbers | I/O | Name | I/O |
| I2C 0, Serial Clock | 0 | 10, 14, 18, 22, 26, 30, 34, 38, 42, 46, 50 | IO | EMIOI2C0SCLI | I |
| | | | | EMIOI2C0SCLO | O |
| | | | | EMIOI2C0SCLTN | O |

Table 20-4: I2C MIO Pins and EMIO Signals (Cont'd)

| I2C Interface | Default Controller Input Value | MIO Pins | | EMIO Signals | |
|---------------------|--------------------------------|--|-----|---------------|-----|
| | | Numbers | I/O | Name | I/O |
| I2C 0, Serial Data | ~ | 11, 15, 19, 23, 27, 31, 35, 39, 43, 47, 51 | IO | EMIOI2C0SDAI | I |
| | | | | EMIOI2C0SDAO | O |
| | | | | EMIOI2C0SDATN | O |
| I2C 1, Serial Clock | 0 | 12, 16, 20, 24, 28, 32, 36, 40, 44, 48, 52 | IO | EMIOI2C1SCLI | I |
| | | | | EMIOI2C1SCLO | O |
| | | | | EMIOI2C1SCLTN | O |
| I2C 1, Serial Data | ~ | 13, 17, 21, 25, 29, 33, 37, 41, 45, 49, 53 | IO | EMIOI2C1SDAI | I |
| | | | | EMIOI2C1SDAO | O |
| | | | | EMIOI2C1SDATN | O |

Programmable Logic Description

21.1 Introduction

The Zynq®-7000 SoC integrates a feature-rich dual/single core Arm® Cortex™-A9 MPCore™ based processing system (PS) and Xilinx programmable logic (PL) in a single device. Each Zynq-7000 device contains the same PS while the PL and I/O resources vary between the devices. The PL of the six smallest devices, the 7z010/7z015/7z020 (dual core) and the 7z007s/7z012s/7z014s (single core) is based on Artix®-7 FPGA logic. The three biggest devices, the 7z030, 7z035, 7z045, and 7z100 are based on Kintex®-7 FPGA logic. For documentation resources, refer to [DS190](#), *Zynq-7000 SoC Overview*.

The PS and PL can be tightly or loosely coupled using multiple interfaces and other signals that have a combined total of over 3,000 connections. This enables the designer to effectively integrate user-created hardware accelerators and other functions in the PL logic that are accessible to the processors and can also access memory resources in the PS. Zynq customers are able to differentiate their product in hardware by customizing their applications using PL.

The processors in the PS always boot first, allowing a software centric approach for PL configuration. The PL can be configured as part of the boot process or configured at some point in the future. Additionally, the PL can be completely reconfigured or used with partial, dynamic reconfiguration (PR). PR allows configuration of a portion of the PL. This enables optional design changes such as updating coefficients or time-multiplex the PL resources by swapping in new algorithms as needed. This latter capability is analogous to the dynamic loading and unloading of software modules. The PL configuration data is referred to as a bitstream.

The PL can be on a separate power domain from the PS. This enables users to save power by completely shutting down the PL. In this mode, the PL consumes no static or dynamic power, thus significantly reducing the power consumption of the device. The PL must be reconfigured when coming out of this mode. Users need to take into account the re-configuration time of the PL for their particular application as this varies depending on the size of the bitstream for their application.

21.1.1 Features

The PL provides a rich architecture of user-configurable capabilities. The key features are:

- Configurable logic blocks (CLB)
 - 6-input look-up tables (LUTs)
 - Memory capability within the LUT

- Register and shift register functionality
- Cascadable adders
- 36 KB block RAM
 - Dual port
 - Up to 72 bit-wide
 - Configurable as dual 18 KB
 - Programmable FIFO logic
 - Built-in error correction circuitry
- Digital signal processing – DSP48E1 Slice
 - 25 × 18 two's complement multiplier/accumulator high-resolution 48-bit multiplier/accumulator
 - Power saving 25-bit pre-adder to optimize symmetrical filter applications
 - Advanced features: optional pipelining, optional ALU, and dedicated buses for cascading
- Clock management
 - High-speed buffers and routing for low-skew clock distribution
 - Frequency synthesis and phase shifting
 - Low-jitter clock generation and jitter filtering
- Configurable I/Os
 - High-performance SelectIO technology
 - High-frequency decoupling capacitors within the package for enhanced signal integrity
 - Digitally controlled impedance that can be 3-stated for lowest power, high-speed I/O operation
 - High-range (HR) I/O supporting 1.2V to 3.3V
 - High performance (HP) I/Os support 1.2V to 1.8V (7z030, 7z035, 7z045, and 7z100 devices)
- Low-power serial transceivers (7z012s, 7z015, 7z030, 7z035, 7z045 and 7z100 devices)
 - High-performance transceivers capable of up to 12.5 Gb/s (GTX) in 7z030, 7z035, 7z045, and 7z100 devices.
 - High-performance transceivers capable of up to 6.25 Gb/s (GTP) in 7z012s and 7z015 devices.
 - Low-power mode optimized for chip-to-chip interfaces
 - Advanced transmit pre and post emphasis, and receiver linear (CTLE) and decision feedback equalization (DFE), including adaptive equalization for additional margin
- Integrated interface block for PCI Express designs
 - Compatible with the PCI Express Base Specification 2.1 with Endpoint and Root Port capability
 - Supports Gen2 (5.0 Gb/s)
 - Advanced configuration options, advanced error reporting (AER), and end-to-end CRC (ECRC) advanced error reporting and ECRC features

21.1.2 PL Resources by Device Type

The PL resources on a per-device type are summarized in [Table 21-1](#).

Table 21-1: PL Resources by Device Type

| Resource | 7z007s | 7z012s | 7z014s | 7z010 | 7z015 | 7z020 | 7z030 | 7z035 | 7z045 | 7z100 |
|---|----------------------|----------------------|-----------------------|--------------------|--------------------|--------------------|--------------------|------------------------|------------------------|---------------------|
| Logic Slices | | | | | | | | | | |
| Total | 3,600 ⁽¹⁾ | 8,600 ⁽¹⁾ | 10,150 ⁽¹⁾ | 4,400 | 11,550 | 13,300 | 19,650 | 42,975 | 54,650 | 69,350 |
| Type L | 1,100 | 5,000 | 5,800 | 2,900 | 7,950 | 8,950 | 13,000 | 25,375 | 37,050 | 42,300 |
| Type M | 1,500 | 3,600 | 4,350 | 1,500 | 3,600 | 4,350 | 6,650 | 17,600 | 17,600 | 27,050 |
| LUTs | | | | | | | | | | |
| Total | 14,400 | 34,400 | 40,600 | 17,600 | 46,200 | 53,200 | 78,600 | 171,900 | 218,600 | 277,400 |
| Flip-flops | 28,800 | 68,800 | 81,200 | 35,200 | 92,400 | 106,400 | 157,200 | 343,800 | 437,200 | 554,800 |
| Logic cells | 23,000 | 55,000 | 65,000 | 28,160 | 73,920 | 85,120 | 125,760 | 275,040 | 349,760 | 443,840 |
| LUTRAM Kb | 375 | 900 | 1,088 | 375 | 900 | 1,088 | 1,663 | 4,400 | 4,400 | 6,763 |
| SRL Kb | 188 | 450 | 544 | 188 | 450 | 544 | 831 | 2,200 | 2,200 | 3,381 |
| Memory Resources | | | | | | | | | | |
| Block RAM count | 50 ⁽²⁾ | 72 ⁽²⁾ | 107 ⁽²⁾ | 60 | 95 | 140 | 265 | 500 | 545 | 755 |
| Kb | 1,800 | 2,590 | 3,850 | 2,160 | 3,420 | 5,040 | 9,540 | 18,000 | 19,620 | 27,180 |
| KB | 220 | 320 | 480 | 240 | 380 | 560 | 1,060 | 2,250 | 2,180 | 3,020 |
| Columns per device | 5 | 5 | 6 | 5 | 5 | 6 | 8 | 9 | 9 | 12 |
| Block RAMs per column | Varies, usually 20 | Varies, usually 30 | Varies, usually 30 | Varies, usually 20 | Varies, usually 30 | Varies, usually 30 | Varies, usually 40 | Varies, usually 70 | Varies, usually 70 | Varies, usually 70 |
| Clocking | | | | | | | | | | |
| MMCM/ PLL count | 2 | 3 | 4 | 2 | 3 | 4 | 5 | 8 | 8 | 8 |
| DSPs (DSP48E1) | | | | | | | | | | |
| Count | 66 ⁽²⁾ | 120 ⁽²⁾ | 170 ⁽²⁾ | 80 | 160 | 220 | 400 | 900 | 900 | 2,020 |
| Columns per device | 4 | 4 | 5 | 4 | 4 | 5 | 6 | 7 | 7 | 15 |
| DSPs per column | Varies, usually 40 | Varies, usually 60 | Varies, usually 60 | Varies, usually 40 | Varies, usually 60 | Varies, usually 60 | Varies, usually 80 | Varies, usually 140 | Varies, usually 140 | Varies, usually 140 |
| Gigabit Transceivers⁽³⁾ | | | | | | | | | | |
| GTP | 0 | 4 | 0 | 0 | 4 | 0 | 0 | 0 | 0 | 0 |
| GTX | 0 | 0 | 0 | 0 | 0 | 0 | 4 | 8 or 16 ⁽³⁾ | 8 or 16 ⁽³⁾ | 16 |
| PCIe capable | no | yes | no | no | yes | no | yes | yes | yes | yes |
| Select I/O⁽⁴⁾ | | | | | | | | | | |
| Bank count | 2 | 3 | 4 | 2 | 3 | 4 | 5 | 8 | 8 | 8 |

Table 21-1: PL Resources by Device Type (Cont'd)

| Resource | 7z007s | 7z012s | 7z014s | 7z010 | 7z015 | 7z020 | 7z030 | 7z035 | 7z045 | 7z100 |
|----------|--------|--------|--------|-------|-------|-------|-------|-------|-------|-------|
| HR | 100 | 150 | 200 | 100 | 150 | 200 | 100 | 250 | 250 | 250 |
| HP | 100 | 150 | 200 | 000 | 150 | 200 | 100 | 250 | 250 | 250 |

Notes:

1. Number of slices corresponding to the number of flip-flops and LUTRAM supported in the device.
2. The total count is limited by tools.
3. The number of transceivers in the 7z035 and 7z045 devices depends on the package type. Refer to the Serial Transceiver Channels by Device/Package table in the *Zynq-7000 SoC Packaging Guide* ([UG865](#)) for exact counts.
4. This table shows the maximum I/Os that are available for each device type. The package size might restrict the SelectIO pin counts, refer to the *Zynq-7000 SoC Packaging Guide* ([UG865](#)).

21.1.3 Notices

XADC Analog Mixed Signal Module (AMS)

The XADC is physically located in the PL and is powered by the PL. To use the XADC module, the PL must be powered up, but the PL does not need to be configured. The XADC is explained in [Chapter 30, XADC Interface](#).

Device Configuration (DevC)

The device configuration module (with option to use AES/HMAC decryption) is physically located in the PL and is powered by the PL. To use the device configuration module, the PL must be powered up but does not need to be configured. Device configuration is explained in section [6.4 Device Boot and PL Configuration](#).

21.2 PL Components

21.2.1 CLBs, Slices, and LUTs

A CLB element contains a pair of slices, and each slice is composed of four 6-input Look Up Tables (LUTs) and eight storage elements.

- SLICE(0) - slice at the bottom of the CLB and in the left column.
- SLICE(1) - slice at the top of the CLB and in the right column.

These two slices do not have direct connections to each other, and each slice is organized as a column. Each slice in a column has an independent carry chain. The LUTs have the following features:

- Single 6 input LUT with one output, or two 5 input LUTs.
- Memory capability within the LUT.
- Register and shift register functionality.

Between 25–50% of all slices can use their LUTs as distributed 64-bit RAM, as 32-bit shift register (SRL32), or as two 16-bit shift registers (SRL16). Modern synthesis tools take advantage of these highly efficient logic, arithmetic, and memory features.

For more details on Configuration Logic Blocks, see [UG474](#), *7 Series FPGAs Configurable Logic Block User Guide*.

21.2.2 Clock Management

Some of the key highlights of the clock management architecture include:

- High-speed buffers and routing for low-skew clock distribution
- Frequency synthesis and phase shifting
- Low-jitter clock generation and jitter filtering

Each Zynq-7000 SoC device has up to eight clock management tiles (CMTs), each consisting of one mixed-mode clock manager (MMCM) and one phase-locked loop (PLL).

Mixed-Mode Clock Manager and Phase-Locked Loop

The mixed-mode clock manager (MMCM) and the phase-locked loop (PLL) share many characteristics. Both can serve as a frequency synthesizer for a wide range of frequencies and as a jitter filter for incoming clocks. At the center of both components is a voltage-controlled oscillator (VCO), which speeds up and slows down depending on the input voltage it receives from the phase frequency detector (PFD).

There are three sets of programmable frequency dividers: D, M, and O. The pre-divider D (programmable by configuration and afterwards via Dynamic Configuration Port (DRP)) reduces the input frequency and feeds one input of the traditional PLL phase/frequency comparator. The feedback divider M (programmable by configuration and afterwards via DRP) acts as a multiplier because it divides the VCO output frequency before feeding the other input of the phase comparator. The values of D and M must be chosen appropriately to keep the VCO within its specified frequency range.

The VCO has eight equally-spaced output phases (0°, 45°, 90°, 135°, 180°, 225°, 270°, and 315°). Each can be selected to drive one of the output dividers (six for the PLL, O0 to O5, and seven for the MMCM, O0 to O6), each programmable by configuration to divide by any integer from 1 to 128.

The MMCM and PLL have three input-jitter filter options: Low-bandwidth mode which has the best jitter attenuation; high-bandwidth mode, which has the best phase offset; and optimized mode, which allows the tools to find the best setting.

MMCM Additional Programmable Features

The MMCM can have a fractional counter in either the feedback path (acting as a multiplier) or in one output path. Fractional counters allow non-integer increments of 1/8 and can thus increase frequency synthesis capabilities by a factor of eight.

The MMCM can also provide fixed or dynamic phase shift in small increments that depend on the VCO frequency. At 1,600 MHz, the phase-shift timing increment is 11.2 ps.

Clock Distribution

Each Zynq-7000 SoC device provides six different types of clock lines (BUFG, BUFR, BUFIO, BUFH, BUFMR, and the high-performance clock) to address the different clocking requirements of high fanout, short propagation delay, and extremely low skew.

Global Clock Lines

In each Zynq-7000 SoC device, 32 global clock lines have the highest fanout and can reach every flip-flop clock, clock enable, and set/reset as well as many logic inputs. There are 12 global clock lines within any clock region driven by the horizontal clock buffers (BUFH). Each BUFH can be independently enabled/disabled, allowing for clocks to be turned off within a region, thereby offering fine-grain control over which clock regions consume power. Global clock lines can be driven by global clock buffers, which can also perform glitchless clock multiplexing and clock enable functions. Global clocks are often driven from the CMT, which can completely eliminate the basic clock distribution delay.

Regional Clocks

Regional clocks can drive all clock destinations in their region. A region is defined as any area that is 50 I/O and 50 CLB high and half the device wide. Zynq-7000 SoC devices have between eight and twenty-four regions. There are four regional clock tracks in every region. Each regional clock buffer can be driven from either of four clock-capable input pins, and its frequency can optionally be divided by any integer from 1 to 8.

I/O Clocks

I/O clocks are especially fast and serve only I/O logic and serializer/deserializer (SerDes) circuits, as described in [Input/Output](#).

Direct connection from the MMCM to the I/O is provided for low-jitter, high-performance interfaces.

For more details on clocking resources, see [UG472, Series FPGAs Clocking Resources User Guide](#).

21.2.3 Block RAM

Some of the key features of the block RAM include:

- Dual-port 36 KB block RAM with port widths of up to 72
- Programmable FIFO logic
- Built-in optional error correction circuitry

Every Zynq-7000 SoC device has between 60 and 465 dual-port block RAMs, each storing 36 Kb. Each block RAM has two completely independent ports that share nothing but the stored data.

Synchronous Operation

Each memory access, read or write, is controlled by the clock. All inputs, data, address, clock enables, and write enables are registered. The input address is always clocked, retaining data until the next operation. An optional output data pipeline register allows higher clock rates at the cost of an extra cycle of latency.

During a write operation, the data output can reflect either the previously stored data, the newly written data, or can remain unchanged.

Programmable Data Width

Each port can be configured as 32K × 1, 16K × 2, 8K × 4, 4K × 9 (or x8), 2K × 18 (or x16), 1K × 36 (or 32), or 512 × 72 (or x64). The two ports can have different widths without any constraints.

Each block RAM can be divided into two completely independent 18 Kb block RAMs that can each be configured to any aspect ratio from 16K × 1 to 512 × 36. Everything described previously for the full 36 Kb block RAM also applies to each of the smaller 18 Kb block RAMs.

Only in simple dual-port (SDP) mode can data widths of greater than 18 bits (18 Kb RAM) or 36 bits (36 Kb RAM) be accessed. In this mode, one port is dedicated to read operations, the other to write operations. In SDP mode, one side (read or write) can be variable, while the other is fixed to 32/36 or 64/72.

Both sides of the dual-port 36 Kb RAM can be of variable width.

Two adjacent 36 Kb block RAMs can be configured as one 64K × 1 dual-port RAM without any additional logic.

Error Detection and Correction

Each 64-bit-wide block RAM can generate, store, and utilize eight additional Hamming code bits and perform single-bit error correction and double-bit error detection (ECC) during the read process. The ECC logic can also be used when writing to or reading from external 64- to 72-bit-wide memories.

FIFO Controller

The built-in FIFO controller for single-clock (synchronous) or dual-clock (asynchronous or multirate) operation increments the internal addresses and provides four handshaking flags: full, empty, almost full, and almost empty. The almost full and almost empty flags are freely programmable. Similar to the block RAM, the FIFO width and depth are programmable, but the write and read ports always have identical width.

First word fall-through mode presents the first-written word on the data output even before the first read operation. After the first word has been read, there is no difference between this mode and the standard mode.

For more details on Block RAM, see [UG473](#), *7 Series FPGAs Memory Resources User Guide*.

21.2.4 Digital Signal Processing — DSP Slice

Some highlights of the DSP functionality include:

- 25 × 18 two's complement multiplier/accumulator high-resolution (48 bit) signal processor
- Power saving pre-adder to optimize symmetrical filter applications
- Advanced features: optional pipelining, optional ALU, and dedicated buses for cascading

DSP applications use many binary multipliers and accumulators, best implemented in dedicated DSP slices. All Zynq-7000 SoC devices have many dedicated, full custom, low-power DSP slices, combining high speed with small size while retaining system design flexibility.

Each DSP slice fundamentally consists of a dedicated 25 × 18 bit two's complement multiplier and a 48-bit accumulator. The multiplier can be dynamically bypassed, and two 48-bit inputs can feed a single-instruction-multiple-data (SIMD) arithmetic unit (dual 24-bit or quad 12-bit adder/subtractor/accumulator), or a logic unit that can generate any one of ten different logic functions of the two operands.

The DSP includes an additional pre-adder, typically used in symmetrical filters. This pre-adder improves performance in densely packed designs and reduces the DSP slice count by up to 50%. The DSP also includes a 48-bit-wide pattern detector that can be used for convergent or symmetric rounding. The pattern detector is also capable of implementing 96-bit-wide logic functions when used in conjunction with the logic unit.

The DSP slice provides extensive pipelining and extension capabilities that enhance the speed and efficiency of many applications beyond digital signal processing, such as wide dynamic bus shifters, memory address generators, wide bus multiplexers, and memory-mapped I/O register files. The accumulator can also be used as a synchronous up/down counter.

For more details on DSP slices, see [UG479, 7 Series FPGAs DSP48E1 User Guide](#).

21.3 Input/Output

21.3.1 PS-PL Interfaces

The PS-PL interface contains all the signals available to the PL designer for integrating the PL-based functions and the PS.

There are two types of interfaces between the PL and the PS:

1. Functional interfaces – available for connecting with user-designed IP blocks in the PL
 - a. AXI interconnect
 - b. Extended MIO interfaces for most of the I/O Peripherals
 - c. Interrupts
 - d. DMA flow control

- e. Clocks
 - f. Debug interfaces
2. Configuration interface – connected to fixed logic within the PL configuration block, providing PS control
 - a. PCAP
 - b. Configuration status
 - c. SEU
 - d. Program/Done/Init

For details on PS-PL interfaces refer to [Chapter 2, Signals, Interfaces, and Pins](#).

Voltage Level Shifters

All of the signals between the PS and PL pass through voltage level shifters. The programming of these level shifters is explained in section [2.4 PS-PL Voltage Level Shifter Enables](#).

21.3.2 SelectIO

Some highlights of the input/output functionality include:

- High-performance SelectIO technology with support for 1,866 Mb/s DDR3
- High-frequency decoupling capacitors within the package for enhanced signal integrity
- Digitally controlled impedance that can be 3-stated for lowest power, high-speed I/O operation

The number of I/O pins varies depending on device and package size. Each I/O is configurable and can comply with a large number of I/O standards. With the exception of the supply pins and a few dedicated configuration pins, all other PL pins have the same I/O capabilities, constrained only by certain banking rules. The SelectIO resources in Zynq-7000 SoC devices are classed as either high range (HR) or high performance (HP). The HR I/Os offer the widest range of voltage support, from 1.2V to 3.3V. The HP I/Os are optimized for highest performance operation, from 1.2V to 1.8V.

All I/O pins are organized in banks, with 50 pins per bank. Each bank has one common V_{CCO} output supply, which also powers certain input buffers. Some single-ended input buffers require an internally generated or an externally applied reference voltage (V_{REF}). There are two V_{REF} pins per bank (except configuration bank 0). A single bank can have only one V_{REF} voltage value.

Zynq-7000 SoC devices use a variety of package types to suit the needs of the user, including small form factor wire-bond packages for lowest cost; conventional, high performance flip-chip packages; and lidless flip-chip packages that balance smaller form factor with high performance. In the flip-chip packages, the silicon device is attached to the package substrate using a high-performance flip-chip process. Controlled ESR discrete decoupling capacitors are mounted on the package substrate to optimize signal integrity under simultaneous switching of outputs (SSO) conditions.

I/O Electrical Characteristics

Single-ended outputs use a conventional CMOS push/pull output structure driving High towards V_{CCO} or Low towards ground, and can be put into a high-Z state. The system designer can specify the

slew rate and the output strength. The input is always active but is usually ignored while the output is active. Each pin can optionally have a weak pull-up or a weak pull-down resistor.

Most signal pin pairs can be configured as differential input pairs or output pairs. Differential input pin pairs can optionally be terminated with a 100Ω internal resistor. All Zynq-7000 SoC devices support differential standards beyond LVDS: HT, RSDS, BLVDS, differential SSTL, and differential HSTL.

Each of the I/Os supports memory I/O standards, such as single-ended and differential HSTL as well as single-ended SSTL and differential SSTL. The SSTL I/O standard can support data rates of up to 1,866 Mb/s for DDR3 interfacing applications.

3-State Digitally Controlled Impedance and Low-Power I/O Features

The 3-state digitally controlled impedance (T_DCI) can control the output drive impedance (series termination) or can provide parallel termination of an input signal to V_{CC0} or split (Thevenin) termination to $V_{CC0}/2$. This allows users to eliminate off-chip termination for signals using T_DCI. In addition to board space savings, the termination automatically turns off when in output mode or when 3-stated, saving considerable power compared to off-chip termination. The I/Os also have low-power modes for IBUF and IDELAY to provide further power savings, especially when used to implement memory interfaces.

I/O Logic

Input and Output Delay

All inputs and outputs can be configured as either combinatorial or registered. Double data rate (DDR) is supported by all inputs and outputs. Any input and some outputs can be individually delayed by up to 32 increments of 78 ps or 52 ps each.

Such delays are implemented as IDELAY and ODELAY. The number of delay steps can be set by configuration and can also be incremented or decremented while in use. ODELAY is only available for HP Select I/O. It is not available for HR select I/Os. HP Select I/O pins are available in the 7z030, 7z035, 7z045, and 7z100 devices, refer to [Table 21-1](#).

ISERDES and OSERDES

Many applications combine high-speed, bit-serial I/O with slower parallel operation inside the device. This requires a serializer and deserializer (SerDes) inside the I/O structure. Each I/O pin possesses an 8-bit IOSERDES (ISERDES and OSERDES) capable of performing serial-to-parallel or parallel-to-serial conversions with programmable widths of 2, 3, 4, 5, 6, 7, or 8 bits. By cascading two IOSERDES from two adjacent pins (default from differential I/O), wider width conversions of 10 and 14 bits can also be supported.

The ISERDES has a special oversampling mode capable of asynchronous data recovery for applications like a 1.25 Gb/s LVDS I/O-based SGMII interface.

For more details on Select I/Os, see [UG471](#), *7 Series FPGAs SelectIO Resources User Guide*.

21.3.3 GTX Low-Power Serial Transceivers

GTX low-power serial gigabit transceivers are available in the 7z030, 7z035, 7z045, and 7z100 devices except where noted in the Serial Transceiver Channels by Device/Package table in [UG865, Zynq-7000 SoC Packaging Guide](#). The 7z030 has 0 or 4 GTX transceivers, the 7z035/7z045 has 8 or 16, and the 7z100 device has 16 GTX transceivers. Refer to the packaging guide to get the transceiver count for each package type.

The 7z012s and 7z015 devices includes 4 GTP low-power serial transceivers. The GTP transceivers are discussed in section [21.3.4 GTP Low-Power Serial Transceivers](#).

Some highlights of the GTX low-power gigabit transceivers include:

- High-performance transceivers capable of up to 12.5 Gb/s line rates with flipchip packages and up to 6.6 Gb/s with bare-die flipchip packages.
- Low-power mode optimized for chip-to-chip interfaces.
- Advanced Transmit pre and post emphasis, and receiver linear (CTLE) and decision feedback equalization (DFE), including adaptive equalization for additional margin

Ultra-fast serial data transmission to optical modules, between ICs on the same PCB, over the backplane, or over longer distances is becoming increasingly popular and important to enable customer line cards to scale to 200 Gb/s. It requires specialized dedicated on-chip circuitry and differential I/O capable of coping with the signal integrity issues at these high data rates.

The Zynq-7000 SoC devices transceiver counts range from 0 to 16 transceiver circuits. Each serial transceiver is a combined transmitter and receiver. The various Zynq-7000 serial transceivers can use a combination of ring oscillators and LC tank architecture to allow the ideal blend of flexibility and performance while enabling IP portability across the family members. Lower data rates can be achieved using logic-based oversampling of PL. The serial transmitter and receiver are independent circuits that use an advanced PLL architecture to multiply the reference frequency input by certain programmable numbers between 4 and 25 to become the bit-serial data clock. Each transceiver has a large number of user-definable features and parameters. All of these can be defined during device configuration, and many can also be modified during operation.

Transmitter

The transmitter is fundamentally a parallel-to-serial converter with a conversion ratio of 16, 20, 32, 40, 64, or 80. This allows the designer to trade-off datapath width for timing margin in high-performance designs. These transmitter outputs drive the PC board with a single-channel differential output signal. TXOUTCLK is the appropriately divided serial data clock and can be used directly to register the parallel data coming from the internal logic. The incoming parallel data is fed through an optional FIFO and has additional hardware support for the 8B/10B, 64B/66B, or 64B/67B encoding schemes to provide a sufficient number of transitions. The bit-serial output signal drives two package pins with differential signals. This output signal pair has programmable signal swing as well as programmable pre- and post-emphasis to compensate for PC board losses and other interconnect characteristics. For shorter channels, the swing can be reduced to reduce power consumption.

Receiver

The receiver is fundamentally a serial-to-parallel converter, changing the incoming bit-serial differential signal into a parallel stream of words, each 16, 20, 32, 40, 64, or 80 bits. This allows the designers to trade-off internal datapath width versus logic timing margin. The receiver takes the incoming differential data stream, feeds it through programmable linear and decision feedback equalizers (to compensate for PC board and other interconnect characteristics), and uses the reference clock input to initiate clock recognition. There is no need for a separate clock line. The data pattern uses non-return-to-zero (NRZ) encoding and optionally guarantees sufficient data transitions by using the selected encoding scheme. Parallel data is then transferred into the PL using the RXUSRCLK clock. For short channels, the transceivers offers a special low power mode (LPM) for additional power reduction.

Out-of-Band Signaling

The transceivers provide out-of-band (OOB) signaling, often used to send low-speed signals from the transmitter to the receiver while high-speed serial data transmission is not active. This is typically done when the link is in a powered-down state or has not yet been initialized. This benefits PCI Express and SATA/SAS applications.

For more details on GTX Transceivers, see [UG476](#), *7 Series FPGAs GTX Transceiver User Guide*.

Placement Information by Device/Package

This section provides position information for available device and package combinations along with the pad numbers for the signals associated with each GTX serial transceiver channel.

XC7Z30-FBG484 Package Placement Diagram

Figure 21-1 shows the placement diagram for the XC7Z30-FBG484 device.

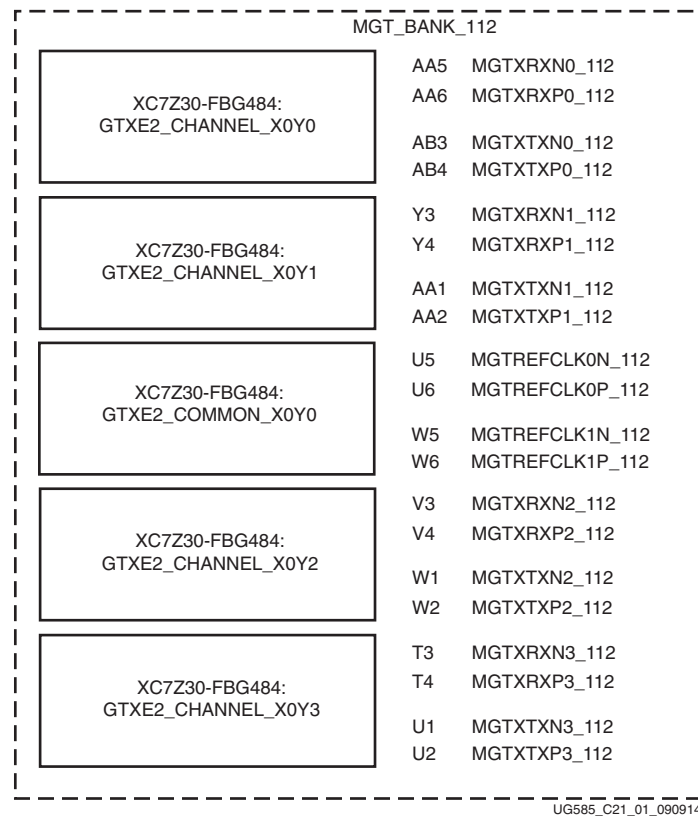

Figure 21-1: XC7Z30-FBG484 Package Placement Diagram

XC7Z30-FBG676/FFG676 Package Placement Diagram

Figure 21-2 shows the placement diagram for the XC7Z30-FBG676/FFG676 device.

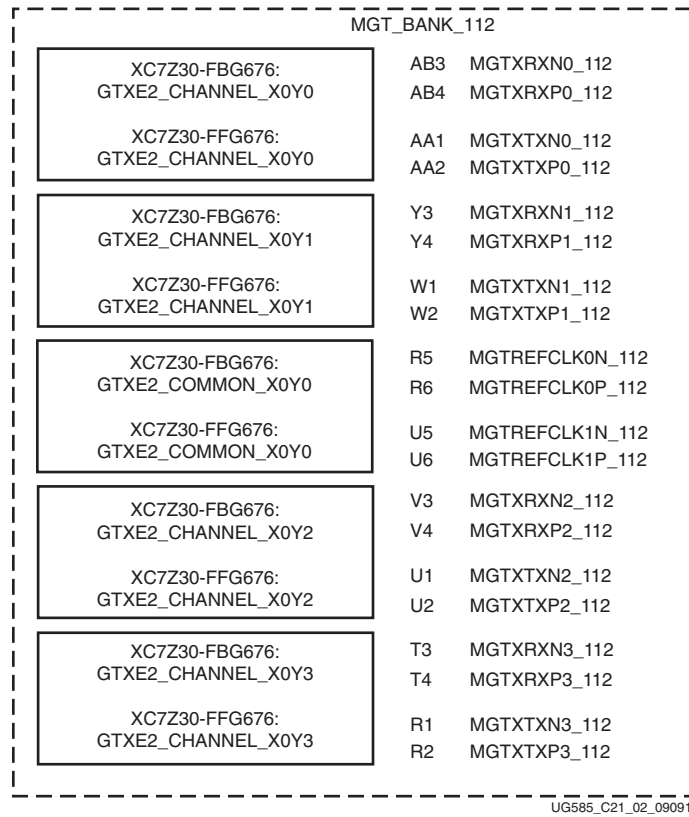

Figure 21-2: XC7Z30-FBG676/FFG676 Package Placement Diagram

XC7Z30-SBG485 Package Placement Diagram

Figure 21-3 shows the placement diagram for the XC7Z30-SBG485 device.

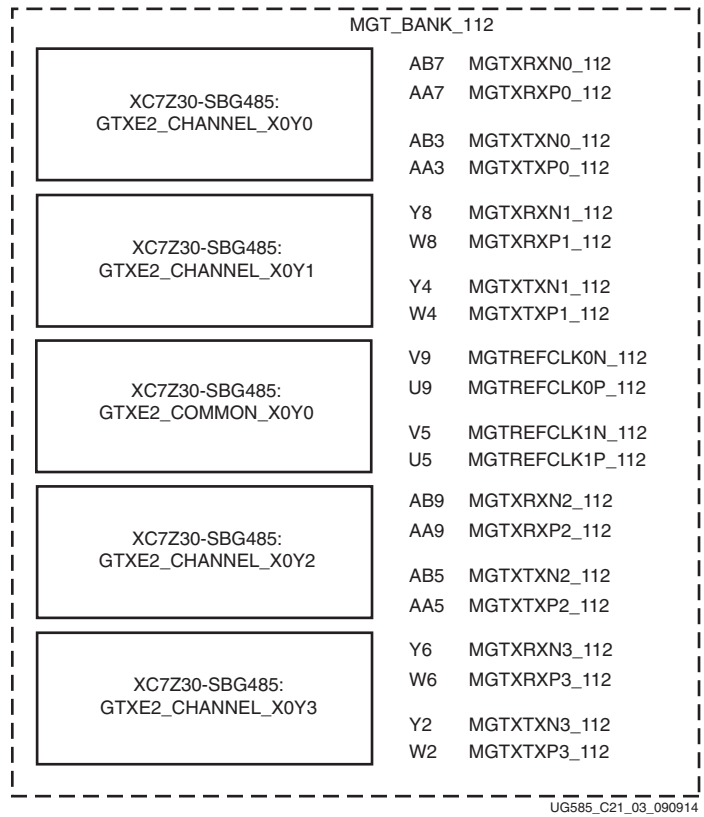

Figure 21-3: XC7Z30-SBG485 Package Placement Diagram

XC7Z35-FBG676/FFG676 and XC7Z45-FBG676/FFG676 Package Placement Diagrams

Figure 21-4 shows the placement diagrams for the XC7Z35-FBG676/FFG676 and XC7Z45-FBG676/FFG676 devices, MGT Bank 111.

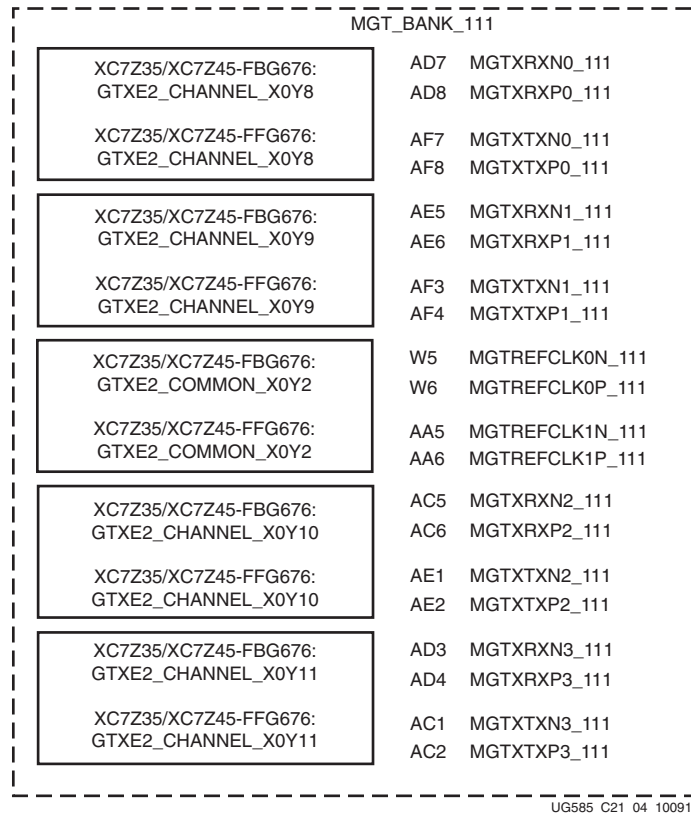

Figure 21-4: XC7Z35-FBG676/FFG676 and XC7Z45-FBG676/FFG676 MGT Bank 111 Package Placement Diagram

Figure 21-5 shows the placement diagram for the XC7Z35-FBG676/FFG676 and XC7Z45-FBG676/FFG676 devices, MGT Bank 112.

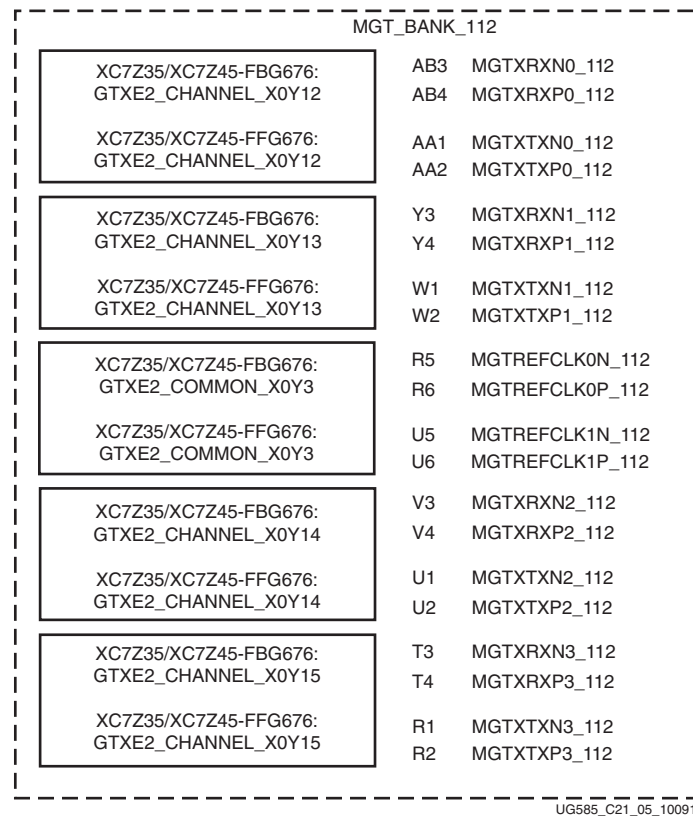

Figure 21-5: XC7Z35-FBG676/FFG676 and XC7Z45-FBG676/FFG676 MGT Bank 112 Package Placement Diagram

XC7Z35-FFG900, XC7Z45-FFG900, and XC7Z100-FFG900 Package Placement Diagram

Figure 21-6 shows the placement diagram for the XC7Z35-FFG900, XC7Z45-FFG900, and XC7Z100-FFG900 devices, MGT Bank 109.

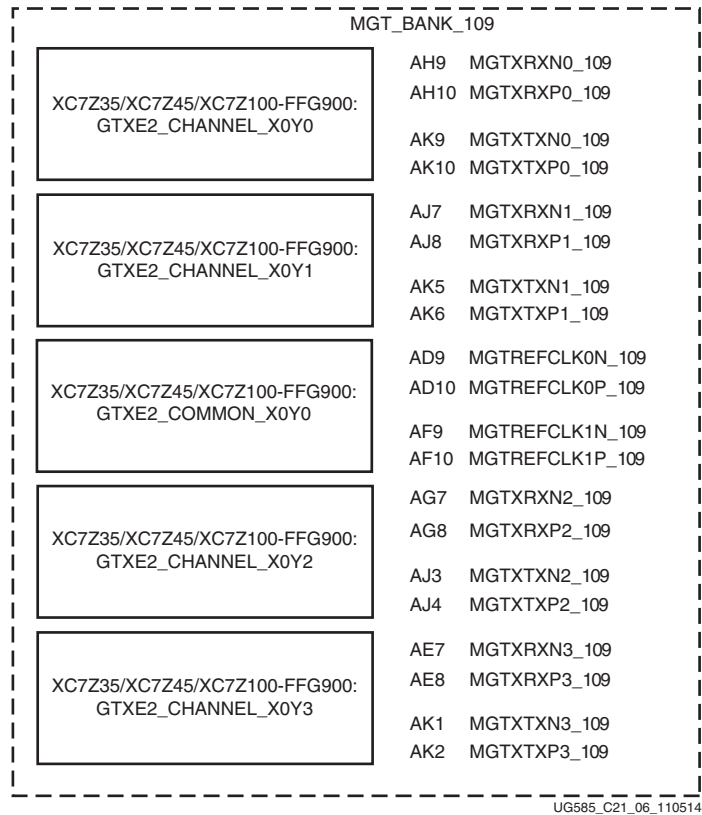

Figure 21-6: XC7Z35-FFG900, XC7Z45-FFG900, and XC7Z100-FFG900, MGT Bank 109 Package Placement Diagram

Figure 21-7 shows the placement diagram for the XC7Z35-FFG900, XC7Z45-FFG900, and XC7Z100-FFG900 devices, MGT Bank 110.

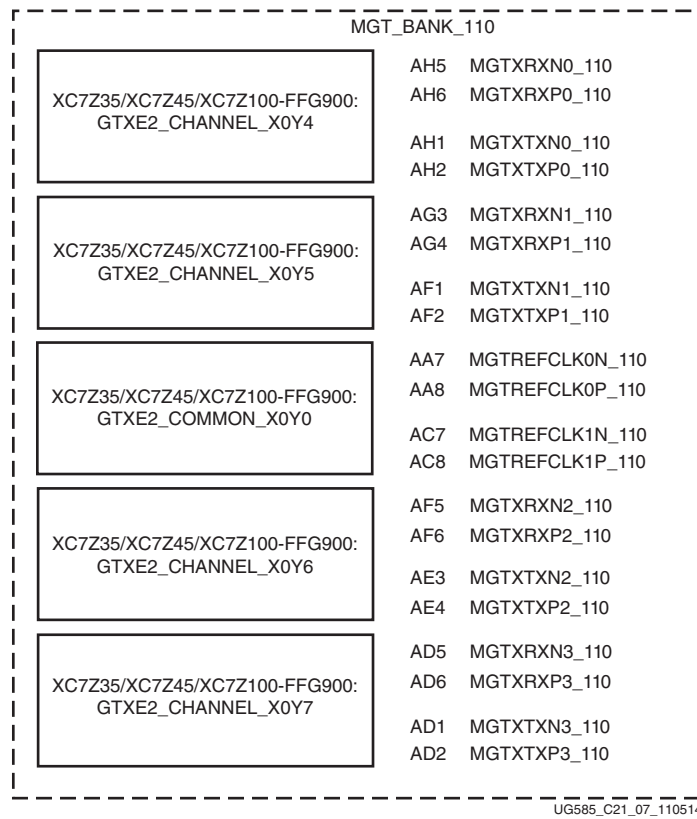

Figure 21-7: XC7Z35-FFG900, XC7Z45-FFG900, and XC7Z100-FFG900, MGT Bank 110 Package Placement Diagram

Figure 21-8 shows the placement diagram for the XC7Z35-FFG900, XC7Z45-FFG900, and XC7Z100-FFG900 devices, MGT Bank 111.

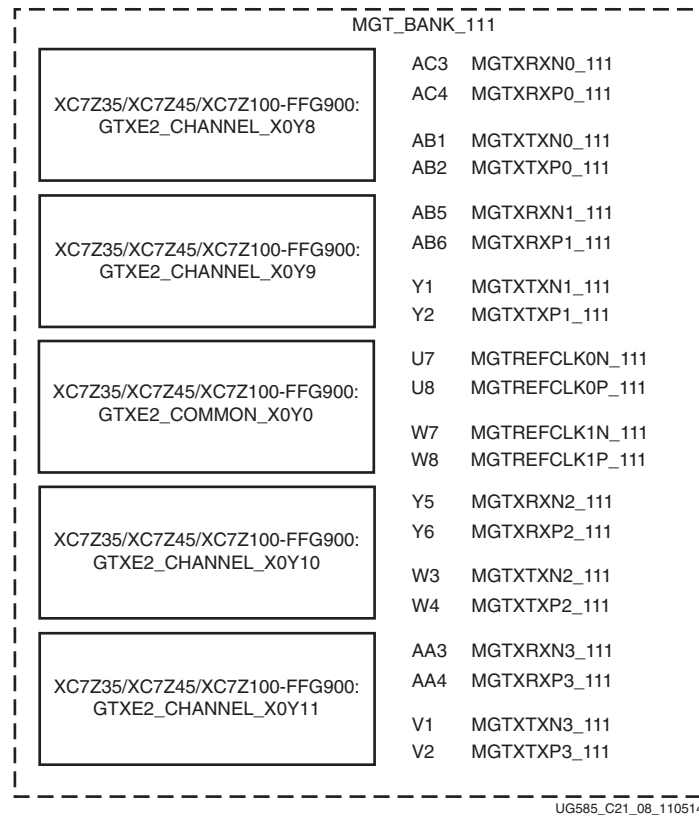

Figure 21-8: XC7Z35-FFG900, XC7Z45-FFG900, and XC7Z100-FFG900, MGT Bank 111 Package Placement Diagram

Figure 21-9 shows the placement diagram for the XC7Z35-FFG900, XC7Z45-FFG900, and XC7Z100-FFG900 devices, MGT Bank 112.

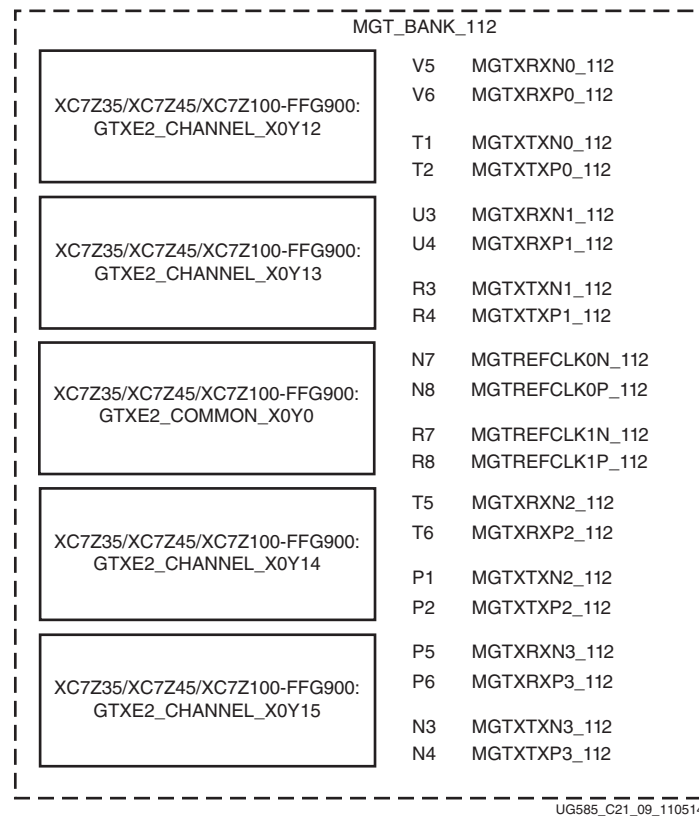

Figure 21-9: XC7Z35-FFG900, XC7Z45-FFG900, and XC7Z100-FFG900, MGT Bank 112 Package Placement Diagram

XC7Z100-FFG1156 Package Placement Diagram

Figure 21-10 shows the placement diagram for the XC7Z100-FFG1156 device, MGT Bank 109.

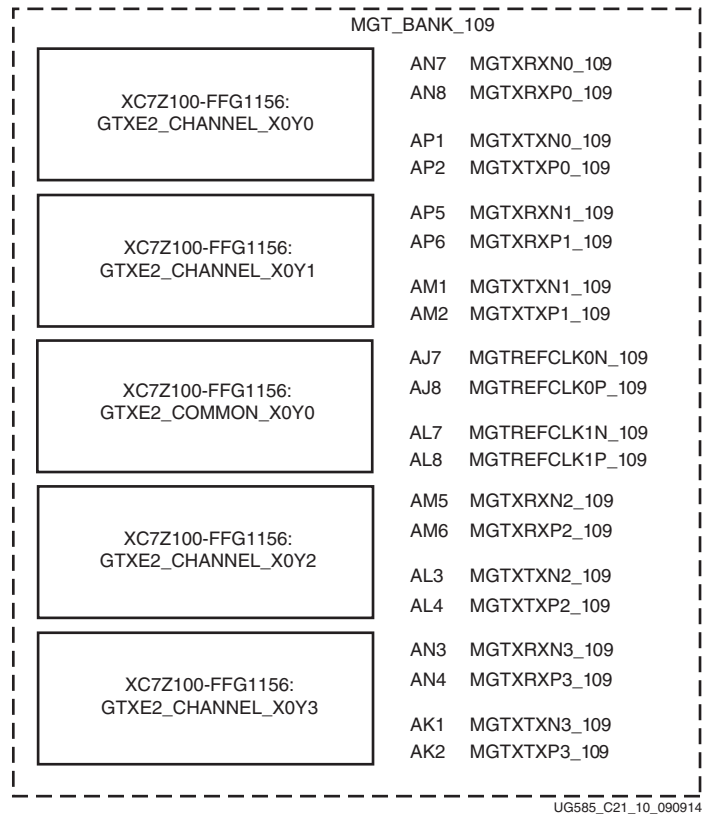

Figure 21-10: XC7Z100-FFG1156, MGT Bank 109 Package Placement Diagram

Figure 21-11 shows the placement diagram for the XC7Z100-FFG1156 device, MGT Bank 110.

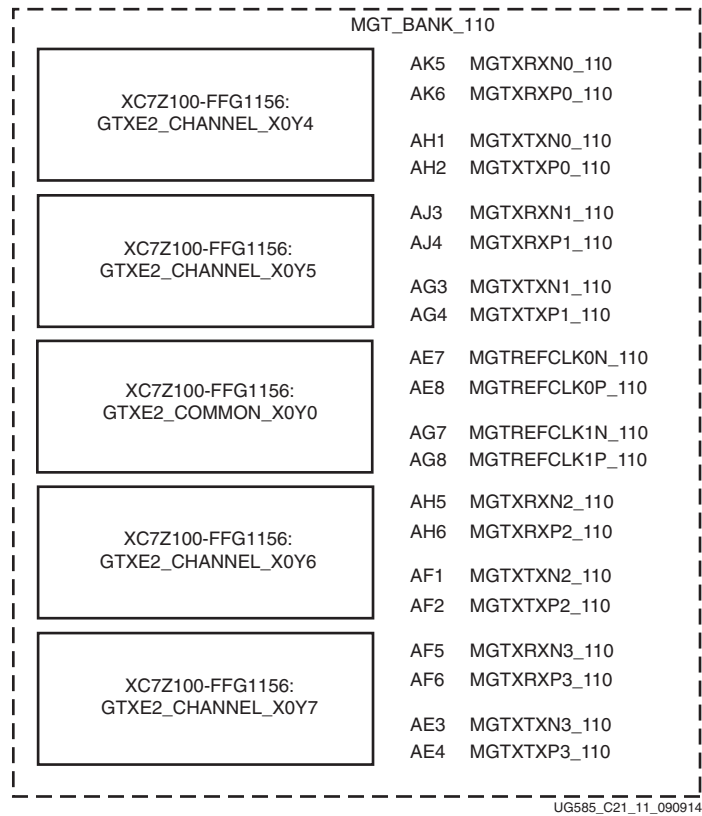

Figure 21-11: XC7Z100-FFG1156, MGT Bank 110 Package Placement Diagram

Figure 21-12 shows the placement diagram for the XC7Z100-FFG1156 device, MGT Bank 111.

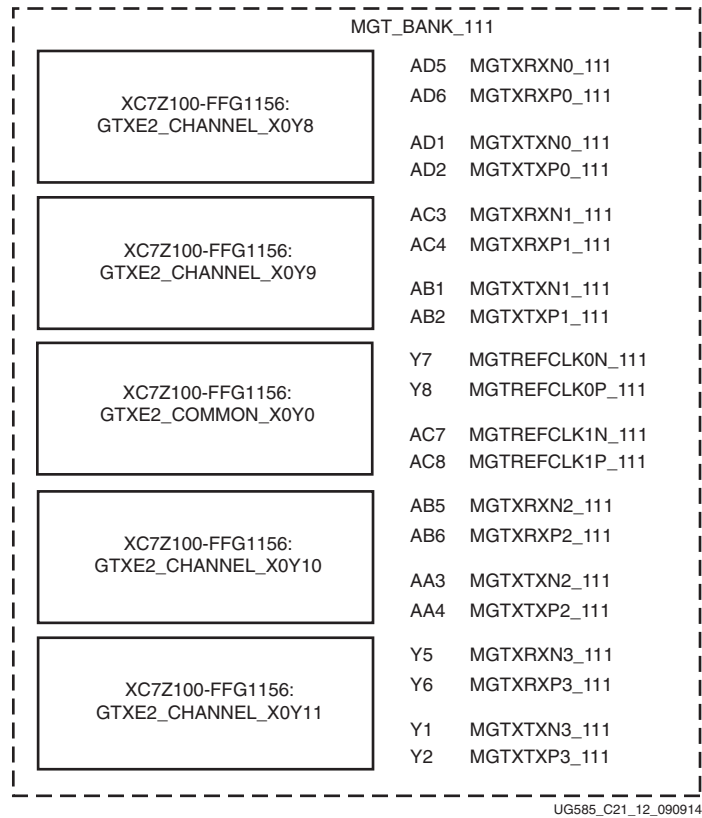

Figure 21-12: XC7Z100-FFG1156, MGT Bank 111 Package Placement Diagram

Figure 21-13 shows the placement diagram for the XC7Z100-FFG1156 device, MGT Bank 112.

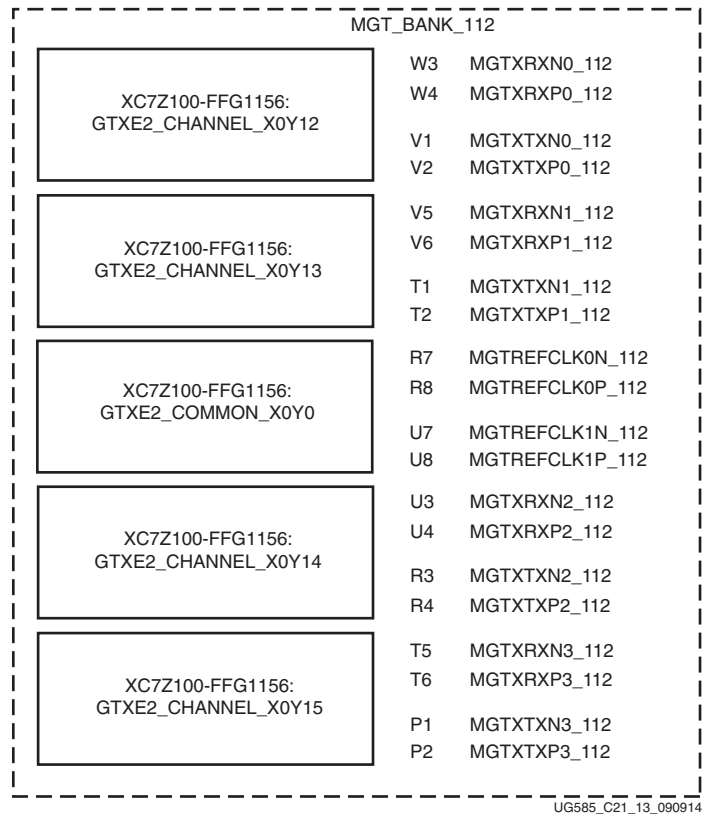

Figure 21-13: XC7Z100-FFG1156, MGT Bank 112 Package Placement Diagram

21.3.4 GTP Low-Power Serial Transceivers

The 7z012s and 7z015 devices provides four GTP low-power serial transceivers that can operate up to 6.25 Mb/s per transceiver. The GTX and the GTP transceivers are similar to each other except as noted in [UG482](#), *7 Series FPGAs GTP Transceivers User Guide*. Table 1-1 (in UG482) includes a summary of differences; the GTP transceivers include a 2-byte internal datapath (but not a 4-byte path), two shared ring oscillator PLLs, and does not include the decision feedback equalization (DFE).

Placement Information by Device/Package

This section provides position information for available device and package combinations along with the pad numbers for the signals associated with each GTP serial transceiver channel.

XC7Z012-CLG485 and XC7Z015-CLG485 Package Placement Diagram

Figure 21-14 shows the placement diagram for the XC7Z012s-CLG485 single core and XC7Z015-CLG485 dual core devices.

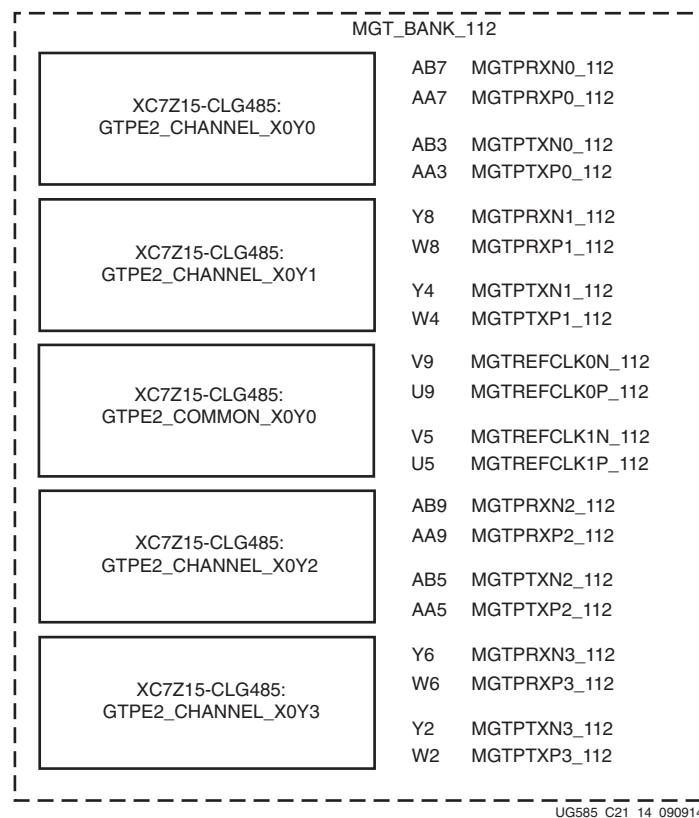

Figure 21-14: XC7Z012S-CLG485 and XC7Z015-CLG485 Package Placement Diagram

21.3.5 Integrated I/O Block for PCIe

The integrated PCI Express I/O block is only supported in the 7z012s, 7z015, 7z030, 7z035, 7z045, and 7z100 devices. Highlights of the integrated blocks for PCI Express include:

- Compatible with the PCI Express Base Specification 2.1 with Endpoint and Root Port capability
- Supports Gen1 (2.5 Gb/s) and Gen2 (5 Gb/s)
- Advanced configuration options, advanced error reporting (AER), and end-to-end CRC (ECRC) advanced error reporting and ECRC features in the integrated block depending on family

All Zynq-7000 SoC devices with transceivers include an integrated block for PCI Express technology that can be configured as an Endpoint or Root Port, compatible with the PCI Express Base Specification Revision 2.1. The Root Port can be used to build the basis for a compatible Root Complex, to allow custom communication between the Zynq-7000 SoC device and other devices via the PCI Express protocol, and to attach ASSP Endpoint devices, such as Ethernet controllers or fibre channel HBAs, to the Zynq-7000 devices.

This block is highly configurable to system design requirements and can operate 1, 2, 4, or 8 lanes at the 2.5 Gb/s and 5.0 Gb/s data rates. For high-performance applications, advanced buffering techniques of the block offer a flexible maximum payload size of up to 1,024 bytes. The integrated block interfaces to the integrated high-speed transceivers for serial connectivity and to block RAMs for data buffering. Combined, these elements implement the physical layer, data link layer, and transaction layer of the PCI Express protocol.

Xilinx provides a light-weight, configurable, easy-to-use LogiCORE™ IP wrapper that ties the various building blocks (the integrated block for PCI Express, the transceivers, block RAM, and clocking resources) into an Endpoint or Root Port solution. The system designer has control over many configurable parameters: lane width, maximum payload size, programmable logic interface speeds, reference clock frequency, and base address register decoding and filtering.

Xilinx offers AXI4 memory mapped wrapper for the integrated block. AXI4 (memory mapped) is designed for Vivado/EDK design flow and MicroBlaze™ processor based designs.

For more details on PCIe, see [PG054](#), *7 Series FPGAs Integrated Block for PCI Express LogiCORE IP Product Guide*.

21.4 Configuration

Zynq-7000 SoC device stores its customized PL configuration store their customized configuration in SRAM-type internal latches. The number of configuration bits is between 17 Mb and 140 Mb, depending on device size and user-design implementation options. The configuration storage is volatile and must be reloaded after the PL is power cycled. The PS software or the Xilinx JTAG TAP controller can reload the configuration at any time. For details about different boot and configuration modes refer to [Chapter 6, Boot and Configuration](#). Uncompressed/unencrypted PL bitstream lengths are provided in [Table 21-2](#).

Table 21-2: Uncompressed/Unencrypted PL Bitstream Lengths

| Zynq 7000 SoC Device | Length (bits) | Length, rounded up (MB) |
|----------------------------|---------------|-------------------------|
| Single Core Devices | | |
| 7z007s | 16,669,920 | 2 |
| 7z012s | 28,085,344 | 3.5 |
| 7z014s | 32,364,512 | 3.9 |
| Dual Core Devices | | |
| 7z010 | 16,669,920 | 2 |
| 7z015 | 28,085,344 | 3.5 |
| 7z020 | 32,364,512 | 3.9 |
| 7z030 | 47,839,328 | 5.8 |
| 7z035 | 106,571,232 | 12.8 |
| 7z045 | 106,571,232 | 12.8 |
| 7z100 | 139,330,784 | 16.7 |

In all devices, the PL bitstream, which contains sensitive customer IP, can be protected with 256-bit AES encryption and HMAC/SHA-256 authentication to prevent unauthorized copying of the design. The PL performs decryption on the fly during configuration using an internally stored 256-bit key. This key can reside in battery-backed RAM or in nonvolatile eFUSE bits.

Most configuration data can be read back without affecting the system's operation. Typically, configuration is an all-or-nothing operation, the device also supports partial reconfiguration. This is an extremely powerful and flexible feature that allows the user to change portions of the logic in the PL while other portions remain static. Users can time-slice these portions to fit more IP into smaller devices, saving cost and power. Where applicable in certain designs, partial reconfiguration can greatly improve the versatility of the Zynq-7000 SoC device.

Programmable Logic Design Guide

22.1 Introduction

This chapter covers the following topics:

- [Programmable Logic for Software Offload](#) is intended to introduce the user to high-level concepts of using the Programmable Logic (PL) to offload CPU functions.
- [PL and Memory System Performance Overview](#) discusses various performance-related behaviors of memory paths through the PS.
- [Choosing a Programmable Logic Interface](#) contrasts different PL interfaces available and shows typical uses.

22.2 Programmable Logic for Software Offload

Zynq devices have the unique capability of mapping software algorithms directly to programmable logic. Benefits might include reduced execution time, reduced operating power per function, reduced memory traffic and predictable low latency.

This section describes these benefits from a general perspective. Later sections describe specific performance and potential programmable logic topologies.

22.2.1 Benefits of Using PL to Implement Software Algorithms

Performance

Algorithms implemented in programmable logic can often be scaled to a full parallel implementation delivering maximum throughput, or to an intermediate throughput level at lower area cost. This allows the performance of an algorithm to be scaled well beyond what is achievable on the A9 or NEON units.

For example, consider an algorithm which requires 100 basic operations roughly equivalent to 100 instructions or lines of C code on the A9. A fully parallel programmable logic implementation might implement these operations using CLBs, DSP slices, and block RAMs. If the PL executes these 100 operations in parallel and is clocked at $\frac{1}{4}$ the rate of the Arm clock, this function would have a potential speedup of 25x. This assumes that the PL implementation is not limited by I/O or resources.

Power

An additional benefit of moving operations to the programmable logic is a reduction in power. Depending on the operations, programmable logic can reduce power per OP by 10-100x. Thus it might be useful to implement algorithms in the PL solely to reduce system power.

One issue to be aware of is that if the algorithm requires access to external memory, the energy cost of accessing the external memory could dominate the energy budget making a reduction in the operation power irrelevant.

Latency

Parallel logic in the PL has a low predictable delay, and cannot be interrupted. For this reason algorithms which are used to respond to real time events originating in the PL might best be serviced by algorithms in the programmable logic. This approach can reduce response time from thousands of clocks to tens of clocks.

22.2.2 Designing PL Accelerators

Programmable logic accelerators are typically created in the RTL languages Verilog or VHDL. Experienced RTL engineers can use C-code as a golden model to create an efficient hardware implementation of the algorithm in programmable logic.

For software programmers who are more comfortable with the C language, C-to-Gates compilers exist which can allow a user to build HW accelerators using the C language. Keeping in mind that C is a sequential language, automated compiler methods can be used to map the sequential code to parallel hardware without user intervention.

For instance, a FOR loop such as `for (i=0; i<10; i++) { x[i]=a[i]+b[i]; }` can be unrolled to create 10 individual adders all operating in parallel.

For video and DSP algorithms, tools such as Matlab Simulink and Xilinx System Generator can be used to directly create logic from algorithmic flowgraphs. A primary advantage of using Matlab Simulink is the rich library of functions which can be used to model, simulate and verify the hardware implementation.

Dataflow

Regardless of how an accelerator or offload engine is designed, once implemented it requires efficient dataflow to and from the accelerator. In many cases, scheduling the dataflow between the accelerator and DRAM can be more of a design challenge than implementing the actual algorithm. The word dataflow is used to reference the motion of data between system memories and PL functional units using AXI interconnect and local interconnect.

22.2.3 PL Acceleration Limits

The achievable speedup of an accelerator can be limited by I/O, resource, and latency requirements.

I/O Rate Limits

A key observation is that processing cannot proceed faster than the speed of the data transfers to and from the functional unit. For functions with a high ratio of operations to I/O the data rates are not a limiting factor, however for operations with a low ratio of operations to I/O, dataflow limits the maximum performance attainable.

For example, assume 12 bytes of input data is being read from DDR and 4 bytes of results are written back to DDR. DDR3 at 32-bits, 1,066 Mb/s and 75% utilization is limited to roughly 3,200 Mb/s. If 16 bytes are required per operation, the dataflow limits the performance to 3,200/16, or 200M function/sec. Note that this is independent of the complexity of the function. Even a simple 3 input adder is limited by the DDR bandwidth to 200M operations/sec and is not likely to be faster than an Arm A9 CPU. If however, the function consists of several thousands of operations all of which can proceed in parallel, or in a pipelined fashion, then the PL can often achieve speedups of a 10-100x.

Resource Limits

While potential speedup can be quite high, the amount of logic in the PL can limit the achievable speedup. For instance, an application which requires 100 DSP slices to achieve a speedup of 24x might be limited to a 12x speedup if only 50 DSP slices are available.

Latency Limits

The examples above assume that the PL can effectively proceed without intervention by the Arm processor. This is the case in situations where the PL implements a predetermined algorithm and dataflow using pre-allocated buffers and data is not resident in caches. In cases where the processor is creating data for the PL accelerator, additional CPU tasks might be required before the PL can begin working on the data. The CPU might need to allocate buffers and pass physical buffer addresses to the PL, or data might be flushed from cache to DDR or OCM or signal the PL to start processing. These additional steps add delays (called latency) to the total processing time. If these delays are significant, the potential acceleration is reduced. Typically it takes 100-200 clocks for the Arm processor to write a few words of data to a PL function. In general, CPU to PL calling latency is not a significant impact for applications processing more than 4 KB of data.

22.2.4 Power Offload

The PL can be used to implement individual functions at lower energy cost than when executed on the Arm A9 application processors. Less energy per operation is required because when a function is implemented in the PL, data is transferred from operator to operator in a local assembly line fashion using short, low capacitance local connections.

The same function implemented on a processor requires an instruction and data fetch from local caches or external memory and a result to be written back to registers or the memory system over longer, higher capacitance interfaces. When functions require data to be stored in memory, block

RAM can be used at lower energy cost than processor caches. Table 22-1 summarizes the approximate energy cost for various functions implemented on both the A9 processor and the 7 series programmable logic.

Table 22-1: Estimated Energy Costs for Common Operations

| Operation | PL Resource | Arm A9 Resource | PL energy/OP (pico Joules op mW/GOP/sec) |
|--------------------------------|-------------|-----------------|--|
| Logical Op of 2 var | LUT/FF | ALU | 1.3 |
| 32-bit ADD | LUT/FF | ALU | 1.3 |
| 16x16 Mult | DSP | ALU | 8.0 |
| 32-bit Read/Write register | LUTRAM | L1 | 1.4 |
| 32-bit Read/Write AXI register | LUT/FF | AXI | 30 |
| 32-bit Read/Write local RAM | BRAM | L2 | 23.7/17.2 |
| 32-bit Read/Write OCM | AXI/OCM | CPU/OCM | 44 |
| 32-bit Read/Write DDR3 | AXI/DDR | CPU/DDR | 541/211 |

Notes:

1. PL Energy costs for custom programmable logic functions are estimated using the Xilinx XPE power estimator http://www.xilinx.com/ise/power_tools/license_7series.htm.

Typically, the energy cost to read or write external DDR memory is roughly the same and much larger than the operation cost. As a consequence the energy required by functions which require even a small percentage of external access is dominated by the energy cost of the external access and the total cost will be the same in both PL and CPU implementations. Thus a key to minimizing energy cost is to localize data movement to the PL. If space allows, rather than storing data structures off chip, store them in OCM, BRAM, LUTRAM or flip-flops and avoid the use of unnecessary storage. This approach might require code to be restructured to avoid the use of unnecessary buffers.

22.2.5 Real Time Offload

The Arm A9 CPUs are optimized for application processing rather than real-time response and are often running an operating system such as Linux. The PL can be used augment the A9s with excellent real time response.

MicroBlaze Assisted Real Time Processing

One or more MicroBlaze processors can be used to as microcontrollers to manage realtime events. MicroBlaze offers excellent real-time response and can be dedicated to particular tasks. MicroBlaze controllers can typically use a few block RAMs, approximately 2,000 LUTs, and run at 100-200 MHz. Interrupt response times are in the 10s of clocks. Alternately the MicroBlaze can poll for events which can be serviced in just a few clocks. Code can be written in C or for ultimate real time control in assembly. Unlike the Cortex-A9 CPUs, MicroBlaze has a fixed execution pipeline and offers predictable response times. For many applications a PicoBlaze processor might be adequate and uses just a few hundred LUTs.

PL Interrupt Servicing

PS interrupts are routed to the PL and can be serviced by a MicroBlaze processor or by hardware state machines.

HW State Machines

When programmable response times from a MicroBlaze or PicoBlaze CPU are not sufficient, hardware state machines can be created to respond to events. These state machines are generally created in RTL, but can also be generated using MATLAB Simulink and Labview graphical design languages.

22.2.6 Reconfigurable Computing

The programmable logic in each Zynq device can be reconfigured as needed to provide new hardware accelerators. Either the entire device can be reconfigured, or a selected portion of the PL can be reconfigured. This allows for a library of accelerator functions to be stored on disk, flash memory, or DRAM and downloaded on demand. The PS can be used to orchestrate this reconfiguration over the PCAP interface and manage the allocation of PL resources.

Programmable Engines

Typically programmable logic based accelerators implement a specific data flow graph which directly converts input data to output data. An example would be a matrix multiply which pushes data from an input buffer through an array of multipliers and adders and stores the result in a result buffer. An alternative approach might be to build a programmable engine with multipliers and adder instructions to implement the algorithms and general purpose memories to store the data.

While not generally as efficient as fixed function flowgraphs, programmable engines have the advantage of being reprogrammable to implement alternate algorithms. An additional advantage is that they can be used to implement complex functions as the number of operations is limited only by the instruction memory or the bandwidth required to fetch instructions from DRAM. Also a programmable engine might more easily match the required computational rate than a fixed function flowgraph. In general, programmable engines require access to local memories for code and data storage and can require significantly more memory than fixed function flowgraphs as well as additional logic for address generation and instruction decoding.

OpenCL has been used as a programming language for these types of engines, but assembly code is also viable. These engines are an area of active research and some IP is now commercially available.

22.3 PL and Memory System Performance Overview

This section provides a comparison of various performance-related behaviors of memory paths through the PS. It is intended to familiarize the designer with the performance-related behaviors of the PL and PS memory system.

22.3.1 Theoretical Bandwidth

Table 22-2 and Table 22-3 provide a basic introduction of relative performance capabilities between various programmable interfaces, DMA, and memory controllers. The bandwidth are calculated as the interface width multiplied by a typical clock rate, not including any protocol overhead.

Table 22-2: Theoretical Bandwidth of PS-PL and PS Memory Interfaces

| Interface | Type | Bus Width (bits) | IF Clock (MHz) | Read Bandwidth (MB/s) | Write Bandwidth (MB/s) | R+W Bandwidth (MB/s) | Number of Interfaces | Total Bandwidth (MB/s) |
|-------------------------------|-----------------|------------------|----------------|-----------------------|------------------------|----------------------|----------------------|------------------------|
| General Purpose AXI | PS Slave | 32 | 150 | 600 | 600 | 1,200 | 2 | 2,400 |
| General Purpose AXI | PS Master | 32 | 150 | 600 | 600 | 1,200 | 2 | 2,400 |
| High Performance (AFI) AXI_HP | PS Slave | 64 | 150 | 1,200 | 1,200 | 2,400 | 4 | 9,600 |
| AXI_ACP | PS Slave | 64 | 150 | 1,200 | 1,200 | 2,400 | 1 | 2,400 |
| DDR | External Memory | 32 | 1,066 | 4,264 | 4,264 | 4,264 | 1 | 4,264 |
| OCM | Internal Memory | 64 | 222 | 1,779 | 1,779 | 3,557 | 1 | 3,557 |

Table 22-3: Theoretical Bandwidth of PS DMA Controllers

| DMA | Type | IF Width (Bits) | IF Clock (MHz) | Read BW (MB/s) | Write BW (MB/s) | R+W BW (MB/s) | Number of Interfaces | Total Bandwidth (MB/s) |
|------------------|-----------|-----------------|----------------|----------------|-----------------|---------------|----------------------|------------------------|
| DMAC | Arm PL310 | 64 | 222 | 1,776 | 1,776 | 3,552 | 1 | 3,552 |
| Gigabit Ethernet | PS Master | 4 | 250 | 125 | 125 | 250 | 2 | 500 |
| USB | PS Master | 8 | 60 | 60 | 60 | 60 | 2 | 120 |
| SD | PS Master | 4 | 50 | 25 | 25 | 25 | 2 | 50 |

Table 22-4: Theoretical Bandwidth of PS Interconnect

| Interconnect | Clock Domain | IF Width (Bits) | IF Clock (MHz) | Read BW (MB/S) | Read BW (MB/S) | R+W BW (MB/s) |
|----------------------|--------------|-----------------|----------------|----------------|----------------|---------------|
| Central Interconnect | CPU_2x | 64 | 222 | 1,776 | 1,776 | 3,552 |
| Masters | CPU_1x | 32 | 111 | 444 | 444 | 888 |
| Slaves | CPU_1x | 32 | 111 | 444 | 444 | 888 |
| Master Interconnect | CPU_2x | 32 | 222 | 888 | 888 | 1,776 |
| Slave Interconnect | CPU_2x | 32 | 222 | 888 | 888 | 1,776 |
| Memory Interconnect | DDR_2x | 64 | 355 | 2,840 | 2,840 | 5,680 |

A few performance insights can be inferred from these relative throughputs.

- The OCM or DDR memories are not able to be fully utilized by a single master, except if a low DDR clock rate is used. For example, DDR read bandwidth is limited to 2,840 MB/s on a particular port by the memory interconnect.
- The interconnect generally provides enough bandwidth to sustain access to the memory devices.

22.3.2 DDR Efficiency

One design consideration when using the PL to access external memory is the total amount of DDR memory bandwidth that is available. One useful metric of DDR bandwidth is the efficiency of the controller. Efficiency is the total data passed through the controller versus its theoretical throughput during a test period. Table 22-5 and Table 22-6 lists the efficiency the DDR controller under various access types. The system is configured according to Table 22-7.

Table 22-5: DDR Efficiency (System #1, 4 HP/AFI masters, AXI Burst Length of 16)

| Access Type | Address Pattern | Efficiency (%) |
|------------------|-----------------|----------------|
| Reads | Sequential | 97 |
| Reads | Random | 92 |
| Writes | Sequential | 90 |
| Writes | Random | 87 |
| Reads and Writes | Sequential | 87 |
| Reads and Writes | Random | 79 |

From a design planning perspective, accesses tested in Table 22-5 could be described as optimistic to near-typical values. The random read/write pattern is not worst case as the DDR controller optimization features are still able to improve efficiency; there might be other more pessimistic access patterns. Overall, the DDR controller was designed to have a maximum efficiency of approximately 75%.

Table 22-6 lists a DDR efficiency versus burst length example. It illustrates that moderate length bursts do not result in significant DDR efficiency loss. These moderate burst lengths can be useful in latency-sensitive environments where longer bursts can increase latency for higher-priority masters in the system.

Table 22-6: DDR Efficiency versus AXI Burst Length (System #1, 4 HP/AFI masters, Sequential Read/Writes)

| Burst Length | DDR Efficiency (%) |
|--------------|--------------------|
| 4 | 87 |
| 8 | 87 |
| 16 | 87 |

Table 22-7: Latency Example Measurement Systems

| System | PL AXI Clock (MHz) | CPU_6x4x (MHz) | CPU_2x (MHz) | DDR_3x (MHz) | DDR_2x (MHz) | DRAM | DRAM (Mb/s) |
|--------|--------------------|----------------|--------------|--------------|--------------|------|-------------|
| #1 | 150 | 675 | 225 | 525 | 350 | DDR3 | 1,050 |

22.3.3 OCM Efficiency

A similar efficiency test to the DDR example above using four high-performance ports to OCM show a maximum efficiency of 80%.

22.3.4 Interconnect Throughput Bottlenecks

At typical high-performance clock ratios, the PS interconnect is not typically the limiting factor in a high-performance system. One exception to this is when using two high-performance (HP/AFI) ports to DDR. Since ports 0/1 and 2/3 are arbitrated before the DDR controller, it is beneficial in the two port case to use one port each from these pairs, such as port 0 and 2.

22.4 Choosing a Programmable Logic Interface

This section discusses various options to connecting Programmable Logic (PL) to the Processing System (PS). The main emphasis is on data movement tasks such as direct memory access (DMA).

22.4.1 PL Interface Comparison Summary

Table 22-8 presents a qualitative overview of data transfer use cases. The estimated throughput column reflects suggested maximum throughput in a single direction (read/write).

Table 22-8: Data Movement Method Comparison Summary

| Method | Benefits | Drawbacks | Suggested Uses | Estimated Throughput |
|--------------------|--|---|---|----------------------------|
| CPU Programmed I/O | <ul style="list-style-type: none"> • Simple Software • Least PL Resources • Simple PL Slaves | <ul style="list-style-type: none"> • Lowest Throughput | <ul style="list-style-type: none"> • Control Functions | <25 MB/s |
| PS DMAC | <ul style="list-style-type: none"> • Least PL Resources • Medium Throughput • Multiple Channels • Simple PL Slaves | <ul style="list-style-type: none"> • Somewhat complex DMA programming | <ul style="list-style-type: none"> • Limited PL Resource DMAs | 600 MB/s |
| PL AXI_HP DMA | <ul style="list-style-type: none"> • Highest Throughput • Multiple Interfaces • Command/Data FIFOs | <ul style="list-style-type: none"> • OCM/DDR access only • More complex PL Master design | <ul style="list-style-type: none"> • High Performance DMA for large datasets | 1,200 MB/s (per interface) |
| PL AXI_ACP DMA | <ul style="list-style-type: none"> • Highest Throughput • Lowest Latency • Optional Cache Coherency | <ul style="list-style-type: none"> • Large burst might cause cache thrashing • Shares CPU Interconnect bandwidth • More complex PL Master design | <ul style="list-style-type: none"> • High Performance DMA for smaller, coherent datasets • Medium granularity CPU offload | 1,200 MB/s |
| PL AXI_GP DMA | <ul style="list-style-type: none"> • Medium Throughput | <ul style="list-style-type: none"> • More complex PL Master design | <ul style="list-style-type: none"> • PL to PS Control Functions • PS I/O Peripheral Access | 600 MB/s |

22.4.2 Cortex-A9 CPU via General Purpose Masters

The least intrusive method from a software perspective is to use the Cortex-A9 to move data between the PS and PL (see Figure 22-1). Data flow is directly moved by a CPU, removing the need to handle events from a separate DMA. Access to the PL is provided through the two M_AXI_GP master ports, which each have a memory address range to originate PL AXI transactions. The PL design is also simplified since as little as a single AXI slave can be implemented to service the CPU requests.

Drawbacks of using a CPU to move data is that a sophisticated CPU is spending cycles performing simple data movement instead of complex control and computation tasks, and the limited throughput available. Transfer rates less than 25 MB/s are reasonable with this method.

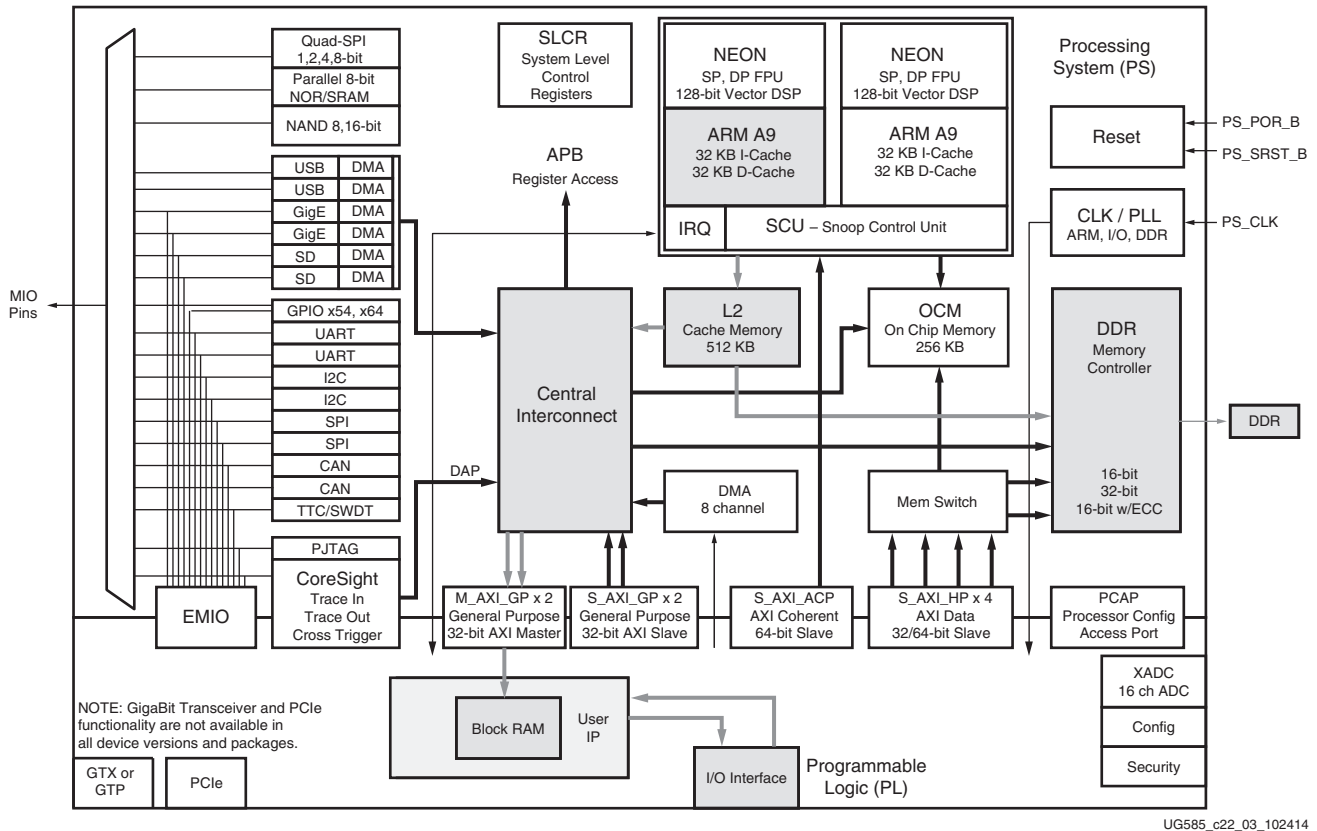

Figure 22-1: Example Cortex-A9 PL Data Movement Topology

22.4.3 PS DMA Controller (DMAC) via General Purpose Masters

The PS DMA controller (DMAC) provides a flexible DMA engine that can provide moderate levels of throughput with little PL logic resource usage (see Figure 22-2). The DMAC resides in the PS and must be programmed via DMA instructions residing in memory, typically prepared by a CPU. With support for up to eight channels, multiple DMA fabric cores can potentially be served in the single DMAC. However, the flexible programmable model might increase software complexity relative to CPU transfer or specialized PL DMA.

The DMAC interface to the PL is through the general purpose AXI master interfaces, whose 32-bit width along with the centralized DMA nature (a read and write transaction for each movement) of the DMAC to limit the DMAC from highest throughput. A peripheral request interface also allows PL slaves to provide status to the DMAC on buffer state, to prevent transactions involving a stalled PL peripheral from unnecessarily also stalling interconnect and DMAC bandwidth.

See Chapter 9, DMA Controller for more information on the DMAC controller. More information on the M_AXI_GP interfaces can be found in Chapter 5, Interconnect.

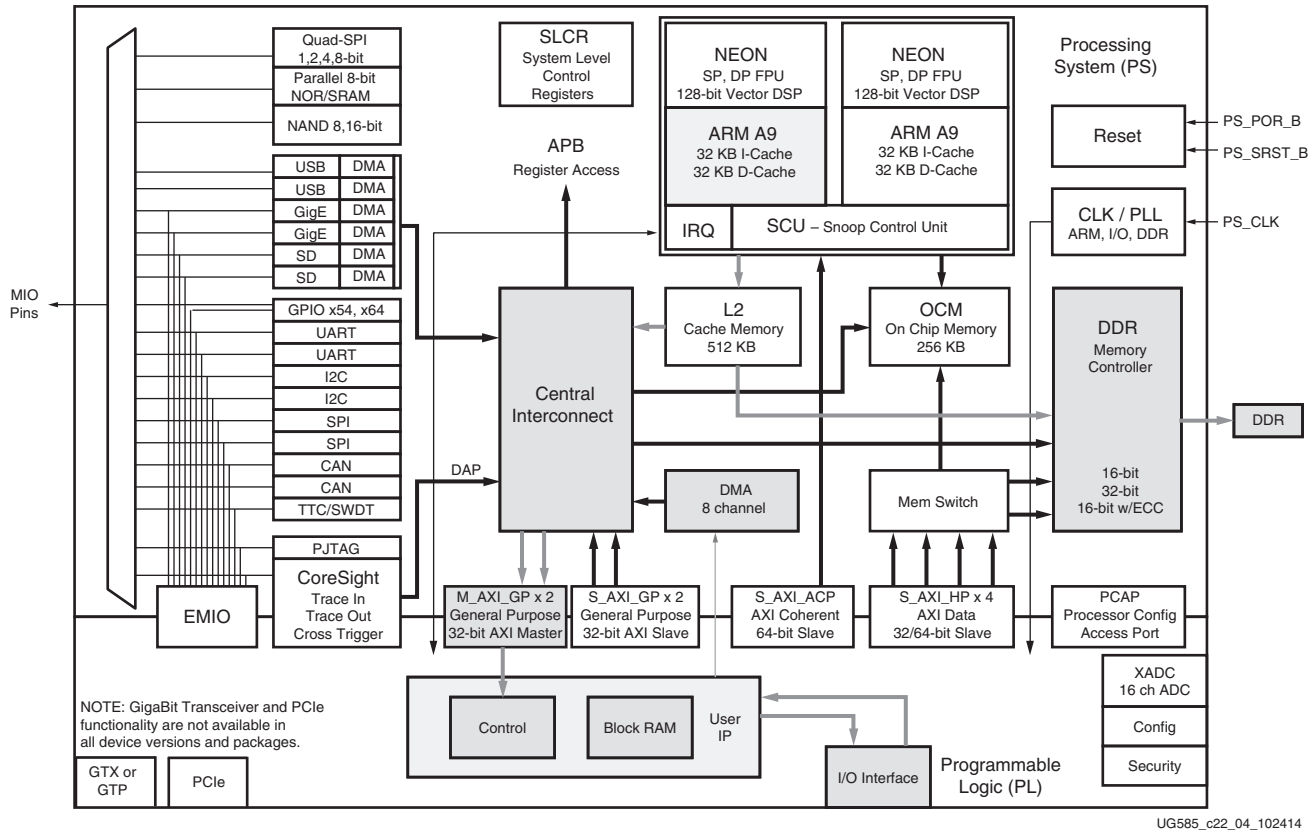

Figure 22-2: Example DMAC DMA Topology

22.4.4 PL DMA via AXI High-Performance (HP) Interface

The high-performance (S_AXI_HP) PL interfaces provide high-bandwidth PL slave interfaces to OCM and DDR memories. The AXI_HP ports are unable to access any other slaves. With four, 64-bit wide interfaces, the AXI_HP provide the greatest aggregate interface bandwidth. The multiple interfaces also save PL resources by reducing the need to a PL AXI interconnect. Each AXI_HP contains control and data FIFOs to provide buffering of transactions for larger sets of bursts, making it ideal for workloads such as video frame buffering in DDR. This additional logic and arbitration does result in higher minimum latency than other interfaces.

The user IP logic residing in the PL will generally consist of a low-speed control interface and higher performance burst interface, as shown in Figure 22-3. If control flow is orchestrated by the Cortex-A9 CPU, the general purpose M_AXI_GP port can be used for tasks such as configuring the memory addresses the User IP should access and transaction status. Transaction status can also be conveyed via PL to PS interrupts. Higher performance devices connected to AXI_HP should be able to issue multiple outstanding transactions to take advantage of the AXI_HP FIFOs.

The PL design complexity of multiple AXI interfaces along with the associated PL utilization are the primary drawbacks of implementing a DMA engine in the PL for both S_AXI_HP and S_AXI_ACP interfaces.

See Chapter 5, Interconnect for more information on the AXI_HP interface.

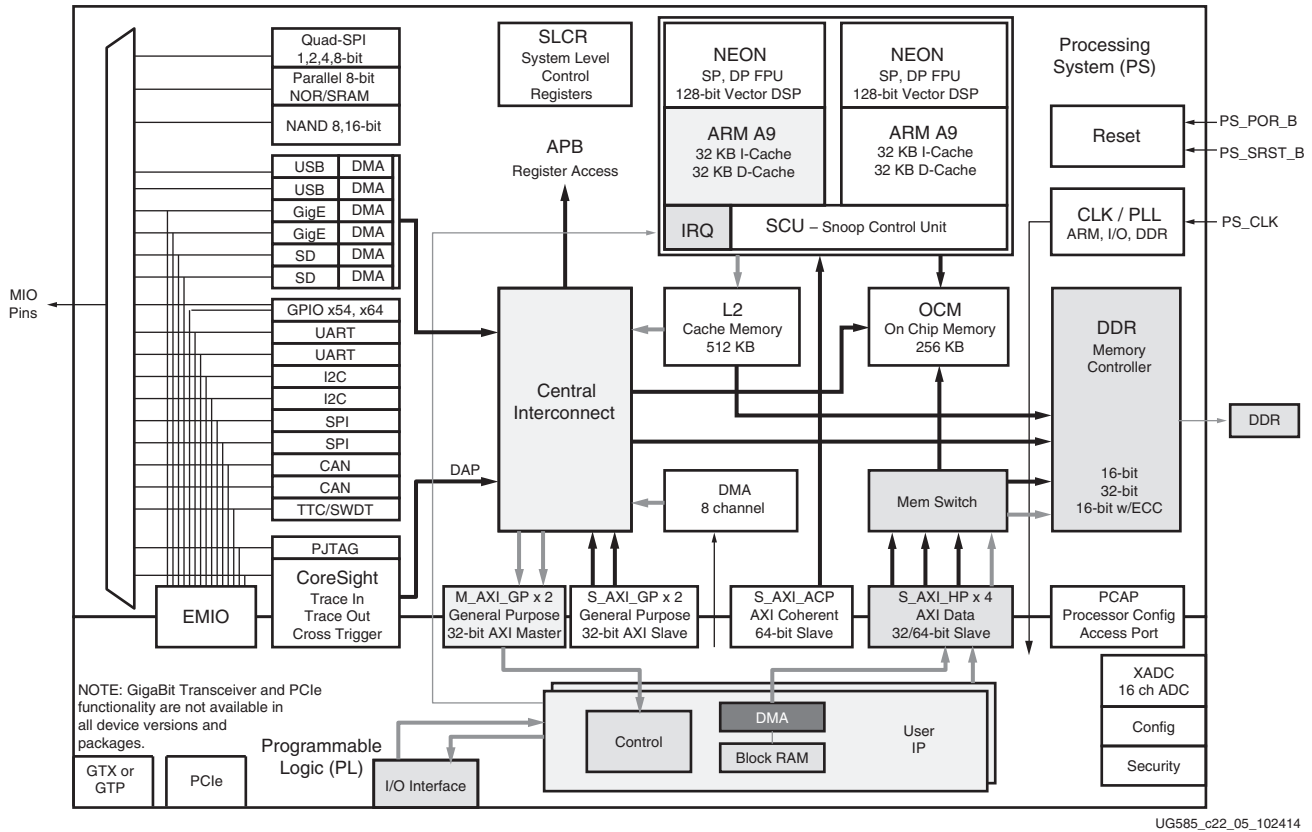

Figure 22-3: Example High-Performance (HP) DMA Topology

22.4.5 PL DMA via AXI ACP

The AXI ACP interface (S_AXI_ACP) provides a similar user IP topology as the high performance S_AXI_HP interfaces. Also 64 bits wide, the ACP also provides highest throughput capability for a single AXI interface. As shown in Figure 22-4, the User IP topology is likely often similar to the S_AXI_HP example in the previous section.

The ACP differs from the HP performance ports due to its connectivity inside of the PS. The ACP connects to the snoop control unit (SCU) which is also connected to the CPU L1 and the L2 cache. This connectivity allows ACP transactions to interact with the cache subsystems, potentially decreasing total latency for data to be consumed by a CPU. These optionally cache-coherent operations can prevent the need to invalidate and flush cache lines. The ACP also has the lowest memory latency to memory of the PL interfaces. The connectivity of the ACP is similar to that of the CPUs.

The drawbacks from using the ACP besides those shared with the S_AXI_HP interfaces also stem from the locality to the cache and CPUs. Memory accesses through the ACP utilize the same interconnect paths as the APU, potentially decreasing CPU performance. Large, coherent ACP transfers can cause thrashing of the cache. Thus ACP coherent transfers are best suited for less than the largest data-sets. The ACP low-latency access allows opportunity for algorithm acceleration of medium granularity.

For more information on S_ACI_ACP, see [Chapter 3, Application Processing Unit](#). See [Chapter 29, On-Chip Memory \(OCM\)](#) when using ACP with OCM.

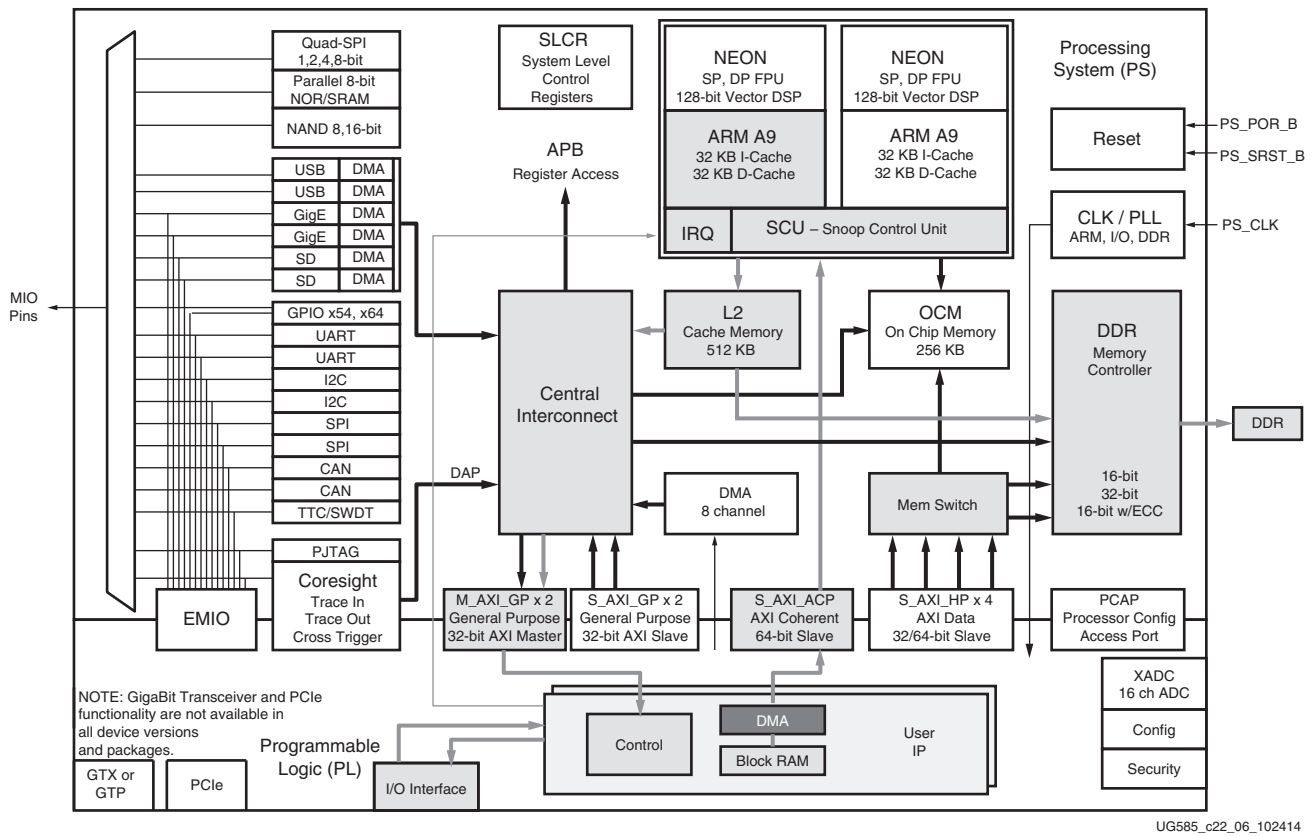

Figure 22-4: Example ACP DMA Topology

22.4.6 PL DMA via General Purpose AXI Slave (GP)

While the general purpose AXI Slave (S_AXI_GP) has reasonably low latency to OCM and DDR, its narrow 32-bit interface limits its utility as a DMA interface. The two S_AXI_GP interfaces are more likely to be used for lower-performance control access to the PS memories, registers and peripherals.

More information on the S_AXI_GP interfaces can be found in [Chapter 5, Interconnect](#).

Programmable Logic Test and Debug

23.1 Introduction

Zynq-7000 SoC devices provides extensive debug capability for accessing the PS debug structure (see [Chapter 28, System Test and Debug](#)) from the PL. This allows for integrated test and debug on both PS and PL simultaneously.

Xilinx provides the fabric trace monitor (FTM) for programmable logic test and debug. It is based on the Arm CoreSight architecture, and is a component of the trace source class (see [Chapter 28, System Test and Debug](#)) in the CoreSight system within Zynq-7000 SoC devices. The FTM receives trace data from the PL and formats it into trace packets to be combined with the trace packets from other trace source components such as PTM and ITM. With this capability, PL events can easily be traced simultaneously with PS events. The FTM also supports cross-triggering between the PS and PL, except for the trace dumping feature. In addition, the FTM provides general-purpose debug signals between the PS and PL.

23.1.1 Features

The key features of the PL test and debug are as follows:

- Arm CoreSight compliant
- 32-bit trace data from the PL
- 4-bit trace ID from the PL
- Clock domain crossing between the PL and PS
- FIFO buffering for trace packets to absorb bursts of trace data from the PL
- Indication of FIFO overflow via generation of an overflow packet
- Trace packets are compatible with Arm trace port software and hardware
- Trigger signals to/from the PL
- General-purpose I/Os to/from the PL

23.1.2 Block Diagram

A block diagram of the FTM is shown in Figure 23-1.

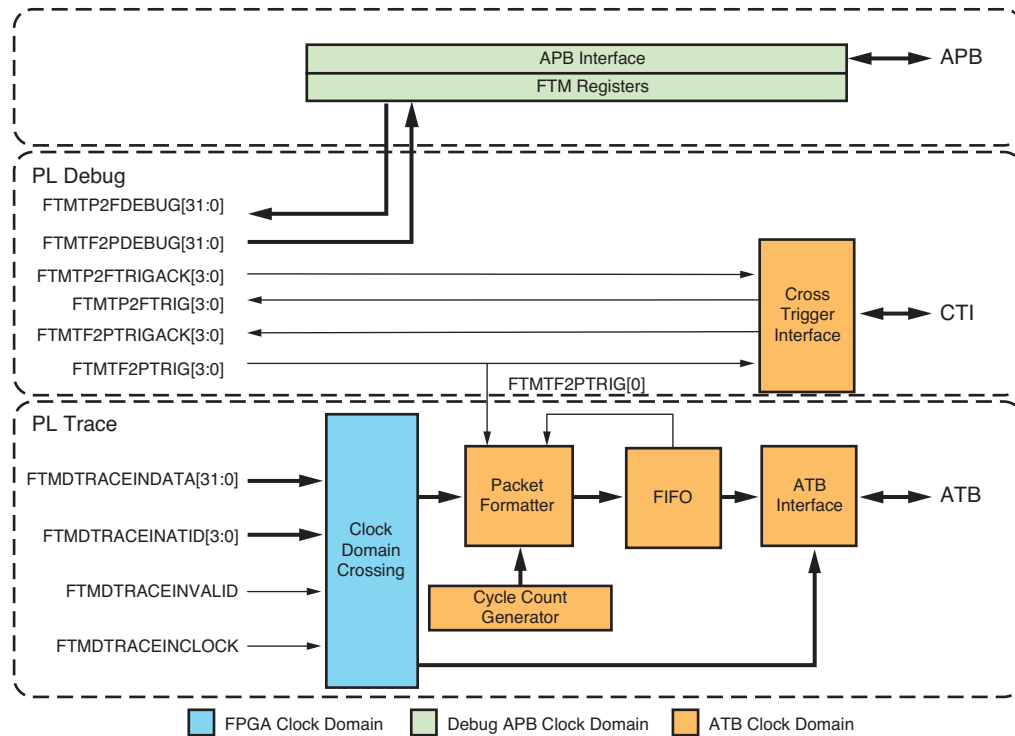

UG585_c23_01_030312

Figure 23-1: FTM Block Diagram

As shown in Figure 23-1, the following functional blocks comprise the FTM:

- APB Interface
 - This is the interface to the CoreSight debug APB, through which CPUs and JTAG can interact with the FTM.
- FTM Registers
 - These are programmable registers.
- Clock Domain Crossing
 - This block synchronizes signals between the PL clock domain and the PS clock domain.
- PL Debug Ports
 - This block provides:
 - General purpose I/Os, 32 bits to the PL and 32 bits from the PL. These are accessed through reads and writes to registers.
 - Trigger signals, 4 pairs to the PL and 4 pairs from the PL. Each pair consists of a trigger signal and an acknowledge signal, and follows Arm standard CTI handshake protocol.

- Trigger input 0 (FTMTF2PTRIG[0]) can be used to generate trigger packets.
- Packet Formatter
 - This block is responsible for gathering trace data and formatting the data into trace packets. In addition to trace packets, the packet formatter can also generate various other types of packets to convey additional information to the CoreSight system within the PS.
- Cycle Count Generator
 - This block is used to provide a binary count value for time stamping packets. This is achieved by a counter, which is:
 - 32-bit, free-running, clocked by CPU_2x
 - Pre-scaled by $2^{\text{CYCOUNTPRE}}$ (range:1 to 32,768)
 - Reset by POR, FTMGLBCTRL[FTMENABLE]=0, CoreSight reset request through JTAG
- FIFO
 - The FIFO is used to buffer packets before they are sent to the ATB. The FIFO has these properties:
 - 64-packets deep
 - When the FIFO overflows, it signals the packet formatter to generate an overflow packet. In this case, some trace data is lost.
- ATB Interface
 - This is the interface to the CoreSight ATB, over which packets are sent.
- Cross Trigger Interface
 - This block is the interface to the CoreSight ECT system (see [Chapter 28, System Test and Debug](#)).

23.1.3 System Viewpoint

For details on how the FTM is connected to, and interacts with, the rest of the CoreSight system within the PS, see [Chapter 28, System Test and Debug](#).

23.2 Functional Description

23.2.1 Basic Operation

The PL trace module captures the trace data from the PL. The user supplies the trace data, trace ID, valid, and clock signals to the FTM at the PL-PS boundary. All data, ID, and valid signals must be stable on the rising edge of the FTMDTRACEINCLOCK signal for the FTM to correctly sample them.

When FTMDTRACEINVALID is asserted, the PL trace signals are available to the clock domain crossing interface, which synchronizes the data and ID, and sends them to the packet formatter.

The packet formatter generates packets and submits them to the FIFO. The packet formatter can generate the following types of packets:

- Trace packets: These packets are generated when valid trace data is available from the PL.
- Trigger packets: These trigger packets can only be generated by the FTMTF2PTRIG[0] signal.
- Cycle count packets: These packets provide continuous timestamps that are used to reconstruct a real-time trace.
- Overflow packets: These packets are generated when the FIFO overflows.
- Synchronization packets: These packets are for packet analysis tools to re-align to packet boundaries.

The cross trigger interface communicates with the CoreSight ECT structure. This interface passes re-synchronized trigger signals between the PL and the ECT. This provides the capability of cross-triggering each other between the PS and PL.

23.2.2 Packet Generation

The following are some common scenarios that illustrate packet generation by the FTM.

Typical Case – Trace Enabled, Cycle Count Enabled

When a valid PL trace (FTMDTRACEINVALID is asserted) is captured, a trace packet and a cycle count packet are generated and sent to the ATB. When a trigger occurs (via the FTMTF2PTRIG[0] signal), a trigger packet and a cycle count packet are generated and sent to the ATB.

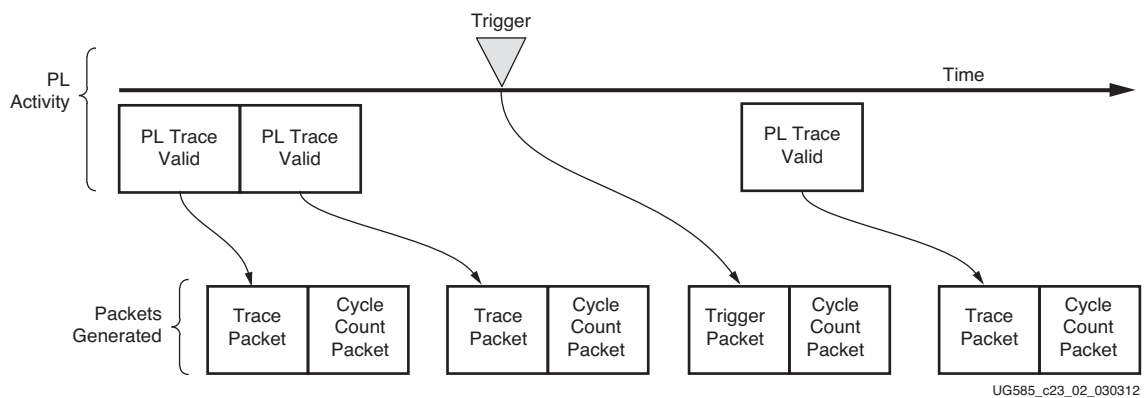

Figure 23-2: Packet Generation, Typical Case

No Cycle Count Case – Trace Enabled, Cycle Count Disabled

This is similar to the preceding case, except that cycle count packets are not generated.

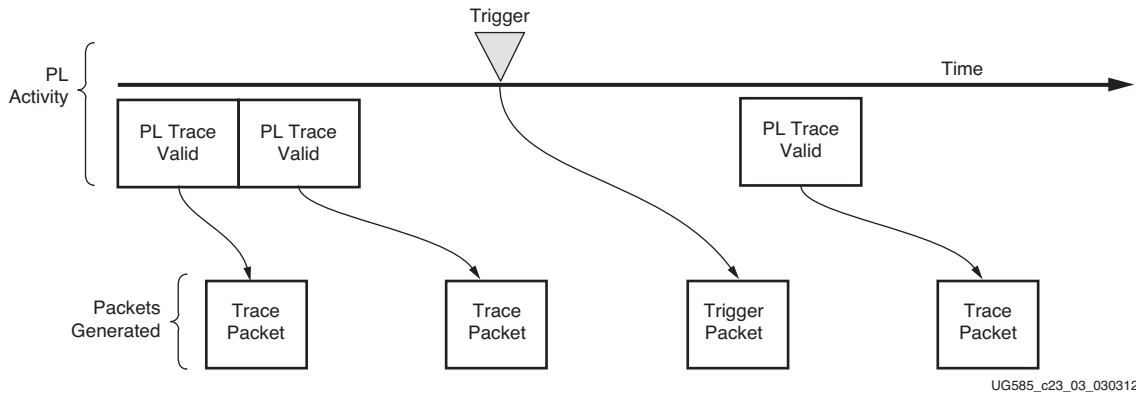

Figure 23-3: Packet Generation, No Cycle Count Case

FIFO Overflow Case – Lost Trace

In this scenario, trace packets are not generated until the FIFO is no longer in an overflow condition. An overflow packet is generated to indicate that there was an overflow condition and some trace packets are lost. At least 8 clock cycles of FTMDTRACEINCLOCK are needed between FTMDTRACEINDATA packets to avoid a FIFO overflow condition.

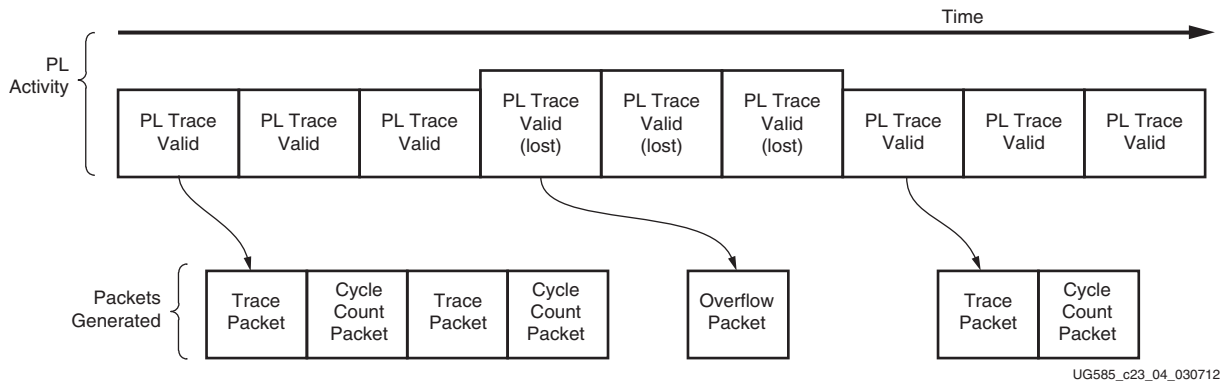

Figure 23-4: Packet Generation, FIFO Overflow Case

Synchronization Case

This scenario illustrates how a synchronization packet is generated amid other types of packets. The FTMSYNCRELOAD register sets the number of packets for which a synchronization packet must be generated.

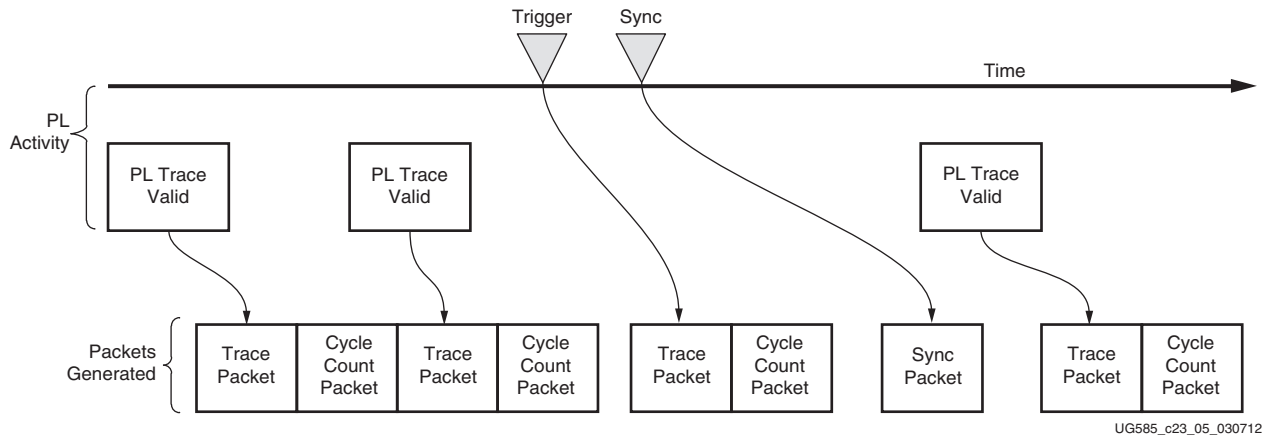

Figure 23-5: Packet Generation, Synchronization Case

23.2.3 Packet Format

General Format

A packet consists of a number of bytes. Table 23-1 shows the basic format of a packet. Except for the synchronization packet and the cycle count packet, the first and the last bytes of a packet have their MSB set to 0 to signify the start/stop of the packet; all bytes between the first and the last bytes have their MSB set to 1.

Table 23-1: General Packet Format

| Byte | [7] | [6:0] |
|------|-----|-------|
| 0 | 0 | type |
| 1 | 1 | data |
| ... | 1 | data |
| n | 0 | data |

Table 23-2 shows the encoding values for the “type” byte.

Table 23-2: “Type” Byte Encoding

| Type | [7] | [6:3] | [2:0] |
|--------------------|-----|------------|-------|
| Trace packet | 0 | trace[3:0] | 101 |
| Trigger packet | 0 | 0100 | 000 |
| Cycle count packer | 1 | count[3:0] | 100 |

Table 23-2: "Type" Byte Encoding (Cont'd)

| Type | [7] | [6:3] | [2:0] |
|------------------------|-----|-------|-------|
| FIFO overflow packet | 0 | 1101 | 000 |
| Synchronization packet | 0 | 0000 | 000 |

Trace Packet

A trace packet contains the 32-bit value from each captured FTMDTRACEINDATA[31:0] from the PL. The MSB of the last byte is determined by the presence of an immediately following cycle count packet. If a cycle count packet follows, the MSB is 1, otherwise it is 0.

Table 23-3: Trace Packet Format

| Byte | [7] | [6:0] |
|------|-------|----------------|
| 0 | 0 | data[3:0], 101 |
| 1 | 1 | data[10:4] |
| 2 | 1 | data[17:11] |
| 3 | 1 | data[24:18] |
| 4 | count | data[31:25] |

Trigger Packet

A trigger packet is generated for each acknowledged trigger input [0] from the PL, i.e., when both FTMTF2PTRIG[0] and FTMTF2PTRIGACK[0] are High.

Table 23-4: Trigger Packet Format

| Byte | [7:0] |
|------|--------------|
| 0 | 0x20 |
| 1 | 0xA0 |
| 2 | 0xA0 |
| 3 | 0x20 or 0xA0 |

Cycle Count Packet

A cycle count packet is generated when FTMCONTROL[CYCEN] is set, and a trace packet or a trigger packet is generated. It contains a binary count value taken from the current value of the internal 32-bit free-running counter. It is always a continuation of an immediately preceding trace packet or trigger packet.

Table 23-5: Cycle Count Packet Format

| Byte | [7] | [6:0] |
|------|-----|-----------------|
| 0 | 1 | count[3:0], 100 |
| 1 | 1 | count[10:4] |
| 2 | 1 | count[17:11] |

Table 23-5: Cycle Count Packet Format (Cont'd)

| Byte | [7] | [6:0] |
|------|-----|--------------|
| 3 | 1 | count[24:18] |
| 4 | 0 | count[31:25] |

FIFO Overflow Packet

A FIFO overflow packet is generated when a FIFO overflow occurs.

Table 23-6: Overflow Packet Format

| Byte | [7:0] |
|------|-------|
| 0 | 0x68 |
| 1 | 0xE8 |
| 2 | 0xE8 |
| 3 | 0x68 |

First Packet After Enable

The trace buffer might include a packet with the value 0x28A8A828 after the FTM is enabled.

Synchronization Packet

A synchronization packet allows the packet analysis tools to periodically re-align to correct packet boundaries, because the packet formatter does not maintain 32-bit word boundaries for packets. The synchronization packet follows the same format as other CoreSight components.

Table 23-7: Synchronization Packet Format

| Byte | [7:0] |
|------|-------|
| 0-7 | 0x00 |
| 8 | 0x80 |

23.3 Signals

The FTM control signals are described in the following sections.

23.3.1 General-Purpose Debug Signals

Table 23-8: General-Purpose Debug Signals

| Group | PS-PL Signal | IO | Description |
|------------------------------|---------------------|----|---|
| General purpose debug output | FTMTP2FDEBUG[7:0] | O | The FTMP2FDBG0 register controls its value. |
| | FTMTP2FDEBUG[15:8] | O | The FTMP2FDBG1 register controls its value. |
| | FTMTP2FDEBUG[23:16] | O | The FTMP2FDBG2 register controls its value. |
| | FTMTP2FDEBUG[31:24] | O | The FTMP2FDBG3 register controls its value. |
| General purpose debug input | FTMTF2PDEBUG[7:0] | I | The FTMF2PDBG0 register shows its value. |
| | FTMTF2PDEBUG[15:8] | I | The FTMF2PDBG1 register shows its value. |
| | FTMTF2PDEBUG[23:16] | I | The FTMF2PDBG2 register shows its value. |
| | FTMTF2PDEBUG[31:24] | I | The FTMF2PDBG3 register shows its value. |

23.3.2 Trigger Signals

Table 23-9: Trigger Signals

| Group | PS-PL Signal | IO | Description |
|-----------------------|---------------------|----|--|
| Trigger from PS to PL | FTMTP2FTRIG[3:0] | O | Each bit is an asynchronous trigger signal from the CoreSight ECT structure in the PS to the PL. Users must program the CTI connected to the FTM to enable these trigger output signals. |
| | FTMTP2FTRIGACK[3:0] | I | Each bit is the asynchronous acknowledge signal for the corresponding FTMTP2FTRIG signal. |
| Trigger from PL to PS | FTMTF2PTRIG[3:0] | I | Each bit is an asynchronous trigger signal from the PL to the CoreSight ECT structure in the PS. Users must program the CTI connected to FTM to enable these trigger input signals. |
| | FTMTF2PTRIGACK[3:0] | O | Each bit is the asynchronous acknowledge signal for the corresponding FTMTF2PTRIG signal. |

23.3.3 Trace Signals

Table 23-10: Trace Signals

| Group | PS-PL Signal | IO | Description |
|---------------------|-----------------------|----|---|
| Trace from PL to PS | FTMDTRACEINCLOCK | I | Clock signal for the trace data interface. Asynchronous to the PS. |
| | FTMDTRACEINVALID | I | When this signal is sampled High by the PS using FTMDTRACEINCLOCK, the values on TRMDTRACEINDATA and FTMDTRACEINATID are valid. |
| | FTMDTRACEINDATA[31:0] | I | Trace data. All 32 bits must be provided. |
| | FTMDTRACEINATID[3:0] | I | Trace ID to be carried over to the ATB. All 4 bits must be provided. |

23.4 Register Overview

Table 23-11: Register Overview

| Function | Name | Overview |
|-------------------------|--|--|
| Control | FTMGLBCTRL FTMCONTROL | Enable FTM, enable cycle count packets, enable trace packets. |
| Status | FTMSTATUS | Idle status, security signal values, FIFO full/empty. |
| General debug | FTMP2FDBG FTMF2PDGB | Set the values of the signals presented to the PL. Read the values of the signals from the PL. |
| Cycle counter prescaler | FTMCYCCOUNTPRE | Set the prescaler value for the cycle counter. |
| Synchronization counter | FTMSYNCRELOAD FTMSYNCCOUNT | Set how often synchronization packets should be generated. |
| Configuration | FTMDTRACEINATID | Set the ATID value to the ATB bus. |
| CoreSight management | Peripheral ID Component ID Device ID, type Authentication Integration test | These registers provide: <ul style="list-style-type: none"> • Identification information • Authentication and access control • Integration test |

23.5 Programming Model

23.5.1 FTM Security

FTM security is controlled through the use of the standard CoreSight mechanisms, the SPNIDEN, SPIDEN, NIDEN, and DBGEN signals from the DevC module.

The following actions are taken by the FTM when the corresponding signals are asserted:

- SPNIDEN: FTM trace operations can be enabled.
- SPIDEN: The FTMP2FDBG registers can be modified.
- NIDEN: No effect.
- DBGEN: No effect.

Power Management

24.1 Introduction

Power optimization can start with selecting the right Zynq-7000 SoC device. For low-power applications, choose either the 7z010 or 7z020 dual core device or the 7z007s, 7z012s, or 7z014s single core device. Power can dramatically be reduced by shutting-down the PL side of the device. I/O voltage and termination choice also affects power consumption. The clocks to individual PS subsystems can be stopped.

The functionality of the PS is the same for all Zynq-7000 SoC devices except that the 7z007S and 7z010 devices have a reduced MIO pin count which impacts the availability of the Ethernet, USB and other controllers. The two Zynq data sheets describe the clock frequency differences. The PL resource differences for each device type are shown in section [21.1.2 PL Resources by Device Type](#).

Detailed device level power estimates for the PS and PL can be obtained using the XPE power estimator spreadsheet. Power specifications are found in the Zynq-7000 SoC device datasheets (see [Appendix A, Additional Resources](#) for a list of related documents).

24.1.1 Features

Key system power management features are as follows.

- Choose between device technology:
 - 7z010 and 7z020 dual core or 7z007s, 7z012s, or 7z014s single core (derived from Artix AP FPGA technology)
 - 7z030, 7z035, 7z045, and 7z100 (derived from Kintex AP FPGA technology)
- PL power-off
- Cortex A9 processor standby mode
- Clock gating for most PS subsystems
- Three PLLs can be programmed to minimize power consumption
- Subsystem clocks can be programmed for optional clock frequency
- Programmable voltage for I/O Banks:
 - MIO: HSTL 1.8V, LVCMOS 1.8V, 2.5V and 3.3V
 - DDR: DDR2 1.8V, DDR3 1.5V and LPDDR2 1.2V
- DDR3 and LPDDR2 low power mode

- DDR 16 or 32-bit data I/O
- Internal and external voltage measurements using XADC

24.2 System Design Considerations

The section includes these system design considerations:

- [24.2.1 Device Technology Choice](#)
- [24.2.2 PL Power-down Control](#)
- [24.2.3 APU Maximum Frequency](#)
- [24.2.4 DDR Memory Clock Frequency](#)
- [24.2.5 DDR Memory Controller Modes and Configurations](#)
- [24.2.6 Boot Interface Options](#)
- [24.2.7 PS Clock Gating](#)

24.2.1 Device Technology Choice

There is a power and performance distinction between the low power devices (7z010/7z020 dual core and 7z007s/7z012s/7z014s single core) and the high performance devices (7z030, 7z035, 7z045, and 7z100). The low power devices are derived from the 7 series Artix AP FPGAs. The larger and higher performance devices are derived from the Kintex AP FPGAs.

Within the PS and PL, multiple power supplies are used to power core logic, I/Os, and auxiliary circuits. Independent I/O banks allow a mix of 1.8V, 2.5V, and 3.3V I/O standards. The PS also contains a DDR interface supporting DDR2, DDR3, and LPDDR2 which operate at 1.8V, 1.5V and 1.2V, respectively.

The Zynq-7000 SoC family supports voltage and temperature monitoring by utilizing the sensors in the Xilinx ADC (XADC) subsystem (refer to [Chapter 30, XADC Interface](#)). The XADC provides real-time monitoring of voltage and temperature levels within the device.

24.2.2 PL Power-down Control

In case the PL is not used, it can be completely shut down to save power. This requires independently connected power supplies for the PS and PL. Furthermore, some restrictions apply during boot and power off. Refer to [DS187](#) and [DS191](#), *Zynq-7000 SoC DC and AC Switching Characteristics* for more details. An example sequence to power-down the PL is provided in section [2.4 PS-PL Voltage Level Shifter Enables](#).

The PL power system can be controlled via GPIOs, the I2C controller, or an external processor. When the PL is powered off all PS to PL signals, including EMIO, PL AXI, should not be accessed.

The PL loses its configuration when powered down and must be reconfigured when it is powered on again. Software should determine when it is safe to power down the PL.

24.2.3 APU Maximum Frequency

For applications which do not require the maximum amount of processing performance, the APU maximum frequency can be reduced to meet application needs. A lower clock frequency can significantly reduce the operating power when compared to operating at a higher frequency.

24.2.4 DDR Memory Clock Frequency

For applications which do not require the maximum amount of DDR bandwidth, the DDR bandwidth can be reduced to meet application needs. This can reduce operating power significantly compared operating at a higher frequency, but more importantly, allows the use of lower power DDR standards and configurations.

24.2.5 DDR Memory Controller Modes and Configurations

The DDR2, DDR3, and LPDDR2 DDR standards are supported in both 16- and 32-bit data operation. DDR power can be a significant percentage of total power, so minimizing DDR power is an important means of reducing system power.

The following features impact DDR power:

- The highest power DDR standard is a DDR2 due to the 1.8V operating voltage and the termination requirements.
- The highest speed DDR standard is DDR3 operating up to 1,066 Mb/s in -1 devices.
- The lowest power interface DDR standard is LPDDR2 due to the 1.2V operating voltage and the unterminated I/Os, however rates are limited compared to DDR3.
- DDR width can be set to 16 or 32 bits. Note that, for ECC, use a 32-bit bus width (16-bit data, 10-bit ECC).
- The total number of DDR devices in the system impacts system power. For example, four 8-bit DDR devices have a higher system power than two 16-bit devices.
- 32-bit DDR devices are available only for LPDDR2.
- Termination strength: If possible use the highest possible termination value. A termination value of 40Ω is 50% more termination power than 60Ω.

24.2.6 Boot Interface Options

The PS supports boot from Quad-SPI, NAND, and NOR devices. Boot devices do not impact system level dynamic power as the boot process only occurs once at device power up. Lower voltage 1.8V devices are of lower static power than higher 3.3V devices.

24.2.7 PS Clock Gating

The PS supports many clock domains, each with independent clock gating control. When the system is in run mode, the user is allowed to shut down the clock domains that are not used and reduce the dynamic power dissipation.

24.3 Programming Guides

24.3.1 System Modules

The power management features of the Zynq-7000 SoC's system modules are described in detail in their respective chapter. Please refer to [Table 24-4](#) for an overview and further references.

Table 24-1: Power Management for System Modules

| System Module | Clocked in Standby Mode | Description |
|----------------|-------------------------|--|
| APU | Yes | See Chapter 3, Application Processing Unit . |
| SCU (with GIC) | Yes | See Chapter 3, Application Processing Unit . |
| L2-Cache | Yes | See Chapter 3, Application Processing Unit . |
| Interconnect | Yes | Clocks are stopped automatically if enabled, refer to Chapter 25, Clocks . |
| Peripherals | Depends | Peripheral used as a wake-up source must be clocked, refer to Table 24-2 . |

24.3.2 Peripherals

The primary peripheral power management mechanisms are clock scaling and gating. [Chapter 25, Clocks](#) describes the system clocks and how they can be controlled through dividers, gates, and multiplexers. [Table 24-2](#) gives a brief overview of the power management capabilities for the device subsystems. Every peripheral includes clock gating and, in some cases, low-power states.

With all these pieces working together, the system-level sleep mode is defined. (Refer to section [24.4 Sleep Mode](#).) In sleep mode the whole chip enters a low-power state, waiting for a wake-up event to continue operation.

Peripheral Clock Gating

For peripherals with an independent clock domain for the interconnect, disable the device's interconnect clock last and enable it first to avoid accesses to inaccessible register areas. See [Chapter 25, Clocks](#) and the respective chapter for a peripheral for additional details.

Table 24-2: Power Management for Peripheral Controls

| Peripheral | Wake-up Source | Clock Gating Low-Power Mode | Other Low-Power Modes |
|----------------|--|---|-----------------------|
| PCAP | No | No | None |
| Timers | Yes Chapter 8, Timers | Yes Chapter 25, Clocks | None |
| DMA Controller | No | Yes Section 9.6 System Functions | None |

Table 24-2: Power Management for Peripheral Controls (Cont'd)

| Peripheral | Wake-up Source | Clock Gating Low-Power Mode | Other Low-Power Modes |
|--------------------------|--|---|--|
| DDR Controller | No | Yes Section 10.9 Operational Programming Model | Yes |
| Static Memory Controller | No | Yes 11.2.2 Clocks | None |
| Quad-SPI Controller | No | Yes Section 12.4 System Functions | None |
| SDIO Controller | No | Yes Chapter 25, Clocks | None |
| GPIO Controller | Yes Section 14.4 System Functions | Yes Section 14.4 System Functions | None |
| USB Controller | | Yes Chapter 15, USB Host, Device, and OTG Controller | Suspended/Resume Chapter 15, USB Host, Device, and OTG Controller |
| Ethernet Controller | | Yes Chapter 25, Clocks | |
| SPI Controller | No | Yes 18.4 System Functions | |
| CAN Controller | | Yes 18.4 System Functions | Sleep Mode 18.2.1 Controller Modes |
| UART Controller | Yes 19.3.5 RxFIFO Trigger Level Interrupt | Yes 19.4 System Functions | None |
| I2C Controller | No | Yes 20.4 System Functions | None |
| Programmable Logic | | Yes Chapter 25, Clocks | User Defined |

24.3.3 I/O Buffers

Power management for I/O buffer controls are shown in Table 24-3.

Table 24-3: Power Management for I/O Buffer Controls

| I/O Buffer | Signal Voltage | Termination and Mode |
|---------------|----------------|--|
| DDR | 1.8V/1.5V/1.2V | See section 10.6.3 DDR IOB Configuration |
| MIO0 and MIO1 | 1.8V/2.5V/3.3V | |

24.4 Sleep Mode

Sleep mode is defined at the system level to include the APU in standby mode and multiple controllers being held in reset without a clock.

Going into sleep mode can greatly reduce power consumption. In sleep mode, most function clock groups are turned off or powered off. The only required active devices are one CPU, the snoop control unit (SCU), and a wake-up device. Ideally, the only devices causing dynamic power consumption should be the SCU and the wake-up peripheral device. The wake-up device can be UART, GPIO, or any device that can generate an interrupt.

If the wake-up device is an AXI bus master, which can start transactions targeting the DRAM, additional limitations apply. Because the whole interconnect and the DDR memory are in low power modes and inaccessible, it must be assured that the CPU goes through the full wake-up process before any transactions to the DRAM take place. This guarantees that potential transactions targeting the DRAM are served correctly.

24.4.1 Setup Wake-up Events

Every interrupt signaled to the PS can be used as a wake-up event. To make this happen, the wanted interrupt must be enabled in the peripheral and the GIC. A wake-up device must be able to generate the interrupt in sleep mode, which means, that its clocks might not be gated off. See [GPIO as Wake-up Event, page 395](#) for more information.

Refer to the respective chapter for information about available interrupts and how to configure the peripherals to generate them.

24.4.2 Programming Guide

The following shows the preliminary steps to enter PS sleep mode from normal running mode and exit from it. In sleep mode, the master CPU is responsible for shutting down all non-wake up devices, including all other masters in the system and the PL, if possible. Since clock frequencies change when clock dividers and PLL configurations are changed, configuring a wake-up device might not only mean activating the wanted wake-up interrupt, but also changing the peripheral configuration to be able to cope with the modified clock frequency. If both CPUs are running, the master CPU should shut down the secondary CPU first before proceeding with the steps described below. It is user's choice, which CPU acts as master CPU. Furthermore, precautions must be taken to keep code which is executed while the DDR clocks are disabled accessible in this period e.g., by placing those code-segments in OCM, or locking the L2 cache and TLB. Depending on the actual implementation this can, amongst others, apply to:

- Code executed when DDR is not available
- Routine for entering and exiting standby mode
- Translation table
- Stacks

The location of the currently used translation table(s) and stacks are controllable through the TTBR and SP registers, respectively. This allows switching between different structures for normal running mode and standby mode if needed.

During the standby sequence interrupts are disabled in the CPUs. This way execution cannot be interrupted while entering standby mode and once the wake-up event occurs execution resumes right after the *wfi* instruction instead of jumping to a vector table. The wake-up interrupt must be enabled in the corresponding wake-up device and in the GIC interrupt controller to cause a qualified wake-up event. Once interrupts are re-enabled after waking up, the wake-up interrupt is still pending and causes the CPU to jump to its interrupt handler, as usual.

Enter Sleep Mode

A CPU must execute the following steps to enter sleep mode from normal run mode:

1. **Disable interrupts.** Execute `cpsid if`.
2. **Configure wake-up device.**
3. **Enable L2 cache dynamic clock gating.** Set `l2cpl310.reg15_power_ctrl[dynamic_clk_gating_en] = 1`.
4. **Enable SCU standby mode.** Set `mpcore.SCU_CONTROL_REGISTER[SCU_standby_enable] = 1`.
5. **Enable topswitch clock stop.** Set `slcr.TOPSW_CLK_CTRL[CLK_DIS] = 1`.
6. **Enable Cortex-A9 dynamic clock gating.** Set `cp15.power_control_register[dynamic_clock_gating] = 1`.
7. **Put the external DDR memory into self-refresh mode.** Refer to section [10.9.6 DDR Power Reduction](#).
8. **Put the PLLs into bypass mode.** Set `slcr.{Arm, DDR, IO}_PLL_CTRL[PLL_BYPASS_FORCE] = 1`.
9. **Shut down the PLLs.** Set `slcr.{Arm, DDR, IO}_PLL_CTRL[PLL_PWRDWN] = 1`.
10. **Increase the clock divisor to slow down the CPU clock.** Set `slcr.ARM_CLK_CTRL[DIVISOR] = 0x3f`.
11. **Execute the *wfi* instruction to enter WFI mode.**

Exit Sleep Mode

Exiting sleep mode is triggered by the configured interrupt occurring. The interrupt wakes up the CPU which resumes execution. The newly starting activity also triggers the topswitch, SCU, and L2 cache controller to leave their idle states and continue normal operation. The procedure for waking up is outlined below.

To exit from sleep mode:

1. **Restore CPU clock divisor setting.** Set `slcr.ARM_CLK_CTRL[DIVISOR] = <original value>`.
2. **Power on the PLLs.** Set `slcr.{ARM, DDR, IO}_PLL_CTRL[PLL_PWRDWN] = 0`.
3. **Wait for PLL power-on and lock.** Wait for `slcr.PLL_STATUS[{ARM, DDR, IO}_PLL_LOCK] == 1`.
4. **Disable PLL bypass mode.** Set `slcr.{ARM, DDR, IO}_PLL_CTRL[PLL_BYPASS_FORCE] = 0`.

5. **Disable L2 cache dynamic clock gating.** Set `l2cpl310.reg15_power_ctrl[dynamic_clk_gating_en] = 0`.
6. **Disable SCU standby mode.** Set `mpcore.SCU_CONTROL_REGISTER[SCU_standby_enable] = 0`.
7. **Disable Interconnect clock stop.** Set `slcr.TOPSW_CLK_CTRL[CLK_DIS] = 0`.
8. **Disable Cortex-A9 dynamic clock gating.** Set `cp15.power_control_register[dynamic_clock_gating] = 0`.
9. Enable all required peripheral devices, including DDR controller clocks.
10. **Re-enable and serve interrupts.** Execute `cpsie if`.



IMPORTANT: *Bypassing the PLLs and modifying clock dividers change the clock frequencies in the system. Proper care must be taken clocking the wake-up device, and watchdog timers (if used), etc., under these conditions.*

24.5 Register Overview

Table 24-4 provides an overview of the power management registers.

Table 24-4: Power Management Register Overview

| Register | Description | Comment |
|--|------------------------------------|---|
| APU | | |
| <code>cp15.Power Control register</code> | | Control APU power management features |
| <code>cp15.TTBR</code> | Translation Table Base register | |
| <code>mpcore.SCU_CONTROL_REGISTER</code> | | Enable/disable SCU standby mode |
| <code>l2cpl310.reg15_power_ctrl</code> | Power Control register | |
| DDR | | |
| <code>ddrc.ctrl_reg1</code> | DDRC control register (1) | Set DDRC operating mode (e.g. self-refresh) |
| <code>ddrc.DRAM_param_reg3</code> | DRAM parameters (3) | Enable/disable clock stop |
| <code>ddrc.mode_sts_reg</code> | Controller operation mode status | |
| PS Clock Module | | |
| <code>slcr.{ARM, DDR, IO}_PLL_CFG</code> | Program PLL clock generators | |
| <code>slcr.xxx_CLK_CTRL</code> | Enable CPU_1x and reference clocks | |
| <code>slcr.PLL_STATUS</code> | PLL stable/lock status | |

Clocks

25.1 Introduction

All of the clocks generated by the PS clock subsystem are derived from one of three programmable PLLs: CPU, DDR and I/O. Each of these PLLs is loosely associated with the clocks in the CPU, DDR and peripheral subsystems.

25.1.1 System Block Diagram

The major components of the clock subsystem are shown in Figure 25-1.

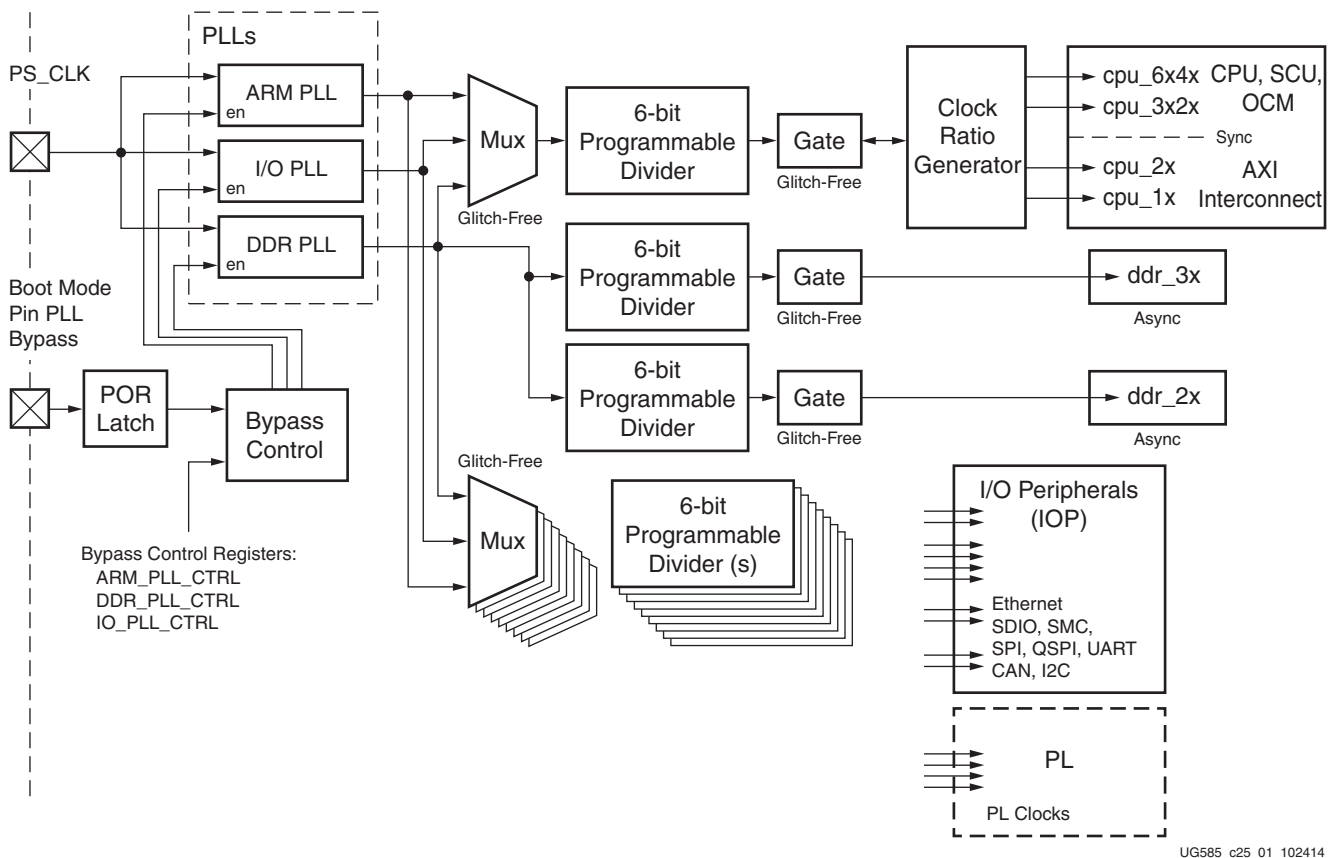

Figure 25-1: PS Clock System Block Diagram

25.1.2 Clock Generation

During normal operation, the PLLs are enabled, driven by the PS_CLK clock pin. In bypass mode, the clock signal on the PS_CLK pin provides the source for the various clock generators instead of the PLLs. (Refer to the applicable Zynq-7000 SoC data sheet for PS_CLK characteristics.)

When the PS_POR reset signal deasserts, the PLL bypass boot mode pin is sampled and selects between PLL bypass and PLL enabled for all three PLLs. The bypass mode runs the system significantly slower than normal mode, but is useful for low-power applications and debug. After the boot process and when the user code executes, the bypass mode and output frequency of each PLL can be individually controlled by software.

The clock generation paths include glitch-free multiplexers and glitch-free clock gates to support dynamic clock control.

Three Programmable PLLs

- Single external reference clock input for all three PLLs
 - Arm PLL: Recommended clock source for the CPUs and the interconnect
 - DDR PLL: Recommended clock for the DDR DRAM controller and AXI_HP interfaces
 - I/O PLL: Recommended clock for I/O peripherals
- Individual PLL bypass control and frequency programming
- Shared bandgap reference voltage circuit for VCOs

Clock Branches

- Six-bit programmable frequency dividers
- Dynamic switching on most clock circuits
- Four clock generators for the PL

Reset

The clock subsystem is an integral part of the PS and is only reset when the entire system is reset. When this occurs, all of the registers that control the clocking module return to their reset values.

25.1.3 System Viewpoint

Figure 25-1 shows the clock network and related domains from a system viewpoint.

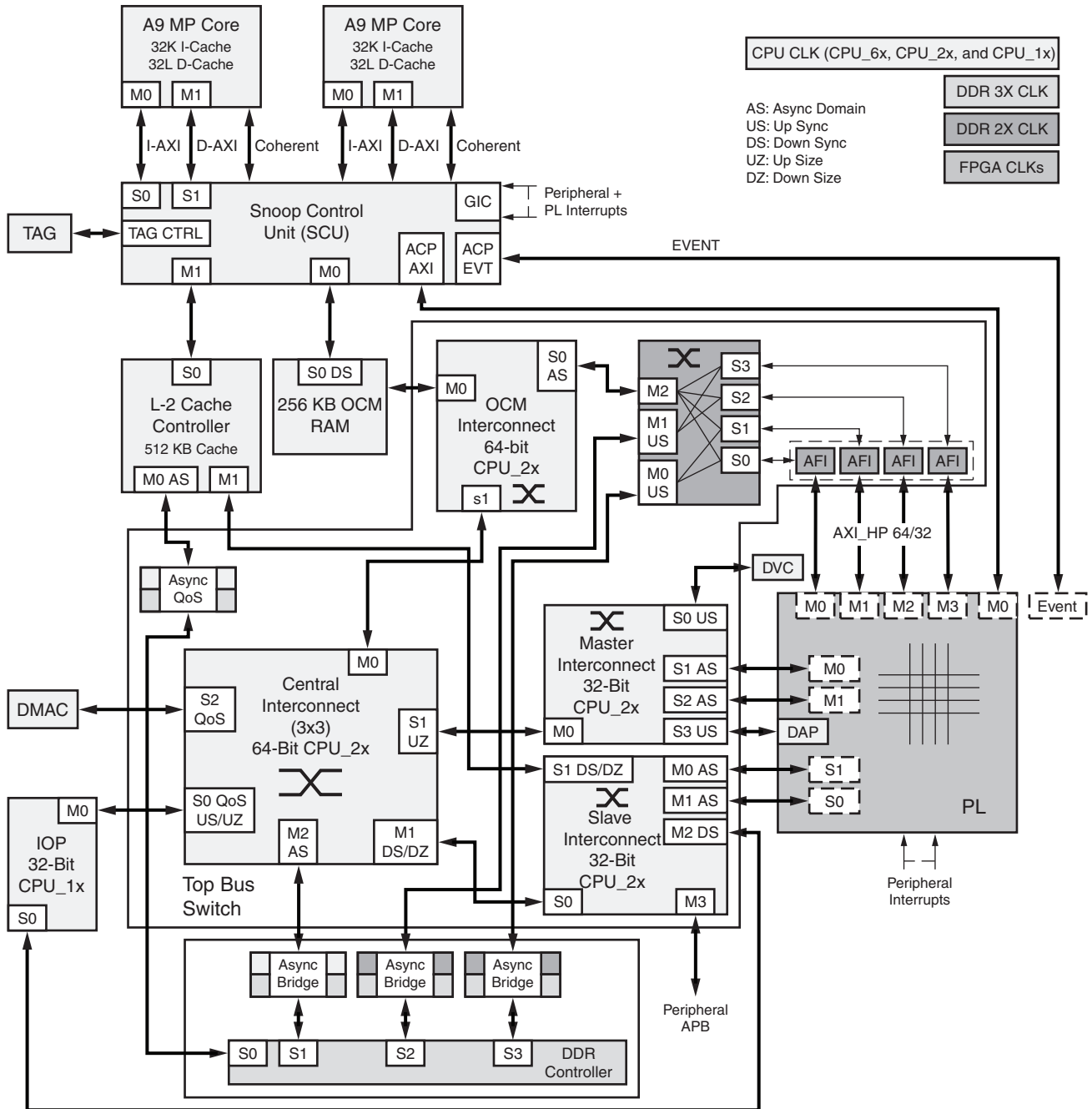

UG585_c25_02_021213

Figure 25-2: System Clock Domains

A version of the CPU clock is used for most of the internal clocking. The asynchronous DMA peripheral request interfaces between the DMAC and the PL are not shown in [Figure 25-2](#). In addition, PL AXI channels (AXI_HP, AXI_ACP and AXI_GP) have asynchronous interfaces between the PS and PL. The synchronization, where the clock domain crossing occurs, is located inside the PS. Therefore, the PL provides the interface clock to the PS. Each of the aforementioned interfaces could use unique clocks in the PL.

25.1.4 Power Management

The overall approach to power management is described in [Chapter 24, Power Management](#). The clock generation subsystem facilitates clock disabling and frequency control which affects power consumption.

The PLL power consumption is directly related to the PLL output frequency. The power consumption can be reduced by using a lower PLL output frequency. Power can also be reduced if one or two of the PLLs are not required. For example, if all of the clock generators can be driven by the DDR PLL, then the Arm and I/O PLLs can be disabled to reduce power consumption. The DDR PLL is the only unit that can drive all of the clock generators.

Each clock can be individually disabled when not in use. In some cases, individual subsystems contain additional clock disabling and other power reduction features.

Central Interconnect Clock Disable

The CPU clocks for the central interconnect (CPU_2x and CPU_1x) can be stopped by setting the TOPSW_CLK_CTRL [0] bit to a 1. When this bit is set, the clock controller waits for the AXI interfaces to the L2-cache and SCU to become idle and for the FPGAIIDLEN signal from the PL to assert before shutting off the clock to the central interconnect. For the other interfaces, the system software must ensure that the interfaces are idle before disabling the interconnect clock. As soon as the PS detects traffic on the L2-cache or the SCU, or the FPGAIIDLEN is deasserted, the clocks will be re-enabled.

25.2 CPU Clock

Figure 25-3 shows the clock generation network in the CPU clock domains.

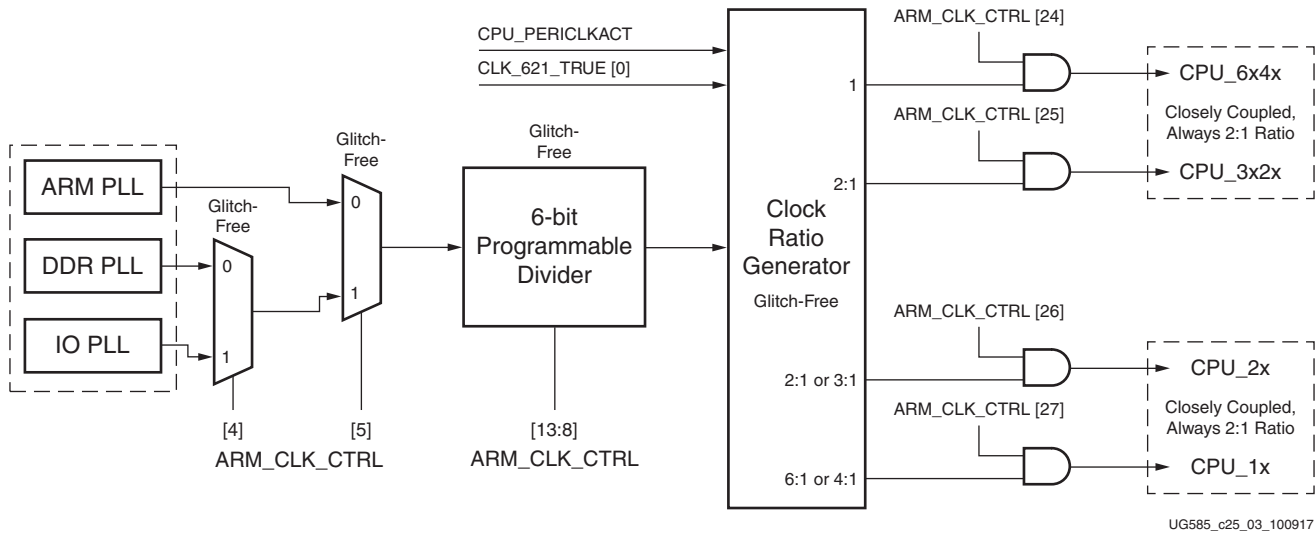

Figure 25-3: CPU Clock Generation and Domains

Ratio Examples

The CPU clock domain operates in two modes 6:2:1 and 4:2:1. Table 25-1 shows example frequencies for these modes and modules operating in each clock domain. (See the applicable Zynq-7000 SoC data sheet for the specific allowed frequencies for each clock.)

Table 25-1: CPU Clock Frequency Ratio Examples

| CPU Clock | 6:2:1 | 4:2:1 | Clock Domain Modules |
|-----------|---|---|---|
| CPU_6x4x | 800 MHz (6 times faster than CPU_1x) | 600 MHz (4 times faster than CPU_1x) | CPU clock frequency, SCU, and OCM arbitration, NEON, L2 cache memory |
| CPU_3x2x | 400 MHz (3 times faster than CPU_1x) | 300 MHz (2 times faster than CPU_1x) | APU timers |
| CPU_2x | 266 MHz (2 times faster than CPU_1x) | 300 MHz (2 times faster than CPU_1x) | I/O peripherals, central interconnect, master interconnect, slave interconnect, and OCM RAM |
| CPU_1x | 133 MHz | 150 MHz | I/O peripherals AHB and APB interface busses |

CPU Clock Divisor Restriction

To improve the quality of the high speed clocks going to the CPU and DDR, there is a requirement that they get divided by an even number in the slcr.ARM_CLK_CTRL [DIVISOR] bit field. For the slcr.ARM_CLK_CTRL [DIVISOR], software must program it to be equal or greater than 2.

Clock Usage

During normal usage, most system clocks will be derived by taking the input clock PS_CLK, sending it through the PLL, and finally dividing it down to be used within the PS. While the PS generates many different clocks, as shown in [Figure 25-1](#), there are three clock domains that have the largest interaction and importance in the system: These are the DDR_3x domain, the DDR_2x domain, and the CPU clock domain. The DDR_3x clock domain includes the DDR memory controller. The DDR_2x domain is primarily used for the high performance AXI interfaces to the PL (AXI_HP{0:3}) and the interconnect. The CPU clock domain controls the Arm processors along with many of the CPU peripherals.

The CPU clock domain is composed of four separate clocks: CPU_6x4x, CPU_3x2x, CPU_2x, and CPU_1x. These four clocks are named according to their frequencies, which are related by one of two ratios: 6:3:2:1 or 4:2:2:1 (abbreviated 6:2:1 and 4:2:1). The operating clock ratio is determined by the CLK_621_TRUE [0] bit value. In the 6:2:1 mode, the frequency of the CPU_6x4x clock is 6 times as fast as the CPU_1x clock. [Table 25-1, page 680](#) shows examples of how these clocks are related. Refer to the applicable Zynq-7000 SoC data sheet for the maximum clock frequency of each clock domain.

All the CPU clocks are synchronous to each other; while the DDR clocks are independent of each other and the CPU clocks. The I/O peripheral clocks, such as CAN reference clocks and SDIO reference clocks, are all generated by a similar method, starting from the PS_CLK pin, through a PLL, then a divider, and finally to the peripheral destination. Each peripheral clock is completely asynchronous to all other clocks.

Interconnect Clock Domains

The individual clock domains are shown in [Figure 25-2](#). The central interconnect has two main clock domains: the DDR_2x and the CPU_2x. For the five sub-switches, four clocks are in the CPU_2x clock domain, while the memory interconnect clock is in the DDR_2x clock domain. The direct path between the CPU (via the L2 cache) and DDR controller is in the DDR_3x clock domain, ensuring maximum throughput. The direct path between CPU and OCM is in the CPU_6x4x clock domain. The direct path between the SCU ACP and the PL is in the CPU_6x4x clock domain (clock domain crossing between the PL clock domain and the CPU clock domain is done in an asynchronous AXI bridge in the PS).

CPU Clock Stop

Each CPU clock can be individually stopped using `slcr.A9_CPU_RST_CTRL.A9_CLKSTOP{0,1}`.

PS Peripheral AMBA Clocks

Every peripheral within the PS is supplied with its own independently gated version of the CPU clock for its AMBA bus connection to the control and status registers and sometimes to the controller logic itself. This clock can be disabled when it is guaranteed that the peripheral is not addressed. This gating is applied with a glitch-free clock gate as shown in [Table 25-2](#).

Table 25-2: PS Peripheral Clock Control

| AMBA Bus Peripheral | Base Clock | Control Bits in APER_CLK_CTRL 0: Disable 1: Enable | |
|---------------------|------------|--|------|
| DMAC | CPU_2x | DMA_CPU_2XCLKACT | [0] |
| USB 0 | CPU_1x | USB0_CPU_1XCLKACT | [2] |
| USB 1 | CPU_1x | USB1_CPU_1XCLKACT | [3] |
| GigE 0 | CPU_1x | GEM0_CPU_1XCLKACT | [6] |
| GigE 1 | CPU_1x | GEM1_CPU_1XCLKACT | [7] |
| SDIO 0 | CPU_1x | SDIO0_CPU_1XCLKACT | [10] |
| SDIO 1 | CPU_1x | SDIO1_CPU_1XCLKACT | [11] |
| SPI 0 | CPU_1x | SPI0_CPU_1XCLKACT | [14] |
| SPI 1 | CPU_1x | SPI1_CPU_1XCLKACT | [15] |
| CAN 0 | CPU_1x | CAN0_CPU_1XCLKACT | [16] |
| CAN 1 | CPU_1x | CAN1_CPU_1XCLKACT | [17] |
| I2C 0 | CPU_1x | I2C0_CPU_1XCLKACT | [18] |
| I2C 1 | CPU_1x | I2C1_CPU_1XCLKACT | [19] |
| UART 0 | CPU_1x | UART0_CPU_1XCLKACT | [20] |
| UART 1 | CPU_1x | UART1_CPU_1XCLKACT | [21] |
| GPIO | CPU_1x | GPIO_CPU_1XCLKACT | [22] |
| Quad-SPI | CPU_1x | LQSPI_CPU_1XCLKACT | [23] |
| SMC | CPU_1x | SMC_CPU_1XCLKACT | [24] |

System Performance

The clock frequencies of the different clock domains of the PS help dictate total system performance. In many cases, the highest frequency CPU clock results in the highest performance. However, some users will find that the CPU is not the critical performer in the system and that bandwidth across the interconnect is the bottleneck. In that case, it might be useful to switch the ratio from 6:2:1 to 4:2:1 mode. Depending on the device speed grade, the frequency of the CPU clocks might be limited by the `cpu_6x` while in 6:2:1 mode and might be limited by the `cpu_2x` clock while in 4:2:1 mode. Therefore, it is suggested that for those applications that might exchange some CPU performance for interconnect performance, check the appropriate data sheet to determine the optimal frequencies.

25.3 System-wide Clock Frequency Examples

There are two clock configuration examples for 6:2:1 mode in [Table 25-3](#). The first example is when the input `PS_CLK` is at 33.33 MHz and the second example is when the input frequency is at 50 MHz.

The PLL output frequency is determined by the frequency of the input clock PS_CLK multiplied by the PLL feedback divider value (M value). The example below assumes the Arm PLL feedback divider value is 40, which generates an Arm PLL output frequency of 33.33 MHz * 40 = 1.33 GHz. For each of the clocks listed in the lower half of the table, the clock frequency equals the sourced PLL frequency divided by the divisor value. For some of the peripheral clocks, such as CAN, Ethernet, and the PL, there are two cascaded dividers.

Table 25-3: Clock Frequency Setting Examples for 6:2:1 Mode

| PS_CLK | | | Example 1 | | | Example 2 | | |
|--------------------------|-----|------------|----------------------------|------------------|----------------------------|----------------------------|-----------|----------------------------|
| PS_CLK | | | 33.33 MHz | | | 50 MHz | | |
| | | PLL | PLL Feedback Divider Value | | PLL Output Frequency (MHz) | PLL Feedback Divider value | | PLL Output Frequency (MHz) |
| | | Arm PLL | 40 | | 1333 | 20 | | 1000 |
| | | DDR PLL | 32 | | 1067 | 16 | | 800 |
| | | I/O PLL | 30 | | 1000 | 20 | | 1000 |
| Clock | No. | PLL Source | Divisor 0 | Divisor 1 | Clock Frequency (MHz) | Divisor 0 | Divisor 1 | Clock Frequency (MHz) |
| cpu_6x4x | 1 | Arm PLL | 2 | ~ ⁽¹⁾ | 667 | 2 | ~ | 500 |
| cpu_3x2x | 1 | Arm PLL | | ~ | 333 | | ~ | 250 |
| cpu_2x | 1 | Arm PLL | | ~ | 222 | | ~ | 167 |
| cpu_1x | 1 | Arm PLL | | ~ | 111 | | ~ | 83 |
| ddr_3x | 1 | DDR PLL | 2 | ~ | 533 | 2 | ~ | 400 |
| ddr_2x | 1 | DDR PLL | 3 | ~ | 356 | 3 | ~ | 267 |
| DDR DCI | 1 | DDR PLL | 7 | 15 | 10 | 7 | 15 | 8 |
| SMC | 1 | IO PLL | 10 | ~ | 100 | 12 | ~ | 83 |
| QSPI ⁽²⁾ | 1 | IO PLL | 5 | ~ | 200 | 6 | ~ | 167 |
| GigE | 2 | IO PLL | 8 | 1 | 125 | 8 | 1 | 125 |
| SDIO | 2 | IO PLL | 10 | ~ | 100 | 10 | ~ | 100 |
| UART | 1 | IO PLL | 40 | ~ | 25 | 40 | ~ | 25 |
| SPI ⁽³⁾ | 2 | IO PLL | 5 | ~ | 200 | 8 | ~ | 125 |
| CAN | 2 | IO PLL | 10 | 1 | 100 | 12 | 1 | 83 |
| PCAP_2x ⁽⁴⁾ | 1 | IO PLL | 5 | ~ | 200 | 6 | ~ | 167 |
| trace_clk ⁽⁵⁾ | 1 | IO PLL | 10 | ~ | 100 | 15 | ~ | 67 |
| PLL FCLKs | 4 | IO PLL | 20 | 1 | 50 | 20 | 1 | 50 |

Notes:

- "~" in the table indicates that there is no second divider (not applicable).
- The QSPI clock is divided down by at least 2 using the Quad-SPI baud rate divider, see section 12.4.1 Clocks.
- In master mode, the SPI clock is divided down by at least 4 using the SPI baud rate divider, see section 17.4.2 Clocks.
- The PCAP_2x clock is always twice the frequency of the PCAP clock.
- The trace_clk is always twice the frequency of the TPIU clock.

25.4 Clock Generator Design

There are several different components to each clock generation circuit. This section describes a generic template that is used to explain the pieces used for all of the following I/O peripheral clocks. The most basic types include:

- 2-to-1 multiplexers for selecting a clock source
- Programmable divider(s)
- Glitch-free clock activation gate

These features are shown in [Figure 25-4](#).

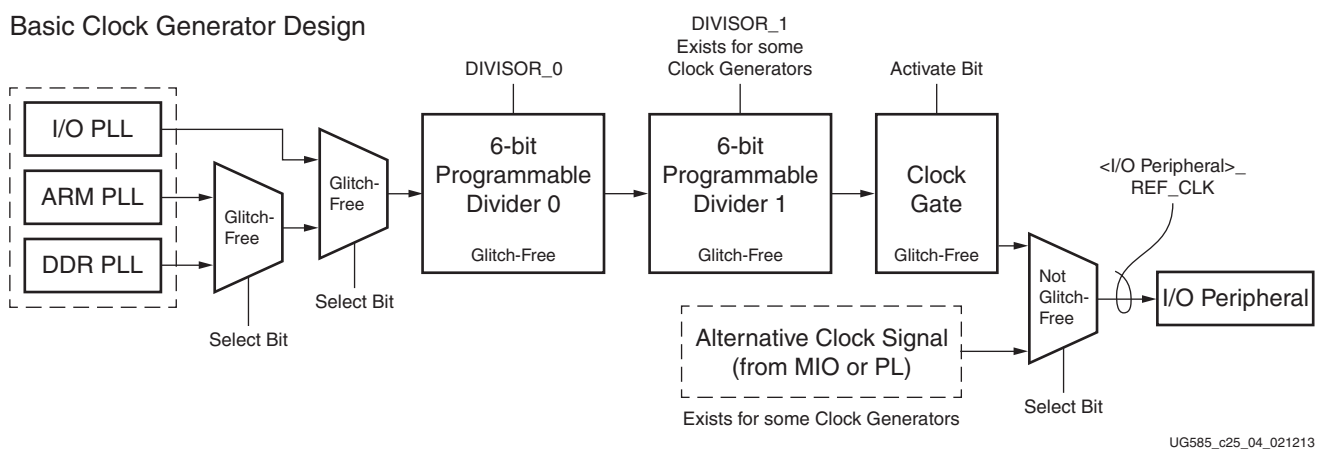

Figure 25-4: Basic Clock Branch Design

PLL

The PLL uses a feedback divider to create an output clock that is equal to the input reference clock multiplied by the PLL_FDIV value supplied by the SLCR.

Glitch-Free Clock Multiplexers

When a dynamic selection is required between two clock sources, the glitch-free multiplexers (GFM) change the clock selection on the low phase of the clock before starting the newly selected clock at the beginning of its low phase. The GFM operates properly only if both input clocks are active. Switching while either of the clocks is inactive causes the switching operation to fail.

Glitch-Free Divider

The glitch-free dividers take an input clock and divide it based on the divisor. When the divisor is changed, the output smoothly transitions to the new clock frequency without any glitches.

Glitch-Free Clock Gate

The glitch-free clock gate is used when a dynamic gating is required to enable and disable a clock source. The gate ensures that the clock is terminated and re-enabled cleanly on its low phase.

Clock Select Multiplexers

The clock source multiplexers select between the local clock generated by a clock generator and another source that is external to the clock generator. The clock source multiplexer is not glitch free.

25.5 DDR Clocks

There are two independent DDR clock domains: DDR_2x and DDR_3x. The DDR AXI interface, core, and PHY are all clocked by DDR_3x (see Figure 25-5). The AXI_HP ports and the AXI_HP interconnect paths from the AXI_HP to the DDR Interconnect module are clocked by DDR_2x.

These clocks are asynchronous to each other and can have a wide range of frequency ratios between them. The DIVISOR (DDR_CLK_CTRL[25:20]) for the DDR_3CLK must be an even value. The DIVISOR for DDR_2X can be any value.

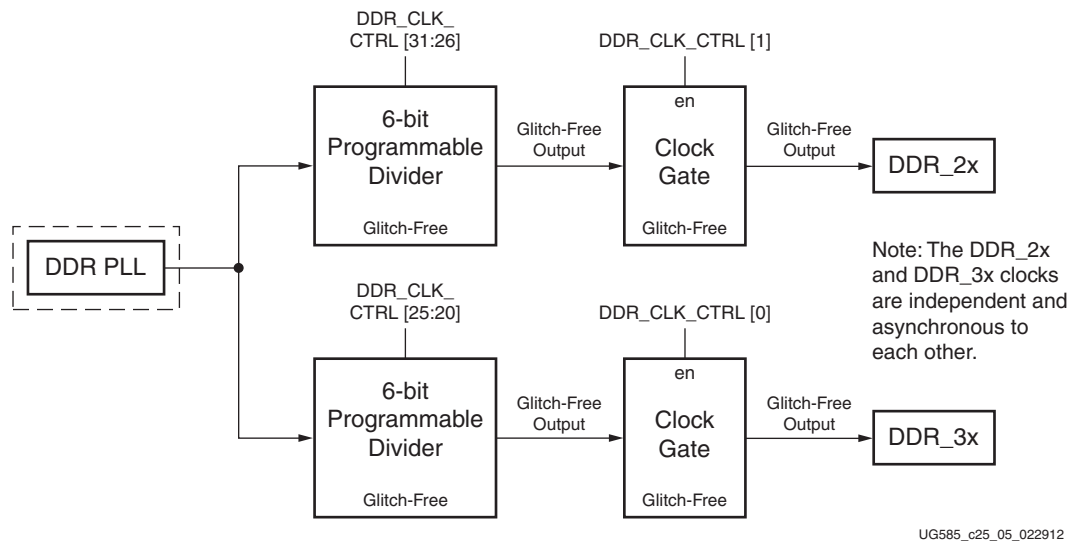

Figure 25-5: DDR Clock Generation

25.6 IOP Module Clocks

The IOP module clock (used for the internal controller logic) can be generated by the clock subsystem or, in some cases, the IOP's external interface. In all cases, the IOP's control and status registers are clocked by its AMBA interface clock (CPU_1x). Sometimes the CPU_1x clock is the only clock used by the IOP.

Each clock is discussed in more detail in the following sections and in the system functions section of each chapter.

- USB: ULPI PHY interface clock input on MIO.
- Ethernet: Clock generator or EMIO. For Rx, can be clocked by RGMII clock input on MIO.
- SDIO: Clock generator.
- SMC: Clock generator.
- SPI: Clock generator.
- Quad-SPI: clock generator.
- UART: Clock generator.
- CAN: Clock generator or MIO pin.
- GPIO: AMBA APB CPU_1x clock.
- I2C: AMBA APB CPU_1x clock and SCL interface clock.

25.6.1 USB Clocks

The USB controller module clock is generated externally and input on the ULPI PHY interface on MIO as shown in [Figure 25-6](#). USB clocks are described in [section 15.15.1 Clocks](#).

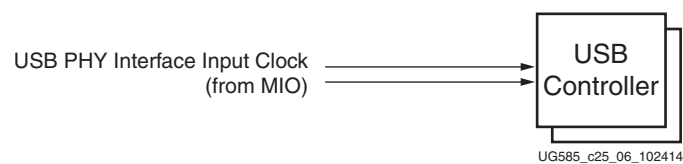

Figure 25-6: USB Clocks

25.6.2 Ethernet Clocks

The Ethernet Clocks generation network is shown in Figure 25-7.

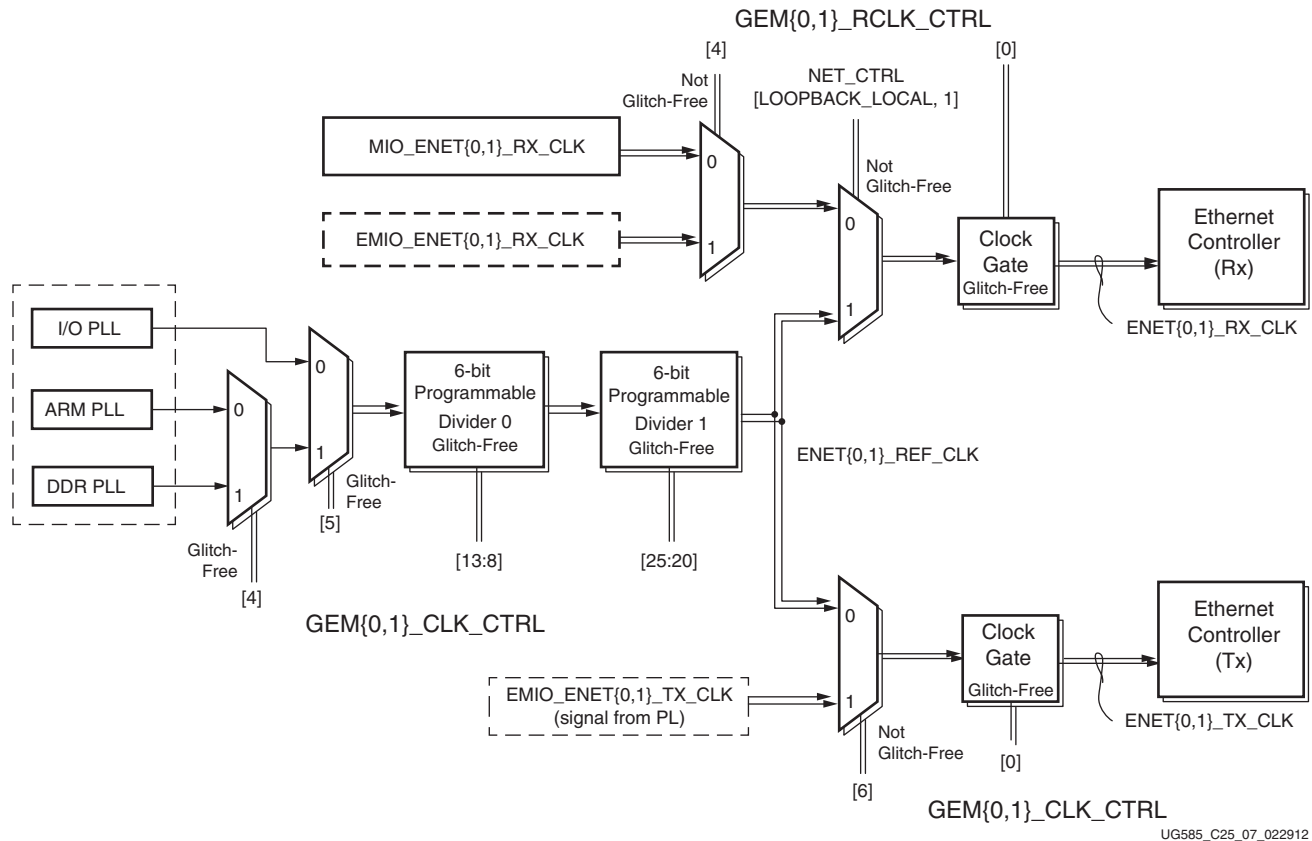

Figure 25-7: Ethernet Clock Generation

Ethernet Receiver Clocks

There are two Ethernet receiver clocks. In normal functional mode, these are either sourced from an external Ethernet PHY via the MIO or an extended MIO (EMIO). For MAC internal loopback mode, these clocks are sourced from the internal Ethernet reference clocks. They are also gated with an enable that can be used for power saving control. These are used to clock the receiver side of the Gigabit Ethernet MAC IP.

The source selection multiplexer and the loopback selection multiplexer are not glitch free because the source clocks might not be present. It is recommended that the clock be disabled before the multiplexers are changed. To support loopback mode, enet0_rx_clk and enet1_rx_clk are supplied with enet0_ref_clk and enet1_ref_clk.

Ethernet Transmit Clocks

Two Ethernet clocks are required to be generated: enet0_tx_clk and enet1_tx_clk. These are used to clock the transmit side of the Ethernet MACs and as a source synchronous output clock for the RGMII

interface. They are also used to provide a stable reference clock to the Ethernet receive paths when internal loopback mode is selected.

These clocks can also be sourced from the EMIO. In this case, the associated RGMII interface is disabled and the MAC connects to the PL through an MII or GMII interface. In this case, the Ethernet reference clock must be provided by the PL. This is regardless of MII or GMII, where normally tx_clk is an input in MII and an output in GMII.

When operating in MII or GMII mode, its reference clock is provided by the PL through the eth*_emio_tx_clk. The EMIO source multiplexer is not glitch free because the EMIO source clock cannot be relied upon to be present. It is anticipated that this source selection is a static configuration or that the generated clock be gated before changing to the EMIO source. To support loopback mode, gem0_rx_clk and gem1_rx_clk are supplied with gem0_ref_clk and gem1_ref_clk.

25.6.3 SDIO, SMC, SPI, Quad-SPI and UART Clocks

The SDIO, SMC, Quad SPI, and UART peripheral clocks all have the same programming model (see Figure 25-8). The PLL source and divider values are shared for each I/O peripheral controller. The clocks for each SDIO, SPI and the UART controller can be individually enabled/disabled. There is a single clock, each, for the SMC and Quad SPI controllers.

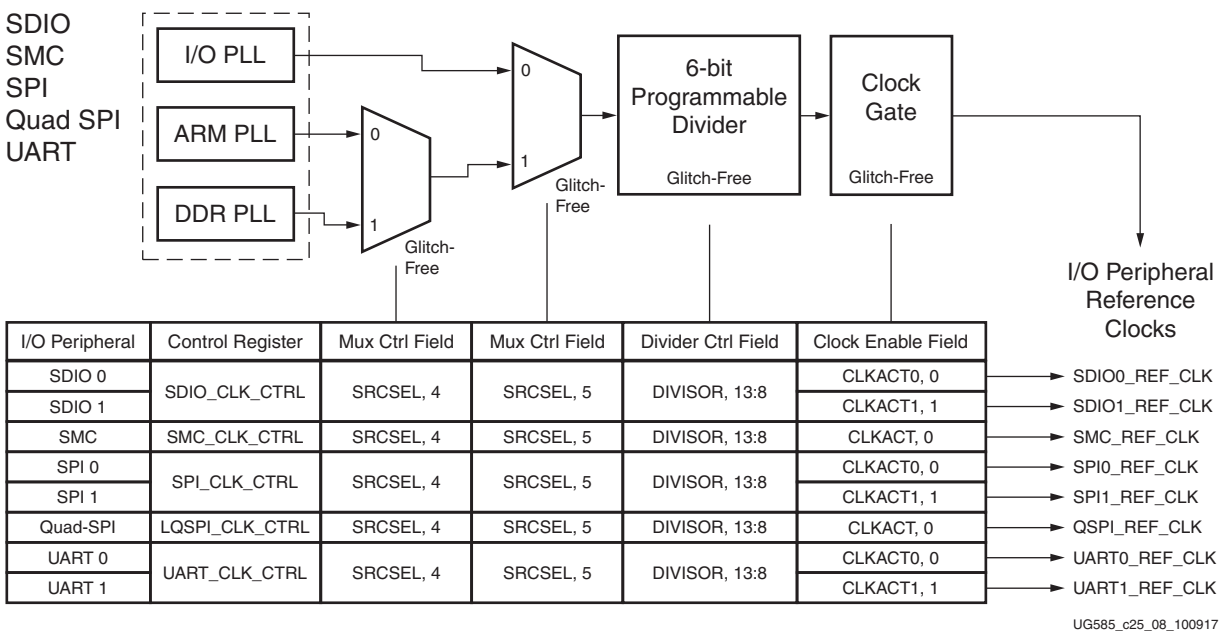
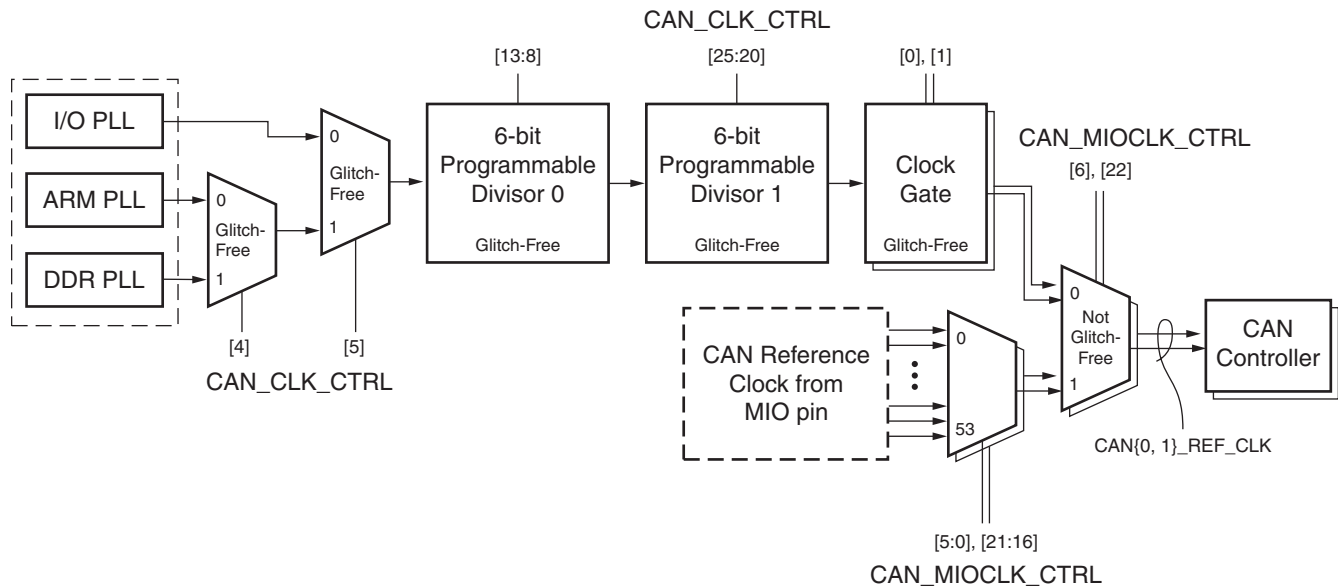

Figure 25-8: SDIO, SMC, SPI, Quad SPI and UART Reference Clocks

The Quad-SPI clock is divided down by at least two using the Quad-SPI baud rate divider, see section 12.4.1 Clocks. In master mode, the SPI clock is divided down by at least four using the SPI baud rate divider, see section 17.4.2 Clocks.

25.6.4 CAN Clocks

There are two controller area network (CAN) reference clocks: CAN0_REF_CLK and CAN1_REF_CLK. Both clocks share the same PLL source selection and dividers as shown in Figure 25-9. Each clock has independent alternate source selection (MIO pin or the clock generator), and independent clock gates. These clocks are used for the I/O interface side of the CAN peripherals.



UG585_c25_09_022912

Figure 25-9: CAN Clock Generation

25.6.5 GPIO and I2C Clocks

The GPIO and I2C peripherals are clocked by the CPU_1x APB bus interface clock provided by the interconnect (refer to section 25.2 CPU Clock).

25.7 PL Clocks

The PL has its own clock management generation and distribution features and also receives four clock signals from the clock generator in the PS (see Figure 25-10). For the details of the PL clocking structures, see the 7 series FPGAs clocking documentation.

The four clocks that are generated by the PS are completely asynchronous to each other with no relationship to other PL clocks.

The four clocks are derived from individually selected PLLs in the PS. Each of the PL clocks are independent output signals that produce suitable clock waveforms for PL use.

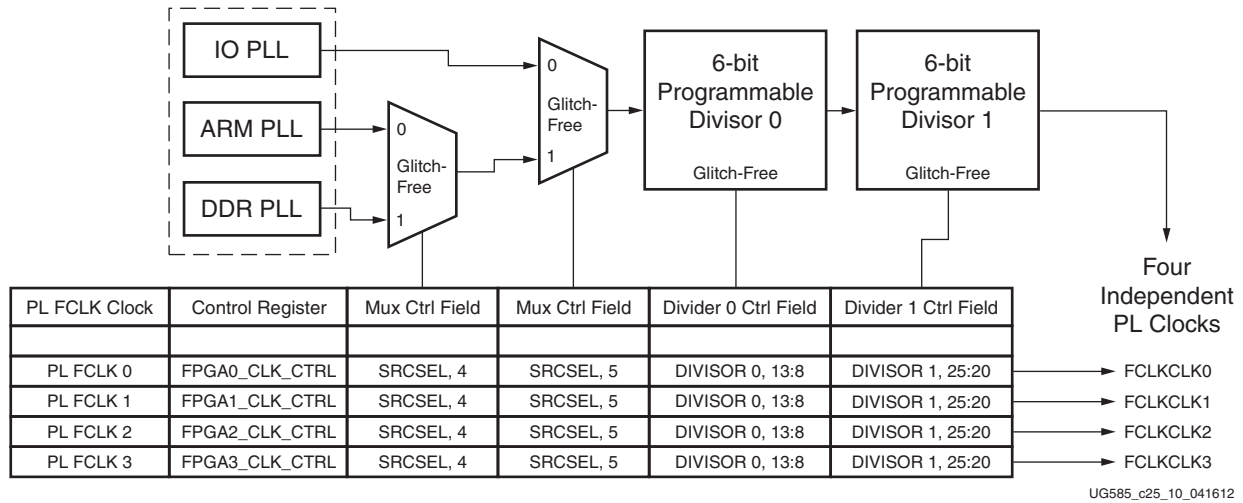

Figure 25-10: PL Clock Generation

25.7.1 Clock Throttle

Each of the four PL clocks includes logic to start and stop the clock and to assist with PL design debug and co-simulation. The clock throttle behavior is controlled by software and the trigger input signal from the PL. The clock throttle functions include:

- Start/stop clock under software control
- Run clock for a pre-programmed number of pulses
- Run clock and use PL logic to pause the clock pulses

Each clock throttle has a 16-bit counter that is programmed for the number of clock pulses to generate. For a continuous clock output, write a 0 to the counter, which is the default value. The current count can be read by software. The counting and clock pulses can be paused by the PL logic using the FCLKCLKTRIGxN input signal from the PL. The software can re-start the clocking by writing to the PL clock control register.

Table 25-4: PL Clock Throttle Input Signal

| Signal Name | I/O | Description |
|---------------|-----|--|
| FCLKCLKTRIGxN | I | The PL clock trigger signal is an input from the PL logic and is used to halt (pause) the PL clock when counting a programmed number of clock pulses. The halt mode is entered by the rising edge (logic 0 to logic 1) of the FCLKCLKTRIGxN signal. This signal can be asserted asynchronously to the FCLK and all other signals. This pin has no affect when the clock is running continuously, [LAST_CNT] = 0. |

Clock Controller States

The clock controller states are illustrated in Figure 25-11.

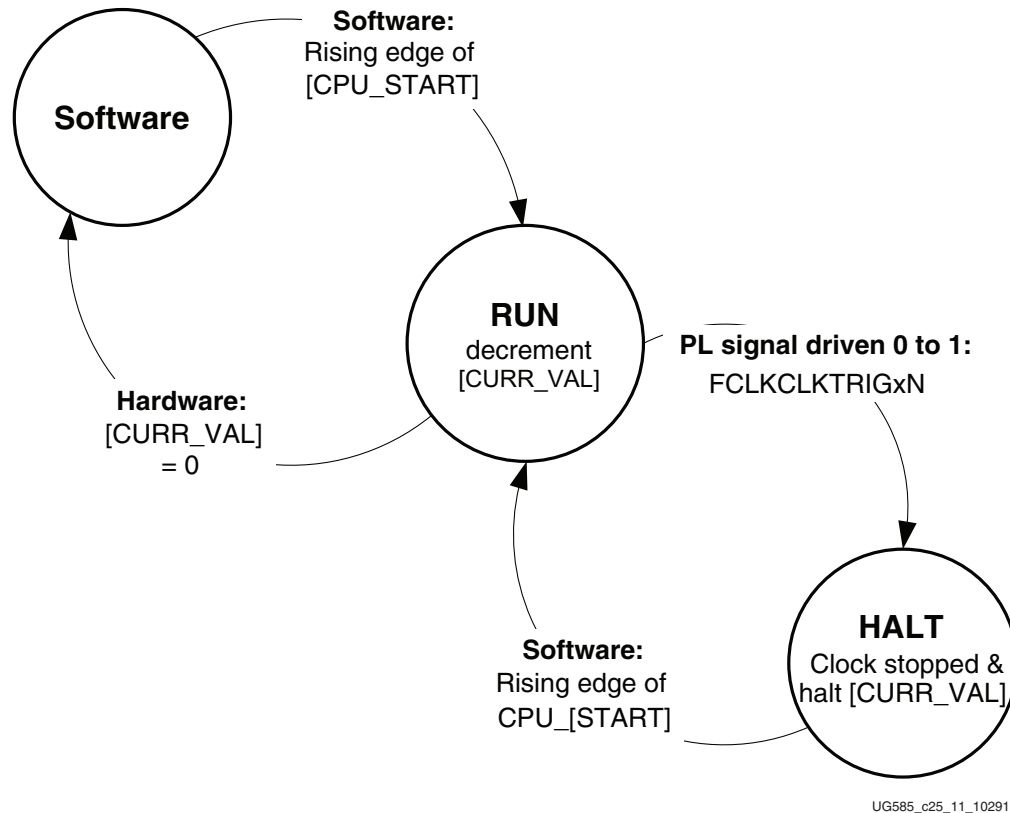

Figure 25-11: PL Clock Throttle States

25.7.2 Clock Throttle Programming

Example: Stop/Start Clock

This example illustrates a simple method to stop and start a PL clock (FCLKCLKx) using writes to the last count field in the throttle count register, `slcr.FPGAx_THR_CNT [LAST_CNT]`. The example assumes the `slcr.FPGAx_THR_CTRL` register is kept in its default state of `0x0000_0000`.

1. **Stop Clock:** Write `0x0000_0001` to `slcr.FPGAx_THR_CTRL` to immediately stop the clock.
 - `[LAST_CNT] = 1`
 - `[Reserved] = 0`
2. **Start Clock:** Write `0x0000_0000` to `slcr.FPGAx_THR_CTRL` to resume a continuous clock.
 - `[LAST_CNT] = 0`
 - `[Reserved] = 0`

Example: Run the PL Clock for 592 Pulses and Stop

In this example, there will be 592 clock pulses and stops. The `slcr.FPGAx_THR_CTRL` [CPU_START] bit is positive edge triggered to start the clock.

1. Prime the Start Clock bit: write `0x0000_0004` to the control register, `slcr.FPGAx_THR_CTRL`.
 - [CPU_START] = 0
 - [CNT_RST] = 0
 - [Reserved] = `0x001`
2. Program a count of 592: write `0x0000_0250` to the count register, `slcr.FPGAx_THR_CNT`.
 - [LAST_CNT] = `0x0250`
 - [Reserved] = 0
3. Assert the Start Clock bit: write `0x0000_0005` to the control register, `slcr.FPGAx_THR_CTRL`.
 - [CPU_START] = 1
 - [CNT_RST] = 0
 - [Reserved] = `0x001`

Example: Program 592 Pulses and Interact with the PL Trigger Input

In this example, there will be 592 clock pulses that are paused by the clock trigger signal (FCLKCLKTRIGxN) and re-started by software. The `slcr.FPGAx_THR_CTRL` [CPU_START] bit is positive edge triggered to start the clock.

1. **Prime the Start Clock bit:** See previous example.
2. **Program a count of 592:** See previous example.
3. **Assert the Start Clock bit:** See previous example.
4. **PL Logic Pauses the Clock (HALT state):** the logic asserts FCLKCLKTRIGxN input to stop the clock.
5. **Prime the Start Clock bit:** See previous example.

Assert the Start Clock bit: See previous example.

25.8 Trace Port Clock

The trace port clock is used to clock the TPIU and trace buffer when the MIO interface is chosen and must be twice the frequency of the desired TPIU clock. The TPIU clock frequency must be chosen to be fast enough to allow the trace port to keep up with the amount of data being traced, but slow enough to meet the dynamic characteristics of the data output buffers of the TPIU. To allow some flexibility, the trace clock is generated from a divided PLL output for MIO. When the trace port is routed through EMIO, the EMIOTRACECLK input is used to clock the TPIU as shown in Figure 25-12.

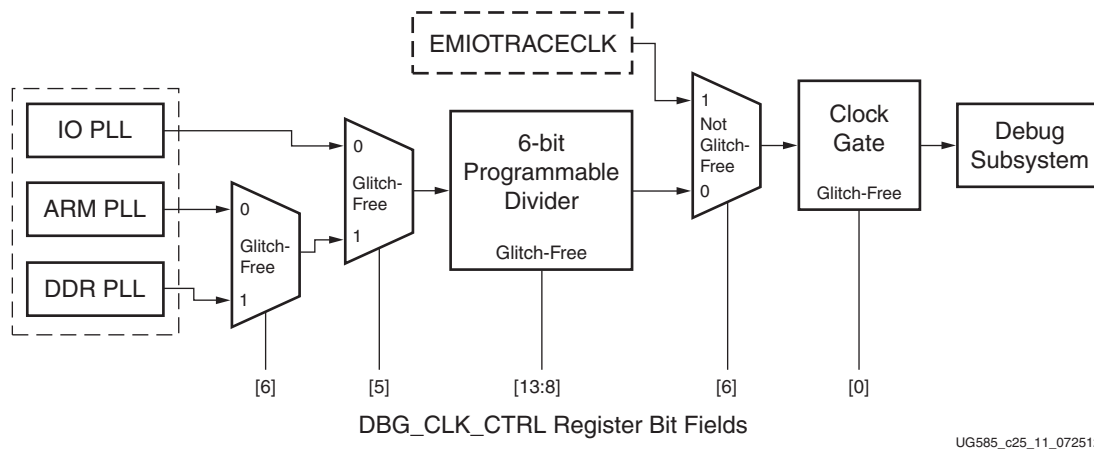

Figure 25-12: Trace Port Clock Generation

25.9 Register Overview

An overview of the PS clock subsystem registers is shown in Table 25-5.

Table 25-5: Clock Generation Register Overview

| Register | Description | Comments |
|---------------------------|-----------------------|--|
| PLL | | |
| PLL_STATUS | PLL status | |
| Arm_PLL_CTRL | CPU PLL control | <ul style="list-style-type: none"> Control registers include: <ul style="list-style-type: none"> Reset, power-down, bypass Divisor(s) Configuration registers include: <ul style="list-style-type: none"> PLL control parameters (see Table 25-6) |
| Arm_PLL_CFG | CPU PLL configuration | |
| DDR_PLL_CTRL | DDR PLL control | |
| DDR_PLL_CFG | DDR PLL configuration | |
| IO_PLL_CTRL | I/O PLL control | |
| IO_PLL_CFG | I/O PLL configuration | |
| CPU, DDR and Interconnect | | |
| Arm_CKL_CTRL | CPU clock control | |

Table 25-5: Clock Generation Register Overview (Cont'd)

| Register | Description | Comments |
|--------------------------------|--|---|
| CLK_621_TRUE | Select CPU clock frequency ratio | 6:2:1 or 4:2:1 |
| DDR_CLK_CTRL | DDR clock control | |
| APER_CLK_CTRL | AMBA peripheral clock control | |
| TOPSW_CLK_CTRL | Top-level switch clock control | |
| PL Clocks | | |
| FPGA{3:0}_CLK_CTRL | PS to PL output clock control | |
| FPGA{3:0}_THR_{CTRL, CNT, STA} | PS to PL output clock throttle control, count and status | |
| I/O Peripheral Clocks | | |
| GEM{1, 0}_RCLK_CTRL | Gigabit Ethernet Rx clock control | <ul style="list-style-type: none"> • DIVISOR bit field (one or two parameters, depending on the peripheral) • Clock enable active control |
| GEM{1, 0}_CLK_CTRL | Gigabit Ethernet ref clock control | |
| SMC_CLK_CTRL | SMC ref clock control | |
| LQSPI_CLK_CTRL | Quad-SPI ref clock control | |
| SDIO_CLK_CTRL | SDIO ref clock control | |
| UART_CLK_CTRL | UART ref clock control | |
| SPI_CLK_CTRL | SPI ref clock control | |
| CAN_CLK_CTRL | CAN ref clock control | |
| CAN_MIOCLK_CTRL | CAN comm port clock control | |
| System Debug Clocks | | |
| DBG_CLK_CTRL | CoreSight SoC trace clk control | |
| PCAP_CLK_CTRL | PCAP clock control | This controls the frequency and enable of the PCAP_2X clock for the DevC module. |

25.10 Programming Model

25.10.1 Branch Clock Generator

Each clock generator has a clock control register `<module>_CLK_CTRL`. Within the clock control register, the SRCSEL field selects a clock source and the DIVISOR field is the amount the source clock is divided down to produce the desired clock frequency. Some clock generators have two cascaded dividers.

To prevent the clock generator from exceeding the maximum frequency of the attached subsystem, program the SRCSEL and the DIVISOR values in three separate steps:

1. Increase the value of the DIVISOR, as needed, so that the two PLL clock sources will not cause the clock generator to exceed the maximum clock frequency of the subsystem.
2. Set the SRCSEL to the desired source.
3. Update the DIVISOR to the desired value.

6-bit Programmable Divider

The 6-bit divider provides a divide range of 1 to 63, supports both even and odd divide values producing a close to 50% duty cycle, and is glitchless (divide values can be modified dynamically). The two exceptions to this rule: the DDR_3X divider can only be programmed to divide by an even divisor, and the ARM_CLK_CTRL[DIVISOR] must be programmed with a value of 2 or greater when the PLL is being used. Some reference clocks have one divider and some have two dividers.

25.10.2 DDR Clocks



IMPORTANT: *It is a requirement that the DDR_3x clock must always be programmed to an even divisor.*



RECOMMENDED: *Changing the divider frequency does not produce glitches on the clock, however the DDR controller will not necessarily operate correctly if the frequency is changed without modifying its timing parameters. Therefore, it is suggested to first idle the DDR controller when the DDR clock is to be reprogrammed.*

25.10.3 Digitally Controlled Impedance (DCI) Clock

The digitally controlled impedance (DCI) clock is required by the DDR PHY for calibration. The DCI clock is a low frequency clock, normally set to 10 MHz.

25.10.4 PLLs

The three PLLs share the clock input signal, PS_CLK. Each PLL can be bypassed individually under software control. As part of the power-on reset sequence, all PLLs can be bypassed using the pll_bypass boot mode pin straps. (Refer to the boot mode section of [Chapter 6, Boot and Configuration](#).)

The PLL configuration and control registers are in the SLCR. The PLL frequency control registers include the M (feedback divide ratio also known as PLL_FDIV), LOCK_CNT, PLL_CP, and PLL_RES control fields. For each divide ratio M, the PLL_CP, PLL_RES, and LOCK_CNT fields must always be written with the values shown in [Table 25-6](#); the reset default values are not supported. After being enabled, the PLL will take some time to lock. The length of time is specified by the tLOCK_PSPLL data sheet parameter.

Enable PLL Mode when PLL Bypass Mode Pin is Tied High

After the system boots in bypass mode, the following sequence can be used to enable a PLL. Each PLL can be individually enabled. This example shows how to enable the Arm PLL:

1. Program the ARM_PLL_CTRL[PLL_FDIV] value and the PLL configuration register, ARM_PLL_CFG[LOCK_CNT, PLL_CP, PLL_RES], to their required values.
2. Force the PLL into bypass mode by writing a 1 to ARM_PLL_CTRL [PLL_BYPASS_FORCE, 4] and setting the ARM_PLL_CTRL [PLL_BYPASS_QUAL, 3] bit to a 0. This de-asserts the reset to the Arm PLL.
3. Assert and de-assert the PLL reset by writing a 1 and then a 0 to ARM_PLL_CTRL [PLL_RESET, 0].
4. Verify that the PLL is locked by reading PLL_STATUS [ARM_PLL_LOCK, 3].
5. Disable the PLL bypass mode by writing a 0 to ARM_PLL_CTRL [4].

The DDR and I/O PLLs are programmed in a similar fashion.

Software-Controlled PLL Update

The following steps are required for software to update the PLL clock frequency. This example is for the I/O PLL. [Table 25-6](#) shows the possible multiplier values and the required settings for each of those multiplier values.

1. Program the IO_PLL_CTRL[PLL_FDIV] value and the PLL configuration register, IO_PLL_CFG [LOCK_CNT, PLL_CP, PLL_RES].
2. Force the PLL into bypass mode by writing a 1 to IO_PLL_CTRL [PLL_BYPASS_FORCE, 4]. (When the PLL goes into reset in the next step, its output will be undefined.)
3. Assert and de-assert the PLL reset by writing 1 and then a 0 to IO_PLL_CTRL [PLL_RESET, 0]. (This is when the new values from step one are actually consumed by the PLL.)
4. Verify that the PLL is locked by reading PLL_STATUS [IO_PLL_LOCK, 2].
5. Disable the PLL bypass mode by writing a 0 to IO_PLL_CTRL [4].

Table 25-6: PLL Frequency Control Settings

| Desired PLL Multiplier | Required PLL Control and Configuration Bit Fields | | | |
|------------------------|---|--------|---------|----------|
| | PLL_FDIV | PLL CP | PLL RES | LOCK CNT |
| 13 | 13 | 2 | 6 | 750 |
| 14 | 14 | 2 | 6 | 700 |
| 15 | 15 | 2 | 6 | 650 |
| 16 | 16 | 2 | 10 | 625 |
| 17 | 17 | 2 | 10 | 575 |
| 18 | 18 | 2 | 10 | 550 |
| 19 | 19 | 2 | 10 | 525 |
| 20 | 20 | 2 | 12 | 500 |
| 21 | 21 | 2 | 12 | 475 |
| 22 | 22 | 2 | 12 | 450 |

Table 25-6: PLL Frequency Control Settings (Cont'd)

| Desired PLL Multiplier | Required PLL Control and Configuration Bit Fields | | | |
|------------------------|---|--------|---------|----------|
| | PLL_FDIV | PLL CP | PLL RES | LOCK CNT |
| 23 | 23 | 2 | 12 | 425 |
| 24 ~ 25 | 24 ~ 25 | 2 | 12 | 400 |
| 26 | 26 | 2 | 12 | 375 |
| 27 ~ 28 | 27 ~ 28 | 2 | 12 | 350 |
| 29 ~ 30 | 29 ~ 30 | 2 | 12 | 325 |
| 31 ~ 33 | 31 ~ 33 | 2 | 2 | 300 |
| 34 ~ 36 | 34 ~ 36 | 2 | 2 | 275 |
| 37 ~ 40 | 37 ~ 40 | 2 | 2 | 250 |
| 41 ~ 47 | 41 ~ 47 | 3 | 12 | 250 |
| 48 ~ 66 | 48 ~ 66 | 2 | 4 | 250 |

Reset System

26.1 Introduction

The reset system includes resets generated by hardware, watchdog timers, the JTAG controller, and software. Every module and system in Zynq-7000 SoC devices includes a reset that is driven by the reset system. Hardware resets are driven by the power-on reset signal (PS_POR_B) and the system reset signal (PS_SRST_B).

There are three watchdog timers in the PS that can generate resets. The JTAG controller can generate a reset that only resets the debug portion of the PS and a system-level reset. Software can generate individual sub-module resets or a system-level reset.

Resets are caused by many different sources and go to many different destinations. This chapter identifies all of the resets and either explains their functionality or provides a pointer to another chapter or another document.

26.1.1 Features

The key features of the reset system:

- Collects resets from hardware, watchdog timers, the JTAG controller and software
- Drives the reset of every module and subsystem
- Is an integral part of the device security system
- Executes a three-stage sequence: power-on, memory clear, and system enabling

26.1.2 Block Diagram

Figure 26-1 illustrates the logical dependencies of the main types of generated resets upon these reset triggers. This block diagram is intended to highlight dependencies, and does not accurately depict implementation detail or sequence timing.

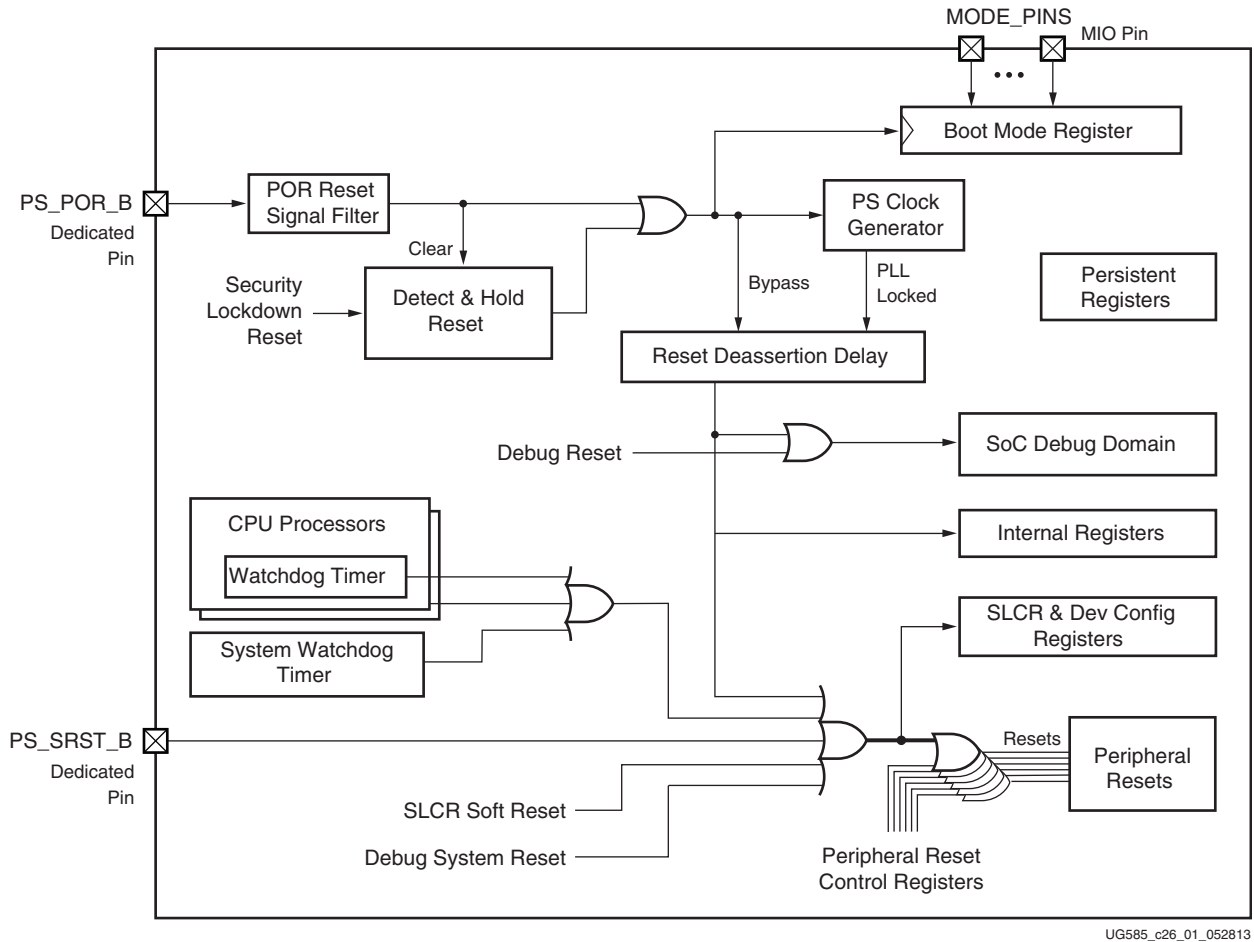
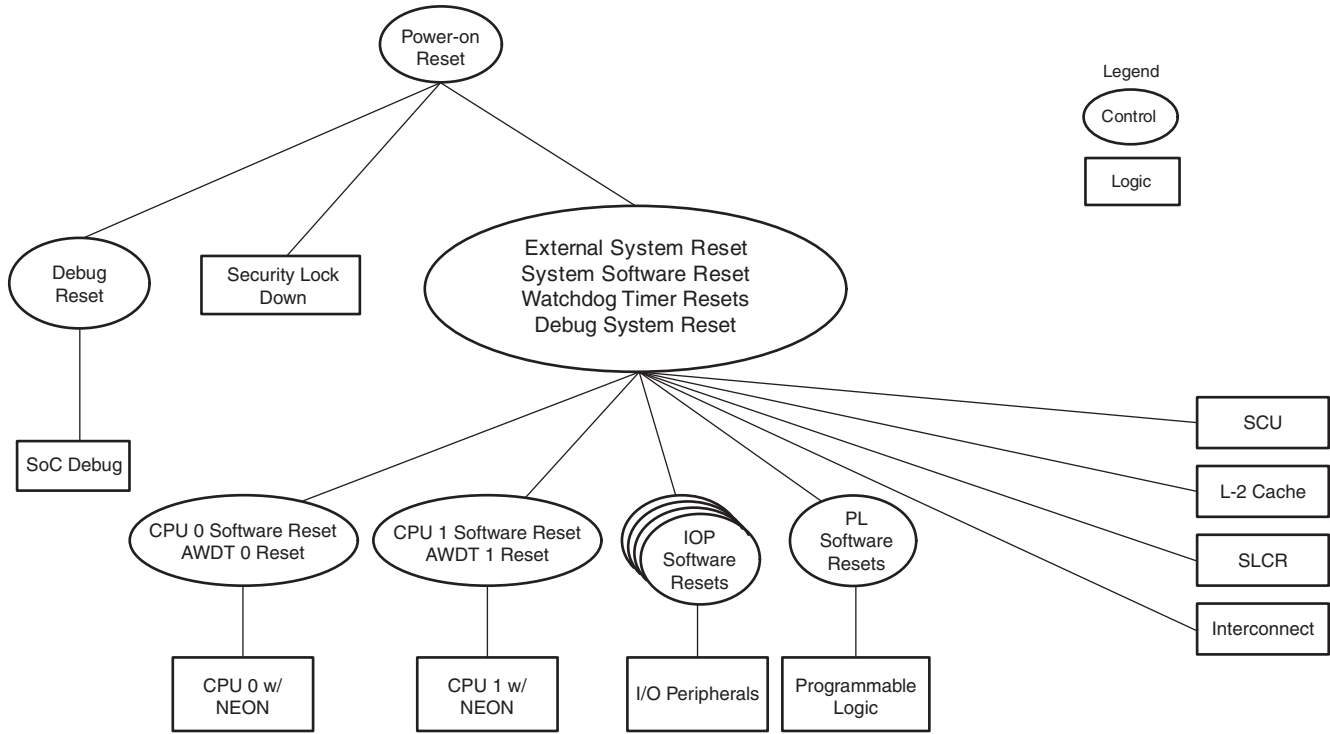

Figure 26-1: Resets Block Diagram

26.1.3 Reset Hierarchy

There are many different types of resets within the PS, from power-on reset that resets the entire system, to a peripheral reset which resets a single subsystem under software control. Figure 26-2 shows the relationships between all major reset signals within the PS. Reset signals flow from the top downwards. The rectangles at the end of the diagram represent the blocks that are reset. For example, power-on reset (POR) resets all logic within the PS, but system reset only resets the functions indicated in the diagram. This diagram presents the reset hierarchy of operation rather than the reset signal routing shown in Figure 26-1.



UG585_c26_02_101812

Figure 26-2: Reset Hierarchy Diagram

26.1.4 Boot Flow

The complete reset sequence is shown as in Figure 26-3. The first two steps are controlled by the external system and PS logic only starts to respond when power on reset (POR) is de-asserted. When the PS is operational, any type of reset can occur after POR. Those resets would insert into the flow chart, at their respective locations.

The POR signal can be asserted or de-asserted asynchronously. When the POR signal is de-asserted, it is conditioned to allow it to propagate cleanly to the clock module input logic and, if enabled, to the PLL clock circuits.

There is a BOOT_MODE strapping pin to select between all PLLs enabled and all PLLs disabled (bypassed). When the PLL is bypassed, the boot process takes longer.

After POR_N is released, the eFUSE controller comes out of reset. It automatically applies some data to the PLL and provides redundancy information to some of the RAMs in the PS. This activity is not visible to the user and cannot be affected by the user. This activity requires from 50 us to 100 us of time to complete.

If the PLLs are enabled, then the POR signal is delayed at this point until the PLL clocks have locked. If PLL bypass mode is selected, the POR signal is not delayed.

Before the BootROM starts executing, the internal RAMs are cleared by hardware writing zeros into all addresses. For a listing of the times it takes to go through these steps, see section 6.3.3 BootROM Performance in Chapter 6, Boot and Configuration.

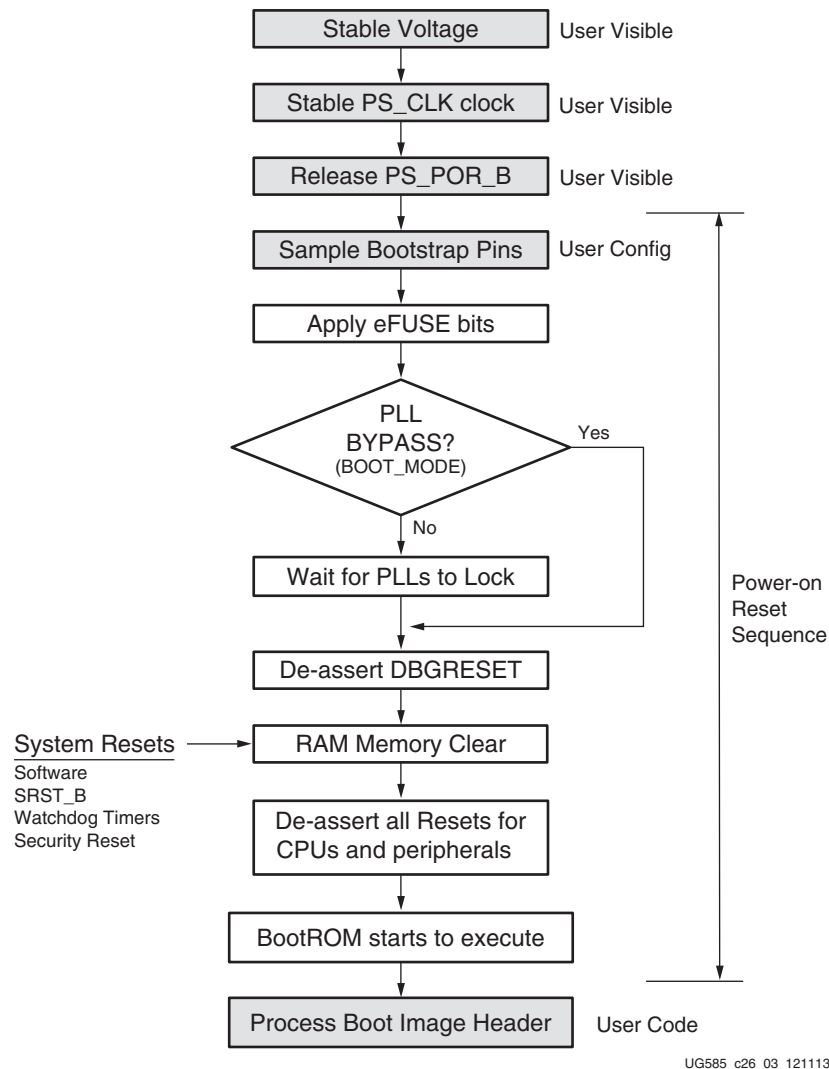

Figure 26-3: Power-On Reset Flow Diagram

26.2 Reset Sources

26.2.1 Power-on Reset (PS_POR_B)

The PS supports external power-on reset signals. The power-on reset is the master reset of the entire chip. This signal resets every register in the device capable of being reset. While PS_POR_B is held Low, all PS I/Os are held in 3-state and a weak pull-up is enabled on most MIO pins. The pull-up for each MIO pin is independently controlled by the MIO_PIN_xx [PULLUP] bit. The reset value of bit 12 can be read in the SLCR register summary table.

The PS_POR_B reset pin is held Low until all PS power supplies are at their required voltage levels and PS_CLK is active. It can be asynchronously asserted and is internally synchronized and filtered. The

filter prevents High-going glitches from entering the PS while the signal is intended to be held Low. It does not filter Low-going glitches when the signal is intended to be held high. Any Low-going glitch that is detected causes an immediate reset of the device.

The PS_POR_B signal is often connected to the power-good signal from the power supply. When PS_POR_B is de-asserted, the system samples the boot strap mode pins and begins its internal initialization process.

26.2.2 External System Reset (PS_SRST_B)

Power-on reset erases all debug configurations. The external system reset allows the user to reset all of the functional logic within the device without disturbing the debug environment. For example, the previous break points set by the user remain valid after the external system reset. While PS_SRST_B is held Low, all PS I/Os are held in 3-state.

Due to security concerns, system reset erases all memory content within the PS, including the OCM. The PL is also reset in system reset. System reset does not re-sample the boot mode strapping pins.

If this pin is not used in the system, it should be tied high.

26.2.3 System Software Reset

The user can reset the entire system by asserting a software reset. By asserting PSS_RST_CTRL[SOFT_RST], the entire system is reset with the same end result as the user pressing the PS_SRST_B pin (other than the REBOOT_STATUS register value being different).

Just like the other system resets, all of the RAMs are cleared and the PL is reset as well.

26.2.4 Watchdog Timer Resets

The watchdog timer resets are internally generated by the watchdog timers when they are enabled and the timer expires. There are three different watchdog timers in the PS: one system-level timer (SWDT) and one private timer in each of the two Arm cores (AWDT0 and AWDT1). The system-level timer reset signal always resets the entire system, while the private watchdog timers can either reset just the Arm core where it is housed, or the entire system.

26.2.5 Secure Violation Lock Down

When a security violation is detected, the entire PS is reset and locked down. After a security lock down occurs, the PS only becomes active again by asserting and de-asserting the PS_POR_B reset pin. Refer to [Chapter 32, Device Secure Boot](#) for details of how and when this signal is asserted.

26.2.6 Debug Resets

There are two types of debug resets that originate from the debug access port (DAP) controller; debug system reset and debug reset.

Debug system reset is a command from the Arm DAP which is controlled by JTAG. This causes the system to reset, just like the external system reset.

Debug reset resets certain portions of the SoC debug block including the JTAG logic.

The PS does not support the external TRST, although it does support assertion of a reset sequence using TMS. The JTAG logic is only reset at power-on reset or assertion of CDBG_RSTREQ from the Arm debug access port (DAP) Controller (JTAG). All of the logic in the JTAG TCK clock domain is reset by this signal.

26.3 Reset Effects

The effects of various resets are described in [Table 26-1](#).

Table 26-1: Reset Effects

| Reset Name | Source | Portion of System that is Reset | RAMs Cleared | slcr.REBOOT_STATUS Bits set = 1 |
|---|------------|---|--------------|---------------------------------|
| Power-On Reset (PS_POR_B) | Device pin | Entire chip, including debug (All) The PL must be re-programmed. | All | [POR] |
| Security Lock Down (requires a power-on reset to recover) | DevC | | All | N/A |
| External System Reset (PS_SRST_B) | Device pin | All except debug and persistent registers. The PL must be re-programmed. | All | [SRST_RST] |
| System Software | SLCR | | All | [SLC_RST] |
| System Debug Reset | JTAG | | All | [DBG_RST] |
| System Watchdog Timer | SWDT | | All | [SWDT_RST] |
| CPU0 and CPU1 Watchdog Timers (when slcr.RS_AWDT_CTRL{1,0} = 0) | AWDT | | All | [AWDT{1,0}_RST] |
| CPU0 and CPU1 Watchdog Timers (when slcr.RS_AWDT_CTRL{1,0} = 1) | AWDT | CPU (s) only. | None | N/A |
| Debug Reset | JTAG | Debug logic. | None | N/A |
| Peripherals | SLCR | Selected peripherals or CPUs. | None | N/A |

26.3.1 Peripherals

All PS peripherals are reset when the PS is reset. In addition, individual peripheral resets might also be asserted under software control, through programmable bits within the SLCR.

Most peripherals have the ability to reset each of the clock domains within that peripheral. For instance, the Ethernet controller can reset the RX side, TX side, or the interconnect side. Each clock domain can be reset separately. Individual peripherals might have their own resets defined within those blocks.

Peripheral resets do not result in the RAM memory clear logic being activated to clear all memories within the design.

26.4 PL Resets

26.4.1 PL General Purpose User Resets

There are four separate reset signals, FCLKRESETN[3:0], routed to the PL which could be used as general purpose reset signals for PL logic. These reset signals are not removed until the PS is out of its boot sequence and user code de-asserts them. They are controllable by the slcr.FPGA_RST_CTRL register. SLCR.FPGA_RST_CTRL. PL logic connecting to the PS must not be reset when active bus transactions exist, since uncompleted transactions could be left pending in the PS.

The reset signal is loosely associated with the FCLK of the same number, however, the timing is such that it must be considered an asynchronous reset to the PL. If the user requires a synchronized reset, the user must synchronize it themselves in the PL. (The FCLK needs to be toggling for the reset to propagate out of the PS.)

26.5 Register Overview

The following sections provide an overview of the reset control registers.

26.5.1 Persistent Registers

All registers are reset when the PS_POR_B reset signal is asserted. There are several registers and register bits that persist through a non-POR reset (PS_SRST, watchdog, etc.). The persistent registers are listed in [Table 26-2](#).

Note: POR required to unlock slcr.SCL [LOCK] register bit, affecting: SCL, PSS_RST_CTRL, APU_CTRL, and WDT_CLK_SEL.

Table 26-2: Persistent Register and Register Bits

| Type | Name |
|---------------|---|
| Registers | devcfg.LOCK devcfg.MULTIBOOT_ADDR ⁽¹⁾ devcfg.UNLOCK scu.Watchdog_Reset_Status_Register slcr.REBOOT_STATUS |
| Register bits | devcfg.CTRL [PCFG_AES_EN] devcfg.CTRL [PCFG_AES_FUSE] devcfg.CTRL [SEC_EN] devcfg.CTRL [SEU_EN] devcfg.STATUS [ILLEGAL_APB_ACCESS] devcfg.STATUS [SECURE_RST] slcr.APU_CTRL [CFGSDISABLE] slcr.APU_CTRL [CP15SDISABLE] slcr.ARM_CLK_CTRL [SRCSEL] |

Notes:

1. The upper 16 bits of the devcfg.MULTIBOOT_ADDR register, [31:16], are available to store data that remain persistent through a non-POR reset.

26.5.2 System Reset Control

System Reset registers are identified in [Table 26-3](#).

Table 26-3: System Reset Control

| Name | Systems Affected | HW Register Name |
|-----------------------|------------------|-------------------|
| System Software Reset | All | slcr.PSS_RST_CTRL |

26.5.3 Peripheral Reset Control

The reset domains and register bits are identified in [Table 26-4](#). Resetting the AXI interconnect causes the system to no longer be accessible. Resetting other parts of the system might cause undesirable results. Reset a peripheral only when that part of the system is quiescent.

Table 26-4: Peripheral Reset Control Registers Overview

| Peripheral Name | Description | HW Register |
|------------------|--|--------------------------------|
| AXI Interconnect | Central, Master, Slave, and OCM Switches | slcr.TOPSW_RST_CTRL |
| CPU 0 | CPU 0 | slcr.A9_CPU_RST_CTRL [A9_RST0] |
| CPU 1 | CPU 1 | slcr.A9_CPU_RST_CTRL [A9_RST1] |
| CPU Peripherals | AWDT/Timers/GIC | slcr.A9_CPU_RST_CTRL [PER_RST] |
| SCU, L2-cache | Snoop Control, L2-cache | System reset (POR or non-POR) |
| OCM | On chip memory | slcr.OCM_RST_CTRL |
| CAN | CPU 1x | slcr.CAN_RST_CTRL |

Table 26-4: Peripheral Reset Control Registers Overview (Cont'd)

| Peripheral Name | Description | HW Register |
|-----------------|--------------------------------------|---------------------|
| DDR | DDR PHY/controller/control registers | slcr.DDR_RST_CTRL |
| DMA | DMA interface | slcr.DMAC_RST_CTRL |
| Ethernet | Ref, Rx and CPU 1x | slcr.GEM_RST_CTRL |
| PS-PL | General purpose PL resets | slcr.FPGA_RST_CTRL |
| GPIO | CPU 1x | slcr.GPIO_RST_CTRL |
| I2C | CPU 1x | slcr.I2C_RST_CTRL |
| Quad-SPI | Ref and CPU 1x | slcr.LQSPI_RST_CTRL |
| SDIO | Ref and CPU 1x | slcr.SDIO_RST_CTRL |
| SPI | Ref and CPU 1x | slcr.SPI_RST_CTRL |
| SMC | Ref and CPU 1x | slcr.SMC_RST_CTRL |
| UART | Ref and CPU 1x | slcr.UART_RST_CTRL |
| USB | ULPI and CPU 1x | slcr.USB_RST_CTRL |

JTAG and DAP Subsystem

27.1 Introduction

The Zynq-7000 family of SoC devices provides debug access via a standard JTAG (IEEE 1149.1) debug interface. Internally, the SoC device implements both an Arm debug access port (DAP) inside the Processing System (PS) as well as a standard JTAG test access port (TAP) controller inside the Programmable Logic (PL). The Arm DAP as part of Arm CoreSight debug architecture allows the user to leverage industry standard third-party debug tools.

In addition to the standard JTAG functionality, the Xilinx TAP controller supports a number of PL features including PL Debug, eFuse/BBRAM programming, on-chip XADC access, etc. Most importantly, it also allows debugging of Arm software through the DAP and PL hardware by using the TAP simultaneously with a trace buffer and cross triggering interface between the PS and PL.

Another important debug feature the Zynq-7000 SoC includes is debug trace support. This feature allows the user to capture both the PS and PL trace into a common trace buffer that is either read out through JTAG, described below, or sent out through the trace port interface unit (TPIU), described in [Chapter 28, System Test and Debug](#).

27.1.1 Block Diagram

[Figure 27-1](#) shows the top level DAP/TAP architecture. As soon as the BootROM passes control to user software, the JTAG chain is enabled automatically, assuming a non-secure boot process. This allows debugging from the user software entry point.

JTAG supports two different modes: cascaded JTAG mode (also referred to as single chain mode) and independent JTAG mode (also referred to as split chain mode). The mode is determined through the mode input when the system comes out of reset.

In cascaded JTAG chain mode, both the TAP and DAP are visible from external JTAG debug tools or a JTAG tester. With dedicated PL_TDO/TMS/TCK/TDI I/O at the PL side, only one JTAG cable can be connected, though it has access both to PS and PL features concurrently.

To debug Arm software and the PL design simultaneously with separate cables, the user must switch to independent JTAG mode. In this mode, JTAG cables only see the Xilinx TAP controller from the dedicated PL_TDO/TMS/TCK/TDI pins. To debug Arm software, the user can route the Arm DAP signals (PJTAG) through the MIO or through the EMIO and to PL SelectIO pins.

It is important to note that both the PS and PL must be powered on to use JTAG debug. Due to security reasons, the JTAG chain is protected with triple redundancy gating logic to prevent

accidental debug enablement under the security environment due to a single event upset (SEU). Zynq-7000 SoC devices also provide JTAG disable lock-down to prevent debug enablement due to software errors.

The Zynq-7000 SoC provides for permanently disabling JTAG, by using one eFuse bit to record. Care should be used when selecting this option because the eFuse JTAG disable is not reversible.

Figure 27-2 shows the debug trace architecture. The user can enable debug trace source, PTM, ITM, and FTM using either the JTAG/DAP interface or software through the debug APB bus.

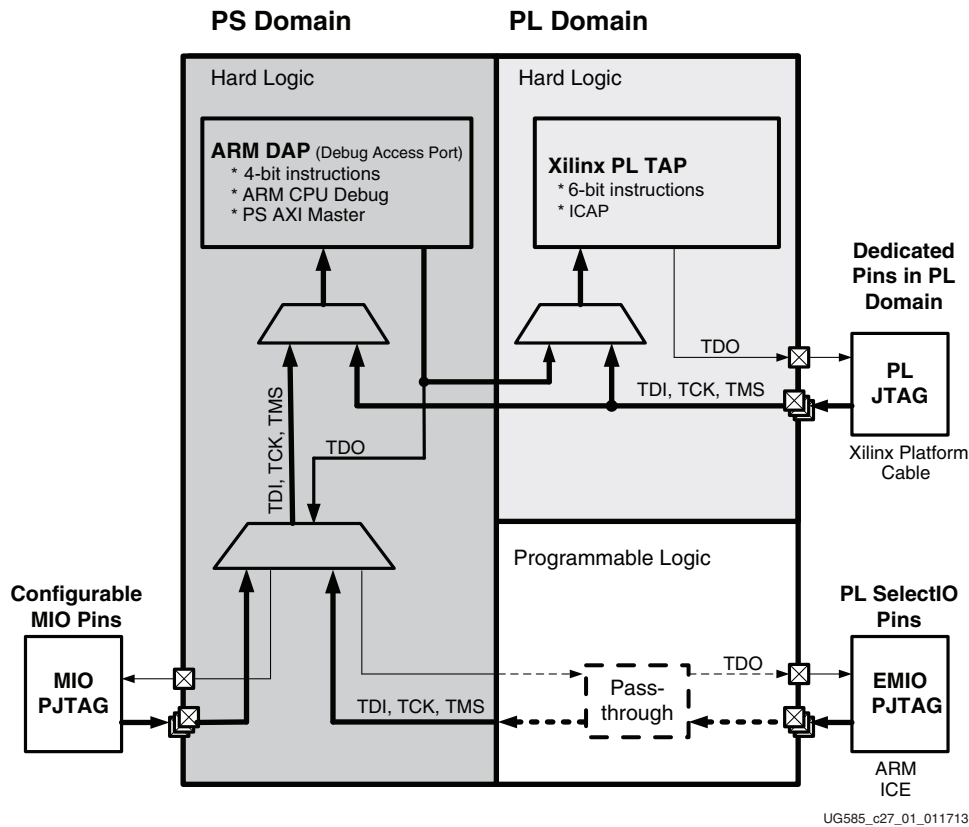
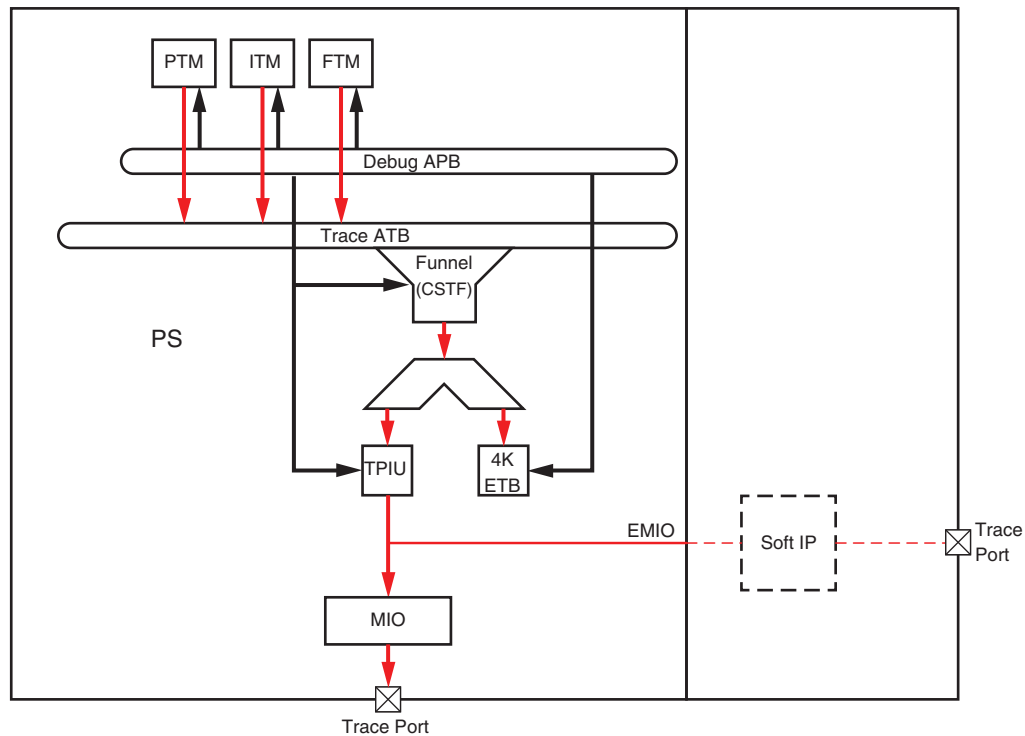

Figure 27-1: JTAG System Block Diagram

This section focuses on the trace port interface unit, which is one of the trace sink modules used to dump real-time trace to an external trace capture module. Both TPIU and ETB receive exact same copies of aggregated trace from multiple trace sources.

Although ETB is able to support high trace bandwidth, the 4 KB limit only allows capturing the trace in a small time window. To monitor trace information over a longer period of time, the user must enable the TPIU to dump either through MIO or EMIO so the trace is captured by external trace capture equipment such as an HP logic analyzer, Lauterbach Trace32, Arm DStream, etc.



UG585_c27_02_050212

Figure 27-2: Debug Trace Port

27.1.2 Features

Key features of the JTAG debug interface are:

- JTAG 1149.1 boundary scan support
- Two 1149.1 compliance TAP controllers: One JTAG TAP controller and one Arm DAP
- Single unique IDCODE from the Xilinx TAP for each of the Zynq 7000 family of devices
- IEEE 1532 programming in-system-configurable (ISC) devices support
 - eFuse programming
 - BBRAM programming
 - XADC access
- On-board flash programming
- Xilinx chipscope debug support
- Arm CoreSight debug center control using Arm DAP
- Indirect PS address space access through DAP-AP port
- External trace capture using MIO in PS, or EMIO in PL

27.2 Functional Description

Figure 27-3 shows the Arm DAP and JTAG TAP controllers connected in daisy-chain order with the Arm DAP at the front of chain. The two JTAG controllers belong to two different power domains. The Arm DAP is in the PS power domain while the TAP is in the PL power domain. JTAG I/O pads are located in the PL power domain to take advantage of existing JTAG I/O pads in the PL. Although the PS supports PL power down mode, both power domains must be powered on to support all JTAG related features.

The Arm DAP controller has a 4-bit IR length and the TAP controller has a 6-bit IR length. The two controllers operate completely independently. The user can access the TAP and Arm DAP controller simultaneously in independent mode. Due to security reasons, the Arm DAP controller is bypassed when the PS is out of reset. The Xilinx TAP controller within the PL can be disabled through the eFuse or the control register within the PL configuration logic.

All debug components within the PS are under direct control of the debug tools, such as Arm RVDS or Xilinx XDK, through Arm DAP. All debug components (including DAP) within the PS are designed and integrated following Arm CoreSight architecture. Although there is no CoreSight component within the PL, FTM components within the PS allows a PL trace to be dumped into the ETB. CTI/CTM supports cross triggering between the PS and PL.

As shown in Figure 27-3, all PS debug components are tied to the debug APB bus with the DAP as the only bus master. External debug tools connected to the Arm DAP through JTAG uses the debug APB bus to configure all debug components including CPU, CTI/CTM, PTM, ITM, and FTM. Debug APB is also used to extract trace data from the ETB. It is a complicated process to configure all of the debug components properly to support user debug needs. Fortunately, most of the work is automatically handled by the debug tools. However, understanding Zynq debug architecture is necessary to better utilize the full system debug capability.

Other than debug control, the Arm DAP also acts as master device within the system interconnect. In previous debug systems, it was required to halt the CPU in order to probe system address space. This new arrangement allows the user to access system address space without halting the CPU. (See Chapter 28, System Test and Debug for more information).

The PL Xilinx TAP controller serves four key purposes: boundary scan test, eFuse programming, BBRAM programming, and PL debug chipscope.

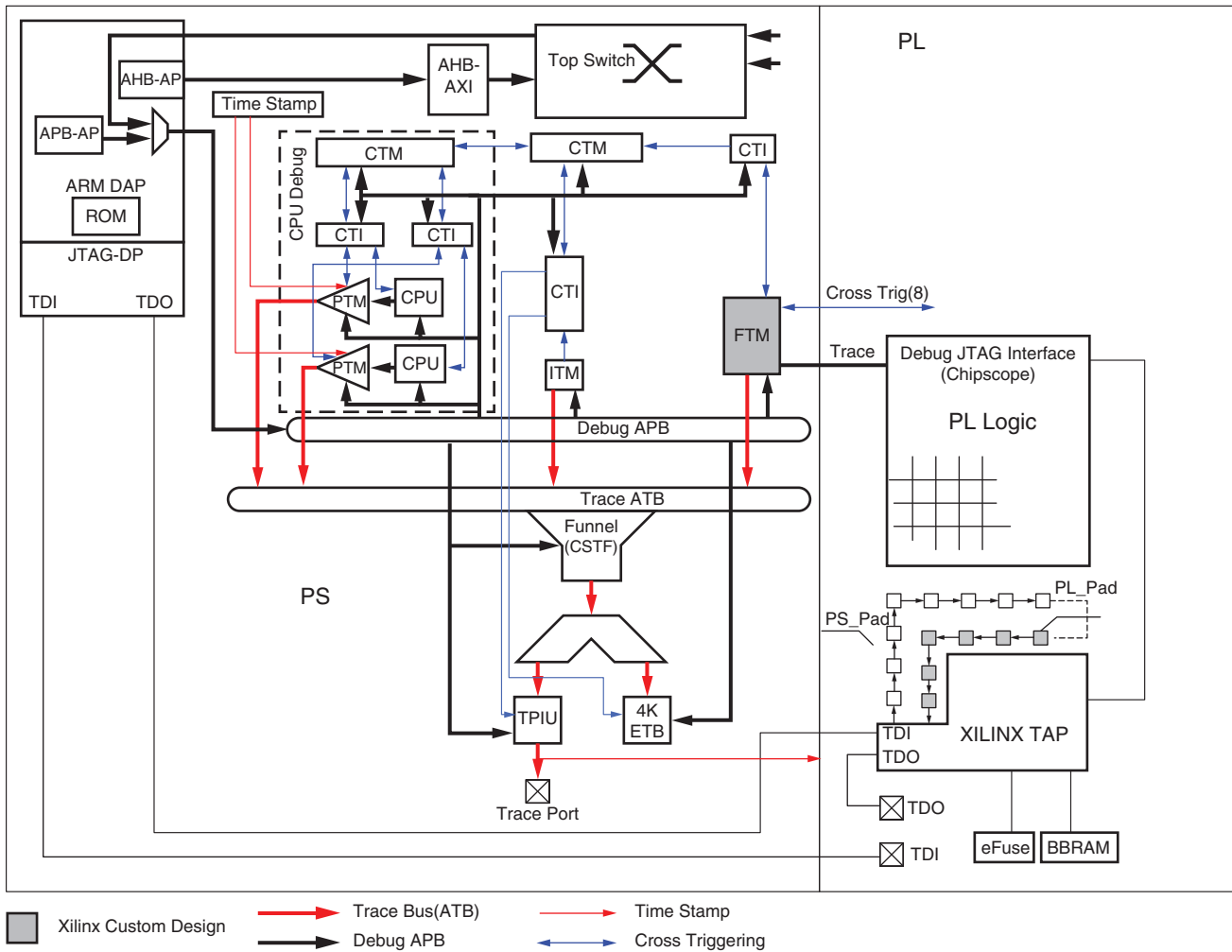

UG585_c27_03_021313

Figure 27-3: Debug System Architecture

The TPIU provides the mechanism to capture trace over long periods of time. There is no internal time limit to how long a trace can be dumped so the only practical limit is the Zynq-7000 bandwidth. If doing a trace dump using PS I/O through MIO, the maximum trace bandwidth depends on how many MIO trace I/Os could be allocated. Another alternative is trace dump through EMIO. PL soft logic connects the EMIO trace signal to the PL SelectIO. There are other potential innovative ways to handle EMIO trace.

For example, users could loopback EMIO trace data back to the PS and store it in DDR memory or export trace via gigabit Ethernet to enable remote debug or monitor. In typical debug flow, the user enables minimum trace source dumping capability to fit trace data into allocated TPIU throughput. After a small time window when debug occurs as determined through trace monitoring, the user could enable full trace dumping capability if required, and store short periods of data into the ETB for the next level of debug. Other than debugging, trace port also brings significant value for software profiling. Soft profiling helps the user to identify those software routines that consume the

most CPU power. Based on that, the user could decide to either perform software optimization or offload the process to the PL.

27.3 I/O Signals

In cascaded JTAG mode, only PL_TDO/TMS/TCK/TDI at the PL side are meaningful to users. Through them, users can access both the Arm DAP and Xilinx TAP.

In independent JTAG mode, users can only access the Xilinx TAP, through PL_TDO/TMS/TCK/TDI. To access the Arm DAP, users must use PJTAG signals, as shown in [Table 27-1](#). There are two choices to route PJTAG signals to chip pinouts: via EMIO to the PL SelectIO, or via MIO.

The MIO pins and any restrictions based on device version are shown in the MIO table in section [2.5.4 MIO-at-a-Glance Table](#).

Table 27-1: PJTAG Signals

| Signal Name | via EMIO | | via MIO | |
|-------------|--------------|-----|----------------------|-----|
| | Signal | I/O | Pin | I/O |
| TCK | EMIOPJTAGTCK | I | MIO 12, 24, 36 or 48 | I |
| TMS | EMIOPJTAGTMS | I | MIO 13, 25, 37 or 49 | I |
| TDI | EMIOPJTAGTDI | I | MIO 10, 22, 34 or 46 | I |
| TDO | EMIOPJTAGTDO | O | MIO 11, 23, 35 or 47 | O |
| TDO 3-state | EMIOPJTAGDTN | O | | |

The TPIU output, as shown at the bottom of [Figure 27-3](#), can be routed to either EMIO or MIO (but not both). The TPIU signals are listed in section [28.3 I/O Signals](#).

27.4 Programming Model

27.4.1 Use Case I: Software Debug with Trace Port Enabled

This is the normal debug case for most applications. [Figure 27-4](#) shows Arm tool chain solution. It is also possible to replace Arm Real View ICE with a Xilinx or Lauterbach debug tool. In this case, there is no PL programming required and the user is able to start on software debug as soon as chip power is on. In this use case, the DAP is active to support software debug needs but the TAP is put into bypass mode. Trace port is also enabled through the MIO pin. Although bandwidth might be limited due to limited MIO availability in some cases, the user could enable a trace dump without depending on PL configuration in this configuration. The major challenge for most users is to allocate MIO pins for the Trace port.

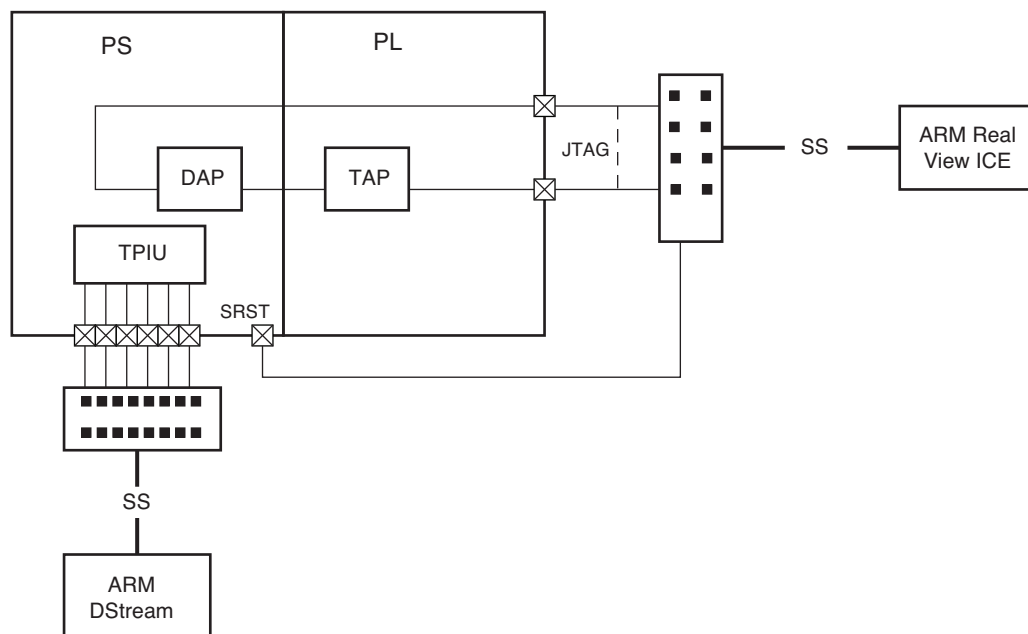

UG585_c27_04_031812

Figure 27-4: User Case I: Software Debug with Trace Port Enabled

27.4.2 Use Case II: PS and PL Debug with Trace Port Enabled

The second use case shows how to enable PS software and PL hardware at the same time with two separate debug tools. The tool connected to the Xilinx TAP is typically a Xilinx debug tool. The tools connected to the PS DAP could be Xilinx or any third-party debug tools from Arm or Lauterbach.

To support this mode, PL configuration is required to bring the DAP JTAG signals to the PL SelectIOs. [Figure 27-5](#) shows trace port access through the PL SelectIO, but the user could use the MIO trace port as in the previous use case if there is way to manage to fit the trace port into the limited MIO pin multiplexing. Trace port access through SelectIO could support up to 32-bit trace data and gives users enough trace port throughput to address most debug need. As with the JTAG DAP access, the

PL must be configured to route the trace signal from the EMIO at the PS/PL boundary to the PL SelectIO.

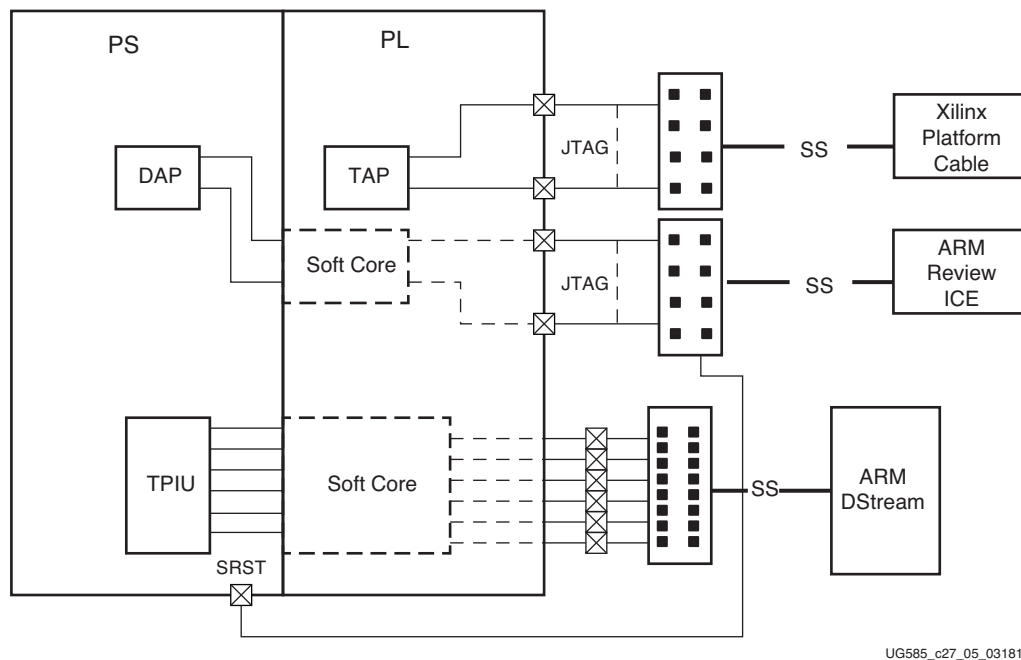

UG585_c27_05_031812

Figure 27-5: User Case II: PS and PL Debug with Trace Port Enabled

27.5 Arm DAP Controller

The debug access port (DAP) is an implementation of an Arm debug interface standard comprising a number of components supplied in a single configuration. All of the supplied components fit into the various architectural components for debug ports (DPs) which are used to access the DAP from an external debugger, and access ports (APs) to access on-chip system resources.

With the JTAG-DP, IEEE 1149.1 scan chains are used to read or write register information. A pair of scan chain registers is used to access the main control and access registers within the debug port:

- DPACC used for debug port (DP) accesses
- APACC used for access port (AP) accesses

An APACC might access a register of a debug component of the system to which the interface is connected. The scan chain model implemented by a JTAG-DP has the concepts of capturing the current value of APACC or DPACC, and of updating APACC or DPACC with a new value. An update might cause a read or write access to a DAP register that might then cause a read or write access to a debug register of a connected debug component.

Table 27-2 shows four Tap Arm DAP IR Instructions. All other IR Instructions are implemented as BYPASS.

Table 27-2: Arm DAP IR Instruction

| IR Instruction | Binary Code[3:0] | DR Width | Description |
|----------------|------------------|----------|-------------------------|
| ABORT | 1000 | 35 | JTAG-DP abort register |
| DPACC | 1010 | 35 | JTAG DP access register |
| APACC | 1011 | 35 | JTAG-AP access Register |
| ARM_IDCODE | 1110 | 32 | IDCODE for Arm DAP IP |
| BYPASS | 1111 | 1 | |

The Arm DAP is composed of one debug port (DP) and up to three access ports (APs). Among the three APs, Zynq-7000 devices only implement APB-AP as the bus master to access all debug components and AHB-AP to access system memory space directly. Table 27-3 lists all registers within the DP.

Table 27-3: DP Registers Summary

| DP Register | Access | Description |
|-------------|------------------------|--|
| CTRL/STAT | IR=DPACC/ADDRESS = 0x4 | DP Control and Status register |
| SELECT | IR=DPACC/ADDRESS = 0x8 | Its main purpose is to select the current access port and the active four-word register window in that access port |

Table 27-4 shows AHB-AP and APB-AP registers in the DAP. For each AP, there is a unique set of registers associated with each AP port. Although the DAP allows JTAG-AP, Zynq devices do not support this feature.

Table 27-4: AP Registers Summary

| AP Register | Access | Description |
|-------------|---------------------------------|-------------------------|
| CSW | IR=APACC/ADDRESS = 0x0 | Control and status word |
| TAR | IR=APACC/ADDRESS = 0x4 | Transfer address, TAR |
| DRW | IR=APACC/ADDRESS = 0xC | Data read/write |
| BD0-3 | IR=APACC/ADDRESS = 0x10 to 0x1C | Band data 0 to 3 |

27.6 Trace Port Interface Unit (TPIU)

Table 27-5 shows all registers within the TPIU.

Table 27-5: TPIU Registers Summary

| TPIU Register | Offset | Description |
|-------------------|-------------|---|
| SUPPORT_PORT_SIZE | 0x0 | 32-bit register with each bit indicating whether a single port size is allowed |
| CURRENT_PORT_SIZE | 0x4 | Indicates current trace port size with only 1 of 32-bits that could be set |
| TRIG_MODE | 0x100 | Indicates trigger mode support |
| TRG_COUNT | 0x104 | 8-bit register to enable delaying the indication of triggers to the external trace capture device |
| TRIG_MULT | 0x108 | Trigger counter multiplier |
| TEST_PATTERN | 0x200-0x208 | Configures a test pattern to generate a known bit sequence that could be capture by external capture device |
| FORMAT_SYNC | 0x300-0x308 | Control generation of stop, trigger, and flush events |

27.7 Xilinx TAP Controller

The Xilinx TAP contains four mandatory dedicated pins as specified by the protocol and typical JTAG architecture. Table 27-6 shows Xilinx TAP IR commands. Refer to [UG470, 7 Series FPGAs Configuration User Guide](#) for more details about the IR commands.

Table 27-6: JTAG Commands

| Boundary Scan Command | Binary Code[5:0] | Description |
|-----------------------|------------------|---|
| EXTEST | 000000 | Enables boundary-scan EXTEST operation |
| SAMPLE | 000001 | Enables boundary-scan SAMPLE operation |
| USER1 | 000010 | Access user-defined register 1 |
| USER2 | 000011 | Access user-defined register 2 |
| USER3 | 100010 | Access user-defined register 3 |
| USER4 | 100011 | Access user-defined register 4 |
| CFG_OUT | 000100 | Access the configuration bus for readback |
| CFG_IN | 000101 | Access the configuration bus for configuration |
| USERCODE | 001000 | Enables shifting out user code |
| IDCODE | 001001 | Enables shifting out of ID code |
| ISC_ENABLE | 010000 | Marks the beginning of ISC configuration; full shutdown is executed |

Table 27-6: JTAG Commands (Cont'd)

| Boundary Scan Command | Binary Code[5:0] | Description |
|-----------------------|------------------|--|
| ISC_PROGRAM | 010001 | Enables in-system programming |
| ISC_PROGRAM_SECURITY | 010010 | Change security status from secure to non-secure mode and vice versa |
| ISC_NOOP | 010100 | No operation |
| ISC_READ | 101011 | Used to read back BBR |
| ISC_DISABLE | 010111 | Completes ISC configuration. Startup sequence is executed |
| BYPASS | 111111 | Enables bypass |

Note: VRP and VRN pins are special pins that needs to be excluded from the boundary scan test.

System Test and Debug

28.1 Introduction

The PS and PL can be debugged together as a complete system using intrusive and non-intrusive debug techniques. In addition to software code debug, there are key hardware points in the PS and user-selected key hardware points in the PL that can capture system activity to help with the debug process.

The test and debug capability is based on the *Arm CoreSight v1.0 Architecture Specification* and consists mostly of Arm-supplied components, but also includes one Xilinx-supplied component (the fabric trace module (FTM), see [Chapter 23, Programmable Logic Test and Debug](#)). Arm CoreSight architecture defines four classes of CoreSight components: access and control, trace source, trace link, and trace sink.

Components of the access and control class provide a user interface to access the debug infrastructure through JTAG or memory-mapped locations. This class of components also coordinates the operation of separate CoreSight components with a trigger signal distribution network. Components of the trace source class capture debug information, like instruction addresses, bus transaction addresses, and generate trace packets. These trace packets are routed to components of the trace link class where trace packets can be combined or replicated. Components of the trace sink class receive trace packets and dump them into an on-chip trace buffer, or output them to chip pinouts (via the MIO) or to the PL (via the EMIO).

CoreSight components are connected together via three major types of buses/signals; programming, trigger, and trace. The programming bus is the path for the access and control class to convey programming information from the JTAG or from processors to other CoreSight components. The trigger signals are used by all classes of components to receive and send triggers from/to each other to coordinate their operation. The trace bus is the main pathway for trace packets to flow, connecting trace source, trace links, and trace sinks.

28.1.1 Features

The CoreSight components provide the following capabilities for the system-wide trace:

- Debug and trace visibility of whole systems with a single debugger connection
- Cross triggering support between SoC subsystems
- Multi-source trace in a single stream
- Higher data compression than previous solutions

- Standard programmer's models for standard tools support
- Automatic discovery of topology
- Open interfaces for third party soft cores
- Low pin count options

28.1.2 Notices

7z007s and 7z010 CLG225 Devices

The 7z007s single core and 7z010 dual core CLG225 devices support 32 MIO pins as shown in the MIO table in section 2.5.4 MIO-at-a-Glance Table. The width of the TPIU in these CLG225 devices is restricted to 1, 2 or 4-bits via the MIO pins. All 32 data signals are available on the EMIO interface. All of the CLG225 device restrictions are listed in section 1.1.3 Notices.

28.2 Functional Description

The block diagram for the CoreSight system is shown in Figure 28-1.

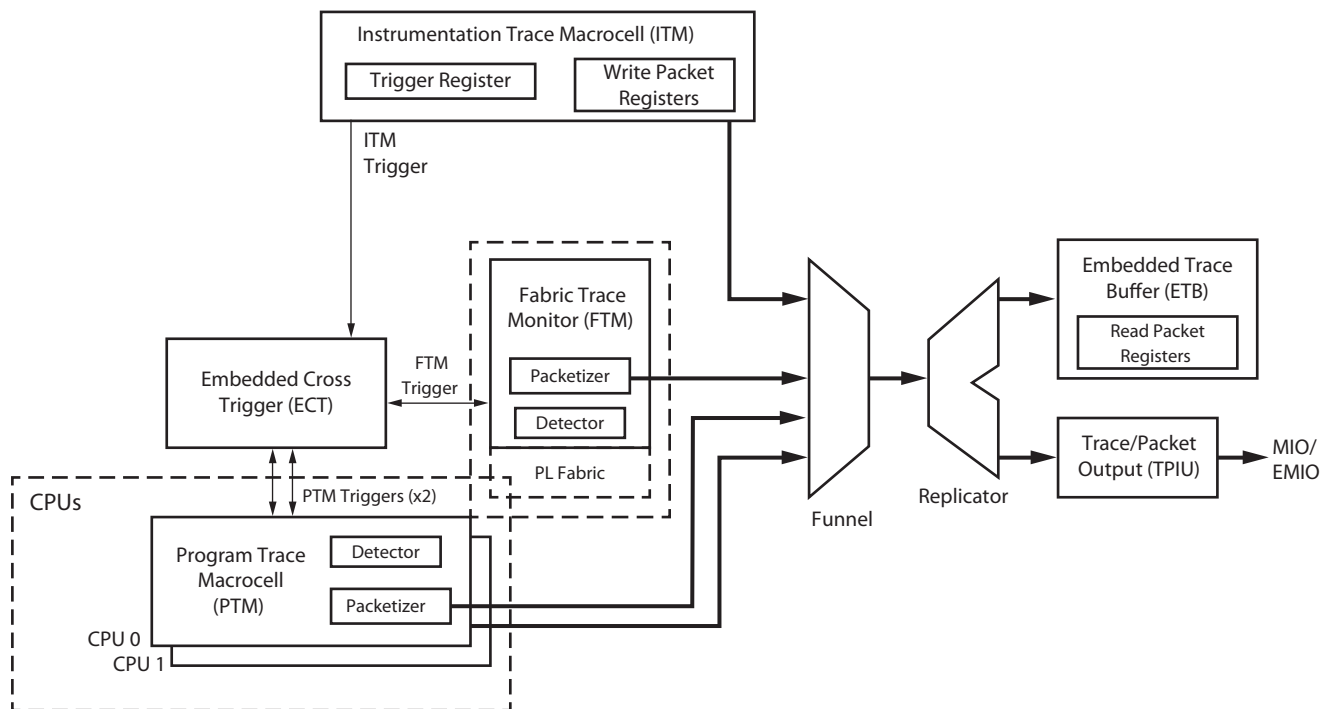

UG585_c28_01_022612

Figure 28-1: CoreSight System Block Diagram

Figure 28-1 shows the four classes of CoreSight components:

- Access and control: DAP, ECT
- Trace source: PTM, FTM, ITM
- Trace link: Funnel, Replicator
- Trace sink: ETB, TPIU

The components are connected by three types of buses/signals:

- Programming
- Trigger
- Trace

The CoreSight system interacts with:

- CPUs through PTM for debug and trace
- CPUs through ITM for trace
- PL through FTM for debug and trace
- CPUs through ETB for dumping trace
- EMIO/MIO through TPIU for dumping trace
- CPUs/JTAG through DAP for programming CoreSight components

28.2.1 Debug Access Port (DAP)

The DAP is the front-end for user access to the Zynq-7000 SoC system test and debug functionalities. It is a CoreSight component of the access and control class, and connects to other components using the programming bus. DAP provides the user, with two interfaces to access the CoreSight infrastructure:

- External: JTAG, from chip pinout
- Internal: APB slave, from the slave interconnect

A debugger can use JTAG to communicate with the CoreSight infrastructure, while software running on a CPU uses APB through memory-mapped addresses assigned to the CoreSight infrastructure. The DAP forwards access requests arriving via either interface to the requested CoreSight component.

In addition, the DAP also has another interface to access subsystems other than CoreSight, on the PS:

- Internal: AHB master, to the master interconnect

With AHB, the DAP can forward access requests from JTAG to other subsystems in the PS, subject to authentication requirements. For example, a debugger can query the value of a location in DDR or the value of a coprocessor register.

The DAP follows the access model described in *Arm Debug Interface v5 Architecture Specification* and *Arm Debug Interface v5.1 Architecture Supplement*, where JTAG indirectly accesses debug components and resources by way of registers in the DAP.

The DAP block is an Arm-supplied IP with the following configuration:

- JTAG is the only external interface on chip pinout. Serial wire interface (SW-DP) is not present.
- APB slave and AHB master are the two internal interfaces. JTAG at the DAP's internal side (JTAG-AP) is present, but only the nSRSTOUT[0] output is connected to the system reset controller.
- Power-down is not supported.

Note: When JTAG-AP nSRSTOUT[0] is used to assert system reset, DAP is removed from the JTAG chain. The same sequence for bringing DAP into the chain must be followed again.

28.2.2 Embedded Cross Trigger (ECT)

ECT is the cross-triggering mechanism. Through ECT, a CoreSight component can interact with other components by sending and receiving triggers. ECT is implemented with two components:

- CTM: Cross Trigger Matrix
- CTI: Cross Trigger Interface

One or more CTMs form an event broadcasting network with multiple channels. A CTI listens to one or more channels for an event, maps a received event into a trigger, and sends the trigger to one or more CoreSight components connected to the CTI. A CTI also combines and maps the triggers from the connected CoreSight components and broadcasts them as events on one or more channels. Both CTM and CTI are CoreSight components of the control and access class.

ECT is configured with:

- Four broadcast channels
- Four CTIs
- Power-down is not supported.

Table 28-1 lists the connections of trigger inputs and outputs of the CTIs.

Table 28-1: CTI Trigger Inputs and Outputs

| CTI Trigger Port | Signal |
|-------------------------------------|--------------------------|
| CTI (connected to ETB, TPIU) | |
| Trigger input 2 | ETB full |
| Trigger input 3 | ETB acquisition complete |
| Trigger input 4 | ITM trigger |
| Trigger output 0 | ETB flush |
| Trigger output 1 | ETB trigger |
| Trigger output 2 | TPIU flush |
| Trigger output 3 | TPIU trigger |
| CTI (connected to FTM) | |
| Trigger input 0 | FTM trigger |

Table 28-1: CTI Trigger Inputs and Outputs (Cont'd)

| CTI Trigger Port | Signal |
|--------------------------------|----------------------|
| Trigger input 1 | FTM trigger |
| Trigger input 2 | FTM trigger |
| Trigger input 3 | FTM trigger |
| Trigger output 0 | FTM trigger |
| Trigger output 1 | FTM trigger |
| Trigger output 2 | FTM trigger |
| Trigger output 3 | FTM trigger |
| CTI (connected to CPU0) | |
| Trigger input 0 | CPU0 DBGACK |
| Trigger input 1 | CPU0 PMU IRQ |
| Trigger input 2 | PTM0 EXT |
| Trigger input 3 | PTM0 EXT |
| Trigger input 4 | CPU0 COMMTX |
| Trigger input 5 | CPU0 COMMRX |
| Trigger input 6 | PTM0 TRIGGER |
| Trigger output 0 | CPU0 debug request |
| Trigger output 1 | PTM0 EXT |
| Trigger output 2 | PTM0 EXT |
| Trigger output 3 | PTM0 EXT |
| Trigger output 4 | PTM0 EXT |
| Trigger output 7 | CPU0 restart request |
| CTI (connected to CPU1) | |
| Trigger input 0 | CPU1 DBGACK |
| Trigger input 1 | CPU1 PMU IRQ |
| Trigger input 2 | PTM1 EXT |
| Trigger input 3 | PTM1 EXT |
| Trigger input 4 | CPU1 COMMTX |
| Trigger input 5 | CPU1 COMMRX |
| Trigger input 6 | PTM1 TRIGGER |
| Trigger output 0 | CPU1 debug request |
| Trigger output 1 | PTM1 EXT |
| Trigger output 2 | PTM1 EXT |
| Trigger output 3 | PTM1 EXT |
| Trigger output 4 | PTM1 EXT |
| Trigger output 7 | CPU1 restart request |

Note: For details on the two CTIs connected to CPU0 and CPU1, refer to the *CoreSight PTM-A9 Technical Reference Manual, r1p0, DDI0401C*, section 1.3.6.

28.2.3 Program Trace Macrocell (PTM)

The PTM is the block for tracing processor execution flow. It is based on the Arm program flow trace (PFT) architecture, and is a CoreSight component of the trace source class. The PTM generates information that trace tools use to reconstruct the execution of a program, by tracing only certain points in program execution called waypoints. This reduces the amount of trace data. Timestamps are supported for correlating multiple trace streams and coarse grain code profiling.

The PTM provides some general resources, such as address/ID comparators, counter, sequencers, for setting up user-defined event triggering conditions. This enhances the base functions of tracing program execution.

The PTM block in Zynq-7000 SoC devices is the standard Arm-supplied IP, with the no custom configuration.

28.2.4 Instrumentation Trace Macrocell (ITM)

The ITM is the block for software to generate a trace. It is a CoreSight component of the trace source class. Triggering and coarse-grained time stamping are also supported. The main uses include:

- printf style debugging
- Trace OS and application events
- Emit diagnostic system information

The ITM block in Zynq-7000 SoC devices is the standard Arm-supplied IP, with the no custom configuration.

28.2.5 Funnel

The funnel is the block for merging trace data from multiple sources into a single stream. It is a CoreSight component of the trace link class. Users select the sources to be merged and assign priorities to them.

The funnel in Zynq-7000 SoC devices is the standard Arm-supplied IP, with the no custom configuration.

[Table 28-2](#) lists the connections of the input ports of the Funnel.

Table 28-2: Funnel Input Port List

| Port | Trace Source |
|------|--------------|
| 0 | PTM0 |
| 1 | PTM1 |
| 2 | FTM |

Table 28-2: Funnel Input Port List (Cont'd)

| Port | Trace Source |
|------|--------------|
| 3 | ITM |
| 4-7 | unused |

28.2.6 Embedded Trace Buffer (ETB)

The ETB is the on-chip storage of trace data. It is a CoreSight component of the trace sink class. The ETB provides real-time full-speed storing capability, but is limited in size. Triggering is supported for events such as buffer full and acquisition complete.

The ETB block in Zynq-7000 SoC devices is an Arm-supplied IP, with the following configuration:

- RAM size: 4 KB

28.2.7 Trace Packet Output (TPIU)

The TPIU is the block for outputting trace data to the PL or to chip pinout. It is a CoreSight component of the trace sink class. The TPIU provides unlimited trace data output, but is limited in bandwidth. Triggering and flushing are both supported.

The TPIU block is an Arm-supplied IP, with the following configuration:

- Max data width: 32

Table 28-3 shows the two operating modes of TPIU.

Table 28-3: Operating Modes of TPIU

| | slcr.DBG_CLK_CTRL[6], MIO_PIN_xx (Details in Table 28-4) | |
|--|---|--|
| | 1 | 0 |
| Active interface | EMIO | MIO |
| Clock source to operate the TPIU | EMIOTRACECLK | PS clock controller |
| Output clock present? | No | Yes |
| Clock edge(s) to sample trace data and control | Rising | Rising and falling |
| Supported data widths | 1, 2, 4, 8, 16, 32 | 1, 2, 4, 8, 16 |
| Application Note | Since PL supplies the clock to TPIU, PL can use the same clock to sample. | External device should delay the trace clock output by approximately half clock period, and use the delayed clock to sample. |

Figure 28-2 shows the waveforms of TPIU I/O signals in the two modes. In EMIO mode, the PL supplies the trace clock signal to TPIU; PL can use the same clock to sample the trace data and control signals from PS. In MIO mode, all signals, including data, control, and clock, are aligned at the selected MIO pins; therefore, the external device should delay the trace clock output by approximately half the clock period to successfully sample the trace data and control signals. Before

changing the active interface to EMIO, ensure that EMIOTRACECLK is running. Changing the clock input source to a non-running clock results in an APB access hang.

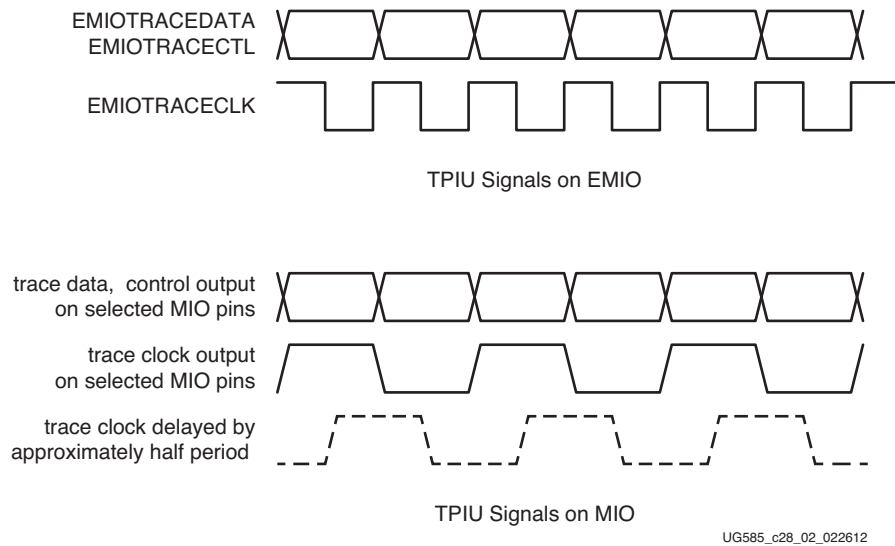

Figure 28-2: TPIU Operating Mode Waveforms

28.3 I/O Signals

Table 28-4 identifies the TPIU port signals. The TPIU port data can be routed to either an MIO or EMIO interface, but not both. EMIO supports 32-bit data at a single data rate clock that is sourced from the PL as an EMIO input.

MIO supports 16-bit data at a double data rate clock sourced by the clock generator and driven out on MIO. Pin restrictions based on device version are explained in section 28.1.2 Notices.

Table 28-4 identifies the system test and debug I/O signals. The MIO pins and any restrictions based on device version are shown in the MIO table in section 2.5.4 MIO-at-a-Glance Table.

Table 28-4: TPIU Signals List

| TPIU Signal | Default Input Value | MIO Pins | | | EMIO Signals | |
|------------------|---------------------|----------|-----|-----------|--------------|-----|
| | | Number | I/O | Pin Name | Signal Name | I/O |
| EMIO trace clock | 0 | ~ | ~ | ~ | EMIOTRACECLK | I |
| MIO Trace Clock | ~ | 12 or 24 | O | TRACE_CLK | ~ | ~ |
| Trace control | ~ | 13 or 25 | O | TRACE_CTL | EMIOTRACECTL | O |

Table 28-4: TPIU Signals List (Cont'd)

| TPIU Signal | Default Input Value | MIO Pins | | | EMIO Signals | | |
|-------------|---------------------|----------|----------------------------------|----------|------------------|---------------------|---|
| | | Number | I/O | Pin Name | Signal Name | I/O | |
| Trace data | ~ | 1-bit | 14 or 26 | O | TRACE_DATA[15:0] | EMIOTRACEDATA[31:0] | O |
| | | 2-bit | 15, 14 or 27, 26 | | | | |
| | | 4-bit | 11, 10, 15, 14 or 23, 22, 27, 26 | | | | |
| | | 8-bit | 11, 10, 15, 14 or 23, 22, 27, 26 | | | | |
| | | 16-bit | 9-2,19-16,11,10,15,14 | | | | |

28.4 Register Overview

28.4.1 Memory Map

Per the CoreSight specification, each CoreSight component has 4 kB address space. Table 28-5 lists the base address of each CoreSight component.

Table 28-5: Memory Map

| Component | Base Address |
|-------------------------------|--------------|
| DAP ROM | 0xF880_0000 |
| ETB | 0xF880_1000 |
| CTI (connected to ETB, TPIU) | 0xF880_2000 |
| TPIU | 0xF880_3000 |
| Funnel | 0xF880_4000 |
| ITM | 0xF880_5000 |
| CTI (connected to FTM) | 0xF880_9000 |
| FTM | 0xF880_B000 |
| Cortex-A9 ROM | 0xF888_0000 |
| CPU0 debug logic | 0xF889_0000 |
| CPU0 PMU | 0xF889_1000 |
| CPU1 debug logic | 0xF889_2000 |
| CPU1 PMU | 0xF889_3000 |
| CTI (connected to CPU0, PTM0) | 0xF889_8000 |
| CTI (connected to CPU1, PTM1) | 0xF889_9000 |
| PTM0 (for CPU0) | 0xF889_C000 |
| PTM1 (for CPU1) | 0xF889_D000 |

Note: CPU0 debug logic and CPU1 debug logic can also be accessed through CP14 coprocessor instructions. See the *Cortex-A9 Technical Reference Manual* for details.

28.4.2 Functionality

Table 28-6 summarizes the registers in each CoreSight component.

Table 28-6: CoreSight Component Register Summary

| Function | Name | Overview |
|----------------------------------|---|--|
| DAP ROM | | |
| Pointers | Entry0-9 | Pointers to other CoreSight components |
| CoreSight management | Peripheral ID0-7 Component ID0-3 | These registers provide identification information |
| ETB | | |
| Control | CTL | Enable/disable capture |
| Status | STS | Status on pipeline, acquisition, trigger, full/empty |
| RAM depth | RDP | Depth of RAM in words |
| RAM read | RRD, RRP | Read pointer and data |
| RAM write | RWD, RWP | Write pointer and data |
| Trigger counter | TRG | Sets the number of words to be stored after a trigger event |
| Formatter and flush | FFCR, FFSR | Stop events, trigger mark, flush start, formatting control |
| CoreSight management | Peripheral ID Component ID Device ID, type Claim, lock, authentication Integration test | These registers provide: <ul style="list-style-type: none"> • Identification information • Authentication and access control • Integration test |
| CTI | | |
| Control | CONTROL | Enable/disable CTI |
| Acknowledge | INTACK | Provide for SW to acknowledge TRIGOUT when no hardware acknowledge is supplied |
| Channel event generation | APPSET, APPCLR, APPPULSE | Raise/clear/pulse channel events, used with GATE register to create local events |
| Channel event gating | GATE | Prevent the channel events from propagating to other CTI's in the system |
| Forwarding control | INEN, OUTEN | Enable the forwarding of events between the trigger interface and the channel interface |
| Trigger/Channel interface status | TRIGINSTATUS, TRIGOUTSTATUS, CHINSTATUS, CHOUTSTATUS | Provide the current status of the trigger and channel interfaces |

Table 28-6: CoreSight Component Register Summary (Cont'd)

| Function | Name | Overview |
|----------------------------------|---|--|
| CoreSight management | Peripheral ID Component ID Device ID, type Claim, lock, authentication Integration test | These registers provide: <ul style="list-style-type: none"> • Identification information • Authentication and access control • Integration test |
| TPIU | | |
| Supported feature | | Show maximum and current values of supported port size, test patterns, etc. |
| Trigger | | Set Trigger counter, multiplier |
| Testing | | Set test pattern, modes and repeat count |
| Format and finish | | Control and status of formatter and flush |
| CoreSight management | Peripheral ID Component ID Device ID, type Claim, lock, authentication Integration test | These registers provide: <ul style="list-style-type: none"> • Identification information • Authentication and access control • Integration test |
| Funnel | | |
| Control | Control, Priority | Enable slave ports, set hold time, and priority |
| CoreSight management | Peripheral ID Component ID Device ID, type Claim, lock, authentication Integration test | These registers provide: <ul style="list-style-type: none"> • Identification information • Authentication and access control • Integration test |
| ITM | | |
| Control | CR, SCR | Enable ITM, configure features like timestamp, sync packets, sync count, etc. |
| Stimulus | SPR | Cause the write data to be inserted into the FIFO for packets |
| Trace | TER, TTR | Enable trace and trigger |
| CoreSight management | Peripheral ID Component ID Device ID, type Claim, lock, authentication Integration test | These registers provide: <ul style="list-style-type: none"> • Identification information • Authentication and access control • Integration test |
| FTM | | |
| Cortex-A9 Integration ROM | | |
| Pointers | Entry | Pointers to other CoreSight components for A9 |
| CoreSight management | Peripheral ID Component ID | These registers provide identification information |
| CPU debug | | |

Table 28-6: CoreSight Component Register Summary (Cont'd)

| Function | Name | Overview |
|------------------------|---|--|
| Control | DBGDSCCR | Controls cache behavior while the CPU is in debug state |
| Breakpoints | BVR BCR | Set breakpoint values, and control breakpoints. A breakpoint can be set on an Instruction Virtual Address (IVA) or/and a Context ID |
| Watchpoints | WVR WCR | Set watchpoint values, and control watchpoints. A watchpoint can be set on a Data Virtual Address (DVA) or with a Context ID |
| CoreSight management | Peripheral ID Component ID Device ID, type Claim, lock, authentication Integration test | These registers provide: <ul style="list-style-type: none"> • Identification information • Authentication and access control • Integration test |
| CPU PMU | | |
| Control | PMCR | Performance monitor control |
| Status | PMOVSr | Overflow flag status |
| Counter | PMCNTENSET PMCNTENCLR PMSELR PMCCNTR | Counter enable set/clear, software increment, cycle count |
| Event counters | PMXEVTYPER PMXVCNTR | Counters to gather statistics on the operation of the processor and memory system |
| User enable | PMUSERENR | User enable |
| Interrupt Enable | PMINTENSET PMINTENCLR | Interrupt enable set/clear |
| PTM | | |
| Configuration | ETMCR, ETMCCR, ETMTRIGGER, ETMSR, ETMSCR | Main control registers, configuration, set trigger events, and status |
| Trace Enable control | ETMSSSCR, ETMTTEVR, ETMTECR1 | Trace enable start/stop, Trace enable event, Trace enable control |
| Address comparators | ETMACVR, ETMACTR | Address comparator values, types |
| Counters | ETMCNTRLDVR, ETMCNTENR, ETMCNTVR | Counter reload values, enable events, reload events, current values |
| Sequencers | ETMSQMNEVR, ETMSQR | Sequencer state transition events, sequencer current state |
| External output event | ETMEXTOUTEVER | Set events that control the corresponding external output |
| Context ID comparators | ETMCIDCVR1, ETMCIDCMR | Context ID comparator value, mask Sync frequency, ID |
| General control | ETMSYNCFR, ETMIDR | Sync frequency, ID |

Table 28-6: CoreSight Component Register Summary (Cont'd)

| Function | Name | Overview |
|----------------------|---|--|
| Misc. | ETMCCER, ETMEXTINSEL, ETMTSEVR, ETMAUXCR, ETMTRACEIDR, ETMOSLSR | Configuration code, external input selection, timestamp, auxiliary control, CoreSight trace ID, OS lock, power-down |
| CoreSight management | Peripheral ID Component ID Device ID, type Claim, lock, authentication Integration test | These registers provide: <ul style="list-style-type: none"> • Identification information • Authentication and access control • Integration test |

28.5 Programming Model

28.5.1 Authentication Requirements

Arm CoreSight infrastructure uses four signals to control authentication:

- DBGEN Invasive debug enable
- NIDEN Non-invasive debug enable
- SPIDEN Secure invasive debug enable
- SPNIDEN Secure non-invasive debug enable

Table 28-7 lists the Zynq-7000 SoC device authentication requirements for the CoreSight components.

Table 28-7: CoreSight Authentication Requirements by Component

| Requirement | DBGEN | NIDEN | SPIDEN | SPNIDEN |
|--|-------|-------|--------|---------|
| DAP AHB master | | | | |
| Non-secure access | 1 | x | 0 | x |
| Secure access | 1 | x | 1 | x |
| CTI (connected to ETB, TPIU) CTI (connected to FTM) | | | | |
| Enable all trigger inputs | x | x | x | x |
| Enable all trigger outputs | x | x | x | x |
| CTI (connected to CPU0) CTI (connected to CPU1) | | | | |
| Enable trigger input 0 | x | 1 | x | x |
| Enable trigger input 1 | x | 1 | x | x |
| Enable trigger input 2 | x | 1 | x | x |
| Enable trigger input 3 | x | 1 | x | x |
| Enable trigger input 4 | x | 1 | x | x |

Table 28-7: CoreSight Authentication Requirements by Component (Cont'd)

| Requirement | DBGEN | NIDEN | SPIDEN | SPNIDEN |
|----------------------------------|---|-------|--------|---------|
| Enable trigger input 5 | x | 1 | x | x |
| Enable trigger input 6 | x | 1 | x | x |
| Trigger output 0 | 1 | x | x | x |
| Trigger output 1 | x | x | x | x |
| Trigger output 2 | x | x | x | x |
| Trigger output 3 | x | x | x | x |
| Trigger output 4 | x | x | x | x |
| Trigger output 6 | 1 | x | x | x |
| Trigger output 7 | x | x | x | x |
| Funnel | | | | |
| TPIU | | | | |
| ETB | | | | |
| (no authentication is required) | x | x | x | x |
| ITM | | | | |
| Disable stimulus registers 0-15 | 0 | 0 | 0 | 0 |
| Disable stimulus registers 16-31 | x | x | 0 | 0 |
| CPU debug | | | | |
| CPU PMU | | | | |
| Non-secure invasive debug | 1 | x | x | x |
| Non-secure non-invasive debug | 1 | x | x | x |
| | 0 | 1 | x | x |
| Secure invasive debug | 1 | x | 1 | x |
| Secure non-invasive debug | 1 | x | 1 | x |
| | 1 | x | x | 1 |
| | x | 1 | 1 | x |
| | x | 1 | x | 1 |
| PTM | | | | |
| Prohibited regions of trace | Use the following to determine: if (~NIDEN & ~DBGEN) Prohibited = 1 else if (security level == non-secure) Prohibited = 0 else if ((privilege level == user) & (SUNIDEN)) Prohibited = 0 else if (SPIDEN SPNIDEN) Prohibited = 0 else Prohibited = 1 | | | |

On-Chip Memory (OCM)

29.1 Introduction

The on-chip memory (OCM) module contains 256 KB of RAM and 128 KB of ROM (BootROM). It supports two 64-bit AXI slave interface ports, one dedicated for CPU/ACP access via the APU snoop control unit (SCU), and the other shared by all other bus masters within the processing system (PS) and programmable logic (PL). The BootROM memory is used exclusively by the boot process and is not visible to the user.

OCM supports high AXI read and write throughput for RAM access by implementing the RAM as a double-wide memory (128 bits). To take advantage of the high RAM access throughput, the user application must use even AXI burst sizes and 128-bit aligned addresses.

The TrustZone feature is supported at 4-KB memory granularity. The entire 256 KB of RAM can be divided into sixty four 4-KB blocks, and assigned security attributes independently. See *Programming Arm TrustZone Architecture on the Xilinx Zynq-7000 SoC* (UG1019).

As shown in [Figure 29-1](#), there are 10 AXI channels associated with the OCM, five for the CPU/ACP (SCU) port and five for the other PS/PL masters (OCM switch port). Arbitration between the read and write channels of the SCU and OCM switch ports is performed within the OCM module. Parity generation and checking is performed on RAM accesses only. Other main interfaces are an interrupt signal (IRQ ID #35) as well as a register access APB port.

29.1.1 Block Diagram

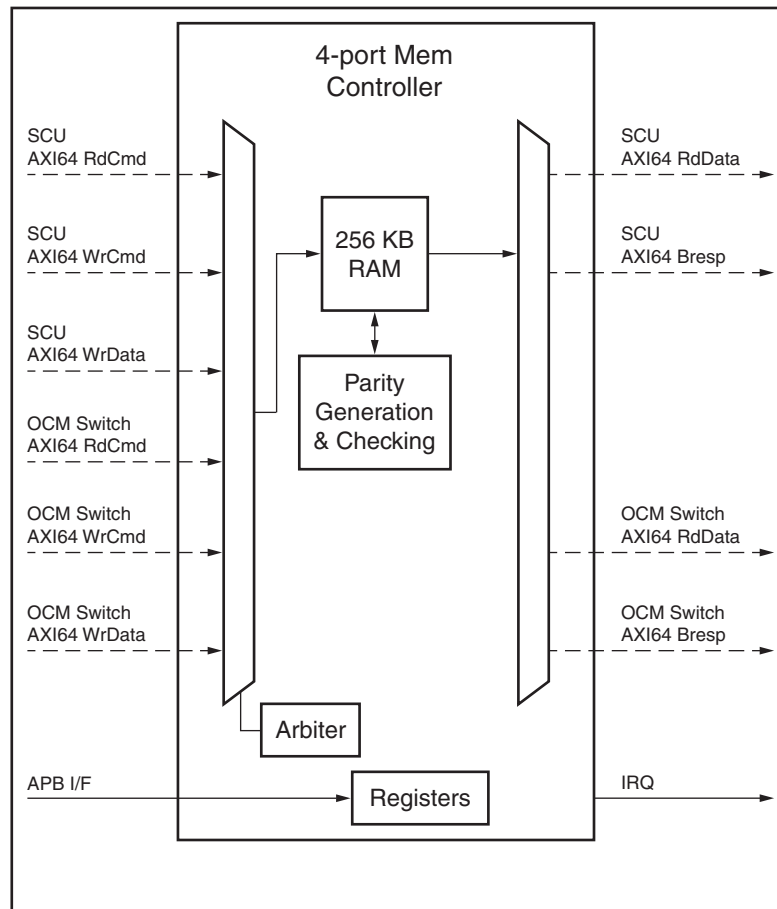

UG585_c29_01_042512

Figure 29-1: OCM Block Diagram

29.1.2 Features

Key features of the OCM include:

- On-chip 256 KB RAM
- On-chip 128 KB BootROM (not user visible)
- Two AXI 3.0, 64-bit slave interfaces
- Low latency path for CPU/ACP reads to OCM (CPU at 667 MHz – minimum 23 cycles)
- Round-robin pre-arbitration between read and write AXI channels on OCM-interconnect port (non-CPU port)
- Fixed priority arbitration between the CPU/ACP (via SCU) and OCM-interconnect AXI ports
- Supports full AXI 64-bit bandwidth of simultaneous read and write commands (with optimal alignment restrictions) on the OCM interconnect port
- Random access supported to RAM from AXI masters

- TrustZone support for on-chip RAM with 4 KB page granularity
- Flexible address mapping capability
- RAM byte-wise parity generation, checking, and interrupt support
- Support for the following non-AXI features on the CPU (SCU) port:
 - Zero line fill
 - Pre-fetch hint
 - Early BRESP
 - Speculative line pre-fetch

29.1.3 System Viewpoint

A system viewpoint of the OCM is illustrated in [Figure 29-2](#).

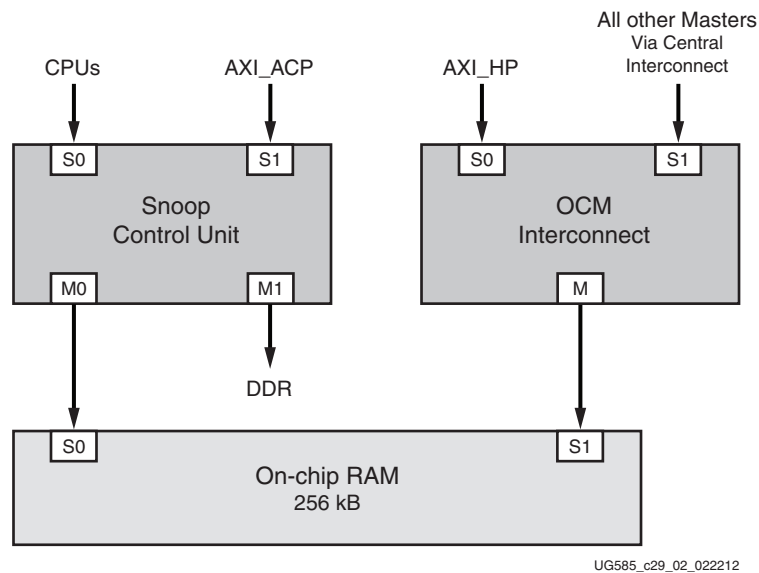

Figure 29-2: OCM System Viewpoint

29.2 Functional Description

29.2.1 Overview

The OCM module is mainly composed of a RAM memory block. The OCM module also contains arbitration, framing, parity, and interrupt logic in addition to the RAM array.

29.2.2 Optimal Transfer Alignment

The RAM is implemented as a single-ported, double-width (128-bit) module that can emulate a dual-ported memory under specific conditions. This emulation of dual-ported operation occurs automatically when 128-bit aligned, even burst multiples of AXI commands are used to access the 64-bit wide OCM AXI interfaces. Optimized bursts are theoretically able to achieve 100% throughput of the RAM. If bursts are not aligned to 128 bits or burst lengths are odd multiples of 64-bits, the control logic automatically realigns transfers inside the module — start and end addresses can be presented to the RAM as 64-bit operations instead of more optimal 128-bit operations.

Configuring OCM memory as *device memory* in the MMU or using narrow, non-modifiable accesses through the ACP port is not recommended. In this mode, pipelined 32-bit accesses are generated on the SCU port. This type of traffic pattern does not take advantage the double-width memory and effectively reduces OCM efficiency to 25%.

29.2.3 Clocking

The OCM module is clocked by the CPU_6x4x clock. However, the RAM array itself is an exception, and is clocked by CPU_2x, though its 128-bit width is double that of any of the incoming 64-bit wide AXI channels. The OCM switch feeding the OCM module is clocked by CPU_2x, and the SCU is clocked by CPU_6x4x.

29.2.4 Arbitration Scheme

Apart from the CPUs and ACP, all other AXI bus masters are assumed to not have a strong latency requirement. Therefore, the OCM uses a fixed arbitration scheme (on a data beat basis) between the two AXI slave interfaces. The default order of decreasing priorities is:

1. SCU-Rd
2. SCU-Wr
3. OCM-Switch

Using the `ocm.OCM_CONTROL.ScuWrPriorityLo` register setting (see [Appendix B, Register Details](#)), the decreasing priority arbitration can be modified to:

1. SCU-Rd
2. OCM-Switch
3. SCU-Wr

Arbitration is implemented as shown in Figure 29-3.

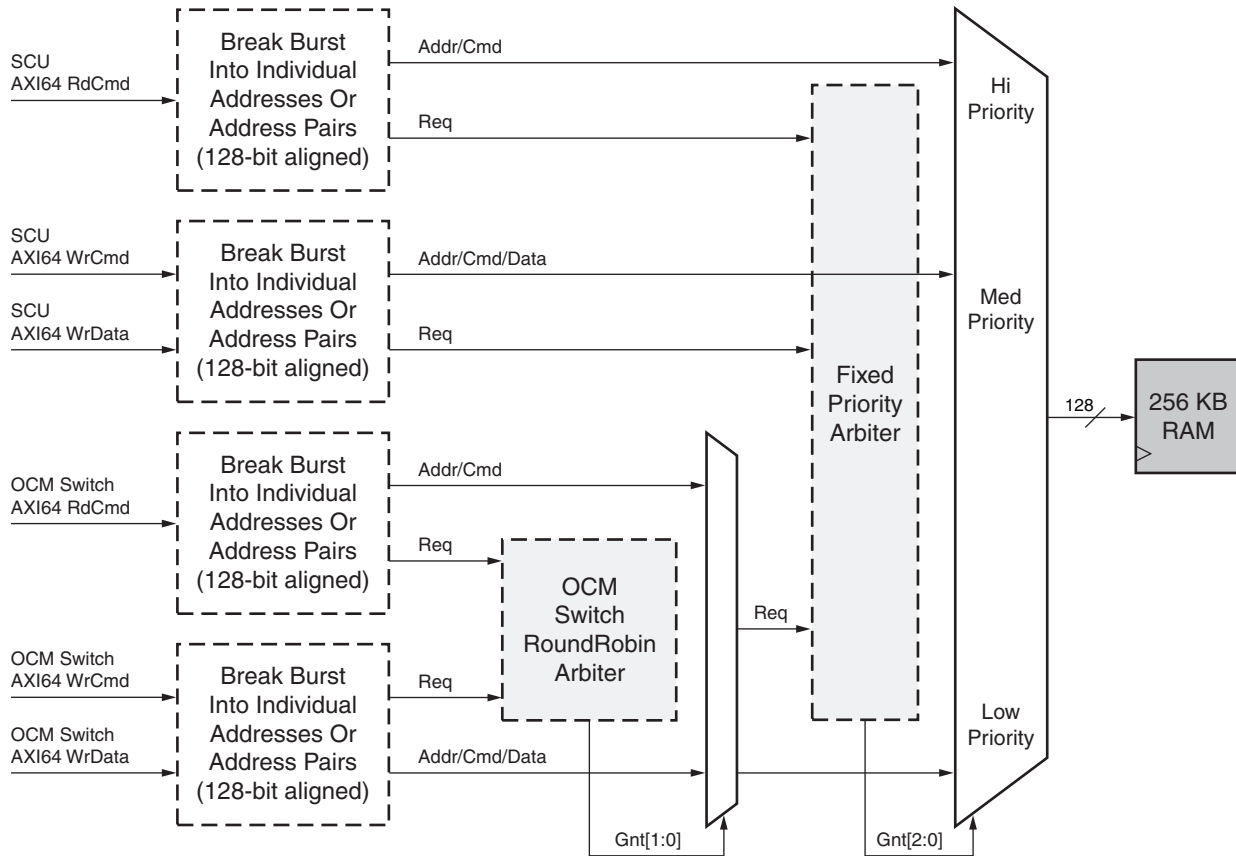

UG585_c29_03_042512

Figure 29-3: Default (ScuWrPriorityLo=0) OCM Arbitration

There is an additional round-robin pre-arbitration process that selects between a read or write transaction on a per data-beat basis for the OCM-switch port traffic.

Note: Arbitration is performed on a transfer (data beat or clock cycle) basis, not on an AXI command basis. The in-coming AXI read and write commands are split into individual addresses (or 128-bit address pairs for aligned bursts) before arbitration.

Note: Each individual write address beat will not request access to the memory array until the write data associated with it is available inside the OCM module — this prevents the scenario of a write request being stalled due to write data not being available.

Starvation Scenarios

System constraints on the OCM are:

- The RAM array and OCM Switch port are clocked with CPU_2x which runs at one third or one half the CPU clock.
- The SCU (CPU/ACP) port is clocked at full the CPU clock rate.
- Each of the four incoming AXI data channels are 64-bits wide.

- The RAM array is 128-bits wide.
- The OCM switch port has separate read and write channels that can be simultaneously active.
- The SCU (CPU/ACP) port has separate read and write channels that can be simultaneously active.
- The SCU (CPU/ACP) port channels have a fixed arbitration priority higher than the OCM switch port by default.

As a result of these constraints, saturation of the RAM can occur by the SCU CPUs or ACP interfaces, starving the OCM switch and the masters it serves. However, if the CPU(s) are running with caches on, the rate at which they produce new commands to this module is sufficiently low to allow the OCM switch port to share the RAM. The arbitration priority of the OCM switch can also be raised above the priority of the SCU write channels.

Configuring OCM memory as *Device Memory* in the MMU or using narrow, non-modifiable accesses through the ACP can also contribute to OCM switch port starvation; see section [29.2.2 Optimal Transfer Alignment](#).

In general, the guidelines of ACP usage detailed under the ACP chapter should be followed, as this port effectively produces commands on the SCU port to the OCM, which might cause starvation to the OCM switch.

29.2.5 Address Mapping

The address range assigned to the OCM can be modified to exist in the first or last 256 KB of the address map, to flexibly handle the Arm low or high exception vector modes. In addition, the CPU and ACP AXI interfaces can have their lowest 1 MB address range accesses diverted to DDR, using the SCU address filtering feature. This section describes these features through a series of example address configurations.

Mapping Summary

(See [Appendix B, Register Details](#) for detailed register information.)

When addressing the OCM the following details should be considered:

- The 256 KB RAM array can be mapped to either a low address range (0x0000_0000 to 0x0003_FFFF) or a high address range (0xFFFFC_0000 to 0xFFFF_FFFF) in a granularity of four independent 64 KB sections via the 4-bit slcr.OCM_CFG[RAM_HI].
- The SCU address filtering (mpcore.SCU_CONTROL_REGISTER[Address_filtering_enable]) field is set by hardware on any form of reset and should not be disabled by the user. Address filtering on non-OCM addresses is necessary to correctly route transactions between the two downstream SCU ports. The address filtering range has a 1 MB granularity.
- The SCU address filtering feature is able to redirect accesses from its CPU and ACP masters targeting the range (0x0000_0000 to 0x000F_FFFF) which includes the OCM's low address range, to the PS DDR DRAM, independent of the RAM address settings.
- For each 64 KB section mapped to the high OCM address range via slcr.OCM_CFG[RAM_HI] which is not also part of the SCU address filtering range will be aliased for CPU and ACP masters at a range of 0x000C_0000-0x000F_FFFF.

- All other masters that do not pass through the SCU are always unable to access the lower 512 KB of DDR in the OCM's low address range (0x0000_0000 to 0x0007_FFFF).
- Accesses to addresses which the RAM array is not currently mapped to are given an error response.

Initial View

Upon entering user mode, the BootROM is no longer accessible, and the RAM space is split. Note that one 64 KB range resides at the high OCM address, and the other 192 KB resides at the lower address range. Table 29-1 and Table 29-2 identify the initial OCM/DDR address map and register settings, respectively.

Attempted accesses to reserved areas return all zeroes along with a SLVERR bus response.

Table 29-1: Initial OCM/DDR Address Map

| Address Range (Hex) | Size | CPUs/ACP | Other Masters |
|-----------------------|----------|--------------|---------------|
| 0000_0000 - 0000_FFFF | 64 KB | OCM | OCM |
| 0001_0000 - 0001_FFFF | 64 KB | OCM | OCM |
| 0002_0000 - 0002_FFFF | 64 KB | OCM | OCM |
| 0003_0000 - 0003_FFFF | 64 KB | Reserved | Reserved |
| 0004_0000 - 0007_FFFF | 256 KB | Reserved | Reserved |
| 0008_0000 - 000B_FFFF | 256 KB | Reserved | DDR |
| 000C_0000 - 000C_FFFF | 64 KB | Reserved | DDR |
| 000D_0000 - 000D_FFFF | 64 KB | Reserved | DDR |
| 000E_0000 - 000E_FFFF | 64 KB | Reserved | DDR |
| 000F_0000 - 000F_FFFF | 64 KB | OCM3 (alias) | DDR |
| 0010_0000 - 3FFF_FFFF | 1,023 MB | DDR | DDR |
| FFFC_0000 - FFFC_FFFF | 64 KB | Reserved | Reserved |
| FFFD_0000 - FFFD_FFFF | 64 KB | Reserved | Reserved |
| FFFE_0000 - FFFE_FFFF | 64 KB | Reserved | Reserved |
| FFFF_0000 - FFFF_FFFF | 64 KB | OCM3 | OCM3 |

Table 29-2: Initial Register Settings

| Register | Value |
|---|-------------|
| slcr.OCM_CFG[RAM_HI] | 1000 |
| mpcore.SCU_CONTROL_REGISTER[Address_filtering_enable] | 1 |
| mpcore.Filtering_Start_Address_Register | 0x0010_0000 |
| mpcore.Filtering_End_Address_Register | 0xFFE0_0000 |

OCM Relocation

For a contiguous RAM address range, RAM located at address 0x0000_0000 to 0x0002_FFFF can be relocated to base address 0xFFFC_0000 by programming the SLCR registers.

Each bit of slcr.OCM_CFG[RAM_HI] corresponds to a 64 KB range, with the MSB corresponding to the highest address offset range. For more register programming details, refer to the SLCR information in the system level control registers section of [Appendix B, Register Details](#).

[Table 29-3](#) and [Table 29-4](#) identify an example OCM relocation address map and OCM relocation register settings, respectively.

Table 29-3: Example OCM Relocation Address Map

| Address Range (Hex) | Size | CPUs/ACP | Other Masters |
|-----------------------|----------|--------------|---------------|
| 0000_0000 - 0000_FFFF | 64 KB | Reserved | Reserved |
| 0001_0000 - 0001_FFFF | 64 KB | Reserved | Reserved |
| 0002_0000 - 0002_FFFF | 64 KB | Reserved | Reserved |
| 0003_0000 - 0003_FFFF | 64 KB | Reserved | Reserved |
| 0004_0000 - 0007_FFFF | 256 KB | Reserved | Reserved |
| 000C_0000 - 000C_FFFF | 64 KB | OCM0 (alias) | DDR |
| 000D_0000 - 000D_FFFF | 64 KB | OCM1 (alias) | DDR |
| 000E_0000 - 000E_FFFF | 64 KB | OCM2 (alias) | DDR |
| 000F_0000 - 000F_FFFF | 64 KB | OCM3 (alias) | DDR |
| 0010_0000 - 3FFF_FFFF | 1,023 MB | DDR | DDR |
| | | | |
| FFFC_0000 - FFFC_FFFF | 64 KB | OCM0 | OCM0 |
| FFFD_0000 - FFFD_FFFF | 64 KB | OCM1 | OCM1 |
| FFFE_0000 - FFFE_FFFF | 64 KB | OCM2 | OCM2 |
| FFFF_0000 - FFFF_FFFF | 64 KB | OCM3 | OCM3 |

Table 29-4: Example OCM Relocation Register Settings

| Register | Value |
|---|-------------|
| slcr.OCM_CFG[RAM_HI] | 1111 |
| mpcore.SCU_CONTROL_REGISTER[Address_filtering_enable] | 1 |
| mpcore.Filtering_Start_Address_Register | 0x0010_0000 |
| mpcore.Filtering_End_Address_Register | 0xFFE0_0000 |

SCU Address Filtering

The view of the OCM as seen by the CPUs and ACP via the SCU port relative to other masters via the OCM switch is potentially different. The SCU uses its own dedicated address filtering mechanism to address slaves other than the OCM while the other bus masters in the system are routed via a fixed address decode scheme built into the system interconnects.

These other bus masters always see the OCM with accesses (from address 0x0000_0000 to 0x0007_FFFF and address 0xFFFC_0000 to 0xFFFF_FFFF) going to OCM space. Depending on how the SLCR OCM registers are configured, these accesses either terminate at the RAM array or to a default reserved address, resulting in an AXI SLVERR error. These other masters potentially see gaps in the RAM address maps.

The CPU/ACP view, however, can be different using the SCU address filtering. For example, if the CPU wants DDR DRAM to be located at address 0x0000_0000, it can configure the address filtering and SLCR OCM registers so that the address map shown in Table 29-5 is seen. In Table 29-5, note that the CPU/ACP masters are able to address the entire DDR address range, while all other masters cannot address the lower 512 KB of DDR. Table 29-6 identifies example of OCM relocation register settings.

Table 29-5: Example SCU Address Filtering Address Map

| Address Range (Hex) | Size | CPUs/ACP | Other Masters |
|-----------------------|----------|----------|---------------|
| 0000_0000 - 0007_FFFF | 512 KB | DDR | Reserved |
| 0008_0000 - 000F_FFFF | 512 KB | DDR | DDR |
| 0010_0000 - 3FFF_FFFF | 1,023 MB | DDR | DDR |
| FFFC_0000 - FFFC_FFFF | 64 KB | OCM0 | OCM0 |
| FFFD_0000 - FFFD_FFFF | 64 KB | OCM1 | OCM1 |
| FFFE_0000 - FFFE_FFFF | 64 KB | OCM2 | OCM2 |
| FFFF_0000 - FFFF_FFFF | 64 KB | OCM3 | OCM3 |

Table 29-6: Example OCM Relocation Register Settings

| Register | Value |
|---|-------------|
| slcr.OCM_CFG[RAM_HI] | 1111 |
| mpcore.SCU_CONTROL_REGISTER[Address_filtering_enable] | 1 |
| mpcore.Filtering_Start_Address_Register | 0x0000_0000 |
| mpcore.Filtering_End_Address_Register | 0xFFE0_0000 |

29.2.6 Interrupts

The OCM module is able to assert an interrupt signal to the APU under the following circumstances:

- Single-bit Parity Error
- Multiple-bit Parity Error
- Unsupported LOCK Request

All interrupts are enabled via the OCM.OCM_PARITY_CTRL register. Individual interrupt status is accessed via the OCM.OCM_IRQ_STS register, and cleared with a write of 1 to each bit location.

Parity on the RAM array is performed when the OCM.OCM_PARITY_CTRL[ParityCheckDis] is not asserted. When parity checking is enabled, a single- or multi-bit parity error sets the appropriate interrupt status, and triggers an external interrupt if the associated enable bit is set. The address offset of the first parity error is stored in the OCM.OCM_PARITY_ERRADDRESS register. For reads, a

SLVERR response can also be issued to the requesting master for devices that are unable to or prefer not to handle interrupts.

29.3 Register Overview

A partial list of registers related to the OCM is listed in [Table 29-7](#). (See [Appendix B, Register Details](#) for the complete list.)

Table 29-7: On-Chip Memory Register Overview

| Module | Register Name | Overview |
|--------|----------------------------------|---|
| OCM | OCM_PARITY_ERRADDRESS | Returns RAM parity error address |
| | OCM_PARITY_CTRL | Set interrupt enables, AXI read response error enable, parity enable, odd parity generation |
| | OCM_IRQ_STS | Read raw interrupt status, clear interrupts |
| | OCM_CONTROL | Change pre-arbitration priority |
| slcr | SLCR_LOCK | SLCR register write disable |
| | SLCR_UNLOCK | SLCR register write enable |
| | OCM_RST_CTRL | OCM subsystem reset |
| | TZ_OCM_RAM0/1 | OCM TrustZone |
| | OCM_CFG | Configures RAM address mapping |
| mpcore | SCU_CONTROL_REGISTER | SCU address filtering enable |
| | Filtering_Start_Address_Register | SCU address filtering base address |
| | Filtering_End_Address_Register | SCU address filtering end address |

29.4 Programming Model

29.4.1 Changing Address Mapping

A method for reorganizing the OCM address space and performing DDR remapping is as follows:

1. Complete all outstanding transactions by issuing data (DSB) and instruction (ISB) synchronization barrier commands.
2. Since the changing the address map may prevent the fetching of the nearby instructions, enable L1 instruction cache, and prefetch cache lines for the remainder of the function, typically with PLI instructions.
3. To facilitate prefetching, consider aligning the instructions to be prefetched to start at a cacheline boundary.
4. Ensure that the instruction prefetching has completed by issuing an ISB instruction.

5. Unlock the SLCR by writing the unlock key value to the slcr.SLCR_unlock register.
6. Modify the slcr.OCM_CFG register to change the address ranges that the RAM responds to.
7. Re-lock the SLCR by writing the lock key value to the slcr.SLCR_lock register, if desired.
8. Modify the mpcore.Filtering_Start_Address_Register to the desired start address of transactions that should be filtered away from the OCM for SCU masters. Typical settings are 0x0010_0000 (default, do not redirect lower 1 MB), and 0x0000_0000 (start redirect at lowest address to DDR RAM).
9. Modify the mpcore.Filtering_End_Address_Register to the desired end address of transactions that should be filtered away from the OCM for SCU masters. A typical setting is 0xFFE0_0000.
10. Set mpcore.SCU_CONTROL_REGISTER[Address_filtering_enable] to enable address filtering.
11. Ensure that the access has completed to the SLCR by issuing a data memory barrier (DMB) instruction. This allows subsequent accesses to rely on the new address mapping.

29.4.2 AXI Responses

The OCM module produces the following AXI responses:

| | |
|--------|--|
| OKAY | Generated for exclusive access transactions, indicating exclusive access failure. (OCM does not support exclusive access transactions). Also generated for all other successful transactions. |
| DECERR | Generated for TrustZone (TZ) violations when accessing RAM/BootROM. A TZ violation occurs when a non-secure AXI access (AxPROT[1] = 1) is attempted to a secure 4 KB region of RAM/BootROM (TZ operations occur at a 4 KB page granularity). |
| SLVERR | Generated for attempted access to reserved locations. SLVERR also generated for parity errors detected on RAM read access, if enabled. |

XADC Interface

30.1 Introduction

The Xilinx analog mixed signal module, referred to as the XADC, is a hard macro. It has JTAG and DRP interfaces for accessing the XADC's status and control registers in the 7-series FPGAs. Zynq-7000 SoC devices add a third interface, the PS-XADC interface for the PS software to control the XADC. The Zynq-7000 SoC devices combine a flexible analog-to-digital converter with programmable logic to address a broad range of analog data acquisition and monitoring requirements. The XADC is part of a larger analog mixed signal (AMS) topic that is a combination of analog and digital circuits.

The XADC has two 12-bit 1 mega samples per second (MSPS) ADCs with separate track and hold amplifiers, an analog multiplexer (up to 17 external analog input channels), and on-chip thermal and on-chip voltage sensors. The two ADCs can be configured to simultaneously sample two external-input analog channels. The track and hold amplifiers support a range of analog input signal types, including unipolar, bipolar, and differential. The analog inputs can support signal bandwidth of 500 KHz at sample rate of 1 MSPS. An external analog multiplexer can be used to increase the number of external channels supported without the cost of additional package pins.

The XADC optionally uses an on-chip reference circuit, thereby eliminating the need for external active components for basic on-chip monitoring of temperature and power supply rails. To achieve the full 12-bit performance of the ADCs, an external 1.25V reference IC is recommended.

The most recent measurement results (together with maximum and minimum readings) are stored in dedicated registers. User-defined alarm thresholds can automatically indicate over-temperature events and unacceptable power supply variation. A user-specified limit (for example, 100°C) can be used to initiate a software-controlled system power-down.

Control Interfaces

Software running in the PS can communicate with the XADC in one of two ways:

- PS-XADC Interface: a 32-bit APB slave interface on the PS interconnect that is FIFO'd and serialized.
- PS to PL AXI master could also be used to control the XADC via the AXI XADC core logic.

Development tools can connect to the PL-JTAG pins and control many parts of the SoC including the XADC. The interface is described in [Chapter 27, JTAG and DAP Subsystem](#). The PL-JTAG interface and the internal PS-XADC interface cannot be used at the same time. The selection between the these

interfaces is controlled by the `devcfg.XADCIF_CFG[ENABLE]` bit. However, the XADC arbitrates between the selected interface (PL-JTAG or PS-XADC) and the DRP interface.

System Considerations

For high-performance ADC applications managed by the PS, use the IP core Core Logic connected to an `M_AXI_GP` interface. This is a parallel data path. When using the PS-XADC interface, FIFOs are used for commands and read data to allow software to quickly queue-up commands without having to wait for serialization, but on the back end the data is serialized to the XADC much like the PL-JTAG interface. This is the serial datapath and is much slower.

30.1.1 Features

Analog-to-Digital Converters

- Dual 12-bit 1 MSPS analog-to-digital converters (ADCs)
- Up to 17 flexible and user-configurable analog inputs
- On-chip or external reference option
- On-chip temperature and power supply sensors
- JTAG access to ADC measurements

PS-XADC Interface

- Read and write XADC registers
- Serial data transfers to/from XADC
- Buffered read-write data operations
- 15-word by 32-bit command FIFO
- 15-word by 32-bit
- Read Data FIFO
- Programmable FIFO-level interrupts
- Programmable alarm interrupts
- Configured interface operations (using `devcfg` registers)
- When the PS-XADC interface is used, the PL-JTAG interface is disabled

DRP Parallel Interface

- Highest interface bandwidth
- 16-bit sample data

PL-JTAG Interface

- Access the XADC when the PL is not programmed but is powered-up

- Uses the JTAG TAP controller to access the XADC registers
- Enables JTAG access to all XADC registers including ADC measurements

30.1.2 System Viewpoint

The XADC is implemented in hard logic and resides in the PL power domain. The PS-XADC interface is part of the PS and can be accessed by the PS APU without the PL being programmed. The PL must be powered up to configure the PS-XADC interface, use the PL-JTAG or DRP interfaces, and to operate the XADC. A system level block diagram is shown in [Figure 30-1](#).

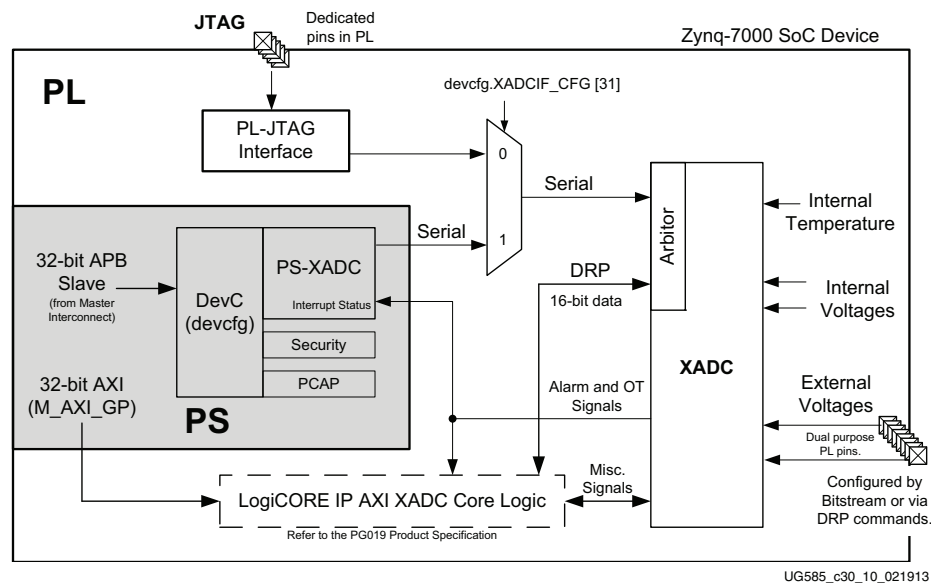

Figure 30-1: XADC Module System Viewpoint

Note: The XADC arbitrates between the DRP interface and either the PS-XADC or the PL-JTAG interface.

PS-XADC Interface

The PS-XADC interface description consumes the majority of this chapter. Software running in the PS configures the interface using the devcfg registers. Software writes commands to the interface that are pushed into the Command FIFO. These 32-bit writes, consisting of DRP command, address and data, are serialized and sent to the XADC in a loopback path that fills the returning Read Data FIFO that is read by the software.

The interface is configured by the devcfg registers, refer to [Appendix B, Register Details](#).

DRP Interface

The DRP interface is a parallel 16-bit bidirectional interface that can connect to a PL bus master via the LogiCORE IP AXI XADC PL logic using an AXI4-Lite interface to enable the PS or a MicroBlaze processor to control the XADC. The IP core receives 16 bits of data with each AXI4-Lite read/write transaction. The interface is described in [DS790, Product Specification](#).

The PL-AXI interface provides the highest performance. This interface uses the PL-AXI interface protocol and provides flexibility of integrating additional signal processing IPs in the data path of XADC's samples. For example, a FIR filter can be instantiated in the PL-AXI data path between the XADC and the M_AXI_GP interface of PS (or other logic in the PL).

PL JTAG Interface

The JTAG interface features and functions are described in [UG480, 7 Series FPGAs and Zynq-7000 SoC XADC Dual 12-Bit 1 MSPS Analog-to-Digital Converter User Guide](#). This interface connects to the development tools.

The Chipscope™ application can use the PL JTAG interface to read and write to the XADC status and control registers respectively.

Note: The PL-JTAG interface is disabled, including control by Chipscope, when the PS-XADC interface is selected.

Alarms

The seven alarm and over temperature signals are routed to the PS-XADC interface and made available to the PL. For the PS-XADC interface, these are described in section [30.3 PS-XADC Interface Description](#). Their use by the LogiCORE IP is described in [PG091, LogiCORE IP XADC Wizard Product Guide](#).

30.1.3 PS-XADC Interface Block Diagram

The block diagram for the PS-XADC interface is shown in [Figure 30-2](#).

The PS-XADC interface is normally controlled by software executing in the APU. The software writes 32-bit commands and NOPs to the command FIFO. The command FIFO output is serialized by the Serial Communications Channel in 32-bit packets for the XADC.

There is a programmable idle gap (IGAP) time between packets to allow time for the XADC to load read data in response to the previous packet. For every word shift out from the command FIFO, a corresponding word is shifted in to the Read Data FIFO. In the case of a DRP read command, as it is shifted out of the command FIFO, the old content of XADC_DRP's DR register is shifted out. After IGAP time, the result of the current DRP read is available in XADC DRP's DR register. When the next command from TXFIFO is shifted out, the result of the current read which is in the DR register, is shifted into the RDFIFO.

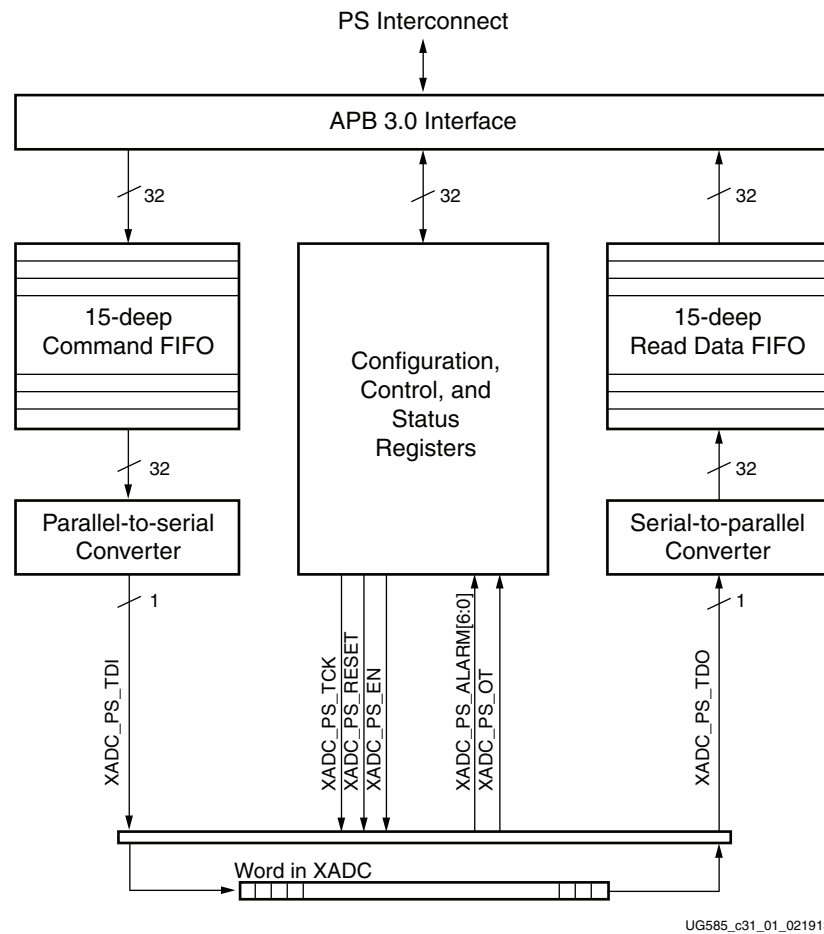

Figure 30-2: XADC PS-XADC Interface Block Diagram

30.1.4 Programming Guide

PS-XADC Interface

The programming model for the PS-XADC interface is described in [30.3 PS-XADC Interface Description](#).

DRP Interface

The programming model for the DRP interface is described in [UG480, 7 Series FPGAs and Zynq-7000 SoC XADC Dual 12-Bit 1 MSPS Analog-to-Digital Converter User Guide](#). This interface can connect to the LogiCORE IP AXI XADC interface to provide an AXI4-lite interface as described in the AXI XADC Interface product specification.

PL-JTAG Interface

The programming model for the PL-JTAG interface is described in [UG480, 7 Series FPGAs and Zynq-7000 SoC XADC Dual 12-Bit 1 MSPS Analog-to-Digital Converter User Guide](#).

Notices

7z007s and 7z010 CLG225 Devices

The 7z007s single core and 7z010 dual core CLG225 devices provide four external ADC signal pairs (differential inputs). All other Zynq-7000 devices provide 12 external ADC signal pairs. The hardware pin information is provided in [UG865, Zynq-7000 SoC Packaging and Pinout product Specification](#).

30.2 Functional Description

The system level block diagram is shown in [Figure 30-2, page 747](#). A block diagram of the XADC is provided in [UG480, 7 Series FPGAs and Zynq-7000 SoC XADC Dual 12-Bit 1 MSPS Analog-to-Digital Converter User Guide](#).

This section includes functionality that is common to more than one of the interfaces that can control the XADC. This content is not necessarily available in other documents:

- [30.2.1 Interface Arbiter \(PL-JTAG and PS-XADC\)](#)
- [30.2.2 Serial Communication Channel \(PL-JTAG and PS-XADC\)](#)
- [30.2.3 Analog-to-Digital Converter \(All\)](#)
- [30.2.4 Sensor Alarms \(PS-XADC and DRP\)](#)

30.2.1 Interface Arbiter (PL-JTAG and PS-XADC)

The XADC actively arbitrates requests between two of the three XADC interfaces. One of the interfaces is always the DRP interface that is optionally connected to the LogiCORE XADC bridge.

The interfaces that are arbitrated depend on the setting of the devcfg.XADCIF_CFG [ENABLE] bit.

- [ENABLE] = 0: DRP and PL-JTAG (reset default)
- [ENABLE] = 1: DRP and PS-XADC

If a JTAG transaction is in progress when a DRP request occurs, the LogiCORE XADC bridge can buffer the request until the JTAG transaction is complete. The XADC asserts the JTAGBUSY signal to indicate an ongoing JTAG transaction.

A JTAG transaction can start, but the DRP transaction in progress is allowed to complete before the JTAG operation. For more details on the arbitration, refer to [UG480, 7 Series FPGAs and Zynq-7000 SoC XADC Dual 12-Bit 1 MSPS Analog-to-Digital Converter User Guide](#).

30.2.2 Serial Communication Channel (PL-JTAG and PS-XADC)

The serial communication channel connects the XADC to the PS-XADC or PL-JTAG interface, depending on the `devcfg.XADCIF_CFG [ENABLE]` bit setting.

The channel is a full duplex synchronous bit-serial link with dedicated control signals using a JTAG protocol. By default, after reset, the connection between the PS and XADC (PS-XADC interface) is disabled. PS software can write a 1 to the `devcfg.XADCIF_CFG [ENABLE]` bit to control the source and switch the communication channel from the PL-JTAG interface to the PS-XADC interface. When the PS-XADC interface is enabled to control the XADC, the XADC is no longer accessible by the PL-JTAG interface. The inverse is true, when XADC is accessible by PL-JTAG, it can not be accessed by the PS-XADC.

The PS-XADC interface interacts with the PS via an APB 3.0 interface on the PS interconnect. This interface is part of the DevC module and is described in section [6.4 Device Boot and PL Configuration](#).

30.2.3 Analog-to-Digital Converter (All)

The functions and features of the XADC are described in [UG480, 7 Series FPGAs and Zynq-7000 SoC XADC Dual 12-Bit 1 MSPS Analog-to-Digital Converter User Guide](#).

30.2.4 Sensor Alarms (PS-XADC and DRP)

The XADC can generate an alarm signal when an internal sensor measurement exceeds the value programmed into the XADC threshold register. The alarm thresholds are stored in the XADC Control registers, refer to [UG480](#) for their descriptions.

PS-XADC Interface

The alarm signals are routed directly from the XADC block into the PS_XADC interface block, thus allowing alarm status to be reflected directly in the PS XADC's interface registers and enabling alarms to trigger interrupts.

Individual alarm interrupts can be disabled using the `devcfg.XADCIF_INT_MASK` register.

The alarm signals are sent to the PS-XADC Interface Status register. This register is masked and the masked interrupts are OR'd together to generate the IRQ ID #39 interrupt to the PS interrupt controller.

When an alarm goes active, it triggers a maskable interrupt. The alarm signals get latched in the PS-XADC interface `devcfg.XADCIF_INT_STS` register and it can be used to determine which alarm was activated. Writing a 1 to the active alarm bit in the `devcfg.XADCIF_INT_STS` register clears the interrupt. The unmasked status of the alarm signals can be read using the `devcfg.XADCIF_MSTS` register.

DRP Interface

The alarms and OT signals are available on the DRP interface. They are actively connected to and used by the LogiCORE AXI_XADC bridge, refer to [PG019](#), *LogiCORE IP AXI XADC Product Guide*.

Functional Description

When the measured value on a voltage sensor is greater than the maximum thresholds or less than the minimum threshold values, then the output alarm signal goes active. The alarm is reset (inactive) when a subsequent measurement value falls between the upper and lower threshold values.

This operation differs for the temperature sensor alarm, The temperature alarm goes active when the measured temperature exceeds the high threshold. The temperature alarm is reset (inactive) when the temperature falls below the lower threshold value.

The alarm signals are summarized in [Table 30-1](#).

Table 30-1: XADC Alarm Signals

| Alarm | Description | Upper/Lower Threshold Control and Maximum/Minimum Status Registers |
|--------|---|---|
| ALM[0] | Programmable Temperature sensor alarm | Refer to the LogiCORE User Guide sections: <ul style="list-style-type: none"> • Maximum and Minimum Status Registers • Automatic Alarms |
| ALM[1] | V _{CCINT} sensor alarm (PL internal voltage) | |
| ALM[2] | V _{CCAUX} sensor alarm (PL auxiliary voltage) | |
| ALM[3] | V _{CCBRAM} sensor alarm (PL BRAM voltage) | |
| ALM[4] | V _{CCPINT} sensor alarm (PS internal voltage) | |
| ALM[5] | V _{CCPAUX} sensor alarm (PS auxiliary voltage) | |
| ALM[6] | V _{CCO_DDR} sensor alarm (PS DDR I/O voltage) | |
| OT | Over-temperature Alarm | |

30.3 PS-XADC Interface Description

The main function of the PS-XADC interface is to serialize commands written by software before sending them to the XADC, and to perform a serial-to-parallel conversion when serial data is received from the XADC for the software to read.

30.3.1 Serial Channel Clock Frequency

The serial communications channel between the PS-XADC interface and the XADC should not be clocked faster than 50 MHz. The serial clock is derived from the PCAP_2x clock generated by the PS clock subsystem (refer to [Chapter 25, Clocks](#)). This clock has a nominal frequency of 200 MHz. A configurable clock divider is controlled by the devcfg.XADCIF_CFG [TCLK_RATE] bit field to reduce the PCAP_2x clock frequency to no more than 50 MHz.

$$\text{XADC serial clock} = \text{PCAP}_2\text{x clock} / [\text{TCLK_RATE}]$$

The XADC serial clock drives the DCLK that is described in the LogiCORE User Guide.

30.3.2 Command and Data Packets

The PS-XADC interface buffers the 32-bit reads and writes to minimize the effects of the slow serial transfer process on PS system throughput. The PS-XADC interface buffers up to 15 commands. Each command is serialized and communicated to the XADC. For every command that is written to the PS-XADC interface, a data word is received in the Read Data FIFO. The Read Data FIFO can store 15 data words. Up to 15 commands at a time to be written and up to 15 read data words can be in FIFOs. After a read command has been written, the corresponding read data is available after the next command is serialized to the XADC, see [Figure 30-3](#). Therefore, if the last command in CMD FIFO is a read command, one additional NOP command is always needed to push out the last read data.

The XADC commands are listed in the LogiCORE user guide and in [UG480, 7 Series FPGAs and Zynq-7000 SoC XADC Dual 12-Bit 1 MSPS Analog-to-Digital Converter User Guide](#).

All control commands, read requests, write requests, and NOPs shift data into the Read Data FIFO that can be read using the devcfg.XADCIF_RD_FIFO register. The software controlling the PS-XADC interface should account for this and should read and discard data not generated by a read command. XADC read data is 32-bits but only the 16 LSBs of the 32-bit word contain ADC data.

PS-XADC Event Timing

- Command register write
- Serialized to XADC (control and data)
- Programmable idle gap width, devcfg.XADCIF_CFG [IGAP]

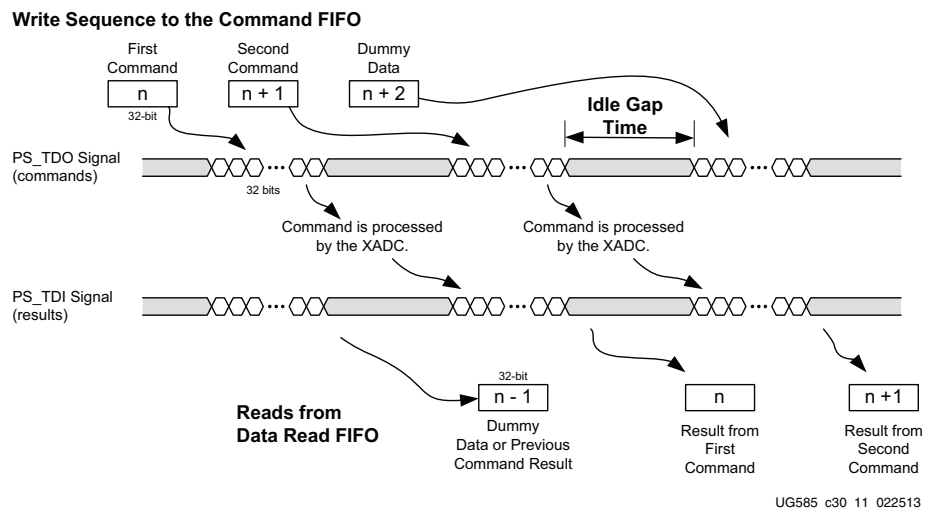

Figure 30-3: XADC PS-XADC Interface Event Timing Diagram

The status of the command and Read Data FIFOs can be monitored using the devcfg.XADCIF_MSTS Interface Miscellaneous Status register. Software can also setup interrupts using the devcfg.XADCIF_INT_STS Interrupt Status register.

Note: Reading from an empty Read Data FIFO causes an APB slave bus error.

One packet remains in the XADC when the Command FIFO is emptied. To retrieve the packet, write a dummy command.

30.3.3 Command Format

Figure 30-4 shows the data format of the PS-XADC interface commands. The first 16 LSBs of the XADCIF_CMD_FIFO contain the DRP register data. For both read and write operations, the address bits, XADCIF_CMD_FIFO [25:16], hold the DRP target register address. The command bits, XADCIF_CMD_FIFO [29:26], specify a read, write, or no operation (see Table 30-2).

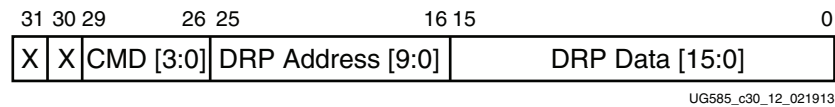

Figure 30-4: PS-XADC Interface Command Register

Table 30-2: PS-XADC Interface DRP Command Format

| CMD [3:0] | | | | Operation |
|-----------|---|---|---|--------------|
| 0 | 0 | 0 | 0 | No operation |
| 0 | 0 | 0 | 1 | DRP read |
| 0 | 0 | 1 | 0 | DRP Write |
| Others | | | | Not defined |

DPR Address and DRP Data

The full list of XADC DRP registers and instructions on how to configure them can be found in the [UG480, 7 Series FPGAs and Zynq-7000 SoC XADC Dual 12-Bit 1 MSPS Analog-to-Digital Converter User Guide](#).

30.3.4 Read Data Format

The XADC data is returned in the lower 16 bits of the devcfg.XADCIF_RDFIFO register read. The interpretation of the DRP data can be found in the UG480 LogiCORE User Guide.

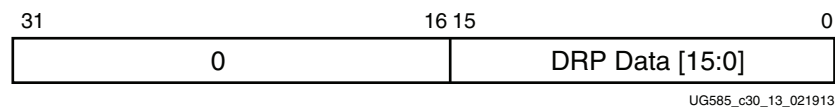

Figure 30-5: PS-XADC Interface Read Data Format

30.3.5 Min/Max Voltage Thresholds

The XADC tracks the minimum and maximum values recorded for the internal supply sensors since the last power-up or the last reset of the XADC control logic. The maximum and minimum values recorded are stored in the DRP Status registers. On power-up or after reset, all Minimum registers are set to `FFFFh` and all Maximum registers are set to `0000h`. Each new measurement generated for an on-chip sensor is compared to the contents of its Maximum and Minimum register. If the measured value is greater than the contents of its Maximum register, the measured value is written to the Maximum register. Similarly, for the Minimum register, if the measured value is less than the contents of its Minimum register, the measured value is written to the Minimum register. This check is carried out each time a measurement result is written to the Status register.

30.3.6 Critical Over-temperature Alarm

Note: This feature sends an interrupt status to the PS and causes an automatic shutdown feature for the PL side of the Zynq-7000 device if enabled. The PL shutdown is enabled via the bitstream and the PL will only come out of power-down if the over-temperature alarm goes inactive or a reconfiguration occurs.

The on-chip temperature measurement is used for critical temperature warnings. The default *over temperature* threshold is 125°C. This threshold is used when the contents of the OT Upper Alarm register (listed in UG480) have not been configured. When the die temperature exceeds the threshold set in the XADC's Control register, the over-temperature alarm (OT) becomes active. The OT signal resets when the die temperature has fallen below set threshold.

The OT alarm can also be used to automatically power down the PL upon activation. The OT alarm can be disabled by writing a 1 to the OT bit in the XADC's Configuration register.

Note: these registers are in the XADC and are accessible using the DRP.

The XADC OT alarm signal is sent to the PS via the dedicated PS-XADC interface. When the OT alarm goes active it triggers a maskable interrupt. The OT bit of the XADCIF_INT_STS register needs to be cleared by writing a 1 to the bit location. The real time value of the OT alarm signal can be found on the XADCIF_MSTS register.

30.4 Programming Guide for the PS-XADC Interface

The following sequence describes how to configure and interact with the PS-XADC interface to read an internal VCC auxiliary PS voltage (V_{CCPAUX}) and raise an Alarm interrupt when V_{CCPAUX} value does not fall between higher and lower thresholds. The PS-XADC interface specifies commands to be sent in a specific format as described in section 30.3.3 [Command Format](#). Refer to detailed examples in section 30.4.3 [Command Preparation](#).

Example: Initialization of XADC via the PS-XADC Interface

This example resets the communications channel and the XADC. It also flushes the FIFOs; leaving a NOOP (dummy) word in the XADC.

1. **Reset the serial communication channel.** Write a 1 and then a 0 to devcfg.XADCIF_MCTL [RESET].
2. **Reset the XADC.** Write any 16-bit value to DRP address 0x03 (reset register). Write 08030000h to the devcfg.XADCIF_CMDFIFO register.
3. **Flush the FIFOs.** There is no reset signal, instead write 15 NOOPs to the FIFO:
 - a. Wait for the Command FIFO to empty. The last command should be a NOOP (dummy write).
 - b. Read the Read Data FIFO until empty.

Example: Start-up Sequence via the PS-XADC Interface

This example sets various interface parameters and includes steps for interrupts and data transfers. It assumes the interface and the XADC are already initialized.

1. **Configure the PS-XADC interface:** Program the configuration register. Write 80001114h into the devcfg.XADCIF_CFG register:
 - a. Use default Minimum idle gap, [IGAP] = 14h (20 serial clocks).
 - b. Use default XADC serial clock frequency to 1/4 of PCAP_2x clock frequency, [TCKRATE] = 01.
 - c. Use default FIFO serial read capture edge (rising), [REDGE] = 1.
 - d. Use default FIFO serial write launch edge (falling), [WEDGE] = 0.
 - e. Use default Read Data FIFO threshold level, [DFIFOTH] = 0x0.
 - f. Use default Command FIFO threshold level, [CFIFOTH] = 0.
 - g. Enable the PS access of XADC. Write 0x1 to devcfg.XADCIF_CFG [ENABLE].
2. **Configure the interrupts:** Interrupts are used to manage the alarms from the XADC and Command/Read Data FIFOs. Refer to the program example in section [30.5.3 Interrupts](#).
3. **Data transfers to the XADC:** Refer to section [30.5.2 Read and Write FIFOs](#).

30.4.1 Read and Write to the FIFOs

This example configures the devcfg.XADCIF_CFG register for the FIFOs and communications channel. This register controls the command and Read Data FIFO thresholds, the clock rate of the XADC_PS_TCK, the clocking edges for the serial bus and the idle gap between serial packets.

After power on Command and Read Data FIFOs of the PS-XADC interface are empty, but must be flushed after an XADC interface reset. Commands for writing to or reading from XADC registers are sent to the XADC using the Command FIFO, and data returned from the XADC is collected in the Read Data FIFO.

Example: Write Command to the XADC

This example writes to the XADC V_{CCPAUX} Alarm Upper threshold register.

1. **Prepare command.** Prepare the command as described in section [30.4.3 Command Preparation](#) for writing to the XADC V_{CCPAUX} Alarm Upper threshold register (0x5A) with required threshold.
2. **Fill the Command FIFO with data.** Write the data formatted in step 1 to the devcfg.XADCIF_CMDFIFO register.

3. **Wait until the Command FIFO becomes empty.** Wait until `devcfg.XADCIF_MSTS [CFIFOE] = 1`.

Note: For every write to the `devcfg.XADCIF_CMDFIFO` register, data is shifted into the `devcfg.XADCIF_RDFIFO` register (Read Data FIFO).

Example: Read the V_{CCPAUX} value from the XADC

This example reads the current V_{CCPAUX} value from the XADC V_{CCPAUX} status register.

1. **Prepare command.** Prepare the command as described in section 30.4.3 [Command Preparation](#) for reading the XADC V_{CCPAUX} Status register (0x0E).
2. **Write data to Command FIFO.** Write data formatted in step 1 to the `devcfg.XADCIF_CMDFIFO` register.
3. **Wait until the Command FIFO becomes empty.** Wait until `devcfg.XADCIF_MSTS [CFIFOE] = 1`.
4. **Read dummy data from the Read Data FIFO.** Read the `devcfg.XADCIF_RDFIFO` register.
5. **Format data.** Prepare Command for No operation as described in 30.4.3 [Command Preparation](#).
6. **Write data to the Command FIFO.** Write the formatted data in step 5 to the `devcfg.XADCIF_CMDFIFO` register.
7. **Read the Read Data FIFO.** Read the `devcfg.XADCIF_RDFIFO` register.

Note: After a read command has been sent to the XADC, the corresponding read data will be available during the next shift period. Therefore, one dummy command write (as shown in step 5) is always needed to push out the last read data.

30.4.2 Interrupts

Example: Configure and Manage Alarm 5 (V_{CCPAUX})

This example configures the XADC registers to set alarm thresholds, operating mode, and enables the Alarm 5 (V_{CCPAUX}) interrupt in the PS-XADC interface. The XADC hard macro has to be operated in Independent mode because alarms are not enabled in Default mode (refer to the XADC Operating Modes section of [UG480, 7 Series FPGAs and Zynq-7000 SoC XADC Dual 12-Bit 1 MSPS Analog-to-Digital Converter User Guide](#)).

1. **Prepare commands.** Prepare commands as described in section 30.4.3 [Command Preparation](#) for writing to the XADC hard macro alarm threshold registers (V_{CCPAUX} Upper-0x5A and V_{CCPAUX} Lower-0x5E) with the required thresholds and XADC Config_Reg1 (0x41) to set the XADC in Independent mode.
2. **Write commands to the Command FIFO.** Write the commands prepared in step 1 to the `devcfg.XADCIF_CMDFIFO` register.
3. **Enable the Alarm 5 interrupt in the PS-XADC interface.** Write `devcfg.XADCIF_INT_MASK [M_ALM] = 7Eh`.
4. **Check if Alarm 5 is triggered.** Poll for `devcfg.XADCIF_INT_STS [M_ALM] = 1`.
5. **Clear the Alarm 5 interrupt.** Write `devcfg.XADCIF_INT_STS [M_ALM] = 1`.
6. **Disable the Alarm 0 interrupt.** Write `devcfg.XADCIF_INT_MASK [M_ALM] = 7Fh`

30.4.3 Command Preparation

Example: Prepare Data for Writing to the XADC Register

This example formats data for writing to XADC Configuration Register 1 to set the XADC in Independent mode. Refer to [Table 30-2, page 752](#).

1. **DRP data.** Data to set the XADC in independent mode is 8000h. Refer to the XADC Register Interface section of [UG480](#).
2. **DRP address.** The address of the XADC Configuration Register 1 is 0x41.
3. **Write command.** The command for a write operation is 0010b.

The command to write 8000h in XADC Configuration Register 1 (0x41) is 08418000h.

Example: Prepare Data for Reading from the XADC Register

This example formats data for reading the XADC V_{CCPAUX} Status register, 0x0E.

1. **DRP data.** Data can be any arbitrary data for the read operation (0).
2. **DRP address.** The address of the XADC V_{CCPAUX} Status register is 0x0E.
3. **Write command.** The command for a read operation is 0001b.

The command to read the XADC V_{CCPAUX} Status register, 0x0E, is 040E0000h.

30.4.4 Register Overview

An overview of the PS-XADC Interface control registers is shown in [Table 30-3](#). Register bit details are provided in [Appendix B, Register Details](#). Refer to the XADC Register Interface section of UG480 LogiCORE User Guide for register details of the XADC.

Note: After power-up (refer to the Zynq-7000 SoC data sheet for the proper voltage sequencing), PS-to-PL voltage shifters are automatically enabled. The PL must be powered-up to access the PS-XADC interface registers, but the PL does not need to be configured to access the registers.

[Table 30-3](#) shows an overview of XADC Interface registers.

Table 30-3: Register Overview

| Function | Mnemonic | Description | Type |
|---------------|------------------------|--|------------------------|
| Configuration | devcfg.XADCIF_CFG | Configuration: Enable, FIFO threshold, frequency ratio, and launch edge. | Read/Write |
| | devcfg.XADCIF_MCTL | XADC Interface Misc. Control register | Read/Write |
| Interrupts | devcfg.XADCIF_INT_STS | XADC Interface Interrupt Status register | Read, Write 1 to clear |
| | devcfg.XADCIF_INT_MASK | XADC Interface Interrupt Mask register | Read/Write |
| | devcfg.XADCIF_MSTS | XADC Interface Misc. Status register | Read |

Table 30-3: Register Overview (Cont'd)

| Function | Mnemonic | Description | Type |
|-----------------------------|-----------------------|-------------------------------|-------|
| Command and Read Data FIFOs | devcfg.XADCIF_CMDFIFO | XADC Interface Command FIFO | Write |
| | devcfg.XADCIF_RDFIFO | XADC Interface Read Data FIFO | Read |

30.5 Programming Guide for the DRP Interface

The XADC can also be accessed by instantiating a LogiCORE AXI XADC bridge in the PL. This method provides more powerful features and easy access to all XADC registers and signals using a register read/write programming model for microprocessors.

30.6 Programming Guide for the PL-JTAG Interface

The PS-XADC interface commands are similar to the JTAG DRP commands. Refer to the JTAG DRP commands shown in [UG480, 7 Series FPGAs and Zynq-7000 SoC XADC Dual 12-Bit 1 MSPS Analog-to-Digital Converter User Guide](#).

Note: PL-JTAG cannot access the XADC if the PS-XADC interface is accessing the XADC (i.e., devcfg.XADCIF_CFG [ENABLE] = 1).

30.7 System Functions

30.7.1 Clocks

Clocking is determined by the interface choice.

PS-XADC Interface Clocks

1. The PS-XADC interface uses FIFOs to cross between the PS system clock and the XADCIF clock.
2. PS system interface clock is the CPU_1x clock.
3. The XADCIF clock frequency is the PCAP_2x clock / [TCLKRATE].
 - a. The XADCIF clock maximum frequency is 50 MHz.
 - b. The PCAP_2x clock frequency is nominally 200 MHz.
 - c. The [TCLKRATE] bit: divide 2, 4 (default), 8, or 16.

See [Chapter 25, Clocks](#) for more information about the PS clocks.

DRP Interface Clocks

The PL-AXI interface is a soft core instantiated within the PL and uses a clock from one of the PL's PLLs.

PL-JTAG Interface Clocks

PL-JTAG uses the JTAG port to interface with the XADC and uses the JTAG clock, TCK.

30.7.2 Resets

There are several resets in the XADC module.

PS-XADC Interface Reset

The PS-XADC interface and its serial communication channel to the XADC are reset using `devcfg.XADCIF_MCTL [RESET]`.

Note: The PS-XADC FIFOs are not cleared by the interface reset.

XADC Reset

The XADC is reset by writing to the reset register using a DRP address of `03h`. Write `0x08030000` to the `devcfg.XADCIF_CMDFIFO` register. The data that is included is ignored by the XADC.

PCI Express

31.1 Introduction

The Zynq-7000 7z012s, 7z015, 7z030, 7z035, Zynq-7z045, and Zynq-7z100 SoC devices include the Xilinx 7 series Integrated block for PCI Express core which is a reliable, high-bandwidth, third-generation I/O solution.

The PCI Express solution for these Zynq SoC devices supports x1, x2, x4, and x8 lane Root Port and Endpoint configurations at up to 5 Gb/s (Gen2) speed. Attention must be paid to system level bandwidth if full Gen 2 – x8 throughput is needed. This might include either inline processing of the data in PL before storing it to the PS DDR memory or using a wider DDR3 memory interface in the PL. The Root Port configuration can be used to build a Root Complex solution. These configurations are compatible with the PCI Express Base Specification, Rev 2.1.

The PCI Express module supports the AXI4-stream interface for the user interface at both 64-bit and 128-bit widths.

For more detailed information regarding the 7 Series FPGAs Integrated block for PCI Express core, refer to these documents on the Xilinx website:

- [PG054](#), *7 Series FPGAs Integrated Block for PCI Express LogiCORE IP Product Guide*
- [PG055](#), *AXI Memory Mapped to PCI Express (PCIe)Gen2 LogiCORE IP Product Guide*

31.2 Block Diagram

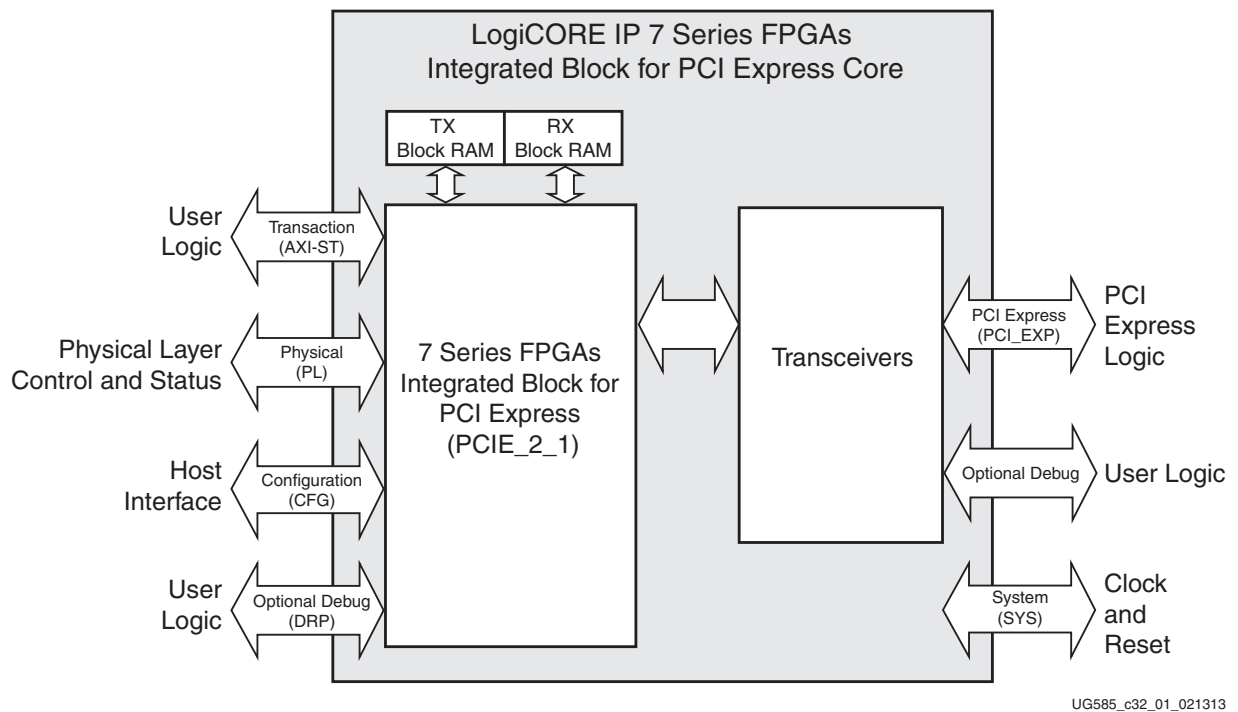

Figure 31-1: PCI Express Block Diagram

For additional information regarding the different interfaces to the Integrated block for PCI Express core, refer to [PG054](#), *7 Series FPGAs Integrated Block for PCI Express LogiCORE IP Product Guide*.

31.3 Features

The PCI Express core provides these key features:

- High-performance, highly flexible, scalable, and reliable, general-purpose I/O core
 - Compatible with the PCI Express Base Specification, rev. 2.1
 - Compatible with conventional PCI software model
- Incorporates Xilinx® Smart-IP™ technology to guarantee critical timing
- Uses GTXE2 transceivers for 7 Series FPGA families
 - 2.5 Gb/s and 5.0 Gb/s line speed
 - Supports 1-lane, 2-lane, 4-lane, and 8-lane operation
 - Elastic buffers and clock compensation
 - Automatic clock data recovery

- Supports Endpoint and Root Port configurations
- 8B/10B encode and decode
- Supports lane reversal and lane polarity inversion per PCI Express specification requirements
- Standardized user interface
 - Supports AXI4-stream interface
 - Easy-to-use packet-based protocol
 - Full-duplex communication
 - Back-to-back transactions enable greater link bandwidth utilization
 - Supports flow control of data and discontinuation of an in-process transaction in transmit direction
- Supports flow control of data in receive direction
- Compatible with PCI/PCI Express power management functions
- Supports a maximum transaction payload of up to 1,024 bytes
- Supports multi-vector MSI for up to 32 vectors and MSI-X
- Up-configure capability enables application-driven bandwidth scalability
- Compatible with PCI Express transaction ordering rules

31.4 Endpoint Use Case

For an example of a Zynq Endpoint use case, refer to [UG963](#), *ZC706 PCIe Targeted Reference Design User Guide*.

31.5 Root Complex Use Case

A Zynq PCIe Root Complex design can be implemented in a number of different ways. [Figure 31-2](#) shows an example of a basic design using the AXI PCIe bridge described in [PG055](#), *LogiCORE IP AXI Bridge for PCI Express*.

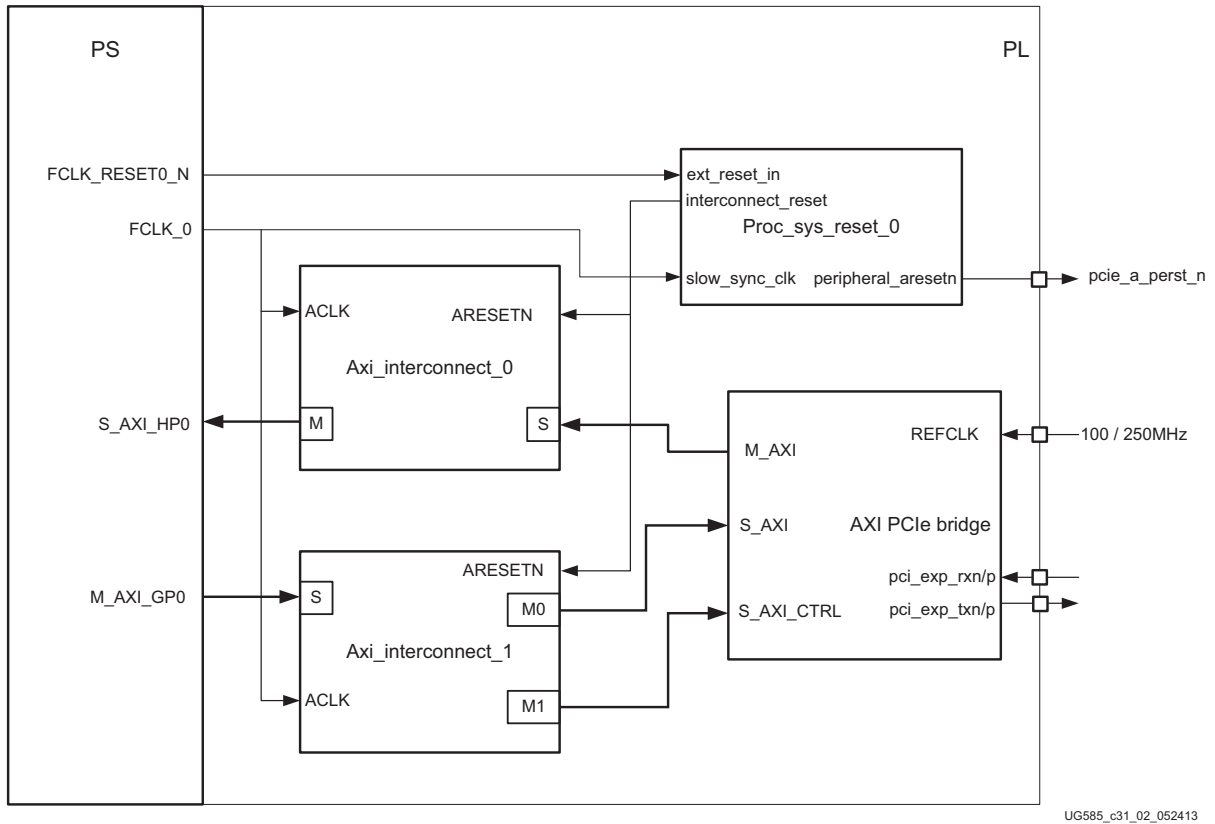

Figure 31-2: Example Zynq PCIe Root Complex

Note: The AXI PCIe bridge master and slave ports are connected to separate AXI interconnects to avoid potential deadlock scenarios.

The compiled Linux kernel already has the required AXI PCIe bridge driver enabled, so no additional configuration is needed. Software drivers for the connected endpoint device might need to be installed.

For information on building the Linux kernel for Zynq, refer to the [Xilinx Zynq Linux Wiki](https://www.xilinx.com/support/answers/69022.html).

Device Secure Boot

32.1 Introduction

Zynq-7000 SoC devices support the ability to perform a secure boot to load authenticated and encrypted PS images and PL bitstreams.

Note: The BootROM Header is referred to as the Boot Image Header in [UG821](#), *Zynq-7000 SoC Software Developers Guide*. They both refer to the same table of parameters provided in [Table 6-5](#).

32.1.1 Block Diagram

[Figure 32-1](#) is a block diagram showing the different systems involved in a secure boot.

32.1.2 Features

Zynq-7000 SoC devices provide the following secure boot features:

- Advanced Encryption Standard
 - AES-CBC with 256-bit key (FIPS197)
 - Encryption key stored on-chip in either eFuse or Battery-backed RAM (BBRAM)
- Keyed-hashed message authentication code (HMAC, FIPS198-1)
 - SHA-256 authentication engine (FIPS180-4)
- RSA public key authentication (FIPS186-3)
 - 2048-bit public key

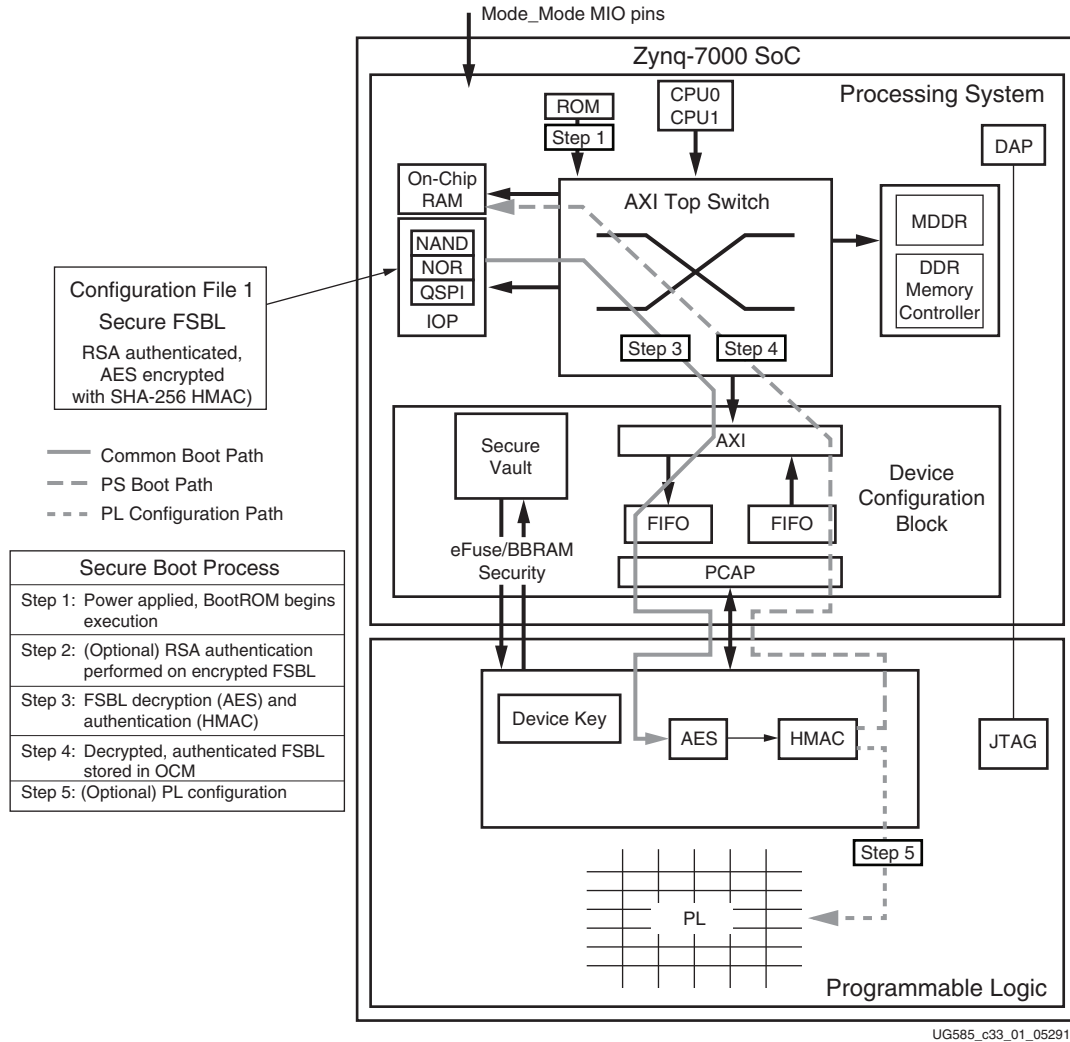

Figure 32-1: Secure Boot Block Diagram

A device secure boot involves several systems contained within the SoC device. The secure boot process is always initiated by the BootROM. If RSA authentication has been enabled the BootROM will use the public key to authenticate the first stage boot loader (FSBL) before it is decrypted or executed. If the boot image header indicates a secure boot, the BootROM enables the AES and HMAC engines which reside in the PL. The encrypted FSBL is then sent by the BootROM to the AES and HMAC, a hardened core within the PL, via the processor configuration access port (PCAP). The FSBL image is decrypted and sent back to the PS via the PCAP where it is loaded into the on-chip RAM (OCM) for execution. The PS is then able to securely configure the PL by sending an encrypted bitstream through the PCAP to the AES/HMAC for decryption, authentication, and distribution to the PL memory cells.

32.2 Functional Description

32.2.1 Master Secure Boot

Master secure boot is the only secure boot mode supported in Zynq-7000 SoC devices. It uses the hardened AES decryption engine and the hardened HMAC authentication engine within the PL to decrypt PS images and PL bitstreams. If RSA authentication is enabled, the BootROM authenticates the encrypted FSBL using the public key prior to decryption (see [Table 32-3](#)). The boot process for the master secure boot mode is shown in [Figure 32-2](#).



IMPORTANT: *The master secure boot mode uses the AES decryption and HMAC authentication engines within the PL, therefore the PL must be powered on during the secure boot process. The BootROM ensures that the PL is powered before reading the encrypted image from the external boot device. It is the user's responsibility to ensure that the PL is powered on before trying to decrypt any new configuration files.*

Power on Reset

After the power-on and reset sequences have completed, the on-chip BootROM begins to execute. An optional eFuse setting can be used to perform a full 128 KB CRC on the BootROM for a small boot time penalty (around 25 ms at default boot settings). After the integrity check the BootROM reads the boot mode setting specified by the bootstrap pins. The BootROM code then reads the BootROM header from the specified external memory.

RSA Authentication Performed on FSBL

If RSA authentication is enabled the BootROM loads the boot image header (including the Register Initialization parameters) and the FSBL into the first 192 KB of the OCM. Next the public key is loaded from the boot image (see section [32.2.3 Secure Boot Image](#)) and validated by calculating a SHA-256 signature and comparing it to the hash value stored in eFuse. If the values match, the BootROM calculates the signature for the FSBL and authenticates it with the public key. If the public key signature does not match the hash value stored in eFuse or the authentication fails on the FSBL, the BootROM performs a fallback and searches for a new FSBL if the boot device is NAND, NOR, or QSPI. If the fallback fails or the boot device is SD, the BootROM enters either an error state and enables JTAG or enters a secure lockdown if the boot image was encrypted. If the authentication of the FSBL passes, the BootROM continues the boot process. For more details see section [32.2.5 RSA Authentication](#).

Secure FSBL Decryption

If a secure boot is specified in the boot image header, the BootROM starts by checking the power-on status of the PL. Since the AES and HMAC engines reside within the PL, the PL must be powered up to perform a secure boot. The BootROM waits until the PL is powered up before continuing the secure boot sequence. After the power-on status of the PL is confirmed, the BootROM begins to load the encrypted FSBL into the AES engine via the PCAP. The PL sends the decrypted FSBL back to the PS via the PCAP. The decrypted image is then loaded into the OCM. The BootROM also monitors the HMAC

authentication status of the FSBL and if an authentication error occurs, the BootROM puts the PS into a secure lockdown state.

Handoff to FSBL

Once the FSBL has been successfully loaded and authenticated, control is turned over to the decrypted FSBL which now resides in the OCM. Based on the user application, the FSBL could then start processing, configure the PL, load additional software, or wait for further instruction from an external source.

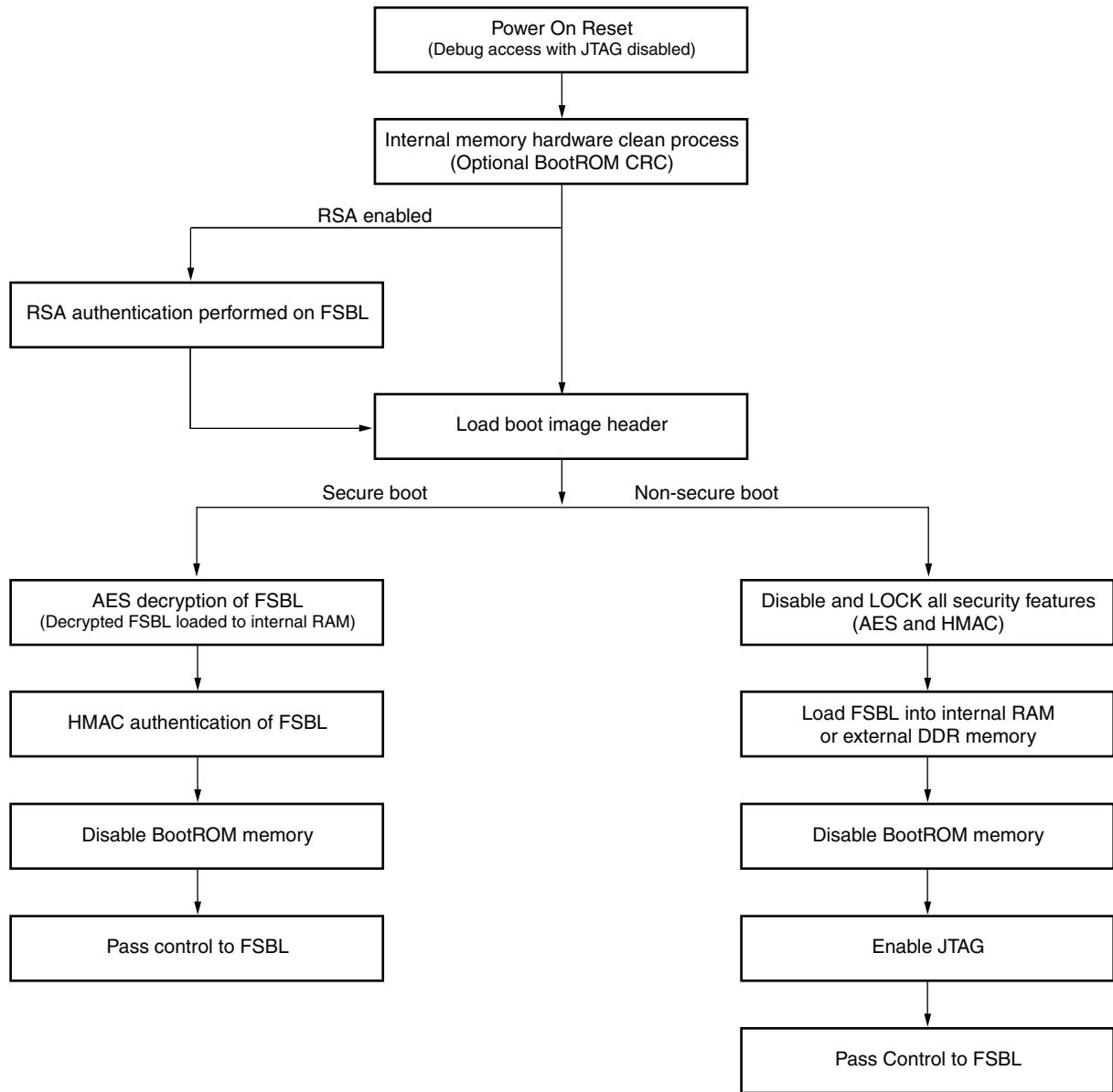

UG585_c33_02_100917

Figure 32-2: PS Boot Flow

32.2.2 External Boot Devices

Secure boot mode is restricted to NOR, NAND, SDIO, or Quad-SPI flash as the external boot device. A secure boot from JTAG or any other external interface is not allowed.

32.2.3 Secure Boot Image

The secure boot image format is shown in [Figure 32-3](#). The secure boot image consists of a boot image header (required), a FSBL partition (required), a FSBL RSA authentication certificate (optional), and any number, including zero, of succeeding partitions.

Boot Image Header

The boot image header identifies the image as secure or non-secure at offset 0x028. The value stored in the boot image header at offset 0x028 determines the AES key source (see [Table 32-1](#)). More information regarding the boot image header can be found in [Chapter 6, Boot and Configuration](#).

Table 32-1: BootROM Header Summary

| BootROM Header Value at 0x028 | Description |
|-------------------------------|---------------------------------|
| 0xA5C3C5A3 | Encrypted image using eFuse key |
| 0x3A5C3C5A | Encrypted image using BBRAM key |
| All others | Non-encrypted image |

The boot image header is never encrypted.

Note: The two terms, BootROM header and BootROM image header are synonymous and both refer to the same table of parameters, [Table 6-5](#).

Partition Data

Partition data is signed and encrypted. The partition data is decrypted and authenticated by the AES and HMAC engines within the PL.

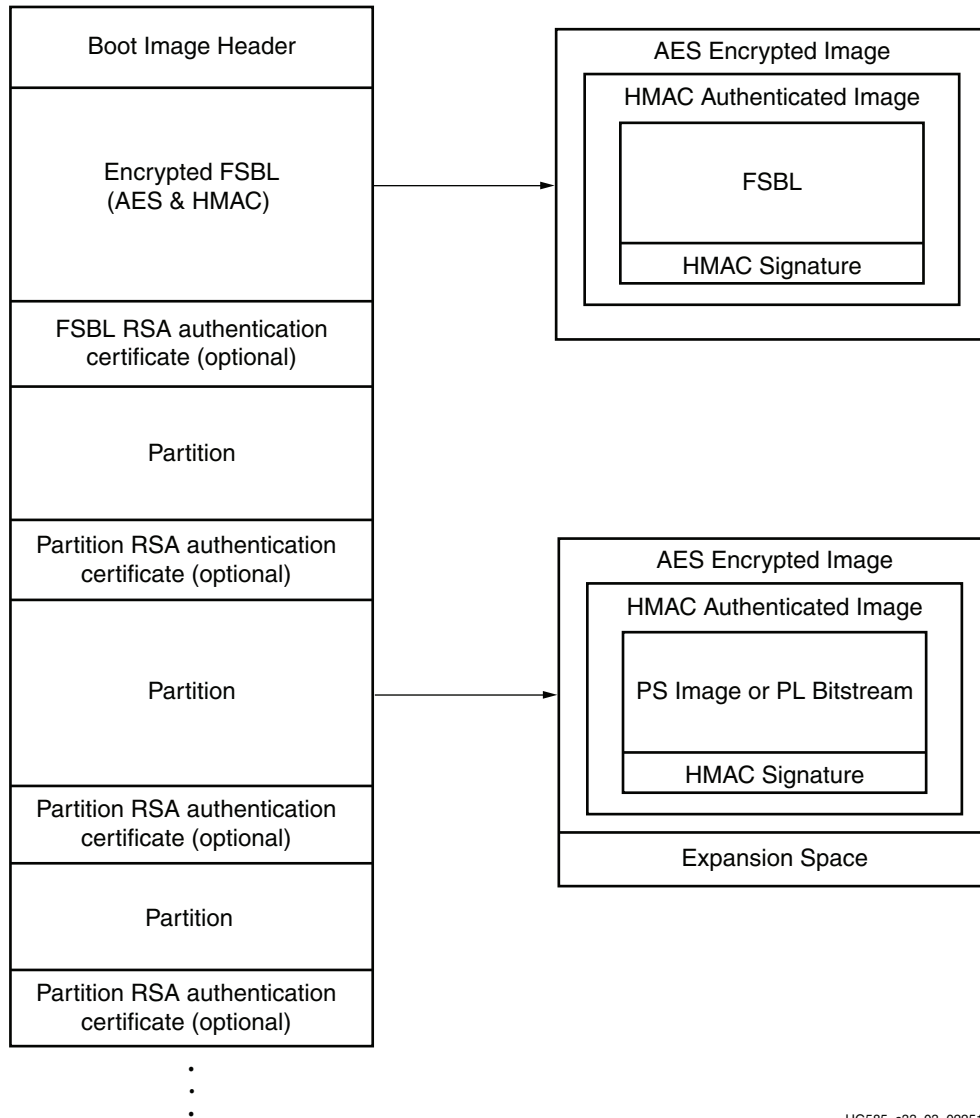

UG585_c33_03_022513

Figure 32-3: Secure Boot Image Format

RSA Authentication Certificate Format

The RSA authentication certificate consists of three major components; the authentication header, the PPK and SPK, and the SPK and FSBL signatures (see Figure 32-4). The authentication header is 32-bits with the following value 0x00000101, padded to a 512-bit boundary. Each public key consists of three parts, a 2,048-bit modulus, a 2,048-bit modulus extension to speed up calculations, and a 32-bit public exponent which gets padded to 512 bits. The other component is the 2,048-bit SPK and FSBL signatures. Since SHA-256 is used as the secure hash algorithm, the FSBL, partition, and authentication certificates must be padded to a 512-bit boundary.

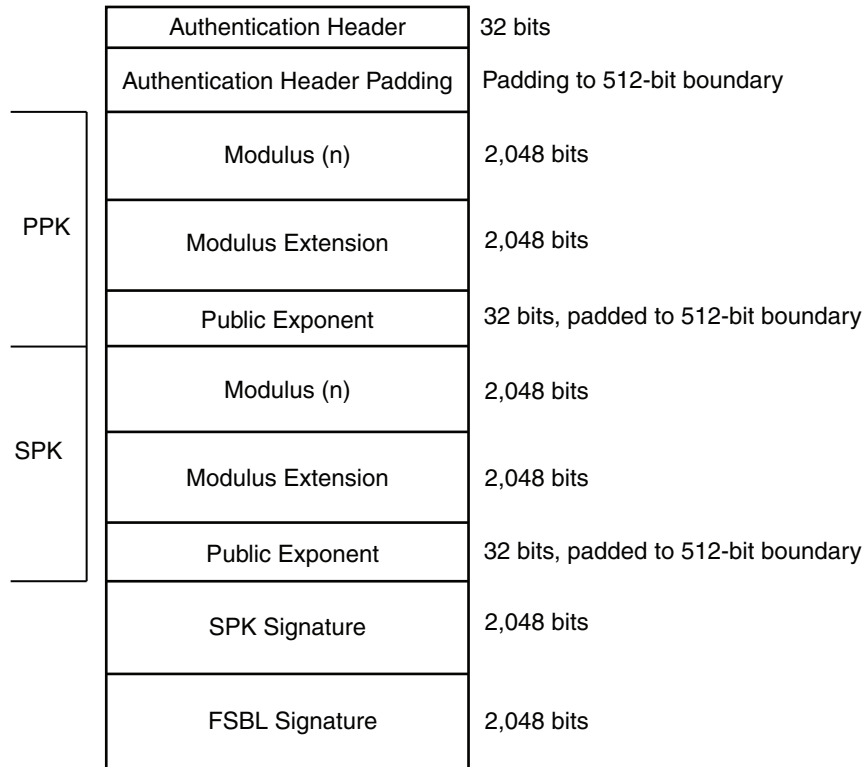

UG585_c33_04_022513

Figure 32-4: RSA Authentication Certificate Format

Note: The FSBL signature includes the FSBL image and the boot image header.

32.2.4 eFUSE Settings

PL eFUSE Settings

The secure boot features can also be controlled via three PL eFuse bits that are described in [Table 32-2](#).

Table 32-2: PL eFuse Settings Summary

| eFUSE Parameters | Description |
|--|--|
| XSK_EFUSEPL_FORCE_USE_AES_ONLY (eFUSE Control Register (FUSE_CNTL), Bit Position 8.) | eFuse Secure Boot. The SoC device must boot securely and use the eFuse key as the AES key source. Non-secure boot of the device is not allowed. If the boot image header does not match this setting, a security lockdown occurs. |

Table 32-2: PL eFuse Settings Summary (Cont'd)

| eFUSE Parameters | Description |
|---|--|
| XSK_EFUSEPL_BBRAM_KEY_DISABLE (FUSE_CNTL[10]) | BBRAM Key Disable. If the SoC device is booted in secure mode, then the eFuse key must be selected. Non-secure boot of the device is allowed. If the boot image header does not match this setting, a security lockdown occurs. |
| XSK_EFUSEPL_DISABLE_JTAG_CHAIN (FUSE_CNTL[9]) | JTAG Chain Disable. The Arm DAP and PL TAP are permanently disabled. Any attempt to activate the Arm DAP or the PL TAP controllers causes a security lockdown. Note: This is because of security implications. If devci.ctrl[JTAG_CHAIN_DIS]=0, it would cause a secure lockdown driving a 0 on TDO and devci.ctrl[JTAG_CHAIN_DIS]=1 essentially means PL TAP is also not accessible (no secure lockdown case). |

Additional information on Zynq-7000 user-configurable PL eFUSE parameters can be found in [UG643, OS and Libraries Document Collection](#).

PS and PL eFUSE summary and correlation with Xilinx Documents are explained in AR# 65110.

PS eFUSE Settings

The PS also has an eFuse array. The primary purpose is to store the memory built in self repair information and the RSA public key hash. The PS eFuse also has a number of fuses that can be used to control the security boot flow of the device. (see [Table 32-3](#)).

Table 32-3: PS eFUSE Setting Summary

| eFUSE Parameters | Description |
|----------------------------------|--|
| eFuse Write Protection (2 fuses) | Blow both of these fuses to permanently disable all writes to the PS eFuse array. |
| BootROM 128KB CRC Enable | Enables a full 128 KB CRC on the ROM prior to loading the FSBL. |
| RSA Authentication Enable | Enables RSA authentication for NAND, NOR, SD, or QSPI. |
| DFT JTAG Disable | The Arm DAP and PL TAP are disabled when the device is booted in DFT mode, any attempt to activate the Arm DAP or the PL TAP causes a security lockdown. |
| DFT Mode Disable | The DFT boot mode is permanently disabled. Booting in DFT mode immediately triggers a security lockdown. |
| RSA PPK Hash (310 fuses) | SHA-256 signature for the RSA primary public key, including extra ECC bits. The ROM reads the PPK hash and checks the ECC hamming code. If there are any 1 bit errors they are automatically corrected and then the corrected value is subsequently used for the rest of the secure boot flow. |



IMPORTANT: *The Zynq-7000 SoC Design for Test (DFT) mode is a Xilinx internal test feature and represents a potential threat to design security as it bypasses the BootROM code. When enabled, the internal memory and configuration are completely cleared, and the device is placed in an unsecure mode, disabling all security features. This is a valuable feature for device test and for debugging problems. While Zynq-7000 SoCs have been designed to ensure these test features do not pose vulnerability, the user can permanently disable them. When debug capabilities are no longer needed*

and device security is paramount, the user can blow redundant eFUSES to permanently disable the device's test capabilities.



CAUTION! If any of the eFuse bits identified in [Table 32-4](#) are programmed to 1, return material authorization (RMA) returns cannot be accepted:

Table 32-4: List of eFuses that prevent the RMA Returns

| PL eFUSE |
|--------------------------------|
| XSK_EFUSEPL_FORCE_USE_AES_ONLY |
| XSK_EFUSEPL_DISABLE_JTAG_CHAIN |
| PS eFUSE |
| DFT JTAG disable |
| DFT Mode disable |

Refer to the *Secure Boot of Zynq-7000 SoC Application Note* ([XAPP1175](#)) for more information.

See [A.3.3 Additional Zynq-7000 SoC Documents](#) for more information on BBRAM and eFUSE Programming.

32.2.5 RSA Authentication

The BootROM has the ability to authenticate a secure FSBL prior to decryption or a non-secure FSBL prior to execution using RSA public key authentication. This feature is enabled by blowing the RSA Authentication Enable fuse in the PS eFuse array.

When RSA authentication is enabled, the BootROM starts by loading the FSBL into the OCM. Then the Primary Public Key (PPK) is loaded and a SHA-256 signature is calculated. This calculated signature is compared to the PPK Hash value stored in the PS eFuse. If the PPK signature matches the PPK Hash value, then the boot continues. The BootROM then loads the Secondary Public Key (SPK) from the boot image and the SPK signature. The SPK is authenticated using the PPK. Failure to authenticate the PPK or SPK triggers a fallback mode by the BootROM. If a new FSBL is not found, the device enters a secure lockdown.

Once the SPK has been authenticated, the BootROM calculates the SHA-256 hash value for the FSBL stored in OCM. The FSBL is authenticated using the SPK. If the authentication passes, a secure FSBL is then decrypted using the AES or a non-secure FSBL will start execution.

32.2.6 Boot Image and Bitstream Encryption

Boot images are assembled and encrypted using software provided by Xilinx, bootgen. A FSBL and any additional PS images or PL bitstreams along with the encryption key and authentication signature must be supplied to bootgen. The correct headers are generated automatically when bootgen builds the boot image.

32.2.7 Boot Image and Bitstream Decryption and Authentication

For PS image and PL bitstream decryption, Xilinx uses the advanced encryption standard (AES) in cipher block chaining (CBC) mode with a 256-bit key. PS images and PL bitstreams are authenticated with a keyed-hashed message authentication code (HMAC) using the SHA-256 hash algorithm. When the BootROM detects that the FSBL image is encrypted, it enables the decryption and authentication engines within the PL. Both are enabled or disabled in tandem and cannot be separated.

Subsequent PS images do not have to be encrypted. Once an encrypted FSBL has been loaded, it is “trusted” and can then load a non-encrypted second stage boot loader or application directly to OCM. Loading of non-encrypted PS images after a secure boot is not recommended and should only be done after fully evaluating the system-level security.

32.2.8 HMAC Signature

HMAC authentication is performed whenever the AES is used. When creating an encrypted boot image, the HMAC key must be provided to the bootgen software. The HMAC key and signature are then encrypted with the boot file. Unlike the AES key, the HMAC key and signature are part of the encrypted image. During the on-chip decryption process, the HMAC signature is extracted from the image and used by the authentication algorithm. No on-chip storage for the HMAC key is required.

32.2.9 AES Key Management

The AES encryption key is stored on-chip within the PL. It can be loaded into either volatile battery-backed RAM (BBRAM) or in non-volatile eFuse storage. The keys are loaded into the PL via the JTAG interface. (See [UG470](#), *7 Series FPGAs Configuration User Guide* for more information.)

32.3 Secure Boot Features

32.3.1 Non-Secure Boot State

The non-secure state is entered when the BootROM detects that the FSBL is not encrypted. In this state the AES decryption and HMAC authentication engines are disabled and locked requiring a power-on reset (POR) to re-enable. RSA authentication is still available in non-secure boots. All subsequent PS images, PL configuration bitstreams, and PL partial re-configuration bitstreams must be non-encrypted.

There is no mechanism to move from the non-secure state to the secure state, aside from power-on reset. Any attempt to load encrypted data after non-encrypted data results in a security violation and security lockdown.

32.3.2 Secure Boot State

The Zynq-7000 SoC always powers up in the secure state, only switching to the non-secure state when the BootROM detects that the FSBL is not encrypted. In the secure state the encrypted FSBL is loaded into the PS. The first configuration bitstream loaded into the PL must also be encrypted.

Since the encrypted FSBL loaded in a secure boot is “trusted”, it is possible to load additional non-encrypted PS images. PL partial re-configuration bitstreams can be loaded via the PCAP or ICAP interfaces as encrypted or non-encrypted. Subsequent PS images or PL bitstreams must use the same key source as the FSBL, key switching is not allowed. Loading of non-encrypted images or bitstreams after a secure boot is not recommended.

32.3.3 Security Lockdown

The PS's device configuration interface contains a security policy block that is used to monitor the system security. When conflicting status is detected either from the PS or the PL that could indicate inconsistent system configuration or tampering, a security lockdown is triggered. In a security lockdown the on-chip RAM is cleared along with all the system caches. The PL is reset and the PS enters a lockdown mode that can only be cleared by issuing a power-on reset. The following conditions cause a security lockdown:

- Non-secure boot specified in the boot image header and secure boot only eFuse is set
- Enabling the JTAG chain or the Arm DAP with the JTAG chain disable eFuse set
- SEU error tracking has been enabled in the PS and the PL reports an SEU error
- A discrepancy in the redundant AES enable logic
- Software sets the FORCE_RST bit of the Device Configuration Control register

32.3.4 Boot Partition Search

The BootROM supports the capability to fall-back and reload a different FSBL if there is a problem with the initial FSBL. In a secure boot, this feature is only supported if the RSA authentication fails, regardless of the encryption status of the FSBL. The new FSBL being loaded must also be signed. If the decryption or HMAC authentication of the FSBL fails, then the device enters secure lockdown. See section [6.3.10 BootROM Header Search](#) for more information.

32.3.5 JTAG and Debug Considerations

Whenever the BootROM is running, the PS DAP and the PL TAP controllers are disabled, eliminating any JTAG access to the SoC device.

In non-secure boot modes JTAG access is restored once the BootROM has completed execution.

In secure boot modes JTAG access can be restored by the FSBL or subsequent PS images as these applications are considered *trusted*. Access to the DAP enable registers can be locked out using the Device Configuration Interface LOCK register.

The PS DAP and PL TAP controllers can be permanently disabled using the JTAG CHAIN DISABLE eFuse. The JTAG access to the PL can also be disabled by setting the DISABLE_JTAG configuration option when creating the PL bitstream. (see [UG628, Command Line Tools User Guide](#) for more information.

32.3.6 Readback

Whenever an encrypted bitstream is loaded into the PL, readback of the internal configuration memory cannot be performed by any of the external interfaces, including JTAG. The only readback access to the configuration memory after an encrypted bitstream load is via PCAP or ICAP. The PCAP and ICAP interfaces are *trusted* channels since access to these interfaces are from an authenticated PS image or an authenticated PL bitstream.

32.3.7 Secure Boot Modes of Operation

Zynq RSA authentication and AES encryption features can be used in a number of combinations to deliver a flexible secure boot solution. [Table 32-5](#) through [Table 32-7](#) show the possible authentication and encryption options available for a Zynq secure boot. The following three points must be taken into consideration when using secure boot:

1. The FSBL must be encrypted if any other PS images or PL bitstreams are required to be encrypted.
2. The BootROM only provides authentication for the FSBL. If any other PS images or PL bitstreams require authentication, the RSA algorithm must be provided as user software.
3. In the secure boot scenario, with the AES key stored in eFUSE, the SRST causes secure lockdown.

Table 32-5: RSA Authentication Options in Non-secure Mode

| | BootROM RSA | User SW RSA | AES / HMAC |
|--------------|-------------|-------------|------------|
| FSBL | Yes | No | No |
| PL Bitstream | No | User Option | No |
| u-Boot | No | User Option | No |
| Linux | No | User Option | No |
| Applications | No | User Option | No |

Table 32-6: Secure Boot Options without RSA Authentication Enabled

| | BootROM RSA | User SW RSA | AES / HMAC |
|--------------|-------------|-------------|-------------|
| FSBL | No | No | Yes |
| PL Bitstream | No | User Option | User Option |
| u-Boot | No | User Option | User Option |
| Linux | No | User Option | User Option |
| Applications | No | User Option | User Option |

Table 32-7: Secure Boot Options with RSA Authentication Enabled

| | BootROM RSA | User SW RSA | AES / HMAC |
|--------------|-------------|-------------|-------------|
| FSBL | Yes | No | Yes |
| PL Bitstream | No | User Option | User Option |
| u-Boot | No | User Option | User Option |
| Linux | No | User Option | User Option |
| Applications | No | User Option | User Option |

Note: The AES engine requires secure mode. In non-secure boot mode, the AES engine cannot be used to load an encrypted bitstream. If a non-encrypted bitstream is loaded in secure mode, the AES engine is turned off. Therefore, when a non-encrypted bitstream is loaded, an encrypted application will not work.

Secure Fallback Flow with eFUSE

In the secure boot scenario, with the AES key stored in eFUSE, the Fallback scenario is handled by FSBL without going through a soft reset and is different than the other flows (see the Secure Fallback Flow with eFUSE section in [UG821, Zynq-7000 SoC Software Developers Guide](#) for more information).

In this scenario the Multiboot must be handled by the user without going through a soft reset (the SRST causes secure lockdown). The only reset that can be used to successfully re-boot the system is PS_POR_B. You need to configure the Watchdog timers for Interrupt and not SRST. You can route the Watchdog Interrupt to perform the POR through a GPIO.

32.4 Programming Considerations

Although most of the secure boot process is handled by the BootROM, it is possible to decrypt PS images or PL bitstreams after the initial boot. To decrypt secure images the PL must be powered on. The PL is powered on and ready to accept new encrypted data if the PCFG_INIT bit of the Device Configuration Interface (DevC) Status register is set.

To send encrypted data to the PL for decryption, the PCAP_MODE and PCAP_PR bits of the DevC Control register must be set to 1. Because the AES engine decrypts data one byte at a time, the QUARTER_PCAP_RATE_EN bit on the DevC Control register must also be set to 1.

To disable the AES and HMAC engines, the three PCFG_AES_EN bits of the DevC Control register must be set to 0. All three bits must be set with the same register write or a security violation occurs, resulting in a security lockdown of the device. Once the AES and HMAC engines have been disabled, they cannot be enabled again without a power-on-reset.

Additional Resources

A.1 Xilinx Resources

Product Support and Documentation

- For support resources such as Answers, Documentation, Downloads, and Forums, see the [Xilinx Support website](#).
- For continual updates, add the Answer Record to your [myAlerts](#).

Device User Guides

<http://www.xilinx.com/support/index.htm>

Zynq-7000 SoC Product Page

<http://www.xilinx.com/products/silicon-devices/soc/zynq-7000/index.htm>

Xilinx Design Tools: Release Notes, Installation, and Licensing

http://www.xilinx.com/support/index.html/content/xilinx/en/supportNav/design_tools.html

Xilinx Forums and Wiki Links

- <http://forums.xilinx.com>
- <http://wiki.xilinx.com>
- <http://wiki.xilinx.com/zynq-linux>
- <http://wiki.xilinx.com/zynq-uboot>

Xilinx git Websites

<https://github.com/xilinx>

A.2 Solution Centers

See the [Xilinx Solution Centers](#) for support on devices, software tools, and intellectual property at all stages of the design cycle. Topics include design assistance, advisories, and troubleshooting tips.

A.3 References

A.3.1 Zynq-7000 SoC Documents

Refer to the following Zynq-7000 SoC documents for further reference:

- DS190, *Zynq-7000 SoC Product Overview*
- DS187, *Zynq-7000 SoC (7z007s, 7z012s, 7z014s, 7z010, 7z015, and 7z020): AC and DC Switching Characteristics Data Sheet*
- DS191, *Zynq-7000 SoC (7z030, 7z045, and 7z100): AC and DC Switching Characteristics Data Sheet*
- UG865, *Zynq-7000 SoC Packaging and Pinout Specifications*
- UG821, *Zynq-7000 SoC Software Developers Guide*
- UG933, *Zynq-7000 SoC PCB Design and Pin Planning Guide*
- XAPP1079, *Simple AMP: Bare-Metal System Running on Both Cortex-A9 Processors*
- XAPP1175, *Secure Boot of Zynq-7000 SoC Application Note*

These user guides and additional relevant information can be found on the Xilinx Zynq-7000 SoC product page:

http://www.xilinx.com/support/index.html/content/xilinx/en/supportNav/silicon_devices/soc/zynq-7000.html

A.3.2 PL Documents – Device and Boards

To learn more about the PL resources, refer to the following 7 Series FPGA User Guides:

- DS821, *Xilinx LogiCORE IP 7 Series FPGAs Integrated Block for PCI Express Product Specification*
- UG471, *Xilinx 7 Series FPGAs SelectIO Resources User Guide*
- UG472, *Xilinx 7 Series FPGAs Clocking Resources User Guide*
- UG473, *Xilinx 7 Series FPGAs Memory Resources User Guide*
- UG474, *Xilinx 7 Series FPGAs Configurable Logic Block User Guide*
- UG476, *Xilinx 7 Series FPGAs GTX Transceiver User Guide*
- PG054, *7 Series FPGAs Integrated Block for PCI Express LogiCORE IP Product Guide*
- UG479, *Xilinx 7 Series FPGAs DSP48E1 User Guide*

- UG480, *Xilinx 7 Series FPGAs XADC User Guide*
- UG483, *Xilinx 7-Series FPGAs PCB and Pin Planning Guide*

These user guides and additional relevant information can be found on the Xilinx 7 Series product page:

http://www.xilinx.com/support/index.html/content/xilinx/en/supportNav/silicon_devices/fpga/n7-series.html

A.3.3 Additional Zynq-7000 SoC Documents

- [UG761](#), *AXI Reference Guide*
- UG761, AXI Reference Guide <existing>
- UG1046, UltraFast Embedded Design Methodology Guide

A.3.4 Software Programming Documents

- [UG821](#), *Zynq-7000 SoC Software Developers Guide*
- [UG873](#), *Zynq-7000 SoC: Concepts, Tools, and Techniques (CTT)*
- UG908, Vivado Design Suite Programming and Debugging User Guide
- UG643, *OS and Libraries Document Collection*
- XAPP1175, *Secure Boot of Zynq-7000 SoC*
- XAPP1223, *Changing the Cryptographic Key in Zynq-7000 SoC*

The source drivers for stand alone and FSBL are provided as part of the Xilinx IDE Design Suite Embedded Edition. The Linux drivers are provided via the Xilinx Open Source Wiki at:

<http://wiki.xilinx.com>

Xilinx Alliance Program partners provide system software solutions for IP, middleware, operation systems, etc. For the latest information refer to the Zynq-7000 landing page at:

<http://www.xilinx.com/products/silicon-devices/soc/zynq-7000>

A.3.5 git Information

- <http://git-scm.com>
- <http://git-scm.com/documentation>
- <http://git-scm.com/download>

A.3.6 Design Tool Resources

Xilinx Vivado Design Suite

http://www.xilinx.com/support/index.html/content/xilinx/en/supportNav/design_tools.html

Xilinx ISE Design Suite

http://www.xilinx.com/support/index.html/content/xilinx/en/supportNav/design_tools/ise_design_suite.html

Xilinx Embedded Development Kit (EDK)

http://www.xilinx.com/support/index.html/content/xilinx/en/supportNav/design_tools/embedded_development_kit_edk.html

ChipScope Pro Documentation

http://www.xilinx.com/support/index.html/content/xilinx/en/supportNav/design_tools/chipscope_pro.html

A.3.7 Xilinx Problem Solvers

<http://www.xilinx.com/support/troubleshoot.htm>

A.3.8 Third-Party IP and Standards Documents

To learn about functional details related to vendor IP cores contained in Zynq-7000 devices or related international interface standards, refer the following documents:

Note: Arm documents can be found at: <http://infocenter.arm.com/help/index.jsp>

- *Arm AMBA Level 2 Cache Controller (L2C-310) TRM* (also called PL310)
- *Arm AMBA Specification Revision 2.0, 1999* (IHI 0011A)
- *Arm Architecture Reference Manual (ARMv7-A)* (DDI0406C)
- *Arm Cortex-A Series Programmer's Guide*
- *Arm Cortex-A9 Technical Reference Manual, Revision r3p0*
- *Arm Cortex-A9 MPCore Technical Reference Manual, Revision r3p0* (DDI0407F) – includes descriptions for accelerator coherency port (ACP), CPU private timers and watchdog timers (AWDT), event bus, general interrupt controller (GIC), and snoop control unit (SCU)
- *Arm Cortex-A9 NEON Media Processing Engine Technical Reference Manual, Revision r3p0*
- *Arm Cortex-A9 Floating-Point Unit Technical Reference Manual, Revision r3p0*
- *Arm CoreSight v1.0 Architecture Specification* – includes descriptions for ATB Bus, and Authentication

- *Arm CoreSight Program Flow Trace Architecture Specification*
- *Arm Debug Interface v5.1 Architecture Specification*
- *Arm Debug Interface v5.1 Architecture Specification Supplement*
- *Arm CoreSight Components TRM* – includes descriptions for embedded cross trigger (ECT), embedded trace buffer (ETB), instrumentation trace macrocell (ITM), debug access port (DAP), and trace port interface unit (TPIU)
- *Arm CoreSight PTM-A9 TRM*
- *Arm CoreSight Trace Memory Controller Technical Reference Manual*
- *Arm Generic Interrupt Controller v1.0 Architecture Specification (IHI 0048B)*
- *Arm Generic Interrupt Controller PL390 Technical Reference Manual (DDI0416B)*
- *Arm PrimeCell DMA Controller (PL330) Technical Reference Manual*
- *Arm Application Note 239: Example programs for CoreLink DMA Controller DMA-330*
- *Arm PrimeCell Static Memory Controller (PL350 series) Technical Reference Manual, Revision r2p1, 12 October 2007 (Arm DDI 0380G)*
- *BOSCH, CAN Specification Version 2.0 PART A and PART B, 1991*
- *Cadence, Watchdog Timer (SWDT) Specification*
- *IEEE 802.3-2008 - IEEE Standard for Information technology-Specific requirements - Part 3: Carrier Sense Multiple Access with Collision Detection (CSMA/CD) Access Method and Physical Layer Specifications, 2008*
- *Universal Serial Bus (USB) Specification, Revision 2.0*
- *UTMI+ Low Pin Interface (ULPI) Specification, Revision 1.1*
- *Enhanced Host Controller Interface (EHCI) Specification for USB, Revision 1.0*
- *SD Association, Part A2 SD Host Controller Standard Specification Ver2.00 Final 070130*
- *SD Association, Part E1 SDIO Specification Ver2.00 Final 070130*
- *SD Group, Part 1 Physical Layer Specification Ver2.00 Final 060509*
- *Cadence Inter Integrated Circuit (I2C) Data Sheet*
- *Micron Serial NOR Flash Memory 1Gb, 1.8V Multiple I/O Serial Flash Memory Features Data Sheet Revision D*

Please Read: Important Legal Notices

The information disclosed to you hereunder (the "Materials") is provided solely for the selection and use of Xilinx products. To the maximum extent permitted by applicable law: (1) Materials are made available "AS IS" and with all faults, Xilinx hereby DISCLAIMS ALL WARRANTIES AND CONDITIONS, EXPRESS, IMPLIED, OR STATUTORY, INCLUDING BUT NOT LIMITED TO WARRANTIES OF MERCHANTABILITY, NON-INFRINGEMENT, OR FITNESS FOR ANY PARTICULAR PURPOSE; and (2) Xilinx shall not be liable (whether in contract or tort, including negligence, or under any other theory of liability) for any loss or damage of any kind or nature related to, arising under, or in connection with, the Materials (including your use of the Materials), including for any direct, indirect, special, incidental, or consequential loss or damage (including loss of data, profits, goodwill, or any type of loss or damage suffered as a result of any action brought by a third party) even if such damage or loss was reasonably foreseeable or Xilinx had been advised of the possibility of the same. Xilinx assumes no obligation to correct any errors contained in the Materials or to notify you of updates to the Materials or to product specifications. You may not reproduce, modify, distribute, or publicly display the Materials without prior written consent. Certain products are subject to the terms and conditions of Xilinx's limited warranty, please refer to Xilinx's Terms of Sale which can be viewed at <https://www.xilinx.com/legal.htm#tos>; IP cores may be subject to

warranty and support terms contained in a license issued to you by Xilinx. Xilinx products are not designed or intended to be fail-safe or for use in any application requiring fail-safe performance; you assume sole risk and liability for use of Xilinx products in such critical applications, please refer to Xilinx's Terms of Sale which can be viewed at <https://www.xilinx.com/legal.htm#tos>.

AUTOMOTIVE APPLICATIONS DISCLAIMER

AUTOMOTIVE PRODUCTS (IDENTIFIED AS "XA" IN THE PART NUMBER) ARE NOT WARRANTED FOR USE IN THE DEPLOYMENT OF AIRBAGS OR FOR USE IN APPLICATIONS THAT AFFECT CONTROL OF A VEHICLE ("SAFETY APPLICATION") UNLESS THERE IS A SAFETY CONCEPT OR REDUNDANCY FEATURE CONSISTENT WITH THE ISO 26262 AUTOMOTIVE SAFETY STANDARD ("SAFETY DESIGN"). CUSTOMER SHALL, PRIOR TO USING OR DISTRIBUTING ANY SYSTEMS THAT INCORPORATE PRODUCTS, THOROUGHLY TEST SUCH SYSTEMS FOR SAFETY PURPOSES. USE OF PRODUCTS IN A SAFETY APPLICATION WITHOUT A SAFETY DESIGN IS FULLY AT THE RISK OF CUSTOMER, SUBJECT ONLY TO APPLICABLE LAWS AND REGULATIONS GOVERNING LIMITATIONS ON PRODUCT LIABILITY.

© Copyright 2012-2021 Xilinx, Inc. Xilinx, the Xilinx logo, Alveo, Artix, Kintex, Spartan, Versal, Virtex, Vivado, Zynq, and other designated brands included herein are trademarks of Xilinx in the United States and other countries. AMBA, AMBA Designer, Arm, ARM1176JZ-S, CoreSight, Cortex, PrimeCell, Mali, and MPCore are trademarks of Arm Limited in the EU and other countries. PCI, PCIe, and PCI Express are trademarks of PCI-SIG and used under license. All other trademarks are the property of their respective owners.

Register Details

B.1 Overview

This appendix provides details of all the memory-mapped registers in the Zynq®-7000 SoC.

Throughout this manual, the names of registers and register bit fields used match those given in the hardware. They are called the hardware names. C header files are delivered with this product which define register and bit field names for easy use in software code. In some cases, the software names are different from the hardware names. This appendix includes software names where they differ from hardware names:

- **Software Module Name:** This is included in the module introduction section and is named *Software Name*.
- **Software Register Name:** This is included in the detailed register description and is also named *Software Name*.
- **Software Bit field Name:** These are included in the register bit field tables in the *Field Name* column. These names follow the hardware field name and are contained in parentheses.

Note: If a software name does not exist in the C header files or if it exists but is the same as the hardware name, it is not included in this appendix and the above fields are not present.

The software register name will be:

`<software module name>_<software register name>_<optional suffix>`. One common suffix used for register names is "OFFSET", which would give the OFFSET address of that register from the base address for the module.

The software bit field name will be:

`<software module name>_<software register name>_<software bit field name>_<optional suffix>`. One common suffix used for bit field names is "MASK", which would be useful when extracting the bit field of interest from the full register.

B.2 Acronyms

The following acronyms are used for many of the registers.

| Access Type | Description |
|-------------|---|
| clonrd | Readable, clears value on read |
| clonwr | Readable, clears value on write |
| nsnsro | During non-secure access, if thread is non-secure, it is read only |
| nsnsrw | During non-secure access, if thread is non-secure, it is read write |
| nsnswo | During non-secure access, if thread is non-secure, it is write only |
| nssraz | During non-secure access, if thread is secure, it is read as zero |
| raz | Read as zero |
| ro | Read-only |
| rud | Read undefined |
| rw | Normal read/write |
| rwso | Read/write, set only |
| sro | During secure access, it is read only |
| srw | During secure access, it is read write |
| swo | During secure access, it is write only |
| waz | Write as zero |
| wo | Write-only |
| wtc | Readable, write a one to clear |
| z | Access (read or write) as zero |

B.3 Module Summary

| Module Name | Module Type | Base Address | Description |
|--------------------|------------------------------|--------------|---|
| axi_hp0 | axi_hp | 0xF8008000 | AXI_HP Interface (AFI), Interface 0 |
| axi_hp1 | axi_hp | 0xF8009000 | AXI_HP Interface (AFI), Interface 1 |
| axi_hp2 | axi_hp | 0xF800A000 | AXI_HP Interface (AFI), Interface 2 |
| axi_hp3 | axi_hp | 0xF800B000 | AXI_HP Interface (AFI), Interface 3 |
| can0 | can | 0xE0008000 | Controller Area Network |
| can1 | can | 0xE0009000 | Controller Area Network |
| ddrc | ddrc | 0xF8006000 | DDR memory controller |
| debug_cpu_cti0 | cti | 0xF8898000 | Cross Trigger Interface, CPU 0 |
| debug_cpu_cti1 | cti | 0xF8899000 | Cross Trigger Interface, CPU 1 |
| debug_cpu_pmu0 | cortexa9_pmu | 0xF8891000 | Cortex A9 Performance Monitoring Unit, CPU 0 |
| debug_cpu_pmu1 | cortexa9_pmu | 0xF8893000 | Cortex A9 Performance Monitoring Unit, CPU 1 |
| debug_cpu_ptm0 | ptm | 0xF889C000 | CoreSight PTM-A9, CPU 0 |
| debug_cpu_ptm1 | ptm | 0xF889D000 | CoreSight PTM-A9, CPU 1 |
| debug_cti_etb_tpiu | cti | 0xF8802000 | Cross Trigger Interface, ETB and TPIU |
| debug_cti_ftm | cti | 0xF8809000 | Cross Trigger Interface, FTM |
| debug_dap_rom | dap | 0xF8800000 | Debug Access Port ROM Table |
| debug_etb | etb | 0xF8801000 | Embedded Trace Buffer |
| debug_ftm | ftm | 0xF880B000 | Fabric Trace Macrocell |
| debug_funnel | funnel | 0xF8804000 | CoreSight Trace Funnel |
| debug_itm | itm | 0xF8805000 | Instrumentation Trace Macrocell |
| debug_tpiu | tpiu | 0xF8803000 | Trace Port Interface Unit |
| devcfg | devcfg | 0xF8007000 | Device configuration Interface |
| dmac0_ns | dmac | 0xF8004000 | Direct Memory Access Controller, PL330, Non-Secure Mode |
| dmac0_s | dmac | 0xF8003000 | Direct Memory Access Controller, PL330, Secure Mode |
| gem0 | GEM | 0xE000B000 | Gigabit Ethernet Controller |
| gem1 | GEM | 0xE000C000 | Gigabit Ethernet Controller |
| gpio | gpio | 0xE000A000 | General Purpose Input / Output |

| Module Name | Module Type | Base Address | Description |
|-----------------|---|--------------|---|
| gpv_qos301_cpu | qos301 | 0xF8946000 | AMBA Network Interconnect Advanced Quality of Service (QoS-301), CPU-to-DDR |
| gpv_qos301_dmac | qos301 | 0xF8947000 | AMBA Network Interconnect Advanced Quality of Service (QoS-301), DMAC |
| gpv_qos301_iou | qos301 | 0xF8948000 | AMBA Network Interconnect Advanced Quality of Service (QoS-301), IOU |
| gpv_trustzone | nic301_addr_region_ctrl_registers | 0xF8900000 | AMBA NIC301 TrustZone. |
| i2c0 | IIC | 0xE0004000 | Inter Integrated Circuit (I2C) |
| i2c1 | IIC | 0xE0005000 | Inter Integrated Circuit (I2C) |
| l2cache | L2Cpl310 | 0xF8F02000 | L2 cache PL310 |
| mpcore | mpcore | 0xF8F00000 | Mpcore - SCU, Interrupt controller, Counters and Timers |
| ocm | ocm | 0xF800C000 | On-Chip Memory Registers |
| qspi | qsqi | 0xE000D000 | LQSPI module Registers |
| sd0 | sdio | 0xE0100000 | SD2.0/ SDIO2.0/ MMC3.31 AHB Host ControllerRegisters |
| sd1 | sdio | 0xE0101000 | SD2.0/ SDIO2.0/ MMC3.31 AHB Host ControllerRegisters |
| slcr | slcr | 0xF8000000 | System Level Control Registers |
| smcc | pl353 | 0xE000E000 | Shared memory controller |
| spi0 | SPI | 0xE0006000 | Serial Peripheral Interface |
| spi1 | SPI | 0xE0007000 | Serial Peripheral Interface |
| swdt | swdt | 0xF8005000 | System Watchdog Timer Registers |
| ttc0 | ttc | 0xF8001000 | Triple Timer Counter |
| ttc1 | ttc | 0xF8002000 | Triple Timer Counter |
| uart0 | UART | 0xE0000000 | Universal Asynchronous Receiver Transmitter |
| uart1 | UART | 0xE0001000 | Universal Asynchronous Receiver Transmitter |
| usb0 | usb | 0xE0002000 | USB controller registers |
| usb1 | usb | 0xE0003000 | USB controller registers |

50 modules, 2040 registers.

B.4 AXI_HP Interface (AFI) (axi_hp)

| | |
|--------------|--|
| Module Name | AXI_HP Interface (AFI) (axi_hp) |
| Base Address | 0xF8008000 axi_hp0 0xF8009000 axi_hp1 0xF800A000 axi_hp2 0xF800B000 axi_hp3 |
| Description | AXI_HP Interface (AFI) |
| Vendor Info | Xilinx S_AXI_HP |

Register Summary

| Register Name | Address | Width | Type | Reset Value | Description |
|--|------------|-------|-------|-------------|-----------------------------------|
| AFI_RDCHAN_CTRL | 0x00000000 | 32 | mixed | 0x00000000 | Read Channel Control Register |
| AFI_RDCHAN_ISSUING CAP | 0x00000004 | 32 | mixed | 0x00000007 | Read Issuing Capability Register |
| AFI_RDQOS | 0x00000008 | 32 | mixed | 0x00000000 | QOS Read Channel Register |
| AFI_RDDATAFIFO_LEVEL | 0x0000000C | 32 | mixed | 0x00000000 | Read Data FIFO Level Register |
| AFI_RDDEBUG | 0x00000010 | 32 | mixed | 0x00000000 | Read Channel Debug Register |
| AFI_WRCHAN_CTRL | 0x00000014 | 32 | mixed | 0x00000F00 | Write Channel Control Register |
| AFI_WRCHAN_ISSUING CAP | 0x00000018 | 32 | mixed | 0x00000007 | Write Issuing Capability Register |
| AFI_WRQOS | 0x0000001C | 32 | mixed | 0x00000000 | QOS Write Channel Register |
| AFI_WRDATAFIFO_LEVEL | 0x00000020 | 32 | mixed | 0x00000000 | Write Data FIFO Level Register |
| AFI_WRDEBUG | 0x00000024 | 32 | mixed | 0x00000000 | Write Channel Debug Register |

Register ([axi_hp](#)) AFI_RDCHAN_CTRL

| | |
|------------------|--|
| Name | AFI_RDCHAN_CTRL |
| Relative Address | 0x00000000 |
| Absolute Address | axi_hp0: 0xF8008000 axi_hp1: 0xF8009000 axi_hp2: 0xF800A000 axi_hp3: 0xF800B000 |
| Width | 32 bits |
| Access Type | mixed |
| Reset Value | 0x00000000 |
| Description | Read Channel Control Register |

Register AFI_RDCHAN_CTRL Details

Control fields for Read Channel operation.

The associated "FPGA_RST_CTRL.FPGA_AXDSN_RST" register field must be written with "0" before accessing this register

| Field Name | Bits | Type | Reset Value | Description |
|-----------------|------|------|-------------|--|
| reserved | 31:4 | raz | 0x0 | Return 0 when read |
| QosHeadOfCmdQEn | 3 | rw | 0x0 | When set, allows the priority of a transaction at the head of the RdCmdQ to be promoted if higher priority transactions are backed up behind it. The entire RdCmdQ will therefore be promoted when the fabric RdQos signal is promoted. When disabled, only the new read commands issued will receive the promotion. |
| FabricOutCmdEn | 2 | rw | 0x0 | Enable control of outstanding read commands from the fabric 0: The maximum number of outstanding read commands is always taken from APB register field, rdIssueCap0 1: The maximum outstanding number of read commands is selected from the fabric input, axds_rdisuecap1_en, as follows: IF (axds_rdisuecap1_en) Max Outstanding Read Commands = rdIssueCap1 ELSE Max Outstanding Read Commands = rdIssueCap0 |
| FabricQosEn | 1 | rw | 0x0 | Enable control of qos from the fabric 0: The qos bits are derived from APB register, AFI_RDQOS.staticQos 1: The qos bits are dynamically driven from the fabric input, axds_arqos[3:0] |
| 32BitEn | 0 | rw | 0x0 | Configures the Read Channel as a 32-bit interface. 1: 32-bit enabled 0: 64-bit enabled |

Register ([axi_hp](#)) AFI_RDCHAN_ISSUINGCAP

Name AFI_RDCHAN_ISSUINGCAP
Relative Address 0x00000004

Absolute Address axi_hp0: 0xF8008004
 axi_hp1: 0xF8009004
 axi_hp2: 0xF800A004
 axi_hp3: 0xF800B004

Width 32 bits

Access Type mixed

Reset Value 0x00000007

Description Read Issuing Capability Register

Register AFI_RDCHAN_ISSUINGCAP Details

Sets the maximum number of Outstanding Read Commands allowed (Issuing Capability). Refers to the commands that can be outstanding from the AXI_HP to the SAM switch and back. Fields are selected by the 'axds_rdisuecap1_en' input. The associated "FPGA_RST_CTRL.FPGA_AXDSN_RST" register field

must be written with "0" before accessing this register

| Field Name | Bits | Type | Reset Value | Description |
|-------------|------|------|-------------|---|
| reserved | 31:7 | raz | 0x0 | Return 0 when read |
| rdIssueCap1 | 6:4 | rw | 0x0 | Max number of outstanding read commands (Read Issuing Capability) field 1: 3'b000: 1 command 3'b001: 2 commands ' '3'b111: 8 commands |
| reserved | 3 | raz | 0x0 | Return 0 when read |
| rdIssueCap0 | 2:0 | rw | 0x7 | Max number of outstanding read commands (Read Issuing Capability) field 0: 3'b000: 1 command 3'b001: 2 commands ' '3'b111: 8 commands |

Register ([axi_hp](#)) AFI_RDQOS

Name AFI_RDQOS

Relative Address 0x00000008

Absolute Address axi_hp0: 0xF8008008
 axi_hp1: 0xF8009008
 axi_hp2: 0xF800A008
 axi_hp3: 0xF800B008

Width 32 bits

Access Type mixed

Reset Value 0x00000000

Description QOS Read Channel Register

Register AFI_RDQOS Details

Sets the static Qos value to be used for the read channel. If APB register field, 'FabricQosEn' is 0 or ('FabricQosEn' is 1 and 'QosHeadOfCmdQEn' is 1), this static Qos value will be applied to all read commands enqueued into the RdCmdQ. If ('FabricQosEn' is 1 and 'QosHeadOfCmdQEn' is 0), this static Qos field will be ignored. The associated "FPGA_RST_CTRL.FPGA_AXDSN_RST" register field must be written with "0" before accessing this register

| Field Name | Bits | Type | Reset Value | Description |
|------------|------|------|-------------|--|
| reserved | 31:4 | raz | 0x0 | Return 0 when read |
| staticQos | 3:0 | rw | 0x0 | Sets the level of the Qos field to be used for the read channel 4'b0000: Lowest Priority ' '4'b1111: Highest Priority |

Register ([axi_hp](#)) AFI_RDDATAFIFO_LEVEL

| | |
|------------------|--|
| Name | AFI_RDDATAFIFO_LEVEL |
| Relative Address | 0x0000000C |
| Absolute Address | axi_hp0: 0xF800800C axi_hp1: 0xF800900C axi_hp2: 0xF800A00C axi_hp3: 0xF800B00C |
| Width | 32 bits |
| Access Type | mixed |
| Reset Value | 0x00000000 |
| Description | Read Data FIFO Level Register |

Register AFI_RDDATAFIFO_LEVEL Details

Returns the Level of the Read Data FIFO in Qwords. Note that this register should only be read if a valid HP port clock is actively running. If no clock is running the APB access will hang. The associated "FPGA_RST_CTRL.FPGA_AXDSN_RST" register field must be written with "0" before accessing this register

| Field Name | Bits | Type | Reset Value | Description |
|------------|------|------|-------------|---|
| reserved | 31:8 | raz | 0x0 | Return 0 when read |
| FifoLevel | 7:0 | ro | 0x0 | Returns the level measured in Dwords (64-bits) of the Read Data FIFO 8'h00: 0 Entries 8'h01: 1 Entry' '8'h8F: 128 Entries |

Register ([axi_hp](#)) AFI_RDDEBUG

| | |
|------------------|--|
| Name | AFI_RDDEBUG |
| Relative Address | 0x00000010 |
| Absolute Address | axi_hp0: 0xF8008010 axi_hp1: 0xF8009010 axi_hp2: 0xF800A010 axi_hp3: 0xF800B010 |
| Width | 32 bits |
| Access Type | mixed |
| Reset Value | 0x00000000 |
| Description | Read Channel Debug Register |

Register AFI_RDDEBUG Details

Miscellaneous debug fields for the Read channel. Not to be used for functional purposes. The associated "FPGA_RST_CTRL.FPGA_AXDSN_RST" register field

must be written with "0" before accessing this register

| Field Name | Bits | Type | Reset Value | Description |
|--------------------|------|------|-------------|--|
| reserved | 31:5 | raz | 0x0 | Return 0 when read |
| OutRdCmds | 4:1 | ro | 0x0 | Returns the number of read commands in flight between the AXI_HP and the SAM switch 4'h0: 0 4'h1: 1 etc |
| RdDataFifoOverflow | 0 | ro | 0x0 | Bit is set if the RdDataFIFO overflows |

Register ([axi_hp](#)) AFI_WRCHAN_CTRL

| | |
|------------------|--|
| Name | AFI_WRCHAN_CTRL |
| Relative Address | 0x00000014 |
| Absolute Address | axi_hp0: 0xF8008014 axi_hp1: 0xF8009014 axi_hp2: 0xF800A014 axi_hp3: 0xF800B014 |
| Width | 32 bits |
| Access Type | mixed |
| Reset Value | 0x00000F00 |
| Description | Write Channel Control Register |

Register AFI_WRCHAN_CTRL Details

Control fields for Write Channel operation. The associated "FPGA_RST_CTRL.FPGA_AXDSN_RST" register field

must be written with "0" before accessing this register

| Field Name | Bits | Type | Reset Value | Description |
|------------------|-------|------|-------------|--|
| reserved | 31:12 | raz | 0x0 | Return 0 when read |
| WrDataThreshold | 11:8 | rw | 0xF | <p>Sets the threshold at which to send the write command. Note that this is measured in data beats, and is therefore dependent on the '32bitEn' field.</p> <p>4'b0000: Send Write Command When 1 data beat is pushed into the Write Data FIFO</p> <p>4'b0001: Send Write Command When 2 data beats are pushed into the Write Data FIFO</p> <p>'4'b1111: Send Write Command When 16 data beats are pushed into the Write Data FIFO</p> <p>Note: If this field is programmed to be less than the actual burst length of the write command, the 'Wlast' will take priority. For example, if 'WrDataThreshold' is set to 4'b1111 (indicates 16 beats), and a Wlast is received after 8 beats, the write command is sent.</p> |
| reserved | 7:6 | raz | 0x0 | Return 0 when read |
| WrCmdReleaseMode | 5:4 | rw | 0x0 | <p>Mode of Write Command Release.</p> <p>2'b00: Release Wr Command on 'Wlast' enqueue into Write Data FIFO</p> <p>2'b01: Release Wr Command on a particular threshold being reached on the enqueue into Write Data FIFO. The 'WrDataThreshold' field is used to program the actual threshold.</p> <p>2'b10: Reserved</p> <p>2'b11: Reserved</p> |
| QosHeadOfCmdQEn | 3 | rw | 0x0 | <p>When set, allows the priority of a transaction at the head of the WrCmdQ to be promoted if higher priority transactions are backed up behind it. The entire WrCmdQ will therefore be 'promoted' when the fabric 'WrQos' signal is promoted.</p> <p>When disabled, only the new write commands issued will receive the 'promotion'.</p> |

| Field Name | Bits | Type | Reset Value | Description |
|----------------|------|------|-------------|---|
| FabricOutCmdEn | 2 | rw | 0x0 | Enable control of outstanding write commands from the fabric 0: The maximum number of outstanding write commands is always taken from APB register field, 'wrIssueCap0' 1: The maximum outstanding number of write commands is selected from the fabric input, 'axds_wrissuecap1_en', as follows: IF (axds_wrissuecap1_en) Max Outstanding Write Commands = wrIssueCap1 ELSE Max Outstanding Write Commands = wrIssueCap0 |
| FabricQosEn | 1 | rw | 0x0 | Enable control of qos from the fabric 0: The qos bits are derived from APB register, 'AFI_WRQOS.staticQos' 1: The qos bits are dynamically driven from the fabric input, 'axds_awqos[3:0]' |
| 32BitEn | 0 | rw | 0x0 | Configures the Write Channel as a 32-bit interface. 1: 32-bit enabled 0: 64-bit enabled |

Register ([axi_hp](#)) AFI_WRCHAN_ISSUINGCAP

| | |
|------------------|--|
| Name | AFI_WRCHAN_ISSUINGCAP |
| Relative Address | 0x00000018 |
| Absolute Address | axi_hp0: 0xF8008018 axi_hp1: 0xF8009018 axi_hp2: 0xF800A018 axi_hp3: 0xF800B018 |
| Width | 32 bits |
| Access Type | mixed |
| Reset Value | 0x00000007 |
| Description | Write Issuing Capability Register |

Register AFI_WRCHAN_ISSUINGCAP Details

Sets the maximum number of Outstanding Write Commands (Issuing Capability) allowed. Refers to the commands that can be outstanding from the AXI_HP to the SAM switch and back. Fields are selected by the 'axds_wrissuecap1_en' input. The associated "FPGA_RST_CTRL.FPGA_AXDSN_RST" register field

must be written with "0" before accessing this register

| Field Name | Bits | Type | Reset Value | Description |
|-------------|------|------|-------------|--|
| reserved | 31:7 | raz | 0x0 | Return 0 when read |
| wrIssueCap1 | 6:4 | rw | 0x0 | Max number of outstanding write commands (Write Issuing Capability) field 1: 3'b000: 1 command 3'b001: 2 commands ' ' 3'b111: 8 commands |
| reserved | 3 | raz | 0x0 | Return 0 when read |
| wrIssueCap0 | 2:0 | rw | 0x7 | Max number of outstanding write commands (Write Issuing Capability) field 0: 3'b000: 1 command 3'b001: 2 commands ' ' 3'b111: 8 commands |

Register ([axi_hp](#)) AFI_WRQOS

| | |
|------------------|--|
| Name | AFI_WRQOS |
| Relative Address | 0x0000001C |
| Absolute Address | axi_hp0: 0xF800801C axi_hp1: 0xF800901C axi_hp2: 0xF800A01C axi_hp3: 0xF800B01C |
| Width | 32 bits |
| Access Type | mixed |
| Reset Value | 0x00000000 |
| Description | QOS Write Channel Register |

Register AFI_WRQOS Details

Sets the static Qos value to be used for the write channel. If APB register field, 'FabricQosEn' is 0 or ('FabricQosEn' is 1 and 'QosHeadOfCmdQEn' is 1), this static Qos value will be applied to all write commands enqueued into the WrCmdQ. If ('FabricQosEn' is 1 and 'QosHeadOfCmdQEn' is 0), this static Qos field will be ignored. The associated "FPGA_RST_CTRL.FPGA_AXDSN_RST" register field

must be written with "0" before accessing this register

| Field Name | Bits | Type | Reset Value | Description |
|------------|------|------|-------------|--|
| reserved | 31:4 | raz | 0x0 | Return 0 when read |
| staticQos | 3:0 | rw | 0x0 | Sets the level of the Qos field to be used for the write channel 4'b0000: Lowest Priority ' ' 4'b1111: Highest Priority |

Register ([axi_hp](#)) AFI_WRDATAFIFO_LEVEL

| | |
|------------------|--|
| Name | AFI_WRDATAFIFO_LEVEL |
| Relative Address | 0x00000020 |
| Absolute Address | axi_hp0: 0xF8008020 axi_hp1: 0xF8009020 axi_hp2: 0xF800A020 axi_hp3: 0xF800B020 |
| Width | 32 bits |
| Access Type | mixed |
| Reset Value | 0x00000000 |
| Description | Write Data FIFO Level Register |

Register AFI_WRDATAFIFO_LEVEL Details

Returns the Level of the Write Data FIFO in Dwords. Note that this register should only be read if a valid HP port clock is actively running. If no clock is present, the APB access will hang. The associated "FPGA_RST_CTRL.FPGA_AXDSN_RST" register field

must be written with "0" before accessing this register

| Field Name | Bits | Type | Reset Value | Description |
|------------|------|------|-------------|--|
| reserved | 31:8 | raz | 0x0 | Return 0 when read |
| FifoLevel | 7:0 | ro | 0x0 | Returns the level measured in Dwords (64-bits) of the Write Data FIFO 8'h00: 0 Entries 8'h01: 1 Entry ' ' 8'h8F: 128 Entries |

Register ([axi_hp](#)) AFI_WRDEBUG

| | |
|------------------|--|
| Name | AFI_WRDEBUG |
| Relative Address | 0x00000024 |
| Absolute Address | axi_hp0: 0xF8008024 axi_hp1: 0xF8009024 axi_hp2: 0xF800A024 axi_hp3: 0xF800B024 |
| Width | 32 bits |
| Access Type | mixed |
| Reset Value | 0x00000000 |
| Description | Write Channel Debug Register |

Register AFI_WRDEBUG Details

The associated "FPGA_RST_CTRL.FPGA_AXDSN_RST" register field must be written with "0" before accessing this register

| Field Name | Bits | Type | Reset Value | Description |
|--------------------|------|------|-------------|---|
| reserved | 31:5 | raz | 0x0 | Return 0 when read |
| OutWrCmds | 4:1 | ro | 0x0 | Returns the number of write commands in flight between the AXI_HP and the SAM switch 4'h0: 0 4'h1: 1 etc |
| WrDataFifoOverflow | 0 | ro | 0x0 | Bit is set if the WrDataFIFO overflows |

B.5 CAN Controller (can)

| | |
|---------------|------------------------------------|
| Module Name | CAN Controller (can) |
| Software Name | XCANPS |
| Base Address | 0xE0008000 can0 0xE0009000 can1 |
| Description | Controller Area Network |
| Vendor Info | Xilinx CAN |

Register Summary

| Register Name | Address | Width | Type | Reset Value | Description |
|--|------------|-------|-------|-------------|--|
| XCANPS_SRR_OFFSET | 0x00000000 | 32 | rw | 0x00000000 | Software Reset Register |
| XCANPS_MSR_OFFSET | 0x00000004 | 32 | rw | 0x00000000 | Mode Select Register |
| XCANPS_BRPR_OFFSET | 0x00000008 | 32 | rw | 0x00000000 | Baud Rate Prescaler Register |
| XCANPS_BTR_OFFSET | 0x0000000C | 32 | rw | 0x00000000 | Bit Timing Register |
| XCANPS_ECR_OFFSET | 0x00000010 | 32 | ro | 0x00000000 | Error Counter Register |
| XCANPS_ESR_OFFSET | 0x00000014 | 32 | mixed | 0x00000000 | Error Status Register |
| XCANPS_SR_OFFSET | 0x00000018 | 32 | mixed | 0x00000001 | Status Register |
| XCANPS_ISR_OFFSET | 0x0000001C | 32 | mixed | 0x00006000 | Interrupt Status Register |
| XCANPS_IER_OFFSET | 0x00000020 | 32 | rw | 0x00000000 | Interrupt Enable Register |
| XCANPS_ICR_OFFSET | 0x00000024 | 32 | mixed | 0x00000000 | Interrupt Clear Register |
| XCANPS_TCR_OFFSET | 0x00000028 | 32 | mixed | 0x00000000 | Timestamp Control Register |
| XCANPS_WIR_OFFSET | 0x0000002C | 32 | rw | 0x00003F3F | Watermark Interrupt Register |
| XCANPS_TXFIFO_ID_OFFSET | 0x00000030 | 32 | wo | 0x00000000 | transmit message fifo message identifier |
| XCANPS_TXFIFO_DLC_OFFSET | 0x00000034 | 32 | wo | 0x00000000 | transmit message fifo data length code |
| XCANPS_TXFIFO_DW1_OFFSET | 0x00000038 | 32 | wo | 0x00000000 | transmit message fifo data word 1 |
| XCANPS_TXFIFO_DW2_OFFSET | 0x0000003C | 32 | wo | 0x00000000 | transmit message fifo data word 2 |
| XCANPS_TXHPB_ID_OFFSET | 0x00000040 | 32 | wo | 0x00000000 | transmit high priority buffer message identifier |
| XCANPS_TXHPB_DLC_OFFSET | 0x00000044 | 32 | wo | 0x00000000 | transmit high priority buffer data length code |
| XCANPS_TXHPB_DW1_OFFSET | 0x00000048 | 32 | wo | 0x00000000 | transmit high priority buffer data word 1 |
| XCANPS_TXHPB_DW2_OFFSET | 0x0000004C | 32 | wo | 0x00000000 | transmit high priority buffer data word 2 |

| Register Name | Address | Width | Type | Reset Value | Description |
|--|------------|-------|------|-------------|---|
| XCANPS_RXFIFO_ID_OFFSET | 0x00000050 | 32 | ro | x | receive message fifo message identifier |
| XCANPS_RXFIFO_DLC_OFFSET | 0x00000054 | 32 | rw | x | receive message fifo data length code |
| XCANPS_RXFIFO_DW1_OFFSET | 0x00000058 | 32 | rw | x | receive message fifo data word 1 |
| XCANPS_RXFIFO_DW2_OFFSET | 0x0000005C | 32 | rw | x | receive message fifo data word 2 |
| XCANPS_AFR_OFFSET | 0x00000060 | 32 | rw | 0x00000000 | Acceptance Filter Register |
| XCANPS_AFMR1_OFFSET | 0x00000064 | 32 | rw | x | Acceptance Filter Mask Register 1 |
| XCANPS_AFIR1_OFFSET | 0x00000068 | 32 | rw | x | Acceptance Filter ID Register 1 |
| XCANPS_AFMR2_OFFSET | 0x0000006C | 32 | rw | x | Acceptance Filter Mask Register 2 |
| XCANPS_AFIR2_OFFSET | 0x00000070 | 32 | rw | x | Acceptance Filter ID Register 2 |
| XCANPS_AFMR3_OFFSET | 0x00000074 | 32 | rw | x | Acceptance Filter Mask Register 3 |
| XCANPS_AFIR3_OFFSET | 0x00000078 | 32 | rw | x | Acceptance Filter ID Register 3 |
| XCANPS_AFMR4_OFFSET | 0x0000007C | 32 | rw | x | Acceptance Filter Mask Register 4 |
| XCANPS_AFIR4_OFFSET | 0x00000080 | 32 | rw | x | Acceptance Filter ID Register 4 |

Register ([can](#)) XCANPS_SRR_OFFSET

| | |
|------------------|--------------------------------------|
| Name | XCANPS_SRR_OFFSET |
| Software Name | SRR |
| Relative Address | 0x00000000 |
| Absolute Address | can0: 0xE0008000 can1: 0xE0009000 |
| Width | 32 bits |
| Access Type | rw |
| Reset Value | 0x00000000 |
| Description | Software Reset Register |

Register XCANPS_SRR_OFFSET Details

Writing to the Software Reset Register (SRR) places the CAN controller in Configuration mode. Once in Configuration mode, the CAN controller drives recessive on the bus line and does not transmit or receive messages. During power-up, CEN and SRST bits are '0' and CONFIG bit in the Status Register (SR) is '1.' The Transfer Layer Configuration Registers can be changed only when CEN bit in the SRR Register is '0.' If the CEN bit is changed during core operation, it is recommended to reset the core so that operations start afresh.

| Field Name | Bits | Type | Reset Value | Description |
|-----------------------------|------|------|-------------|---|
| reserved | 31:2 | rw | 0x0 | Reserved. |
| XCANPS_SRR_CEN_MASK (CEN) | 1 | rw | 0x0 | Can Enable The Enable bit for the CAN controller. 1: The CAN controller is in Loop Back, Sleep or Normal mode depending on the LBACK and SLEEP bits in the MSR. 0: The CAN controller is in the Configuration mode. If the CEN bit is changed during core operation, it is recommended to reset the core so that operations start afresh. |
| XCANPS_SRR_SRST_MASK (SRST) | 0 | rw | 0x0 | Reset The Software reset bit for the CAN controller. 1: CAN controller is reset. If a 1 is written to this bit, all the CAN controller configuration registers (including the SRR) are reset. Reads to this bit always return a 0. |

Register ([can](#)) XCANPS_MSR_OFFSET

| | |
|------------------|--------------------------------------|
| Name | XCANPS_MSR_OFFSET |
| Software Name | MSR |
| Relative Address | 0x00000004 |
| Absolute Address | can0: 0xE0008004 can1: 0xE0009004 |
| Width | 32 bits |
| Access Type | rw |
| Reset Value | 0x00000000 |
| Description | Mode Select Register |

Register XCANPS_MSR_OFFSET Details

Writing to the Mode Select Register (MSR) enables the CAN controller to enter Snoop, Sleep, Loop Back, or Normal modes. In Normal mode, the CAN controller participates in normal bus communication. If the SLEEP bit is set to '1,' the CAN controller enters Sleep mode. If the LBACK bit is set to '1,' the CAN controller enters Loop Back mode. If the SNOOP mode is set to '1,' the CAN controller enters Snoop mode and does not participate in bus communication but only receives messages.

The LBACK and SLEEP bits should never be set to '1' at the same time. At any given point the CAN controller can be either in Loop Back mode or Sleep mode, but not both simultaneously. If both bits are set, then LBACK Mode takes priority. SNOOP Mode has least priority. In order for core to enter SNOOP mode LBACK and SLEEP modes should be set to '0'.

| Field Name | Bits | Type | Reset Value | Description |
|-------------------------------|------|------|-------------|--|
| reserved | 31:3 | rw | 0x0 | Reserved. |
| XCANPS_MSR_SNOOP_MASK (SNOOP) | 2 | rw | 0x0 | Snoop Mode Select The Snoop Mode Select bit. 1: CAN controller is in Snoop mode. 0: CAN controller is in Normal, Loop Back, Configuration, or Sleep mode. This bit can be written to only when CEN bit in SRR is 0. |
| XCANPS_MSR_LBACK_MASK (LBACK) | 1 | rw | 0x0 | Loop Back Mode Select The Loop Back Mode Select bit. 1: CAN controller is in Loop Back mode. 0: CAN controller is in Normal, Snoop, Configuration, or Sleep mode. This bit can be written to only when CEN bit in SRR is 0. |
| XCANPS_MSR_SLEEP_MASK (SLEEP) | 0 | rw | 0x0 | Sleep Mode Select The Sleep Mode select bit. 1: CAN controller is in Sleep mode. 0: CAN controller is in Normal, Snoop, Configuration or Loop Back mode. This bit is cleared when the CAN controller wakes up from the Sleep mode. |

Register ([can](#)) XCANPS_BRPR_OFFSET

| | |
|------------------|--------------------------------------|
| Name | XCANPS_BRPR_OFFSET |
| Software Name | BRPR |
| Relative Address | 0x00000008 |
| Absolute Address | can0: 0xE0008008 can1: 0xE0009008 |
| Width | 32 bits |
| Access Type | rw |
| Reset Value | 0x00000000 |
| Description | Baud Rate Prescaler Register |

Register XCANPS_BRPR_OFFSET Details

The BRPR can be programmed to any value in the range 0-255. The actual value is 1 more than the value written into the register.

Please refer to the CAN chapter for more details.

| Field Name | Bits | Type | Reset Value | Description |
|-----------------------------------|------|------|-------------|--|
| reserved | 31:8 | rw | 0x0 | Reserved |
| XCANPS_BRPR_BRP_M ASK (BRP) | 7:0 | rw | 0x0 | Baud Rate Prescaler These bits indicate the prescaler value. The actual value ranges from 1 to 256. |

Register ([can](#)) XCANPS_BTR_OFFSET

| | |
|------------------|--------------------------------------|
| Name | XCANPS_BTR_OFFSET |
| Software Name | BTR |
| Relative Address | 0x0000000C |
| Absolute Address | can0: 0xE000800C can1: 0xE000900C |
| Width | 32 bits |
| Access Type | rw |
| Reset Value | 0x00000000 |
| Description | Bit Timing Register |

Register XCANPS_BTR_OFFSET Details

The Bit Timing Register (BTR) specifies the bits needed to configure bit time. Specifically, the Propagation Segment, Phase segment 1, Phase segment 2, and Synchronization Jump Width (as defined in CAN 2.0A, CAN 2.0B and ISO 11891-1) are written to the BTR. The actual value of each of these fields is one more than the value written to this register.

| Field Name | Bits | Type | Reset Value | Description |
|----------------------------------|------|------|-------------|---|
| reserved | 31:9 | rw | 0x0 | Reserved |
| XCANPS_BTR_SJW_MAS K (SJW) | 8:7 | rw | 0x0 | Synchronization Jump Width Indicates the Synchronization Jump Width as specified in the CAN 2.0A and CAN 2.0B standard. The actual value is one more than the value written to the register. |
| XCANPS_BTR_TS2_MAS K (TS2) | 6:4 | rw | 0x0 | Time Segment 2 Indicates Phase Segment 2 as specified in the CAN 2.0A and CAN 2.0B standard. The actual value is one more than the value written to the register. |
| XCANPS_BTR_TS1_MAS K (TS1) | 3:0 | rw | 0x0 | Time Segment 1 Indicates the Sum of Propagation Segment and Phase Segment 1 as specified in the CAN 2.0A and CAN 2.0B standard. The actual value is one more than the value written to the register. |

Register ([can](#)) XCANPS_ECR_OFFSET

| | |
|------------------|--------------------------------------|
| Name | XCANPS_ECR_OFFSET |
| Software Name | ECR |
| Relative Address | 0x00000010 |
| Absolute Address | can0: 0xE0008010 can1: 0xE0009010 |
| Width | 32 bits |
| Access Type | ro |
| Reset Value | 0x00000000 |
| Description | Error Counter Register |

Register XCANPS_ECR_OFFSET Details

The ECR is a read-only register. Writes to the ECR have no effect. The value of the error counters in the register reflect the values of the transmit and receive error counters in the CAN Protocol Engine Module (see Figure 1).

The following conditions reset the Transmit and Receive Error counters:

- * When '1' is written to the SRST bit in the SRR
- * When '0' is written to the CEN bit in the SRR
- * When the CAN controller enters Bus Off state
- * During Bus Off recovery when the CAN controller enters Error Active state after 128 occurrences of 11 consecutive recessive bits

When in Bus Off recovery, the Receive Error counter is advanced by 1 when a sequence of 11 consecutive recessive bits is seen.

| Field Name | Bits | Type | Reset Value | Description |
|----------------------------------|-------|------|-------------|--|
| reserved | 31:16 | ro | 0x0 | Reserved |
| XCANPS_ECR_REC_MAS K (REC) | 15:8 | ro | 0x0 | Receive Error Counter Indicates the Value of the Receive Error Counter. |
| XCANPS_ECR_TEC_MAS K (TEC) | 7:0 | ro | 0x0 | Transmit Error Counter Indicates the Value of the Transmit Error Counter. |

Register ([can](#)) XCANPS_ESR_OFFSET

| | |
|---------------|-------------------|
| Name | XCANPS_ESR_OFFSET |
| Software Name | ESR |

| | |
|------------------|--------------------------------------|
| Relative Address | 0x00000014 |
| Absolute Address | can0: 0xE0008014 can1: 0xE0009014 |
| Width | 32 bits |
| Access Type | mixed |
| Reset Value | 0x00000000 |
| Description | Error Status Register |

Register XCANPS_ESR_OFFSET Details

The Error Status Register (ESR) indicates the type of error that has occurred on the bus. If more than one error occurs, all relevant error flag bits are set in this register. The ESR is a write-to-clear register. Writes to this register will not set any bits, but will clear the bits that are set.

| Field Name | Bits | Type | Reset Value | Description |
|--------------------------------------|------|------|-------------|---|
| reserved | 31:5 | rw | 0x0 | Reserved |
| XCANPS_ESR_ACKER_M ASK (ACKER) | 4 | wtc | 0x0 | ACK Error Indicates an acknowledgment error. 1: Indicates an acknowledgment error has occurred. 0: Indicates an acknowledgment error has not occurred on the bus since the last write to this register. If this bit is set, writing a 1 clears it. |
| XCANPS_ESR_BERR_MA SK (BERR) | 3 | wtc | 0x0 | Bit Error Indicates the received bit is not the same as the transmitted bit during bus communication. 1: Indicates a bit error has occurred. 0: Indicates a bit error has not occurred on the bus since the last write to this register. If this bit is set, writing a 1 clears it. |
| XCANPS_ESR_STER_MA SK (STER) | 2 | wtc | 0x0 | Stuff Error Indicates an error if there is a stuffing violation. 1: Indicates a stuff error has occurred. 0: Indicates a stuff error has not occurred on the bus since the last write to this register. If this bit is set, writing a 1 clears it. |

| Field Name | Bits | Type | Reset Value | Description |
|------------------------------|------|------|-------------|---|
| XCANPS_ESR_FMERMASK (FMER) | 1 | wtc | 0x0 | Form Error Indicates an error in one of the fixed form fields in the message frame. 1: Indicates a form error has occurred. 0: Indicates a form error has not occurred on the bus since the last write to this register. If this bit is set, writing a 1 clears it. |
| XCANPS_ESR_CRCERMASK (CRCER) | 0 | wtc | 0x0 | CRC Error Indicates a CRC error has occurred. 1: Indicates a CRC error has occurred. 0: Indicates a CRC error has not occurred on the bus since the last write to this register. If this bit is set, writing a 1 clears it. In case of a CRC Error and a CRC delimiter corruption, only the FMER bit is set. |

Register ([can](#)) XCANPS_SR_OFFSET

| | |
|------------------|--------------------------------------|
| Name | XCANPS_SR_OFFSET |
| Software Name | SR |
| Relative Address | 0x00000018 |
| Absolute Address | can0: 0xE0008018 can1: 0xE0009018 |
| Width | 32 bits |
| Access Type | mixed |
| Reset Value | 0x00000001 |
| Description | Status Register |

Register XCANPS_SR_OFFSET Details

The CAN Status Register provides a status of all conditions of the Core. Specifically, FIFO status, Error State, Bus State and Configuration mode are reported.

| Field Name | Bits | Type | Reset Value | Description |
|------------------------------|-------|------|-------------|--|
| reserved | 31:13 | rw | 0x0 | Reserved |
| XCANPS_SR_SNOOP_MASK (SNOOP) | 12 | ro | 0x0 | Snoop Mode Indicates the CAN controller is in Snoop Mode. 1: Indicates the CAN controller is in Snoop Mode. 0: Indicates the CAN controller is not in Snoop mode. |

| Field Name | Bits | Type | Reset Value | Description |
|-----------------------------------|------|------|-------------|--|
| XCANPS_SR_ACFBSY_MASK (ACFBSY) | 11 | ro | 0x0 | Acceptance Filter Busy indicator. Indicates write-ability of the Mask and ID registers, read-only: 0: writable 1: not writable. This bit reads 1 when a 0 is written to any of the valid UAF bits in an Acceptance Filter Register. |
| XCANPS_SR_TXFLL_MASK (TXFLL) | 10 | ro | 0x0 | Transmit FIFO Full Indicates that the TX FIFO is full. 1: Indicates the TX FIFO is full. 0: Indicates the TX FIFO is not full. |
| XCANPS_SR_TXBFLL_MASK (TXBFLL) | 9 | ro | 0x0 | High Priority Transmit Buffer Full Indicates the High Priority Transmit Buffer is full. 1: Indicates the High Priority Transmit Buffer is full. 0: Indicates the High Priority Transmit Buffer is not full. |
| XCANPS_SR_ESTAT_MASK (ESTAT) | 8:7 | ro | 0x0 | Error Status Indicates the error status of the CAN controller. 00: Indicates Configuration Mode (CONFIG = 1). Error State is undefined. 01: Indicates Error Active State. 11: Indicates Error Passive State. 10: Indicates Bus Off State. |
| XCANPS_SR_ERRWRN_MASK (ERRWRN) | 6 | ro | 0x0 | Error Warning Indicates that either the Transmit Error counter or the Receive Error counter has exceeded a value of 96. 1: One or more error counters have a value greater than or equal to 96. 0: Neither of the error counters has a value greater than or equal to 96. |
| XCANPS_SR_BBSY_MASK (BBSY) | 5 | ro | 0x0 | Bus Busy Indicates the CAN bus status. 1: Indicates that the CAN controller is either receiving a message or transmitting a message. 0: Indicates that the CAN controller is either in Configuration mode or the bus is idle. |
| XCANPS_SR_BIDLE_MASK (BIDLE) | 4 | ro | 0x0 | Bus Idle Indicates the CAN bus status. 1: Indicates no bus communication is taking place. 0: Indicates the CAN controller is either in Configuration mode or the bus is busy. |

| Field Name | Bits | Type | Reset Value | Description |
|-----------------------------------|------|------|-------------|--|
| XCANPS_SR_NORMAL_MASK (NORMAL) | 3 | ro | 0x0 | Normal Mode Indicates the CAN controller is in Normal Mode. 1: Indicates the CAN controller is in Normal Mode. 0: Indicates the CAN controller is not in Normal mode. |
| XCANPS_SR_SLEEP_MASK (SLEEP) | 2 | ro | 0x0 | Sleep Mode Indicates the CAN controller is in Sleep mode. 1: Indicates the CAN controller is in Sleep mode. 0: Indicates the CAN controller is not in Sleep mode. |
| XCANPS_SR_LBACK_MASK (LBACK) | 1 | ro | 0x0 | Loop Back Mode Indicates the CAN controller is in Loop Back mode. 1: Indicates the CAN controller is in Loop Back mode. 0: Indicates the CAN controller is not in Loop Back mode. |
| XCANPS_SR_CONFIG_MASK (CONFIG) | 0 | ro | 0x1 | Configuration Mode Indicator Indicates the CAN controller is in Configuration mode. 1: Indicates the CAN controller is in Configuration mode. 0: Indicates the CAN controller is not in Configuration mode. |

Register ([can](#)) XCANPS_ISR_OFFSET

| | |
|------------------|--------------------------------------|
| Name | XCANPS_ISR_OFFSET |
| Software Name | ISR |
| Relative Address | 0x0000001C |
| Absolute Address | can0: 0xE000801C can1: 0xE000901C |
| Width | 32 bits |
| Access Type | mixed |
| Reset Value | 0x00006000 |
| Description | Interrupt Status Register |

Register XCANPS_ISR_OFFSET Details

The Interrupt Status Register (ISR) contains bits that are set when a particular interrupt condition occurs. If the corresponding mask bit in the Interrupt Enable Register is set, an interrupt is generated.

Interrupt bits in the ISR can be cleared by writing to the Interrupt Clear Register. For all bits in the ISR, a set condition takes priority over the clear condition and the bit continues to remain '1.'

| Field Name | Bits | Type | Reset Value | Description |
|--|-------|------|-------------|--|
| reserved | 31:15 | rw | 0x0 | reserved |
| XCANPS_IXR_TXFEMP_MASK (IXR_TXFEMP) | 14 | ro | 0x1 | Transmit FIFO Empty Interrupt A 1 indicates that the Transmit FIFO is empty. The interrupt continues to assert as long as the TX FIFO is empty. This bit can be cleared only by writing to the ICR. |
| XCANPS_IXR_TXFWMEMP_MASK (IXR_TXFWMEMP) | 13 | ro | 0x1 | Transmit FIFO Watermark Empty Interrupt A 1 indicates that the TX FIFO is empty based on watermark programming. The interrupt continues to assert as long as the number of empty spaces in the TX FIFO is greater than TX FIFO empty watermark. This bit can be cleared only by writing to the Interrupt Clear Register. |
| XCANPS_IXR_RXFWMFL_MASK (IXR_RXFWMFL) | 12 | ro | 0x0 | Receive FIFO Watermark Full Interrupt A 1 indicates that the RX FIFO is full based on watermark programming. The interrupt continues to assert as long as the RX FIFO count is above RX FIFO Full watermark. This bit can be cleared only by writing to the Interrupt Clear Register. |
| XCANPS_IXR_WKUP_MASK (IXR_WKUP) | 11 | ro | 0x0 | Wake up Interrupt A 1 indicates that the CAN controller entered Normal mode from Sleep Mode. This bit can be cleared by writing to the ICR. This bit is also cleared when a 0 is written to the CEN bit in the SRR. |
| XCANPS_IXR_SLP_MASK (IXR_SLP) | 10 | ro | 0x0 | Sleep Interrupt A 1 indicates that the CAN controller entered Sleep mode. This bit can be cleared by writing to the ICR. This bit is also cleared when a 0 is written to the CEN bit in the SRR. |
| XCANPS_IXR_BSOFF_MASK (IXR_BSOFF) | 9 | ro | 0x0 | Bus Off Interrupt A 1 indicates that the CAN controller entered the Bus Off state. This bit can be cleared by writing to the ICR. This bit is also cleared when a 0 is written to the CEN bit in the SRR. |
| XCANPS_IXR_ERROR_MASK (IXR_ERROR) | 8 | ro | 0x0 | Error Interrupt A 1 indicates that an error occurred during message transmission or reception. This bit can be cleared by writing to the ICR. This bit is also cleared when a 0 is written to the CEN bit in the SRR. |

| Field Name | Bits | Type | Reset Value | Description |
|--|------|------|-------------|--|
| XCANPS_IXR_RXNEMP_MASK (IXR_RXNEMP) | 7 | ro | 0x0 | Receive FIFO Not Empty Interrupt A 1 indicates that the Receive FIFO is not empty. This bit can be cleared only by writing to the ICR. |
| XCANPS_IXR_RXOFLW_MASK (IXR_RXOFLW) | 6 | ro | 0x0 | RX FIFO Overflow Interrupt A 1 indicates that a message has been lost. This condition occurs when a new message is being received and the Receive FIFO is Full. This bit can be cleared by writing to the ICR. This bit is also cleared when a 0 is written to the CEN bit in the SRR. |
| XCANPS_IXR_RXUFLW_MASK (IXR_RXUFLW) | 5 | ro | 0x0 | RX FIFO Underflow Interrupt A 1 indicates that a read operation was attempted on an empty RX FIFO. This bit can be cleared only by writing to the ICR. |
| XCANPS_IXR_RXOK_MASK (IXR_RXOK) | 4 | ro | 0x0 | New Message Received Interrupt A 1 indicates that a message was received successfully and stored into the RX FIFO. This bit can be cleared by writing to the ICR. This bit is also cleared when a 0 is written to the CEN bit in the SRR. |
| XCANPS_IXR_TXBFLM_MASK (IXR_TXBFLM) | 3 | ro | 0x0 | High Priority Transmit Buffer Full Interrupt A 1 indicates that the High Priority Transmit Buffer is full. The status of the bit is unaffected if write transactions occur on the High Priority Transmit Buffer when it is already full. This bit can be cleared only by writing to the ICR. |
| XCANPS_IXR_TXFLM_MASK (IXR_TXFLM) | 2 | ro | 0x0 | Transmit FIFO Full Interrupt A 1 indicates that the TX FIFO is full. The status of the bit is unaffected if write transactions occur on the Transmit FIFO when it is already full. This bit can be cleared only by writing to the Interrupt Clear Register. |
| XCANPS_IXR_TXOK_MASK (IXR_TXOK) | 1 | ro | 0x0 | Transmission Successful Interrupt A 1 indicates that a message was transmitted successfully. This bit can be cleared by writing to the ICR. This bit is also cleared when a 0 is written to the CEN bit in the SRR. In Loop Back mode, both TXOK and RXOK bits are set. The RXOK bit is set before the TXOK bit. |
| XCANPS_IXR_ARBLST_MASK (IXR_ARBLST) | 0 | ro | 0x0 | Arbitration Lost Interrupt A 1 indicates that arbitration was lost during message transmission. This bit can be cleared by writing to the ICR. This bit is also cleared when a 0 is written to the CEN bit in the SRR. |

Register ([can](#)) XCANPS_IER_OFFSET

| | |
|------------------|--------------------------------------|
| Name | XCANPS_IER_OFFSET |
| Software Name | IER |
| Relative Address | 0x00000020 |
| Absolute Address | can0: 0xE0008020 can1: 0xE0009020 |
| Width | 32 bits |
| Access Type | rw |
| Reset Value | 0x00000000 |
| Description | Interrupt Enable Register |

Register XCANPS_IER_OFFSET Details

| Field Name | Bits | Type | Reset Value | Description |
|---|-------|------|-------------|--|
| reserved | 31:15 | rw | 0x0 | Reserved |
| XCANPS_IXR_TXFEMP_MASK (IXR_TXFEMP) | 14 | rw | 0x0 | Enable TXFIFO Empty Interrupt Writes to this bit enable or disable interrupts when the TXFEMP bit in the ISR is set. 1: Enable interrupt generation if TXFEMP bit in ISR is set. 0: Disable interrupt generation if TXFEMP bit in ISR is set. |
| XCANPS_IXR_TXFWEMP_MASK (IXR_TXFWMEMP) | 13 | rw | 0x0 | Enable TXFIFO watermark Empty Interrupt Writes to this bit enable or disable interrupts when the TXFWMEMP bit in the ISR is set. 1: Enable interrupt generation if TXFWMEMP bit in ISR is set. 0: Disable interrupt generation if TXFWMEMP bit in ISR is set. |
| XCANPS_IXR_RXFWMFL_MASK (IXR_RXFWMFLL) | 12 | rw | 0x0 | Enable RXFIFO watermark Full Interrupt Writes to this bit enable or disable interrupts when the RXFLL bit in the ISR is set. 1: Enable interrupt generation if RXFWMFLL bit in ISR is set. 0: Disable interrupt generation if RXFWMFLL bit in ISR is set. |
| XCANPS_IXR_WKUP_MASK (IXR_WKUP) | 11 | rw | 0x0 | Enable Wake up Interrupt Writes to this bit enable or disable interrupts when the WKUP bit in the ISR is set. 1: Enable interrupt generation if WKUP bit in ISR is set. 0: Disable interrupt generation if WKUP bit in ISR is set. |

| Field Name | Bits | Type | Reset Value | Description |
|--|------|------|-------------|--|
| XCANPS_IXR_SLP_MASK (IXR_SLP) | 10 | rw | 0x0 | Enable Sleep Interrupt Writes to this bit enable or disable interrupts when the SLP bit in the ISR is set. 1: Enable interrupt generation if SLP bit in ISR is set. 0: Disable interrupt generation if SLP bit in ISR is set. |
| XCANPS_IXR_BSOFF_MASK (IXR_BSOFF) | 9 | rw | 0x0 | Enable Bus OFF Interrupt Writes to this bit enable or disable interrupts when the BSOFF bit in the ISR is set. 1: Enable interrupt generation if BSOFF bit in ISR is set. 0: Disable interrupt generation if BSOFF bit in ISR is set. |
| XCANPS_IXR_ERROR_MASK (IXR_ERROR) | 8 | rw | 0x0 | Enable Error Interrupt Writes to this bit enable or disable interrupts when the ERROR bit in the ISR is set. 1: Enable interrupt generation if ERROR bit in ISR is set. 0: Disable interrupt generation if ERROR bit in ISR is set. |
| XCANPS_IXR_RXNEMP_MASK (IXR_RXNEMP) | 7 | rw | 0x0 | Enable Receive FIFO Not Empty Interrupt Writes to this bit enable or disable interrupts when the RXNEMP bit in the ISR is set. 1: Enable interrupt generation if RXNEMP bit in ISR is set. 0: Disable interrupt generation if RXNEMP bit in ISR is set. |
| XCANPS_IXR_RXOFLW_MASK (IXR_RXOFLW) | 6 | rw | 0x0 | Enable RX FIFO Overflow Interrupt Writes to this bit enable or disable interrupts when the RXOFLW bit in the ISR is set. 1: Enable interrupt generation if RXOFLW bit in ISR is set. 0: Disable interrupt generation if RXOFLW bit in ISR is set. |
| XCANPS_IXR_RXUFLW_MASK (IXR_RXUFLW) | 5 | rw | 0x0 | Enable RX FIFO Underflow Interrupt Writes to this bit enable or disable interrupts when the RXUFLW bit in the ISR is set. 1: Enable interrupt generation if RXUFLW bit in ISR is set. 0: Disable interrupt generation if RXUFLW bit in ISR is set. |
| XCANPS_IXR_RXOK_MASK (IXR_RXOK) | 4 | rw | 0x0 | Enable New Message Received Interrupt Writes to this bit enable or disable interrupts when the RXOK bit in the ISR is set. 1: Enable interrupt generation if RXOK bit in ISR is set. 0: Disable interrupt generation if RXOK bit in ISR is set. |

| Field Name | Bits | Type | Reset Value | Description |
|--|------|------|-------------|--|
| XCANPS_IXR_TXBFLLMASK (IXR_TXBFLM) | 3 | rw | 0x0 | Enable High Priority Transmit Buffer Full Interrupt Writes to this bit enable or disable interrupts when the TXBFLM bit in the ISR is set. 1: Enable interrupt generation if TXBFLM bit in ISR is set. 0: Disable interrupt generation if TXBFLM bit in ISR is set. |
| XCANPS_IXR_TXFLLMASK (IXR_TXFLLM) | 2 | rw | 0x0 | Enable Transmit FIFO Full Interrupt Writes to this bit enable or disable interrupts when TXFLLM bit in the ISR is set. 1: Enable interrupt generation if TXFLLM bit in ISR is set. 0: Disable interrupt generation if TXFLLM bit in ISR is set. |
| XCANPS_IXR_TXOKMASK (IXR_TXOKM) | 1 | rw | 0x0 | Enable Transmission Successful Interrupt Writes to this bit enable or disable interrupts when the TXOK bit in the ISR is set. 1: Enable interrupt generation if TXOK bit in ISR is set. 0: Disable interrupt generation if TXOK bit in ISR is set. |
| XCANPS_IXR_ARBLSTMASK (IXR_ARBLSTM) | 0 | rw | 0x0 | Enable Arbitration Lost Interrupt Writes to this bit enable or disable interrupts when the ARBLSTM bit in the ISR is set. 1: Enable interrupt generation if ARBLSTM bit in ISR is set. 0: Disable interrupt generation if ARBLSTM bit in ISR is set. |

Register ([can](#)) XCANPS_ICR_OFFSET

| | |
|------------------|--------------------------------------|
| Name | XCANPS_ICR_OFFSET |
| Software Name | ICR |
| Relative Address | 0x00000024 |
| Absolute Address | can0: 0xE0008024 can1: 0xE0009024 |
| Width | 32 bits |
| Access Type | mixed |
| Reset Value | 0x00000000 |
| Description | Interrupt Clear Register |

Register XCANPS_ICR_OFFSET Details

| Field Name | Bits | Type | Reset Value | Description |
|--|-------|------|-------------|---|
| reserved | 31:15 | rw | 0x0 | Reserved |
| XCANPS_IXR_TXFEMP_MASK (IXR_TXFEMP) | 14 | wo | 0x0 | Clear TXFIFO Empty Interrupt Writing a 1 to this bit clears the TXFEMP bit in the ISR. |
| XCANPS_IXR_TXFWEMP_MASK (IXR_TXFWEMP) | 13 | wo | 0x0 | Clear TXFIFO Watermark Empty Interrupt Writing a 1 to this bit clears the TXFWEMP bit in the ISR. |
| XCANPS_IXR_RXFWMFLL_MASK (IXR_RXFWMFLL) | 12 | wo | 0x0 | Clear RXFIFO Watermark Full Interrupt Writing a 1 to this bit clears the RXFWMFLL bit in the ISR. |
| XCANPS_IXR_WKUP_MASK (IXR_WKUP) | 11 | wo | 0x0 | Clear Wake up Interrupt Writing a 1 to this bit clears the WKUP bit in the ISR. |
| XCANPS_IXR_SLP_MASK (IXR_SLP) | 10 | wo | 0x0 | Clear Sleep Interrupt Writing a 1 to this bit clears the SLP bit in the ISR. |
| XCANPS_IXR_BSOFF_MASK (IXR_BSOFF) | 9 | wo | 0x0 | Clear Bus Off Interrupt Writing a 1 to this bit clears the BSOFF bit in the ISR. |
| XCANPS_IXR_ERROR_MASK (IXR_ERROR) | 8 | wo | 0x0 | Clear Error Interrupt Writing a 1 to this bit clears the ERROR bit in the ISR. |
| XCANPS_IXR_RXNEMP_MASK (IXR_RXNEMP) | 7 | wo | 0x0 | Clear Receive FIFO Not Empty Interrupt Writing a 1 to this bit clears the RXNEMP bit in the ISR. |
| XCANPS_IXR_RXOFLW_MASK (IXR_RXOFLW) | 6 | wo | 0x0 | Clear RX FIFO Overflow Interrupt Writing a 1 to this bit clears the RXOFLW bit in the ISR. |
| XCANPS_IXR_RXUFLW_MASK (IXR_RXUFLW) | 5 | wo | 0x0 | Clear RX FIFO Underflow Interrupt Writing a 1 to this bit clears the RXUFLW bit in the ISR. |
| XCANPS_IXR_RXOK_MASK (IXR_RXOK) | 4 | wo | 0x0 | Clear New Message Received Interrupt Writing a 1 to this bit clears the RXOK bit in the ISR. |
| XCANPS_IXR_TXBFLL_MASK (IXR_TXBFLL) | 3 | wo | 0x0 | Clear High Priority Transmit Buffer Full Interrupt Writing a 1 to this bit clears the TXBFLL bit in the ISR. |
| XCANPS_IXR_TXFLL_MASK (IXR_TXFLL) | 2 | wo | 0x0 | Clear Transmit FIFO Full Interrupt Writing a 1 to this bit clears the TXFLL bit in the ISR. |

| Field Name | Bits | Type | Reset Value | Description |
|--|------|------|-------------|---|
| XCANPS_IXR_TXOK_MASK (IXR_TXOK) | 1 | wo | 0x0 | Clear Transmission Successful Interrupt Writing a 1 to this bit clears the CTXOK bit in the ISR. |
| XCANPS_IXR_ARBLST_MASK (IXR_ARBLST) | 0 | wo | 0x0 | Clear Arbitration Lost Interrupt Writing a 1 to this bit clears the ARBLST bit in the ISR. |

Register ([can](#)) XCANPS_TCR_OFFSET

| | |
|------------------|--------------------------------------|
| Name | XCANPS_TCR_OFFSET |
| Software Name | TCR |
| Relative Address | 0x00000028 |
| Absolute Address | can0: 0xE0008028 can1: 0xE0009028 |
| Width | 32 bits |
| Access Type | mixed |
| Reset Value | 0x00000000 |
| Description | Timestamp Control Register |

Register XCANPS_TCR_OFFSET Details

| Field Name | Bits | Type | Reset Value | Description |
|------------------------------|------|------|-------------|--|
| reserved | 31:1 | rw | 0x0 | reserved |
| XCANPS_TCR_CTS_MASK (CTS) | 0 | wo | 0x0 | Clear Timestamp Internal free running counter is cleared to 0 when CTS=1. This bit only needs to be written once with a 1 to clear the counter. The bit will automatically return to 0. |

Register ([can](#)) XCANPS_WIR_OFFSET

| | |
|------------------|--------------------------------------|
| Name | XCANPS_WIR_OFFSET |
| Software Name | WIR |
| Relative Address | 0x0000002C |
| Absolute Address | can0: 0xE000802C can1: 0xE000902C |
| Width | 32 bits |
| Access Type | rw |
| Reset Value | 0x00003F3F |

Description Watermark Interrupt Register

Register XCANPS_WIR_OFFSET Details

The TXFIFO Empty watermark (EW) programmed in this register will be applied to TX FIFO only. The RXFIFO Full watermark (FW) programmed in this register will be applied to RX FIFO only. The watermark register is allowed to program only when CEN=0 in SRR register.

The TXFIFO Watermark EMPTY interrupt (TXFWMEMP) will continue to assert as long as the number of empty spaces in the TX FIFO is greater than the TXFIFO Empty watermark (EW). The RXFLL interrupt will continue to assert as long as the RX FIFO count remains above the RXFIFO Full watermark (FW).

| Field Name | Bits | Type | Reset Value | Description |
|--------------------------------|-------|------|-------------|---|
| reserved | 31:16 | rw | 0x0 | reserved |
| XCANPS_WIR_EW_MAS K (EW) | 15:8 | rw | 0x3F | TXFIFO Empty watermark TXFIFO generates an EMPTY interrupt based on the value programmed in this field. The valid range is (1-63). No protection is given for illegal programming in this field. This field can be written to only when CEN bit in SRR is 0. |
| XCANPS_WIR_FW_MAS K (FW) | 7:0 | rw | 0x3F | RXFIFO Full watermark RXFIFO generates FULL interrupt based on the value programmed in this field. The valid range is (1-63). No protection is given for illegal programming in this field. This field can be written to only when CEN bit in SRR is 0. |

Register ([can](#)) XCANPS_TXFIFO_ID_OFFSET

Name XCANPS_TXFIFO_ID_OFFSET
 Software Name TXFIFO_ID
 Relative Address 0x00000030
 Absolute Address can0: 0xE0008030
 can1: 0xE0009030
 Width 32 bits
 Access Type wo
 Reset Value 0x00000000
 Description transmit message fifo message identifier

Register XCANPS_TXFIFO_ID_OFFSET Details

| Field Name | Bits | Type | Reset Value | Description |
|--------------------------------------|-------|------|-------------|--|
| XCANPS_IDR_ID1_MAS K (IDR_ID1) | 31:21 | wo | 0x0 | Standard Message ID The Identifier portion for a Standard Frame is 11 bits. These bits indicate the Standard Frame ID. This field is valid for both Standard and Extended Frames. |
| XCANPS_IDR_SRR_MAS K (IDR_SRR) | 20 | wo | 0x0 | Substitute Remote Transmission Request This bit differentiates between data frames and remote frames. Valid only for Standard Frames. For Extended frames, if writing '1' it sends '1' and if writing '0' it sends '0'. 1: Indicates that the message frame is a Remote Frame. 0: Indicates that the message frame is a Data Frame. |
| XCANPS_IDR_IDE_MAS K (IDR_IDE) | 19 | wo | 0x0 | Identifier Extension This bit differentiates between frames using the Standard Identifier and those using the Extended Identifier. Valid for both Standard and Extended Frames. 1: Indicates the use of an Extended Message Identifier. 0: Indicates the use of a Standard Message Identifier. |
| XCANPS_IDR_ID2_MAS K (IDR_ID2) | 18:1 | wo | 0x0 | Extended Message ID This field indicates the Extended Identifier. Valid only for Extended Frames. For Standard Frames, reads from this field return 0s. For Standard Frames, writes to this field should be 0s. |
| XCANPS_IDR_RTR_MAS K (IDR_RTR) | 0 | wo | 0x0 | Remote Transmission Request This bit differentiates between data frames and remote frames. Valid only for Extended Frames. 1: Indicates the message object is a Remote Frame 0: Indicates the message object is a Data Frame For Standard Frames, reads from this bit returns 0 For Standard Frames, writes to this bit should be 0 |

Register ([can](#)) XCANPS_TXFIFO_DLC_OFFSET

Name XCANPS_TXFIFO_DLC_OFFSET
 Software Name TXFIFO_DLC
 Relative Address 0x00000034
 Absolute Address can0: 0xE0008034
 can1: 0xE0009034
 Width 32 bits

Access Type rw
 Reset Value 0x00000000
 Description transmit message fifo data length code

Register XCANPS_TXFIFO_DLC_OFFSET Details

| Field Name | Bits | Type | Reset Value | Description |
|--|-------|------|-------------|---|
| XCANPS_DLCR_DLC_M ASK (DLCR_DLC) | 31:28 | rw | 0x0 | Data Length Code This is the data length portion of the control field of the CAN frame. This indicates the number valid data bytes in Data Word 1 and Data Word 2 registers. |
| reserved | 27:0 | rw | 0x0 | reserved |

Register ([can](#)) XCANPS_TXFIFO_DW1_OFFSET

Name XCANPS_TXFIFO_DW1_OFFSET
 Software Name TXFIFO_DW1
 Relative Address 0x00000038
 Absolute Address can0: 0xE0008038
 can1: 0xE0009038
 Width 32 bits
 Access Type rw
 Reset Value 0x00000000
 Description transmit message fifo data word 1

Register XCANPS_TXFIFO_DW1_OFFSET Details

| Field Name | Bits | Type | Reset Value | Description |
|--|-------|------|-------------|--|
| XCANPS_DW1R_DB0_M ASK (DW1R_DB0) | 31:24 | rw | 0x0 | Data Byte 0 Reads from this field return invalid data if the message has no data. |
| XCANPS_DW1R_DB1_M ASK (DW1R_DB1) | 23:16 | rw | 0x0 | Data Byte 1 Reads from this field return invalid data if the message has only 1 byte of data or fewer |
| XCANPS_DW1R_DB2_M ASK (DW1R_DB2) | 15:8 | rw | 0x0 | Data Byte 2 Reads from this field return invalid data if the message has only 2 byte of data or fewer |
| XCANPS_DW1R_DB3_M ASK (DW1R_DB3) | 7:0 | rw | 0x0 | Data Byte 3 Reads from this field return invalid data if the message has only 3 byte of data or fewer |

Register ([can](#)) XCANPS_TXFIFO_DW2_OFFSET

| | |
|------------------|--------------------------------------|
| Name | XCANPS_TXFIFO_DW2_OFFSET |
| Software Name | TXFIFO_DW2 |
| Relative Address | 0x0000003C |
| Absolute Address | can0: 0xE000803C can1: 0xE000903C |
| Width | 32 bits |
| Access Type | rw |
| Reset Value | 0x00000000 |
| Description | transmit message fifo data word 2 |

Register XCANPS_TXFIFO_DW2_OFFSET Details

| Field Name | Bits | Type | Reset Value | Description |
|----------------------------------|-------|------|-------------|--|
| XCANPS_DW2R_DB4_M ASK (DW2R_DB4) | 31:24 | rw | 0x0 | Data Byte 4 Reads from this field return invalid data if the message has only 4 byte of data or fewer |
| XCANPS_DW2R_DB5_M ASK (DW2R_DB5) | 23:16 | rw | 0x0 | Data Byte 5 Reads from this field return invalid data if the message has only 5 byte of data or fewer |
| XCANPS_DW2R_DB6_M ASK (DW2R_DB6) | 15:8 | rw | 0x0 | Data Byte 6 Reads from this field return invalid data if the message has only 6 byte of data or fewer |
| XCANPS_DW2R_DB7_M ASK (DW2R_DB7) | 7:0 | rw | 0x0 | Data Byte 7 Reads from this field return invalid data if the message has 7 byte of data or fewer |

Register ([can](#)) XCANPS_TXHPB_ID_OFFSET

| | |
|------------------|--|
| Name | XCANPS_TXHPB_ID_OFFSET |
| Software Name | TXHPB_ID |
| Relative Address | 0x00000040 |
| Absolute Address | can0: 0xE0008040 can1: 0xE0009040 |
| Width | 32 bits |
| Access Type | wo |
| Reset Value | 0x00000000 |
| Description | transmit high priority buffer message identifier |

Register XCANPS_TXHPB_ID_OFFSET Details

| Field Name | Bits | Type | Reset Value | Description |
|--------------------------------------|-------|------|-------------|--|
| XCANPS_IDR_ID1_MAS K (IDR_ID1) | 31:21 | wo | 0x0 | Standard Message ID The Identifier portion for a Standard Frame is 11 bits. These bits indicate the Standard Frame ID. This field is valid for both Standard and Extended Frames. |
| XCANPS_IDR_SRR_MAS K (IDR_SRR) | 20 | wo | 0x0 | Substitute Remote Transmission Request This bit differentiates between data frames and remote frames. Valid only for Standard Frames. For Extended frames, if writing '1' it sends '1' and if writing '0' it sends '0'. 1: Indicates that the message frame is a Remote Frame. 0: Indicates that the message frame is a Data Frame. |
| XCANPS_IDR_IDE_MAS K (IDR_IDE) | 19 | wo | 0x0 | Identifier Extension This bit differentiates between frames using the Standard Identifier and those using the Extended Identifier. Valid for both Standard and Extended Frames. 1: Indicates the use of an Extended Message Identifier. 0: Indicates the use of a Standard Message Identifier. |
| XCANPS_IDR_ID2_MAS K (IDR_ID2) | 18:1 | wo | 0x0 | Extended Message ID This field indicates the Extended Identifier. Valid only for Extended Frames. For Standard Frames, reads from this field return 0s. For Standard Frames, writes to this field should be 0s. |
| XCANPS_IDR_RTR_MAS K (IDR_RTR) | 0 | wo | 0x0 | Remote Transmission Request This bit differentiates between data frames and remote frames. Valid only for Extended Frames. 1: Indicates the message object is a Remote Frame 0: Indicates the message object is a Data Frame For Standard Frames, reads from this bit returns 0 For Standard Frames, writes to this bit should be 0 |

Register ([can](#)) XCANPS_TXHPB_DLC_OFFSET

Name XCANPS_TXHPB_DLC_OFFSET
 Software Name TXHPB_DLC
 Relative Address 0x00000044
 Absolute Address can0: 0xE0008044
 can1: 0xE0009044
 Width 32 bits

Access Type rw
 Reset Value 0x00000000
 Description transmit high priority buffer data length code

Register XCANPS_TXHPB_DLC_OFFSET Details

| Field Name | Bits | Type | Reset Value | Description |
|--|-------|------|-------------|---|
| XCANPS_DLCR_DLC_M ASK (DLCR_DLC) | 31:28 | rw | 0x0 | Data Length Code This is the data length portion of the control field of the CAN frame. This indicates the number valid data bytes in Data Word 1 and Data Word 2 registers. |
| reserved | 27:0 | rw | 0x0 | reserved |

Register ([can](#)) XCANPS_TXHPB_DW1_OFFSET

Name XCANPS_TXHPB_DW1_OFFSET
 Software Name TXHPB_DW1
 Relative Address 0x00000048
 Absolute Address can0: 0xE0008048
 can1: 0xE0009048
 Width 32 bits
 Access Type rw
 Reset Value 0x00000000
 Description transmit high priority buffer data word 1

Register XCANPS_TXHPB_DW1_OFFSET Details

| Field Name | Bits | Type | Reset Value | Description |
|--|-------|------|-------------|--|
| XCANPS_DW1R_DB0_M ASK (DW1R_DB0) | 31:24 | rw | 0x0 | Data Byte 0 Reads from this field return invalid data if the message has no data. |
| XCANPS_DW1R_DB1_M ASK (DW1R_DB1) | 23:16 | rw | 0x0 | Data Byte 1 Reads from this field return invalid data if the message has only 1 byte of data or fewer |
| XCANPS_DW1R_DB2_M ASK (DW1R_DB2) | 15:8 | rw | 0x0 | Data Byte 2 Reads from this field return invalid data if the message has only 2 byte of data or fewer |
| XCANPS_DW1R_DB3_M ASK (DW1R_DB3) | 7:0 | rw | 0x0 | Data Byte 3 Reads from this field return invalid data if the message has only 3 byte of data or fewer |

Register ([can](#)) XCANPS_TXHPB_DW2_OFFSET

| | |
|------------------|---|
| Name | XCANPS_TXHPB_DW2_OFFSET |
| Software Name | TXHPB_DW2 |
| Relative Address | 0x0000004C |
| Absolute Address | can0: 0xE000804C can1: 0xE000904C |
| Width | 32 bits |
| Access Type | rw |
| Reset Value | 0x00000000 |
| Description | transmit high priority buffer data word 2 |

Register XCANPS_TXHPB_DW2_OFFSET Details

| Field Name | Bits | Type | Reset Value | Description |
|----------------------------------|-------|------|-------------|--|
| XCANPS_DW2R_DB4_M ASK (DW2R_DB4) | 31:24 | rw | 0x0 | Data Byte 4 Reads from this field return invalid data if the message has only 4 byte of data or fewer |
| XCANPS_DW2R_DB5_M ASK (DW2R_DB5) | 23:16 | rw | 0x0 | Data Byte 5 Reads from this field return invalid data if the message has only 5 byte of data or fewer |
| XCANPS_DW2R_DB6_M ASK (DW2R_DB6) | 15:8 | rw | 0x0 | Data Byte 6 Reads from this field return invalid data if the message has only 6 byte of data or fewer |
| XCANPS_DW2R_DB7_M ASK (DW2R_DB7) | 7:0 | rw | 0x0 | Data Byte 7 Reads from this field return invalid data if the message has 7 byte of data or fewer |

Register ([can](#)) XCANPS_RXFIFO_ID_OFFSET

| | |
|------------------|---|
| Name | XCANPS_RXFIFO_ID_OFFSET |
| Software Name | RXFIFO_ID |
| Relative Address | 0x00000050 |
| Absolute Address | can0: 0xE0008050 can1: 0xE0009050 |
| Width | 32 bits |
| Access Type | ro |
| Reset Value | x |
| Description | receive message fifo message identifier |

Register XCANPS_RXFIFO_ID_OFFSET Details

| Field Name | Bits | Type | Reset Value | Description |
|--------------------------------------|-------|------|-------------|---|
| XCANPS_IDR_ID1_MAS K (IDR_ID1) | 31:21 | ro | x | Standard Message ID The Identifier portion for a Standard Frame is 11 bits. These bits indicate the Standard Frame ID. This field is valid for both Standard and Extended Frames. |
| XCANPS_IDR_SRR_MAS K (IDR_SRR) | 20 | ro | x | Substitute Remote Transmission Request This bit differentiates between data frames and remote frames. Valid only for Standard Frames. For Extended frames this bit is 1. 1: Indicates that the message frame is a Remote Frame. 0: Indicates that the message frame is a Data Frame. |
| XCANPS_IDR_IDE_MAS K (IDR_IDE) | 19 | ro | x | Identifier Extension This bit differentiates between frames using the Standard Identifier and those using the Extended Identifier. Valid for both Standard and Extended Frames. 1: Indicates the use of an Extended Message Identifier. 0: Indicates the use of a Standard Message Identifier. |
| XCANPS_IDR_ID2_MAS K (IDR_ID2) | 18:1 | ro | x | Extended Message ID This field indicates the Extended Identifier. Valid only for Extended Frames. For Standard Frames, reads from this field return 0s For Standard Frames, writes to this field should be 0s |
| XCANPS_IDR_RTR_MAS K (IDR_RTR) | 0 | ro | x | Remote Transmission Request This bit differentiates between data frames and remote frames. Valid only for Extended Frames. 1: Indicates the message object is a Remote Frame 0: Indicates the message object is a Data Frame For Standard Frames, reads from this bit returns 0 For Standard Frames, writes to this bit should be 0 |

Register ([can](#)) XCANPS_RXFIFO_DLC_OFFSET

Name XCANPS_RXFIFO_DLC_OFFSET
 Software Name RXFIFO_DLC
 Relative Address 0x00000054

Absolute Address can0: 0xE0008054
 can1: 0xE0009054

Width 32 bits

Access Type rw

Reset Value x

Description receive message fifo data length code

Register XCANPS_RXFIFO_DLC_OFFSET Details

| Field Name | Bits | Type | Reset Value | Description |
|----------------------------------|-------|------|-------------|---|
| XCANPS_DLCR_DLC_M ASK (DLCR_DLC) | 31:28 | rw | x | Data Length Code This is the data length portion of the control field of the CAN frame. This indicates the number valid data bytes in Data Word 1 and Data Word 2 registers. |
| reserved | 27:16 | rw | x | reserved |
| RXT | 15:0 | rw | x | RX Timestamp |

Register ([can](#)) XCANPS_RXFIFO_DW1_OFFSET

Name XCANPS_RXFIFO_DW1_OFFSET

Software Name RXFIFO_DW1

Relative Address 0x00000058

Absolute Address can0: 0xE0008058
 can1: 0xE0009058

Width 32 bits

Access Type rw

Reset Value x

Description receive message fifo data word 1

Register XCANPS_RXFIFO_DW1_OFFSET Details

| Field Name | Bits | Type | Reset Value | Description |
|----------------------------------|-------|------|-------------|--|
| XCANPS_DW1R_DB0_M ASK (DW1R_DB0) | 31:24 | rw | x | Data Byte 0 Reads from this field return invalid data if the message has no data. |
| XCANPS_DW1R_DB1_M ASK (DW1R_DB1) | 23:16 | rw | x | Data Byte 1 Reads from this field return invalid data if the message has only 1 byte of data or fewer |

| Field Name | Bits | Type | Reset Value | Description |
|----------------------------------|------|------|-------------|--|
| XCANPS_DW1R_DB2_M ASK (DW1R_DB2) | 15:8 | rw | x | Data Byte 2 Reads from this field return invalid data if the message has only 2 byte of data or fewer |
| XCANPS_DW1R_DB3_M ASK (DW1R_DB3) | 7:0 | rw | x | Data Byte 3 Reads from this field return invalid data if the message has only 3 byte of data or fewer |

Register ([can](#)) XCANPS_RXFIFO_DW2_OFFSET

| | |
|------------------|--------------------------------------|
| Name | XCANPS_RXFIFO_DW2_OFFSET |
| Software Name | RXFIFO_DW2 |
| Relative Address | 0x0000005C |
| Absolute Address | can0: 0xE000805C can1: 0xE000905C |
| Width | 32 bits |
| Access Type | rw |
| Reset Value | x |
| Description | receive message fifo data word 2 |

Register XCANPS_RXFIFO_DW2_OFFSET Details

| Field Name | Bits | Type | Reset Value | Description |
|----------------------------------|-------|------|-------------|--|
| XCANPS_DW2R_DB4_M ASK (DW2R_DB4) | 31:24 | rw | x | Data Byte 4 Reads from this field return invalid data if the message has only 4 byte of data or fewer |
| XCANPS_DW2R_DB5_M ASK (DW2R_DB5) | 23:16 | rw | x | Data Byte 5 Reads from this field return invalid data if the message has only 5 byte of data or fewer |
| XCANPS_DW2R_DB6_M ASK (DW2R_DB6) | 15:8 | rw | x | Data Byte 6 Reads from this field return invalid data if the message has only 6 byte of data or fewer |
| XCANPS_DW2R_DB7_M ASK (DW2R_DB7) | 7:0 | rw | x | Data Byte 7 Reads from this field return invalid data if the message has 7 byte of data or fewer |

Register ([can](#)) XCANPS_AFR_OFFSET

| | |
|------------------|-------------------|
| Name | XCANPS_AFR_OFFSET |
| Software Name | AFR |
| Relative Address | 0x00000060 |

| | |
|------------------|--------------------------------------|
| Absolute Address | can0: 0xE0008060 can1: 0xE0009060 |
| Width | 32 bits |
| Access Type | rw |
| Reset Value | 0x00000000 |
| Description | Acceptance Filter Register |

Register XCANPS_AFR_OFFSET Details

The Acceptance Filter Register (AFR) defines which acceptance filters to use. Each Acceptance Filter ID Register (AFIR) and Acceptance Filter Mask Register (AFMR) pair is associated with a UAF bit.

When the UAF bit is '1,' the corresponding acceptance filter pair is used for acceptance filtering. When the UAF bit is '0,' the corresponding acceptance filter pair is not used for acceptance filtering.

To modify an acceptance filter pair in Normal mode, the corresponding UAF bit in this register must be set to '0.' After the acceptance filter is modified, the corresponding UAF bit must be set to '1.' The following conditions govern the number of UAF bits that can exist in the.

- * If all UAF bits are set to '0,' then all received messages are stored in the RX FIFO
- * If the UAF bits are changed from a '1' to '0' during reception of a CAN message, the message may not be stored in the RX FIFO.

| Field Name | Bits | Type | Reset Value | Description |
|------------------------------------|------|------|-------------|--|
| reserved | 31:4 | rw | 0x0 | reserved |
| XCANPS_AFR_UAF4_M ASK (UAF4) | 3 | rw | 0x0 | Use Acceptance Filter Number 4 Enables the use of acceptance filter pair 4. 1: Indicates Acceptance Filter Mask Register 4 and Acceptance Filter ID Register 4 are used for acceptance filtering. 0: Indicates Acceptance Filter Mask Register 4 and Acceptance Filter ID Register 4 are not used for acceptance filtering. |
| XCANPS_AFR_UAF3_M ASK (UAF3) | 2 | rw | 0x0 | Use Acceptance Filter Number 3 Enables the use of acceptance filter pair 3. 1: Indicates Acceptance Filter Mask Register 3 and Acceptance Filter ID Register 3 are used for acceptance filtering. 0: Indicates Acceptance Filter Mask Register 3 and Acceptance Filter ID Register 3 are not used for acceptance filtering. |

| Field Name | Bits | Type | Reset Value | Description |
|-----------------------------|------|------|-------------|--|
| XCANPS_AFR_UAF2_MASK (UAF2) | 1 | rw | 0x0 | Use Acceptance Filter Number 2. Enables the use of acceptance filter pair 2. 1: Indicates Acceptance Filter Mask Register 2 and Acceptance Filter ID Register 2 are used for acceptance filtering. 0: Indicates Acceptance Filter Mask Register 2 and Acceptance Filter ID Register 2 are not used for acceptance filtering. |
| XCANPS_AFR_UAF1_MASK (UAF1) | 0 | rw | 0x0 | Use Acceptance Filter Number 1. Enables the use of acceptance filter pair 1. 1: Indicates Acceptance Filter Mask Register 1 and Acceptance Filter ID Register 1 are used for acceptance filtering. 0: Indicates Acceptance Filter Mask Register 1 and Acceptance Filter ID Register 1 are not used for acceptance filtering. |

Register ([can](#)) XCANPS_AFMR1_OFFSET

| | |
|------------------|--------------------------------------|
| Name | XCANPS_AFMR1_OFFSET |
| Software Name | AFMR1 |
| Relative Address | 0x00000064 |
| Absolute Address | can0: 0xE0008064 can1: 0xE0009064 |
| Width | 32 bits |
| Access Type | rw |
| Reset Value | x |
| Description | Acceptance Filter Mask Register 1 |

Register XCANPS_AFMR1_OFFSET Details

| Field Name | Bits | Type | Reset Value | Description |
|------------|-------|------|-------------|---|
| AMIDH | 31:21 | rw | x | <p>Standard Message ID Mask</p> <p>These bits are used for masking the Identifier in a Standard Frame.</p> <p>1: Indicates the corresponding bit in Acceptance Mask ID Register is used when comparing the incoming message identifier.</p> <p>0: Indicates the corresponding bit in Acceptance Mask ID Register is not used when comparing the incoming message identifier.</p> |
| AMSRR | 20 | rw | x | <p>Substitute Remote Transmission Request Mask</p> <p>This bit is used for masking the RTR bit in a Standard Frame.</p> <p>1: Indicates the corresponding bit in Acceptance Mask ID Register is used when comparing the incoming message identifier.</p> <p>0: Indicates the corresponding bit in Acceptance Mask ID Register is not used when comparing the incoming message identifier.</p> |
| AMIDE | 19 | rw | x | <p>Identifier Extension Mask</p> <p>Used for masking the IDE bit in CAN frames.</p> <p>1: Indicates the corresponding bit in Acceptance Mask ID Register is used when comparing the incoming message identifier.</p> <p>0: Indicates the corresponding bit in Acceptance Mask ID Register is not used when comparing the incoming message identifier.</p> <p>If AMIDE = 1 and the AIIDE bit in the corresponding Acceptance ID register is 0, this mask is applicable to only Standard frames.</p> <p>If AMIDE = 1 and the AIIDE bit in the corresponding Acceptance ID register is 1, this mask is applicable to only extended frames.</p> <p>If AMIDE = 0 this mask is applicable to both standard and extended frames.</p> |

| Field Name | Bits | Type | Reset Value | Description |
|------------|------|------|-------------|---|
| AMIDL | 18:1 | rw | x | Extended Message ID Mask These bits are used for masking the Identifier in an Extended Frame. 1: Indicates the corresponding bit in Acceptance Mask ID Register is used when comparing the incoming message identifier. 0: Indicates the corresponding bit in Acceptance Mask ID Register is not used when comparing the incoming message identifier. |
| AMRTR | 0 | rw | x | Remote Transmission Request Mask. This bit is used for masking the RTR bit in an Extended Frame. 1: Indicates the corresponding bit in Acceptance Mask ID Register is used when comparing the incoming message identifier. 0: Indicates the corresponding bit in Acceptance Mask ID Register is not used when comparing the incoming message identifier. |

Register ([can](#)) XCANPS_AFIR1_OFFSET

| | |
|------------------|--------------------------------------|
| Name | XCANPS_AFIR1_OFFSET |
| Software Name | AFIR1 |
| Relative Address | 0x00000068 |
| Absolute Address | can0: 0xE0008068 can1: 0xE0009068 |
| Width | 32 bits |
| Access Type | rw |
| Reset Value | x |
| Description | Acceptance Filter ID Register 1 |

Register XCANPS_AFIR1_OFFSET Details

| Field Name | Bits | Type | Reset Value | Description |
|------------|-------|------|-------------|---|
| AIIDH | 31:21 | rw | x | Standard Message ID Standard Identifier |
| AISRR | 20 | rw | x | Substitute Remote Transmission Request Indicates the Remote Transmission Request bit for Standard frames |
| AIIDE | 19 | rw | x | Identifier Extension Differentiates between Standard and Extended frames |

| Field Name | Bits | Type | Reset Value | Description |
|------------|------|------|-------------|---|
| AIIDL | 18:1 | rw | x | Extended Message ID Mask Extended Identifier |
| AIRTR | 0 | rw | x | Remote Transmission Request Mask RTR bit for Extended frames. |

Register ([can](#)) XCANPS_AFMR2_OFFSET

| | |
|------------------|--------------------------------------|
| Name | XCANPS_AFMR2_OFFSET |
| Software Name | AFMR2 |
| Relative Address | 0x0000006C |
| Absolute Address | can0: 0xE000806C can1: 0xE000906C |
| Width | 32 bits |
| Access Type | rw |
| Reset Value | x |
| Description | Acceptance Filter Mask Register 2 |

Register XCANPS_AFMR2_OFFSET Details

| Field Name | Bits | Type | Reset Value | Description |
|------------|-------|------|-------------|--|
| AMIDH | 31:21 | rw | x | Standard Message ID Mask These bits are used for masking the Identifier in a Standard Frame. 1: Indicates the corresponding bit in Acceptance Mask ID Register is used when comparing the incoming message identifier. 0: Indicates the corresponding bit in Acceptance Mask ID Register is not used when comparing the incoming message identifier. |
| AMSRR | 20 | rw | x | Substitute Remote Transmission Request Mask This bit is used for masking the RTR bit in a Standard Frame. 1: Indicates the corresponding bit in Acceptance Mask ID Register is used when comparing the incoming message identifier. 0: Indicates the corresponding bit in Acceptance Mask ID Register is not used when comparing the incoming message identifier. |

| Field Name | Bits | Type | Reset Value | Description |
|------------|------|------|-------------|---|
| AMIDE | 19 | rw | x | <p>Identifier Extension Mask</p> <p>Used for masking the IDE bit in CAN frames.</p> <p>1: Indicates the corresponding bit in Acceptance Mask ID Register is used when comparing the incoming message identifier.</p> <p>0: Indicates the corresponding bit in Acceptance Mask ID Register is not used when comparing the incoming message identifier.</p> <p>If AMIDE = 1 and the AIIDE bit in the corresponding Acceptance ID register is 0, this mask is applicable to only Standard frames.</p> <p>If AMIDE = 1 and the AIIDE bit in the corresponding Acceptance ID register is 1, this mask is applicable to only extended frames.</p> <p>If AMIDE = 0 this mask is applicable to both standard and extended frames.</p> |
| AMIDL | 18:1 | rw | x | <p>Extended Message ID Mask</p> <p>These bits are used for masking the Identifier in an Extended Frame.</p> <p>1: Indicates the corresponding bit in Acceptance Mask ID Register is used when comparing the incoming message identifier.</p> <p>0: Indicates the corresponding bit in Acceptance Mask ID Register is not used when comparing the incoming message identifier.</p> |
| AMRTR | 0 | rw | x | <p>Remote Transmission Request Mask.</p> <p>This bit is used for masking the RTR bit in an Extended Frame.</p> <p>1: Indicates the corresponding bit in Acceptance Mask ID Register is used when comparing the incoming message identifier.</p> <p>0: Indicates the corresponding bit in Acceptance Mask ID Register is not used when comparing the incoming message identifier.</p> |

Register ([can](#)) XCANPS_AFIR2_OFFSET

| | |
|------------------|--------------------------------------|
| Name | XCANPS_AFIR2_OFFSET |
| Software Name | AFIR2 |
| Relative Address | 0x00000070 |
| Absolute Address | can0: 0xE0008070 can1: 0xE0009070 |
| Width | 32 bits |
| Access Type | rw |
| Reset Value | x |
| Description | Acceptance Filter ID Register 2 |

Register XCANPS_AFIR2_OFFSET Details

| Field Name | Bits | Type | Reset Value | Description |
|------------|-------|------|-------------|---|
| AIIDH | 31:21 | rw | x | Standard Message ID Standard Identifier |
| AISRR | 20 | rw | x | Substitute Remote Transmission Request Indicates the Remote Transmission Request bit for Standard frames |
| AIIDE | 19 | rw | x | Identifier Extension Differentiates between Standard and Extended frames |
| AIIDL | 18:1 | rw | x | Extended Message ID Mask Extended Identifier |
| AIRTR | 0 | rw | x | Remote Transmission Request Mask RTR bit for Extended frames. |

Register ([can](#)) XCANPS_AFMR3_OFFSET

| | |
|------------------|--------------------------------------|
| Name | XCANPS_AFMR3_OFFSET |
| Software Name | AFMR3 |
| Relative Address | 0x00000074 |
| Absolute Address | can0: 0xE0008074 can1: 0xE0009074 |
| Width | 32 bits |
| Access Type | rw |
| Reset Value | x |
| Description | Acceptance Filter Mask Register 3 |

Register XCANPS_AFMR3_OFFSET Details

| Field Name | Bits | Type | Reset Value | Description |
|------------|-------|------|-------------|--|
| AMIDH | 31:21 | rw | x | Standard Message ID Mask These bits are used for masking the Identifier in a Standard Frame. 1: Indicates the corresponding bit in Acceptance Mask ID Register is used when comparing the incoming message identifier. 0: Indicates the corresponding bit in Acceptance Mask ID Register is not used when comparing the incoming message identifier. |
| AMSRR | 20 | rw | x | Substitute Remote Transmission Request Mask This bit is used for masking the RTR bit in a Standard Frame. 1: Indicates the corresponding bit in Acceptance Mask ID Register is used when comparing the incoming message identifier. 0: Indicates the corresponding bit in Acceptance Mask ID Register is not used when comparing the incoming message identifier. |
| AMIDE | 19 | rw | x | Identifier Extension Mask Used for masking the IDE bit in CAN frames. 1: Indicates the corresponding bit in Acceptance Mask ID Register is used when comparing the incoming message identifier. 0: Indicates the corresponding bit in Acceptance Mask ID Register is not used when comparing the incoming message identifier. If AMIDE = 1 and the AIIDE bit in the corresponding Acceptance ID register is 0, this mask is applicable to only Standard frames. If AMIDE = 1 and the AIIDE bit in the corresponding Acceptance ID register is 1, this mask is applicable to only extended frames. If AMIDE = 0 this mask is applicable to both standard and extended frames. |

| Field Name | Bits | Type | Reset Value | Description |
|------------|------|------|-------------|---|
| AMIDL | 18:1 | rw | x | Extended Message ID Mask These bits are used for masking the Identifier in an Extended Frame. 1: Indicates the corresponding bit in Acceptance Mask ID Register is used when comparing the incoming message identifier. 0: Indicates the corresponding bit in Acceptance Mask ID Register is not used when comparing the incoming message identifier. |
| AMRTR | 0 | rw | x | Remote Transmission Request Mask. This bit is used for masking the RTR bit in an Extended Frame. 1: Indicates the corresponding bit in Acceptance Mask ID Register is used when comparing the incoming message identifier. 0: Indicates the corresponding bit in Acceptance Mask ID Register is not used when comparing the incoming message identifier. |

Register ([can](#)) XCANPS_AFIR3_OFFSET

| | |
|------------------|--------------------------------------|
| Name | XCANPS_AFIR3_OFFSET |
| Software Name | AFIR3 |
| Relative Address | 0x00000078 |
| Absolute Address | can0: 0xE0008078 can1: 0xE0009078 |
| Width | 32 bits |
| Access Type | rw |
| Reset Value | x |
| Description | Acceptance Filter ID Register 3 |

Register XCANPS_AFIR3_OFFSET Details

| Field Name | Bits | Type | Reset Value | Description |
|------------|-------|------|-------------|---|
| AIIDH | 31:21 | rw | x | Standard Message ID Standard Identifier |
| AISRR | 20 | rw | x | Substitute Remote Transmission Request Indicates the Remote Transmission Request bit for Standard frames |
| AIIDE | 19 | rw | x | Identifier Extension Differentiates between Standard and Extended frames |

| Field Name | Bits | Type | Reset Value | Description |
|------------|------|------|-------------|---|
| AIIDL | 18:1 | rw | x | Extended Message ID Mask Extended Identifier |
| AIRTR | 0 | rw | x | Remote Transmission Request Mask RTR bit for Extended frames. |

Register ([can](#)) XCANPS_AFMR4_OFFSET

| | |
|------------------|--------------------------------------|
| Name | XCANPS_AFMR4_OFFSET |
| Software Name | AFMR4 |
| Relative Address | 0x0000007C |
| Absolute Address | can0: 0xE000807C can1: 0xE000907C |
| Width | 32 bits |
| Access Type | rw |
| Reset Value | x |
| Description | Acceptance Filter Mask Register 4 |

Register XCANPS_AFMR4_OFFSET Details

| Field Name | Bits | Type | Reset Value | Description |
|------------|-------|------|-------------|--|
| AMIDH | 31:21 | rw | x | Standard Message ID Mask These bits are used for masking the Identifier in a Standard Frame. 1: Indicates the corresponding bit in Acceptance Mask ID Register is used when comparing the incoming message identifier. 0: Indicates the corresponding bit in Acceptance Mask ID Register is not used when comparing the incoming message identifier. |
| AMSRR | 20 | rw | x | Substitute Remote Transmission Request Mask This bit is used for masking the RTR bit in a Standard Frame. 1: Indicates the corresponding bit in Acceptance Mask ID Register is used when comparing the incoming message identifier. 0: Indicates the corresponding bit in Acceptance Mask ID Register is not used when comparing the incoming message identifier. |

| Field Name | Bits | Type | Reset Value | Description |
|------------|------|------|-------------|---|
| AMIDE | 19 | rw | x | <p>Identifier Extension Mask</p> <p>Used for masking the IDE bit in CAN frames.</p> <p>1: Indicates the corresponding bit in Acceptance Mask ID Register is used when comparing the incoming message identifier.</p> <p>0: Indicates the corresponding bit in Acceptance Mask ID Register is not used when comparing the incoming message identifier.</p> <p>If AMIDE = 1 and the AIIDE bit in the corresponding Acceptance ID register is 0, this mask is applicable to only Standard frames.</p> <p>If AMIDE = 1 and the AIIDE bit in the corresponding Acceptance ID register is 1, this mask is applicable to only extended frames.</p> <p>If AMIDE = 0 this mask is applicable to both standard and extended frames.</p> |
| AMIDL | 18:1 | rw | x | <p>Extended Message ID Mask</p> <p>These bits are used for masking the Identifier in an Extended Frame.</p> <p>1: Indicates the corresponding bit in Acceptance Mask ID Register is used when comparing the incoming message identifier.</p> <p>0: Indicates the corresponding bit in Acceptance Mask ID Register is not used when comparing the incoming message identifier.</p> |
| AMRTR | 0 | rw | x | <p>Remote Transmission Request Mask.</p> <p>This bit is used for masking the RTR bit in an Extended Frame.</p> <p>1: Indicates the corresponding bit in Acceptance Mask ID Register is used when comparing the incoming message identifier.</p> <p>0: Indicates the corresponding bit in Acceptance Mask ID Register is not used when comparing the incoming message identifier.</p> |

Register ([can](#)) XCANPS_AFIR4_OFFSET

| | |
|------------------|--------------------------------------|
| Name | XCANPS_AFIR4_OFFSET |
| Software Name | AFIR4 |
| Relative Address | 0x00000080 |
| Absolute Address | can0: 0xE0008080 can1: 0xE0009080 |
| Width | 32 bits |
| Access Type | rw |
| Reset Value | x |
| Description | Acceptance Filter ID Register 4 |

Register XCANPS_AFIR4_OFFSET Details

| Field Name | Bits | Type | Reset Value | Description |
|------------|-------|------|-------------|--|
| AIIDH | 31:21 | rw | x | Standard Message ID Standard Identifier |
| AISRR | 20 | rw | x | Substitute Remote Transmission Request Indicates the Remote Transmission Request bit for Standard frames |
| AIIDE | 19 | rw | x | Identifier Extension Differentiates between Standard and Extended frames |
| AIIDL | 18:1 | rw | x | Extended Message ID Mask Extended Identifier |
| AIRTR | 0 | rw | x | Remote Transmission Request Mask RTR bit for Extended frames. |

B.6 DDR Memory Controller (ddrc)

| | |
|--------------|------------------------------|
| Module Name | DDR Memory Controller (ddrc) |
| Base Address | 0xF8006000 ddrc |
| Description | DDR memory controller |
| Vendor Info | Virage Logic/Synopsys |

Register Summary

| Register Name | Address | Width | Type | Reset Value | Description |
|---|------------|-------|-------|-------------|---|
| ddrc_ctrl | 0x00000000 | 32 | rw | 0x00000200 | DDRC Control |
| Two_rank_cfg | 0x00000004 | 29 | rw | 0x000C1076 | Two Rank Configuration |
| HPR_reg | 0x00000008 | 26 | rw | 0x03C0780F | HPR Queue control |
| LPR_reg | 0x0000000C | 26 | rw | 0x03C0780F | LPR Queue control |
| WR_reg | 0x00000010 | 26 | rw | 0x0007F80F | WR Queue control |
| DRAM_param_reg0 | 0x00000014 | 21 | rw | 0x00041016 | DRAM Parameters 0 |
| DRAM_param_reg1 | 0x00000018 | 32 | rw | 0x351B48D9 | DRAM Parameters 1 |
| DRAM_param_reg2 | 0x0000001C | 32 | rw | 0x83015904 | DRAM Parameters 2 |
| DRAM_param_reg3 | 0x00000020 | 32 | mixed | 0x250882D0 | DRAM Parameters 3 |
| DRAM_param_reg4 | 0x00000024 | 28 | mixed | 0x0000003C | DRAM Parameters 4 |
| DRAM_init_param | 0x00000028 | 14 | rw | 0x00002007 | DRAM Initialization Parameters |
| DRAM_EMR_reg | 0x0000002C | 32 | rw | 0x00000008 | DRAM EMR2, EMR3 access |
| DRAM_EMR_MR_reg | 0x00000030 | 32 | rw | 0x00000940 | DRAM EMR, MR access |
| DRAM_burst8_rdwr | 0x00000034 | 29 | mixed | 0x00020034 | DRAM Burst 8 read/write |
| DRAM_disable_DQ | 0x00000038 | 13 | mixed | 0x00000000 | DRAM Disable DQ |
| DRAM_addr_map_bank | 0x0000003C | 20 | rw | 0x00000F77 | Row/Column address bits |
| DRAM_addr_map_col | 0x00000040 | 32 | rw | 0xFFF00000 | Column address bits |
| DRAM_addr_map_row | 0x00000044 | 28 | rw | 0x0FF55555 | Select DRAM row address bits |
| DRAM_ODT_reg | 0x00000048 | 30 | rw | 0x00000249 | DRAM ODT control |
| phy_dbg_reg | 0x0000004C | 20 | ro | 0x00000000 | PHY debug |
| phy_cmd_timeout_rdda ta_cpt | 0x00000050 | 32 | mixed | 0x00010200 | PHY command time out and read data capture FIFO |
| mode_sts_reg | 0x00000054 | 21 | ro | 0x00000000 | Controller operation mode status |
| DLL_calib | 0x00000058 | 17 | rw | 0x00000101 | DLL calibration |
| ODT_delay_hold | 0x0000005C | 16 | rw | 0x00000023 | ODT delay and ODT hold |
| ctrl_reg1 | 0x00000060 | 13 | mixed | 0x0000003E | Controller 1 |

| Register Name | Address | Width | Type | Reset Value | Description |
|--|------------|-------|------------|-------------|--|
| ctrl_reg2 | 0x00000064 | 18 | mixed | 0x00020000 | Controller 2 |
| ctrl_reg3 | 0x00000068 | 26 | rw | 0x00284027 | Controller 3 |
| ctrl_reg4 | 0x0000006C | 16 | rw | 0x00001610 | Controller 4 |
| ctrl_reg5 | 0x00000078 | 32 | mixed | 0x00455111 | Controller register 5 |
| ctrl_reg6 | 0x0000007C | 32 | mixed | 0x00032222 | Controller register 6 |
| CHE_REFRESH_TIMER01 | 0x000000A0 | 24 | rw | 0x00008000 | CHE_REFRESH_TIMER01 |
| CHE_T_ZQ | 0x000000A4 | 32 | rw | 0x10300802 | ZQ parameters |
| CHE_T_ZQ_Short_Interv al_Reg | 0x000000A8 | 28 | rw | 0x0020003A | Misc parameters |
| deep_pwrdown_reg | 0x000000AC | 9 | rw | 0x00000000 | Deep powerdown (LPDDR2) |
| reg_2c | 0x000000B0 | 29 | mixed | 0x00000000 | Training control |
| reg_2d | 0x000000B4 | 11 | rw | 0x00000200 | Misc Debug |
| dfi_timing | 0x000000B8 | 25 | rw | 0x00200067 | DFI timing |
| CHE_ECC_CONTROL_RE G_OFFSET | 0x000000C4 | 2 | rw | 0x00000000 | ECC error clear |
| CHE_CORR_ECC_LOG_R EG_OFFSET | 0x000000C8 | 8 | mixed | 0x00000000 | ECC error correction |
| CHE_CORR_ECC_ADDR REG_OFFSET | 0x000000CC | 31 | ro | 0x00000000 | ECC error correction address log |
| CHE_CORR_ECC_DATA 31_0_REG_OFFSET | 0x000000D0 | 32 | ro | 0x00000000 | ECC error correction data log low |
| CHE_CORR_ECC_DATA 63_32_REG_OFFSET | 0x000000D4 | 32 | ro | 0x00000000 | ECC error correction data log mid |
| CHE_CORR_ECC_DATA 71_64_REG_OFFSET | 0x000000D8 | 8 | ro | 0x00000000 | ECC error correction data log high |
| CHE_UNCORR_ECC_LO G_REG_OFFSET | 0x000000DC | 1 | clon wr | 0x00000000 | ECC unrecoverable error status |
| CHE_UNCORR_ECC_AD DR_REG_OFFSET | 0x000000E0 | 31 | ro | 0x00000000 | ECC unrecoverable error address |
| CHE_UNCORR_ECC_DA TA_31_0_REG_OFFSET | 0x000000E4 | 32 | ro | 0x00000000 | ECC unrecoverable error data low |
| CHE_UNCORR_ECC_DA TA_63_32_REG_OFFSET | 0x000000E8 | 32 | ro | 0x00000000 | ECC unrecoverable error data middle |
| CHE_UNCORR_ECC_DA TA_71_64_REG_OFFSET | 0x000000EC | 8 | ro | 0x00000000 | ECC unrecoverable error data high |
| CHE_ECC_STATS_REG_O FFSET | 0x000000F0 | 16 | clon wr | 0x00000000 | ECC error count |
| ECC_scrub | 0x000000F4 | 4 | rw | 0x00000008 | ECC mode/scrub |
| CHE_ECC_CORR_BIT_M ASK_31_0_REG_OFFSET | 0x000000F8 | 32 | ro | 0x00000000 | ECC data mask low |

| Register Name | Address | Width | Type | Reset Value | Description |
|--|------------|-------|------|-------------|--|
| CHE_ECC_CORR_BIT_MASK_63_32_REG_OFFSET | 0x000000FC | 32 | ro | 0x00000000 | ECC data mask high |
| phy_rcvr_enable | 0x00000114 | 8 | rw | 0x00000000 | Phy receiver enable register |
| PHY_Config0 | 0x00000118 | 31 | rw | 0x40000001 | PHY configuration register for data slice 0. |
| PHY_Config1 | 0x0000011C | 31 | rw | 0x40000001 | PHY configuration register for data slice 1. |
| PHY_Config2 | 0x00000120 | 31 | rw | 0x40000001 | PHY configuration register for data slice 2. |
| PHY_Config3 | 0x00000124 | 31 | rw | 0x40000001 | PHY configuration register for data slice 3. |
| phy_init_ratio0 | 0x0000012C | 20 | rw | 0x00000000 | PHY init ratio register for data slice 0. |
| phy_init_ratio1 | 0x00000130 | 20 | rw | 0x00000000 | PHY init ratio register for data slice 1. |
| phy_init_ratio2 | 0x00000134 | 20 | rw | 0x00000000 | PHY init ratio register for data slice 2. |
| phy_init_ratio3 | 0x00000138 | 20 | rw | 0x00000000 | PHY init ratio register for data slice 3. |
| phy_rd_dqs_cfg0 | 0x00000140 | 20 | rw | 0x00000040 | PHY read DQS configuration register for data slice 0. |
| phy_rd_dqs_cfg1 | 0x00000144 | 20 | rw | 0x00000040 | PHY read DQS configuration register for data slice 1. |
| phy_rd_dqs_cfg2 | 0x00000148 | 20 | rw | 0x00000040 | PHY read DQS configuration register for data slice 2. |
| phy_rd_dqs_cfg3 | 0x0000014C | 20 | rw | 0x00000040 | PHY read DQS configuration register for data slice 3. |
| phy_wr_dqs_cfg0 | 0x00000154 | 20 | rw | 0x00000000 | PHY write DQS configuration register for data slice 0. |
| phy_wr_dqs_cfg1 | 0x00000158 | 20 | rw | 0x00000000 | PHY write DQS configuration register for data slice 1. |
| phy_wr_dqs_cfg2 | 0x0000015C | 20 | rw | 0x00000000 | PHY write DQS configuration register for data slice 2. |
| phy_wr_dqs_cfg3 | 0x00000160 | 20 | rw | 0x00000000 | PHY write DQS configuration register for data slice 3. |
| phy_we_cfg0 | 0x00000168 | 21 | rw | 0x00000040 | PHY FIFO write enable configuration for data slice 0. |
| phy_we_cfg1 | 0x0000016C | 21 | rw | 0x00000040 | PHY FIFO write enable configuration for data slice 1. |
| phy_we_cfg2 | 0x00000170 | 21 | rw | 0x00000040 | PHY FIFO write enable configuration for data slice 2. |
| phy_we_cfg3 | 0x00000174 | 21 | rw | 0x00000040 | PHY FIFO write enable configuration for data slice 3. |

| Register Name | Address | Width | Type | Reset Value | Description |
|---------------------------------------|------------|-------|-------|-------------|---|
| wr_data_slv0 | 0x0000017C | 20 | rw | 0x00000080 | PHY write data slave ratio config for data slice 0. |
| wr_data_slv1 | 0x00000180 | 20 | rw | 0x00000080 | PHY write data slave ratio config for data slice 1. |
| wr_data_slv2 | 0x00000184 | 20 | rw | 0x00000080 | PHY write data slave ratio config for data slice 2. |
| wr_data_slv3 | 0x00000188 | 20 | rw | 0x00000080 | PHY write data slave ratio config for data slice 3. |
| reg_64 | 0x00000190 | 32 | rw | 0x10020000 | Training control 2 |
| reg_65 | 0x00000194 | 20 | rw | 0x00000000 | Training control 3 |
| reg69_6a0 | 0x000001A4 | 29 | ro | 0x00070000 | Training results for data slice 0. |
| reg69_6a1 | 0x000001A8 | 29 | ro | 0x00060200 | Training results for data slice 1. |
| reg6c_6d2 | 0x000001B0 | 28 | ro | 0x00040600 | Training results for data slice 2. |
| reg6c_6d3 | 0x000001B4 | 28 | ro | 0x00000E00 | Training results for data slice 3. |
| reg6e_710 | 0x000001B8 | 30 | ro | x | Training results (2) for data slice 0. |
| reg6e_711 | 0x000001BC | 30 | ro | x | Training results (2) for data slice 1. |
| reg6e_712 | 0x000001C0 | 30 | ro | x | Training results (2) for data slice 2. |
| reg6e_713 | 0x000001C4 | 30 | ro | x | Training results (2) for data slice 3. |
| phy_dll_sts0 | 0x000001CC | 27 | ro | 0x00000000 | Slave DLL results for data slice 0. |
| phy_dll_sts1 | 0x000001D0 | 27 | ro | 0x00000000 | Slave DLL results for data slice 1. |
| phy_dll_sts2 | 0x000001D4 | 27 | ro | 0x00000000 | Slave DLL results for data slice 2. |
| phy_dll_sts3 | 0x000001D8 | 27 | ro | 0x00000000 | Slave DLL results for data slice 3. |
| dll_lock_sts | 0x000001E0 | 24 | ro | 0x00F00000 | DLL Lock Status, read |
| phy_ctrl_sts | 0x000001E4 | 30 | ro | x | PHY Control status, read |
| phy_ctrl_sts_reg2 | 0x000001E8 | 27 | ro | 0x00000013 | PHY Control status (2), read |
| axi_id | 0x00000200 | 26 | ro | 0x00153042 | ID and revision information |
| page_mask | 0x00000204 | 32 | rw | 0x00000000 | Page mask |
| axi_priority_wr_port0 | 0x00000208 | 20 | mixed | 0x000803FF | AXI Priority control for write port 0. |
| axi_priority_wr_port1 | 0x0000020C | 20 | mixed | 0x000803FF | AXI Priority control for write port 1. |
| axi_priority_wr_port2 | 0x00000210 | 20 | mixed | 0x000803FF | AXI Priority control for write port 2. |
| axi_priority_wr_port3 | 0x00000214 | 20 | mixed | 0x000803FF | AXI Priority control for write port 3. |
| axi_priority_rd_port0 | 0x00000218 | 20 | mixed | 0x000003FF | AXI Priority control for read port 0. |

| Register Name | Address | Width | Type | Reset Value | Description |
|---------------------------------------|------------|-------|-------|-------------|--|
| axi_priority_rd_port1 | 0x0000021C | 20 | mixed | 0x000003FF | AXI Priority control for read port 1. |
| axi_priority_rd_port2 | 0x00000220 | 20 | mixed | 0x000003FF | AXI Priority control for read port 2. |
| axi_priority_rd_port3 | 0x00000224 | 20 | mixed | 0x000003FF | AXI Priority control for read port 3. |
| excl_access_cfg0 | 0x00000294 | 18 | rw | 0x00000000 | Exclusive access configuration for port 0. |
| excl_access_cfg1 | 0x00000298 | 18 | rw | 0x00000000 | Exclusive access configuration for port 1. |
| excl_access_cfg2 | 0x0000029C | 18 | rw | 0x00000000 | Exclusive access configuration for port 2. |
| excl_access_cfg3 | 0x000002A0 | 18 | rw | 0x00000000 | Exclusive access configuration for port 3. |
| mode_reg_read | 0x000002A4 | 32 | ro | 0x00000000 | Mode register read data |
| lpddr_ctrl0 | 0x000002A8 | 12 | rw | 0x00000000 | LPDDR2 Control 0 |
| lpddr_ctrl1 | 0x000002AC | 32 | rw | 0x00000000 | LPDDR2 Control 1 |
| lpddr_ctrl2 | 0x000002B0 | 22 | rw | 0x003C0015 | LPDDR2 Control 2 |
| lpddr_ctrl3 | 0x000002B4 | 18 | rw | 0x00000601 | LPDDR2 Control 3 |

Register ([ddrc](#)) [ddrc_ctrl](#)

| | |
|------------------|--------------|
| Name | ddrc_ctrl |
| Relative Address | 0x00000000 |
| Absolute Address | 0xF8006000 |
| Width | 32 bits |
| Access Type | rw |
| Reset Value | 0x00000200 |
| Description | DDRC Control |

Register [ddrc_ctrl](#) Details

| Field Name | Bits | Type | Reset Value | Description |
|---------------------------|-------|------|-------------|---|
| reserved | 31:17 | rw | 0x0 | reserved |
| reg_ddrc_dis_auto_refresh | 16 | rw | 0x0 | Disable auto-refresh. 0: do not disable auto-refresh. 1: disable auto-refresh. Dynamic Bit Field. Note: When this transitions from 0 to 1, any pending refreshes will be immediately scheduled by the controller. |

| Field Name | Bits | Type | Reset Value | Description |
|-------------------------|------|------|-------------|---|
| reg_ddrc_dis_act_bypass | 15 | rw | 0x0 | Only present in designs supporting activate bypass. For Debug only. 0: Do not disable bypass path for high priority read activates. 1: disable bypass path for high priority read activates. |
| reg_ddrc_dis_rd_bypass | 14 | rw | 0x0 | Only present in designs supporting read bypass. For Debug only. 0: Do not disable bypass path for high priority read page hits. 1: disable bypass path for high priority read page hits. |
| reg_ddrc_rdwr_idle_gap | 13:7 | rw | 0x4 | When the preferred transaction store is empty for this many clock cycles, switch to the alternate transaction store if it is non-empty. The read transaction store (both high and low priority) is the default preferred transaction store and the write transaction store is the alternate store. When 'Prefer write over read' is set this is reversed. |
| reg_ddrc_burst8_refresh | 6:4 | rw | 0x0 | Refresh timeout. Programmed value plus one will be the number of refresh timeouts that will be allowed to accumulate before traffic is blocked and the refreshes are forced to execute. Closing pages to perform a refresh is a one-time penalty that must be paid for each group of refreshes; therefore, performing refreshes in a burst reduces the per-refresh penalty of these page closings. Higher numbers for burst_of_N_refresh slightly increases DRAM utilization; lower numbers decreases the worst-case latency associated with refreshes. 0: single refresh 1: burst-of-2 ... 7: burst-of-8 refresh |
| reg_ddrc_data_bus_width | 3:2 | rw | 0x0 | DDR bus width control 00: 32-bit 01: 16-bit 1x: reserved |

| Field Name | Bits | Type | Reset Value | Description |
|-----------------------|------|------|-------------|--|
| reg_ddrc_powerdown_en | 1 | rw | 0x0 | Controller power down control. Update during normal operation. Enable the controller to powerdown after it becomes idle. Dynamic Bit Field. 0: disable 1: enable |
| reg_ddrc_soft_rstb | 0 | rw | 0x0 | Active low soft reset. Update during normal operation. 0: Resets the controller 1: Takes the controller out of reset. Dynamic Bit Field. Note: Software changes DRAM controller register values only when the controller is in the reset state, except for bit fields that can be dynamically updated. |

Register ([ddrc](#)) Two_rank_cfg

| | |
|------------------|------------------------|
| Name | Two_rank_cfg |
| Relative Address | 0x00000004 |
| Absolute Address | 0xF8006004 |
| Width | 29 bits |
| Access Type | rw |
| Reset Value | 0x000C1076 |
| Description | Two Rank Configuration |

Register Two_rank_cfg Details

Most of this register only applies to a dual rank DRAM system

| Field Name | Bits | Type | Reset Value | Description |
|--------------------------|-------|------|-------------|--|
| reserved | 28 | rw | 0x0 | Reserved. Do not modify. |
| reserved | 27 | rw | 0x0 | Reserved. Do not modify. |
| reserved | 26:22 | rw | 0x0 | Reserved. Do not modify. |
| reserved | 21 | rw | 0x0 | Reserved. Do not modify. |
| reserved | 20:19 | rw | 0x1 | Reserved. Do not modify. |
| reg_ddrc_addrmap_cs_bit0 | 18:14 | rw | 0x10 | Must be manually set to 0x0 |
| reserved | 13:12 | rw | 0x1 | Reserved. Do not modify. |
| reg_ddrc_tRFC_nom_x32 | 11:0 | rw | 0x76 | tREFI - Average time between refreshes. Unit: in multiples of 32 clocks. DRAM related. Default value is set for DDR3. Dynamic Bit Field. |

Register ([ddrc](#)) HPR_reg

| | |
|------------------|-------------------|
| Name | HPR_reg |
| Relative Address | 0x00000008 |
| Absolute Address | 0xF8006008 |
| Width | 26 bits |
| Access Type | rw |
| Reset Value | 0x03C0780F |
| Description | HPR Queue control |

Register HPR_reg Details

| Field Name | Bits | Type | Reset Value | Description |
|-----------------------------------|-------|------|-------------|---|
| reg_ddrc_hpr_xact_run_length | 25:22 | rw | 0xF | Number of transactions that will be serviced once the HPR queue goes critical is the smaller of this number and the number of transactions available. |
| reg_ddrc_hpr_max_starve_x32 | 21:11 | rw | 0xF | Number of clocks that the HPR queue can be starved before it goes critical. Unit: 32 clocks |
| reg_ddrc_hpr_min_non_critical_x32 | 10:0 | rw | 0xF | Number of counts that the HPR queue is guaranteed to be non-critical (1 count = 32 DDR clocks). |

Register ([ddrc](#)) LPR_reg

| | |
|------------------|-------------------|
| Name | LPR_reg |
| Relative Address | 0x0000000C |
| Absolute Address | 0xF800600C |
| Width | 26 bits |
| Access Type | rw |
| Reset Value | 0x03C0780F |
| Description | LPR Queue control |

Register LPR_reg Details

| Field Name | Bits | Type | Reset Value | Description |
|-----------------------------------|-------|------|-------------|--|
| reg_ddrc_lpr_xact_run_length | 25:22 | rw | 0xF | Number of transactions that will be serviced once the LPR queue goes critical is the smaller of this number and the number of transactions available |
| reg_ddrc_lpr_max_starve_x32 | 21:11 | rw | 0xF | Number of clocks that the LPR queue can be starved before it goes critical. Unit: 32 clocks |
| reg_ddrc_lpr_min_non_critical_x32 | 10:0 | rw | 0xF | Number of clocks that the LPR queue is guaranteed to be non-critical. Unit: 32 clocks |

Register ([ddrc](#)) WR_reg

| | |
|------------------|------------------|
| Name | WR_reg |
| Relative Address | 0x00000010 |
| Absolute Address | 0xF8006010 |
| Width | 26 bits |
| Access Type | rw |
| Reset Value | 0x0007F80F |
| Description | WR Queue control |

Register WR_reg Details

| Field Name | Bits | Type | Reset Value | Description |
|---------------------------------|-------|------|-------------|---|
| reg_ddrc_w_max_starve_x32 | 25:15 | rw | 0xF | Number of clocks that the Write queue can be starved before it goes critical. Unit: 32 clocks. FOR PERFORMANCE ONLY. |
| reg_ddrc_w_xact_run_length | 14:11 | rw | 0xF | Number of transactions that will be serviced once the WR queue goes critical is the smaller of this number and the number of transactions available |
| reg_ddrc_w_min_non_critical_x32 | 10:0 | rw | 0xF | Number of clock cycles that the WR queue is guaranteed to be non-critical. |

Register ([ddrc](#)) DRAM_param_reg0

| | |
|------------------|-------------------|
| Name | DRAM_param_reg0 |
| Relative Address | 0x00000014 |
| Absolute Address | 0xF8006014 |
| Width | 21 bits |
| Access Type | rw |
| Reset Value | 0x00041016 |
| Description | DRAM Parameters 0 |

Register DRAM_param_reg0 Details

| Field Name | Bits | Type | Reset Value | Description |
|-----------------------------------|-------|------|-------------|--|
| reg_ddrc_post_selfref_g ap_x32 | 20:14 | rw | 0x10 | Minimum time to wait after coming out of self refresh before doing anything. This must be bigger than all the constraints that exist. (spec: Maximum of tXSNR and tXSRD and tXSDLL which is 512 clocks). Unit: in multiples of 32 clocks. DRAM Related |
| reg_ddrc_t_rfc_min | 13:6 | rw | 0x40 | tRFC(min) - Minimum time (units = clk cycles) from refresh to refresh or activate. DRAM Related. Default value is set for DDR3. Dynamic Bit Field. |
| reg_ddrc_t_rc | 5:0 | rw | 0x16 | tRC - Min time between activates to same bank. DRAM Related. Default value is set for DDR3. |

Register ([ddrc](#)) DRAM_param_reg1

| | |
|------------------|-------------------|
| Name | DRAM_param_reg1 |
| Relative Address | 0x00000018 |
| Absolute Address | 0xF8006018 |
| Width | 32 bits |
| Access Type | rw |
| Reset Value | 0x351B48D9 |
| Description | DRAM Parameters 1 |

Register DRAM_param_reg1 Details

| Field Name | Bits | Type | Reset Value | Description |
|--------------------|-------|------|-------------|---|
| reg_ddrc_t_cke | 31:28 | rw | 0x3 | Minimum number of cycles of CKE HIGH/LOW during power down and self refresh. DDR2 and DDR3: Set this to tCKE value. LPDDR2: Set this to the larger of tCKE or tCKESR. Unit: clocks. |
| reg_ddrc_t_ras_min | 26:22 | rw | 0x14 | tRAS(min) - Minimum time between activate and precharge to the same bank. Unit: clocks. DRAM related. Default value is set for DDR3. |

| Field Name | Bits | Type | Reset Value | Description |
|----------------------------|-------|------|-------------|--|
| reg_ddrc_t_ras_max | 21:16 | rw | 0x1B | tRAS(max) - Maximum time between activate and precharge to same bank. Maximum time that a page can be kept open (spec is 70 us). If this is zero then the page is closed after each transaction. Unit: Multiples of 1024 clocks DRAM related. |
| reg_ddrc_t_faw | 15:10 | rw | 0x12 | tFAW - At most 4 banks must be activated in a rolling window of tFAW cycles. Unit: clocks. DRAM Related. |
| reg_ddrc_powerdown_t_o_x32 | 9:5 | rw | 0x6 | After this many clocks of NOP or DESELECT the controller will put the DRAM into power down. This must be enabled in the Master Control Register. Unit: Multiples of 32 clocks. |
| reg_ddrc_wr2pre | 4:0 | rw | 0x19 | Minimum time between write and precharge to same bank DDR and DDR3: WL + BL/2 + tWR LPDDR2: WL + BL/2 + tWR + 1 Unit: Clocks Where, WL: write latency. BL: burst length. This must match the value programmed in the BL bit of the mode register to the DRAM. BST is not supported at present. tWR: write recovery time. This comes directly from the DRAM specs. |

Register ([ddrc](#)) DRAM_param_reg2

| | |
|------------------|-------------------|
| Name | DRAM_param_reg2 |
| Relative Address | 0x0000001C |
| Absolute Address | 0xF800601C |
| Width | 32 bits |
| Access Type | rw |
| Reset Value | 0x83015904 |
| Description | DRAM Parameters 2 |

Register DRAM_param_reg2 Details

| Field Name | Bits | Type | Reset Value | Description |
|-----------------|-------|------|-------------|--|
| reg_ddrc_t_rcd | 31:28 | rw | 0x8 | tRCD - AL Minimum time from activate to read or write command to same bank. Min value for this is 1. AL = Additive Latency. DRAM Related. |
| reg_ddrc_rd2pre | 27:23 | rw | 0x6 | Minimum time from read to precharge of same bank DDR2: $AL + BL/2 + \max(tRTP, 2) - 2$ DDR3: $AL + \max(tRTP, 4)$ LPDDR2: $BL/2 + tRTP - 1$ AL: Additive Latency; BL: DRAM Burst Length; tRTP: value from spec. DRAM related. |
| reg_ddrc_pad_pd | 22:20 | rw | 0x0 | If pads have a power-saving mode, this is the greater of the time for the pads to enter power down or the time for the pads to exit power down. Used only in non-DFI designs. Unit: clocks. |
| reg_ddrc_t_xp | 19:15 | rw | 0x2 | tXP: Minimum time after power down exit to any operation. DRAM related. |
| reg_ddrc_wr2rd | 14:10 | rw | 0x16 | Minimum time from write command to read command. Includes time for bus turnaround and recovery times and all per-bank, per-rank, and global constraints. DDR2 and DDR3: $WL + tWTR + BL/2$ LPDDR2: $WL + tWTR + BL/2 + 1$ Unit: clocks. Where, WL: Write latency. BL: burst length. This must match the value programmed in the BL bit of the mode register to the DRAM. tWTR: internal WRITE to READ command delay. This comes directly from the DRAM specs. |

| Field Name | Bits | Type | Reset Value | Description |
|------------------------|------|------|-------------|--|
| reg_ddrc_rd2wr | 9:5 | rw | 0x8 | Minimum time from read command to write command. Include time for bus turnaround and all per-bank, per-rank, and global constraints. DDR2 and DDR3: $RL + BL/2 + 2 - WL$ LPDDR2: $RL + BL/2 + RU (tDQSCKmax / tCK) + 1 - WL$ Write Pre-amble and DQ/DQS jitter timer is included in the above equation. DRAM RELATED. |
| reg_ddrc_write_latency | 4:0 | rw | 0x4 | Time from write command to write data on DDRC to PHY Interface. (PHY adds an extra flop delay on the write data path; hence this value is one less than the write latency of the DRAM device itself). DDR2 and DDR3: $WL - 1$ LPDDR2: WL Where, WL: Write Latency of DRAM DRAM related. In non-LPDDR mode, the minimum DRAM Write Latency (DDR2) supported is 3. In LPDDR mode, the required DRAM Write Latency of 1 is supported. Since write latency (CWL) min is 3, and DDR2 CWL is CL-1, the min (DDR2) CL supported is 4 |

Register (ddrc) DRAM_param_reg3

| | |
|------------------|-------------------|
| Name | DRAM_param_reg3 |
| Relative Address | 0x00000020 |
| Absolute Address | 0xF8006020 |
| Width | 32 bits |
| Access Type | mixed |
| Reset Value | 0x250882D0 |
| Description | DRAM Parameters 3 |

Register DRAM_param_reg3 Details

| Field Name | Bits | Type | Reset Value | Description |
|-----------------------|------|------|-------------|--|
| reserved | 31 | rw | 0x0 | Reserved. Do not modify. |
| reg_ddrc_dis_pad_pd | 30 | rw | 0x0 | 1: disable the pad power down feature 0: Enable the pad power down feature. |
| reg_phy_mode_ddr1_dr2 | 29 | rw | 0x1 | unused |

| Field Name | Bits | Type | Reset Value | Description |
|----------------------------------|-------|------|-------------|--|
| reg_ddrc_read_latency | 28:24 | rw | 0x5 | Non-LPDDR2: not used. DDR2 and DDR3: Set to Read Latency, RL. Time from Read command to Read data on DRAM interface. It is used to calculate when DRAM clock may be stopped. Unit: DDR clock. |
| reg_ddrc_en_dfi_dram_clk_disable | 23 | rw | 0x0 | Enables the assertion of ddrcc_dfi_dram_clk_disable. In DDR2/DDR3, only asserted in Self Refresh. In mDDR/LPDDR2, can be asserted in following: - during normal operation (Clock Stop), - in Power Down - in Self Refresh - In Deep Power Down |
| reg_ddrc_mobile | 22 | rw | 0x0 | 0: DDR2 or DDR3 device. 1: LPDDR2 device. |
| reg_ddrc_sdram | 21 | rw | 0x0 | Must be set = 0. |
| reg_ddrc_refresh_to_x32 | 20:16 | rw | 0x8 | If the refresh timer (tRFC_nom, as known as tREFI) has expired at least once, but it has not expired burst_of_N_refresh times yet, then a 'speculative refresh' may be performed. A speculative refresh is a refresh performed at a time when refresh would be useful, but before it is absolutely required. When the DRAM bus is idle for a period of time determined by this refresh idle timeout and the refresh timer has expired at least once since the last refresh, then a 'speculative refresh' will be performed. Speculative refreshes will continue successively until there are no refreshes pending or until new reads or writes are issued to the controller. Dynamic Bit Field. |
| reg_ddrc_t_rp | 15:12 | rw | 0x8 | tRP - Minimum time from precharge to activate of same bank. DRAM RELATED |
| reg_ddrc_refresh_margin | 11:8 | rw | 0x2 | Issue critical refresh or page close this many cycles before the critical refresh or page timer expires. It is recommended that this not be changed from the default value. |
| reg_ddrc_t_rrd | 7:5 | rw | 0x6 | tRRD - Minimum time between activates from bank A to bank B. (spec: 10ns or less) DRAM RELATED |
| reg_ddrc_t_ccd | 4:2 | rw | 0x4 | tCCD - Minimum time between two reads or two writes (from bank a to bank b). DRAM related. |
| reserved | 1:0 | ro | 0x0 | Reserved |

Register (ddrc) DRAM_param_reg4

| | |
|------------------|-------------------|
| Name | DRAM_param_reg4 |
| Relative Address | 0x00000024 |
| Absolute Address | 0xF8006024 |
| Width | 28 bits |
| Access Type | mixed |
| Reset Value | 0x0000003C |
| Description | DRAM Parameters 4 |

Register DRAM_param_reg4 Details

| Field Name | Bits | Type | Reset Value | Description |
|-----------------------------|------|--------|-------------|---|
| reg_ddrc_mr_rdata_vali d | 27 | clrond | 0x0 | This bit indicates whether the Mode Register Read Data present at address 0xA9 is valid or not. This bit is 0 by default. This bit will be cleared (0), whenever a Mode Register Read command is issued. This bit will be set to 1, when the Mode Register Read Data is written to register 0xA9. |
| reg_ddrc_mr_type | 26 | rw | 0x0 | Indicates whether the Mode register operation is read or write 0: write 1: read |
| ddrc_reg_mr_wr_busy | 25 | ro | 0x0 | Core must initiate a MR write / read operation only if this signal is low. This signal goes high in the clock after the controller accepts the write / read request. It goes low when (i) MR write command has been issued to the DRAM (ii) MR Read data has been returned to Controller. Any MR write / read command that is received when 'ddrc_reg_mr_wr_busy' is high is not accepted. 0: Indicates that the core can initiate a mode register write / read operation. 1: Indicates that mode register write / read operation is in progress. |
| reg_ddrc_mr_data | 24:9 | rw | 0x0 | DDR2 and DDR3: Mode register write data. LPDDR2: The 16 bits are interpreted for reads and writes: Reads: MR Addr[7:0], Don't Care[7:0]. Writes: MR Addr[7:0], MR Data[7:0]. |
| reg_ddrc_mr_addr | 8:7 | rw | 0x0 | DDR2 and DDR3: Mode register address. LPDDR2: not used. 00: MR0 01: MR1 10: MR2 11: MR3 |

| Field Name | Bits | Type | Reset Value | Description |
|----------------------------|------|------|-------------|--|
| reg_ddrc_mr_wr | 6 | wo | 0x0 | A low to high signal on this signal will do a mode register write or read. Controller will accept this command, if this signal is detected high and "ddrc_reg_mr_wr_busy" is detected low. |
| reserved | 5:2 | rw | 0xF | Reserved. Do not modify. |
| reg_ddrc_prefer_write | 1 | rw | 0x0 | 0: Bank selector prefers reads over writes 1: Bank selector prefers writes over reads |
| reg_ddrc_en_2t_timing_mode | 0 | rw | 0x0 | 1: DDRC will use 2T timing 0: DDRC will use 1T timing |

Register ([ddrc](#)) DRAM_init_param

| | |
|------------------|--------------------------------|
| Name | DRAM_init_param |
| Relative Address | 0x00000028 |
| Absolute Address | 0xF8006028 |
| Width | 14 bits |
| Access Type | rw |
| Reset Value | 0x00002007 |
| Description | DRAM Initialization Parameters |

Register DRAM_init_param Details

| Field Name | Bits | Type | Reset Value | Description |
|-------------------------|-------|------|-------------|---|
| reg_ddrc_t_mrd | 13:11 | rw | 0x4 | tMRD - Cycles between Load Mode commands. DRAM related. Default value is set for DDR3. |
| reg_ddrc_pre_ocd_x32 | 10:7 | rw | 0x0 | Wait period before driving the 'OCD Complete' command to DRAM. Units are in counts of a global timer that pulses every 32 clock cycles. There is no known spec requirement for this. It may be set to zero. |
| reg_ddrc_final_wait_x32 | 6:0 | rw | 0x7 | Cycles to wait after completing the DRAM init sequence before starting the dynamic scheduler. Units are in counts of a global timer that pulses every 32 clock cycles. Default value is set for DDR3. |

Register ([ddrc](#)) DRAM_EMR_reg

| | |
|------------------|--------------|
| Name | DRAM_EMR_reg |
| Relative Address | 0x0000002C |
| Absolute Address | 0xF800602C |
| Width | 32 bits |

Access Type rw
 Reset Value 0x00000008
 Description DRAM EMR2, EMR3 access

Register DRAM_EMR_reg Details

| Field Name | Bits | Type | Reset Value | Description |
|---------------|-------|------|-------------|--|
| reg_ddrc_emr3 | 31:16 | rw | 0x0 | DDR2: Value loaded into EMR3 register DDR3: Value loaded into MR3 register. Set Bit[2:0] to 3'b000. These bits are set appropriately by the Controller during Read Data eye training and Read DQS gate leveling. LPDDR2: Unused |
| reg_ddrc_emr2 | 15:0 | rw | 0x8 | DDR2: Value loaded into EMR2 register DDR3: Value loaded into MR2 register LPDDR2: Value loaded into MR3 register |

Register ([ddrc](#)) DRAM_EMR_MR_reg

Name DRAM_EMR_MR_reg
 Relative Address 0x00000030
 Absolute Address 0xF8006030
 Width 32 bits
 Access Type rw
 Reset Value 0x00000940
 Description DRAM EMR, MR access

Register DRAM_EMR_MR_reg Details

| Field Name | Bits | Type | Reset Value | Description |
|--------------|-------|------|-------------|---|
| reg_ddrc_emr | 31:16 | rw | 0x0 | DDR2: Value loaded into EMR1 register. (Bits[9:7] are for OCD and the setting in this reg is ignored. Controller sets this bits appropriately during initialization DDR3: Value loaded into MR1 register. Set Bit[7] to 0. This bit is set appropriately by the Controller during Write Leveling LPDDR2: Value loaded into MR2 register |
| reg_ddrc_mr | 15:0 | rw | 0x940 | DDR2: Value loaded into MR register. (Bit[8] is for DLL and the setting here is ignored. Controller sets this bit appropriately DDR3: Value loaded into MR0 register. LPDDR2: Value loaded into MR1 register |

Register ([ddrc](#)) DRAM_burst8_rdwr

| | |
|------------------|-------------------------|
| Name | DRAM_burst8_rdwr |
| Relative Address | 0x00000034 |
| Absolute Address | 0xF8006034 |
| Width | 29 bits |
| Access Type | mixed |
| Reset Value | 0x00020034 |
| Description | DRAM Burst 8 read/write |

Register DRAM_burst8_rdwr Details

| Field Name | Bits | Type | Reset Value | Description |
|-------------------------|-------|------|-------------|---|
| reg_ddrc_burstchop | 28 | rw | 0x0 | Feature not supported. When 1, Controller is out in burstchop mode. |
| reserved | 27:26 | ro | 0x0 | Reserved |
| reg_ddrc_post_cke_x1024 | 25:16 | rw | 0x2 | Clock cycles to wait after driving CKE high to start the DRAM initialization sequence. Units: 1024 clocks. DDR2 typically require a 400 ns delay, requiring this value to be programmed to 2 at all clock speeds. LPDDR2 - Typically require this to be programmed for a delay of 200 us. |
| reserved | 15:14 | ro | 0x0 | Reserved |

| Field Name | Bits | Type | Reset Value | Description |
|------------------------|------|------|-------------|---|
| reg_ddrc_pre_cke_x1024 | 13:4 | rw | 0x3 | Clock cycles to wait after a DDR software reset before driving CKE high to start the DRAM initialization sequence. Units: 1024 clock cycles. DDR2 Specifications typically require this to be programmed for a delay of >= 200 uS. LPDDR2 - tINIT0 of 20 mS (max) + tINIT1 of 100 nS (min) |
| reg_ddrc_burst_rdwr | 3:0 | rw | 0x4 | Controls the burst size used to access the DRAM. This must match the BL mode register setting in the DRAM. 0010: Burst length of 4 0100: Burst length of 8 1000: Burst length of 16 (LPDDR2 with 16-bit data) All other values are reserved |

Register ([ddrc](#)) DRAM_disable_DQ

| | |
|------------------|-----------------|
| Name | DRAM_disable_DQ |
| Relative Address | 0x00000038 |
| Absolute Address | 0xF8006038 |
| Width | 13 bits |
| Access Type | mixed |
| Reset Value | 0x00000000 |
| Description | DRAM Disable DQ |

Register DRAM_disable_DQ Details

| Field Name | Bits | Type | Reset Value | Description |
|------------|------|------|-------------|--------------------------|
| reserved | 12:9 | rw | 0x0 | Reserved. Do not modify. |
| reserved | 8 | rw | 0x0 | Reserved. Do not modify. |
| reserved | 7 | rw | 0x0 | Reserved. Do not modify. |
| reserved | 6 | rw | 0x0 | Reserved. Do not modify. |
| reserved | 5:2 | ro | 0x0 | Reserved |

| Field Name | Bits | Type | Reset Value | Description |
|--------------------------|------|------|-------------|--|
| reg_ddrc_dis_dq | 1 | rw | 0x0 | When 1, DDRC will not de-queue any transactions from the CAM. Bypass will also be disabled. All transactions will be queued in the CAM. This is for debug only; no reads or writes are issued to DRAM as long as this is asserted. Dynamic Bit Field. |
| reg_ddrc_force_low_pri_n | 0 | rw | 0x0 | Read Transaction Priority disable. 0: read transactions forced to low priority (turns off Bypass). 1: HPR reads allowed if enabled in the AXI priority read registers. |

Register ([ddrc](#)) DRAM_addr_map_bank

| | |
|------------------|-------------------------|
| Name | DRAM_addr_map_bank |
| Relative Address | 0x0000003C |
| Absolute Address | 0xF800603C |
| Width | 20 bits |
| Access Type | rw |
| Reset Value | 0x00000F77 |
| Description | Row/Column address bits |

Register DRAM_addr_map_bank Details

Note: address bits are relative to a byte address. For example, the value 0x777 in bits[11:0] selects byte address bits [14:12] as bank address bits.

| Field Name | Bits | Type | Reset Value | Description |
|-------------------------|-------|------|-------------|---|
| reg_ddrc_addrmap_col_b6 | 19:16 | rw | 0x0 | Full bus width mode: Selects the address bits used as column address bits 7. Half bus width mode: Selects the address bits used as column address bits 8. Valid range is 0-7. Internal Base 9. The selected address bit for each of the column address bits is determined by adding the Internal Base to the value of this field. |
| reg_ddrc_addrmap_col_b5 | 15:12 | rw | 0x0 | Full bus width mode: Selects the address bits used as column address bits 6. Half bus width mode: Selects the address bits used as column address bits 7. Valid range is 0-7. Internal Base 8. The selected address bit for each of the column address bits is determined by adding the Internal Base to the value of this field. |

| Field Name | Bits | Type | Reset Value | Description |
|--------------------------|------|------|-------------|---|
| reg_ddrc_addrmap_bank_b2 | 11:8 | rw | 0xF | Selects the AXI address bit used as bank address bit 2. Valid range 0 to 14, and 15. Internal Base: 7. The selected address bit is determined by adding the Internal Base to the value of this field. If set to 15, bank address bit 2 is set to 0. |
| reg_ddrc_addrmap_bank_b1 | 7:4 | rw | 0x7 | Selects the address bits used as bank address bit 1. Valid Range: 0 to 14; Internal Base: 6. The selected address bit for each of the bank address bits is determined by adding the Internal Base to the value of this field. |
| reg_ddrc_addrmap_bank_b0 | 3:0 | rw | 0x7 | Selects the address bits used as bank address bit 0. Valid Range: 0 to 14. Internal Base: 5. The selected address bit for each of the bank address bits is determined by adding the Internal Base to the value of this field. |

Register ([ddrc](#)) DRAM_addr_map_col

| | |
|------------------|---------------------|
| Name | DRAM_addr_map_col |
| Relative Address | 0x00000040 |
| Absolute Address | 0xF8006040 |
| Width | 32 bits |
| Access Type | rw |
| Reset Value | 0xFFF00000 |
| Description | Column address bits |

Register DRAM_addr_map_col Details

Selects the address bits used as DRAM column address bits

| Field Name | Bits | Type | Reset Value | Description |
|--------------------------|-------|------|-------------|--|
| reg_ddrc_addrmap_col_b11 | 31:28 | rw | 0xF | <p>Full bus width mode: Selects the address bit used as column address bit 13. (Column address bit 12 in LPDDR2 mode)</p> <p>Half bus width mode: Unused. To make it unused, this should be set to 15. (Column address bit 13 in LPDDR2 mode)</p> <p>Valid Range: 0 to 7, and 15.</p> <p>Internal Base: 14.</p> <p>The selected address bit is determined by adding the Internal Base to the value of this field. If set to 15, this column address bit is set to 0. Note: Per JEDEC DDR2 spec, column address bit 10 is reserved for indicating auto-precharge, and hence no source address bit can be mapped to column address bit 10. In LPDDR2, there is a dedicated bit for auto-precharge in the CA bus, and hence column bit 10 is used.</p> |
| reg_ddrc_addrmap_col_b10 | 27:24 | rw | 0xF | <p>Full bus width mode: Selects the address bit used as column address bit 12. (Column address bit 11 in LPDDR2 mode)</p> <p>Half bus width mode: Selects the address bit used as column address bit 13. (Column address bit 12 in LPDDR2 mode) Valid Range: 0 to 7, and 15.</p> <p>Internal Base: 13</p> <p>The selected address bit is determined by adding the Internal Base to the value of this field. If set to 15, this column address bit is set to 0. Note: Per JEDEC DDR2 spec, column address bit 10 is reserved for indicating auto-precharge, and hence no source address bit can be mapped to column address bit 10. In LPDDR2, there is a dedicated bit for auto-precharge in the CA bus, and hence column bit 10 is used.</p> |
| reg_ddrc_addrmap_col_b9 | 23:20 | rw | 0xF | <p>Full bus width mode: Selects the address bit used as column address bit 11. (Column address bit 10 in LPDDR2 mode)</p> <p>Half bus width mode: Selects the address bit used as column address bit 12. (Column address bit 11 in LPDDR2 mode)</p> <p>Valid Range: 0 to 7, and 15</p> <p>Internal Base: 12</p> <p>The selected address bit is determined by adding the Internal Base to the value of this field. If set to 15, this column address bit is set to 0.</p> <p>Note: Per JEDEC DDR2 spec, column address bit 10 is reserved for indicating auto-precharge, and hence no source address bit can be mapped to column address bit 10. In LPDDR2, there is a dedicated bit for auto-precharge in the CA bus, and hence column bit 10 is used.</p> |

| Field Name | Bits | Type | Reset Value | Description |
|-------------------------|-------|------|-------------|---|
| reg_ddrc_addrmap_col_b8 | 19:16 | rw | 0x0 | <p>Full bus width mode: Selects the address bit used as column address bit 9.</p> <p>Half bus width mode: Selects the address bit used as column address bit 11. (Column address bit 10 in LPDDR2 mode)</p> <p>Valid Range: 0 to 7, and 15</p> <p>Internal Base: 11</p> <p>The selected address bit is determined by adding the Internal Base to the value of this field. If set to 15, this column address bit is set to 0.</p> <p>Note: Per JEDEC spec, column address bit 10 is reserved for indicating auto-precharge, and hence no source address bit can be mapped to column address bit 10. In LPDDR2, there is a dedicated bit for auto-precharge in the CA bus, and hence column bit 10 is used.</p> |
| reg_ddrc_addrmap_col_b7 | 15:12 | rw | 0x0 | <p>Full bus width mode: Selects the address bit used as column address bit 8.</p> <p>Half bus width mode: Selects the address bit used as column address bit 9.</p> <p>Valid Range: 0 to 7, and 15.</p> <p>Internal Base: 10.</p> <p>The selected address bit is determined by adding the Internal Base to the value of this field. If set to 15, this column address bit is set to 0.</p> <p>Note: Per JEDEC spec, column address bit 10 is reserved for indicating auto-precharge, and hence no source address bit can be mapped to column address bit 10. In LPDDR2, there is a dedicated bit for auto-precharge in the CA bus, and hence column bit 10 is used.</p> |
| reg_ddrc_addrmap_col_b4 | 11:8 | rw | 0x0 | <p>Full bus width mode: Selects the address bit used as column address bit 5.</p> <p>Half bus width mode: Selects the address bit used as column address bit 6. Valid Range: 0 to 7.</p> <p>Internal Base: 7.</p> <p>The selected address bit for each of the column address bits is determined by adding the Internal Base to the value of this field.</p> |

| Field Name | Bits | Type | Reset Value | Description |
|-------------------------|------|------|-------------|---|
| reg_ddrc_addrmap_col_b3 | 7:4 | rw | 0x0 | Full bus width mode: Selects the address bit used as column address bit 4. Half bus width mode: Selects the address bit used as column address bit 5. Valid Range: 0 to 7 Internal Base: 6 The selected address bit is determined by adding the Internal Base to the value of this field. |
| reg_ddrc_addrmap_col_b2 | 3:0 | rw | 0x0 | Full bus width mode: Selects the address bit used as column address bit 3. Half bus width mode: Selects the address bit used as column address bit 4. Valid Range: 0 to 7. Internal Base: 5 The selected address bit is determined by adding the Internal Base to the value of this field. |

Register (ddrc) DRAM_addr_map_row

| | |
|------------------|------------------------------|
| Name | DRAM_addr_map_row |
| Relative Address | 0x00000044 |
| Absolute Address | 0xF8006044 |
| Width | 28 bits |
| Access Type | rw |
| Reset Value | 0xFF55555 |
| Description | Select DRAM row address bits |

Register DRAM_addr_map_row Details

| Field Name | Bits | Type | Reset Value | Description |
|--------------------------|-------|------|-------------|---|
| reg_ddrc_addrmap_row_b15 | 27:24 | rw | 0xF | Selects the AXI address bit used as row address bit 15. Valid Range: 0 to 5, Internal Base: 24 The selected address bit is determined by adding the Internal Base to the value of this field. If set to 15, row address bit 15 is set to 0. |
| reg_ddrc_addrmap_row_b14 | 23:20 | rw | 0xF | Selects the AXI address bit used as row address bit 14. Valid Range: 0 to 6, Internal Base: 23 The selected address bit is determined by adding the Internal Base to the value of this field. If set to 15, row address bit 14 is set to 0. |
| reg_ddrc_addrmap_row_b13 | 19:16 | rw | 0x5 | Selects the AXI address bit used as row address bit 13. Valid Range: 0 to 7, Internal Base: 22 The selected address bit is determined by adding the Internal Base to the value of this field. If set to 15, row address bit 13 is set to 0. |

| Field Name | Bits | Type | Reset Value | Description |
|----------------------------|-------|------|-------------|---|
| reg_ddrc_addrmap_row_b12 | 15:12 | rw | 0x5 | Selects the AXI address bit used as row address bit 12. Valid Range: 0 to 8, Internal Base: 21 The selected address bit is determined by adding the Internal Base to the value of this field. If set to 15, row address bit 12 is set to 0. |
| reg_ddrc_addrmap_row_b2_11 | 11:8 | rw | 0x5 | Selects the AXI address bits used as row address bits 2 to 11. Valid Range: 0 to 11. Internal Base: 11 (for row address bit 2) to 20 (for row address bit 11) The selected address bit for each of the row address bits is determined by adding the Internal Base to the value of this field. |
| reg_ddrc_addrmap_row_b1 | 7:4 | rw | 0x5 | Selects the AXI address bits used as row address bit 1. Valid Range: 0 to 11. Internal Base: 10 The selected address bit for each of the row address bits is determined by adding the Internal Base to the value of this field. |
| reg_ddrc_addrmap_row_b0 | 3:0 | rw | 0x5 | Selects the AXI address bits used as row address bit 0. Valid Range: 0 to 11. Internal Base: 9 The selected address bit for each of the row address bits is determined by adding the Internal Base to the value of this field |

Note: address bits are relative to a byte address. For example, the value 0x0FFF6666 selects byte address bits [29:15] as row address bits in a 32-bit bus width configuration.

Register (ddrc) DRAM_ODT_reg

| | |
|------------------|------------------|
| Name | DRAM_ODT_reg |
| Relative Address | 0x00000048 |
| Absolute Address | 0xF8006048 |
| Width | 30 bits |
| Access Type | rw |
| Reset Value | 0x00000249 |
| Description | DRAM ODT control |

Register DRAM_ODT_reg Details

Parts of this register are unused.

| Field Name | Bits | Type | Reset Value | Description |
|------------|-------|------|-------------|--------------------------|
| reserved | 29:27 | rw | 0x0 | Reserved. Do not modify. |
| reserved | 26:24 | rw | 0x0 | Reserved. Do not modify. |
| reserved | 23:21 | rw | 0x0 | Reserved. Do not modify. |
| reserved | 20:18 | rw | 0x0 | Reserved. Do not modify. |

| Field Name | Bits | Type | Reset Value | Description |
|------------------------|-------|------|-------------|--|
| reg_phy_idle_local_odt | 17:16 | rw | 0x0 | Value to drive on the 2-bit local_odt PHY outputs when output enable is not asserted and a read is not in progress. Typically this is the value required to disable termination to save power when idle. |
| reg_phy_wr_local_odt | 15:14 | rw | 0x0 | Value to drive on the 2-bit local_odt PHY outputs when write levelling is enabled for DQS. |
| reg_phy_rd_local_odt | 13:12 | rw | 0x0 | Value to drive on the 2-bit local_odt PHY outputs when output enable is not asserted and a read is in progress (where 'in progress' is defined as after a read command is issued and until all read data has been returned all the way to the controller.) Typically this is set to the value required to enable termination at the desired strength for read usage. |
| reserved | 11:9 | rw | 0x1 | Reserved. Do not modify. |
| reserved | 8:6 | rw | 0x1 | Reserved. Do not modify. |
| reg_ddrc_rank0_wr_odt | 5:3 | rw | 0x1 | [1:0] - Indicates which remote ODT's must be turned on during a write to rank 0. Each of the 2 ranks has a remote ODT (in the DRAM) which can be turned on by setting the appropriate bit here. Rank 0 is controlled by the LSB; Rank 1 is controlled by bit next to the LSB. For each rank, set its bit to 1 to enable its ODT. [2]: If 1 then local ODT is enabled during writes to rank 0. |
| reg_ddrc_rank0_rd_odt | 2:0 | rw | 0x1 | Unused. [1:0] - Indicates which remote ODTs must be turned ON during a read to rank 0. Each of the 2 ranks has a remote ODT (in the DRAM) which can be turned on by setting the appropriate bit here. Rank 0 is controlled by the LSB; Rank 1 is controlled by bit next to the LSB. For each rank, set its bit to 1 to enable its ODT. [2]: If 1 then local ODT is enabled during reads to rank 0. |

Register ([ddrc](#)) phy_dbg_reg

| | |
|------------------|-------------|
| Name | phy_dbg_reg |
| Relative Address | 0x0000004C |
| Absolute Address | 0xF800604C |
| Width | 20 bits |
| Access Type | ro |
| Reset Value | 0x00000000 |
| Description | PHY debug |

Register phy_dbg_reg Details

| Field Name | Bits | Type | Reset Value | Description |
|------------------------------|------|------|-------------|--|
| phy_reg_bc_fifo_re3 | 19 | ro | 0x0 | Debug read capture FIFO read enable for data slice 3. |
| phy_reg_bc_fifo_we3 | 18 | ro | 0x0 | Debug read capture FIFO write enable, for data slice 3. |
| phy_reg_bc_dqs_oe3 | 17 | ro | 0x0 | Debug DQS output enable for data slice 3. |
| phy_reg_bc_dq_oe3 | 16 | ro | 0x0 | Debug DQ output enable for data slice 3. |
| phy_reg_bc_fifo_re2 | 15 | ro | 0x0 | Debug read capture FIFO read enable for data slice 2. |
| phy_reg_bc_fifo_we2 | 14 | ro | 0x0 | Debug read capture FIFO write enable, for data slice 2. |
| phy_reg_bc_dqs_oe2 | 13 | ro | 0x0 | Debug DQS output enable for data slice 2. |
| phy_reg_bc_dq_oe2 | 12 | ro | 0x0 | Debug DQ output enable for data slice 2. |
| phy_reg_bc_fifo_re1 | 11 | ro | 0x0 | Debug read capture FIFO read enable for data slice 1. |
| phy_reg_bc_fifo_we1 | 10 | ro | 0x0 | Debug read capture FIFO write enable, for data slice 1. |
| phy_reg_bc_dqs_oe1 | 9 | ro | 0x0 | Debug DQS output enable for data slice 1. |
| phy_reg_bc_dq_oe1 | 8 | ro | 0x0 | Debug DQ output enable for data slice 1. |
| phy_reg_bc_fifo_re0 | 7 | ro | 0x0 | Debug read capture FIFO read enable for data slice 0. |
| phy_reg_bc_fifo_we0 | 6 | ro | 0x0 | Debug read capture FIFO write enable, for data slice 0. |
| phy_reg_bc_dqs_oe0 | 5 | ro | 0x0 | Debug DQS output enable for data slice 0. |
| phy_reg_bc_dq_oe0 | 4 | ro | 0x0 | Debug DQ output enable for data slice 0. |
| phy_reg_rdc_fifo_rst_err_cnt | 3:0 | ro | 0x0 | Counter for counting how many times the pointers of read capture FIFO differ when they are reset by dll_calib. |

Register ([ddrc](#)) phy_cmd_timeout_rddata_cpt

| | |
|------------------|---|
| Name | phy_cmd_timeout_rddata_cpt |
| Relative Address | 0x00000050 |
| Absolute Address | 0xF8006050 |
| Width | 32 bits |
| Access Type | mixed |
| Reset Value | 0x00010200 |
| Description | PHY command time out and read data capture FIFO |

Register phy_cmd_timeout_rddata_cpt Details

| Field Name | Bits | Type | Reset Value | Description |
|------------------------------------|-------|------|-------------|--|
| reg_phy_wrlvl_num_of_dq0 | 31:28 | rw | 0x0 | This register value determines the number of samples used for each ratio increment during Write Leveling. Num_of_iteration = reg_phy_wrlvl_num_of_dq0 + 1 The recommended value for this register is 8. Accuracy is better with higher value, but this will cause leveling to run longer. |
| reg_phy_gatelvl_num_of_dq0 | 27:24 | rw | 0x0 | This register value determines register determines the number of samples used for each ratio increment during Gate Training. Num_of_iteration = reg_phy_gatelvl_num_of_dq0 + 1 The recommended value for this register is 8. Accuracy is better with higher value, but this will cause leveling to run longer. |
| reserved | 23:20 | ro | 0x0 | Reserved |
| reg_phy_clk_stall_level | 19 | rw | 0x0 | 1: stall clock, for DLL aging control |
| reg_phy_dis_phy_ctrl_resetn | 18 | rw | 0x0 | Disable the reset from Phy Ctrl macro. 1: PHY Ctrl macro reset port is always HIGH 0: PHY Ctrl macro gets power on reset. |
| reg_phy_rdc_fifo_reset_err_cnt_clr | 17 | rw | 0x0 | Clear/reset for counter rdc_fifo_reset_err_cnt[3:0]. 0: no clear 1: clear Note: This is a synchronous dynamic signal that must have timing closed. |
| reg_phy_use_fixed_read_enable | 16 | rw | 0x1 | When 1: PHY generates FIFO read enable after fixed number of clock cycles as defined by reg_phy_rdc_we_to_re_delay[3:0]. When 0: PHY uses the not_empty method to do the read enable generation. Note: This port must be set HIGH during training/leveling process i.e. when ddr_c_dfi_wrlvl_en/ ddr_c_dfi_rdlvl_en/ ddr_c_dfi_rdlvl_gate_en port is set HIGH. |
| reg_phy_rdc_fifo_reset_disable | 15 | rw | 0x0 | When 1, disable counting the number of times the Read Data Capture FIFO has been reset when the FIFO was not empty. |
| reserved | 14:12 | ro | 0x0 | Reserved |

| Field Name | Bits | Type | Reset Value | Description |
|----------------------------|------|------|-------------|---|
| reg_phy_rdc_we_to_re_delay | 11:8 | rw | 0x2 | This register value + 1 give the number of clock cycles between writing into the Read Capture FIFO and the read operation. The setting of this register determines the read data timing and depends upon total delay in the system for read operation which include fly-by delays, trace delay, clkout_invert etc. This is used only if reg_phy_use_fixed_re=1. |
| reg_phy_wr_cmd_to_data | 7:4 | rw | 0x0 | Not used in DFI PHY. |
| reg_phy_rd_cmd_to_data | 3:0 | rw | 0x0 | Not used in DFI PHY. |

Register (ddrc) mode_sts_reg

| | |
|------------------|----------------------------------|
| Name | mode_sts_reg |
| Relative Address | 0x00000054 |
| Absolute Address | 0xF8006054 |
| Width | 21 bits |
| Access Type | ro |
| Reset Value | 0x00000000 |
| Description | Controller operation mode status |

Register mode_sts_reg Details

| Field Name | Bits | Type | Reset Value | Description |
|-------------------------|-------|------|-------------|--|
| ddrc_reg_dbg_hpr_qdepth | 20:16 | ro | 0x0 | Indicates the number of entries currently in the High Priority Read (HPR) CAM. |
| ddrc_reg_dbg_lpr_qdepth | 15:10 | ro | 0x0 | Indicates the number of entries currently in the Low Priority Read (LPR) CAM. |
| ddrc_reg_dbg_wr_qdepth | 9:4 | ro | 0x0 | Indicates the number of entries currently in the Write CAM. |
| ddrc_reg_dbg_stall | 3 | ro | 0x0 | 0: commands are being accepted. 1: no commands are accepted by the controller. |
| ddrc_reg_operating_mode | 2:0 | ro | 0x0 | Gives the status of the controller. 0: DDRC Init 1: Normal operation 2: Powerdown mode 3: Self-refresh mode 4 and above: deep power down mode (LPDDR2 only) |

Register ([ddrc](#)) DLL_calib

| | |
|------------------|-----------------|
| Name | DLL_calib |
| Relative Address | 0x00000058 |
| Absolute Address | 0xF8006058 |
| Width | 17 bits |
| Access Type | rw |
| Reset Value | 0x00000101 |
| Description | DLL calibration |

Register DLL_calib Details

| Field Name | Bits | Type | Reset Value | Description |
|------------------------|------|------|-------------|---|
| reg_ddrc_dis_dll_calib | 16 | rw | 0x0 | When 1, disable dll_calib generated by the controller. The core should issue the dll_calib signal using co_gs_dll_calib input. This input is changeable on the fly. When 0, controller will issue dll_calib periodically |
| reserved | 15:8 | rw | 0x1 | Reserved. Do not modify. |
| reserved | 7:0 | rw | 0x1 | Reserved. Do not modify. |

Register ([ddrc](#)) ODT_delay_hold

| | |
|------------------|------------------------|
| Name | ODT_delay_hold |
| Relative Address | 0x0000005C |
| Absolute Address | 0xF800605C |
| Width | 16 bits |
| Access Type | rw |
| Reset Value | 0x00000023 |
| Description | ODT delay and ODT hold |

Register ODT_delay_hold Details

| Field Name | Bits | Type | Reset Value | Description |
|----------------------|-------|------|-------------|--|
| reg_ddrc_wr_odt_hold | 15:12 | rw | 0x0 | Cycles to hold ODT for a Write Command. When 0x0, ODT signal is ON for 1 cycle. When 0x1, it is ON for 2 cycles, etc. The values to program in different modes are : DRAM Burst of 4 -2: 4-2 => 2 DRAM Burst of 8 -4: 8-4 => 4 |
| reg_ddrc_rd_odt_hold | 11:8 | rw | 0x0 | Unused |

| Field Name | Bits | Type | Reset Value | Description |
|-----------------------|------|------|-------------|--|
| reg_ddrc_wr_odt_delay | 7:4 | rw | 0x2 | The delay, in clock cycles, from issuing a write command to setting ODT values associated with that command. ODT setting should remain constant for the entire time that DQS is driven by the controller. The suggested value for DDR2 is WL - 5 and for DDR3 is 0. WL is Write latency. DDR2 ODT has a 2-cycle on-time delay and a 2.5-cycle off-time delay. ODT is not applicable to LPDDR2. |
| reg_ddrc_rd_odt_delay | 3:0 | rw | 0x3 | UNUSED |

Register ([ddrc](#)) ctrl_reg1

| | |
|------------------|--------------|
| Name | ctrl_reg1 |
| Relative Address | 0x00000060 |
| Absolute Address | 0xF8006060 |
| Width | 13 bits |
| Access Type | mixed |
| Reset Value | 0x0000003E |
| Description | Controller 1 |

Register ctrl_reg1 Details

| Field Name | Bits | Type | Reset Value | Description |
|---------------------------------|------|------|-------------|--|
| reg_ddrc_selfref_en | 12 | rw | 0x0 | If 1, then the controller will put the DRAM into self refresh when the transaction store is empty. Dynamic Bit Field. |
| reserved | 11 | ro | 0x0 | Always keep this set to 0x0 |
| reg_ddrc_dis_collision_page_opt | 10 | rw | 0x0 | When this is set to 0, auto-precharge will be disabled for the flushed command in a collision case. Collision cases are write followed by read to same address, read followed by write to same address, or write followed by write to same address with DIS_WC bit = 1 (where 'same address' comparisons exclude the two address bits representing critical word). |
| reg_ddrc_dis_wc | 9 | rw | 0x0 | Disable Write Combine: 0: enable 1: disable |
| reg_ddrc_refresh_update_level | 8 | rw | 0x0 | Toggle this signal to indicate that refresh register(s) have been updated. The value will be automatically updated when exiting soft reset. So it does not need to be toggled initially. Dynamic Bit Field. |

| Field Name | Bits | Type | Reset Value | Description |
|--------------------------|------|------|-------------|--|
| reg_ddrc_auto_pre_en | 7 | rw | 0x0 | When set, most reads and writes will be issued with auto-precharge. (Exceptions can be made for collision cases.) |
| reg_ddrc_lpr_num_entries | 6:1 | rw | 0x1F | Number of entries in the low priority transaction store is this value plus 1. In this design, by default all read ports are treated as low priority and hence the value of 0x1F. The hpr_num_entries is 32 minus this value. Bit [6] is ignored. |
| reg_ddrc_pageclose | 0 | rw | 0x0 | If true, bank will be closed and kept closed if no transactions are available for it. If false, bank will remain open until there is a need to close it (to open a different page, or for page timeout or refresh timeout.) This does not apply when auto-refresh is used. |

Register ([ddrc](#)) ctrl_reg2

| | |
|------------------|--------------|
| Name | ctrl_reg2 |
| Relative Address | 0x00000064 |
| Absolute Address | 0xF8006064 |
| Width | 18 bits |
| Access Type | mixed |
| Reset Value | 0x00020000 |
| Description | Controller 2 |

Register ctrl_reg2 Details

| Field Name | Bits | Type | Reset Value | Description |
|---------------------------------|-------|------|-------------|---|
| reg_arb_go2critical_en | 17 | rw | 0x1 | 0: Keep reg_ddrc_go2critical_wr and reg_ddrc_go2critical_rd signals going to DDRC at 0. 1: Set reg_ddrc_go2critical_wr and reg_ddrc_go2critical_rd signals going to DDRC based on Urgent input coming from AXI master. |
| reserved | 16:13 | ro | 0x0 | Reserved |
| reg_ddrc_go2critical_hysteresis | 12:5 | rw | 0x0 | Describes the number of cycles that co_gs_go2critical_rd or co_gs_go2critical_wr must be asserted before the corresponding queue moves to the 'critical' state in the DDRC. The arbiter controls the co_gs_go2critical_* signals; it is designed for use with this hysteresis field set to 0. |
| reserved | 4:0 | ro | 0x0 | Reserved |

Register ([ddrc](#)) ctrl_reg3

| | |
|------------------|--------------|
| Name | ctrl_reg3 |
| Relative Address | 0x00000068 |
| Absolute Address | 0xF8006068 |
| Width | 26 bits |
| Access Type | rw |
| Reset Value | 0x00284027 |
| Description | Controller 3 |

Register ctrl_reg3 Details

| Field Name | Bits | Type | Reset Value | Description |
|-----------------------|-------|------|-------------|--|
| reg_ddrc_dfi_t_wlmsrd | 25:16 | rw | 0x28 | DDR2 and LPDDR2: not applicable. DDR3: First DQS/DQS# rising edge after write leveling mode is programmed. This is same as the tMLRD value from the DRAM spec. |
| reg_ddrc_rdlvl_rr | 15:8 | rw | 0x40 | DDR2 and LPDDR2: not applicable. DDR3: Read leveling read-to-read delay. Specifies the minimum number of clock cycles from the assertion of a read command to the next read command. Only applicable when connecting to PHYs operating in PHY RdLvl Evaluation mode. |
| reg_ddrc_wrlvl_ww | 7:0 | rw | 0x27 | DDR2: not applicable. LPDDR2 and DDR3: Write leveling write-to-write delay. Specifies the minimum number of clock cycles from the assertion of a ddr_c_dfi_wrlvl_strobe signal to the next ddr_c_dfi_wrlvl_strobe signal. Only applicable when connecting to PHYs operating in PHY RdLvl Evaluation mode. Recommended value is: (RL + reg_phy_rdc_we_to_re_delay + 50) |

Register ([ddrc](#)) ctrl_reg4

| | |
|------------------|--------------|
| Name | ctrl_reg4 |
| Relative Address | 0x0000006C |
| Absolute Address | 0xF800606C |
| Width | 16 bits |
| Access Type | rw |
| Reset Value | 0x00001610 |
| Description | Controller 4 |

Register ctrl_reg4 Details

| Field Name | Bits | Type | Reset Value | Description |
|----------------------------------|------|------|-------------|---|
| dfi_t_ctrlupd_interval_max_x1024 | 15:8 | rw | 0x16 | This is the maximum amount of time between Controller initiated DFI update requests. This timer resets with each update request; when the timer expires, traffic is blocked for a few cycles. PHY can use this idle time to recalibrate the delay lines to the DLLs. The DLL calibration is also used to reset PHY FIFO pointers in case of data capture errors. Updates are required to maintain calibration over PVT, but frequent updates may impact performance. Units: 1024 clocks |
| dfi_t_ctrlupd_interval_min_x1024 | 7:0 | rw | 0x10 | This is the minimum amount of time between Controller initiated DFI update requests (which will be executed whenever the controller is idle). Set this number higher to reduce the frequency of update requests, which can have a small impact on the latency of the first read request when the controller is idle. Units: 1024 clocks |

Register ([ddrc](#)) ctrl_reg5

| | |
|------------------|-----------------------|
| Name | ctrl_reg5 |
| Relative Address | 0x00000078 |
| Absolute Address | 0xF8006078 |
| Width | 32 bits |
| Access Type | mixed |
| Reset Value | 0x00455111 |
| Description | Controller register 5 |

Register ctrl_reg5 Details

| Field Name | Bits | Type | Reset Value | Description |
|----------------|-------|------|-------------|--|
| reserved | 31:26 | ro | 0x0 | Reserved |
| reg_ddrc_t_cke | 25:20 | rw | 0x4 | Minimum CKE low width for Self Refresh entry to exit Timing in memory clock cycles. Recommended settings: LPDDR2: tCKESR DDR2: tCKE DDR3: tCKE+1 |

| Field Name | Bits | Type | Reset Value | Description |
|---------------------------------|-------|------|-------------|--|
| reg_ddrc_t_cksrx | 19:16 | rw | 0x5 | This is the time before Self Refresh Exit that CK is maintained as a valid clock before issuing SRX. Specifies the clock stable time before SRX. Recommended settings: LPDDR2: 2 DDR2: 1 DDR3: tCKSRX |
| reg_ddrc_t_cksre | 15:12 | rw | 0x5 | This is the time after Self Refresh Entry that CK is maintained as a valid clock. Specifies the clock disable delay after SRE. Recommended settings: LPDDR2: 2 DDR2: 1 DDR3: tCKSRE |
| reg_ddrc_dfi_t_dram_clk_enable | 11:8 | rw | 0x1 | Specifies the number of DFI clock cycles from the de-assertion of the ddrc_dfi_dram_clk_disable signal on the DFI until the first valid rising edge of the clock to the DRAM memory devices at the PHY-DRAM boundary. If the DFI clock and the memory clock are not phase aligned, this timing parameter should be rounded up to the next integer value. |
| reg_ddrc_dfi_t_dram_clk_disable | 7:4 | rw | 0x1 | Specifies the number of DFI clock cycles from the assertion of the ddrc_dfi_dram_clk_disable signal on the DFI until the clock to the DRAM memory devices, at the PHY-DRAM boundary, maintains a low value. If the DFI clock and the memory clock are not phase aligned, this timing parameter should be rounded up to the next integer value. |
| reg_ddrc_dfi_t_ctrl_delay | 3:0 | rw | 0x1 | Specifies the number of DFI clock cycles after an assertion or deassertion of the DFI control signals that the control signals at the PHY-DRAM interface reflect the assertion or de-assertion. If the DFI clock and the memory clock are not phase-aligned, this timing parameter should be rounded up to the next integer value. |

Register ([ddrc](#)) ctrl_reg6

| | |
|------------------|-----------------------|
| Name | ctrl_reg6 |
| Relative Address | 0x0000007C |
| Absolute Address | 0xF800607C |
| Width | 32 bits |
| Access Type | mixed |
| Reset Value | 0x00032222 |
| Description | Controller register 6 |

Register ctrl_reg6 Details

| Field Name | Bits | Type | Reset Value | Description |
|-------------------|-------|------|-------------|---|
| reserved | 31:20 | ro | 0x0 | Reserved |
| reg_ddrc_t_ckcsx | 19:16 | rw | 0x3 | This is the time before Clock Stop Exit that CK is maintained as a valid clock before issuing DPD _X . Specifies the clock stable time before next command after Clock Stop Exit. Recommended setting for LPDDR2: t _{XP} + 2. |
| reg_ddrc_t_ckdpdx | 15:12 | rw | 0x2 | This is the time before Deep Power Down Exit that CK is maintained as a valid clock before issuing DPD _X . Specifies the clock stable time before DPD _X . Recommended setting for LPDDR2: 2. |
| reg_ddrc_t_ckdpde | 11:8 | rw | 0x2 | This is the time after Deep Power Down Entry that CK is maintained as a valid clock. Specifies the clock disable delay after DPDE. Recommended setting for LPDDR2: 2. |
| reg_ddrc_t_ckpdx | 7:4 | rw | 0x2 | This is the time before Power Down Exit that CK is maintained as a valid clock before issuing PDX. Specifies the clock stable time before PDX. Recommended setting for LPDDR2: 2. |
| reg_ddrc_t_ckpde | 3:0 | rw | 0x2 | This is the time after Power Down Entry that CK is maintained as a valid clock. Specifies the clock disable delay after PDE. Recommended setting for LPDDR2: 2. |

Register ([ddrc](#)) CHE_REFRESH_TIMER01

| | |
|------------------|---------------------|
| Name | CHE_REFRESH_TIMER01 |
| Relative Address | 0x000000A0 |
| Absolute Address | 0xF80060A0 |
| Width | 24 bits |
| Access Type | rw |
| Reset Value | 0x00008000 |
| Description | CHE_REFRESH_TIMER01 |

Register CHE_REFRESH_TIMER01 Details

| Field Name | Bits | Type | Reset Value | Description |
|------------|-------|------|-------------|--------------------------|
| reserved | 23:12 | rw | 0x8 | Reserved. Do not modify. |
| reserved | 11:0 | rw | 0x0 | Reserved. Do not modify. |

Register ([ddrc](#)) CHE_T_ZQ

| | |
|------------------|---------------|
| Name | CHE_T_ZQ |
| Relative Address | 0x000000A4 |
| Absolute Address | 0xF80060A4 |
| Width | 32 bits |
| Access Type | rw |
| Reset Value | 0x10300802 |
| Description | ZQ parameters |

Register CHE_T_ZQ Details

| Field Name | Bits | Type | Reset Value | Description |
|-----------------------------|-------|------|-------------|--|
| reg_ddrc_t_zq_short_no p | 31:22 | rw | 0x40 | DDR2: not applicable. LPDDR2 and DDR3: Number of cycles of NOP required after a ZQCS (ZQ calibration short) command is issued to DRAM. Units: Clock cycles. |
| reg_ddrc_t_zq_long_no p | 21:12 | rw | 0x300 | DDR2: not applicable. LPDDR2 and DDR3: Number of cycles of NOP required after a ZQCL (ZQ calibration long) command is issued to DRAM. Units: Clock cycles. |
| reg_ddrc_t_mod | 11:2 | rw | 0x200 | Mode register set command update delay (minimum d'128) |
| reg_ddrc_ddr3 | 1 | rw | 0x1 | Indicates operating in DDR2/DDR3 mode. Default value is set for DDR3. |
| reg_ddrc_dis_auto_zq | 0 | rw | 0x0 | 1=disable controller generation of ZQCS command. Co_gs_zq_calib_short can be used instead to control ZQ calibration commands. 0=internally generate ZQCS commands based on reg_ddrc_t_zq_short_interval_x1024. This is only present for implementations supporting DDR3 and LPDDR2 devices. |

Register ([ddrc](#)) CHE_T_ZQ_Short_Interval_Reg

| | |
|------------------|-----------------------------|
| Name | CHE_T_ZQ_Short_Interval_Reg |
| Relative Address | 0x000000A8 |
| Absolute Address | 0xF80060A8 |
| Width | 28 bits |
| Access Type | rw |
| Reset Value | 0x0020003A |
| Description | Misc parameters |

Register CHE_T_ZQ_Short_Interval_Reg Details

| Field Name | Bits | Type | Reset Value | Description |
|---------------------------|-------|------|-------------|---|
| dram_rstn_x1024 | 27:20 | rw | 0x2 | Number of cycles to assert DRAM reset signal during init sequence. Units: 1024 Clock cycles. Applicable for DDR3 only. |
| t_zq_short_interval_x1024 | 19:0 | rw | 0x3A | DDR2: not used. LPDDR2 and DDR3: Average interval to wait between automatically issuing ZQCS (ZQ calibration short) commands to DDR3 devices. Meaningless if reg_ddrc_dis_auto_zq=1. Units: 1024 Clock cycles. |

Register ([ddrc](#)) deep_pwrdown_reg

| | |
|------------------|-------------------------|
| Name | deep_pwrdown_reg |
| Relative Address | 0x000000AC |
| Absolute Address | 0xF80060AC |
| Width | 9 bits |
| Access Type | rw |
| Reset Value | 0x00000000 |
| Description | Deep powerdown (LPDDR2) |

Register deep_pwrdown_reg Details

| Field Name | Bits | Type | Reset Value | Description |
|------------------------|------|------|-------------|---|
| deeppowerdown_to_x1024 | 8:1 | rw | 0x0 | DDR2 and DDR3: not used. LPDDR2: Minimum deep power down time. DDR exits from deep power down mode immediately after reg_ddrc_deeppowerdown_en is deasserted. Value from the spec is 500us. Units are in 1024 clock cycles. For performance only. |
| deeppowerdown_en | 0 | rw | 0x0 | DDR2 and DDR3: not used. LPDDR2: 0: Brings Controller out of Deep Powerdown mode. 1: Puts DRAM into Deep Powerdown mode when the transaction store is empty. For performance only. Dynamic Bit Field. |

Register ([ddrc](#)) reg_2c

| | |
|------|--------|
| Name | reg_2c |
|------|--------|

| | |
|------------------|------------------|
| Relative Address | 0x000000B0 |
| Absolute Address | 0xF80060B0 |
| Width | 29 bits |
| Access Type | mixed |
| Reset Value | 0x00000000 |
| Description | Training control |

Register reg_2c Details

| Field Name | Bits | Type | Reset Value | Description |
|--------------------------------|------|--------|-------------|--|
| reg_ddrc_dfi_rd_data_eye_train | 28 | rw | 0x0 | DDR2: not applicable. LPDDR2 and DDR3: 0: Read Data Eye training is disabled 1: Read Data Eye training mode has been enabled as part of init sequence. |
| reg_ddrc_dfi_rd_dqs_gate_level | 27 | rw | 0x0 | 0: Read DQS gate leveling is disabled. 1: Read DQS Gate Leveling mode has been enabled as part of init sequence; Valid only for DDR3 DFI designs |
| reg_ddrc_dfi_wr_level_en | 26 | rw | 0x0 | 0: Write leveling disabled. 1: Write leveling mode has been enabled as part of init sequence; Valid only for DDR3 DFI designs |
| ddrc_reg_trdlvl_max_error | 25 | clonwr | 0x0 | DDR2: not applicable. LPDDR2 and DDR3: When '1' indicates that the reg_ddrc_dfi_rdrlvl_max_x1024 timer has timed out. This is a Clear-on-Write register. If read leveling or gate training timed out, an error is indicated by the DDRC and this bit gets set. The value is held at that value until it is cleared. Clearing is done by writing a '0' to this register. |
| ddrc_reg_twr lvl_max_error | 24 | clonwr | 0x0 | When '1' indicates that the reg_ddrc_dfi_wrlvl_max_x1024 timer has timed out. This is a Clear-on-Write register. If write leveling timed out, an error is indicated by the DDRC and this bit gets set. The value is held until it is cleared. Clearing is done by writing a '0' to this register. Only present in designs that support DDR3. |

| Field Name | Bits | Type | Reset Value | Description |
|---------------------|-------|------|-------------|--|
| dfi_rdlvl_max_x1024 | 23:12 | rw | 0x0 | Read leveling maximum time. Specifies the maximum number of clock cycles that the controller will wait for a response (phy_dfi_rdlvl_resp) to a read leveling enable signal (ddrc_dfi_rdlvl_en or ddr_c_dfi_rdlvl_gate_en). Only applicable when connecting to PHY's operating in 'PHY RdLvl Evaluation' mode. Typical value 0xFFF Units 1024 clocks |
| dfi_wrlvl_max_x1024 | 11:0 | rw | 0x0 | Write leveling maximum time. Specifies the maximum number of clock cycles that the controller will wait for a response (phy_dfi_wrlvl_resp) to a write leveling enable signal (ddrc_dfi_wrlvl_en). Only applicable when connecting to PHY's operating in 'PHY WrLvl Evaluation' mode. Typical value 0xFFF Units 1024 clocks |

Register ([ddrc](#)) reg_2d

| | |
|------------------|------------|
| Name | reg_2d |
| Relative Address | 0x000000B4 |
| Absolute Address | 0xF80060B4 |
| Width | 11 bits |
| Access Type | rw |
| Reset Value | 0x00000200 |
| Description | Misc Debug |

Register reg_2d Details

| Field Name | Bits | Type | Reset Value | Description |
|-------------------|------|------|-------------|--|
| reserved | 10 | rw | 0x0 | Reserved. Do not modify. |
| reg_ddrc_skip_ocd | 9 | rw | 0x1 | This register must be kept at 1'b1. 1'b0 is NOT supported. 1: Indicates the controller to skip OCD adjustment step during DDR2 initialization. OCD_Default and OCD_Exit are performed instead. 0: Not supported. |
| reserved | 8:0 | rw | 0x0 | Reserved. Do not modify. |

Register ([ddrc](#)) dfi_timing

| | |
|------------------|------------|
| Name | dfi_timing |
| Relative Address | 0x000000B8 |

Absolute Address 0xF80060B8
 Width 25 bits
 Access Type rw
 Reset Value 0x00200067
 Description DFI timing

Register dfi_timing Details

| Field Name | Bits | Type | Reset Value | Description |
|---------------------------|-------|------|-------------|---|
| reg_ddrc_dfi_t_ctrlup_max | 24:15 | rw | 0x40 | Specifies the maximum number of clock cycles that the ddrc_dfi_ctrlupd_req signal can assert. |
| reg_ddrc_dfi_t_ctrlup_min | 14:5 | rw | 0x3 | Specifies the minimum number of clock cycles that the ddrc_dfi_ctrlupd_req signal must be asserted. |
| reg_ddrc_dfi_t_rddata_en | 4:0 | rw | 0x7 | Time from the assertion of a READ command on the DFI interface to the assertion of the phy_dfi_rddata_en signal. DDR2 and DDR3: RL - 1 LPDDR: RL Where RL is read latency of DRAM. |

Register (ddrc) CHE_ECC_CONTROL_REG_OFFSET

Name CHE_ECC_CONTROL_REG_OFFSET
 Relative Address 0x000000C4
 Absolute Address 0xF80060C4
 Width 2 bits
 Access Type rw
 Reset Value 0x00000000
 Description ECC error clear

Register CHE_ECC_CONTROL_REG_OFFSET Details

| Field Name | Bits | Type | Reset Value | Description |
|------------------------------------|------|------|-------------|---|
| Clear_Correctable_DRAM_ECC_error | 1 | rw | 0x0 | Writing 1 to this bit will clear the correctable log valid bit and the correctable error counters. Write 0 to this bit will start capturing incoming correctable error count. |
| Clear_Uncorrectable_DRAM_ECC_error | 0 | rw | 0x0 | Writing 1 to this bit will clear the uncorrectable log valid bit and the uncorrectable error counters. Write 0 to this bit will start capturing incoming uncorrectable error count. |

Register ([ddrc](#)) CHE_CORR_ECC_LOG_REG_OFFSET

| | |
|------------------|-----------------------------|
| Name | CHE_CORR_ECC_LOG_REG_OFFSET |
| Relative Address | 0x000000C8 |
| Absolute Address | 0xF80060C8 |
| Width | 8 bits |
| Access Type | mixed |
| Reset Value | 0x00000000 |
| Description | ECC error correction |

Register CHE_CORR_ECC_LOG_REG_OFFSET Details

| Field Name | Bits | Type | Reset Value | Description |
|-----------------------|------|------------|-------------|---|
| ECC_CORRECTED_BIT_NUM | 7:1 | clon wr | 0x0 | Indicator of the bit number syndrome in error for single-bit errors. The field is 7-bit wide to handle 72-bits of data. There are only 13-valid bits going to an ECC lane (8-data + 5-ECC). Only 4-bits are needed to encode a max value of d'13. Bit[7] of this register is used to indicate the exact byte lane. When an error happens, if CORR_ECC_LOG_COL[0] from register 0xF80060CC is 1'b0, then the error happened in Lane 0 or 1. If CORR_ECC_LOG_COL[0] is 1'b1, then the error happened in Lane 2 or 3. Bit[7] of this register indicates whether the error is from upper or lower byte lane. If it is 0, then it is lower byte lane and if it is 1, then it is upper byte lane. Together with CORR_ECC_LOG_COL[0] and bit[7] of this register, the exact byte lane with correctable error can be determined. |
| CORR_ECC_LOG_VALID | 0 | ro | 0x0 | Set to 1 when a correctable ECC error is captured. As long as this is 1 no further ECC errors will be captured. This is cleared when a 1 is written to register bit[1] of ECC control register, 0xF80060C4. |

Register ([ddrc](#)) CHE_CORR_ECC_ADDR_REG_OFFSET

| | |
|------------------|----------------------------------|
| Name | CHE_CORR_ECC_ADDR_REG_OFFSET |
| Relative Address | 0x000000CC |
| Absolute Address | 0xF80060CC |
| Width | 31 bits |
| Access Type | ro |
| Reset Value | 0x00000000 |
| Description | ECC error correction address log |

Register CHE_CORR_ECC_ADDR_REG_OFFSET Details

| Field Name | Bits | Type | Reset Value | Description |
|-------------------|-------|------|-------------|---------------|
| CORR_ECC_LOG_BANK | 30:28 | ro | 0x0 | Bank [2:0] |
| CORR_ECC_LOG_ROW | 27:12 | ro | 0x0 | Row [15:0] |
| CORR_ECC_LOG_COL | 11:0 | ro | 0x0 | Column [11:0] |

Register ([ddrc](#)) CHE_CORR_ECC_DATA_31_0_REG_OFFSET

Name CHE_CORR_ECC_DATA_31_0_REG_OFFSET
 Relative Address 0x000000D0
 Absolute Address 0xF80060D0
 Width 32 bits
 Access Type ro
 Reset Value 0x00000000
 Description ECC error correction data log low

Register CHE_CORR_ECC_DATA_31_0_REG_OFFSET Details

| Field Name | Bits | Type | Reset Value | Description |
|-----------------------|------|------|-------------|--|
| CORR_ECC_LOG_DAT_31_0 | 31:0 | ro | 0x0 | Bits [31:0] of the data that caused the captured correctable ECC error. (Data associated with the first ECC error if multiple errors occurred since CORR_ECC_LOG_VALID was cleared). Since each ECC engine handles 8-bits of data, only the lower 8-bits of this register have valid data. The upper 24-bits will always be 0. |

Register ([ddrc](#)) CHE_CORR_ECC_DATA_63_32_REG_OFFSET

Name CHE_CORR_ECC_DATA_63_32_REG_OFFSET
 Relative Address 0x000000D4
 Absolute Address 0xF80060D4
 Width 32 bits
 Access Type ro
 Reset Value 0x00000000
 Description ECC error correction data log mid

Register CHE_CORR_ECC_DATA_63_32_REG_OFFSET Details

| Field Name | Bits | Type | Reset Value | Description |
|------------------------|------|------|-------------|---|
| CORR_ECC_LOG_DAT_63_32 | 31:0 | ro | 0x0 | Bits [63:32] of the data that caused the captured correctable ECC error. (Data associated with the first ECC error if multiple errors occurred since CORR_ECC_LOG_VALID was cleared) Since each ECC engine handles 8-bits of data and that is logged in register 0x34, all the 32-bits of this register will always be 0. |

Register ([ddrc](#)) CHE_CORR_ECC_DATA_71_64_REG_OFFSET

| | |
|------------------|------------------------------------|
| Name | CHE_CORR_ECC_DATA_71_64_REG_OFFSET |
| Relative Address | 0x000000D8 |
| Absolute Address | 0xF80060D8 |
| Width | 8 bits |
| Access Type | ro |
| Reset Value | 0x00000000 |
| Description | ECC error correction data log high |

Register CHE_CORR_ECC_DATA_71_64_REG_OFFSET Details

| Field Name | Bits | Type | Reset Value | Description |
|------------------------|------|------|-------------|--|
| CORR_ECC_LOG_DAT_71_64 | 7:0 | ro | 0x0 | Bits [71:64] of the data that caused the captured correctable ECC error. (Data associated with the first ECC error if multiple errors occurred since CORR_ECC_LOG_VALID was cleared) 5-bits of ECC are calculated over 8-bits of data. Bits[68:64] carries these 5-bits. Bits[71:69] are always 0. |

Register ([ddrc](#)) CHE_UNCORR_ECC_LOG_REG_OFFSET

| | |
|------------------|--------------------------------|
| Name | CHE_UNCORR_ECC_LOG_REG_OFFSET |
| Relative Address | 0x000000DC |
| Absolute Address | 0xF80060DC |
| Width | 1 bits |
| Access Type | clonwr |
| Reset Value | 0x00000000 |
| Description | ECC unrecoverable error status |

Register CHE_UNCORR_ECC_LOG_REG_OFFSET Details

| Field Name | Bits | Type | Reset Value | Description |
|--------------------------|------|------------|-------------|--|
| UNCORR_ECC_LOG_VA LID | 0 | clon wr | 0x0 | Set to 1 when an uncorrectable ECC error is captured. As long as this is a 1, no further ECC errors will be captured. This is cleared when a 1 is written to register bit[0] of ECC CONTROL REGISTER (0x31). |

Register ([ddrc](#)) CHE_UNCORR_ECC_ADDR_REG_OFFSET

| | |
|------------------|---------------------------------|
| Name | CHE_UNCORR_ECC_ADDR_REG_OFFSET |
| Relative Address | 0x000000E0 |
| Absolute Address | 0xF80060E0 |
| Width | 31 bits |
| Access Type | ro |
| Reset Value | 0x00000000 |
| Description | ECC unrecoverable error address |

Register CHE_UNCORR_ECC_ADDR_REG_OFFSET Details

| Field Name | Bits | Type | Reset Value | Description |
|-------------------------|-------|------|-------------|---------------|
| UNCORR_ECC_LOG_BA NK | 30:28 | ro | 0x0 | Bank [2:0] |
| UNCORR_ECC_LOG_RO W | 27:12 | ro | 0x0 | Row [15:0] |
| UNCORR_ECC_LOG_CO L | 11:0 | ro | 0x0 | Column [11:0] |

Register ([ddrc](#)) CHE_UNCORR_ECC_DATA_31_0_REG_OFFSET

| | |
|------------------|-------------------------------------|
| Name | CHE_UNCORR_ECC_DATA_31_0_REG_OFFSET |
| Relative Address | 0x000000E4 |
| Absolute Address | 0xF80060E4 |
| Width | 32 bits |
| Access Type | ro |
| Reset Value | 0x00000000 |
| Description | ECC unrecoverable error data low |

Register CHE_UNCORR_ECC_DATA_31_0_REG_OFFSET Details

| Field Name | Bits | Type | Reset Value | Description |
|--------------------------|------|------|-------------|--|
| UNCORR_ECC_LOG_DATA_31_0 | 31:0 | ro | 0x0 | bits [31:0] of the data that caused the captured uncorrectable ECC error. (Data associated with the first ECC error if multiple errors occurred since UNCORR_ECC_LOG_VALID was cleared). Since each ECC engine handles 8-bits of data, only the lower 8-bits of this register have valid data. The upper 24-bits will always be 0. |

Register (ddrc) CHE_UNCORR_ECC_DATA_63_32_REG_OFFSET

| | |
|------------------|--------------------------------------|
| Name | CHE_UNCORR_ECC_DATA_63_32_REG_OFFSET |
| Relative Address | 0x000000E8 |
| Absolute Address | 0xF80060E8 |
| Width | 32 bits |
| Access Type | ro |
| Reset Value | 0x00000000 |
| Description | ECC unrecoverable error data middle |

Register CHE_UNCORR_ECC_DATA_63_32_REG_OFFSET Details

| Field Name | Bits | Type | Reset Value | Description |
|---------------------------|------|------|-------------|---|
| UNCORR_ECC_LOG_DATA_63_32 | 31:0 | ro | 0x0 | bits [63:32] of the data that caused the captured uncorrectable ECC error. (Data associated with the first ECC error if multiple errors occurred since UNCORR_ECC_LOG_VALID was cleared) Since each ECC engine handles 8-bits of data and that is logged in register 0x34, all the 32-bits of this register will always be 0. |

Register (ddrc) CHE_UNCORR_ECC_DATA_71_64_REG_OFFSET

| | |
|------------------|--------------------------------------|
| Name | CHE_UNCORR_ECC_DATA_71_64_REG_OFFSET |
| Relative Address | 0x000000EC |
| Absolute Address | 0xF80060EC |
| Width | 8 bits |
| Access Type | ro |
| Reset Value | 0x00000000 |
| Description | ECC unrecoverable error data high |

Register CHE_UNCORR_ECC_DATA_71_64_REG_OFFSET Details

| Field Name | Bits | Type | Reset Value | Description |
|---------------------------|------|------|-------------|--|
| UNCORR_ECC_LOG_DATA_71_64 | 7:0 | ro | 0x0 | bits [71:64] of the data that caused the captured uncorrectable ECC error. (Data associated with the first ECC error if multiple errors occurred since UNCORR_ECC_LOG_VALID was cleared) 5-bits of ECC are calculated over 8-bits of data. Bits[68:64] carries these 5-bits. Bits[71:69] are always 0. |

Register ([ddrc](#)) CHE_ECC_STATS_REG_OFFSET

| | |
|------------------|--------------------------|
| Name | CHE_ECC_STATS_REG_OFFSET |
| Relative Address | 0x000000F0 |
| Absolute Address | 0xF80060F0 |
| Width | 16 bits |
| Access Type | clonwr |
| Reset Value | 0x00000000 |
| Description | ECC error count |

Register CHE_ECC_STATS_REG_OFFSET Details

| Field Name | Bits | Type | Reset Value | Description |
|---------------------|------|--------|-------------|---|
| STAT_NUM_CORR_ERR | 15:8 | clonwr | 0x0 | Returns the number of correctable ECC errors seen since the last read. Counter saturates at max value. This is cleared when a 1 is written to register bit[1] of ECC control register 0xF80060C4. |
| STAT_NUM_UNCORR_ERR | 7:0 | clonwr | 0x0 | Returns the number of uncorrectable errors since the last read. Counter saturates at max value. This is cleared when a 1 is written to register bit[0] of ECC control register 0xF80060C4. |

Register ([ddrc](#)) ECC_scrub

| | |
|------------------|----------------|
| Name | ECC_scrub |
| Relative Address | 0x000000F4 |
| Absolute Address | 0xF80060F4 |
| Width | 4 bits |
| Access Type | rw |
| Reset Value | 0x00000008 |
| Description | ECC mode/scrub |

Register ECC_scrub Details

| Field Name | Bits | Type | Reset Value | Description |
|--------------------|------|------|-------------|---|
| reg_ddrc_dis_scrub | 3 | rw | 0x1 | 0: Enable ECC scrubs (valid only when reg_ddrc_ecc_mode = 100). 1: Disable ECC scrubs |
| reg_ddrc_ecc_mode | 2:0 | rw | 0x0 | DRAM ECC Mode. To run the design in ECC mode, set reg_ddrc_data_bus_width to 2'b01 (Half bus width) and reg_ddrc_ecc_mode to 100. In this mode, there will be 16-data bits plus 10-bit ECC on the DRAM bus. Controller must NOT be put in full bus width mode, when ECC is turned On. 000 : No ECC. 100: SEC/DED over 1-beat others: reserve |

Register ([ddrc](#)) CHE_ECC_CORR_BIT_MASK_31_0_REG_OFFSET

| | |
|------------------|---------------------------------------|
| Name | CHE_ECC_CORR_BIT_MASK_31_0_REG_OFFSET |
| Relative Address | 0x000000F8 |
| Absolute Address | 0xF80060F8 |
| Width | 32 bits |
| Access Type | ro |
| Reset Value | 0x00000000 |
| Description | ECC data mask low |

Register CHE_ECC_CORR_BIT_MASK_31_0_REG_OFFSET Details

| Field Name | Bits | Type | Reset Value | Description |
|----------------------------|------|------|-------------|---|
| ddrc_reg_ecc_corr_bit_mask | 31:0 | ro | 0x0 | Bits [31:0] of ddrc_reg_ecc_corr_bit_mask register. Indicates the mask of the corrected data. 1: on any bit indicates that the bit has been corrected by the DRAM ECC logic 0: on any bit indicates that the bit has NOT been corrected by the DRAM ECC logic. Valid when 'STAT_NUM_CORR_ERR' is more than 0. This mask doesn't indicate any correction that has been made in the ECC check bits. If there are errors in multiple lanes, then this signal will have the mask for the lowest lane. Each ECC engine works on 8-bits of data. Hence only the lower 8-bits carry valid information. Upper 24-bits are always 0. |

Register ([ddrc](#)) CHE_ECC_CORR_BIT_MASK_63_32_REG_OFFSET

| | |
|------|--|
| Name | CHE_ECC_CORR_BIT_MASK_63_32_REG_OFFSET |
|------|--|

Relative Address 0x000000FC
 Absolute Address 0xF80060FC
 Width 32 bits
 Access Type ro
 Reset Value 0x00000000
 Description ECC data mask high

Register CHE_ECC_CORR_BIT_MASK_63_32_REG_OFFSET Details

| Field Name | Bits | Type | Reset Value | Description |
|----------------------------|------|------|-------------|--|
| ddrc_reg_ecc_corr_bit_mask | 31:0 | ro | 0x0 | Bits [63:32] of ddrc_reg_ecc_corr_bit_mask register. Indicates the mask of the corrected data. 1: on any bit indicates that the bit has been corrected by the DRAM ECC logic 0: on any bit indicates that the bit has NOT been corrected by the DRAM ECC logic. Valid when 'STAT_NUM_CORR_ERR' is more than 0. This mask doesn't indicate any correction that has been made in the ECC check bits. If there are errors in multiple lanes, then this signal will have the mask for the lowest lane. Each ECC engine works on 8-bits of data and this is reported in register 0x3E. All 32-bits of this register are 0 always. |

Register ([ddrc](#)) phy_rcvr_enable

Name phy_rcvr_enable
 Relative Address 0x00000114
 Absolute Address 0xF8006114
 Width 8 bits
 Access Type rw
 Reset Value 0x00000000
 Description Phy receiver enable register

Register phy_rcvr_enable Details

| Field Name | Bits | Type | Reset Value | Description |
|-----------------|------|------|-------------|---|
| reg_phy_dif_off | 7:4 | rw | 0x0 | Value to drive to IO receiver enable pins when turning it OFF. When in powerdown or self-refresh (CKE=0) this value will be sent to the IOs to control receiver on/off. IOD is the size specified by the IO_DIFEN_SIZE parameter. Depending on the IO, one of these signals dif_on or dif_off can be used. |
| reg_phy_dif_on | 3:0 | rw | 0x0 | Value to drive to IO receiver enable pins when turning it ON. When NOT in powerdown or self-refresh (when CKE=1) this value will be sent to the IOs to control receiver on/off. IOD is the size specified by the IO_DIFEN_SIZE parameter. |

Register ([ddrc](#)) PHY_Config0

| | |
|------------------|--|
| Name | PHY_Config0 |
| Relative Address | 0x00000118 |
| Absolute Address | 0xF8006118 |
| Width | 31 bits |
| Access Type | rw |
| Reset Value | 0x40000001 |
| Description | PHY configuration register for data slice 0. |

Note: This register is the first in an array of 4 identical registers listed in the table below. The details provided in this section apply to the entire array.

| Name | Address |
|-------------|------------|
| PHY_Config0 | 0xf8006118 |
| PHY_Config1 | 0xf800611c |
| PHY_Config2 | 0xf8006120 |
| PHY_Config3 | 0xf8006124 |

Register PHY_Config0 to PHY_Config3 Details

| Field Name | Bits | Type | Reset Value | Description |
|---------------------------|-------|------|-------------|--|
| reg_phy_dq_offset | 30:24 | rw | 0x40 | Offset value from DQS to DQ. Default value: 0x40 (for 90 degree shift). This is only used when reg_phy_use_wr_level=1. #Note: When a port width (W) is multiple of N instances of Ranks or Slices, each instance will get W/N bits. Instance n will get (n+1)*(W/N) -1: n (W/N) bits where n (0, 1, to N-1) is the instance number of Rank or Slice. |
| reserved | 23:15 | rw | 0x0 | Reserved. Do not modify. |
| reserved | 14:6 | rw | 0x0 | Reserved. Do not modify. |
| reserved | 5 | rw | 0x0 | Reserved. Do not modify. |
| reserved | 4 | rw | 0x0 | Reserved. Do not modify. |
| reg_phy_wrlvl_inc_mode | 3 | rw | 0x0 | reserved |
| reg_phy_gatelvl_inc_mode | 2 | rw | 0x0 | reserved |
| reg_phy_rdlvl_inc_mode | 1 | rw | 0x0 | reserved |
| reg_phy_data_slice_in_use | 0 | rw | 0x1 | Data bus width selection for Read FIFO RE generation. One bit for each data slice. 0: read data responses are ignored. 1: data slice is valid. Note: The Phy Data Slice 0 must always be enabled. |

Register ([ddrc](#)) phy_init_ratio0

| | |
|------------------|---|
| Name | phy_init_ratio0 |
| Relative Address | 0x0000012C |
| Absolute Address | 0xF800612C |
| Width | 20 bits |
| Access Type | rw |
| Reset Value | 0x00000000 |
| Description | PHY init ratio register for data slice 0. |

Note: This register is the first in an array of 4 identical registers listed in the table below. The details provided in this section apply to the entire array.

| Name | Address |
|-----------------|------------|
| phy_init_ratio0 | 0xf800612c |
| phy_init_ratio1 | 0xf8006130 |

| Name | Address |
|-----------------|------------|
| phy_init_ratio2 | 0xf8006134 |
| phy_init_ratio3 | 0xf8006138 |

Register phy_init_ratio0 to phy_init_ratio3 Details

| Field Name | Bits | Type | Reset Value | Description |
|----------------------------|-------|------|-------------|---|
| reg_phy_gatelvl_init_ratio | 19:10 | rw | 0x0 | The user programmable init ratio used Gate Leveling FSM |
| reg_phy_wrlvl_init_ratio | 9:0 | rw | 0x0 | The user programmable init ratio used by Write Leveling FSM |

Register ([ddrc](#)) phy_rd_dqs_cfg0

| | |
|------------------|---|
| Name | phy_rd_dqs_cfg0 |
| Relative Address | 0x00000140 |
| Absolute Address | 0xF8006140 |
| Width | 20 bits |
| Access Type | rw |
| Reset Value | 0x00000040 |
| Description | PHY read DQS configuration register for data slice 0. |

Note: This register is the first in an array of 4 identical registers listed in the table below. The details provided in this section apply to the entire array.

| Name | Address |
|-----------------|------------|
| phy_rd_dqs_cfg0 | 0xf8006140 |
| phy_rd_dqs_cfg1 | 0xf8006144 |
| phy_rd_dqs_cfg2 | 0xf8006148 |
| phy_rd_dqs_cfg3 | 0xf800614c |

Register phy_rd_dqs_cfg0 to phy_rd_dqs_cfg3 Details

| Field Name | Bits | Type | Reset Value | Description |
|----------------------------|-------|------|-------------|---|
| reg_phy_rd_dqs_slave_delay | 19:11 | rw | 0x0 | If reg_phy_rd_dqs_slave_force is 1, replace delay/tap value for read DQS slave DLL with this value. |

| Field Name | Bits | Type | Reset Value | Description |
|----------------------------|------|------|-------------|---|
| reg_phy_rd_dqs_slave_force | 10 | rw | 0x0 | 0: Use reg_phy_rd_dqs_slave_ratio for the read DQS slave DLL 1: overwrite the delay/tap value for read DQS slave DLL with the value of the reg_phy_rd_dqs_slave_delay bus. |
| reg_phy_rd_dqs_slave_ratio | 9:0 | rw | 0x40 | Ratio value for read DQS slave DLL. This is the fraction of a clock cycle represented by the shift to be applied to the read DQS in units of 256ths. In other words, the full-cycle tap value from the master DLL will be scaled by this number over 256 to get the delay value for the slave delay line. Provide a default value of 0x40 for most applications |

Register ([ddrc](#)) phy_wr_dqs_cfg0

| | |
|------------------|--|
| Name | phy_wr_dqs_cfg0 |
| Relative Address | 0x00000154 |
| Absolute Address | 0xF8006154 |
| Width | 20 bits |
| Access Type | rw |
| Reset Value | 0x00000000 |
| Description | PHY write DQS configuration register for data slice 0. |

Note: This register is the first in an array of 4 identical registers listed in the table below. The details provided in this section apply to the entire array.

| Name | Address |
|-----------------|------------|
| phy_wr_dqs_cfg0 | 0xf8006154 |
| phy_wr_dqs_cfg1 | 0xf8006158 |
| phy_wr_dqs_cfg2 | 0xf800615c |
| phy_wr_dqs_cfg3 | 0xf8006160 |

Register phy_wr_dqs_cfg0 to phy_wr_dqs_cfg3 Details

| Field Name | Bits | Type | Reset Value | Description |
|----------------------------|-------|------|-------------|--|
| reg_phy_wr_dqs_slave_delay | 19:11 | rw | 0x0 | If reg_phy_wr_dqs_slave_force is 1, replace delay/tap value for write DQS slave DLL with this value. |

| Field Name | Bits | Type | Reset Value | Description |
|----------------------------|------|------|-------------|---|
| reg_phy_wr_dqs_slave_force | 10 | rw | 0x0 | 0: Use reg_phy_wr_dqs_slave_ratio for the write DQS slave DLL 1: overwrite the delay/tap value for write DQS slave DLL with the value of the reg_phy_wr_dqs_slave_delay bus. |
| reg_phy_wr_dqs_slave_ratio | 9:0 | rw | 0x0 | Ratio value for write DQS slave DLL. This is the fraction of a clock cycle represented by the shift to be applied to the write DQS in units of 256ths. In other words, the full-cycle tap value from the master DLL will be scaled by this number over 256 to get the delay value for the slave delay line. (Used to program the manual training ratio value) |

Register ([ddrc](#)) phy_we_cfg0

| | |
|------------------|---|
| Name | phy_we_cfg0 |
| Relative Address | 0x00000168 |
| Absolute Address | 0xF8006168 |
| Width | 21 bits |
| Access Type | rw |
| Reset Value | 0x00000040 |
| Description | PHY FIFO write enable configuration for data slice 0. |

Note: This register is the first in an array of 4 identical registers listed in the table below. The details provided in this section apply to the entire array.

| Name | Address |
|-------------|------------|
| phy_we_cfg0 | 0xf8006168 |
| phy_we_cfg1 | 0xf800616c |
| phy_we_cfg2 | 0xf8006170 |
| phy_we_cfg3 | 0xf8006174 |

Register phy_we_cfg0 to phy_we_cfg3 Details

| Field Name | Bits | Type | Reset Value | Description |
|-----------------------------|-------|------|-------------|--|
| reg_phy_fifo_we_in_delay | 20:12 | rw | 0x0 | Delay value to be used when reg_phy_fifo_we_in_force is set to 1. |
| reg_phy_fifo_we_in_force | 11 | rw | 0x0 | 0: Use reg_phy_fifo_we_slave_ratio as ratio value for fifo_we_X slave DLL 1: overwrite the delay/tap value for fifo_we_X slave DLL with the value of the reg_phy_fifo_we_in_delay bus. i.e. The 'force' bit selects between specifying the delay in 'ratio' units or tap delay units |
| reg_phy_fifo_we_slave_ratio | 10:0 | rw | 0x40 | Ratio value to be used when reg_phy_fifo_we_in_force is set to 0. |

Register ([ddrc](#)) wr_data_slv0

| | |
|------------------|---|
| Name | wr_data_slv0 |
| Relative Address | 0x0000017C |
| Absolute Address | 0xF800617C |
| Width | 20 bits |
| Access Type | rw |
| Reset Value | 0x00000080 |
| Description | PHY write data slave ratio config for data slice 0. |

Note: This register is the first in an array of 4 identical registers listed in the table below. The details provided in this section apply to the entire array.

| Name | Address |
|--------------|------------|
| wr_data_slv0 | 0xf800617c |
| wr_data_slv1 | 0xf8006180 |
| wr_data_slv2 | 0xf8006184 |
| wr_data_slv3 | 0xf8006188 |

Register wr_data_slv0 to wr_data_slv3 Details

| Field Name | Bits | Type | Reset Value | Description |
|-----------------------------|-------|------|-------------|---|
| reg_phy_wr_data_slave_delay | 19:11 | rw | 0x0 | If reg_phy_wr_data_slave_force is 1, replace delay/tap value for write data slave DLL with this value. |
| reg_phy_wr_data_slave_force | 10 | rw | 0x0 | 0: Selects reg_phy_wr_data_slave_ratio for write data slave DLL 1: overwrite the delay/tap value for write data slave DLL with the value of the reg_phy_wr_data_slave_force bus. |
| reg_phy_wr_data_slave_ratio | 9:0 | rw | 0x80 | Ratio value for write data slave DLL. This is the fraction of a clock cycle represented by the shift to be applied to the write DQ muxes in units of 256ths. In other words, the full-cycle tap value from the master DLL will be scaled by this number over 256 to get the delay value for the slave delay line. |

Register ([ddrc](#)) reg_64

| | |
|------------------|--------------------|
| Name | reg_64 |
| Relative Address | 0x00000190 |
| Absolute Address | 0xF8006190 |
| Width | 32 bits |
| Access Type | rw |
| Reset Value | 0x10020000 |
| Description | Training control 2 |

Register reg_64 Details

| Field Name | Bits | Type | Reset Value | Description |
|--------------------------|-------|------|-------------|---|
| reserved | 31 | rw | 0x0 | Reserved. Do not modify. |
| reg_phy_cmd_latency | 30 | rw | 0x0 | If set to 1, command comes to phy_ctrl through a flop. |
| reg_phy_lpddr | 29 | rw | 0x0 | 0: LPDDR2, DDR2 or DDR3 1: reserved |
| reserved | 28 | rw | 0x1 | Reserved. Do not modify. |
| reg_phy_ctrl_slave_delay | 27:21 | rw | 0x0 | If reg_phy_rd_dqs_slave_force is 1, replace delay/tap value for address/command timing slave DLL with this value. This is a bit value, the remaining 2 bits are in register 0x65 bits[19:18]. |

| Field Name | Bits | Type | Reset Value | Description |
|--------------------------|-------|------|-------------|---|
| reg_phy_ctrl_slave_force | 20 | rw | 0x0 | 0: Use reg_phy_ctrl_slave_ratio for address/command timing slave DLL 1: overwrite the delay/tap value for address/command timing slave DLL with the value of the reg_phy_rd_dqs_slave_delay bus. |
| reg_phy_ctrl_slave_ratio | 19:10 | rw | 0x80 | Ratio value for address/command launch timing in phy_ctrl macro. This is the fraction of a clock cycle represented by the shift to be applied to the read DQS in units of 256ths. In other words, the full cycle tap value from the master DLL will be scaled by this number over 256 to get the delay value for the slave delay line. |
| reg_phy_sel_logic | 9 | rw | 0x0 | Selects one of the two read leveling algorithms.'b0: Select algorithm # 1'b1: Select algorithm # 2 Please refer to Read Data Eye Training section in PHY User Guide for details about the Read Leveling algorithms |
| reserved | 8 | rw | 0x0 | Reserved. Do not modify. |
| reg_phy_invert_clkout | 7 | rw | 0x0 | Inverts the polarity of DRAM clock. 0: core clock is passed on to DRAM 1: inverted core clock is passed on to DRAM. Use this when CLK can arrive at a DRAM device ahead of DQS or coincidence with DQS based on board topology. This effectively delays the CLK to the DRAM device by half -cycle, providing a CLK edge that DQS can align to during leveling. |
| reserved | 6:5 | rw | 0x0 | Reserved. Do not modify. |
| reserved | 4 | rw | 0x0 | Reserved. Do not modify. |
| reserved | 3 | rw | 0x0 | Reserved. Do not modify. |
| reserved | 2 | rw | 0x0 | Reserved. Do not modify. |
| reg_phy_bl2 | 1 | rw | 0x0 | Reserved for future Use. |
| reserved | 0 | rw | 0x0 | Reserved. Do not modify. |

Register ([ddrc](#)) reg_65

| | |
|------------------|--------------------|
| Name | reg_65 |
| Relative Address | 0x00000194 |
| Absolute Address | 0xF8006194 |
| Width | 20 bits |
| Access Type | rw |
| Reset Value | 0x00000000 |
| Description | Training control 3 |

Register reg_65 Details

| Field Name | Bits | Type | Reset Value | Description |
|-------------------------------|-------|------|-------------|--|
| reg_phy_ctrl_slave_delay | 19:18 | rw | 0x0 | If reg_phy_rd_dqs_slave_force is 1, replace delay/tap value for address/command timing slave DLL with this value |
| reg_phy_dis_calib_rst | 17 | rw | 0x0 | Disable the dll_calib (internally generated) signal from resetting the Read Capture FIFO pointers and portions of phy_data. Note: dll_calib is (i) generated by dfi_ctrl_upd_req or (ii) by the PHY when it detects that the clock frequency variation has exceeded the bounds set by reg_phy_dll_lock_diff or (iii) periodically throughout the leveling process. dll_calib will update the slave DL with PVT-compensated values according to master DLL outputs |
| reg_phy_use_rd_data_eye_level | 16 | rw | 0x0 | Read Data Eye training control. 0: Use register programmed ratio values 1: Use ratio for delay line calculated by data eye leveling Note: This is a Synchronous dynamic signal that requires timing closure |
| reg_phy_use_rd_dqs_gate_level | 15 | rw | 0x0 | Read DQS Gate training control. 0: Use register programmed ratio values 1: Use ratio for delay line calculated by DQS gate leveling Note: This is a Synchronous dynamic signal that requires timing closure. |
| reg_phy_use_wr_level | 14 | rw | 0x0 | Write Leveling training control. 0: Use register programmed ratio values 1: Use ratio for delay line calculated by write leveling Note: This is a Synchronous dynamic signal that requires timing closure. |
| reg_phy_dll_lock_diff | 13:10 | rw | 0x0 | The Maximum number of delay line taps variation allowed while maintaining the master DLL lock. When the PHY is in locked state and the variation on the clock exceeds the variation indicated by the register, the lock signal is deasserted |

| Field Name | Bits | Type | Reset Value | Description |
|---------------------|------|------|-------------|---|
| reg_phy_rd_rl_delay | 9:5 | rw | 0x0 | This delay determines when to select the active rank's ratio logic delay for Read Data and Read DQS slave delay lines after PHY receives a read command at Control Interface. The programmed value must be (Read Latency - 3) with a minimum value of 1. |
| reg_phy_wr_rl_delay | 4:0 | rw | 0x0 | This delay determines when to select the active rank's ratio logic delay for Write Data and Write DQS slave delay lines after PHY receives a write command at Control Interface. The programmed value must be (Write Latency - 4) with a minimum value of 1. |

The fifo_we_slave ratios for each slice(0 through 3) must be interpreted by software in the following way:

Slice 0: fifo_we_ratio_slice_0[10:0] = {reg69_6a1[9],reg69_6a0[18:9]}

Slice1: fifo_we_ratio_slice_1[10:0] = {reg6c_6d2[10:9],reg69_6a1[18:10]}

Slice2: fifo_we_ratio_slice_2[10:0] = {reg6c_6d3[11:9],reg6c_6d2[18:11]}

Slice3: fifo_we_ratio_slice_3[10:0] = {phy_reg_rdlvl_fifowein_ratio_slice3_msb,reg6c_6d3[18:12]}

Register ([ddrc](#)) reg69_6a0

| | |
|------------------|------------------------------------|
| Name | reg69_6a0 |
| Relative Address | 0x000001A4 |
| Absolute Address | 0xF80061A4 |
| Width | 29 bits |
| Access Type | ro |
| Reset Value | 0x00070000 |
| Description | Training results for data slice 0. |

Register reg69_6a0 Details

| Field Name | Bits | Type | Reset Value | Description |
|--|-------|------|-------------|--|
| phy_reg_status_fifo_we_slave_dll_value | 27:19 | ro | 0x0 | Delay value applied to FIFO WE slave DLL. |
| phy_reg_rdlvl_fifowein_ratio | 18:9 | ro | 0x380 | Ratio value generated by Read Gate training FSM. |
| reserved | 8:0 | ro | 0x0 | Reserved. Do not modify. |

Register ([ddrc](#)) reg69_6a1

| | |
|------------------|------------------------------------|
| Name | reg69_6a1 |
| Relative Address | 0x000001A8 |
| Absolute Address | 0xF80061A8 |
| Width | 29 bits |
| Access Type | ro |
| Reset Value | 0x00060200 |
| Description | Training results for data slice 1. |

Register reg69_6a1 Details

| Field Name | Bits | Type | Reset Value | Description |
|--|-------|------|-------------|--|
| phy_reg_status_fifo_we_slave_dll_value | 27:19 | ro | 0x0 | Delay value applied to FIFO WE slave DLL. |
| phy_reg_rdlvl_fifowein_ratio | 18:9 | ro | 0x301 | Ratio value generated by Read Gate training FSM. |
| reserved | 8:0 | ro | 0x0 | Reserved. Do not modify. |

Register ([ddrc](#)) reg6c_6d2

| | |
|------------------|------------------------------------|
| Name | reg6c_6d2 |
| Relative Address | 0x000001B0 |
| Absolute Address | 0xF80061B0 |
| Width | 28 bits |
| Access Type | ro |
| Reset Value | 0x00040600 |
| Description | Training results for data slice 2. |

Register reg6c_6d2 Details

| Field Name | Bits | Type | Reset Value | Description |
|--|-------|------|-------------|---|
| phy_reg_status_fifo_we_slave_dll_value | 27:19 | ro | 0x0 | Delay value applied to FIFO WE slave DLL. |

| Field Name | Bits | Type | Reset Value | Description |
|------------------------------|------|------|-------------|---|
| phy_reg_rdlvl_fifowein_ratio | 18:9 | ro | 0x203 | Ratio value generated by Read Gate training FSM. |
| phy_reg_bist_err | 8:0 | ro | 0x0 | Mismatch error flag from the BIST Checker. 1 bit per data slice. 1'b1: Pattern mismatch error 1'b0: All patterns matched This is a sticky flag. In order to clear this bit, port reg_phy_bist_err_clr must be set HIGH. Note that reg6b is unused. |

Register ([ddrc](#)) reg6c_6d3

| | |
|------------------|------------------------------------|
| Name | reg6c_6d3 |
| Relative Address | 0x000001B4 |
| Absolute Address | 0xF80061B4 |
| Width | 28 bits |
| Access Type | ro |
| Reset Value | 0x00000E00 |
| Description | Training results for data slice 3. |

Register reg6c_6d3 Details

| Field Name | Bits | Type | Reset Value | Description |
|--|-------|------|-------------|--|
| phy_reg_status_fifo_we_slave_dll_value | 27:19 | ro | 0x0 | Delay value applied to FIFO WE slave DLL. |
| phy_reg_rdlvl_fifowein_ratio | 18:9 | ro | 0x7 | Ratio value generated by Read Gate training FSM. |
| phy_reg_bist_err | 8:0 | ro | 0x0 | Mismatch error flag from the BIST Checker. 1 bit per data slice. 1'b1: Pattern mismatch error 1'b0: All patterns matched This is a sticky flag. In order to clear this bit, port reg_phy_bist_err_clr must be set HIGH. Note that reg6b is unused. |

Register ([ddrc](#)) reg6e_710

| | |
|------------------|--|
| Name | reg6e_710 |
| Relative Address | 0x000001B8 |
| Absolute Address | 0xF80061B8 |
| Width | 30 bits |
| Access Type | ro |
| Reset Value | x |
| Description | Training results (2) for data slice 0. |

Note: This register is the first in an array of 4 identical registers listed in the table below. The details provided in this section apply to the entire array.

| Name | Address |
|-----------|------------|
| reg6e_710 | 0xf80061b8 |
| reg6e_711 | 0xf80061bc |
| reg6e_712 | 0xf80061c0 |
| reg6e_713 | 0xf80061c4 |

Register reg6e_710 to reg6e_713 Details

| Field Name | Bits | Type | Reset Value | Description |
|-------------------------|-------|------|-------------|---|
| phy_reg_rdlvl_dqs_ratio | 29:20 | ro | x | Ratio value generated by Read Data Eye training FSM. |
| phy_reg_wrlvl_dq_ratio | 19:10 | ro | x | Ratio value generated by the write leveling FSM for Write Data. |
| phy_reg_wrlvl_dqs_ratio | 9:0 | ro | x | Ratio value generated by the write leveling FSM for Write DQS. |

Register ([ddrc](#)) phy_dll_sts0

| | |
|------------------|-------------------------------------|
| Name | phy_dll_sts0 |
| Relative Address | 0x000001CC |
| Absolute Address | 0xF80061CC |
| Width | 27 bits |
| Access Type | ro |
| Reset Value | 0x00000000 |
| Description | Slave DLL results for data slice 0. |

Note: This register is the first in an array of 4 identical registers listed in the table below. The details provided in this section apply to the entire array.

| Name | Address |
|--------------|------------|
| phy_dll_sts0 | 0xf80061cc |
| phy_dll_sts1 | 0xf80061d0 |
| phy_dll_sts2 | 0xf80061d4 |
| phy_dll_sts3 | 0xf80061d8 |

Register phy_dll_sts0 to phy_dll_sts3 Details

| Field Name | Bits | Type | Reset Value | Description |
|--|-------|------|-------------|---|
| phy_reg_status_wr_dqs_slave_dll_value | 26:18 | ro | 0x0 | Delay value applied to write DQS slave DLL |
| phy_reg_status_wr_data_slave_dll_value | 17:9 | ro | 0x0 | Delay value applied to write data slave DLL |
| phy_reg_status_rd_dqs_slave_dll_value | 8:0 | ro | 0x0 | Delay value applied to read data slave DLL |

Register ([ddrc](#)) dll_lock_sts

| | |
|------------------|-----------------------|
| Name | dll_lock_sts |
| Relative Address | 0x000001E0 |
| Absolute Address | 0xF80061E0 |
| Width | 24 bits |
| Access Type | ro |
| Reset Value | 0x00F00000 |
| Description | DLL Lock Status, read |

Register dll_lock_sts Details

| Field Name | Bits | Type | Reset Value | Description |
|--|-------|------|-------------|--|
| phy_reg_rdlvl_fifo_wein_ratio_slice3_msb | 23:20 | ro | 0xF | Used as 4-msbits of slice3's ratio value generated by Read Gate training FSM. Refer to description of reg69_6a[1:0], fifo_we_slave ratio, for more details |
| phy_reg_status_dll_slave_value_1 | 19:11 | ro | 0x0 | Shows the current Coarse and Fine delay values going to all the Slave DLLs [1:0] - Fine value (For Master DLL 1) [8:2] - Coarse value (For Master DLL 1) |
| phy_reg_status_dll_slave_value_0 | 10:2 | ro | 0x0 | Shows the current Coarse and Fine delay values going to all the Slave DLLs [1:0] - Fine value (For Master DLL 0) [8:2] - Coarse value (For Master DLL 0) |
| phy_reg_status_dll_lock_1 | 1 | ro | 0x0 | Status Master DLL 1 signal: 0: not locked 1: locked |
| phy_reg_status_dll_lock_0 | 0 | ro | 0x0 | Master DLL 0 Status signal: 0: not locked 1: locked |

Register ([ddrc](#)) phy_ctrl_sts

| | |
|------------------|--------------------------|
| Name | phy_ctrl_sts |
| Relative Address | 0x000001E4 |
| Absolute Address | 0xF80061E4 |
| Width | 30 bits |
| Access Type | ro |
| Reset Value | x |
| Description | PHY Control status, read |

Register phy_ctrl_sts Details

| Field Name | Bits | Type | Reset Value | Description |
|--|-------|------|-------------|--|
| phy_reg_status_phy_ctrl_of_in_lock_state | 29:28 | ro | 0x0 | Lock status from Master DLL Output Filter. 0: not locked, 1: locked. Bit 28: Fine delay line. Bit 29: Coarse delay line. |
| phy_reg_status_phy_ctrl_dll_slave_value | 27:20 | ro | 0x0 | Values applied to the PHY_CTRL Slave DLL: Bit field 21:20 is the Fine value Bit field 27:22 is the Course value |
| phy_reg_status_phy_ctrl_dll_lock | 19 | ro | 0x0 | PHY Control Master DLL Status: 0: not locked, 1: locked |
| phy_reg_status_of_out_delay_value | 18:10 | ro | x | Values from Master DDL Output Filter (no default value). Bit field 11:10 is the Fine value Bit field 18:12 is the Coarse value |
| phy_reg_status_of_in_delay_value | 9:0 | ro | x | Values applied to Master DDL Output Filter (no default value): Bit field 1:0 is the Fine value Bit field 9:2 is the Coarse value |

Register ([ddrc](#)) phy_ctrl_sts_reg2

| | |
|------------------|------------------------------|
| Name | phy_ctrl_sts_reg2 |
| Relative Address | 0x000001E8 |
| Absolute Address | 0xF80061E8 |
| Width | 27 bits |
| Access Type | ro |
| Reset Value | 0x00000013 |
| Description | PHY Control status (2), read |

Register phy_ctrl_sts_reg2 Details

| Field Name | Bits | Type | Reset Value | Description |
|---|-------|------|-------------|---|
| phy_reg_status_phy_ctrl_slave_dll_value | 26:18 | ro | 0x0 | Delay value applied to read DQS slave DLL. |
| reserved | 17:9 | ro | 0x0 | reserved |
| phy_reg_status_phy_ctrl_of_in_delay_value | 8:0 | ro | 0x13 | Values applied to Master DLL Output Filter: Bit field 1:0 is the Fine value Bit field 8:2 is the Coarse value |

Register ([ddrc](#)) axi_id

| | |
|------------------|-----------------------------|
| Name | axi_id |
| Relative Address | 0x00000200 |
| Absolute Address | 0xF8006200 |
| Width | 26 bits |
| Access Type | ro |
| Reset Value | 0x00153042 |
| Description | ID and revision information |

Register axi_id Details

| Field Name | Bits | Type | Reset Value | Description |
|------------------|-------|------|-------------|-----------------|
| reg_arb_rev_num | 25:20 | ro | 0x1 | Revision Number |
| reg_arb_prov_num | 19:12 | ro | 0x53 | Prov number |
| reg_arb_part_num | 11:0 | ro | 0x42 | Part Number |

Register ([ddrc](#)) page_mask

| | |
|------------------|------------|
| Name | page_mask |
| Relative Address | 0x00000204 |
| Absolute Address | 0xF8006204 |
| Width | 32 bits |
| Access Type | rw |
| Reset Value | 0x00000000 |
| Description | Page mask |

Register page_mask Details

| Field Name | Bits | Type | Reset Value | Description |
|------------------------|------|------|-------------|--|
| reg_arb_page_addr_mask | 31:0 | rw | 0x0 | Set this register based on the value programmed on the reg_ddrc_addrmap_* registers. Set the Column address bits to 0. Set the Page and Bank address bits to 1. This is used for calculating page_match inside the slave modules in Arbiter. The page_match is considered during the arbitration process. This mask applies to 64-bit address and not byte address. Setting this value to 0 disables transaction prioritization based on page/bank match. |

Register ([ddrc](#)) axi_priority_wr_port0

| | |
|------------------|--|
| Name | axi_priority_wr_port0 |
| Relative Address | 0x00000208 |
| Absolute Address | 0xF8006208 |
| Width | 20 bits |
| Access Type | mixed |
| Reset Value | 0x000803FF |
| Description | AXI Priority control for write port 0. |

Note: This register is the first in an array of 4 identical registers listed in the table below. The details provided in this section apply to the entire array.

| Name | Address |
|-----------------------|------------|
| axi_priority_wr_port0 | 0xf8006208 |
| axi_priority_wr_port1 | 0xf800620c |
| axi_priority_wr_port2 | 0xf8006210 |
| axi_priority_wr_port3 | 0xf8006214 |

Register axi_priority_wr_port0 to axi_priority_wr_port3 Details

| Field Name | Bits | Type | Reset Value | Description |
|---------------------------------|------|------|-------------|-------------------------------------|
| reserved | 19 | rw | 0x1 | Reserved. Do not modify. |
| reg_arb_dis_page_match_wr_portn | 18 | rw | 0x0 | Disable the page match feature. |
| reg_arb_disable_urgent_wr_portn | 17 | rw | 0x0 | Disable urgent for this Write Port. |
| reg_arb_disable_aging_wr_portn | 16 | rw | 0x0 | Disable aging for this Write Port. |

| Field Name | Bits | Type | Reset Value | Description |
|----------------------|-------|------|-------------|---|
| reserved | 15:10 | ro | 0x0 | Reserved |
| reg_arb_pri_wr_portn | 9:0 | rw | 0x3FF | Priority of this Write Port n. Value in this register used to load the aging counters (when respective port request is asserted and grant is generated to that port). These register can be reprogrammed to set priority of each port. Lower the value more will be priority given to the port. For example if 0x82 (port 0) value is set to 'h3FF, and 0x83 (port 1) is set to 'h0FF, and both port0 and port1 have requests, in this case port1 will get high priority and grant will be given to port1. Note that the minimum write priority should be set to 0x4. |

Register ([ddrc](#)) axi_priority_rd_port0

| | |
|------------------|---------------------------------------|
| Name | axi_priority_rd_port0 |
| Relative Address | 0x00000218 |
| Absolute Address | 0xF8006218 |
| Width | 20 bits |
| Access Type | mixed |
| Reset Value | 0x000003FF |
| Description | AXI Priority control for read port 0. |

Note: This register is the first in an array of 4 identical registers listed in the table below. The details provided in this section apply to the entire array.

| Name | Address |
|-----------------------|------------|
| axi_priority_rd_port0 | 0xf8006218 |
| axi_priority_rd_port1 | 0xf800621c |
| axi_priority_rd_port2 | 0xf8006220 |
| axi_priority_rd_port3 | 0xf8006224 |

Register axi_priority_rd_port0 to axi_priority_rd_port3 Details

| Field Name | Bits | Type | Reset Value | Description |
|---------------------------------|------|------|-------------|---|
| reg_arb_set_hpr_rd_portn | 19 | rw | 0x0 | Enable reads to be generated as HPR for this Read Port. |
| reg_arb_dis_page_match_rd_portn | 18 | rw | 0x0 | Disable the page match feature. |
| reg_arb_disable_urgent_rd_portn | 17 | rw | 0x0 | Disable urgent for this Read Port. |
| reg_arb_disable_aging_rd_portn | 16 | rw | 0x0 | Disable aging for this Read Port. |

| Field Name | Bits | Type | Reset Value | Description |
|----------------------|-------|------|-------------|---|
| reserved | 15:10 | ro | 0x0 | Reserved. Do not modify. |
| reg_arb_pri_rd_portn | 9:0 | rw | 0x3FF | Priority of this Read Port n. Value in this register used to load the aging counters (when respective port request is asserted and grant is generated to that port). These register can be reprogrammed to set priority of each port. Lower the value more will be priority given to the port. For example if 0x82 (port 0) value is set to 'h3FF, and 0x83 (port 1) is set to 'h0FF, and both port0 and port1 have requests, in this case port1 will get high priority and grant will be given to port1. |

Register ([ddrc](#)) `excl_access_cfg0`

| | |
|------------------|--|
| Name | excl_access_cfg0 |
| Relative Address | 0x00000294 |
| Absolute Address | 0xF8006294 |
| Width | 18 bits |
| Access Type | rw |
| Reset Value | 0x00000000 |
| Description | Exclusive access configuration for port 0. |

Note: This register is the first in an array of 4 identical registers listed in the table below. The details provided in this section apply to the entire array.

| Name | Address |
|------------------|------------|
| excl_access_cfg0 | 0xf8006294 |
| excl_access_cfg1 | 0xf8006298 |
| excl_access_cfg2 | 0xf800629c |
| excl_access_cfg3 | 0xf80062a0 |

Register `excl_access_cfg0` to `excl_access_cfg3` Details

| Field Name | Bits | Type | Reset Value | Description |
|-----------------------|------|------|-------------|-------------|
| reg_excl_acc_id1_port | 17:9 | rw | 0x0 | Reserved |
| reg_excl_acc_id0_port | 8:0 | rw | 0x0 | Reserved |

Register ([ddrc](#)) `mode_reg_read`

| | |
|------------------|---------------|
| Name | mode_reg_read |
| Relative Address | 0x000002A4 |

Absolute Address 0xF80062A4
 Width 32 bits
 Access Type ro
 Reset Value 0x00000000
 Description Mode register read data

Register mode_reg_read Details

This registers is applicable only when LPDDR2 is selected.

| Field Name | Bits | Type | Reset Value | Description |
|----------------------|------|------|-------------|--|
| ddrc_reg_rd_mrr_data | 31:0 | ro | 0x0 | Mode register read Data. Valid when ddrc_co_rd_mrr_data_valid is high. Bits[7:0] carry the 8-bit MRR value. Valid for LPDDR2 only. |

Register ([ddrc](#)) lpddr_ctrl0

Name lpddr_ctrl0
 Relative Address 0x000002A8
 Absolute Address 0xF80062A8
 Width 12 bits
 Access Type rw
 Reset Value 0x00000000
 Description LPDDR2 Control 0

Register lpddr_ctrl0 Details

This registers is applicable only when LPDDR2 is selected.

| Field Name | Bits | Type | Reset Value | Description |
|------------------------|------|------|-------------|--|
| reg_ddrc_mr4_margin | 11:4 | rw | 0x0 | UNUSED |
| reserved | 3 | rw | 0x0 | Reserved. Datasheet does not mention this field |
| reg_ddrc_derate_enable | 2 | rw | 0x0 | 0: Timing parameter derating is disabled. 1: Timing parameter derating is enabled using MR4 read value. This feature should only be enabled after LPDDR2 initialization is completed |

| Field Name | Bits | Type | Reset Value | Description |
|---------------------------|------|------|-------------|--|
| reg_ddrc_per_bank_refresh | 1 | rw | 0x0 | 0:All bank refresh Per bank refresh allows traffic to flow to other banks. 1:Per bank refresh Recommended setting is 0. If per bank refresh is required, please follow recommended procedure outlined in Errata. |
| reg_ddrc_lpddr2 | 0 | rw | 0x0 | 0: DDR2 or DDR3 in use. 1: LPDDR2 in Use. |

Register ([ddrc](#)) lpddr_ctrl1

| | |
|------------------|------------------|
| Name | lpddr_ctrl1 |
| Relative Address | 0x000002AC |
| Absolute Address | 0xF80062AC |
| Width | 32 bits |
| Access Type | rw |
| Reset Value | 0x00000000 |
| Description | LPDDR2 Control 1 |

Register lpddr_ctrl1 Details

| Field Name | Bits | Type | Reset Value | Description |
|----------------------------|------|------|-------------|---|
| reg_ddrc_mr4_read_interval | 31:0 | rw | 0x0 | Interval between two MR4 reads, USED to derate the timing parameters. |

Register ([ddrc](#)) lpddr_ctrl2

| | |
|------------------|------------------|
| Name | lpddr_ctrl2 |
| Relative Address | 0x000002B0 |
| Absolute Address | 0xF80062B0 |
| Width | 22 bits |
| Access Type | rw |
| Reset Value | 0x003C0015 |
| Description | LPDDR2 Control 2 |

Register lpddr_ctrl2 Details

| Field Name | Bits | Type | Reset Value | Description |
|-------------------------------|-------|------|-------------|--|
| reg_ddrc_t_mrw | 21:12 | rw | 0x3C0 | Time to wait during load mode register writes. Present only in designs configured to support LPDDR2. LPDDR2 typically requires value of 5. |
| reg_ddrc_idle_after_reset_x32 | 11:4 | rw | 0x1 | Idle time after the reset command, tINIT4. Units: 32 clock cycles. |
| reg_ddrc_min_stable_clock_x1 | 3:0 | rw | 0x5 | Time to wait after the first CKE high, tINIT2. Units: 1 clock cycle. LPDDR2 typically requires 5 x tCK delay. |

Register ([ddrc](#)) lpddr_ctrl3

| | |
|------------------|------------------|
| Name | lpddr_ctrl3 |
| Relative Address | 0x000002B4 |
| Absolute Address | 0xF80062B4 |
| Width | 18 bits |
| Access Type | rw |
| Reset Value | 0x00000601 |
| Description | LPDDR2 Control 3 |

Register lpddr_ctrl3 Details

| Field Name | Bits | Type | Reset Value | Description |
|------------------------------|------|------|-------------|---|
| reg_ddrc_dev_zqinit_x32 | 17:8 | rw | 0x6 | ZQ initial calibration, tZQINIT. Units: 32 clock cycles. LPDDR2 typically requires 1 us. |
| reg_ddrc_max_auto_init_x1024 | 7:0 | rw | 0x1 | Maximum duration of the auto initialization, tINIT5. Units: 1024 clock cycles. LPDDR2 typically requires 10 us. |

B.7 CoreSight Cross Trigger Interface (cti)

| | |
|--------------|---|
| Module Name | CoreSight Cross Trigger Interface (cti) |
| Base Address | 0xF8898000 debug_cpu_cti0 0xF8899000 debug_cpu_cti1 0xF8802000 debug_cti_etb_tpiu 0xF8809000 debug_cti_ftm |
| Description | Cross Trigger Interface |
| Vendor Info | |

Register Summary

| Register Name | Address | Width | Type | Reset Value | Description |
|-----------------------------|------------|-------|------|-------------|--|
| CTICONTROL | 0x00000000 | 1 | rw | 0x00000000 | CTI Control Register |
| CTIINTACK | 0x00000010 | 8 | wo | 0x00000000 | CTI Interrupt Acknowledge Register |
| CTIAPPSET | 0x00000014 | 4 | rw | 0x00000000 | CTI Application Trigger Set Register |
| CTIAPPCLEAR | 0x00000018 | 4 | wo | 0x00000000 | CTI Application Trigger Clear Register |
| CTIAPPULSE | 0x0000001C | 4 | wo | 0x00000000 | CTI Application Pulse Register |
| CTIINEN0 | 0x00000020 | 4 | rw | 0x00000000 | CTI Trigger to Channel Enable 0 Register |
| CTIINEN1 | 0x00000024 | 4 | rw | 0x00000000 | CTI Trigger to Channel Enable 1 Register |
| CTIINEN2 | 0x00000028 | 4 | rw | 0x00000000 | CTI Trigger to Channel Enable 2 Register |
| CTIINEN3 | 0x0000002C | 4 | rw | 0x00000000 | CTI Trigger to Channel Enable 3 Register |
| CTIINEN4 | 0x00000030 | 4 | rw | 0x00000000 | CTI Trigger to Channel Enable 4 Register |
| CTIINEN5 | 0x00000034 | 4 | rw | 0x00000000 | CTI Trigger to Channel Enable 5 Register |
| CTIINEN6 | 0x00000038 | 4 | rw | 0x00000000 | CTI Trigger to Channel Enable 6 Register |
| CTIINEN7 | 0x0000003C | 4 | rw | 0x00000000 | CTI Trigger to Channel Enable 7 Register |
| CTIOUTEN0 | 0x000000A0 | 4 | rw | 0x00000000 | CTI Channel to Trigger Enable 0 Register |
| CTIOUTEN1 | 0x000000A4 | 4 | rw | 0x00000000 | CTI Channel to Trigger Enable 1 Register |

| Register Name | Address | Width | Type | Reset Value | Description |
|----------------------------------|------------|-------|------|-------------|--|
| CTIOUTEN2 | 0x000000A8 | 4 | rw | 0x00000000 | CTI Channel to Trigger Enable 2 Register |
| CTIOUTEN3 | 0x000000AC | 4 | rw | 0x00000000 | CTI Channel to Trigger Enable 3 Register |
| CTIOUTEN4 | 0x000000B0 | 4 | rw | 0x00000000 | CTI Channel to Trigger Enable 4 Register |
| CTIOUTEN5 | 0x000000B4 | 4 | rw | 0x00000000 | CTI Channel to Trigger Enable 5 Register |
| CTIOUTEN6 | 0x000000B8 | 4 | rw | 0x00000000 | CTI Channel to Trigger Enable 6 Register |
| CTIOUTEN7 | 0x000000BC | 4 | rw | 0x00000000 | CTI Channel to Trigger Enable 7 Register |
| CTITRIGINSTATUS | 0x00000130 | 8 | ro | x | CTI Trigger In Status Register |
| CTITRIGOUTSTATUS | 0x00000134 | 8 | ro | 0x00000000 | CTI Trigger Out Status Register |
| CTICHINSTATUS | 0x00000138 | 4 | ro | x | CTI Channel In Status Register |
| CTICHOUTSTATUS | 0x0000013C | 4 | ro | 0x00000000 | CTI Channel Out Status Register |
| CTIGATE | 0x00000140 | 4 | rw | 0x0000000F | Enable CTI Channel Gate Register |
| ASICCTL | 0x00000144 | 8 | rw | 0x00000000 | External Multiplexor Control Register |
| ITCHINACK | 0x00000EDC | 4 | wo | 0x00000000 | ITCHINACK Register |
| ITTRIGINACK | 0x00000EE0 | 8 | wo | 0x00000000 | ITTRIGINACK Register |
| ITCHOUT | 0x00000EE4 | 4 | wo | 0x00000000 | ITCHOUT Register |
| ITTRIGOUT | 0x00000EE8 | 8 | wo | 0x00000000 | ITTRIGOUT Register |
| ITCHOUTACK | 0x00000EEC | 4 | ro | 0x00000000 | ITCHOUTACK Register |
| ITTRIGOUTACK | 0x00000EF0 | 8 | ro | 0x00000000 | ITTRIGOUTACK Register |
| ITCHIN | 0x00000EF4 | 4 | ro | 0x00000000 | ITCHIN Register |
| ITTRIGIN | 0x00000EF8 | 8 | ro | 0x00000000 | ITTRIGIN Register |
| ITCTRL | 0x00000F00 | 1 | rw | 0x00000000 | IT Control Register |
| CTSR | 0x00000FA0 | 4 | rw | 0x0000000F | Claim Tag Set Register |
| CTCR | 0x00000FA4 | 4 | rw | 0x00000000 | Claim Tag Clear Register |
| LAR | 0x00000FB0 | 32 | wo | 0x00000000 | Lock Access Register |
| LSR | 0x00000FB4 | 3 | ro | 0x00000003 | Lock Status Register |
| ASR | 0x00000FB8 | 4 | ro | x | Authentication Status Register |
| DEVID | 0x00000FC8 | 20 | ro | 0x00040800 | Device ID |
| DTIR | 0x00000FCC | 8 | ro | 0x00000014 | Device Type Identifier Register |
| PERIPHID4 | 0x00000FD0 | 8 | ro | 0x00000004 | Peripheral ID4 |
| PERIPHID5 | 0x00000FD4 | 8 | ro | 0x00000000 | Peripheral ID5 |
| PERIPHID6 | 0x00000FD8 | 8 | ro | 0x00000000 | Peripheral ID6 |

| Register Name | Address | Width | Type | Reset Value | Description |
|---------------------------|------------|-------|------|-------------|----------------|
| PERIPHID7 | 0x00000FDC | 8 | ro | 0x00000000 | Peripheral ID7 |
| PERIPHID0 | 0x00000FE0 | 8 | ro | 0x00000006 | Peripheral ID0 |
| PERIPHID1 | 0x00000FE4 | 8 | ro | 0x000000B9 | Peripheral ID1 |
| PERIPHID2 | 0x00000FE8 | 8 | ro | 0x0000002B | Peripheral ID2 |
| PERIPHID3 | 0x00000FEC | 8 | ro | 0x00000000 | Peripheral ID3 |
| COMPID0 | 0x00000FF0 | 8 | ro | 0x0000000D | Component ID0 |
| COMPID1 | 0x00000FF4 | 8 | ro | 0x00000090 | Component ID1 |
| COMPID2 | 0x00000FF8 | 8 | ro | 0x00000005 | Component ID2 |
| COMPID3 | 0x00000FFC | 8 | ro | 0x000000B1 | Component ID3 |

Register ([cti](#)) CTICONTROL

| | |
|------------------|---|
| Name | CTICONTROL |
| Relative Address | 0x00000000 |
| Absolute Address | debug_cpu_cti0: 0xF8898000 debug_cpu_cti1: 0xF8899000 debug_cti_etb_tpiu: 0xF8802000 debug_cti_ftm: 0xF8809000 |
| Width | 1 bits |
| Access Type | rw |
| Reset Value | 0x00000000 |
| Description | CTI Control Register |

Register CTICONTROL Details

| Field Name | Bits | Type | Reset Value | Description |
|------------|------|------|-------------|--|
| GLBEN | 0 | rw | 0x0 | Enables or disables the ECT. When disabled, all cross triggering mapping logic functionality is disabled for this processor. |

Register ([cti](#)) CTIINTACK

| | |
|------------------|---|
| Name | CTIINTACK |
| Relative Address | 0x00000010 |
| Absolute Address | debug_cpu_cti0: 0xF8898010 debug_cpu_cti1: 0xF8899010 debug_cti_etb_tpiu: 0xF8802010 debug_cti_ftm: 0xF8809010 |
| Width | 8 bits |

Access Type wo
 Reset Value 0x00000000
 Description CTI Interrupt Acknowledge Register

Register CTIINTACK Details

| Field Name | Bits | Type | Reset Value | Description |
|------------|------|------|-------------|---|
| INTACK | 7:0 | wo | 0x0 | Acknowledges the corresponding CTITRIGOUT output: 1 = CTITRIGOUT is acknowledged and is cleared when MAPTRIGOUT is LOW. 0 = no effect There is one bit of the register for each CTITRIGOUT output. |

Register (cti) CTIAPPSET

Name CTIAPPSET
 Relative Address 0x00000014
 Absolute Address debug_cpu_cti0: 0xF8898014
 debug_cpu_cti1: 0xF8899014
 debug_cti_etb_tpiu: 0xF8802014
 debug_cti_ftm: 0xF8809014
 Width 4 bits
 Access Type rw
 Reset Value 0x00000000
 Description CTI Application Trigger Set Register

Register CTIAPPSET Details

| Field Name | Bits | Type | Reset Value | Description |
|------------|------|------|-------------|--|
| APPSET | 3:0 | rw | 0x0 | Setting a bit HIGH generates a channel event for the selected channel. Read: 0 = application trigger inactive (reset) 1 = application trigger active. Write: 0 = no effect 1 = generate channel event. There is one bit of the register for each channel. |

Register (cti) CTIAPPCLEAR

| | |
|------------------|---|
| Name | CTIAPPCLEAR |
| Relative Address | 0x00000018 |
| Absolute Address | debug_cpu_cti0: 0xF8898018 debug_cpu_cti1: 0xF8899018 debug_cti_etb_tpiu: 0xF8802018 debug_cti_ftm: 0xF8809018 |
| Width | 4 bits |
| Access Type | wo |
| Reset Value | 0x00000000 |
| Description | CTI Application Trigger Clear Register |

Register CTIAPPCLEAR Details

| Field Name | Bits | Type | Reset Value | Description |
|------------|------|------|-------------|--|
| APPCLEAR | 3:0 | wo | 0x0 | Clears corresponding bits in the CTIAPPSET register. 1 = application trigger disabled in the CTIAPPSET register 0 = no effect. There is one bit of the register for each channel. |

Register (cti) CTIAPPULSE

| | |
|------------------|---|
| Name | CTIAPPULSE |
| Relative Address | 0x0000001C |
| Absolute Address | debug_cpu_cti0: 0xF889801C debug_cpu_cti1: 0xF889901C debug_cti_etb_tpiu: 0xF880201C debug_cti_ftm: 0xF880901C |
| Width | 4 bits |
| Access Type | wo |
| Reset Value | 0x00000000 |
| Description | CTI Application Pulse Register |

Register CTIAPPULSE Details

| Field Name | Bits | Type | Reset Value | Description |
|------------|------|------|-------------|---|
| APPULSE | 3:0 | wo | 0x0 | Setting a bit HIGH generates a channel event pulse for the selected channel. Write: 1 = channel event pulse generated for one CTICLK period 0 = no effect. There is one bit of the register for each channel. |

Register ([cti](#)) CTIINEN0

| | |
|------------------|---|
| Name | CTIINEN0 |
| Relative Address | 0x00000020 |
| Absolute Address | debug_cpu_cti0: 0xF8898020 debug_cpu_cti1: 0xF8899020 debug_cti_etb_tpiu: 0xF8802020 debug_cti_ftm: 0xF8809020 |
| Width | 4 bits |
| Access Type | rw |
| Reset Value | 0x00000000 |
| Description | CTI Trigger to Channel Enable 0 Register |

Register CTIINEN0 Details

| Field Name | Bits | Type | Reset Value | Description |
|------------|------|------|-------------|---|
| TRIGINEN | 3:0 | rw | 0x0 | Enables a cross trigger event to the corresponding channel when an CTITRIGIN is activated. 1 = enables the CTITRIGIN signal to generate an event on the respective channel of the CTM. There is one bit of the register for each of the four channels. For example in register CTIINEN0, TRIGINEN[0] set to 1 enables CTITRIGIN onto channel 0. 0 = disables the CTITRIGIN signal from generating an event on the respective channel of the CTM. |

Register ([cti](#)) CTIINEN1

| | |
|------------------|------------|
| Name | CTIINEN1 |
| Relative Address | 0x00000024 |

Absolute Address debug_cpu_cti0: 0xF8898024
 debug_cpu_cti1: 0xF8899024
 debug_cti_etb_tpiu: 0xF8802024
 debug_cti_ftm: 0xF8809024

Width 4 bits

Access Type rw

Reset Value 0x00000000

Description CTI Trigger to Channel Enable 1 Register

Register CTIINEN1 Details

| Field Name | Bits | Type | Reset Value | Description |
|------------|------|------|-------------|---|
| TRIGINEN | 3:0 | rw | 0x0 | Enables a cross trigger event to the corresponding channel when an CTITRIGIN is activated. 1 = enables the CTITRIGIN signal to generate an event on the respective channel of the CTM. There is one bit of the register for each of the four channels. For example in register CTIINEN0, TRIGINEN[0] set to 1 enables CTITRIGIN onto channel 0. 0 = disables the CTITRIGIN signal from generating an event on the respective channel of the CTM. |

Register (cti) CTIINEN2

Name CTIINEN2

Relative Address 0x00000028

Absolute Address debug_cpu_cti0: 0xF8898028
 debug_cpu_cti1: 0xF8899028
 debug_cti_etb_tpiu: 0xF8802028
 debug_cti_ftm: 0xF8809028

Width 4 bits

Access Type rw

Reset Value 0x00000000

Description CTI Trigger to Channel Enable 2 Register

Register CTIINEN2 Details

| Field Name | Bits | Type | Reset Value | Description |
|------------|------|------|-------------|--|
| TRIGINEN | 3:0 | rw | 0x0 | <p>Enables a cross trigger event to the corresponding channel when an CTITRIGIN is activated.</p> <p>1 = enables the CTITRIGIN signal to generate an event on the respective channel of the CTM.</p> <p>There is one bit of the register for each of the four channels. For example in register CTIINEN0, TRIGINEN[0] set to 1 enables CTITRIGIN onto channel 0.</p> <p>0 = disables the CTITRIGIN signal from generating an event on the respective channel of the CTM.</p> |

Register ([cti](#)) CTIINEN3

| | |
|------------------|---|
| Name | CTIINEN3 |
| Relative Address | 0x0000002C |
| Absolute Address | debug_cpu_cti0: 0xF889802C debug_cpu_cti1: 0xF889902C debug_cti_etb_tpiu: 0xF880202C debug_cti_ftm: 0xF880902C |
| Width | 4 bits |
| Access Type | rw |
| Reset Value | 0x00000000 |
| Description | CTI Trigger to Channel Enable 3 Register |

Register CTIINEN3 Details

| Field Name | Bits | Type | Reset Value | Description |
|------------|------|------|-------------|--|
| TRIGINEN | 3:0 | rw | 0x0 | <p>Enables a cross trigger event to the corresponding channel when an CTITRIGIN is activated.</p> <p>1 = enables the CTITRIGIN signal to generate an event on the respective channel of the CTM.</p> <p>There is one bit of the register for each of the four channels. For example in register CTIINEN0, TRIGINEN[0] set to 1 enables CTITRIGIN onto channel 0.</p> <p>0 = disables the CTITRIGIN signal from generating an event on the respective channel of the CTM.</p> |

Register ([cti](#)) CTIINEN4

| | |
|------------------|---|
| Name | CTIINEN4 |
| Relative Address | 0x00000030 |
| Absolute Address | debug_cpu_cti0: 0xF8898030 debug_cpu_cti1: 0xF8899030 debug_cti_etb_tpiu: 0xF8802030 debug_cti_ftm: 0xF8809030 |
| Width | 4 bits |
| Access Type | rw |
| Reset Value | 0x00000000 |
| Description | CTI Trigger to Channel Enable 4 Register |

Register CTIINEN4 Details

| Field Name | Bits | Type | Reset Value | Description |
|------------|------|------|-------------|---|
| TRIGINEN | 3:0 | rw | 0x0 | Enables a cross trigger event to the corresponding channel when an CTITRIGIN is activated. 1 = enables the CTITRIGIN signal to generate an event on the respective channel of the CTM. There is one bit of the register for each of the four channels. For example in register CTIINEN0, TRIGINEN[0] set to 1 enables CTITRIGIN onto channel 0. 0 = disables the CTITRIGIN signal from generating an event on the respective channel of the CTM. |

Register ([cti](#)) CTIINEN5

| | |
|------------------|---|
| Name | CTIINEN5 |
| Relative Address | 0x00000034 |
| Absolute Address | debug_cpu_cti0: 0xF8898034 debug_cpu_cti1: 0xF8899034 debug_cti_etb_tpiu: 0xF8802034 debug_cti_ftm: 0xF8809034 |
| Width | 4 bits |
| Access Type | rw |
| Reset Value | 0x00000000 |
| Description | CTI Trigger to Channel Enable 5 Register |

Register CTIINEN5 Details

| Field Name | Bits | Type | Reset Value | Description |
|------------|------|------|-------------|--|
| TRIGINEN | 3:0 | rw | 0x0 | <p>Enables a cross trigger event to the corresponding channel when an CTITRIGIN is activated.</p> <p>1 = enables the CTITRIGIN signal to generate an event on the respective channel of the CTM.</p> <p>There is one bit of the register for each of the four channels. For example in register CTIINEN0, TRIGINEN[0] set to 1 enables CTITRIGIN onto channel 0.</p> <p>0 = disables the CTITRIGIN signal from generating an event on the respective channel of the CTM.</p> |

Register ([cti](#)) CTIINEN6

| | |
|------------------|---|
| Name | CTIINEN6 |
| Relative Address | 0x00000038 |
| Absolute Address | debug_cpu_cti0: 0xF8898038 debug_cpu_cti1: 0xF8899038 debug_cti_etb_tpiu: 0xF8802038 debug_cti_ftm: 0xF8809038 |
| Width | 4 bits |
| Access Type | rw |
| Reset Value | 0x00000000 |
| Description | CTI Trigger to Channel Enable 6 Register |

Register CTIINEN6 Details

| Field Name | Bits | Type | Reset Value | Description |
|------------|------|------|-------------|--|
| TRIGINEN | 3:0 | rw | 0x0 | <p>Enables a cross trigger event to the corresponding channel when an CTITRIGIN is activated.</p> <p>1 = enables the CTITRIGIN signal to generate an event on the respective channel of the CTM.</p> <p>There is one bit of the register for each of the four channels. For example in register CTIINEN0, TRIGINEN[0] set to 1 enables CTITRIGIN onto channel 0.</p> <p>0 = disables the CTITRIGIN signal from generating an event on the respective channel of the CTM.</p> |

Register ([cti](#)) CTIINEN7

| | |
|------------------|---|
| Name | CTIINEN7 |
| Relative Address | 0x0000003C |
| Absolute Address | debug_cpu_cti0: 0xF889803C debug_cpu_cti1: 0xF889903C debug_cti_etb_tpiu: 0xF880203C debug_cti_ftm: 0xF880903C |
| Width | 4 bits |
| Access Type | rw |
| Reset Value | 0x00000000 |
| Description | CTI Trigger to Channel Enable 7 Register |

Register CTIINEN7 Details

| Field Name | Bits | Type | Reset Value | Description |
|------------|------|------|-------------|---|
| TRIGINEN | 3:0 | rw | 0x0 | Enables a cross trigger event to the corresponding channel when an CTITRIGIN is activated. 1 = enables the CTITRIGIN signal to generate an event on the respective channel of the CTM. There is one bit of the register for each of the four channels. For example in register CTIINEN0, TRIGINEN[0] set to 1 enables CTITRIGIN onto channel 0. 0 = disables the CTITRIGIN signal from generating an event on the respective channel of the CTM. |

Register ([cti](#)) CTIOUTEN0

| | |
|------------------|---|
| Name | CTIOUTEN0 |
| Relative Address | 0x000000A0 |
| Absolute Address | debug_cpu_cti0: 0xF88980A0 debug_cpu_cti1: 0xF88990A0 debug_cti_etb_tpiu: 0xF88020A0 debug_cti_ftm: 0xF88090A0 |
| Width | 4 bits |
| Access Type | rw |
| Reset Value | 0x00000000 |
| Description | CTI Channel to Trigger Enable 0 Register |

Register CTIOUTEN0 Details

| Field Name | Bits | Type | Reset Value | Description |
|------------|------|------|-------------|---|
| TRIGOUTEN | 3:0 | rw | 0x0 | Changing the value of this bit from a 0 to a 1 enables a channel event for the corresponding channel to generate an CTITRIGOUT output: 0 = the channel input (CTICHIN) from the CTM is not routed to the CTITRIGOUT output 1 = the channel input (CTICHIN) from the CTM is routed to the CTITRIGOUT output. There is one bit for each of the four channels. For example in register CTIOUTEN0, enabling bit 0 enables CTICHIN[0] to cause a trigger event on the CTITRIGOUT[0] output. |

Register ([cti](#)) CTIOUTEN1

| | |
|------------------|---|
| Name | CTIOUTEN1 |
| Relative Address | 0x000000A4 |
| Absolute Address | debug_cpu_cti0: 0xF88980A4 debug_cpu_cti1: 0xF88990A4 debug_cti_etb_tpiu: 0xF88020A4 debug_cti_ftm: 0xF88090A4 |
| Width | 4 bits |
| Access Type | rw |
| Reset Value | 0x00000000 |
| Description | CTI Channel to Trigger Enable 1 Register |

Register CTIOUTEN1 Details

| Field Name | Bits | Type | Reset Value | Description |
|------------|------|------|-------------|---|
| TRIGOUTEN | 3:0 | rw | 0x0 | Changing the value of this bit from a 0 to a 1 enables a channel event for the corresponding channel to generate an CTITRIGOUT output: 0 = the channel input (CTICHIN) from the CTM is not routed to the CTITRIGOUT output 1 = the channel input (CTICHIN) from the CTM is routed to the CTITRIGOUT output. There is one bit for each of the four channels. For example in register CTIOUTEN0, enabling bit 0 enables CTICHIN[0] to cause a trigger event on the CTITRIGOUT[0] output. |

Register (cti) CTIOUTEN2

| | |
|------------------|---|
| Name | CTIOUTEN2 |
| Relative Address | 0x000000A8 |
| Absolute Address | debug_cpu_cti0: 0xF88980A8 debug_cpu_cti1: 0xF88990A8 debug_cti_etb_tpiu: 0xF88020A8 debug_cti_ftm: 0xF88090A8 |
| Width | 4 bits |
| Access Type | rw |
| Reset Value | 0x00000000 |
| Description | CTI Channel to Trigger Enable 2 Register |

Register CTIOUTEN2 Details

| Field Name | Bits | Type | Reset Value | Description |
|------------|------|------|-------------|---|
| TRIGOUTEN | 3:0 | rw | 0x0 | Changing the value of this bit from a 0 to a 1 enables a channel event for the corresponding channel to generate an CTITRIGOUT output: 0 = the channel input (CTICHIN) from the CTM is not routed to the CTITRIGOUT output 1 = the channel input (CTICHIN) from the CTM is routed to the CTITRIGOUT output. There is one bit for each of the four channels. For example in register CTIOUTEN0, enabling bit 0 enables CTICHIN[0] to cause a trigger event on the CTITRIGOUT[0] output. |

Register (cti) CTIOUTEN3

| | |
|------------------|---|
| Name | CTIOUTEN3 |
| Relative Address | 0x000000AC |
| Absolute Address | debug_cpu_cti0: 0xF88980AC debug_cpu_cti1: 0xF88990AC debug_cti_etb_tpiu: 0xF88020AC debug_cti_ftm: 0xF88090AC |
| Width | 4 bits |
| Access Type | rw |
| Reset Value | 0x00000000 |
| Description | CTI Channel to Trigger Enable 3 Register |

Register CTIOUTEN3 Details

| Field Name | Bits | Type | Reset Value | Description |
|------------|------|------|-------------|---|
| TRIGOUTEN | 3:0 | rw | 0x0 | Changing the value of this bit from a 0 to a 1 enables a channel event for the corresponding channel to generate an CTITRIGOUT output: 0 = the channel input (CTICHIN) from the CTM is not routed to the CTITRIGOUT output 1 = the channel input (CTICHIN) from the CTM is routed to the CTITRIGOUT output. There is one bit for each of the four channels. For example in register CTIOUTEN0, enabling bit 0 enables CTICHIN[0] to cause a trigger event on the CTITRIGOUT[0] output. |

Register ([cti](#)) CTIOUTEN4

Name CTIOUTEN4
 Relative Address 0x000000B0
 Absolute Address debug_cpu_cti0: 0xF88980B0
 debug_cpu_cti1: 0xF88990B0
 debug_cti_etb_tpiu: 0xF88020B0
 debug_cti_ftm: 0xF88090B0
 Width 4 bits
 Access Type rw
 Reset Value 0x00000000
 Description CTI Channel to Trigger Enable 4 Register

Register CTIOUTEN4 Details

| Field Name | Bits | Type | Reset Value | Description |
|------------|------|------|-------------|---|
| TRIGOUTEN | 3:0 | rw | 0x0 | Changing the value of this bit from a 0 to a 1 enables a channel event for the corresponding channel to generate an CTITRIGOUT output: 0 = the channel input (CTICHIN) from the CTM is not routed to the CTITRIGOUT output 1 = the channel input (CTICHIN) from the CTM is routed to the CTITRIGOUT output. There is one bit for each of the four channels. For example in register CTIOUTEN0, enabling bit 0 enables CTICHIN[0] to cause a trigger event on the CTITRIGOUT[0] output. |

Register (cti) CTIOUTEN5

| | |
|------------------|---|
| Name | CTIOUTEN5 |
| Relative Address | 0x000000B4 |
| Absolute Address | debug_cpu_cti0: 0xF88980B4 debug_cpu_cti1: 0xF88990B4 debug_cti_etb_tpiu: 0xF88020B4 debug_cti_ftm: 0xF88090B4 |
| Width | 4 bits |
| Access Type | rw |
| Reset Value | 0x00000000 |
| Description | CTI Channel to Trigger Enable 5 Register |

Register CTIOUTEN5 Details

| Field Name | Bits | Type | Reset Value | Description |
|------------|------|------|-------------|---|
| TRIGOUTEN | 3:0 | rw | 0x0 | Changing the value of this bit from a 0 to a 1 enables a channel event for the corresponding channel to generate an CTITRIGOUT output: 0 = the channel input (CTICHIN) from the CTM is not routed to the CTITRIGOUT output 1 = the channel input (CTICHIN) from the CTM is routed to the CTITRIGOUT output. There is one bit for each of the four channels. For example in register CTIOUTEN0, enabling bit 0 enables CTICHIN[0] to cause a trigger event on the CTITRIGOUT[0] output. |

Register (cti) CTIOUTEN6

| | |
|------------------|---|
| Name | CTIOUTEN6 |
| Relative Address | 0x000000B8 |
| Absolute Address | debug_cpu_cti0: 0xF88980B8 debug_cpu_cti1: 0xF88990B8 debug_cti_etb_tpiu: 0xF88020B8 debug_cti_ftm: 0xF88090B8 |
| Width | 4 bits |
| Access Type | rw |
| Reset Value | 0x00000000 |
| Description | CTI Channel to Trigger Enable 6 Register |

Register CTIOUTEN6 Details

| Field Name | Bits | Type | Reset Value | Description |
|------------|------|------|-------------|---|
| TRIGOUTEN | 3:0 | rw | 0x0 | Changing the value of this bit from a 0 to a 1 enables a channel event for the corresponding channel to generate an CTITRIGOUT output: 0 = the channel input (CTICHIN) from the CTM is not routed to the CTITRIGOUT output 1 = the channel input (CTICHIN) from the CTM is routed to the CTITRIGOUT output. There is one bit for each of the four channels. For example in register CTIOUTEN0, enabling bit 0 enables CTICHIN[0] to cause a trigger event on the CTITRIGOUT[0] output. |

Register ([cti](#)) CTIOUTEN7

| | |
|------------------|---|
| Name | CTIOUTEN7 |
| Relative Address | 0x000000BC |
| Absolute Address | debug_cpu_cti0: 0xF88980BC debug_cpu_cti1: 0xF88990BC debug_cti_etb_tpiu: 0xF88020BC debug_cti_ftm: 0xF88090BC |
| Width | 4 bits |
| Access Type | rw |
| Reset Value | 0x00000000 |
| Description | CTI Channel to Trigger Enable 7 Register |

Register CTIOUTEN7 Details

| Field Name | Bits | Type | Reset Value | Description |
|------------|------|------|-------------|---|
| TRIGOUTEN | 3:0 | rw | 0x0 | Changing the value of this bit from a 0 to a 1 enables a channel event for the corresponding channel to generate an CTITRIGOUT output: 0 = the channel input (CTICHIN) from the CTM is not routed to the CTITRIGOUT output 1 = the channel input (CTICHIN) from the CTM is routed to the CTITRIGOUT output. There is one bit for each of the four channels. For example in register CTIOUTEN0, enabling bit 0 enables CTICHIN[0] to cause a trigger event on the CTITRIGOUT[0] output. |

Register (cti) CTITRIGINSTATUS

| | |
|------------------|---|
| Name | CTITRIGINSTATUS |
| Relative Address | 0x00000130 |
| Absolute Address | debug_cpu_cti0: 0xF8898130 debug_cpu_cti1: 0xF8899130 debug_cti_etb_tpiu: 0xF8802130 debug_cti_ftm: 0xF8809130 |
| Width | 8 bits |
| Access Type | ro |
| Reset Value | x |
| Description | CTI Trigger In Status Register |

Register CTITRIGINSTATUS Details

| Field Name | Bits | Type | Reset Value | Description |
|--------------|------|------|-------------|--|
| TRIGINSTATUS | 7:0 | ro | x | Shows the status of the CTITRIGIN inputs: 1 = CTITRIGIN is active 0 = CTITRIGIN is inactive. Because the register provides a view of the raw CTITRIGIN inputs, the reset value is unknown. There is one bit of the register for each trigger input. |

Register (cti) CTITRIGOUTSTATUS

| | |
|------------------|---|
| Name | CTITRIGOUTSTATUS |
| Relative Address | 0x00000134 |
| Absolute Address | debug_cpu_cti0: 0xF8898134 debug_cpu_cti1: 0xF8899134 debug_cti_etb_tpiu: 0xF8802134 debug_cti_ftm: 0xF8809134 |
| Width | 8 bits |
| Access Type | ro |
| Reset Value | 0x00000000 |
| Description | CTI Trigger Out Status Register |

Register CTITRIGOUTSTATUS Details

| Field Name | Bits | Type | Reset Value | Description |
|---------------|------|------|-------------|---|
| TRIGOUTSTATUS | 7:0 | ro | 0x0 | Shows the status of the CTITRIGOUT outputs. 1 = CTITRIGOUT is active 0 = CTITRIGOUT is inactive (reset). There is one bit of the register for each trigger output. |

Register ([cti](#)) CTICHINSTATUS

| | |
|------------------|---|
| Name | CTICHINSTATUS |
| Relative Address | 0x00000138 |
| Absolute Address | debug_cpu_cti0: 0xF8898138 debug_cpu_cti1: 0xF8899138 debug_cti_etb_tpiu: 0xF8802138 debug_cti_ftm: 0xF8809138 |
| Width | 4 bits |
| Access Type | ro |
| Reset Value | x |
| Description | CTI Channel In Status Register |

Register CTICHINSTATUS Details

| Field Name | Bits | Type | Reset Value | Description |
|---------------|------|------|-------------|---|
| CTICHINSTATUS | 3:0 | ro | x | Shows the status of the CTICHIN inputs: 1 = CTICHIN is active 0 = CTICHIN is inactive. Because the register provides a view of the raw CTICHIN inputs from the CTM, the reset value is unknown. There is one bit of the register for each channel input. |

Register ([cti](#)) CTICHOUTSTATUS

| | |
|------------------|---|
| Name | CTICHOUTSTATUS |
| Relative Address | 0x0000013C |
| Absolute Address | debug_cpu_cti0: 0xF889813C debug_cpu_cti1: 0xF889913C debug_cti_etb_tpiu: 0xF880213C debug_cti_ftm: 0xF880913C |
| Width | 4 bits |
| Access Type | ro |

Reset Value 0x00000000
 Description CTI Channel Out Status Register

Register CTICHOUTSTATUS Details

| Field Name | Bits | Type | Reset Value | Description |
|----------------|------|------|-------------|---|
| CTICHOUTSTATUS | 3:0 | ro | 0x0 | Shows the status of the CTICHOUT outputs. 1 = CTICHOUT is active 0 = CTICHOUT is inactive (reset). There is one bit of the register for each channel output. |

Register (cti) CTIGATE

Name CTIGATE
 Relative Address 0x00000140
 Absolute Address debug_cpu_cti0: 0xF8898140
 debug_cpu_cti1: 0xF8899140
 debug_cti_etb_tpiu: 0xF8802140
 debug_cti_ftm: 0xF8809140
 Width 4 bits
 Access Type rw
 Reset Value 0x0000000F
 Description Enable CTI Channel Gate Register

Register CTIGATE Details

| Field Name | Bits | Type | Reset Value | Description |
|------------|------|------|-------------|-------------------|
| CTIGATEEN3 | 3 | rw | 0x1 | Enable CTICHOUT3. |
| CTIGATEEN2 | 2 | rw | 0x1 | Enable CTICHOUT2. |
| CTIGATEEN1 | 1 | rw | 0x1 | Enable CTICHOUT1. |
| CTIGATEEN0 | 0 | rw | 0x1 | Enable CTICHOUT0. |

Register (cti) ASICCTL

Name ASICCTL
 Relative Address 0x00000144
 Absolute Address debug_cpu_cti0: 0xF8898144
 debug_cpu_cti1: 0xF8899144
 debug_cti_etb_tpiu: 0xF8802144
 debug_cti_ftm: 0xF8809144

Width 8 bits
 Access Type rw
 Reset Value 0x00000000
 Description External Multiplexor Control Register

Register ASICCTL Details

| Field Name | Bits | Type | Reset Value | Description |
|------------|------|------|-------------|---|
| ASICCTL | 7:0 | rw | 0x0 | Implementation defined ASIC control, value written to the register is output on ASICCTL[7:0]. |

Register (cti) ITCHINACK

Name ITCHINACK
 Relative Address 0x00000EDC
 Absolute Address debug_cpu_cti0: 0xF8898EDC
 debug_cpu_cti1: 0xF8899EDC
 debug_cti_etb_tpiu: 0xF8802EDC
 debug_cti_ftm: 0xF8809EDC
 Width 4 bits
 Access Type wo
 Reset Value 0x00000000
 Description ITCHINACK Register

Register ITCHINACK Details

| Field Name | Bits | Type | Reset Value | Description |
|------------|------|------|-------------|--|
| CTCHINACK | 3:0 | wo | 0x0 | Set the value of the CTCHINACK outputs |

Register (cti) ITTRIGINACK

Name ITTRIGINACK
 Relative Address 0x00000EE0
 Absolute Address debug_cpu_cti0: 0xF8898EE0
 debug_cpu_cti1: 0xF8899EE0
 debug_cti_etb_tpiu: 0xF8802EE0
 debug_cti_ftm: 0xF8809EE0
 Width 8 bits
 Access Type wo
 Reset Value 0x00000000

Description ITTRIGINACK Register

Register ITTRIGINACK Details

| Field Name | Bits | Type | Reset Value | Description |
|-------------|------|------|-------------|--|
| CTTRIGINACK | 7:0 | wo | 0x0 | Set the value of the CTTRIGINACK outputs |

Register (cti) ITCHOUT

Name ITCHOUT
 Relative Address 0x00000EE4
 Absolute Address debug_cpu_cti0: 0xF8898EE4
 debug_cpu_cti1: 0xF8899EE4
 debug_cti_etb_tpiu: 0xF8802EE4
 debug_cti_ftm: 0xF8809EE4
 Width 4 bits
 Access Type wo
 Reset Value 0x00000000
 Description ITCHOUT Register

Register ITCHOUT Details

| Field Name | Bits | Type | Reset Value | Description |
|------------|------|------|-------------|--------------------------------------|
| CTCHOUT | 3:0 | wo | 0x0 | Set the value of the CTCHOUT outputs |

Register (cti) ITTRIGOUT

Name ITTRIGOUT
 Relative Address 0x00000EE8
 Absolute Address debug_cpu_cti0: 0xF8898EE8
 debug_cpu_cti1: 0xF8899EE8
 debug_cti_etb_tpiu: 0xF8802EE8
 debug_cti_ftm: 0xF8809EE8
 Width 8 bits
 Access Type wo
 Reset Value 0x00000000
 Description ITTRIGOUT Register

Register ITTRIGOUT Details

| Field Name | Bits | Type | Reset Value | Description |
|------------|------|------|-------------|--|
| CTTRIGOUT | 7:0 | wo | 0x0 | Set the value of the CTTRIGOUT outputs |

Register ([cti](#)) ITCHOUTACK

| | |
|------------------|---|
| Name | ITCHOUTACK |
| Relative Address | 0x0000EEC |
| Absolute Address | debug_cpu_cti0: 0xF8898EEC debug_cpu_cti1: 0xF8899EEC debug_cti_etb_tpiu: 0xF8802EEC debug_cti_ftm: 0xF8809EEC |
| Width | 4 bits |
| Access Type | ro |
| Reset Value | 0x00000000 |
| Description | ITCHOUTACK Register |

Register ITCHOUTACK Details

| Field Name | Bits | Type | Reset Value | Description |
|------------|------|------|-------------|--|
| CTCHOUTACK | 3:0 | ro | 0x0 | Read the values of the CTCHOUTACK inputs |

Register ([cti](#)) ITTRIGOUTACK

| | |
|------------------|---|
| Name | ITTRIGOUTACK |
| Relative Address | 0x0000EF0 |
| Absolute Address | debug_cpu_cti0: 0xF8898EF0 debug_cpu_cti1: 0xF8899EF0 debug_cti_etb_tpiu: 0xF8802EF0 debug_cti_ftm: 0xF8809EF0 |
| Width | 8 bits |
| Access Type | ro |
| Reset Value | 0x00000000 |
| Description | ITTRIGOUTACK Register |

Register ITTRIGOUTACK Details

| Field Name | Bits | Type | Reset Value | Description |
|--------------|------|------|-------------|--|
| CTTRIGOUTACK | 7:0 | ro | 0x0 | Read the values of the CTTRIGOUTACK inputs |

Register (cti) ITCHIN

| | |
|------------------|---|
| Name | ITCHIN |
| Relative Address | 0x00000EF4 |
| Absolute Address | debug_cpu_cti0: 0xF8898EF4 debug_cpu_cti1: 0xF8899EF4 debug_cti_etb_tpiu: 0xF8802EF4 debug_cti_ftm: 0xF8809EF4 |
| Width | 4 bits |
| Access Type | ro |
| Reset Value | 0x00000000 |
| Description | ITCHIN Register |

Register ITCHIN Details

| Field Name | Bits | Type | Reset Value | Description |
|------------|------|------|-------------|--------------------------------------|
| CTCHIN | 3:0 | ro | 0x0 | Read the values of the CTCHIN inputs |

Register (cti) ITTRIGIN

| | |
|------------------|---|
| Name | ITTRIGIN |
| Relative Address | 0x00000EF8 |
| Absolute Address | debug_cpu_cti0: 0xF8898EF8 debug_cpu_cti1: 0xF8899EF8 debug_cti_etb_tpiu: 0xF8802EF8 debug_cti_ftm: 0xF8809EF8 |
| Width | 8 bits |
| Access Type | ro |
| Reset Value | 0x00000000 |
| Description | ITTRIGIN Register |

Register ITTRIGIN Details

| Field Name | Bits | Type | Reset Value | Description |
|------------|------|------|-------------|--|
| CTTRIGIN | 7:0 | ro | 0x0 | Read the values of the CTTRIGIN inputs |

Register (cti) ITCTRL

| | |
|------------------|------------|
| Name | ITCTRL |
| Relative Address | 0x00000F00 |

Absolute Address debug_cpu_cti0: 0xF8898F00
 debug_cpu_cti1: 0xF8899F00
 debug_cti_etb_tpiu: 0xF8802F00
 debug_cti_ftm: 0xF8809F00

Width 1 bits

Access Type rw

Reset Value 0x00000000

Description IT Control Register

Register ITCTRL Details

| Field Name | Bits | Type | Reset Value | Description |
|------------|------|------|-------------|---------------------|
| | 0 | rw | 0x0 | Enable IT Registers |

Register (cti) CTSR

Name CTSR

Relative Address 0x00000FA0

Absolute Address debug_cpu_cti0: 0xF8898FA0
 debug_cpu_cti1: 0xF8899FA0
 debug_cti_etb_tpiu: 0xF8802FA0
 debug_cti_ftm: 0xF8809FA0

Width 4 bits

Access Type rw

Reset Value 0x0000000F

Description Claim Tag Set Register

Register CTSR Details

| Field Name | Bits | Type | Reset Value | Description |
|------------|------|------|-------------|---|
| SET | 3:0 | rw | 0xF | The claim tag register is used for any interrogating tools to determine if the device is being programmed or has been programmed. Read: 1= Claim tag is implemented, 0 = Claim tag is not implemented Write: 1= Set claim tag bit, 0= No effect |

Register (cti) CTCR

Name CTCR

Relative Address 0x00000FA4
 Absolute Address debug_cpu_cti0: 0xF8898FA4
 debug_cpu_cti1: 0xF8899FA4
 debug_cti_etb_tpiu: 0xF8802FA4
 debug_cti_ftm: 0xF8809FA4
 Width 4 bits
 Access Type rw
 Reset Value 0x00000000
 Description Claim Tag Clear Register

Register CTCR Details

| Field Name | Bits | Type | Reset Value | Description |
|------------|------|------|-------------|---|
| CLEAR | 3:0 | rw | 0x0 | The claim tag register is used for any interrogating tools to determine if the device is being programmed or has been programmed. Read: Current value of claim tag. Write: 1= Clear claim tag bit, 0= No effect |

Register (cti) LAR

Name LAR
 Relative Address 0x00000FB0
 Absolute Address debug_cpu_cti0: 0xF8898FB0
 debug_cpu_cti1: 0xF8899FB0
 debug_cti_etb_tpiu: 0xF8802FB0
 debug_cti_ftm: 0xF8809FB0
 Width 32 bits
 Access Type wo
 Reset Value 0x00000000
 Description Lock Access Register

Register LAR Details

| Field Name | Bits | Type | Reset Value | Description |
|------------|------|------|-------------|---|
| KEY | 31:0 | wo | 0x0 | <p>Write Access Code.</p> <p>Write behavior depends on PADDRDBG31 pin:</p> <ul style="list-style-type: none"> - PADDRDBG31=0 (lower 2GB): <p>After reset (via PRESETDBGn), CTI is locked, i.e., writes to all other registers using lower 2GB addresses are ignored.</p> <p>To unlock, 0xC5ACCE55 must be written this register.</p> <p>After the required registers are written, to lock again, write a value other than 0xC5ACCE55 to this register.</p> <ul style="list-style-type: none"> - PADDRDBG31=1 (upper 2GB): <p>CTI is unlocked when upper 2GB addresses are used to write to all the registers.</p> <p>However, write to this register is ignored using a upper 2GB address!</p> <p>Note: read from this register always returns 0, regardless of PADDRDBG31.</p> |

Register ([cti](#)) LSR

| | |
|------------------|---|
| Name | LSR |
| Relative Address | 0x00000FB4 |
| Absolute Address | debug_cpu_cti0: 0xF8898FB4 debug_cpu_cti1: 0xF8899FB4 debug_cti_etb_tpiu: 0xF8802FB4 debug_cti_ftm: 0xF8809FB4 |
| Width | 3 bits |
| Access Type | ro |
| Reset Value | 0x00000003 |
| Description | Lock Status Register |

Register LSR Details

| Field Name | Bits | Type | Reset Value | Description |
|------------|------|------|-------------|--|
| 8BIT | 2 | ro | 0x0 | Set to 0 since CTI implements a 32-bit lock access register |
| STATUS | 1 | ro | 0x1 | Read behavior depends on PADDRDBG31 pin: - PADDRDBG31=0 (lower 2GB): When a lower 2GB address is used to read this register, this bit indicates whether CTI is in locked state (1= locked, 0= unlocked). - PADDRDBG31=1 (upper 2GB): always returns 0. |
| IMP | 0 | ro | 0x1 | Read behavior depends on PADDRDBG31 pin: - PADDRDBG31=0 (lower 2GB): always returns 1, meaning lock mechanism are implemented. - PADDRDBG31=1 (upper 2GB): always returns 0, meaning lock mechanism is NOT implemented. |

Register ([cti](#)) ASR

| | |
|------------------|---|
| Name | ASR |
| Relative Address | 0x00000FB8 |
| Absolute Address | debug_cpu_cti0: 0xF8898FB8 debug_cpu_cti1: 0xF8899FB8 debug_cti_etb_tpiu: 0xF8802FB8 debug_cti_ftm: 0xF8809FB8 |
| Width | 4 bits |
| Access Type | ro |
| Reset Value | x |
| Description | Authentication Status Register |

Register ASR Details

| Field Name | Bits | Type | Reset Value | Description |
|------------|------|------|-------------|---|
| NIDEN | 3 | ro | x | Current value of noninvasive debug enable signals |
| NIDEN_CTL | 2 | ro | 0x1 | Non-invasive debug controlled |
| IDEN | 1 | ro | x | Current value of invasive debug enable signals |
| IDEN_CTL | 0 | ro | 0x1 | Invasive debug controlled |

Register (cti) DEVID

| | |
|------------------|---|
| Name | DEVID |
| Relative Address | 0x00000FC8 |
| Absolute Address | debug_cpu_cti0: 0xF8898FC8 debug_cpu_cti1: 0xF8899FC8 debug_cti_etb_tpiu: 0xF8802FC8 debug_cti_ftm: 0xF8809FC8 |
| Width | 20 bits |
| Access Type | ro |
| Reset Value | 0x00040800 |
| Description | Device ID |

Register DEVID Details

| Field Name | Bits | Type | Reset Value | Description |
|------------|-------|------|-------------|------------------------------|
| NumChan | 19:16 | ro | 0x4 | Number of channels available |
| NumTrig | 15:8 | ro | 0x8 | Number of triggers available |
| res | 7:5 | ro | 0x0 | reserved |
| ExtMux | 4:0 | ro | 0x0 | no external muxing |

Register (cti) DTIR

| | |
|------------------|---|
| Name | DTIR |
| Relative Address | 0x00000FCC |
| Absolute Address | debug_cpu_cti0: 0xF8898FCC debug_cpu_cti1: 0xF8899FCC debug_cti_etb_tpiu: 0xF8802FCC debug_cti_ftm: 0xF8809FCC |
| Width | 8 bits |
| Access Type | ro |
| Reset Value | 0x00000014 |
| Description | Device Type Identifier Register |

Register DTIR Details

| Field Name | Bits | Type | Reset Value | Description |
|------------|------|------|-------------|--|
| | 7:0 | ro | 0x14 | major type is a debug control logic component, sub-type is cross trigger |

Register (cti) PERIPHID4

| | |
|------------------|---|
| Name | PERIPHID4 |
| Relative Address | 0x00000FD0 |
| Absolute Address | debug_cpu_cti0: 0xF8898FD0 debug_cpu_cti1: 0xF8899FD0 debug_cti_etb_tpiu: 0xF8802FD0 debug_cti_ftm: 0xF8809FD0 |
| Width | 8 bits |
| Access Type | ro |
| Reset Value | 0x00000004 |
| Description | Peripheral ID4 |

Register PERIPHID4 Details

| Field Name | Bits | Type | Reset Value | Description |
|------------|------|------|-------------|--------------------------|
| 4KB_count | 7:4 | ro | 0x0 | 4KB Count, set to 0 |
| JEP106ID | 3:0 | ro | 0x4 | JEP106 continuation code |

Register (cti) PERIPHID5

| | |
|------------------|---|
| Name | PERIPHID5 |
| Relative Address | 0x00000FD4 |
| Absolute Address | debug_cpu_cti0: 0xF8898FD4 debug_cpu_cti1: 0xF8899FD4 debug_cti_etb_tpiu: 0xF8802FD4 debug_cti_ftm: 0xF8809FD4 |
| Width | 8 bits |
| Access Type | ro |
| Reset Value | 0x00000000 |
| Description | Peripheral ID5 |

Register PERIPHID5 Details

| Field Name | Bits | Type | Reset Value | Description |
|------------|------|------|-------------|-------------|
| | 7:0 | ro | 0x0 | reserved |

Register (cti) PERIPHID6

| | |
|------|-----------|
| Name | PERIPHID6 |
|------|-----------|

Relative Address 0x00000FD8
 Absolute Address debug_cpu_cti0: 0xF8898FD8
 debug_cpu_cti1: 0xF8899FD8
 debug_cti_etb_tpiu: 0xF8802FD8
 debug_cti_ftm: 0xF8809FD8
 Width 8 bits
 Access Type ro
 Reset Value 0x00000000
 Description Peripheral ID6

Register PERIPHID6 Details

| Field Name | Bits | Type | Reset Value | Description |
|------------|------|------|-------------|-------------|
| | 7:0 | ro | 0x0 | reserved |

Register (cti) PERIPHID7

Name PERIPHID7
 Relative Address 0x00000FDC
 Absolute Address debug_cpu_cti0: 0xF8898FDC
 debug_cpu_cti1: 0xF8899FDC
 debug_cti_etb_tpiu: 0xF8802FDC
 debug_cti_ftm: 0xF8809FDC
 Width 8 bits
 Access Type ro
 Reset Value 0x00000000
 Description Peripheral ID7

Register PERIPHID7 Details

| Field Name | Bits | Type | Reset Value | Description |
|------------|------|------|-------------|-------------|
| | 7:0 | ro | 0x0 | reserved |

Register (cti) PERIPHID0

Name PERIPHID0
 Relative Address 0x00000FE0
 Absolute Address debug_cpu_cti0: 0xF8898FE0
 debug_cpu_cti1: 0xF8899FE0
 debug_cti_etb_tpiu: 0xF8802FE0
 debug_cti_ftm: 0xF8809FE0

Width 8 bits
 Access Type ro
 Reset Value 0x00000006
 Description Peripheral ID0

Register PERIPHID0 Details

| Field Name | Bits | Type | Reset Value | Description |
|------------|------|------|-------------|-------------|
| | 7:0 | ro | 0x6 | PartNumber0 |

Register (cti) PERIPHID1

Name PERIPHID1
 Relative Address 0x0000FE4
 Absolute Address debug_cpu_cti0: 0xF8898FE4
 debug_cpu_cti1: 0xF8899FE4
 debug_cti_etb_tpiu: 0xF8802FE4
 debug_cti_ftm: 0xF8809FE4
 Width 8 bits
 Access Type ro
 Reset Value 0x000000B9
 Description Peripheral ID1

Register PERIPHID1 Details

| Field Name | Bits | Type | Reset Value | Description |
|-------------|------|------|-------------|----------------------------|
| JEP106ID | 7:4 | ro | 0xB | JEP106 Identity Code [3:0] |
| PartNumber1 | 3:0 | ro | 0x9 | PartNumber1 |

Register (cti) PERIPHID2

Name PERIPHID2
 Relative Address 0x0000FE8
 Absolute Address debug_cpu_cti0: 0xF8898FE8
 debug_cpu_cti1: 0xF8899FE8
 debug_cti_etb_tpiu: 0xF8802FE8
 debug_cti_ftm: 0xF8809FE8
 Width 8 bits
 Access Type ro
 Reset Value 0x0000002B

Description Peripheral ID2

Register PERIPHID2 Details

| Field Name | Bits | Type | Reset Value | Description |
|------------|------|------|-------------|---|
| RevNum | 7:4 | ro | 0x2 | Revision number of Peripheral |
| JEDEC | 3 | ro | 0x1 | Indicates that a JEDEC assigned value is used |
| JEP106ID | 2:0 | ro | 0x3 | JEP106 Identity Code [6:4] |

Register (cti) PERIPHID3

Name PERIPHID3
 Relative Address 0x00000FEC
 Absolute Address debug_cpu_cti0: 0xF8898FEC
 debug_cpu_cti1: 0xF8899FEC
 debug_cti_etb_tpiu: 0xF8802FEC
 debug_cti_ftm: 0xF8809FEC
 Width 8 bits
 Access Type ro
 Reset Value 0x00000000
 Description Peripheral ID3

Register PERIPHID3 Details

| Field Name | Bits | Type | Reset Value | Description |
|------------|------|------|-------------|----------------------|
| RevAnd | 7:4 | ro | 0x0 | RevAnd, at top level |
| CustMod | 3:0 | ro | 0x0 | Customer Modified |

Register (cti) COMPID0

Name COMPID0
 Relative Address 0x00000FF0
 Absolute Address debug_cpu_cti0: 0xF8898FF0
 debug_cpu_cti1: 0xF8899FF0
 debug_cti_etb_tpiu: 0xF8802FF0
 debug_cti_ftm: 0xF8809FF0
 Width 8 bits
 Access Type ro
 Reset Value 0x0000000D
 Description Component ID0

Register COMPID0 Details

| Field Name | Bits | Type | Reset Value | Description |
|------------|------|------|-------------|-------------|
| | 7:0 | ro | 0xD | Preamble |

Register ([cti](#)) COMPID1

| | |
|------------------|---|
| Name | COMPID1 |
| Relative Address | 0x00000FF4 |
| Absolute Address | debug_cpu_cti0: 0xF8898FF4 debug_cpu_cti1: 0xF8899FF4 debug_cti_etb_tpiu: 0xF8802FF4 debug_cti_ftm: 0xF8809FF4 |
| Width | 8 bits |
| Access Type | ro |
| Reset Value | 0x00000090 |
| Description | Component ID1 |

Register COMPID1 Details

| Field Name | Bits | Type | Reset Value | Description |
|------------|------|------|-------------|-------------|
| | 7:0 | ro | 0x90 | Preamble |

Register ([cti](#)) COMPID2

| | |
|------------------|---|
| Name | COMPID2 |
| Relative Address | 0x00000FF8 |
| Absolute Address | debug_cpu_cti0: 0xF8898FF8 debug_cpu_cti1: 0xF8899FF8 debug_cti_etb_tpiu: 0xF8802FF8 debug_cti_ftm: 0xF8809FF8 |
| Width | 8 bits |
| Access Type | ro |
| Reset Value | 0x00000005 |
| Description | Component ID2 |

Register COMPID2 Details

| Field Name | Bits | Type | Reset Value | Description |
|------------|------|------|-------------|-------------|
| | 7:0 | ro | 0x5 | Preamble |

Register ([cti](#)) COMPID3

| | |
|------------------|---|
| Name | COMPID3 |
| Relative Address | 0x00000FFC |
| Absolute Address | debug_cpu_cti0: 0xF8898FFC debug_cpu_cti1: 0xF8899FFC debug_cti_etb_tpiu: 0xF8802FFC debug_cti_ftm: 0xF8809FFC |
| Width | 8 bits |
| Access Type | ro |
| Reset Value | 0x000000B1 |
| Description | Component ID3 |

Register COMPID3 Details

| Field Name | Bits | Type | Reset Value | Description |
|------------|------|------|-------------|-------------|
| | 7:0 | ro | 0xB1 | Preamble |

B.8 Performance Monitor Unit (cortexa9_pmu)

| | |
|--------------|--|
| Module Name | Performance Monitor Unit (cortexa9_pmu) |
| Base Address | 0xF8891000 debug_cpu_pmu0 0xF8893000 debug_cpu_pmu1 |
| Description | Cortex A9 Performance Monitoring Unit |
| Vendor Info | Arm |

Register Summary

| Register Name | Address | Width | Type | Reset Value | Description |
|-----------------------------|------------|-------|------|-------------|---------------------|
| PMXEVCNTR0 | 0x00000000 | 32 | rw | x | PMU event counter 0 |
| PMXEVCNTR1 | 0x00000004 | 32 | rw | x | PMU event counter 1 |
| PMXEVCNTR2 | 0x00000008 | 32 | rw | x | PMU event counter 2 |
| PMXEVCNTR3 | 0x0000000C | 32 | rw | x | PMU event counter 3 |
| PMXEVCNTR4 | 0x00000010 | 32 | rw | x | PMU event counter 4 |
| PMXEVCNTR5 | 0x00000014 | 32 | rw | x | PMU event counter 5 |
| PMCCNTR | 0x0000007C | 32 | rw | x | pmccntr |
| PMXEVTYPER0 | 0x00000400 | 32 | rw | x | pmevtyper0 |
| PMXEVTYPER1 | 0x00000404 | 32 | rw | x | pmevtyper1 |
| PMXEVTYPER2 | 0x00000408 | 32 | rw | x | pmevtyper2 |
| PMXEVTYPER3 | 0x0000040C | 32 | rw | x | pmevtyper3 |
| PMXEVTYPER4 | 0x00000410 | 32 | rw | x | pmevtyper4 |
| PMXEVTYPER5 | 0x00000414 | 32 | rw | x | pmevtyper5 |
| PMCNTENSET | 0x00000C00 | 32 | rw | 0x00000000 | pmcntenset |
| PMCNTENCLR | 0x00000C20 | 32 | rw | 0x00000000 | pmcntenclr |
| PMINTENSET | 0x00000C40 | 32 | rw | 0x00000000 | pmintenset |
| PMINTENCLR | 0x00000C60 | 32 | rw | 0x00000000 | pmintenclr |
| PMOVSr | 0x00000C80 | 32 | rw | x | pmovsr |
| PMSWINC | 0x00000CA0 | 32 | wo | x | pmswinc |
| PMCR | 0x00000E04 | 32 | rw | 0x41093000 | pmcr |
| PMUSERENR | 0x00000E08 | 32 | rw | 0x00000000 | pmuserenr |

Register ([cortexa9_pmu](#)) PMXEVCNTR0

| | |
|------------------|------------|
| Name | PMXEVCNTR0 |
| Relative Address | 0x00000000 |

Absolute Address debug_cpu_pmu0: 0xF8891000
 debug_cpu_pmu1: 0xF8893000
 Width 32 bits
 Access Type rw
 Reset Value x
 Description PMU event counter 0

Register PMXEVCNTR0 Details

| Field Name | Bits | Type | Reset Value | Description |
|------------|------|------|-------------|---------------------|
| PMXEVCNTR0 | 31:0 | rw | x | PMU event counter 0 |

Register ([cortexa9_pmu](#)) PMXEVCNTR1

Name PMXEVCNTR1
 Relative Address 0x00000004
 Absolute Address debug_cpu_pmu0: 0xF8891004
 debug_cpu_pmu1: 0xF8893004
 Width 32 bits
 Access Type rw
 Reset Value x
 Description PMU event counter 1

Register PMXEVCNTR1 Details

| Field Name | Bits | Type | Reset Value | Description |
|------------|------|------|-------------|---------------------|
| PMXEVCNTR1 | 31:0 | rw | x | PMU event counter 1 |

Register ([cortexa9_pmu](#)) PMXEVCNTR2

Name PMXEVCNTR2
 Relative Address 0x00000008
 Absolute Address debug_cpu_pmu0: 0xF8891008
 debug_cpu_pmu1: 0xF8893008
 Width 32 bits
 Access Type rw
 Reset Value x
 Description PMU event counter 2

Register PMXEVCNTR2 Details

| Field Name | Bits | Type | Reset Value | Description |
|------------|------|------|-------------|---------------------|
| PMXEVCNTR2 | 31:0 | rw | x | PMU event counter 2 |

Register ([cortexa9_pmu](#)) PMXEVCNTR3

| | |
|------------------|--|
| Name | PMXEVCNTR3 |
| Relative Address | 0x0000000C |
| Absolute Address | debug_cpu_pmu0: 0xF889100C debug_cpu_pmu1: 0xF889300C |
| Width | 32 bits |
| Access Type | rw |
| Reset Value | x |
| Description | PMU event counter 3 |

Register PMXEVCNTR3 Details

| Field Name | Bits | Type | Reset Value | Description |
|------------|------|------|-------------|---------------------|
| PMXEVCNTR3 | 31:0 | rw | x | PMU event counter 3 |

Register ([cortexa9_pmu](#)) PMXEVCNTR4

| | |
|------------------|--|
| Name | PMXEVCNTR4 |
| Relative Address | 0x00000010 |
| Absolute Address | debug_cpu_pmu0: 0xF8891010 debug_cpu_pmu1: 0xF8893010 |
| Width | 32 bits |
| Access Type | rw |
| Reset Value | x |
| Description | PMU event counter 4 |

Register PMXEVCNTR4 Details

| Field Name | Bits | Type | Reset Value | Description |
|------------|------|------|-------------|---------------------|
| PMXEVCNTR4 | 31:0 | rw | x | PMU event counter 4 |

Register ([cortexa9_pmu](#)) PMXEVCNTR5

| | |
|------|------------|
| Name | PMXEVCNTR5 |
|------|------------|

Relative Address 0x00000014
 Absolute Address debug_cpu_pmu0: 0xF8891014
 debug_cpu_pmu1: 0xF8893014
 Width 32 bits
 Access Type rw
 Reset Value x
 Description PMU event counter 5

Register PMXEVCNTR5 Details

| Field Name | Bits | Type | Reset Value | Description |
|------------|------|------|-------------|---------------------|
| PMXEVCNTR5 | 31:0 | rw | x | PMU event counter 5 |

Register ([cortexa9_pmu](#)) PMCCNTR

Name PMCCNTR
 Relative Address 0x0000007C
 Absolute Address debug_cpu_pmu0: 0xF889107C
 debug_cpu_pmu1: 0xF889307C
 Width 32 bits
 Access Type rw
 Reset Value x
 Description pmccntr

Register PMCCNTR Details

| Field Name | Bits | Type | Reset Value | Description |
|------------|------|------|-------------|-------------|
| PMCCNTR | 31:0 | rw | x | pmccntr |

Register ([cortexa9_pmu](#)) PMXEVTYPER0

Name PMXEVTYPER0
 Relative Address 0x00000400
 Absolute Address debug_cpu_pmu0: 0xF8891400
 debug_cpu_pmu1: 0xF8893400
 Width 32 bits
 Access Type rw
 Reset Value x
 Description pmevtyper0

Register PMXEVTYPER0 Details

| Field Name | Bits | Type | Reset Value | Description |
|-------------|------|------|-------------|-------------|
| PMXEVTYPER0 | 31:0 | rw | x | pmevtyper0 |

Register ([cortexa9_pmu](#)) PMXEVTYPER1

| | |
|------------------|--|
| Name | PMXEVTYPER1 |
| Relative Address | 0x00000404 |
| Absolute Address | debug_cpu_pmu0: 0xF8891404 debug_cpu_pmu1: 0xF8893404 |
| Width | 32 bits |
| Access Type | rw |
| Reset Value | x |
| Description | pmevtyper1 |

Register PMXEVTYPER1 Details

| Field Name | Bits | Type | Reset Value | Description |
|-------------|------|------|-------------|-------------|
| PMXEVTYPER1 | 31:0 | rw | x | pmevtyper1 |

Register ([cortexa9_pmu](#)) PMXEVTYPER2

| | |
|------------------|--|
| Name | PMXEVTYPER2 |
| Relative Address | 0x00000408 |
| Absolute Address | debug_cpu_pmu0: 0xF8891408 debug_cpu_pmu1: 0xF8893408 |
| Width | 32 bits |
| Access Type | rw |
| Reset Value | x |
| Description | pmevtyper2 |

Register PMXEVTYPER2 Details

| Field Name | Bits | Type | Reset Value | Description |
|-------------|------|------|-------------|-------------|
| PMXEVTYPER2 | 31:0 | rw | x | pmevtyper2 |

Register ([cortexa9_pmu](#)) PMXEVTYPER3

| | |
|------|-------------|
| Name | PMXEVTYPER3 |
|------|-------------|

Relative Address 0x0000040C
 Absolute Address debug_cpu_pmu0: 0xF889140C
 debug_cpu_pmu1: 0xF889340C
 Width 32 bits
 Access Type rw
 Reset Value x
 Description pmevtyper3

Register PMXEVTYPER3 Details

| Field Name | Bits | Type | Reset Value | Description |
|-------------|------|------|-------------|-------------|
| PMXEVTYPER3 | 31:0 | rw | x | pmevtyper3 |

Register ([cortexa9_pmu](#)) PMXEVTYPER4

Name PMXEVTYPER4
 Relative Address 0x00000410
 Absolute Address debug_cpu_pmu0: 0xF8891410
 debug_cpu_pmu1: 0xF8893410
 Width 32 bits
 Access Type rw
 Reset Value x
 Description pmevtyper4

Register PMXEVTYPER4 Details

| Field Name | Bits | Type | Reset Value | Description |
|-------------|------|------|-------------|-------------|
| PMXEVTYPER4 | 31:0 | rw | x | pmevtyper4 |

Register ([cortexa9_pmu](#)) PMXEVTYPER5

Name PMXEVTYPER5
 Relative Address 0x00000414
 Absolute Address debug_cpu_pmu0: 0xF8891414
 debug_cpu_pmu1: 0xF8893414
 Width 32 bits
 Access Type rw
 Reset Value x
 Description pmevtyper5

Register PMXEVTYPER5 Details

| Field Name | Bits | Type | Reset Value | Description |
|-------------|------|------|-------------|-------------|
| PMXEVTYPER5 | 31:0 | rw | x | pmevtyper5 |

Register ([cortexa9_pmu](#)) PMCNTENSET

| | |
|------------------|--|
| Name | PMCNTENSET |
| Relative Address | 0x00000C00 |
| Absolute Address | debug_cpu_pmu0: 0xF8891C00 debug_cpu_pmu1: 0xF8893C00 |
| Width | 32 bits |
| Access Type | rw |
| Reset Value | 0x00000000 |
| Description | pmcntenset |

Register PMCNTENSET Details

| Field Name | Bits | Type | Reset Value | Description |
|------------|------|------|-------------|-------------|
| PMCNTENSET | 31:0 | rw | 0x0 | pmcntenset |

Register ([cortexa9_pmu](#)) PMCNTENCLR

| | |
|------------------|--|
| Name | PMCNTENCLR |
| Relative Address | 0x00000C20 |
| Absolute Address | debug_cpu_pmu0: 0xF8891C20 debug_cpu_pmu1: 0xF8893C20 |
| Width | 32 bits |
| Access Type | rw |
| Reset Value | 0x00000000 |
| Description | pmcntenclr |

Register PMCNTENCLR Details

| Field Name | Bits | Type | Reset Value | Description |
|------------|------|------|-------------|-------------|
| PMCNTENCLR | 31:0 | rw | 0x0 | pmcntenclr |

Register ([cortexa9_pmu](#)) PMINTENSET

| | |
|------|------------|
| Name | PMINTENSET |
|------|------------|

Relative Address 0x00000C40
 Absolute Address debug_cpu_pmu0: 0xF8891C40
 debug_cpu_pmu1: 0xF8893C40
 Width 32 bits
 Access Type rw
 Reset Value 0x00000000
 Description pmintenset

Register PMINTENSET Details

| Field Name | Bits | Type | Reset Value | Description |
|------------|------|------|-------------|-------------|
| PMINTENSET | 31:0 | rw | 0x0 | pmintenset |

Register ([cortexa9_pmu](#)) PMINTENCLR

Name PMINTENCLR
 Relative Address 0x00000C60
 Absolute Address debug_cpu_pmu0: 0xF8891C60
 debug_cpu_pmu1: 0xF8893C60
 Width 32 bits
 Access Type rw
 Reset Value 0x00000000
 Description pmintenclr

Register PMINTENCLR Details

| Field Name | Bits | Type | Reset Value | Description |
|------------|------|------|-------------|-------------|
| PMINTENCLR | 31:0 | rw | 0x0 | pmintenclr |

Register ([cortexa9_pmu](#)) PMOVSR

Name PMOVSR
 Relative Address 0x00000C80
 Absolute Address debug_cpu_pmu0: 0xF8891C80
 debug_cpu_pmu1: 0xF8893C80
 Width 32 bits
 Access Type rw
 Reset Value x
 Description pmovsr

Register PMOVSR Details

| Field Name | Bits | Type | Reset Value | Description |
|------------|------|------|-------------|-------------|
| PMOVSR | 31:0 | rw | x | pmovsr |

Register ([cortexa9_pmu](#)) PMSWINC

| | |
|------------------|--|
| Name | PMSWINC |
| Relative Address | 0x00000CA0 |
| Absolute Address | debug_cpu_pmu0: 0xF8891CA0 debug_cpu_pmu1: 0xF8893CA0 |
| Width | 32 bits |
| Access Type | wo |
| Reset Value | x |
| Description | pmswinc |

Register PMSWINC Details

| Field Name | Bits | Type | Reset Value | Description |
|------------|------|------|-------------|-------------|
| PMSWINC | 31:0 | wo | x | pmswinc |

Register ([cortexa9_pmu](#)) PMCR

| | |
|------------------|--|
| Name | PMCR |
| Relative Address | 0x00000E04 |
| Absolute Address | debug_cpu_pmu0: 0xF8891E04 debug_cpu_pmu1: 0xF8893E04 |
| Width | 32 bits |
| Access Type | rw |
| Reset Value | 0x41093000 |
| Description | pmcr |

Register PMCR Details

| Field Name | Bits | Type | Reset Value | Description |
|------------|------|------|-------------|-------------|
| PMCR | 31:0 | rw | 0x41093000 | pmcr |

Register ([cortexa9_pmu](#)) PMUSERENR

| | |
|------|-----------|
| Name | PMUSERENR |
|------|-----------|

Relative Address 0x00000E08
 Absolute Address debug_cpu_pmu0: 0xF8891E08
 debug_cpu_pmu1: 0xF8893E08
 Width 32 bits
 Access Type rw
 Reset Value 0x00000000
 Description pmuserenr

Register PMUSERENR Details

| Field Name | Bits | Type | Reset Value | Description |
|------------|------|------|-------------|---|
| PMUSERENR | 31:0 | rw | 0x0 | pmuserenr This register is read-only in user mode. |

B.9 CoreSight Program Trace Macrocell (ptm)

| | |
|--------------|--|
| Module Name | CoreSight Program Trace Macrocell (ptm) |
| Base Address | 0xF889C000 debug_cpu_ptm0 0xF889D000 debug_cpu_ptm1 |
| Description | CoreSight PTM-A9 |
| Vendor Info | |

Register Summary

| Register Name | Address | Width | Type | Reset Value | Description |
|----------------------------|------------|-------|-------|-------------|---|
| ETMCR | 0x00000000 | 30 | rw | 0x00000401 | Main Control Register |
| ETMCCR | 0x00000004 | 32 | ro | 0x8D294004 | Configuration Code Register |
| ETMTRIGGER | 0x00000008 | 17 | rw | 0x00000000 | Trigger Event Register |
| ETMSR | 0x00000010 | 4 | mixed | 0x00000002 | Status Register |
| ETMSCR | 0x00000014 | 15 | ro | 0x00000000 | System Configuration Register |
| ETMTSSCR | 0x00000018 | 24 | rw | 0x00000000 | TraceEnable Start/Stop Control Register |
| ETMTTEVR | 0x00000020 | 32 | rw | 0x00000000 | TraceEnable Event |
| ETMTECR1 | 0x00000024 | 26 | rw | 0x00000000 | TraceEnable Control Register 1 |
| ETMACVR1 | 0x00000040 | 32 | rw | 0x00000000 | Address Comparator Value Register 1 |
| ETMACVR2 | 0x00000044 | 32 | rw | 0x00000000 | Address Comparator Value Register 2 |
| ETMACVR3 | 0x00000048 | 32 | rw | 0x00000000 | Address Comparator Value Register 3 |
| ETMACVR4 | 0x0000004C | 32 | rw | 0x00000000 | Address Comparator Value Register 4 |
| ETMACVR5 | 0x00000050 | 32 | rw | 0x00000000 | Address Comparator Value Register 5 |
| ETMACVR6 | 0x00000054 | 32 | rw | 0x00000000 | Address Comparator Value Register 6 |
| ETMACVR7 | 0x00000058 | 32 | rw | 0x00000000 | Address Comparator Value Register 7 |
| ETMACVR8 | 0x0000005C | 32 | rw | 0x00000000 | Address Comparator Value Register 8 |
| ETMACTR1 | 0x00000080 | 12 | mixed | 0x00000001 | Address Comparator Access Type Register 1 |
| ETMACTR2 | 0x00000084 | 12 | mixed | 0x00000001 | Address Comparator Access Type Register 2 |

| Register Name | Address | Width | Type | Reset Value | Description |
|-------------------------------|------------|-------|-------|-------------|--|
| ETMACTR3 | 0x00000088 | 12 | mixed | 0x00000001 | Address Comparator Access Type Register 3 |
| ETMACTR4 | 0x0000008C | 12 | mixed | 0x00000001 | Address Comparator Access Type Register 4 |
| ETMACTR5 | 0x00000090 | 12 | mixed | 0x00000001 | Address Comparator Access Type Register 5 |
| ETMACTR6 | 0x00000094 | 12 | mixed | 0x00000001 | Address Comparator Access Type Register 6 |
| ETMACTR7 | 0x00000098 | 12 | mixed | 0x00000001 | Address Comparator Access Type Register 7 |
| ETMACTR8 | 0x0000009C | 12 | mixed | 0x00000001 | Address Comparator Access Type Register 8 |
| ETMCNTRLDVR1 | 0x00000140 | 16 | rw | 0x00000000 | Counter Reload Value Register 1 |
| ETMCNTRLDVR2 | 0x00000144 | 16 | rw | 0x00000000 | Counter Reload Value Register 2 |
| ETMCNTENR1 | 0x00000150 | 18 | mixed | 0x00020000 | Counter Enable Event Register 1 |
| ETMCNTENR2 | 0x00000154 | 18 | mixed | 0x00020000 | Counter Enable Event Register 2 |
| ETMCNTRLDEVR1 | 0x00000160 | 17 | rw | 0x00000000 | Counter Reload Event Register 1 |
| ETMCNTRLDEVR2 | 0x00000164 | 17 | rw | 0x00000000 | Counter Reload Event Register 2 |
| ETMCNTRV1 | 0x00000170 | 16 | rw | 0x00000000 | Counter Value Register 1 |
| ETMCNTRV2 | 0x00000174 | 16 | rw | 0x00000000 | Counter Value Register 2 |
| ETMSQ12EVR | 0x00000180 | 17 | rw | 0x00000000 | Sequencer State Transition Event Register 12 |
| ETMSQ21EVR | 0x00000184 | 17 | rw | 0x00000000 | Sequencer State Transition Event Register 21 |
| ETMSQ23EVR | 0x00000188 | 17 | rw | 0x00000000 | Sequencer State Transition Event Register 23 |
| ETMSQ31EVR | 0x0000018C | 17 | rw | 0x00000000 | Sequencer State Transition Event Register 31 |
| ETMSQ32EVR | 0x00000190 | 17 | rw | 0x00000000 | Sequencer State Transition Event Register 32 |
| ETMSQ13EVR | 0x00000194 | 17 | rw | 0x00000000 | Sequencer State Transition Event Register 13 |
| ETMSQR | 0x0000019C | 2 | rw | 0x00000000 | Current Sequencer State Register |
| ETMEXTOUTEVR1 | 0x000001A0 | 17 | rw | 0x00000000 | External Output Event Register 1 |
| ETMEXTOUTEVR2 | 0x000001A4 | 17 | rw | 0x00000000 | External Output Event Register 2 |
| ETMCIDCVR1 | 0x000001B0 | 32 | rw | 0x00000000 | Context ID Comparator Value Register |
| ETMCIDCMR | 0x000001BC | 32 | rw | 0x00000000 | Context ID Comparator Mask Register |
| ETMSYNCFR | 0x000001E0 | 12 | mixed | 0x00000400 | Synchronization Frequency Register |

| Register Name | Address | Width | Type | Reset Value | Description |
|------------------------------|------------|-------|------|-------------|--|
| ETMIDR | 0x000001E4 | 32 | ro | 0x411CF301 | ID Register |
| ETMCCER | 0x000001E8 | 26 | ro | 0x000008EA | Configuration Code Extension Register |
| ETMEXTINSELR | 0x000001EC | 14 | rw | 0x00000000 | Extended External Input Selection Register |
| ETMTSEVR | 0x000001F8 | 32 | rw | 0x00000000 | Timestamp Event |
| ETMAUXCR | 0x000001FC | 4 | rw | 0x00000000 | Auxiliary Control Register |
| ETMTRACEIDR | 0x00000200 | 7 | rw | 0x00000000 | CoreSight Trace ID Register |
| OSLSR | 0x00000304 | 32 | ro | 0x00000000 | OS Lock Status Register |
| ETMPDSR | 0x00000314 | 32 | ro | 0x00000001 | Device Powerdown Status Register |
| ITMISCOUT | 0x00000EDC | 10 | wo | 0x00000000 | Miscellaneous Outputs Register |
| ITMISCIN | 0x00000EE0 | 7 | ro | x | Miscellaneous Inputs Register |
| ITTRIGGER | 0x00000EE8 | 1 | wo | 0x00000000 | Trigger Register |
| ITATBDATA0 | 0x00000EEC | 5 | wo | 0x00000000 | ATB Data 0 Register |
| ITATBCTR2 | 0x00000EF0 | 2 | ro | x | ATB Control 2 Register |
| ITATBID | 0x00000EF4 | 7 | wo | 0x00000000 | ATB Identification Register |
| ITATBCTR0 | 0x00000EF8 | 10 | wo | 0x00000000 | ATB Control 0 Register |
| ETMITCTRL | 0x00000F00 | 1 | rw | 0x00000000 | Integration Mode Control Register |
| CTSR | 0x00000FA0 | 8 | rw | 0x000000FF | Claim Tag Set Register |
| CTCR | 0x00000FA4 | 8 | rw | 0x00000000 | Claim Tag Clear Register |
| LAR | 0x00000FB0 | 32 | wo | 0x00000000 | Lock Access Register |
| LSR | 0x00000FB4 | 3 | ro | 0x00000003 | Lock Status Register |
| ASR | 0x00000FB8 | 8 | ro | x | Authentication Status Register |
| DEVID | 0x00000FC8 | 32 | ro | 0x00000000 | Device ID |
| DTIR | 0x00000FCC | 32 | ro | 0x00000013 | Device Type Identifier (ETMDEVTYPE) |
| PERIPHID4 | 0x00000FD0 | 8 | ro | 0x00000004 | Peripheral ID4 |
| PERIPHID5 | 0x00000FD4 | 8 | ro | 0x00000000 | Peripheral ID5 |
| PERIPHID6 | 0x00000FD8 | 8 | ro | 0x00000000 | Peripheral ID6 |
| PERIPHID7 | 0x00000FDC | 8 | ro | 0x00000000 | Peripheral ID7 |
| PERIPHID0 | 0x00000FE0 | 8 | ro | 0x00000050 | Peripheral ID0 |
| PERIPHID1 | 0x00000FE4 | 8 | ro | 0x000000B9 | Peripheral ID1 |
| PERIPHID2 | 0x00000FE8 | 8 | ro | 0x0000001B | Peripheral ID2 |
| PERIPHID3 | 0x00000FEC | 8 | ro | 0x00000000 | Peripheral ID3 |
| COMPID0 | 0x00000FF0 | 8 | ro | 0x0000000D | Component ID0 |
| COMPID1 | 0x00000FF4 | 8 | ro | 0x00000090 | Component ID1 |

| Register Name | Address | Width | Type | Reset Value | Description |
|-------------------------|------------|-------|------|-------------|---------------|
| COMPID2 | 0x00000FF8 | 8 | ro | 0x00000005 | Component ID2 |
| COMPID3 | 0x00000FFC | 8 | ro | 0x000000B1 | Component ID3 |

Register ([ptm](#)) ETMCR

| | |
|------------------|--|
| Name | ETMCR |
| Relative Address | 0x00000000 |
| Absolute Address | debug_cpu_ptm0: 0xF889C000 debug_cpu_ptm1: 0xF889D000 |
| Width | 30 bits |
| Access Type | rw |
| Reset Value | 0x00000401 |
| Description | Main Control Register |

Register ETMCR Details

| Field Name | Bits | Type | Reset Value | Description |
|---------------|-------|------|-------------|---|
| ReturnStackEn | 29 | rw | 0x0 | Return stack enable |
| TimestampEn | 28 | rw | 0x0 | Timestamp enable |
| ProcSelect | 27:25 | rw | 0x0 | Select for external multiplexor if PTM is shared between multiple processors. |
| reserved | 24:16 | rw | 0x0 | Reserved |
| ContextIDSize | 15:14 | rw | 0x0 | Context ID Size Enumerated Value List: NONE=0. 8BIT=1. 16BIT=2. 32BIT=3. |
| reserved | 13 | rw | 0x0 | Reserved |
| CycleAccurate | 12 | rw | 0x0 | Enables cycle counting |
| reserved | 11 | rw | 0x0 | Reserved |
| ProgBit | 10 | rw | 0x1 | This bit must be set to b1 when the PTM is being programmed. |
| DebugReqCtrl | 9 | rw | 0x0 | Debug Request Control When set to b1 and the trigger event occurs, the PTMDBGRQ output is asserted until PTMDBGACK is observed. This enables a debugger to force the processor into Debug state. |
| BranchOutput | 8 | rw | 0x0 | When this bit is set to b1, addresses are output for all executed branches, both direct and indirect. |

| Field Name | Bits | Type | Reset Value | Description |
|------------|------|------|-------------|---|
| reserved | 7:1 | rw | 0x0 | Reserved |
| PowerDown | 0 | rw | 0x1 | This bit enables external control of the PTM. This bit must be cleared by the trace software tools at the beginning of a debug session. When this bit is set to b0, both the PTM and the trace interface in the processor are enabled. To avoid corruption of trace data, this bit must not be set before the Programming Status bit in the PTM Status Register has been read as 1. |

Register ([ptm](#)) ETMCCR

| | |
|------------------|--|
| Name | ETMCCR |
| Relative Address | 0x00000004 |
| Absolute Address | debug_cpu_ptm0: 0xF889C004 debug_cpu_ptm1: 0xF889D004 |
| Width | 32 bits |
| Access Type | ro |
| Reset Value | 0x8D294004 |
| Description | Configuration Code Register |

Register ETMCCR Details

| Field Name | Bits | Type | Reset Value | Description |
|----------------|-------|------|-------------|--|
| IDRegPresent | 31 | ro | 0x1 | Indicates that the ID Register is present. |
| reserved | 30:28 | ro | 0x0 | Reserved |
| SoftwareAccess | 27 | ro | 0x1 | Indicates that software access is supported. |
| TraceSSB | 26 | ro | 0x1 | Indicates that the trace start/stop block is present. |
| NumCntxtIDComp | 25:24 | ro | 0x1 | Specifies the number of Context ID comparators, one. |
| FIFOFULLLogic | 23 | ro | 0x0 | Indicates that it is not possible to stall the processor to prevent FIFO overflow. |
| NumExtOut | 22:20 | ro | 0x2 | Specifies the number of external outputs, two. |
| NumExtIn | 19:17 | ro | 0x4 | Specifies the number of external inputs, four. |
| Sequencer | 16 | ro | 0x1 | Indicates that the sequencer is present. |
| NumCounters | 15:13 | ro | 0x2 | Specifies the number of counters, two. |
| reserved | 12:4 | ro | 0x0 | Reserved |
| NumAddrComp | 3:0 | ro | 0x4 | Specifies the number of address comparator pairs, four. |

Register ([ptm](#)) ETMTRIGGER

| | |
|------------------|--|
| Name | ETMTRIGGER |
| Relative Address | 0x00000008 |
| Absolute Address | debug_cpu_ptm0: 0xF889C008 debug_cpu_ptm1: 0xF889D008 |
| Width | 17 bits |
| Access Type | rw |
| Reset Value | 0x00000000 |
| Description | Trigger Event Register |

Register ETMTRIGGER Details

| Field Name | Bits | Type | Reset Value | Description |
|------------|------|------|-------------|---|
| TrigEvent | 16:0 | rw | 0x0 | Trigger event. Subdivided as: Function, bits [16:14] Specifies the function that combines the two resources that define the event. Resource B, bits [13:7] and Resource A, bits [6:0] Specify the two resources that are combined by the logical operation specified by the Function field. |

Register ([ptm](#)) ETMSR

| | |
|------------------|--|
| Name | ETMSR |
| Relative Address | 0x00000010 |
| Absolute Address | debug_cpu_ptm0: 0xF889C010 debug_cpu_ptm1: 0xF889D010 |
| Width | 4 bits |
| Access Type | mixed |
| Reset Value | 0x00000002 |
| Description | Status Register |

Register ETMSR Details

| Field Name | Bits | Type | Reset Value | Description |
|------------|------|------|-------------|--|
| TrigFlag | 3 | rw | 0x0 | Trigger bit. Set when the trigger occurs and prevents the trigger from being output until the PTM is next programmed. |
| TSSRStat | 2 | rw | 0x0 | Holds the current status of the trace start/stop resource. If set to 1, indicates that a trace start address has been matched, without a corresponding trace stop address match. |
| ProgBit | 1 | ro | 0x1 | Effective state of the Programming bit. You must wait for this bit to go to b1 before starting to program the PTM. |
| Overflow | 0 | ro | 0x0 | If set to 1, there is an overflow that has not yet been traced. |

Register ([ptm](#)) ETMSCR

| | |
|------------------|--|
| Name | ETMSCR |
| Relative Address | 0x00000014 |
| Absolute Address | debug_cpu_ptm0: 0xF889C014 debug_cpu_ptm1: 0xF889D014 |
| Width | 15 bits |
| Access Type | ro |
| Reset Value | 0x00000000 |
| Description | System Configuration Register |

Register ETMSCR Details

| Field Name | Bits | Type | Reset Value | Description |
|------------|-------|------|-------------|---|
| NumProcs | 14:12 | ro | 0x0 | Number of supported processors minus 1. |
| reserved | 11:9 | ro | 0x0 | Reserved |
| FIFOFULL | 8 | ro | 0x0 | FIFOFULL not supported |
| reserved | 7:0 | ro | 0x0 | Reserved |

Register ([ptm](#)) ETMTSSCR

| | |
|------------------|--|
| Name | ETMTSSCR |
| Relative Address | 0x00000018 |
| Absolute Address | debug_cpu_ptm0: 0xF889C018 debug_cpu_ptm1: 0xF889D018 |
| Width | 24 bits |

Access Type rw
 Reset Value 0x00000000
 Description TraceEnable Start/Stop Control Register

Register ETMTSSCR Details

| Field Name | Bits | Type | Reset Value | Description |
|--------------|-------|------|-------------|---|
| StopAddrSel | 23:16 | rw | 0x0 | When a bit is set to 1, it selects a single address comparator (8-1) as a stop address for the TraceEnable Start/Stop block. For example, if you set bit [16] to 1 it selects single address comparator 1 as a stop address. |
| reserved | 15:8 | rw | 0x0 | Reserved |
| StartAddrSel | 7:0 | rw | 0x0 | When a bit is set to 1, it selects a single address comparator (8-1) as a start address for the TraceEnable Start/Stop block. For example, if you set bit [0] to 1 it selects single address comparator 1 as a start address. |

Register ([ptm](#)) ETMTEEVR

Name ETMTEEVR
 Relative Address 0x00000020
 Absolute Address debug_cpu_ptm0: 0xF889C020
 debug_cpu_ptm1: 0xF889D020
 Width 32 bits
 Access Type rw
 Reset Value 0x00000000
 Description TraceEnable Event

Register ETMTEEVR Details

| Field Name | Bits | Type | Reset Value | Description |
|------------|-------|------|-------------|---|
| reserved | 31:17 | rw | 0x0 | reserved |
| Function | 16:14 | rw | 0x0 | Specifies the logical operation that combines the two resources that define the event. |
| ResourceB | 13:7 | rw | 0x0 | See [ResourceA] bit decription. |
| ResourceA | 6:0 | rw | 0x0 | Specify the two resources that are combined by the logical operation specified by the Function field. |

Register ([ptm](#)) ETMTECR1

| | |
|------------------|--|
| Name | ETMTECR1 |
| Relative Address | 0x00000024 |
| Absolute Address | debug_cpu_ptm0: 0xF889C024 debug_cpu_ptm1: 0xF889D024 |
| Width | 26 bits |
| Access Type | rw |
| Reset Value | 0x00000000 |
| Description | TraceEnable Control Register 1 |

Register ETMTECR1 Details

| Field Name | Bits | Type | Reset Value | Description |
|-------------|------|------|-------------|---|
| TraceSSEn | 25 | rw | 0x0 | Trace start/stop control enable. The possible values of this bit are: 0 Tracing is unaffected by the trace start/stop logic. 1 Tracing is controlled by the trace on and off addresses configured for the trace start/stop logic. The trace start/stop resource is not affected by the value of this bit. |
| ExclncFlag | 24 | rw | 0x0 | Exclude/include flag. The possible values of this bit are: 0 Include. The specified address range comparators indicate the regions where tracing can occur. No tracing occurs outside this region. 1 Exclude. The specified address range comparators indicate regions to be excluded from the trace. When outside an exclude region, tracing can occur. |
| reserved | 23:4 | rw | 0x0 | Reserved |
| AddrCompSel | 3:0 | rw | 0x0 | When a bit is set to 1, it selects an address range comparator, 4-1, for include/exclude control. For example, bit [0] set to 1 selects address range comparator 1. |

Register ([ptm](#)) ETMACVR1

| | |
|------------------|------------|
| Name | ETMACVR1 |
| Relative Address | 0x00000040 |

Absolute Address debug_cpu_ptm0: 0xF889C040
 debug_cpu_ptm1: 0xF889D040
 Width 32 bits
 Access Type rw
 Reset Value 0x00000000
 Description Address Comparator Value Register 1

Register ETMACVR1 Details

| Field Name | Bits | Type | Reset Value | Description |
|------------|------|------|-------------|------------------------|
| Address | 31:0 | rw | 0x0 | Address for comparison |

Register ([ptm](#)) ETMACVR2

Name ETMACVR2
 Relative Address 0x00000044
 Absolute Address debug_cpu_ptm0: 0xF889C044
 debug_cpu_ptm1: 0xF889D044
 Width 32 bits
 Access Type rw
 Reset Value 0x00000000
 Description Address Comparator Value Register 2

Register ETMACVR2 Details

| Field Name | Bits | Type | Reset Value | Description |
|------------|------|------|-------------|------------------------|
| Address | 31:0 | rw | 0x0 | Address for comparison |

Register ([ptm](#)) ETMACVR3

Name ETMACVR3
 Relative Address 0x00000048
 Absolute Address debug_cpu_ptm0: 0xF889C048
 debug_cpu_ptm1: 0xF889D048
 Width 32 bits
 Access Type rw
 Reset Value 0x00000000
 Description Address Comparator Value Register 3

Register ETMACVR3 Details

| Field Name | Bits | Type | Reset Value | Description |
|------------|------|------|-------------|------------------------|
| Address | 31:0 | rw | 0x0 | Address for comparison |

Register ([ptm](#)) ETMACVR4

| | |
|------------------|--|
| Name | ETMACVR4 |
| Relative Address | 0x0000004C |
| Absolute Address | debug_cpu_ptm0: 0xF889C04C debug_cpu_ptm1: 0xF889D04C |
| Width | 32 bits |
| Access Type | rw |
| Reset Value | 0x00000000 |
| Description | Address Comparator Value Register 4 |

Register ETMACVR4 Details

| Field Name | Bits | Type | Reset Value | Description |
|------------|------|------|-------------|------------------------|
| Address | 31:0 | rw | 0x0 | Address for comparison |

Register ([ptm](#)) ETMACVR5

| | |
|------------------|--|
| Name | ETMACVR5 |
| Relative Address | 0x00000050 |
| Absolute Address | debug_cpu_ptm0: 0xF889C050 debug_cpu_ptm1: 0xF889D050 |
| Width | 32 bits |
| Access Type | rw |
| Reset Value | 0x00000000 |
| Description | Address Comparator Value Register 5 |

Register ETMACVR5 Details

| Field Name | Bits | Type | Reset Value | Description |
|------------|------|------|-------------|------------------------|
| Address | 31:0 | rw | 0x0 | Address for comparison |

Register ([ptm](#)) ETMACVR6

| | |
|------|----------|
| Name | ETMACVR6 |
|------|----------|

Relative Address 0x00000054
 Absolute Address debug_cpu_ptm0: 0xF889C054
 debug_cpu_ptm1: 0xF889D054
 Width 32 bits
 Access Type rw
 Reset Value 0x00000000
 Description Address Comparator Value Register 6

Register ETMACVR6 Details

| Field Name | Bits | Type | Reset Value | Description |
|------------|------|------|-------------|------------------------|
| Address | 31:0 | rw | 0x0 | Address for comparison |

Register ([ptm](#)) ETMACVR7

Name ETMACVR7
 Relative Address 0x00000058
 Absolute Address debug_cpu_ptm0: 0xF889C058
 debug_cpu_ptm1: 0xF889D058
 Width 32 bits
 Access Type rw
 Reset Value 0x00000000
 Description Address Comparator Value Register 7

Register ETMACVR7 Details

| Field Name | Bits | Type | Reset Value | Description |
|------------|------|------|-------------|------------------------|
| Address | 31:0 | rw | 0x0 | Address for comparison |

Register ([ptm](#)) ETMACVR8

Name ETMACVR8
 Relative Address 0x0000005C
 Absolute Address debug_cpu_ptm0: 0xF889C05C
 debug_cpu_ptm1: 0xF889D05C
 Width 32 bits
 Access Type rw
 Reset Value 0x00000000
 Description Address Comparator Value Register 8

Register ETMACVR8 Details

| Field Name | Bits | Type | Reset Value | Description |
|------------|------|------|-------------|------------------------|
| Address | 31:0 | rw | 0x0 | Address for comparison |

Register ([ptm](#)) ETMACTR1

| | |
|------------------|--|
| Name | ETMACTR1 |
| Relative Address | 0x00000080 |
| Absolute Address | debug_cpu_ptm0: 0xF889C080 debug_cpu_ptm1: 0xF889D080 |
| Width | 12 bits |
| Access Type | mixed |
| Reset Value | 0x00000001 |
| Description | Address Comparator Access Type Register 1 |

Register ETMACTR1 Details

| Field Name | Bits | Type | Reset Value | Description |
|-------------------|-------|------|-------------|--|
| SecLevelCtrl | 11:10 | rw | 0x0 | Security level control Enumerated Value List: IGNORE=0. NONSEC=1. SECURE=2. |
| ContextIDCompCtrl | 9:8 | rw | 0x0 | Context ID comparator control. Enumerated Value List: IGNORE=0. MATCH1=1. MATCH2=2. MATCH3=3. |
| reserved | 7:3 | rw | 0x0 | Reserved |
| AccessType | 2:0 | ro | 0x1 | Access type. Returns the value: Instruction execute. |

Register ([ptm](#)) ETMACTR2

| | |
|------------------|--|
| Name | ETMACTR2 |
| Relative Address | 0x00000084 |
| Absolute Address | debug_cpu_ptm0: 0xF889C084 debug_cpu_ptm1: 0xF889D084 |
| Width | 12 bits |
| Access Type | mixed |

Reset Value 0x00000001
 Description Address Comparator Access Type Register 2

Register ETMACTR2 Details

| Field Name | Bits | Type | Reset Value | Description |
|-------------------|-------|------|-------------|--|
| SecLevelCtrl | 11:10 | rw | 0x0 | Security level control Enumerated Value List: IGNORE=0. NONSEC=1. SECURE=2. |
| ContextIDCompCtrl | 9:8 | rw | 0x0 | Context ID comparator control. Enumerated Value List: IGNORE=0. MATCH1=1. MATCH2=2. MATCH3=3. |
| reserved | 7:3 | rw | 0x0 | Reserved |
| AccessType | 2:0 | ro | 0x1 | Access type. Returns the value: Instruction execute. |

Register ([ptm](#)) ETMACTR3

Name ETMACTR3
 Relative Address 0x00000088
 Absolute Address debug_cpu_ptm0: 0xF889C088
 debug_cpu_ptm1: 0xF889D088
 Width 12 bits
 Access Type mixed
 Reset Value 0x00000001
 Description Address Comparator Access Type Register 3

Register ETMACTR3 Details

| Field Name | Bits | Type | Reset Value | Description |
|-------------------|-------|------|-------------|--|
| SecLevelCtrl | 11:10 | rw | 0x0 | Security level control Enumerated Value List: IGNORE=0. NONSEC=1. SECURE=2. |
| ContextIDCompCtrl | 9:8 | rw | 0x0 | Context ID comparator control. Enumerated Value List: IGNORE=0. MATCH1=1. MATCH2=2. MATCH3=3. |
| reserved | 7:3 | rw | 0x0 | Reserved |
| AccessType | 2:0 | ro | 0x1 | Access type. Returns the value: Instruction execute. |

Register ([ptm](#)) ETMACTR4

| | |
|------------------|--|
| Name | ETMACTR4 |
| Relative Address | 0x0000008C |
| Absolute Address | debug_cpu_ptm0: 0xF889C08C debug_cpu_ptm1: 0xF889D08C |
| Width | 12 bits |
| Access Type | mixed |
| Reset Value | 0x00000001 |
| Description | Address Comparator Access Type Register 4 |

Register ETMACTR4 Details

| Field Name | Bits | Type | Reset Value | Description |
|-------------------|-------|------|-------------|--|
| SecLevelCtrl | 11:10 | rw | 0x0 | Security level control Enumerated Value List: IGNORE=0. NONSEC=1. SECURE=2. |
| ContextIDCompCtrl | 9:8 | rw | 0x0 | Context ID comparator control. Enumerated Value List: IGNORE=0. MATCH1=1. MATCH2=2. MATCH3=3. |

| Field Name | Bits | Type | Reset Value | Description |
|------------|------|------|-------------|--|
| reserved | 7:3 | rw | 0x0 | Reserved |
| AccessType | 2:0 | ro | 0x1 | Access type. Returns the value: Instruction execute. |

Register ([ptm](#)) ETMACTR5

| | |
|------------------|--|
| Name | ETMACTR5 |
| Relative Address | 0x00000090 |
| Absolute Address | debug_cpu_ptm0: 0xF889C090 debug_cpu_ptm1: 0xF889D090 |
| Width | 12 bits |
| Access Type | mixed |
| Reset Value | 0x00000001 |
| Description | Address Comparator Access Type Register 5 |

Register ETMACTR5 Details

| Field Name | Bits | Type | Reset Value | Description |
|-------------------|-------|------|-------------|--|
| SecLevelCtrl | 11:10 | rw | 0x0 | Security level control Enumerated Value List: IGNORE=0. NONSEC=1. SECURE=2. |
| ContextIDCompCtrl | 9:8 | rw | 0x0 | Context ID comparator control. Enumerated Value List: IGNORE=0. MATCH1=1. MATCH2=2. MATCH3=3. |
| reserved | 7:3 | rw | 0x0 | Reserved |
| AccessType | 2:0 | ro | 0x1 | Access type. Returns the value: Instruction execute. |

Register ([ptm](#)) ETMACTR6

| | |
|------------------|--|
| Name | ETMACTR6 |
| Relative Address | 0x00000094 |
| Absolute Address | debug_cpu_ptm0: 0xF889C094 debug_cpu_ptm1: 0xF889D094 |
| Width | 12 bits |
| Access Type | mixed |

Reset Value 0x00000001
 Description Address Comparator Access Type Register 6

Register ETMACTR6 Details

| Field Name | Bits | Type | Reset Value | Description |
|-------------------|-------|------|-------------|--|
| SecLevelCtrl | 11:10 | rw | 0x0 | Security level control Enumerated Value List: IGNORE=0. NONSEC=1. SECURE=2. |
| ContextIDCompCtrl | 9:8 | rw | 0x0 | Context ID comparator control. Enumerated Value List: IGNORE=0. MATCH1=1. MATCH2=2. MATCH3=3. |
| reserved | 7:3 | rw | 0x0 | Reserved |
| AccessType | 2:0 | ro | 0x1 | Access type. Returns the value: Instruction execute. |

Register ([ptm](#)) ETMACTR7

Name ETMACTR7
 Relative Address 0x00000098
 Absolute Address debug_cpu_ptm0: 0xF889C098
 debug_cpu_ptm1: 0xF889D098
 Width 12 bits
 Access Type mixed
 Reset Value 0x00000001
 Description Address Comparator Access Type Register 7

Register ETMACTR7 Details

| Field Name | Bits | Type | Reset Value | Description |
|-------------------|-------|------|-------------|--|
| SecLevelCtrl | 11:10 | rw | 0x0 | Security level control Enumerated Value List: IGNORE=0. NONSEC=1. SECURE=2. |
| ContextIDCompCtrl | 9:8 | rw | 0x0 | Context ID comparator control. Enumerated Value List: IGNORE=0. MATCH1=1. MATCH2=2. MATCH3=3. |
| reserved | 7:3 | rw | 0x0 | Reserved |
| AccessType | 2:0 | ro | 0x1 | Access type. Returns the value: Instruction execute. |

Register ([ptm](#)) ETMACTR8

| | |
|------------------|--|
| Name | ETMACTR8 |
| Relative Address | 0x0000009C |
| Absolute Address | debug_cpu_ptm0: 0xF889C09C debug_cpu_ptm1: 0xF889D09C |
| Width | 12 bits |
| Access Type | mixed |
| Reset Value | 0x00000001 |
| Description | Address Comparator Access Type Register 8 |

Register ETMACTR8 Details

| Field Name | Bits | Type | Reset Value | Description |
|-------------------|-------|------|-------------|--|
| SecLevelCtrl | 11:10 | rw | 0x0 | Security level control Enumerated Value List: IGNORE=0. NONSEC=1. SECURE=2. |
| ContextIDCompCtrl | 9:8 | rw | 0x0 | Context ID comparator control. Enumerated Value List: IGNORE=0. MATCH1=1. MATCH2=2. MATCH3=3. |

| Field Name | Bits | Type | Reset Value | Description |
|------------|------|------|-------------|--|
| reserved | 7:3 | rw | 0x0 | Reserved |
| AccessType | 2:0 | ro | 0x1 | Access type. Returns the value: Instruction execute. |

Register ([ptm](#)) ETMCNTRLDVR1

| | |
|------------------|--|
| Name | ETMCNTRLDVR1 |
| Relative Address | 0x00000140 |
| Absolute Address | debug_cpu_ptm0: 0xF889C140 debug_cpu_ptm1: 0xF889D140 |
| Width | 16 bits |
| Access Type | rw |
| Reset Value | 0x00000000 |
| Description | Counter Reload Value Register 1 |

Register ETMCNTRLDVR1 Details

| Field Name | Bits | Type | Reset Value | Description |
|------------|------|------|-------------|-----------------------|
| InitValue | 15:0 | rw | 0x0 | Counter initial value |

Register ([ptm](#)) ETMCNTRLDVR2

| | |
|------------------|--|
| Name | ETMCNTRLDVR2 |
| Relative Address | 0x00000144 |
| Absolute Address | debug_cpu_ptm0: 0xF889C144 debug_cpu_ptm1: 0xF889D144 |
| Width | 16 bits |
| Access Type | rw |
| Reset Value | 0x00000000 |
| Description | Counter Reload Value Register 2 |

Register ETMCNTRLDVR2 Details

| Field Name | Bits | Type | Reset Value | Description |
|------------|------|------|-------------|-----------------------|
| InitValue | 15:0 | rw | 0x0 | Counter initial value |

Register ([ptm](#)) ETMCNTENR1

| | |
|------|------------|
| Name | ETMCNTENR1 |
|------|------------|

Relative Address 0x00000150
 Absolute Address debug_cpu_ptm0: 0xF889C150
 debug_cpu_ptm1: 0xF889D150
 Width 18 bits
 Access Type mixed
 Reset Value 0x00020000
 Description Counter Enable Event Register 1

Register ETMCNTENR1 Details

| Field Name | Bits | Type | Reset Value | Description |
|-------------|------|------|-------------|--|
| Reserved_1 | 17 | ro | 0x1 | Reserved, RAO/WI |
| ExtOutEvent | 16:0 | rw | 0x0 | Count enable event. Subdivided as: Function, bits [16:14] Specifies the function that combines the two resources that define the event. Resource B, bits [13:7] and Resource A, bits [6:0] Specify the two resources that are combined by the logical operation specified by the Function field. |

Register ([ptm](#)) ETMCNTENR2

Name ETMCNTENR2
 Relative Address 0x00000154
 Absolute Address debug_cpu_ptm0: 0xF889C154
 debug_cpu_ptm1: 0xF889D154
 Width 18 bits
 Access Type mixed
 Reset Value 0x00020000
 Description Counter Enable Event Register 2

Register ETMCNTENR2 Details

| Field Name | Bits | Type | Reset Value | Description |
|-------------|------|------|-------------|--|
| Reserved_1 | 17 | ro | 0x1 | Reserved, RAO/WI |
| ExtOutEvent | 16:0 | rw | 0x0 | Count enable event. Subdivided as: Function, bits [16:14] Specifies the function that combines the two resources that define the event. Resource B, bits [13:7] and Resource A, bits [6:0] Specify the two resources that are combined by the logical operation specified by the Function field. |

Register ([ptm](#)) ETMCNTRLDEVR1

| | |
|------------------|--|
| Name | ETMCNTRLDEVR1 |
| Relative Address | 0x00000160 |
| Absolute Address | debug_cpu_ptm0: 0xF889C160 debug_cpu_ptm1: 0xF889D160 |
| Width | 17 bits |
| Access Type | rw |
| Reset Value | 0x00000000 |
| Description | Counter Reload Event Register 1 |

Register ETMCNTRLDEVR1 Details

| Field Name | Bits | Type | Reset Value | Description |
|----------------|------|------|-------------|--|
| CntReloadEvent | 16:0 | rw | 0x0 | Count reload event. Subdivided as: Function, bits [16:14] Specifies the function that combines the two resources that define the event. Resource B, bits [13:7] and Resource A, bits [6:0] Specify the two resources that are combined by the logical operation specified by the Function field. |

Register ([ptm](#)) ETMCNTRLDEVR2

| | |
|------------------|--|
| Name | ETMCNTRLDEVR2 |
| Relative Address | 0x00000164 |
| Absolute Address | debug_cpu_ptm0: 0xF889C164 debug_cpu_ptm1: 0xF889D164 |
| Width | 17 bits |

Access Type rw
 Reset Value 0x00000000
 Description Counter Reload Event Register 2

Register ETMCNTRLDEVR2 Details

| Field Name | Bits | Type | Reset Value | Description |
|----------------|------|------|-------------|--|
| CntReloadEvent | 16:0 | rw | 0x0 | Count reload event. Subdivided as: Function, bits [16:14] Specifies the function that combines the two resources that define the event. Resource B, bits [13:7] and Resource A, bits [6:0] Specify the two resources that are combined by the logical operation specified by the Function field. |

Register ([ptm](#)) ETMCNTR1

Name ETMCNTR1
 Relative Address 0x00000170
 Absolute Address debug_cpu_ptm0: 0xF889C170
 debug_cpu_ptm1: 0xF889D170
 Width 16 bits
 Access Type rw
 Reset Value 0x00000000
 Description Counter Value Register 1

Register ETMCNTR1 Details

| Field Name | Bits | Type | Reset Value | Description |
|------------|------|------|-------------|------------------------|
| CurrCount | 15:0 | rw | 0x0 | Current counter value. |

Register ([ptm](#)) ETMCNTR2

Name ETMCNTR2
 Relative Address 0x00000174
 Absolute Address debug_cpu_ptm0: 0xF889C174
 debug_cpu_ptm1: 0xF889D174
 Width 16 bits
 Access Type rw
 Reset Value 0x00000000

Description Counter Value Register 2

Register ETMCNTR2 Details

| Field Name | Bits | Type | Reset Value | Description |
|------------|------|------|-------------|------------------------|
| CurrCount | 15:0 | rw | 0x0 | Current counter value. |

Register ([ptm](#)) ETMSQ12EVR

Name ETMSQ12EVR
 Relative Address 0x00000180
 Absolute Address debug_cpu_ptm0: 0xF889C180
 debug_cpu_ptm1: 0xF889D180
 Width 17 bits
 Access Type rw
 Reset Value 0x00000000
 Description Sequencer State Transition Event Register 12

Register ETMSQ12EVR Details

| Field Name | Bits | Type | Reset Value | Description |
|------------|------|------|-------------|---|
| TransEvent | 16:0 | rw | 0x0 | A Sequencer State Transition Event Register, ETMSQmnEVR, defines the event that causes the sequencer state transition from state m to state n. The format is subdivided as: Function, bits [16:14] Specifies the function that combines the two resources that define the event. Resource B, bits [13:7] and Resource A, bits [6:0] Specify the two resources that are combined by the logical operation specified by the Function field. |

Register ([ptm](#)) ETMSQ21EVR

Name ETMSQ21EVR
 Relative Address 0x00000184
 Absolute Address debug_cpu_ptm0: 0xF889C184
 debug_cpu_ptm1: 0xF889D184
 Width 17 bits
 Access Type rw
 Reset Value 0x00000000

Description Sequencer State Transition Event Register 21

Register ETMSQ21EVR Details

| Field Name | Bits | Type | Reset Value | Description |
|------------|------|------|-------------|---|
| TransEvent | 16:0 | rw | 0x0 | A Sequencer State Transition Event Register, ETMSQmnEVR, defines the event that causes the sequencer state transition from state m to state n. The format is subdivided as: Function, bits [16:14] Specifies the function that combines the two resources that define the event. Resource B, bits [13:7] and Resource A, bits [6:0] Specify the two resources that are combined by the logical operation specified by the Function field. |

Register ([ptm](#)) ETMSQ23EVR

Name ETMSQ23EVR
 Relative Address 0x00000188
 Absolute Address debug_cpu_ptm0: 0xF889C188
 debug_cpu_ptm1: 0xF889D188
 Width 17 bits
 Access Type rw
 Reset Value 0x00000000
 Description Sequencer State Transition Event Register 23

Register ETMSQ23EVR Details

| Field Name | Bits | Type | Reset Value | Description |
|------------|------|------|-------------|---|
| TransEvent | 16:0 | rw | 0x0 | A Sequencer State Transition Event Register, ETMSQmnEVR, defines the event that causes the sequencer state transition from state m to state n. The format is subdivided as: Function, bits [16:14] Specifies the function that combines the two resources that define the event. Resource B, bits [13:7] and Resource A, bits [6:0] Specify the two resources that are combined by the logical operation specified by the Function field. |

Register ([ptm](#)) ETMSQ31EVR

| | |
|------------------|--|
| Name | ETMSQ31EVR |
| Relative Address | 0x0000018C |
| Absolute Address | debug_cpu_ptm0: 0xF889C18C debug_cpu_ptm1: 0xF889D18C |
| Width | 17 bits |
| Access Type | rw |
| Reset Value | 0x00000000 |
| Description | Sequencer State Transition Event Register 31 |

Register ETMSQ31EVR Details

| Field Name | Bits | Type | Reset Value | Description |
|------------|------|------|-------------|---|
| TransEvent | 16:0 | rw | 0x0 | A Sequencer State Transition Event Register, ETMSQmnEVR, defines the evnet that causes the sequencer state transition from state m to state n. The format is subdivided as: Function, bits [16:14] Specifies the function that combines the two resources that define the event. Resource B, bits [13:7] and Resource A, bits [6:0] Specify the two resources that are combined by the logical operation specified by the Function field. |

Register ([ptm](#)) ETMSQ32EVR

| | |
|------------------|--|
| Name | ETMSQ32EVR |
| Relative Address | 0x00000190 |
| Absolute Address | debug_cpu_ptm0: 0xF889C190 debug_cpu_ptm1: 0xF889D190 |
| Width | 17 bits |
| Access Type | rw |
| Reset Value | 0x00000000 |
| Description | Sequencer State Transition Event Register 32 |

Register ETMSQ32EVR Details

| Field Name | Bits | Type | Reset Value | Description |
|------------|------|------|-------------|---|
| TransEvent | 16:0 | rw | 0x0 | A Sequencer State Transition Event Register, ETMSQmnEVR, defines the evnet that causes the sequencer state transition from state m to state n. The format is subdivided as: Function, bits [16:14] Specifies the function that combines the two resources that define the event. Resource B, bits [13:7] and Resource A, bits [6:0] Specify the two resources that are combined by the logical operation specified by the Function field. |

Register ([ptm](#)) ETMSQ13EVR

| | |
|------------------|--|
| Name | ETMSQ13EVR |
| Relative Address | 0x00000194 |
| Absolute Address | debug_cpu_ptm0: 0xF889C194 debug_cpu_ptm1: 0xF889D194 |
| Width | 17 bits |
| Access Type | rw |
| Reset Value | 0x00000000 |
| Description | Sequencer State Transition Event Register 13 |

Register ETMSQ13EVR Details

| Field Name | Bits | Type | Reset Value | Description |
|------------|------|------|-------------|---|
| TransEvent | 16:0 | rw | 0x0 | A Sequencer State Transition Event Register, ETMSQmnEVR, defines the evnet that causes the sequencer state transition from state m to state n. The format is subdivided as: Function, bits [16:14] Specifies the function that combines the two resources that define the event. Resource B, bits [13:7] and Resource A, bits [6:0] Specify the two resources that are combined by the logical operation specified by the Function field. |

Register ([ptm](#)) ETMSQR

| | |
|------------------|------------|
| Name | ETMSQR |
| Relative Address | 0x0000019C |

Absolute Address debug_cpu_ptm0: 0xF889C19C
 debug_cpu_ptm1: 0xF889D19C

Width 2 bits

Access Type rw

Reset Value 0x00000000

Description Current Sequencer State Register

Register ETMSQR Details

| Field Name | Bits | Type | Reset Value | Description |
|-----------------|------|------|-------------|---------------------------------------|
| CurrentSeqState | 1:0 | rw | 0x0 | Indicates the current sequencer state |

Register ([ptm](#)) ETMEXTOUTEVR1

Name ETMEXTOUTEVR1

Relative Address 0x000001A0

Absolute Address debug_cpu_ptm0: 0xF889C1A0
 debug_cpu_ptm1: 0xF889D1A0

Width 17 bits

Access Type rw

Reset Value 0x00000000

Description External Output Event Register 1

Register ETMEXTOUTEVR1 Details

| Field Name | Bits | Type | Reset Value | Description |
|----------------|------|------|-------------|---|
| ExtOutputEvent | 16:0 | rw | 0x0 | External output event. Subdivided as: Function, bits [16:14] Specifies the function that combines the two resources that define the event. Resource B, bits [13:7] and Resource A, bits [6:0] Specify the two resources that are combined by the logical operation specified by the Function field. |

Register ([ptm](#)) ETMEXTOUTEVR2

Name ETMEXTOUTEVR2

Relative Address 0x000001A4

Absolute Address debug_cpu_ptm0: 0xF889C1A4
 debug_cpu_ptm1: 0xF889D1A4

Width 17 bits
 Access Type rw
 Reset Value 0x00000000
 Description External Output Event Register 2

Register ETMEXTOUTEVR2 Details

| Field Name | Bits | Type | Reset Value | Description |
|----------------|------|------|-------------|---|
| ExtOutputEvent | 16:0 | rw | 0x0 | External output event. Subdivided as: Function, bits [16:14] Specifies the function that combines the two resources that define the event. Resource B, bits [13:7] and Resource A, bits [6:0] Specify the two resources that are combined by the logical operation specified by the Function field. |

Register ([ptm](#)) ETMCIDCVR1

Name ETMCIDCVR1
 Relative Address 0x000001B0
 Absolute Address debug_cpu_ptm0: 0xF889C1B0
 debug_cpu_ptm1: 0xF889D1B0
 Width 32 bits
 Access Type rw
 Reset Value 0x00000000
 Description Context ID Comparator Value Register

Register ETMCIDCVR1 Details

| Field Name | Bits | Type | Reset Value | Description |
|------------|------|------|-------------|---------------------------------|
| ContextID | 31:0 | rw | 0x0 | Holds a 32-bit Context ID value |

Register ([ptm](#)) ETMCIDCMR

Name ETMCIDCMR
 Relative Address 0x000001BC
 Absolute Address debug_cpu_ptm0: 0xF889C1BC
 debug_cpu_ptm1: 0xF889D1BC
 Width 32 bits
 Access Type rw

Reset Value 0x00000000
 Description Context ID Comparator Mask Register

Register ETMCIDCMR Details

| Field Name | Bits | Type | Reset Value | Description |
|-------------|------|------|-------------|--------------------------------|
| ContextMask | 31:0 | rw | 0x0 | Holds a 32-bit Context ID mask |

Register ([ptm](#)) ETMSYNCFR

Name ETMSYNCFR
 Relative Address 0x000001E0
 Absolute Address debug_cpu_ptm0: 0xF889C1E0
 debug_cpu_ptm1: 0xF889D1E0
 Width 12 bits
 Access Type mixed
 Reset Value 0x00000400
 Description Synchronization Frequency Register

Register ETMSYNCFR Details

| Field Name | Bits | Type | Reset Value | Description |
|------------|------|------|-------------|---------------------------|
| SyncFreq | 11:2 | rw | 0x100 | Synchronization frequency |
| reserved | 1:0 | ro | 0x0 | Reserved |

Register ([ptm](#)) ETMIDR

Name ETMIDR
 Relative Address 0x000001E4
 Absolute Address debug_cpu_ptm0: 0xF889C1E4
 debug_cpu_ptm1: 0xF889D1E4
 Width 32 bits
 Access Type ro
 Reset Value 0x411CF301
 Description ID Register

Register ETMIDR Details

| Field Name | Bits | Type | Reset Value | Description |
|-------------|-------|------|-------------|---|
| ImplCode | 31:24 | ro | 0x41 | Implementor code. The field reads 0x41, ASCII code for A, indicating Arm Limited. |
| reserved | 23:21 | ro | 0x0 | Reserved |
| reserved | 20 | ro | 0x1 | Reserved, RAO |
| SecExtSupp | 19 | ro | 0x1 | Support for security extensions. |
| Thumb32Supp | 18 | ro | 0x1 | Support for 32-bit Thumb instructions. |
| reserved | 17:16 | ro | 0x0 | Reserved |
| Reserved_F | 15:12 | ro | 0xF | Reserved, 0b1111 |
| MajorVer | 11:8 | ro | 0x3 | Major architecture version number, 0b0011 |
| MinorVer | 7:4 | ro | 0x0 | Minor architecture version number, 0b0000 |
| ImplRev | 3:0 | ro | 0x1 | Implementation revision. |

Register ([ptm](#)) ETMCCER

| | |
|------------------|--|
| Name | ETMCCER |
| Relative Address | 0x000001E8 |
| Absolute Address | debug_cpu_ptm0: 0xF889C1E8 debug_cpu_ptm1: 0xF889D1E8 |
| Width | 26 bits |
| Access Type | ro |
| Reset Value | 0x000008EA |
| Description | Configuration Code Extension Register |

Register ETMCCER Details

| Field Name | Bits | Type | Reset Value | Description |
|------------|-------|------|-------------|---|
| BarrTS | 25 | ro | 0x0 | Timestamps are not generated for DMB/DSB |
| BarrWP | 24 | ro | 0x0 | DMB/DSB instructions are not treated as waypoints. |
| RetStack | 23 | ro | 0x0 | Return stack implemented. |
| Timestamp | 22 | ro | 0x0 | Timestamping implemented. |
| reserved | 21:16 | ro | 0x0 | Reserved |
| InstrumRes | 15:13 | ro | 0x0 | Specifies the number of instrumentation resources. |
| Reserved_1 | 12 | ro | 0x0 | Reserved, RAO |
| RegReads | 11 | ro | 0x1 | Indicates that all registers, except some Integration Test Registers, are readable. |

| Field Name | Bits | Type | Reset Value | Description |
|------------|------|------|-------------|---|
| ExtInSize | 10:3 | ro | 0x1D | Specifies the size of the extended external input bus, 29. |
| ExtInSel | 2:0 | ro | 0x2 | Specifies the number of extended external input selectors, 2. |

Register ([ptm](#)) ETMEXTINSELR

| | |
|------------------|--|
| Name | ETMEXTINSELR |
| Relative Address | 0x000001EC |
| Absolute Address | debug_cpu_ptm0: 0xF889C1EC debug_cpu_ptm1: 0xF889D1EC |
| Width | 14 bits |
| Access Type | rw |
| Reset Value | 0x00000000 |
| Description | Extended External Input Selection Register |

Register ETMEXTINSELR Details

| Field Name | Bits | Type | Reset Value | Description |
|------------|------|------|-------------|---|
| ExtInSel2 | 13:8 | rw | 0x0 | Second extended external input selector |
| reserved | 7:6 | rw | 0x0 | Reserved |
| ExtInSel1 | 5:0 | rw | 0x0 | First extended external input selector |

Register ([ptm](#)) ETMTSEVR

| | |
|------------------|--|
| Name | ETMTSEVR |
| Relative Address | 0x000001F8 |
| Absolute Address | debug_cpu_ptm0: 0xF889C1F8 debug_cpu_ptm1: 0xF889D1F8 |
| Width | 32 bits |
| Access Type | rw |
| Reset Value | 0x00000000 |
| Description | Timestamp Event |

Register ETMTSEVR Details

| Field Name | Bits | Type | Reset Value | Description |
|------------|-------|------|-------------|---|
| reserved | 31:17 | rw | 0x0 | reserved |
| Function | 16:14 | rw | 0x0 | Specifies the logical operation that combines the two resources that define the event. |
| ResourceB | 13:7 | rw | 0x0 | See [ResourceA] bit decription. |
| ResourceA | 6:0 | rw | 0x0 | Specify the two resources that are combined by the logical operation specified by the Function field. |

Register ([ptm](#)) ETMAUXCR

| | |
|------------------|--|
| Name | ETMAUXCR |
| Relative Address | 0x000001FC |
| Absolute Address | debug_cpu_ptm0: 0xF889C1FC debug_cpu_ptm1: 0xF889D1FC |
| Width | 4 bits |
| Access Type | rw |
| Reset Value | 0x00000000 |
| Description | Auxiliary Control Register |

Register ETMAUXCR Details

| Field Name | Bits | Type | Reset Value | Description |
|------------------|------|------|-------------|---|
| ForceSynInsert | 3 | rw | 0x0 | Force insertion of synchronization packets, regardless of current trace activity. Possible values for this bit are: b0 = Synchronization packets delayed when trace activity is high. This is the reset value. b1 = Synchronization packets inserted regardless of trace activity. This bit might be set if synchronization packets occur too far apart. Setting this bit might cause the trace FIFO to overflow more frequently when trace activity is high. |
| DisableWPUupdate | 2 | rw | 0x0 | Specifies whether the PTM issues waypoint update packets if there are more than 4096 bytes between waypoints. Possible values for this bit are: b0 = PTM always issues update packets if there are more than 4096 bytes between waypoints. This is the reset value. b1 = PTM does not issue waypoint update packets unless required to do so as the result of an exception or debug entry. |

| Field Name | Bits | Type | Reset Value | Description |
|-----------------|------|------|-------------|--|
| DisableTSOnBarr | 1 | rw | 0x0 | Specifies whether the PTM issues a timestamp on a barrier instruction. Possible values for this bit are: b0 = PTM issues timestamps on barrier instructions. This is the reset value. b1 = PTM does not issue timestamps on barriers |
| DisableForcedOF | 0 | rw | 0x0 | Specifies whether the PTM enters overflow state when synchronization is requested, and the previous synchronization sequence has not yet completed. This does not affect entry to overflow state when the FIFO becomes full. Possible values for this bit are: b0 = Forced overflow enabled. This is the reset value. b1 = Forced overflow disabled. |

Register ([ptm](#)) ETMTRACEIDR

| | |
|------------------|--|
| Name | ETMTRACEIDR |
| Relative Address | 0x00000200 |
| Absolute Address | debug_cpu_ptm0: 0xF889C200 debug_cpu_ptm1: 0xF889D200 |
| Width | 7 bits |
| Access Type | rw |
| Reset Value | 0x00000000 |
| Description | CoreSight Trace ID Register |

Register ETMTRACEIDR Details

| Field Name | Bits | Type | Reset Value | Description |
|------------|------|------|-------------|---|
| TraceID | 6:0 | rw | 0x0 | Before trace is generated, you must program this register with a non-reserved value. Reserved values are 0x00 and any value in the range 0x70-0x7F. The reset value of this register is 0x00. |

Register ([ptm](#)) OSLSR

| | |
|------------------|--|
| Name | OSLSR |
| Relative Address | 0x00000304 |
| Absolute Address | debug_cpu_ptm0: 0xF889C304 debug_cpu_ptm1: 0xF889D304 |
| Width | 32 bits |

Access Type ro
 Reset Value 0x00000000
 Description OS Lock Status Register

Register OLSR Details

| Field Name | Bits | Type | Reset Value | Description |
|------------|------|------|-------------|---|
| | 31:0 | ro | 0x0 | Shows that OS Locking is not implemented. |

Register ([ptm](#)) ETMPDSR

Name ETMPDSR
 Relative Address 0x00000314
 Absolute Address debug_cpu_ptm0: 0xF889C314
 debug_cpu_ptm1: 0xF889D314
 Width 32 bits
 Access Type ro
 Reset Value 0x00000001
 Description Device Powerdown Status Register

Register ETMPDSR Details

| Field Name | Bits | Type | Reset Value | Description |
|------------|------|------|-------------|---|
| | 31:0 | ro | 0x1 | Indicates that the PTM Trace Registers can be accessed. |

Register ([ptm](#)) ITMISCOUT

Name ITMISCOUT
 Relative Address 0x00000EDC
 Absolute Address debug_cpu_ptm0: 0xF889CEDC
 debug_cpu_ptm1: 0xF889DEDCE
 Width 10 bits
 Access Type wo
 Reset Value 0x00000000
 Description Miscellaneous Outputs Register

Register ITMISCOUT Details

| Field Name | Bits | Type | Reset Value | Description |
|------------|------|------|-------------|-----------------------------------|
| PTMEXTOUT | 9:8 | wo | 0x0 | Drives the PTMEXTOUT[1:0] outputs |
| reserved | 7:6 | wo | 0x0 | Reserved |
| PTMIDLEACK | 5 | wo | 0x0 | Drives the PTMIDLEACK output |
| PTMDBGREQ | 4 | wo | 0x0 | Drives the PTMDBGREQ output |
| reserved | 3:0 | wo | 0x0 | Reserved |

Register ([ptm](#)) ITMISCIN

| | |
|------------------|--|
| Name | ITMISCIN |
| Relative Address | 0x00000EE0 |
| Absolute Address | debug_cpu_ptm0: 0xF889CEE0 debug_cpu_ptm1: 0xF889DEE0 |
| Width | 7 bits |
| Access Type | ro |
| Reset Value | x |
| Description | Miscellaneous Inputs Register |

Register ITMISCIN Details

| Field Name | Bits | Type | Reset Value | Description |
|------------|------|------|-------------|--|
| STANDBYWFI | 6 | ro | x | Returns the value of the STANDBYWFI input |
| reserved | 5 | ro | 0x0 | Reserved |
| PTMDBGACK | 4 | ro | x | Returns the value of the PTMDBGACK input |
| EXTIN | 3:0 | ro | x | Returns the value of the EXTIN[3:0] inputs |

Register ([ptm](#)) ITTRIGGER

| | |
|------------------|--|
| Name | ITTRIGGER |
| Relative Address | 0x00000EE8 |
| Absolute Address | debug_cpu_ptm0: 0xF889CEE8 debug_cpu_ptm1: 0xF889DEE8 |
| Width | 1 bits |
| Access Type | wo |
| Reset Value | 0x00000000 |
| Description | Trigger Register |

Register ITTRIGGER Details

| Field Name | Bits | Type | Reset Value | Description |
|------------|------|------|-------------|------------------------------|
| PTMTRIGGER | 0 | wo | 0x0 | Drives the PTMTRIGGER output |

Register ([ptm](#)) ITATBDATA0

| | |
|------------------|--|
| Name | ITATBDATA0 |
| Relative Address | 0x0000EEC |
| Absolute Address | debug_cpu_ptm0: 0xF889CEEC debug_cpu_ptm1: 0xF889DEEC |
| Width | 5 bits |
| Access Type | wo |
| Reset Value | 0x00000000 |
| Description | ATB Data 0 Register |

Register ITATBDATA0 Details

| Field Name | Bits | Type | Reset Value | Description |
|------------|------|------|-------------|-------------------------------|
| ATDATAM31 | 4 | wo | 0x0 | Drives the ATDATAM[31] output |
| ATDATAM23 | 3 | wo | 0x0 | Drives the ATDATAM[23] output |
| ATDATAM15 | 2 | wo | 0x0 | Drives the ATDATAM[15] output |
| ATDATAM7 | 1 | wo | 0x0 | Drives the ATDATAM[7] output |
| ATDATAM0 | 0 | wo | 0x0 | Drives the ATDATAM[0] output |

Register ([ptm](#)) ITATBCTR2

| | |
|------------------|--|
| Name | ITATBCTR2 |
| Relative Address | 0x0000EF0 |
| Absolute Address | debug_cpu_ptm0: 0xF889CEF0 debug_cpu_ptm1: 0xF889DEF0 |
| Width | 2 bits |
| Access Type | ro |
| Reset Value | x |
| Description | ATB Control 2 Register |

Register ITATBCTR2 Details

| Field Name | Bits | Type | Reset Value | Description |
|------------|------|------|-------------|---|
| AFVALIDM | 1 | ro | x | Returns the value of the AFVALIDM input |
| ATREADYM | 0 | ro | x | Returns the value of the ATREADYM input |

Register ([ptm](#)) ITATBID

| | |
|------------------|--|
| Name | ITATBID |
| Relative Address | 0x00000EF4 |
| Absolute Address | debug_cpu_ptm0: 0xF889CEF4 debug_cpu_ptm1: 0xF889DEF4 |
| Width | 7 bits |
| Access Type | wo |
| Reset Value | 0x00000000 |
| Description | ATB Identification Register |

Register ITATBID Details

| Field Name | Bits | Type | Reset Value | Description |
|------------|------|------|-------------|-------------------------------|
| ATIDM | 6:0 | wo | 0x0 | Drives the ATIDM[6:0] outputs |

Register ([ptm](#)) ITATBCTR0

| | |
|------------------|--|
| Name | ITATBCTR0 |
| Relative Address | 0x00000EF8 |
| Absolute Address | debug_cpu_ptm0: 0xF889CEF8 debug_cpu_ptm1: 0xF889DEF8 |
| Width | 10 bits |
| Access Type | wo |
| Reset Value | 0x00000000 |
| Description | ATB Control 0 Register |

Register ITATBCTR0 Details

| Field Name | Bits | Type | Reset Value | Description |
|------------|------|------|-------------|----------------------------------|
| ATBYTESM | 9:8 | wo | 0x0 | Drives the ATBYTESM[9:8] outputs |
| reserved | 7:2 | wo | 0x0 | Reserved |

| Field Name | Bits | Type | Reset Value | Description |
|------------|------|------|-------------|----------------------------|
| AFREADYM | 1 | wo | 0x0 | Drives the AFREADYM output |
| ATVALIDM | 0 | wo | 0x0 | Drives the ATVALIDM output |

Register ([ptm](#)) ETMITCTRL

| | |
|------------------|--|
| Name | ETMITCTRL |
| Relative Address | 0x00000F00 |
| Absolute Address | debug_cpu_ptm0: 0xF889CF00 debug_cpu_ptm1: 0xF889DF00 |
| Width | 1 bits |
| Access Type | rw |
| Reset Value | 0x00000000 |
| Description | Integration Mode Control Register |

Register ETMITCTRL Details

| Field Name | Bits | Type | Reset Value | Description |
|------------|------|------|-------------|---|
| | 0 | rw | 0x0 | Enable Integration Test registers. Before entering integration mode, the PTM must be powered up and in programming mode. This means bit 0 of the Main Control Register is set to 0, and bit 10 of the Main Control Register is set 1. After leaving integration mode, the PTM must be reset before attempting to perform tracing. |

Register ([ptm](#)) CTSR

| | |
|------------------|--|
| Name | CTSR |
| Relative Address | 0x00000FA0 |
| Absolute Address | debug_cpu_ptm0: 0xF889CFA0 debug_cpu_ptm1: 0xF889DFA0 |
| Width | 8 bits |
| Access Type | rw |
| Reset Value | 0x000000FF |
| Description | Claim Tag Set Register |

Register CTSR Details

| Field Name | Bits | Type | Reset Value | Description |
|------------|------|------|-------------|---|
| | 7:0 | rw | 0xFF | The claim tag register is used for any interrogating tools to determine if the device is being programmed or has been programmed. Read: 1= Claim tag is implemented, 0 = Claim tag is not implemented Write: 1= Set claim tag bit, 0= No effect |

Register ([ptm](#)) CTCR

| | |
|------------------|--|
| Name | CTCR |
| Relative Address | 0x00000FA4 |
| Absolute Address | debug_cpu_ptm0: 0xF889CFA4 debug_cpu_ptm1: 0xF889DFA4 |
| Width | 8 bits |
| Access Type | rw |
| Reset Value | 0x00000000 |
| Description | Claim Tag Clear Register |

Register CTCR Details

| Field Name | Bits | Type | Reset Value | Description |
|------------|------|------|-------------|---|
| | 7:0 | rw | 0x0 | The claim tag register is used for any interrogating tools to determine if the device is being programmed or has been programmed. Read: Current value of claim tag. Write: 1= Clear claim tag bit, 0= No effect |

Register ([ptm](#)) LAR

| | |
|------------------|--|
| Name | LAR |
| Relative Address | 0x00000FB0 |
| Absolute Address | debug_cpu_ptm0: 0xF889CFB0 debug_cpu_ptm1: 0xF889DFB0 |
| Width | 32 bits |
| Access Type | wo |
| Reset Value | 0x00000000 |
| Description | Lock Access Register |

Register LAR Details

| Field Name | Bits | Type | Reset Value | Description |
|------------|------|------|-------------|---|
| | 31:0 | wo | 0x0 | <p>Write Access Code.</p> <p>Write behavior depends on PADDRDBG31 pin:</p> <ul style="list-style-type: none"> - PADDRDBG31=0 (lower 2GB): <p>After reset (via PRESETDBGn), PTM is locked, i.e., writes to all other registers using lower 2GB addresses are ignored.</p> <p>To unlock, 0xC5ACCE55 must be written this register.</p> <p>After the required registers are written, to lock again, write a value other than 0xC5ACCE55 to this register.</p> <ul style="list-style-type: none"> - PADDRDBG31=1 (upper 2GB): <p>PTM is unlocked when upper 2GB addresses are used to write to all the registers.</p> <p>However, write to this register is ignored using a upper 2GB address!</p> <p>Note: read from this register always returns 0, regardless of PADDRDBG31.</p> |

Register ([ptm](#)) LSR

| | |
|------------------|--|
| Name | LSR |
| Relative Address | 0x00000FB4 |
| Absolute Address | debug_cpu_ptm0: 0xF889CFB4 debug_cpu_ptm1: 0xF889DFB4 |
| Width | 3 bits |
| Access Type | ro |
| Reset Value | 0x00000003 |
| Description | Lock Status Register |

Register LSR Details

| Field Name | Bits | Type | Reset Value | Description |
|------------|------|------|-------------|---|
| 8BIT | 2 | ro | 0x0 | Set to 0 since PTM implements a 32-bit lock access register |

| Field Name | Bits | Type | Reset Value | Description |
|------------|------|------|-------------|--|
| STATUS | 1 | ro | 0x1 | Read behavior depends on PADDRDBG31 pin: - PADDRDBG31=0 (lower 2GB): When a lower 2GB address is used to read this register, this bit indicates whether PTM is in locked state (1= locked, 0= unlocked). - PADDRDBG31=1 (upper 2GB): always returns 0. |
| IMP | 0 | ro | 0x1 | Read behavior depends on PADDRDBG31 pin: - PADDRDBG31=0 (lower 2GB): always returns 1, meaning lock mechanism are implemented. - PADDRDBG31=1 (upper 2GB): always returns 0, meaning lock mechanism is NOT implemented. |

Register ([ptm](#)) ASR

| | |
|------------------|--|
| Name | ASR |
| Relative Address | 0x00000FB8 |
| Absolute Address | debug_cpu_ptm0: 0xF889CFB8 debug_cpu_ptm1: 0xF889DFB8 |
| Width | 8 bits |
| Access Type | ro |
| Reset Value | x |
| Description | Authentication Status Register |

Register ASR Details

| Field Name | Bits | Type | Reset Value | Description |
|------------|------|------|-------------|---|
| SNI | 7:6 | ro | 0x0 | Secure non-invasive debug Always 2'b00, This functionality is not implemented |
| SI | 5:4 | ro | 0x0 | Secure invasive debug Always 2'b00. This functionality is not implemented. |

| Field Name | Bits | Type | Reset Value | Description |
|------------|------|------|-------------|---|
| NSNI | 3:2 | ro | x | Non-secure non-invasive debug IF NIDEN or DBGEN is 1, this field is 2'b11, indicating the functionality is implemented and enabled. Otherwise, this field is 2'b10 (implemented but disabled) |
| NSI | 1:0 | ro | 0x0 | Non-secure invasive debug Always 2'b00. This functionality is not implemented. |

Register ([ptm](#)) DEVID

| | |
|------------------|--|
| Name | DEVID |
| Relative Address | 0x00000FC8 |
| Absolute Address | debug_cpu_ptm0: 0xF889CFC8 debug_cpu_ptm1: 0xF889DFC8 |
| Width | 32 bits |
| Access Type | ro |
| Reset Value | 0x00000000 |
| Description | Device ID |

Register DEVID Details

| Field Name | Bits | Type | Reset Value | Description |
|------------|------|------|-------------|----------------------|
| | 31:0 | ro | 0x0 | Component capability |

Register ([ptm](#)) DTIR

| | |
|------------------|--|
| Name | DTIR |
| Relative Address | 0x00000FCC |
| Absolute Address | debug_cpu_ptm0: 0xF889CFCC debug_cpu_ptm1: 0xF889DFCC |
| Width | 32 bits |
| Access Type | ro |
| Reset Value | 0x00000013 |
| Description | Device Type Identifier (ETMDEVTYPE) |

Register DTIR Details

See CoreSight PTM-A9 Technical Reference Manual and CoreSight Program Flow Trace Architecture Specification for more information.

| Field Name | Bits | Type | Reset Value | Description |
|------------|------|------|-------------|------------------------------------|
| TRACE | 31:8 | ro | 0x0 | A trace source and processor trace |
| SUBTYPE | 7:4 | ro | 0x1 | Sub type, 0x1, processor trace |
| MAINTYPE | 3:0 | ro | 0x3 | Main type, 0x3, trace source |

Register ([ptm](#)) PERIPHID4

| | |
|------------------|--|
| Name | PERIPHID4 |
| Relative Address | 0x00000FD0 |
| Absolute Address | debug_cpu_ptm0: 0xF889CFD0 debug_cpu_ptm1: 0xF889DFD0 |
| Width | 8 bits |
| Access Type | ro |
| Reset Value | 0x00000004 |
| Description | Peripheral ID4 |

Register PERIPHID4 Details

| Field Name | Bits | Type | Reset Value | Description |
|------------|------|------|-------------|--------------------------|
| 4KB_count | 7:4 | ro | 0x0 | 4KB Count, set to 0 |
| JEP106ID | 3:0 | ro | 0x4 | JEP106 continuation code |

Register ([ptm](#)) PERIPHID5

| | |
|------------------|--|
| Name | PERIPHID5 |
| Relative Address | 0x00000FD4 |
| Absolute Address | debug_cpu_ptm0: 0xF889CFD4 debug_cpu_ptm1: 0xF889DFD4 |
| Width | 8 bits |
| Access Type | ro |
| Reset Value | 0x00000000 |
| Description | Peripheral ID5 |

Register PERIPHID5 Details

| Field Name | Bits | Type | Reset Value | Description |
|------------|------|------|-------------|-------------|
| | 7:0 | ro | 0x0 | reserved |

Register ([ptm](#)) PERIPHID6

| | |
|------------------|--|
| Name | PERIPHID6 |
| Relative Address | 0x00000FD8 |
| Absolute Address | debug_cpu_ptm0: 0xF889CFD8 debug_cpu_ptm1: 0xF889DFD8 |
| Width | 8 bits |
| Access Type | ro |
| Reset Value | 0x00000000 |
| Description | Peripheral ID6 |

Register PERIPHID6 Details

| Field Name | Bits | Type | Reset Value | Description |
|------------|------|------|-------------|-------------|
| | 7:0 | ro | 0x0 | reserved |

Register ([ptm](#)) PERIPHID7

| | |
|------------------|--|
| Name | PERIPHID7 |
| Relative Address | 0x00000FDC |
| Absolute Address | debug_cpu_ptm0: 0xF889CFDC debug_cpu_ptm1: 0xF889DFDC |
| Width | 8 bits |
| Access Type | ro |
| Reset Value | 0x00000000 |
| Description | Peripheral ID7 |

Register PERIPHID7 Details

| Field Name | Bits | Type | Reset Value | Description |
|------------|------|------|-------------|-------------|
| | 7:0 | ro | 0x0 | reserved |

Register ([ptm](#)) PERIPHID0

| | |
|------------------|--|
| Name | PERIPHID0 |
| Relative Address | 0x00000FE0 |
| Absolute Address | debug_cpu_ptm0: 0xF889CFE0 debug_cpu_ptm1: 0xF889DFE0 |
| Width | 8 bits |
| Access Type | ro |

Reset Value 0x00000050
 Description Peripheral ID0

Register PERIPHID0 Details

| Field Name | Bits | Type | Reset Value | Description |
|------------|------|------|-------------|-------------|
| | 7:0 | ro | 0x50 | PartNumber0 |

Register ([ptm](#)) PERIPHID1

Name PERIPHID1
 Relative Address 0x00000FE4
 Absolute Address debug_cpu_ptm0: 0xF889CFE4
 debug_cpu_ptm1: 0xF889DFE4
 Width 8 bits
 Access Type ro
 Reset Value 0x000000B9
 Description Peripheral ID1

Register PERIPHID1 Details

| Field Name | Bits | Type | Reset Value | Description |
|-------------|------|------|-------------|----------------------------|
| JEP106ID | 7:4 | ro | 0xB | JEP106 Identity Code [3:0] |
| PartNumber1 | 3:0 | ro | 0x9 | PartNumber1 |

Register ([ptm](#)) PERIPHID2

Name PERIPHID2
 Relative Address 0x00000FE8
 Absolute Address debug_cpu_ptm0: 0xF889CFE8
 debug_cpu_ptm1: 0xF889DFE8
 Width 8 bits
 Access Type ro
 Reset Value 0x0000001B
 Description Peripheral ID2

Register PERIPHID2 Details

| Field Name | Bits | Type | Reset Value | Description |
|------------|------|------|-------------|---|
| RevNum | 7:4 | ro | 0x1 | Revision number of Peripheral |
| JEDEC | 3 | ro | 0x1 | Indicates that a JEDEC assigned value is used |
| JEP106ID | 2:0 | ro | 0x3 | JEP106 Identity Code [6:4] |

Register ([ptm](#)) PERIPHID3

| | |
|------------------|--|
| Name | PERIPHID3 |
| Relative Address | 0x00000FEC |
| Absolute Address | debug_cpu_ptm0: 0xF889CFEC debug_cpu_ptm1: 0xF889DFEC |
| Width | 8 bits |
| Access Type | ro |
| Reset Value | 0x00000000 |
| Description | Peripheral ID3 |

Register PERIPHID3 Details

| Field Name | Bits | Type | Reset Value | Description |
|------------|------|------|-------------|----------------------|
| RevAnd | 7:4 | ro | 0x0 | RevAnd, at top level |
| CustMod | 3:0 | ro | 0x0 | Customer Modified |

Register ([ptm](#)) COMPID0

| | |
|------------------|--|
| Name | COMPID0 |
| Relative Address | 0x00000FF0 |
| Absolute Address | debug_cpu_ptm0: 0xF889CFF0 debug_cpu_ptm1: 0xF889DFF0 |
| Width | 8 bits |
| Access Type | ro |
| Reset Value | 0x0000000D |
| Description | Component ID0 |

Register COMPID0 Details

| Field Name | Bits | Type | Reset Value | Description |
|------------|------|------|-------------|-------------|
| | 7:0 | ro | 0xD | Preamble |

Register ([ptm](#)) COMPID1

| | |
|------------------|--|
| Name | COMPID1 |
| Relative Address | 0x00000FF4 |
| Absolute Address | debug_cpu_ptm0: 0xF889CFF4 debug_cpu_ptm1: 0xF889DFF4 |
| Width | 8 bits |
| Access Type | ro |
| Reset Value | 0x00000090 |
| Description | Component ID1 |

Register COMPID1 Details

| Field Name | Bits | Type | Reset Value | Description |
|------------|------|------|-------------|-------------|
| | 7:0 | ro | 0x90 | Preamble |

Register ([ptm](#)) COMPID2

| | |
|------------------|--|
| Name | COMPID2 |
| Relative Address | 0x00000FF8 |
| Absolute Address | debug_cpu_ptm0: 0xF889CFF8 debug_cpu_ptm1: 0xF889DFF8 |
| Width | 8 bits |
| Access Type | ro |
| Reset Value | 0x00000005 |
| Description | Component ID2 |

Register COMPID2 Details

| Field Name | Bits | Type | Reset Value | Description |
|------------|------|------|-------------|-------------|
| | 7:0 | ro | 0x5 | Preamble |

Register ([ptm](#)) COMPID3

| | |
|------------------|--|
| Name | COMPID3 |
| Relative Address | 0x00000FFC |
| Absolute Address | debug_cpu_ptm0: 0xF889CFFC debug_cpu_ptm1: 0xF889DFFC |
| Width | 8 bits |
| Access Type | ro |

Reset Value 0x000000B1
 Description Component ID3

Register COMPID3 Details

| Field Name | Bits | Type | Reset Value | Description |
|------------|------|------|-------------|-------------|
| | 7:0 | ro | 0xB1 | Preamble |

B.10 Debug Access Port (dap)

Module Name Debug Access Port (dap)
 Base Address 0xF8800000 debug_dap_rom
 Description Debug Access Port ROM Table
 Vendor Info

Register Summary

| Register Name | Address | Width | Type | Reset Value | Description |
|----------------------------|------------|-------|------|-------------|----------------|
| ROMENTRY00 | 0x00000000 | 32 | ro | 0x00001003 | ROM entry 00 |
| ROMENTRY01 | 0x00000004 | 32 | ro | 0x00002003 | ROM entry 01 |
| ROMENTRY02 | 0x00000008 | 32 | ro | 0x00003003 | ROM entry 02 |
| ROMENTRY03 | 0x0000000C | 32 | ro | 0x00004003 | ROM entry 03 |
| ROMENTRY04 | 0x00000010 | 32 | ro | 0x00005003 | ROM entry 04 |
| ROMENTRY05 | 0x00000014 | 32 | ro | 0x00009003 | ROM entry 05 |
| ROMENTRY06 | 0x00000018 | 32 | ro | 0x0000A003 | ROM entry 06 |
| ROMENTRY07 | 0x0000001C | 32 | ro | 0x0000B003 | ROM entry 07 |
| ROMENTRY08 | 0x00000020 | 32 | ro | 0x0000C003 | ROM entry 08 |
| ROMENTRY09 | 0x00000024 | 32 | ro | 0x00080003 | ROM entry 09 |
| ROMENTRY10 | 0x00000028 | 32 | rw | 0x00000000 | ROM entry 10 |
| ROMENTRY11 | 0x0000002C | 32 | rw | 0x00000000 | ROM entry 11 |
| ROMENTRY12 | 0x00000030 | 32 | rw | 0x00000000 | ROM entry 12 |
| ROMENTRY13 | 0x00000034 | 32 | rw | 0x00000000 | ROM entry 13 |
| ROMENTRY14 | 0x00000038 | 32 | rw | 0x00000000 | ROM entry 14 |
| ROMENTRY15 | 0x0000003C | 32 | rw | 0x00000000 | ROM entry 15 |
| PERIPHID4 | 0x0000FD0 | 8 | ro | 0x00000003 | Peripheral ID4 |
| PERIPHID5 | 0x0000FD4 | 8 | ro | 0x00000000 | Peripheral ID5 |
| PERIPHID6 | 0x0000FD8 | 8 | ro | 0x00000000 | Peripheral ID6 |
| PERIPHID7 | 0x0000FDC | 8 | ro | 0x00000000 | Peripheral ID7 |
| PERIPHID0 | 0x0000FE0 | 8 | ro | 0x000000B2 | Peripheral ID0 |
| PERIPHID1 | 0x0000FE4 | 8 | ro | 0x00000093 | Peripheral ID1 |
| PERIPHID2 | 0x0000FE8 | 8 | ro | 0x00000028 | Peripheral ID2 |
| PERIPHID3 | 0x0000FEC | 8 | ro | 0x00000007 | Peripheral ID3 |
| COMPID0 | 0x0000FF0 | 8 | ro | 0x0000000D | Component ID0 |
| COMPID1 | 0x0000FF4 | 8 | ro | 0x00000010 | Component ID1 |

| Register Name | Address | Width | Type | Reset Value | Description |
|-------------------------|------------|-------|------|-------------|---------------|
| COMPID2 | 0x00000FF8 | 8 | ro | 0x00000005 | Component ID2 |
| COMPID3 | 0x00000FFC | 8 | ro | 0x000000B1 | Component ID3 |

Register ([dap](#)) ROMENTRY00

| | |
|------------------|--------------|
| Name | ROMENTRY00 |
| Relative Address | 0x00000000 |
| Absolute Address | 0xF8800000 |
| Width | 32 bits |
| Access Type | ro |
| Reset Value | 0x00001003 |
| Description | ROM entry 00 |

Register ROMENTRY00 Details

| Field Name | Bits | Type | Reset Value | Description |
|---------------|-------|------|-------------|--|
| AddressOffset | 31:12 | ro | 0x1 | Base address of the component, relative to the ROM address. Negative values are permitted using two's complement. ComponentAddress = ROMAddress + (AddressOffset SHL 12) |
| reserved | 11:2 | ro | 0x0 | Reserved |
| Format | 1 | ro | 0x1 | Format of ROM entry Enumerated Value List: 32BIT=1. 8BIT=0. |
| EntryPresent | 0 | ro | 0x1 | Set HIGH to indicate an entry is present. |

Register ([dap](#)) ROMENTRY01

| | |
|------------------|--------------|
| Name | ROMENTRY01 |
| Relative Address | 0x00000004 |
| Absolute Address | 0xF8800004 |
| Width | 32 bits |
| Access Type | ro |
| Reset Value | 0x00002003 |
| Description | ROM entry 01 |

Register ROMENTRY01 Details

| Field Name | Bits | Type | Reset Value | Description |
|---------------|-------|------|-------------|--|
| AddressOffset | 31:12 | ro | 0x2 | Base address of the component, relative to the ROM address. Negative values are permitted using two's complement. ComponentAddress = ROMAddress + (AddressOffset SHL 12) |
| reserved | 11:2 | ro | 0x0 | Reserved |
| Format | 1 | ro | 0x1 | Format of ROM entry Enumerated Value List: 32BIT=1. 8BIT=0. |
| EntryPresent | 0 | ro | 0x1 | Set HIGH to indicate an entry is present. |

Register ([dap](#)) ROMENTRY02

| | |
|------------------|--------------|
| Name | ROMENTRY02 |
| Relative Address | 0x00000008 |
| Absolute Address | 0xF8800008 |
| Width | 32 bits |
| Access Type | ro |
| Reset Value | 0x00003003 |
| Description | ROM entry 02 |

Register ROMENTRY02 Details

| Field Name | Bits | Type | Reset Value | Description |
|---------------|-------|------|-------------|--|
| AddressOffset | 31:12 | ro | 0x3 | Base address of the component, relative to the ROM address. Negative values are permitted using two's complement. ComponentAddress = ROMAddress + (AddressOffset SHL 12) |
| reserved | 11:2 | ro | 0x0 | Reserved |
| Format | 1 | ro | 0x1 | Format of ROM entry Enumerated Value List: 32BIT=1. 8BIT=0. |
| EntryPresent | 0 | ro | 0x1 | Set HIGH to indicate an entry is present. |

Register ([dap](#)) ROMENTRY03

Name ROMENTRY03
 Relative Address 0x0000000C
 Absolute Address 0xF880000C
 Width 32 bits
 Access Type ro
 Reset Value 0x00004003
 Description ROM entry 03

Register ROMENTRY03 Details

| Field Name | Bits | Type | Reset Value | Description |
|---------------|-------|------|-------------|--|
| AddressOffset | 31:12 | ro | 0x4 | Base address of the component, relative to the ROM address. Negative values are permitted using two's complement. ComponentAddress = ROMAddress + (AddressOffset SHL 12) |
| reserved | 11:2 | ro | 0x0 | Reserved |
| Format | 1 | ro | 0x1 | Format of ROM entry Enumerated Value List: 32BIT=1. 8BIT=0. |
| EntryPresent | 0 | ro | 0x1 | Set HIGH to indicate an entry is present. |

Register ([dap](#)) ROMENTRY04

Name ROMENTRY04
 Relative Address 0x00000010
 Absolute Address 0xF8800010
 Width 32 bits
 Access Type ro
 Reset Value 0x00005003
 Description ROM entry 04

Register ROMENTRY04 Details

| Field Name | Bits | Type | Reset Value | Description |
|---------------|-------|------|-------------|--|
| AddressOffset | 31:12 | ro | 0x5 | Base address of the component, relative to the ROM address. Negative values are permitted using two's complement. ComponentAddress = ROMAddress + (AddressOffset SHL 12) |
| reserved | 11:2 | ro | 0x0 | Reserved |
| Format | 1 | ro | 0x1 | Format of ROM entry Enumerated Value List: 32BIT=1. 8BIT=0. |
| EntryPresent | 0 | ro | 0x1 | Set HIGH to indicate an entry is present. |

Register ([dap](#)) ROMENTRY05

| | |
|------------------|--------------|
| Name | ROMENTRY05 |
| Relative Address | 0x00000014 |
| Absolute Address | 0xF8800014 |
| Width | 32 bits |
| Access Type | ro |
| Reset Value | 0x00009003 |
| Description | ROM entry 05 |

Register ROMENTRY05 Details

| Field Name | Bits | Type | Reset Value | Description |
|---------------|-------|------|-------------|--|
| AddressOffset | 31:12 | ro | 0x9 | Base address of the component, relative to the ROM address. Negative values are permitted using two's complement. ComponentAddress = ROMAddress + (AddressOffset SHL 12) |
| reserved | 11:2 | ro | 0x0 | Reserved |
| Format | 1 | ro | 0x1 | Format of ROM entry Enumerated Value List: 32BIT=1. 8BIT=0. |
| EntryPresent | 0 | ro | 0x1 | Set HIGH to indicate an entry is present. |

Register ([dap](#)) ROMENTRY06

Name ROMENTRY06
 Relative Address 0x00000018
 Absolute Address 0xF8800018
 Width 32 bits
 Access Type ro
 Reset Value 0x0000A003
 Description ROM entry 06

Register ROMENTRY06 Details

| Field Name | Bits | Type | Reset Value | Description |
|---------------|-------|------|-------------|--|
| AddressOffset | 31:12 | ro | 0xA | Base address of the component, relative to the ROM address. Negative values are permitted using two's complement. ComponentAddress = ROMAddress + (AddressOffset SHL 12) |
| reserved | 11:2 | ro | 0x0 | Reserved |
| Format | 1 | ro | 0x1 | Format of ROM entry Enumerated Value List: 32BIT=1. 8BIT=0. |
| EntryPresent | 0 | ro | 0x1 | Set HIGH to indicate an entry is present. |

Register ([dap](#)) ROMENTRY07

Name ROMENTRY07
 Relative Address 0x0000001C
 Absolute Address 0xF880001C
 Width 32 bits
 Access Type ro
 Reset Value 0x0000B003
 Description ROM entry 07

Register ROMENTRY07 Details

| Field Name | Bits | Type | Reset Value | Description |
|---------------|-------|------|-------------|--|
| AddressOffset | 31:12 | ro | 0xB | Base address of the component, relative to the ROM address. Negative values are permitted using two's complement. ComponentAddress = ROMAddress + (AddressOffset SHL 12) |
| reserved | 11:2 | ro | 0x0 | Reserved |
| Format | 1 | ro | 0x1 | Format of ROM entry Enumerated Value List: 32BIT=1. 8BIT=0. |
| EntryPresent | 0 | ro | 0x1 | Set HIGH to indicate an entry is present. |

Register (dap) ROMENTRY08

| | |
|------------------|--------------|
| Name | ROMENTRY08 |
| Relative Address | 0x00000020 |
| Absolute Address | 0xF8800020 |
| Width | 32 bits |
| Access Type | ro |
| Reset Value | 0x0000C003 |
| Description | ROM entry 08 |

Register ROMENTRY08 Details

| Field Name | Bits | Type | Reset Value | Description |
|---------------|-------|------|-------------|--|
| AddressOffset | 31:12 | ro | 0xC | Base address of the component, relative to the ROM address. Negative values are permitted using two's complement. ComponentAddress = ROMAddress + (AddressOffset SHL 12) |
| reserved | 11:2 | ro | 0x0 | Reserved |
| Format | 1 | ro | 0x1 | Format of ROM entry Enumerated Value List: 32BIT=1. 8BIT=0. |
| EntryPresent | 0 | ro | 0x1 | Set HIGH to indicate an entry is present. |

Register ([dap](#)) ROMENTRY09

Name ROMENTRY09
 Relative Address 0x00000024
 Absolute Address 0xF8800024
 Width 32 bits
 Access Type ro
 Reset Value 0x00080003
 Description ROM entry 09

Register ROMENTRY09 Details

| Field Name | Bits | Type | Reset Value | Description |
|---------------|-------|------|-------------|--|
| AddressOffset | 31:12 | ro | 0x80 | Base address of the component, relative to the ROM address. Negative values are permitted using two's complement. ComponentAddress = ROMAddress + (AddressOffset SHL 12) |
| reserved | 11:2 | ro | 0x0 | Reserved |
| Format | 1 | ro | 0x1 | Format of ROM entry Enumerated Value List: 32BIT=1. 8BIT=0. |
| EntryPresent | 0 | ro | 0x1 | Set HIGH to indicate an entry is present. |

Register ([dap](#)) ROMENTRY10

Name ROMENTRY10
 Relative Address 0x00000028
 Absolute Address 0xF8800028
 Width 32 bits
 Access Type rw
 Reset Value 0x00000000
 Description ROM entry 10

Register ROMENTRY10 Details

| Field Name | Bits | Type | Reset Value | Description |
|------------|------|------|-------------|---------------|
| | 31:0 | rw | 0x0 | Invalid entry |

Register ([dap](#)) ROMENTRY11

Name ROMENTRY11
 Relative Address 0x0000002C
 Absolute Address 0xF880002C
 Width 32 bits
 Access Type rw
 Reset Value 0x00000000
 Description ROM entry 11

Register ROMENTRY11 Details

| Field Name | Bits | Type | Reset Value | Description |
|------------|------|------|-------------|---------------|
| | 31:0 | rw | 0x0 | Invalid entry |

Register ([dap](#)) ROMENTRY12

Name ROMENTRY12
 Relative Address 0x00000030
 Absolute Address 0xF8800030
 Width 32 bits
 Access Type rw
 Reset Value 0x00000000
 Description ROM entry 12

Register ROMENTRY12 Details

| Field Name | Bits | Type | Reset Value | Description |
|------------|------|------|-------------|---------------|
| | 31:0 | rw | 0x0 | Invalid entry |

Register ([dap](#)) ROMENTRY13

Name ROMENTRY13
 Relative Address 0x00000034
 Absolute Address 0xF8800034
 Width 32 bits
 Access Type rw
 Reset Value 0x00000000
 Description ROM entry 13

Register ROMENTRY13 Details

| Field Name | Bits | Type | Reset Value | Description |
|------------|------|------|-------------|---------------|
| | 31:0 | rw | 0x0 | Invalid entry |

Register ([dap](#)) ROMENTRY14

| | |
|------------------|--------------|
| Name | ROMENTRY14 |
| Relative Address | 0x00000038 |
| Absolute Address | 0xF8800038 |
| Width | 32 bits |
| Access Type | rw |
| Reset Value | 0x00000000 |
| Description | ROM entry 14 |

Register ROMENTRY14 Details

| Field Name | Bits | Type | Reset Value | Description |
|------------|------|------|-------------|---------------|
| | 31:0 | rw | 0x0 | Invalid entry |

Register ([dap](#)) ROMENTRY15

| | |
|------------------|--------------|
| Name | ROMENTRY15 |
| Relative Address | 0x0000003C |
| Absolute Address | 0xF880003C |
| Width | 32 bits |
| Access Type | rw |
| Reset Value | 0x00000000 |
| Description | ROM entry 15 |

Register ROMENTRY15 Details

| Field Name | Bits | Type | Reset Value | Description |
|------------|------|------|-------------|---------------|
| | 31:0 | rw | 0x0 | Invalid entry |

Register ([dap](#)) PERIPHID4

| | |
|------------------|------------|
| Name | PERIPHID4 |
| Relative Address | 0x00000FD0 |

Absolute Address 0xF8800FD0
 Width 8 bits
 Access Type ro
 Reset Value 0x00000003
 Description Peripheral ID4

Register PERIPHID4 Details

| Field Name | Bits | Type | Reset Value | Description |
|------------|------|------|-------------|--------------------------|
| 4KB_count | 7:4 | ro | 0x0 | 4KB Count, set to 0 |
| | 3:0 | ro | 0x3 | JEP106 continuation code |

Register ([dap](#)) PERIPHID5

Name PERIPHID5
 Relative Address 0x00000FD4
 Absolute Address 0xF8800FD4
 Width 8 bits
 Access Type ro
 Reset Value 0x00000000
 Description Peripheral ID5

Register PERIPHID5 Details

| Field Name | Bits | Type | Reset Value | Description |
|------------|------|------|-------------|-------------|
| reserved | 7:0 | ro | 0x0 | Reserved |

Register ([dap](#)) PERIPHID6

Name PERIPHID6
 Relative Address 0x00000FD8
 Absolute Address 0xF8800FD8
 Width 8 bits
 Access Type ro
 Reset Value 0x00000000
 Description Peripheral ID6

Register PERIPHID6 Details

| Field Name | Bits | Type | Reset Value | Description |
|------------|------|------|-------------|-------------|
| reserved | 7:0 | ro | 0x0 | Reserved |

Register ([dap](#)) PERIPHID7

| | |
|------------------|----------------|
| Name | PERIPHID7 |
| Relative Address | 0x00000FDC |
| Absolute Address | 0xF8800FDC |
| Width | 8 bits |
| Access Type | ro |
| Reset Value | 0x00000000 |
| Description | Peripheral ID7 |

Register PERIPHID7 Details

| Field Name | Bits | Type | Reset Value | Description |
|------------|------|------|-------------|-------------|
| reserved | 7:0 | ro | 0x0 | Reserved |

Register ([dap](#)) PERIPHID0

| | |
|------------------|----------------|
| Name | PERIPHID0 |
| Relative Address | 0x00000FE0 |
| Absolute Address | 0xF8800FE0 |
| Width | 8 bits |
| Access Type | ro |
| Reset Value | 0x000000B2 |
| Description | Peripheral ID0 |

Register PERIPHID0 Details

| Field Name | Bits | Type | Reset Value | Description |
|-------------|------|------|-------------|-------------|
| PartNumber0 | 7:0 | ro | 0xB2 | PartNumber0 |

Register ([dap](#)) PERIPHID1

| | |
|------------------|------------|
| Name | PERIPHID1 |
| Relative Address | 0x00000FE4 |

Absolute Address 0xF8800FE4
 Width 8 bits
 Access Type ro
 Reset Value 0x00000093
 Description Peripheral ID1

Register PERIPID1 Details

| Field Name | Bits | Type | Reset Value | Description |
|-------------|------|------|-------------|----------------------------|
| JEP106ID | 7:4 | ro | 0x9 | JEP106 Identity Code [3:0] |
| PartNumber1 | 3:0 | ro | 0x3 | PartNumber1 |

Register ([dap](#)) PERIPID2

Name PERIPID2
 Relative Address 0x00000FE8
 Absolute Address 0xF8800FE8
 Width 8 bits
 Access Type ro
 Reset Value 0x00000028
 Description Peripheral ID2

Register PERIPID2 Details

| Field Name | Bits | Type | Reset Value | Description |
|------------|------|------|-------------|---|
| RevNum | 7:4 | ro | 0x2 | Revision number of Peripheral |
| JEDEC | 3 | ro | 0x1 | Indicates that a JEDEC assigned value is used |
| JEP106ID | 2:0 | ro | 0x0 | JEP106 Identity Code [6:4] |

Register ([dap](#)) PERIPID3

Name PERIPID3
 Relative Address 0x00000FEC
 Absolute Address 0xF8800FEC
 Width 8 bits
 Access Type ro
 Reset Value 0x00000007
 Description Peripheral ID3

Register PERIPHID3 Details

| Field Name | Bits | Type | Reset Value | Description |
|------------|------|------|-------------|----------------------|
| RevAnd | 7:4 | ro | 0x0 | RevAnd, at top level |
| CustMod | 3:0 | ro | 0x7 | Customer Modified |

Register ([dap](#)) COMPID0

| | |
|------------------|---------------|
| Name | COMPID0 |
| Relative Address | 0x00000FF0 |
| Absolute Address | 0xF8800FF0 |
| Width | 8 bits |
| Access Type | ro |
| Reset Value | 0x0000000D |
| Description | Component ID0 |

Register COMPID0 Details

| Field Name | Bits | Type | Reset Value | Description |
|------------|------|------|-------------|-------------|
| Preamble | 7:0 | ro | 0xD | Preamble |

Register ([dap](#)) COMPID1

| | |
|------------------|---------------|
| Name | COMPID1 |
| Relative Address | 0x00000FF4 |
| Absolute Address | 0xF8800FF4 |
| Width | 8 bits |
| Access Type | ro |
| Reset Value | 0x00000010 |
| Description | Component ID1 |

Register COMPID1 Details

| Field Name | Bits | Type | Reset Value | Description |
|------------|------|------|-------------|-------------|
| Preamble | 7:0 | ro | 0x10 | Preamble |

Register ([dap](#)) COMPID2

| | |
|------|---------|
| Name | COMPID2 |
|------|---------|

Relative Address 0x0000FF8
 Absolute Address 0xF880FF8
 Width 8 bits
 Access Type ro
 Reset Value 0x0000005
 Description Component ID2

Register COMPID2 Details

| Field Name | Bits | Type | Reset Value | Description |
|------------|------|------|-------------|-------------|
| Preamble | 7:0 | ro | 0x5 | Preamble |

Register ([dap](#)) COMPID3

Name COMPID3
 Relative Address 0x0000FFC
 Absolute Address 0xF880FFC
 Width 8 bits
 Access Type ro
 Reset Value 0x00000B1
 Description Component ID3

Register COMPID3 Details

| Field Name | Bits | Type | Reset Value | Description |
|------------|------|------|-------------|-------------|
| Preamble | 7:0 | ro | 0xB1 | Preamble |

B.11 CoreSight Embedded Trace Buffer (etb)

| | |
|--------------|---------------------------------------|
| Module Name | CoreSight Embedded Trace Buffer (etb) |
| Base Address | 0xF8801000 debug_etb |
| Description | Embedded Trace Buffer |
| Vendor Info | |

Register Summary

| Register Name | Address | Width | Type | Reset Value | Description |
|-----------------------------|------------|-------|-------|-------------|---|
| RDP | 0x00000004 | 32 | ro | 0x00000400 | RAM Depth Register |
| STS | 0x0000000C | 4 | ro | 0x00000000 | Status Register |
| RRD | 0x00000010 | 32 | ro | 0x00000000 | RAM Read Data Register |
| RRP | 0x00000014 | 10 | rw | 0x00000000 | RAM Read Pointer Register |
| RWP | 0x00000018 | 10 | rw | 0x00000000 | RAM Write Pointer Register |
| TRG | 0x0000001C | 10 | rw | 0x00000000 | Trigger Counter Register |
| CTL | 0x00000020 | 1 | rw | 0x00000000 | Control Register |
| RWD | 0x00000024 | 32 | rw | 0x00000000 | RAM Write Data Register |
| FFSR | 0x00000300 | 2 | ro | 0x00000002 | Formatter and Flush Status Register |
| FFCR | 0x00000304 | 14 | mixed | 0x00000200 | Formatter and Flush Control Register |
| ITMISCOPO | 0x00000EE0 | 2 | wo | 0x00000000 | Integration Test Miscellaneous Output Register 0 |
| ITTRFLINACK | 0x00000EE4 | 2 | wo | 0x00000000 | Integration Test Trigger In and Flush In Acknowledge Register |
| ITTRFLIN | 0x00000EE8 | 2 | wo | 0x00000000 | Integration Test Trigger In and Flush In Register |
| ITATBDATA0 | 0x00000EEC | 5 | ro | 0x00000000 | Integration Test ATB Data Register |
| ITATBCTR2 | 0x00000EF0 | 2 | wo | 0x00000000 | Integration Test ATB Control Register 2 |
| ITATBCTR1 | 0x00000EF4 | 7 | ro | 0x00000000 | Integration Test ATB Control Register 1 |
| ITATBCTR0 | 0x00000EF8 | 10 | ro | 0x00000000 | Integration Test ATB Control Register 0 |
| IMCR | 0x00000F00 | 1 | rw | 0x00000000 | Integration Mode Control Register |
| CTSR | 0x00000FA0 | 4 | rw | 0x0000000F | Claim Tag Set Register |
| CTCR | 0x00000FA4 | 4 | rw | 0x00000000 | Claim Tag Clear Register |

| Register Name | Address | Width | Type | Reset Value | Description |
|--------------------------|------------|-------|------|-------------|---------------------------------|
| LAR | 0x00000FB0 | 32 | wo | 0x00000000 | Lock Access Register |
| LSR | 0x00000FB4 | 3 | ro | 0x00000003 | Lock Status Register |
| ASR | 0x00000FB8 | 8 | ro | 0x00000000 | Authentication Status Register |
| DEVID | 0x00000FC8 | 6 | ro | 0x00000000 | Device ID |
| DTIR | 0x00000FCC | 8 | ro | 0x00000021 | Device Type Identifier Register |
| PERIPID4 | 0x00000FD0 | 8 | ro | 0x00000004 | Peripheral ID4 |
| PERIPID5 | 0x00000FD4 | 8 | ro | 0x00000000 | Peripheral ID5 |
| PERIPID6 | 0x00000FD8 | 8 | ro | 0x00000000 | Peripheral ID6 |
| PERIPID7 | 0x00000FDC | 8 | ro | 0x00000000 | Peripheral ID7 |
| PERIPID0 | 0x00000FE0 | 8 | ro | 0x00000007 | Peripheral ID0 |
| PERIPID1 | 0x00000FE4 | 8 | ro | 0x000000B9 | Peripheral ID1 |
| PERIPID2 | 0x00000FE8 | 8 | ro | 0x0000003B | Peripheral ID2 |
| PERIPID3 | 0x00000FEC | 8 | ro | 0x00000000 | Peripheral ID3 |
| COMPID0 | 0x00000FF0 | 8 | ro | 0x0000000D | Component ID0 |
| COMPID1 | 0x00000FF4 | 8 | ro | 0x00000090 | Component ID1 |
| COMPID2 | 0x00000FF8 | 8 | ro | 0x00000005 | Component ID2 |
| COMPID3 | 0x00000FFC | 8 | ro | 0x000000B1 | Component ID3 |

Register ([etb](#)) RDP

| | |
|------------------|--------------------|
| Name | RDP |
| Relative Address | 0x00000004 |
| Absolute Address | 0xF8801004 |
| Width | 32 bits |
| Access Type | ro |
| Reset Value | 0x00000400 |
| Description | RAM Depth Register |

Register RDP Details

| Field Name | Bits | Type | Reset Value | Description |
|------------|------|------|-------------|--|
| | 31:0 | ro | 0x400 | Defines the depth, in words, of the trace RAM. |

Register ([etb](#)) STS

| | |
|------------------|------------|
| Name | STS |
| Relative Address | 0x0000000C |

Absolute Address 0xF880100C
 Width 4 bits
 Access Type ro
 Reset Value 0x00000000
 Description Status Register

Register STS Details

| Field Name | Bits | Type | Reset Value | Description |
|------------|------|------|-------------|--|
| FtEmpty | 3 | ro | 0x0 | Formatter pipeline empty. All data stored to RAM. |
| AcqComp | 2 | ro | 0x0 | Acquisition complete. The acquisition complete flag indicates that capture has been completed when the formatter stops because of any of the methods defined in the Formatter and Flush Control Register, or TraceCaptEn = 0. This also results in FtStopped in the Formatter and Flush Status Register going HIGH. |
| Triggered | 1 | ro | 0x0 | The Triggered bit is set when a trigger has been observed. This does not indicate that a trigger has been embedded in the trace data by the formatter, but is determined by the programming of the Formatter and Flush Control Register. |
| Full | 0 | ro | 0x0 | RAM Full. The flag indicates when the RAM write pointer has wrapped around. |

Register (etb) RRD

Name RRD
 Relative Address 0x00000010
 Absolute Address 0xF8801010
 Width 32 bits
 Access Type ro
 Reset Value 0x00000000
 Description RAM Read Data Register

Register RRD Details

| Field Name | Bits | Type | Reset Value | Description |
|------------|------|------|-------------|-----------------------------------|
| | 31:0 | ro | 0x0 | Data read from the ETB Trace RAM. |

Register ([etb](#)) RRP

| | |
|------------------|---------------------------|
| Name | RRP |
| Relative Address | 0x00000014 |
| Absolute Address | 0xF8801014 |
| Width | 10 bits |
| Access Type | rw |
| Reset Value | 0x00000000 |
| Description | RAM Read Pointer Register |

Register RRP Details

| Field Name | Bits | Type | Reset Value | Description |
|------------|------|------|-------------|---|
| | 9:0 | rw | 0x0 | Sets the read pointer used to read entries from the Trace RAM over the APB interface. |

Register ([etb](#)) RWP

| | |
|------------------|----------------------------|
| Name | RWP |
| Relative Address | 0x00000018 |
| Absolute Address | 0xF8801018 |
| Width | 10 bits |
| Access Type | rw |
| Reset Value | 0x00000000 |
| Description | RAM Write Pointer Register |

Register RWP Details

| Field Name | Bits | Type | Reset Value | Description |
|------------|------|------|-------------|--|
| | 9:0 | rw | 0x0 | Sets the write pointer used to write entries from the CoreSight bus into the Trace RAM |

Register ([etb](#)) TRG

| | |
|------------------|------------|
| Name | TRG |
| Relative Address | 0x0000001C |
| Absolute Address | 0xF880101C |
| Width | 10 bits |
| Access Type | rw |
| Reset Value | 0x00000000 |

Description Trigger Counter Register

Register TRG Details

| Field Name | Bits | Type | Reset Value | Description |
|------------|------|------|-------------|--|
| | 9:0 | rw | 0x0 | <p>The counter is used as follows:</p> <ul style="list-style-type: none"> - Trace after The counter is set to a large value, slightly less than the number of entries in the RAM. - Trace before The counter is set to a small value. - Trace about The counter is set to half the depth of the Trace RAM. <p>This register must not be written to when trace capture is enabled (FtStopped=0, TraceCaptEn=1). If a write is attempted, the register is not updated. A read access is permitted with trace capture enabled.</p> |

Register (etb) CTL

Name CTL
 Relative Address 0x00000020
 Absolute Address 0xF8801020
 Width 1 bits
 Access Type rw
 Reset Value 0x00000000
 Description Control Register

Register CTL Details

| Field Name | Bits | Type | Reset Value | Description |
|-------------|------|------|-------------|---|
| TraceCaptEn | 0 | rw | 0x0 | <p>ETB Trace Capture Enable.</p> <ul style="list-style-type: none"> 1 = enable trace capture 0 = disable trace capture. <p>This is the master enable bit forcing FtStopped HIGH when TraceCaptEn is LOW.</p> <p>When capture is disabled, any remaining data in the ATB formatter is stored to RAM.</p> <p>When all data is stored the formatter outputs FtStopped. Capture is fully disabled, or complete, when FtStopped goes HIGH.</p> |

Register ([etb](#)) RWD

| | |
|------------------|-------------------------|
| Name | RWD |
| Relative Address | 0x00000024 |
| Absolute Address | 0xF8801024 |
| Width | 32 bits |
| Access Type | rw |
| Reset Value | 0x00000000 |
| Description | RAM Write Data Register |

Register RWD Details

| Field Name | Bits | Type | Reset Value | Description |
|------------|------|------|-------------|---|
| | 31:0 | rw | 0x0 | <p>Data written to the ETB Trace RAM.</p> <p>When trace capture is disabled, the contents of this register are placed into the ETB Trace RAM when this register is written to.</p> <p>Writing to this register increments the RAM Write Pointer Register.</p> <p>If trace capture is enabled, and this register is accessed, then a read from this register outputs 0xFFFFFFFF. Reads of this register never increment the RAM Write Pointer Register. A constant stream of 1s being output corresponds to a synchronization output from the ETB. If a write access is attempted, the data is not written into Trace RAM.</p> |

Register ([etb](#)) FFSR

| | |
|------------------|-------------------------------------|
| Name | FFSR |
| Relative Address | 0x00000300 |
| Absolute Address | 0xF8801300 |
| Width | 2 bits |
| Access Type | ro |
| Reset Value | 0x00000002 |
| Description | Formatter and Flush Status Register |

Register FFSR Details

| Field Name | Bits | Type | Reset Value | Description |
|------------|------|------|-------------|---|
| FtStopped | 1 | ro | 0x1 | Formatter stopped. The formatter has received a stop request signal and all trace data and post-amble has been output. Any more trace data on the ATB interface is ignored and ATREADY goes HIGH. |
| FlInProg | 0 | ro | 0x0 | Flush In Progress. This is an indication of the current state of AFVALIDS. |

Register ([etb](#)) FFCR

| | |
|------------------|--------------------------------------|
| Name | FFCR |
| Relative Address | 0x00000304 |
| Absolute Address | 0xF8801304 |
| Width | 14 bits |
| Access Type | mixed |
| Reset Value | 0x00000200 |
| Description | Formatter and Flush Control Register |

Register FFCR Details

| Field Name | Bits | Type | Reset Value | Description |
|------------|------|------|-------------|--|
| StopTrig | 13 | rw | 0x0 | Stop the formatter when a Trigger Event has been observed. |
| StopFl | 12 | rw | 0x0 | Stop the formatter when a flush has completed (return of AFREADY). This forces the FIFO to drain off any part-completed packets. Setting this bit enables this function but this is clear on reset (disabled). |
| reserved | 11 | ro | 0x0 | Reserved |
| TrigFl | 10 | rw | 0x0 | Indicate a trigger on Flush completion (AFREADY being returned). |
| TrigEvt | 9 | rw | 0x1 | Indicate a trigger on a Trigger Event. |
| TrigIn | 8 | rw | 0x0 | Indicate a trigger on TRIGIN being asserted. |
| reserved | 7 | ro | 0x0 | Reserved |
| FOnMan | 6 | rw | 0x0 | Manually generate a flush of the system. Setting this bit causes a flush to be generated. This is cleared when the flush has been serviced. This bit is clear on reset. |
| FOnTrig | 5 | rw | 0x0 | Generate flush using Trigger event. Set this bit to cause a flush of data in the system when a Trigger Event occurs. This bit is clear on reset. |

| Field Name | Bits | Type | Reset Value | Description |
|------------|------|------|-------------|--|
| FOnFlIn | 4 | rw | 0x0 | Generate flush using the FLUSHIN interface. Set this bit to enable use of the FLUSHIN connection. This bit is clear on reset. |
| reserved | 3:2 | ro | 0x0 | Reserved |
| EnFCont | 1 | rw | 0x0 | Continuous Formatting. Continuous mode in the ETB corresponds to normal mode with the embedding of triggers. Can only be changed when FtStopped is HIGH. This bit is clear on reset. |
| EnFTC | 0 | rw | 0x0 | Enable Formatting. Do not embed Triggers into the formatted stream. Trace disable cycles and triggers are indicated by TRACECTL, where fitted. Can only be changed when FtStopped is HIGH. This bit is clear on reset. |

Register ([etb](#)) ITMISCOPO

| | |
|------------------|--|
| Name | ITMISCOPO |
| Relative Address | 0x00000EE0 |
| Absolute Address | 0xF8801EE0 |
| Width | 2 bits |
| Access Type | wo |
| Reset Value | 0x00000000 |
| Description | Integration Test Miscellaneous Output Register 0 |

Register ITMISCOPO Details

| Field Name | Bits | Type | Reset Value | Description |
|------------|------|------|-------------|--------------------------|
| FULL | 1 | wo | 0x0 | Set the value of FULL |
| ACQCOMP | 0 | wo | 0x0 | Set the value of ACQCOMP |

Register ([etb](#)) ITTRFLINACK

| | |
|------------------|---|
| Name | ITTRFLINACK |
| Relative Address | 0x00000EE4 |
| Absolute Address | 0xF8801EE4 |
| Width | 2 bits |
| Access Type | wo |
| Reset Value | 0x00000000 |
| Description | Integration Test Trigger In and Flush In Acknowledge Register |

Register ITTRFLINACK Details

| Field Name | Bits | Type | Reset Value | Description |
|------------|------|------|-------------|-----------------------------|
| FLUSHINACK | 1 | wo | 0x0 | Set the value of FLUSHINACK |
| TRIGINACK | 0 | wo | 0x0 | Set the value of TRIGINACK |

Register ([etb](#)) ITTRFLIN

| | |
|------------------|---|
| Name | ITTRFLIN |
| Relative Address | 0x00000EE8 |
| Absolute Address | 0xF8801EE8 |
| Width | 2 bits |
| Access Type | wo |
| Reset Value | 0x00000000 |
| Description | Integration Test Trigger In and Flush In Register |

Register ITTRFLIN Details

| Field Name | Bits | Type | Reset Value | Description |
|------------|------|------|-------------|---------------------------|
| FLUSHIN | 1 | wo | 0x0 | Read the value of FLUSHIN |
| TRIGIN | 0 | wo | 0x0 | Read the value of TRIGIN |

Register ([etb](#)) ITATBDATA0

| | |
|------------------|------------------------------------|
| Name | ITATBDATA0 |
| Relative Address | 0x00000EEC |
| Absolute Address | 0xF8801EEC |
| Width | 5 bits |
| Access Type | ro |
| Reset Value | 0x00000000 |
| Description | Integration Test ATB Data Register |

Register ITATBDATA0 Details

| Field Name | Bits | Type | Reset Value | Description |
|------------|------|------|-------------|------------------------------|
| ATDATA31 | 4 | ro | 0x0 | Read the value of ATDATA[31] |
| ATDATA23 | 3 | ro | 0x0 | Read the value of ATDATA[23] |
| ATDATA15 | 2 | ro | 0x0 | Read the value of ATDATA[15] |

| Field Name | Bits | Type | Reset Value | Description |
|------------|------|------|-------------|-----------------------------|
| ATDATA7 | 1 | ro | 0x0 | Read the value of ATDATA[7] |
| ATDATA0 | 0 | ro | 0x0 | Read the value of ATDATA[0] |

Register ([etb](#)) ITATBCTR2

| | |
|------------------|---|
| Name | ITATBCTR2 |
| Relative Address | 0x00000EF0 |
| Absolute Address | 0xF8801EF0 |
| Width | 2 bits |
| Access Type | wo |
| Reset Value | 0x00000000 |
| Description | Integration Test ATB Control Register 2 |

Register ITATBCTR2 Details

| Field Name | Bits | Type | Reset Value | Description |
|------------|------|------|-------------|-----------------------------|
| AFVALIDS | 1 | wo | 0x0 | Set the value of AFVALIDS |
| ATREADYDYS | 0 | wo | 0x0 | Set the value of ATREADYDYS |

Register ([etb](#)) ITATBCTR1

| | |
|------------------|---|
| Name | ITATBCTR1 |
| Relative Address | 0x00000EF4 |
| Absolute Address | 0xF8801EF4 |
| Width | 7 bits |
| Access Type | ro |
| Reset Value | 0x00000000 |
| Description | Integration Test ATB Control Register 1 |

Register ITATBCTR1 Details

| Field Name | Bits | Type | Reset Value | Description |
|------------|------|------|-------------|-------------------------|
| ATID | 6:0 | ro | 0x0 | Read the value of ATIDS |

Register ([etb](#)) ITATBCTR0

| | |
|------------------|------------|
| Name | ITATBCTR0 |
| Relative Address | 0x00000EF8 |

Absolute Address 0xF8801EF8
 Width 10 bits
 Access Type ro
 Reset Value 0x00000000
 Description Integration Test ATB Control Register 0

Register ITATBCTRO Details

| Field Name | Bits | Type | Reset Value | Description |
|------------|------|------|-------------|---------------------------|
| ATBYTES | 9:8 | ro | 0x0 | Read the value of ATBYTES |
| reserved | 7:2 | ro | 0x0 | Reserved |
| AFREADY | 1 | ro | 0x0 | Read the value of AFREADY |
| ATVALID | 0 | ro | 0x0 | Read the value of ATVALID |

Register ([etb](#)) IMCR

Name IMCR
 Relative Address 0x00000F00
 Absolute Address 0xF8801F00
 Width 1 bits
 Access Type rw
 Reset Value 0x00000000
 Description Integration Mode Control Register

Register IMCR Details

| Field Name | Bits | Type | Reset Value | Description |
|------------|------|------|-------------|------------------------------------|
| | 0 | rw | 0x0 | Enable Integration Test registers. |

Register ([etb](#)) CTSR

Name CTSR
 Relative Address 0x00000FA0
 Absolute Address 0xF8801FA0
 Width 4 bits
 Access Type rw
 Reset Value 0x0000000F
 Description Claim Tag Set Register

Register CTSR Details

| Field Name | Bits | Type | Reset Value | Description |
|------------|------|------|-------------|---|
| | 3:0 | rw | 0xF | The claim tag register is used for any interrogating tools to determine if the device is being programmed or has been programmed. Read: 1= Claim tag is implemented, 0 = Claim tag is not implemented Write: 1= Set claim tag bit, 0= No effect |

Register ([etb](#)) CTCR

| | |
|------------------|--------------------------|
| Name | CTCR |
| Relative Address | 0x00000FA4 |
| Absolute Address | 0xF8801FA4 |
| Width | 4 bits |
| Access Type | rw |
| Reset Value | 0x00000000 |
| Description | Claim Tag Clear Register |

Register CTCR Details

| Field Name | Bits | Type | Reset Value | Description |
|------------|------|------|-------------|---|
| | 3:0 | rw | 0x0 | The claim tag register is used for any interrogating tools to determine if the device is being programmed or has been programmed. Read: Current value of claim tag. Write: 1= Clear claim tag bit, 0= No effect |

Register ([etb](#)) LAR

| | |
|------------------|----------------------|
| Name | LAR |
| Relative Address | 0x00000FB0 |
| Absolute Address | 0xF8801FB0 |
| Width | 32 bits |
| Access Type | wo |
| Reset Value | 0x00000000 |
| Description | Lock Access Register |

Register LAR Details

| Field Name | Bits | Type | Reset Value | Description |
|------------|------|------|-------------|---|
| | 31:0 | wo | 0x0 | <p>Write Access Code.</p> <p>Write behavior depends on PADDRDBG31 pin:</p> <ul style="list-style-type: none"> - PADDRDBG31=0 (lower 2GB): <p>After reset (via PRESETDBGn), ETB is locked, i.e., writes to all other registers using lower 2GB addresses are ignored.</p> <p>To unlock, 0xC5ACCE55 must be written this register.</p> <p>After the required registers are written, to lock again, write a value other than 0xC5ACCE55 to this register.</p> <ul style="list-style-type: none"> - PADDRDBG31=1 (upper 2GB): <p>ETB is unlocked when upper 2GB addresses are used to write to all the registers.</p> <p>However, write to this register is ignored using a upper 2GB address!</p> <p>Note: read from this register always returns 0, regardless of PADDRDBG31.</p> |

Register ([etb](#)) LSR

| | |
|------------------|----------------------|
| Name | LSR |
| Relative Address | 0x00000FB4 |
| Absolute Address | 0xF8801FB4 |
| Width | 3 bits |
| Access Type | ro |
| Reset Value | 0x00000003 |
| Description | Lock Status Register |

Register LSR Details

| Field Name | Bits | Type | Reset Value | Description |
|------------|------|------|-------------|---|
| 8BIT | 2 | ro | 0x0 | Set to 0 since ETB implements a 32-bit lock access register |

| Field Name | Bits | Type | Reset Value | Description |
|------------|------|------|-------------|--|
| STATUS | 1 | ro | 0x1 | Read behavior depends on PADDRDBG31 pin: - PADDRDBG31=0 (lower 2GB): When a lower 2GB address is used to read this register, this bit indicates whether ETB is in locked state (1= locked, 0= unlocked). - PADDRDBG31=1 (upper 2GB): always returns 0. |
| IMP | 0 | ro | 0x1 | Read behavior depends on PADDRDBG31 pin: - PADDRDBG31=0 (lower 2GB): always returns 1, meaning lock mechanism are implemented. - PADDRDBG31=1 (upper 2GB): always returns 0, meaning lock mechanism is NOT implemented. |

Register ([etb](#)) ASR

| | |
|------------------|--------------------------------|
| Name | ASR |
| Relative Address | 0x00000FB8 |
| Absolute Address | 0xF8801FB8 |
| Width | 8 bits |
| Access Type | ro |
| Reset Value | 0x00000000 |
| Description | Authentication Status Register |

Register ASR Details

| Field Name | Bits | Type | Reset Value | Description |
|------------|------|------|-------------|---|
| | 7:0 | ro | 0x0 | Indicates functionality not implemented |

Register ([etb](#)) DEVID

| | |
|------------------|------------|
| Name | DEVID |
| Relative Address | 0x00000FC8 |
| Absolute Address | 0xF8801FC8 |
| Width | 6 bits |
| Access Type | ro |
| Reset Value | 0x00000000 |
| Description | Device ID |

Register DEVID Details

| Field Name | Bits | Type | Reset Value | Description |
|------------|------|------|-------------|---------------------------------|
| SyncATCLK | 5 | ro | 0x0 | ETB RAM is synchronous to ATCLK |
| InputMux | 4:0 | ro | 0x0 | no input multiplexing |

Register ([etb](#)) DTIR

| | |
|------------------|---------------------------------|
| Name | DTIR |
| Relative Address | 0x00000FCC |
| Absolute Address | 0xF8801FCC |
| Width | 8 bits |
| Access Type | ro |
| Reset Value | 0x00000021 |
| Description | Device Type Identifier Register |

Register DTIR Details

| Field Name | Bits | Type | Reset Value | Description |
|------------|------|------|-------------|--------------------------------------|
| | 7:0 | ro | 0x21 | A trace sink and specifically an ETB |

Register ([etb](#)) PERIPHID4

| | |
|------------------|----------------|
| Name | PERIPHID4 |
| Relative Address | 0x00000FD0 |
| Absolute Address | 0xF8801FD0 |
| Width | 8 bits |
| Access Type | ro |
| Reset Value | 0x00000004 |
| Description | Peripheral ID4 |

Register PERIPHID4 Details

| Field Name | Bits | Type | Reset Value | Description |
|------------|------|------|-------------|--------------------------|
| 4KB_count | 7:4 | ro | 0x0 | 4KB Count, set to 0 |
| JEP106ID | 3:0 | ro | 0x4 | JEP106 continuation code |

Register ([etb](#)) PERIPHID5

| | |
|------------------|----------------|
| Name | PERIPHID5 |
| Relative Address | 0x00000FD4 |
| Absolute Address | 0xF8801FD4 |
| Width | 8 bits |
| Access Type | ro |
| Reset Value | 0x00000000 |
| Description | Peripheral ID5 |

Register PERIPHID5 Details

| Field Name | Bits | Type | Reset Value | Description |
|------------|------|------|-------------|-------------|
| | 7:0 | ro | 0x0 | reserved |

Register ([etb](#)) PERIPHID6

| | |
|------------------|----------------|
| Name | PERIPHID6 |
| Relative Address | 0x00000FD8 |
| Absolute Address | 0xF8801FD8 |
| Width | 8 bits |
| Access Type | ro |
| Reset Value | 0x00000000 |
| Description | Peripheral ID6 |

Register PERIPHID6 Details

| Field Name | Bits | Type | Reset Value | Description |
|------------|------|------|-------------|-------------|
| | 7:0 | ro | 0x0 | reserved |

Register ([etb](#)) PERIPHID7

| | |
|------------------|----------------|
| Name | PERIPHID7 |
| Relative Address | 0x00000FDC |
| Absolute Address | 0xF8801FDC |
| Width | 8 bits |
| Access Type | ro |
| Reset Value | 0x00000000 |
| Description | Peripheral ID7 |

Register PERIPHID7 Details

| Field Name | Bits | Type | Reset Value | Description |
|------------|------|------|-------------|-------------|
| | 7:0 | ro | 0x0 | reserved |

Register ([etb](#)) PERIPHID0

| | |
|------------------|----------------|
| Name | PERIPHID0 |
| Relative Address | 0x00000FE0 |
| Absolute Address | 0xF8801FE0 |
| Width | 8 bits |
| Access Type | ro |
| Reset Value | 0x00000007 |
| Description | Peripheral ID0 |

Register PERIPHID0 Details

| Field Name | Bits | Type | Reset Value | Description |
|------------|------|------|-------------|-------------|
| | 7:0 | ro | 0x7 | PartNumber0 |

Register ([etb](#)) PERIPHID1

| | |
|------------------|----------------|
| Name | PERIPHID1 |
| Relative Address | 0x00000FE4 |
| Absolute Address | 0xF8801FE4 |
| Width | 8 bits |
| Access Type | ro |
| Reset Value | 0x000000B9 |
| Description | Peripheral ID1 |

Register PERIPHID1 Details

| Field Name | Bits | Type | Reset Value | Description |
|-------------|------|------|-------------|----------------------------|
| JEP106ID | 7:4 | ro | 0xB | JEP106 Identity Code [3:0] |
| PartNumber1 | 3:0 | ro | 0x9 | PartNumber1 |

Register ([etb](#)) PERIPHID2

| | |
|------|-----------|
| Name | PERIPHID2 |
|------|-----------|

Relative Address 0x00000FE8
 Absolute Address 0xF8801FE8
 Width 8 bits
 Access Type ro
 Reset Value 0x0000003B
 Description Peripheral ID2

Register PERIPID2 Details

| Field Name | Bits | Type | Reset Value | Description |
|------------|------|------|-------------|---|
| RevNum | 7:4 | ro | 0x3 | Revision number of Peripheral |
| JEDEC | 3 | ro | 0x1 | Indicates that a JEDEC assigned value is used |
| JEP106ID | 2:0 | ro | 0x3 | JEP106 Identity Code [6:4] |

Register ([etb](#)) PERIPID3

Name PERIPID3
 Relative Address 0x00000FEC
 Absolute Address 0xF8801FEC
 Width 8 bits
 Access Type ro
 Reset Value 0x00000000
 Description Peripheral ID3

Register PERIPID3 Details

| Field Name | Bits | Type | Reset Value | Description |
|------------|------|------|-------------|----------------------|
| RevAnd | 7:4 | ro | 0x0 | RevAnd, at top level |
| CustMod | 3:0 | ro | 0x0 | Customer Modified |

Register ([etb](#)) COMPID0

Name COMPID0
 Relative Address 0x00000FF0
 Absolute Address 0xF8801FF0
 Width 8 bits
 Access Type ro
 Reset Value 0x0000000D
 Description Component ID0

Register COMPID0 Details

| Field Name | Bits | Type | Reset Value | Description |
|------------|------|------|-------------|-------------|
| | 7:0 | ro | 0xD | Preamble |

Register (etb) COMPID1

| | |
|------------------|---------------|
| Name | COMPID1 |
| Relative Address | 0x0000FF4 |
| Absolute Address | 0xF8801FF4 |
| Width | 8 bits |
| Access Type | ro |
| Reset Value | 0x00000090 |
| Description | Component ID1 |

Register COMPID1 Details

| Field Name | Bits | Type | Reset Value | Description |
|------------|------|------|-------------|-------------|
| | 7:0 | ro | 0x90 | Preamble |

Register (etb) COMPID2

| | |
|------------------|---------------|
| Name | COMPID2 |
| Relative Address | 0x0000FF8 |
| Absolute Address | 0xF8801FF8 |
| Width | 8 bits |
| Access Type | ro |
| Reset Value | 0x00000005 |
| Description | Component ID2 |

Register COMPID2 Details

| Field Name | Bits | Type | Reset Value | Description |
|------------|------|------|-------------|-------------|
| | 7:0 | ro | 0x5 | Preamble |

Register (etb) COMPID3

| | |
|------------------|-----------|
| Name | COMPID3 |
| Relative Address | 0x0000FFC |

Absolute Address 0xF8801FFC
 Width 8 bits
 Access Type ro
 Reset Value 0x000000B1
 Description Component ID3

Register COMPID3 Details

| Field Name | Bits | Type | Reset Value | Description |
|------------|------|------|-------------|-------------|
| | 7:0 | ro | 0xB1 | Preamble |

B.12 PL Fabric Trace Monitor (ftm)

| | |
|--------------|-------------------------------|
| Module Name | PL Fabric Trace Monitor (ftm) |
| Base Address | 0xF880B000 debug_ftm |
| Description | Fabric Trace Macrocell |
| Vendor Info | |

Register Summary

| Register Name | Address | Width | Type | Reset Value | Description |
|---------------------------------|------------|-------|------|-------------|--|
| FTMGLBCTRL | 0x00000000 | 1 | rw | 0x00000000 | FTM Global Control. |
| FTMSTATUS | 0x00000004 | 8 | ro | 0x00000082 | FTM Status Register |
| FTMCONTROL | 0x00000008 | 3 | rw | 0x00000000 | FTM Configuration |
| FTMP2FDBG0 | 0x0000000C | 8 | rw | 0x00000000 | FPGA Debug Register P2F0 |
| FTMP2FDBG1 | 0x00000010 | 8 | rw | 0x00000000 | FPGA Debug Register P2F1 |
| FTMP2FDBG2 | 0x00000014 | 8 | rw | 0x00000000 | FPGA Debug Register P2F2 |
| FTMP2FDBG3 | 0x00000018 | 8 | rw | 0x00000000 | FPGA Debug Register P2F3 |
| FTMF2PDBG0 | 0x0000001C | 8 | ro | 0x00000000 | FPGA Debug Register F2P0 |
| FTMF2PDBG1 | 0x00000020 | 8 | ro | 0x00000000 | FPGA Debug Register F2P1 |
| FTMF2PDBG2 | 0x00000024 | 8 | ro | 0x00000000 | FPGA Debug Register F2P2 |
| FTMF2PDBG3 | 0x00000028 | 8 | ro | 0x00000000 | FPGA Debug Register F2P3 |
| CYCOUNTPRE | 0x0000002C | 4 | rw | 0x00000000 | AXI Cycle Count clock pre-scaler |
| FTMSYNCRELOAD | 0x00000030 | 12 | rw | 0x00000000 | FTM Synchronization Counter reload value |
| FTMSYNCCOUT | 0x00000034 | 12 | ro | 0x00000000 | FTM Synchronization Counter value |
| FTMATID | 0x00000400 | 7 | rw | 0x00000000 | FTM ATID Value Register |
| FTMITTRIGOUTACK | 0x00000ED0 | 4 | ro | 0x00000000 | Trigger Output Acknowledge Integration Test Register |
| FTMITTRIGGER | 0x00000ED4 | 4 | wo | 0x00000000 | Trigger Output Integration Test Register |
| FTMITTRACEDIS | 0x00000ED8 | 1 | ro | 0x00000000 | External Trace Disable Integration Test Register |
| FTMITCYCCOUNT | 0x00000EDC | 32 | rw | 0x00000001 | Cycle Counter Test Register |
| FTMITATBDATA0 | 0x00000EEC | 5 | wo | 0x00000000 | ATB Data Integration Test Register 0 |
| FTMITATBCTR2 | 0x00000EF0 | 2 | ro | 0x00000001 | ATB Control Integration Test Register 2 |

| Register Name | Address | Width | Type | Reset Value | Description |
|-------------------------------|------------|-------|------|-------------|---|
| FTMITATBCTR1 | 0x00000EF4 | 7 | rw | 0x00000000 | ATB Control Integration Test Register 1 |
| FTMITATBCTR0 | 0x00000EF8 | 10 | wo | 0x00000000 | ATB Control Integration Test Register 0 |
| FTMITCR | 0x00000F00 | 1 | rw | 0x00000000 | FTM Test Control Register |
| CLAIMTAGSET | 0x00000FA0 | 8 | rw | 0x000000FF | Claim Tag Set Register |
| CLAIMTAGCLR | 0x00000FA4 | 8 | rw | 0x00000000 | Claim Tag Clear Register |
| LOCK_ACCESS | 0x00000FB0 | 32 | wo | 0x00000000 | Lock Access Register |
| LOCK_STATUS | 0x00000FB4 | 3 | ro | 0x00000003 | Lock Status Register |
| FTMAUTHSTATUS | 0x00000FB8 | 8 | ro | 0x00000088 | Authentication Status Register |
| FTMDEVID | 0x00000FC8 | 1 | ro | 0x00000000 | Device Configuration Register |
| FTMDEV_TYPE | 0x00000FCC | 8 | ro | 0x00000033 | Device Type Identification Register |
| FTMPERIPHID4 | 0x00000FD0 | 8 | ro | 0x00000000 | Peripheral ID4 |
| FTMPERIPHID5 | 0x00000FD4 | 8 | ro | 0x00000000 | Peripheral ID5 |
| FTMPERIPHID6 | 0x00000FD8 | 8 | ro | 0x00000000 | Peripheral ID6 |
| FTMPERIPHID7 | 0x00000FDC | 8 | ro | 0x00000000 | Peripheral ID7 |
| FTMPERIPHID0 | 0x00000FE0 | 8 | ro | 0x00000001 | Peripheral ID0 |
| FTMPERIPHID1 | 0x00000FE4 | 8 | ro | 0x00000090 | Peripheral ID1 |
| FTMPERIPHID2 | 0x00000FE8 | 8 | ro | 0x0000000C | Peripheral ID2 |
| FTMPERIPHID3 | 0x00000FEC | 8 | ro | 0x00000000 | Peripheral ID3 |
| FTMCOMPONID0 | 0x00000FF0 | 8 | ro | 0x0000000D | Component ID0 |
| FTMCOMPONID1 | 0x00000FF4 | 8 | ro | 0x00000090 | Component ID1 |
| FTMCOMPONID2 | 0x00000FF8 | 8 | ro | 0x00000005 | Component ID2 |
| FTMCOMPONID3 | 0x00000FFC | 8 | ro | 0x000000B1 | Component ID3 |

Register ([ftm](#)) FTMGLBCTRL

| | |
|------------------|---------------------|
| Name | FTMGLBCTRL |
| Relative Address | 0x00000000 |
| Absolute Address | 0xF880B000 |
| Width | 1 bits |
| Access Type | rw |
| Reset Value | 0x00000000 |
| Description | FTM Global Control. |

Register FTMGLBCTRL Details

| Field Name | Bits | Type | Reset Value | Description |
|------------|------|------|-------------|-------------|
| FTMENABLE | 0 | rw | 0x0 | Enable FTM |

Register ([ftm](#)) FTMSTATUS

| | |
|------------------|---------------------|
| Name | FTMSTATUS |
| Relative Address | 0x00000004 |
| Absolute Address | 0xF880B004 |
| Width | 8 bits |
| Access Type | ro |
| Reset Value | 0x00000082 |
| Description | FTM Status Register |

Register FTMSTATUS Details

| Field Name | Bits | Type | Reset Value | Description |
|------------|------|------|-------------|---------------------------------|
| IDLE | 7 | ro | 0x1 | FTM IDLE Status |
| SPIDEN | 6 | ro | 0x0 | Trustzone SPIDEN signal status |
| DBGEN | 5 | ro | 0x0 | Trustzone DBGEN signal status |
| SPNIDEN | 4 | ro | 0x0 | Trustzone SPNIDEN signal status |
| NIDEN | 3 | ro | 0x0 | Trustzone NIDEN signal status |
| FIFOFULL | 2 | ro | 0x0 | 1 = FIFO is full |
| FIFOEMPTY | 1 | ro | 0x1 | 1 = FIFO is empty |
| LOCKED | 0 | ro | 0x0 | Always read as zero |

Register ([ftm](#)) FTMCONTROL

| | |
|------------------|-------------------|
| Name | FTMCONTROL |
| Relative Address | 0x00000008 |
| Absolute Address | 0xF880B008 |
| Width | 3 bits |
| Access Type | rw |
| Reset Value | 0x00000000 |
| Description | FTM Configuration |

Register FTMCONTROL Details

| Field Name | Bits | Type | Reset Value | Description |
|------------|------|------|-------------|----------------------------|
| CYCEN | 2 | rw | 0x0 | Enable Cycle Count packets |
| TRACEN | 1 | rw | 0x0 | Enable Trace packets |
| PROG | 0 | rw | 0x0 | Not used |

Register ([ftm](#)) FTMP2FDBG0

| | |
|------------------|--------------------------|
| Name | FTMP2FDBG0 |
| Relative Address | 0x0000000C |
| Absolute Address | 0xF880B00C |
| Width | 8 bits |
| Access Type | rw |
| Reset Value | 0x00000000 |
| Description | FPGA Debug Register P2F0 |

Register FTMP2FDBG0 Details

| Field Name | Bits | Type | Reset Value | Description |
|------------|------|------|-------------|--|
| PSS2FPGA | 7:0 | rw | 0x0 | Signals presented to the fabric. These signals do not affect the FTM, they are provided for user specific debug. To modify the contents of this register, the SPIDEN pin must be asserted. |

Register ([ftm](#)) FTMP2FDBG1

| | |
|------------------|--------------------------|
| Name | FTMP2FDBG1 |
| Relative Address | 0x00000010 |
| Absolute Address | 0xF880B010 |
| Width | 8 bits |
| Access Type | rw |
| Reset Value | 0x00000000 |
| Description | FPGA Debug Register P2F1 |

Register FTMP2FDBG1 Details

| Field Name | Bits | Type | Reset Value | Description |
|------------|------|------|-------------|--|
| PSS2FPGA | 7:0 | rw | 0x0 | Signals presented to the fabric. These signals do not affect the FTM, they are provided for user specific debug. To modify the contents of this register, the SPIDEN pin must be asserted. |

Register ([ftm](#)) FTMP2FDBG2

| | |
|------------------|--------------------------|
| Name | FTMP2FDBG2 |
| Relative Address | 0x00000014 |
| Absolute Address | 0xF880B014 |
| Width | 8 bits |
| Access Type | rw |
| Reset Value | 0x00000000 |
| Description | FPGA Debug Register P2F2 |

Register FTMP2FDBG2 Details

| Field Name | Bits | Type | Reset Value | Description |
|------------|------|------|-------------|--|
| PSS2FPGA | 7:0 | rw | 0x0 | Signals presented to the fabric. These signals do not affect the FTM, they are provided for user specific debug. To modify the contents of this register, the SPIDEN pin must be asserted. |

Register ([ftm](#)) FTMP2FDBG3

| | |
|------------------|--------------------------|
| Name | FTMP2FDBG3 |
| Relative Address | 0x00000018 |
| Absolute Address | 0xF880B018 |
| Width | 8 bits |
| Access Type | rw |
| Reset Value | 0x00000000 |
| Description | FPGA Debug Register P2F3 |

Register FTMP2FDBG3 Details

| Field Name | Bits | Type | Reset Value | Description |
|------------|------|------|-------------|--|
| PSS2FPGA | 7:0 | rw | 0x0 | Signals presented to the fabric. These signals do not affect the FTM, they are provided for user specific debug. To modify the contents of this register, the SPIDEN pin must be asserted. |

Register ([ftm](#)) FTMF2PDBG0

| | |
|------------------|--------------------------|
| Name | FTMF2PDBG0 |
| Relative Address | 0x0000001C |
| Absolute Address | 0xF880B01C |
| Width | 8 bits |
| Access Type | ro |
| Reset Value | 0x00000000 |
| Description | FPGA Debug Register F2P0 |

Register FTMF2PDBG0 Details

| Field Name | Bits | Type | Reset Value | Description |
|------------|------|------|-------------|---|
| FPGA2PSS | 7:0 | ro | 0x0 | Signals that are presented to the PS from the Fabric. |

Register ([ftm](#)) FTMF2PDBG1

| | |
|------------------|--------------------------|
| Name | FTMF2PDBG1 |
| Relative Address | 0x00000020 |
| Absolute Address | 0xF880B020 |
| Width | 8 bits |
| Access Type | ro |
| Reset Value | 0x00000000 |
| Description | FPGA Debug Register F2P1 |

Register FTMF2PDBG1 Details

| Field Name | Bits | Type | Reset Value | Description |
|------------|------|------|-------------|---|
| FPGA2PSS | 7:0 | ro | 0x0 | Signals that are presented to the PS from the Fabric. |

Register ([ftm](#)) FTMF2PDBG2

| | |
|------------------|--------------------------|
| Name | FTMF2PDBG2 |
| Relative Address | 0x00000024 |
| Absolute Address | 0xF880B024 |
| Width | 8 bits |
| Access Type | ro |
| Reset Value | 0x00000000 |
| Description | FPGA Debug Register F2P2 |

Register FTMF2PDBG2 Details

| Field Name | Bits | Type | Reset Value | Description |
|------------|------|------|-------------|---|
| FPGA2PSS | 7:0 | ro | 0x0 | Signals that are presented to the PS from the Fabric. |

Register ([ftm](#)) FTMF2PDBG3

| | |
|------------------|--------------------------|
| Name | FTMF2PDBG3 |
| Relative Address | 0x00000028 |
| Absolute Address | 0xF880B028 |
| Width | 8 bits |
| Access Type | ro |
| Reset Value | 0x00000000 |
| Description | FPGA Debug Register F2P3 |

Register FTMF2PDBG3 Details

| Field Name | Bits | Type | Reset Value | Description |
|------------|------|------|-------------|---|
| FPGA2PSS | 7:0 | ro | 0x0 | Signals that are presented to the PS from the Fabric. |

Register ([ftm](#)) CYCOUNTPRE

| | |
|------------------|------------|
| Name | CYCOUNTPRE |
| Relative Address | 0x0000002C |
| Absolute Address | 0xF880B02C |
| Width | 4 bits |
| Access Type | rw |
| Reset Value | 0x00000000 |

Description AXI Cycle Count clock pre-scaler

Register CYCOUNTPRE Details

| Field Name | Bits | Type | Reset Value | Description |
|------------|------|------|-------------|--|
| PRESCALE | 3:0 | rw | 0x0 | The incoming clock is divided by 2 ^{PRESCALE} . For example: PRESCALE = 15 indicates that the Cycle Counter runs at the AXI clock divided by 2 ¹⁵ = 32,768 (PRESCALE = 0 indicates no clock scaling) |

Register ([ftm](#)) FTMSYNCRELOAD

Name FTMSYNCRELOAD
 Relative Address 0x00000030
 Absolute Address 0xF880B030
 Width 12 bits
 Access Type rw
 Reset Value 0x00000000
 Description FTM Synchronization Counter reload value

Register FTMSYNCRELOAD Details

| Field Name | Bits | Type | Reset Value | Description |
|---------------|------|------|-------------|---|
| SYNCCOUNTTERM | 11:0 | rw | 0x0 | Reset FTM Synchronization packet counter when this number of packets has been transmitted. The minimum value is 12. |

Register ([ftm](#)) FTMSYNCCOUT

Name FTMSYNCCOUT
 Relative Address 0x00000034
 Absolute Address 0xF880B034
 Width 12 bits
 Access Type ro
 Reset Value 0x00000000
 Description FTM Synchronization Counter value

Register FTMSYNCCOUT Details

| Field Name | Bits | Type | Reset Value | Description |
|------------|------|------|-------------|---|
| SYNCCOUT | 11:0 | ro | 0x0 | Current value of the Synchronization packet counter. The initial value is zero. The counter value increments every time a packet is issued by the FTM. When the counter reaches SYNCCOUNTTERM, a Synchronization packet is emitted. |

Register ([ftm](#)) FTMATID

| | |
|------------------|-------------------------|
| Name | FTMATID |
| Relative Address | 0x00000400 |
| Absolute Address | 0xF880B400 |
| Width | 7 bits |
| Access Type | rw |
| Reset Value | 0x00000000 |
| Description | FTM ATID Value Register |

Register FTMATID Details

| Field Name | Bits | Type | Reset Value | Description |
|------------|------|------|-------------|--|
| ATID | 6:0 | rw | 0x0 | ATID value supplied to ATB bus. The upper three bits, ATID[6:4], are directly driven from this register. The lower four bits, ATID[3:0], are OR-ed with the FTMDTRACEINATID[3:0] pins. |

Register ([ftm](#)) FTMITTRIGOUTACK

| | |
|------------------|--|
| Name | FTMITTRIGOUTACK |
| Relative Address | 0x00000ED0 |
| Absolute Address | 0xF880BED0 |
| Width | 4 bits |
| Access Type | ro |
| Reset Value | 0x00000000 |
| Description | Trigger Output Acknowledge Integration Test Register |

Register FTMITTRIGOUTACK Details

| Field Name | Bits | Type | Reset Value | Description |
|------------|------|------|-------------|---|
| TRIGACK | 3:0 | ro | 0x0 | Read the current value of the FTMTMP2FTRIGACK[3:0] inputs |

Register ([ftm](#)) FTMITTRIGGER

| | |
|------------------|--|
| Name | FTMITTRIGGER |
| Relative Address | 0x00000ED4 |
| Absolute Address | 0xF880BED4 |
| Width | 4 bits |
| Access Type | wo |
| Reset Value | 0x00000000 |
| Description | Trigger Output Integration Test Register |

Register FTMITTRIGGER Details

| Field Name | Bits | Type | Reset Value | Description |
|------------|------|------|-------------|---|
| TRIGGER | 3:0 | wo | 0x0 | When ITEN is 1, this field determines the FTMTMP2FTRIG[3:0] |

Register ([ftm](#)) FTMITTRACEDIS

| | |
|------------------|--|
| Name | FTMITTRACEDIS |
| Relative Address | 0x00000ED8 |
| Absolute Address | 0xF880BED8 |
| Width | 1 bits |
| Access Type | ro |
| Reset Value | 0x00000000 |
| Description | External Trace Disable Integration Test Register |

Register FTMITTRACEDIS Details

| Field Name | Bits | Type | Reset Value | Description |
|------------|------|------|-------------|----------------------|
| TRACEDIS | 0 | ro | 0x0 | Always read as zero. |

Register ([ftm](#)) FTMITCYCCOUNT

| | |
|------|---------------|
| Name | FTMITCYCCOUNT |
|------|---------------|

Relative Address 0x00000EDC
 Absolute Address 0xF880BEDC
 Width 32 bits
 Access Type rw
 Reset Value 0x00000001
 Description Cycle Counter Test Register

Register FTMITCYCCOUNT Details

| Field Name | Bits | Type | Reset Value | Description |
|-------------|------|------|-------------|---|
| FTMCYCCOUNT | 31:0 | rw | 0x1 | Read/write the value of the cycle counter |

Register ([ftm](#)) FTMITATBDATA0

Name FTMITATBDATA0
 Relative Address 0x00000EEC
 Absolute Address 0xF880BEEC
 Width 5 bits
 Access Type wo
 Reset Value 0x00000000
 Description ATB Data Integration Test Register 0

Register FTMITATBDATA0 Details

| Field Name | Bits | Type | Reset Value | Description |
|------------|------|------|-------------|--|
| ATDATA31 | 4 | wo | 0x0 | When ITEN is 1, this value determines the ATDATAM[31] output |
| ATDATA23 | 3 | wo | 0x0 | When ITEN is 1, this value determines the ATDATAM[23] output |
| ATDATA15 | 2 | wo | 0x0 | When ITEN is 1, this value determines the ATDATAM[15] output |
| ATDATA7 | 1 | wo | 0x0 | When ITEN is 1, this value determines the ATDATAM[7] output |
| ATDATA0 | 0 | wo | 0x0 | When ITEN is 1, this value determines the ATDATAM[0] output |

Register ([ftm](#)) FTMITATBCTR2

Name FTMITATBCTR2
 Relative Address 0x00000EF0

| | |
|------------------|---|
| Absolute Address | 0xF880BEF0 |
| Width | 2 bits |
| Access Type | ro |
| Reset Value | 0x00000001 |
| Description | ATB Control Integration Test Register 2 |

Register FTMITATBCTR2 Details

| Field Name | Bits | Type | Reset Value | Description |
|------------|------|------|-------------|--|
| AFVALID | 1 | ro | 0x0 | Read the current value of the AFVALIDM input |
| ATREADY | 0 | ro | 0x1 | Read the current value of the ATREADYM input |

Register ([ftm](#)) FTMITATBCTR1

| | |
|------------------|---|
| Name | FTMITATBCTR1 |
| Relative Address | 0x00000EF4 |
| Absolute Address | 0xF880BEF4 |
| Width | 7 bits |
| Access Type | rw |
| Reset Value | 0x00000000 |
| Description | ATB Control Integration Test Register 1 |

Register FTMITATBCTR1 Details

| Field Name | Bits | Type | Reset Value | Description |
|------------|------|------|-------------|---|
| ATID_test | 6:0 | rw | 0x0 | When ITEN is 1, this value determines the ATID output |

Register ([ftm](#)) FTMITATBCTR0

| | |
|------------------|---|
| Name | FTMITATBCTR0 |
| Relative Address | 0x00000EF8 |
| Absolute Address | 0xF880BEF8 |
| Width | 10 bits |
| Access Type | wo |
| Reset Value | 0x00000000 |
| Description | ATB Control Integration Test Register 0 |

Register FTMITATBCTRO Details

| Field Name | Bits | Type | Reset Value | Description |
|------------|------|------|-------------|--|
| ATBYTES | 9:8 | wo | 0x0 | When ITEN is 1, this value determines the ATBYTESM[1:0] output |
| reserved | 7:2 | wo | 0x0 | Reserved |
| AFREADY | 1 | wo | 0x0 | When ITEN is 1, this value determines the AFREADY output |
| ATVALID | 0 | wo | 0x0 | When ITEN is 1, this value determines the ATVALID output |

Register ([ftm](#)) FTMITCR

| | |
|------------------|---------------------------|
| Name | FTMITCR |
| Relative Address | 0x00000F00 |
| Absolute Address | 0xF880BF00 |
| Width | 1 bits |
| Access Type | rw |
| Reset Value | 0x00000000 |
| Description | FTM Test Control Register |

Register FTMITCR Details

| Field Name | Bits | Type | Reset Value | Description |
|------------|------|------|-------------|-------------------------|
| ITEN | 0 | rw | 0x0 | Integration Test Enable |

Register ([ftm](#)) CLAIMTAGSET

| | |
|------------------|------------------------|
| Name | CLAIMTAGSET |
| Relative Address | 0x00000FA0 |
| Absolute Address | 0xF880BFA0 |
| Width | 8 bits |
| Access Type | rw |
| Reset Value | 0x000000FF |
| Description | Claim Tag Set Register |

Register CLAIMTAGSET Details

| Field Name | Bits | Type | Reset Value | Description |
|----------------|------|------|-------------|---|
| CLAIMTAGSETVAL | 7:0 | rw | 0xFF | Read: 1 = Claim tag implemented, 0 = not implemented Write: 1 = Set claim tag bit, 0 = no effect |

Register ([ftm](#)) CLAIMTAGCLR

| | |
|------------------|--------------------------|
| Name | CLAIMTAGCLR |
| Relative Address | 0x00000FA4 |
| Absolute Address | 0xF880BFA4 |
| Width | 8 bits |
| Access Type | rw |
| Reset Value | 0x00000000 |
| Description | Claim Tag Clear Register |

Register CLAIMTAGCLR Details

| Field Name | Bits | Type | Reset Value | Description |
|----------------|------|------|-------------|--|
| CLAIMTAGCLRVAL | 7:0 | rw | 0x0 | Read: value of CLAIMTAGSETVAL Write: 1 = Clear claim tag bit, 0 = no effect |

Register ([ftm](#)) LOCK_ACCESS

| | |
|------------------|----------------------|
| Name | LOCK_ACCESS |
| Relative Address | 0x00000FB0 |
| Absolute Address | 0xF880BFB0 |
| Width | 32 bits |
| Access Type | wo |
| Reset Value | 0x00000000 |
| Description | Lock Access Register |

Register LOCK_ACCESS Details

| Field Name | Bits | Type | Reset Value | Description |
|------------|------|------|-------------|---|
| LOCKACCESS | 31:0 | wo | 0x0 | A value of 0xC5ACCE55 allows write access to FTM, any other value blocks write access |

Register ([ftm](#)) LOCK_STATUS

| | |
|------------------|----------------------|
| Name | LOCK_STATUS |
| Relative Address | 0x00000FB4 |
| Absolute Address | 0xF880BFB4 |
| Width | 3 bits |
| Access Type | ro |
| Reset Value | 0x00000003 |
| Description | Lock Status Register |

Register LOCK_STATUS Details

| Field Name | Bits | Type | Reset Value | Description |
|------------|------|------|-------------|--|
| 8BITACCESS | 2 | ro | 0x0 | 8-bit lock access is not used |
| LOCKSTATUS | 1 | ro | 0x1 | 1:Access Locked, 0:Access OK |
| LOCKIMP | 0 | ro | 0x1 | 1:Lock exists if PADDRDBG31 is low, else 0 |

Register ([ftm](#)) FTMAUTHSTATUS

| | |
|------------------|--------------------------------|
| Name | FTMAUTHSTATUS |
| Relative Address | 0x00000FB8 |
| Absolute Address | 0xF880BFB8 |
| Width | 8 bits |
| Access Type | ro |
| Reset Value | 0x00000088 |
| Description | Authentication Status Register |

Register FTMAUTHSTATUS Details

| Field Name | Bits | Type | Reset Value | Description |
|--------------|------|------|-------------|-------------------------------|
| AUTH_SPNIDEN | 7:6 | ro | 0x2 | Secure Non-Invasive Debug |
| reserved | 5:4 | ro | 0x0 | Secure Invasive Debug |
| AUTH_NIDEN | 3:2 | ro | 0x2 | Non-Secure Non-Invasive Debug |
| reserved | 1:0 | ro | 0x0 | Non-Secure Invasive Debug |

Register ([ftm](#)) FTMDEVID

| | |
|------------------|------------|
| Name | FTMDEVID |
| Relative Address | 0x00000FC8 |

Absolute Address 0xF880BFC8
 Width 1 bits
 Access Type ro
 Reset Value 0x00000000
 Description Device Configuration Register

Register FTMDEVID Details

| Field Name | Bits | Type | Reset Value | Description |
|------------|------|------|-------------|-------------|
| reserved | 0 | ro | 0x0 | Reserved |

Register ([ftm](#)) FTMDEV_TYPE

Name FTMDEV_TYPE
 Relative Address 0x00000FCC
 Absolute Address 0xF880BFCC
 Width 8 bits
 Access Type ro
 Reset Value 0x00000033
 Description Device Type Identification Register

Register FTMDEV_TYPE Details

| Field Name | Bits | Type | Reset Value | Description |
|------------|------|------|-------------|---|
| SubType | 7:4 | ro | 0x3 | Sub Type: Associated with a Data Engine or Co-processor |
| MajorType | 3:0 | ro | 0x3 | Major Type: Trace Source |

Register ([ftm](#)) FTMPERIPHID4

Name FTMPERIPHID4
 Relative Address 0x00000FD0
 Absolute Address 0xF880BFD0
 Width 8 bits
 Access Type ro
 Reset Value 0x00000000
 Description Peripheral ID4

Register FTMPERIPHID4 Details

| Field Name | Bits | Type | Reset Value | Description |
|------------|------|------|-------------|--------------------------|
| 4KBCount | 7:4 | ro | 0x0 | 4KB Count |
| JEP106 | 3:0 | ro | 0x0 | JEP106 Continuation Code |

Register ([ftm](#)) FTMPERIPHID5

| | |
|------------------|----------------|
| Name | FTMPERIPHID5 |
| Relative Address | 0x00000FD4 |
| Absolute Address | 0xF880BFD4 |
| Width | 8 bits |
| Access Type | ro |
| Reset Value | 0x00000000 |
| Description | Peripheral ID5 |

Register FTMPERIPHID5 Details

| Field Name | Bits | Type | Reset Value | Description |
|------------|------|------|-------------|-------------|
| reserved | 7:0 | ro | 0x0 | Reserved |

Register ([ftm](#)) FTMPERIPHID6

| | |
|------------------|----------------|
| Name | FTMPERIPHID6 |
| Relative Address | 0x00000FD8 |
| Absolute Address | 0xF880BFD8 |
| Width | 8 bits |
| Access Type | ro |
| Reset Value | 0x00000000 |
| Description | Peripheral ID6 |

Register FTMPERIPHID6 Details

| Field Name | Bits | Type | Reset Value | Description |
|------------|------|------|-------------|-------------|
| reserved | 7:0 | ro | 0x0 | Reserved |

Register ([ftm](#)) FTMPERIPHID7

| | |
|------|--------------|
| Name | FTMPERIPHID7 |
|------|--------------|

Relative Address 0x00000FDC
 Absolute Address 0xF880BFDC
 Width 8 bits
 Access Type ro
 Reset Value 0x00000000
 Description Peripheral ID7

Register FTMPERIPHID7 Details

| Field Name | Bits | Type | Reset Value | Description |
|------------|------|------|-------------|-------------|
| reserved | 7:0 | ro | 0x0 | Reserved |

Register ([ftm](#)) FTMPERIPHID0

Name FTMPERIPHID0
 Relative Address 0x00000FE0
 Absolute Address 0xF880BFE0
 Width 8 bits
 Access Type ro
 Reset Value 0x00000001
 Description Peripheral ID0

Register FTMPERIPHID0 Details

| Field Name | Bits | Type | Reset Value | Description |
|--------------|------|------|-------------|-------------------|
| PARTNUMLOWER | 7:0 | ro | 0x1 | Part Number Lower |

Register ([ftm](#)) FTMPERIPHID1

Name FTMPERIPHID1
 Relative Address 0x00000FE4
 Absolute Address 0xF880BFE4
 Width 8 bits
 Access Type ro
 Reset Value 0x00000090
 Description Peripheral ID1

Register FTMPERIPHID1 Details

| Field Name | Bits | Type | Reset Value | Description |
|--------------|------|------|-------------|----------------------------|
| JEP106 | 7:4 | ro | 0x9 | JEP106 identity bits [3:0] |
| PARTNUMUPPER | 3:0 | ro | 0x0 | Part Number Upper [11:8] |

Register ([ftm](#)) FTMPERIPHID2

| | |
|------------------|----------------|
| Name | FTMPERIPHID2 |
| Relative Address | 0x00000FE8 |
| Absolute Address | 0xF880BFE8 |
| Width | 8 bits |
| Access Type | ro |
| Reset Value | 0x0000000C |
| Description | Peripheral ID2 |

Register FTMPERIPHID2 Details

| Field Name | Bits | Type | Reset Value | Description |
|------------|------|------|-------------|-----------------------|
| REVISION | 7:4 | ro | 0x0 | Revision |
| JEDEC | 3 | ro | 0x1 | JEDEC used |
| JEP106 | 2:0 | ro | 0x4 | JEP106 Identity [6:4] |

Register ([ftm](#)) FTMPERIPHID3

| | |
|------------------|----------------|
| Name | FTMPERIPHID3 |
| Relative Address | 0x00000FEC |
| Absolute Address | 0xF880BFEC |
| Width | 8 bits |
| Access Type | ro |
| Reset Value | 0x00000000 |
| Description | Peripheral ID3 |

Register FTMPERIPHID3 Details

| Field Name | Bits | Type | Reset Value | Description |
|------------|------|------|-------------|-------------------|
| RevAnd | 7:4 | ro | 0x0 | RevAnd |
| CustMod | 3:0 | ro | 0x0 | Customer Modified |

Register ([ftm](#)) FTMCOMPONID0

Name FTMCOMPONID0
 Relative Address 0x00000FF0
 Absolute Address 0xF880BFF0
 Width 8 bits
 Access Type ro
 Reset Value 0x0000000D
 Description Component ID0

Register FTMCOMPONID0 Details

| Field Name | Bits | Type | Reset Value | Description |
|------------|------|------|-------------|-------------|
| Preamble | 7:0 | ro | 0xD | Preamble |

Register ([ftm](#)) FTMCOMPONID1

Name FTMCOMPONID1
 Relative Address 0x00000FF4
 Absolute Address 0xF880BFF4
 Width 8 bits
 Access Type ro
 Reset Value 0x00000090
 Description Component ID1

Register FTMCOMPONID1 Details

| Field Name | Bits | Type | Reset Value | Description |
|------------|------|------|-------------|--------------------------------------|
| CompClass | 7:4 | ro | 0x9 | Component Class :CoreSight Component |
| Preamble | 3:0 | ro | 0x0 | Preamble |

Register ([ftm](#)) FTMCOMPONID2

Name FTMCOMPONID2
 Relative Address 0x00000FF8
 Absolute Address 0xF880BFF8
 Width 8 bits
 Access Type ro
 Reset Value 0x00000005

Description Component ID2

Register FTMCOMPONID2 Details

| Field Name | Bits | Type | Reset Value | Description |
|------------|------|------|-------------|-------------|
| Preamble | 7:0 | ro | 0x5 | Preamble |

Register ([ftm](#)) FTMCOMPONID3

Name FTMCOMPONID3
 Relative Address 0x00000FFC
 Absolute Address 0xF880BFFC
 Width 8 bits
 Access Type ro
 Reset Value 0x000000B1
 Description Component ID3

Register FTMCOMPONID3 Details

| Field Name | Bits | Type | Reset Value | Description |
|------------|------|------|-------------|-------------|
| Preamble | 7:0 | ro | 0xB1 | Preamble |

B.13 CoreSight Trace Funnel (funnel)

Module Name CoreSight Trace Funnel (funnel)
 Base Address 0xF8804000 debug_funnel
 Description CoreSight Trace Funnel
 Vendor Info

Register Summary

| Register Name | Address | Width | Type | Reset Value | Description |
|----------------------------|------------|-------|-------|-------------|---|
| Control | 0x00000000 | 12 | rw | 0x00000300 | CSTF Control Register |
| PriControl | 0x00000004 | 24 | rw | 0x00FAC688 | CSTF Priority Control Register |
| ITATBDATA0 | 0x00000EEC | 5 | rw | 0x00000000 | Integration Test ATB Data 0 Register |
| ITATBCTR2 | 0x00000EF0 | 2 | rw | 0x00000000 | Integration Test ATB Control 2 Register |
| ITATBCTR1 | 0x00000EF4 | 7 | rw | 0x00000000 | Integration Test ATB Control 1 Register |
| ITATBCTR0 | 0x00000EF8 | 10 | mixed | 0x00000000 | Integration Test ATB Control 0 Register |
| IMCR | 0x00000F00 | 1 | rw | 0x00000000 | Integration Mode Control Register |
| CTSR | 0x00000FA0 | 4 | rw | 0x0000000F | Claim Tag Set Register |
| CTCR | 0x00000FA4 | 4 | rw | 0x00000000 | Claim Tag Clear Register |
| LAR | 0x00000FB0 | 32 | wo | 0x00000000 | Lock Access Register |
| LSR | 0x00000FB4 | 3 | ro | 0x00000003 | Lock Status Register |
| ASR | 0x00000FB8 | 8 | ro | 0x00000000 | Authentication Status Register |
| DEVID | 0x00000FC8 | 8 | ro | 0x00000028 | Device ID |
| DTIR | 0x00000FCC | 8 | ro | 0x00000012 | Device Type Identifier Register |
| PERIPHID4 | 0x00000FD0 | 8 | ro | 0x00000004 | Peripheral ID4 |
| PERIPHID5 | 0x00000FD4 | 8 | ro | 0x00000000 | Peripheral ID5 |
| PERIPHID6 | 0x00000FD8 | 8 | ro | 0x00000000 | Peripheral ID6 |
| PERIPHID7 | 0x00000FDC | 8 | ro | 0x00000000 | Peripheral ID7 |
| PERIPHID0 | 0x00000FE0 | 8 | ro | 0x00000008 | Peripheral ID0 |
| PERIPHID1 | 0x00000FE4 | 8 | ro | 0x000000B9 | Peripheral ID1 |
| PERIPHID2 | 0x00000FE8 | 8 | ro | 0x0000001B | Peripheral ID2 |
| PERIPHID3 | 0x00000FEC | 8 | ro | 0x00000000 | Peripheral ID3 |
| COMPID0 | 0x00000FF0 | 8 | ro | 0x0000000D | Component ID0 |

| Register Name | Address | Width | Type | Reset Value | Description |
|-------------------------|------------|-------|------|-------------|---------------|
| COMPID1 | 0x00000FF4 | 8 | ro | 0x00000090 | Component ID1 |
| COMPID2 | 0x00000FF8 | 8 | ro | 0x00000005 | Component ID2 |
| COMPID3 | 0x00000FFC | 8 | ro | 0x000000B1 | Component ID3 |

Register ([funnel](#)) Control

| | |
|------------------|-----------------------|
| Name | Control |
| Relative Address | 0x00000000 |
| Absolute Address | 0xF8804000 |
| Width | 12 bits |
| Access Type | rw |
| Reset Value | 0x00000300 |
| Description | CSTF Control Register |

Register Control Details

| Field Name | Bits | Type | Reset Value | Description |
|--------------|------|------|-------------|---|
| MinHoldTime | 11:8 | rw | 0x3 | The formatting scheme can easily become inefficient if fast switching occurs, so, where possible, this must be minimized. If a source has nothing to transmit, then another source is selected irrespective of the minimum number of cycles. Reset is 0x3. The CSTF holds for the minimum hold time and one additional cycle. The mFunnelum value that can be entered is 0xE and this equates to 15 cycles. 0xF is reserved. |
| EnableSlave7 | 7 | rw | 0x0 | Setting this bit enables this slave port. If the bit is not set then this has the effect of excluding the port from the priority selection scheme. |
| EnableSlave6 | 6 | rw | 0x0 | Setting this bit enables this slave port. If the bit is not set then this has the effect of excluding the port from the priority selection scheme. |
| EnableSlave5 | 5 | rw | 0x0 | Setting this bit enables this slave port. If the bit is not set then this has the effect of excluding the port from the priority selection scheme. |
| EnableSlave4 | 4 | rw | 0x0 | Setting this bit enables this slave port. If the bit is not set then this has the effect of excluding the port from the priority selection scheme. |
| EnableSlave3 | 3 | rw | 0x0 | Setting this bit enables this slave port. If the bit is not set then this has the effect of excluding the port from the priority selection scheme. |

| Field Name | Bits | Type | Reset Value | Description |
|--------------|------|------|-------------|--|
| EnableSlave2 | 2 | rw | 0x0 | Setting this bit enables this slave port. If the bit is not set then this has the effect of excluding the port from the priority selection scheme. |
| EnableSlave1 | 1 | rw | 0x0 | Setting this bit enables this slave port. If the bit is not set then this has the effect of excluding the port from the priority selection scheme. |
| EnableSlave0 | 0 | rw | 0x0 | Setting this bit enables this slave port. If the bit is not set then this has the effect of excluding the port from the priority selection scheme. |

Register ([funnel](#)) PriControl

| | |
|------------------|--------------------------------|
| Name | PriControl |
| Relative Address | 0x00000004 |
| Absolute Address | 0xF8804004 |
| Width | 24 bits |
| Access Type | rw |
| Reset Value | 0x00FAC688 |
| Description | CSTF Priority Control Register |

Register PriControl Details

| Field Name | Bits | Type | Reset Value | Description |
|------------|-------|------|-------------|--------------------------|
| PriPort7 | 23:21 | rw | 0x7 | 8th port priority value. |
| PriPort6 | 20:18 | rw | 0x6 | 7th port priority value. |
| PriPort5 | 17:15 | rw | 0x5 | 6th port priority value. |
| PriPort4 | 14:12 | rw | 0x4 | 5th port priority value. |
| PriPort3 | 11:9 | rw | 0x3 | 4th port priority value. |
| PriPort2 | 8:6 | rw | 0x2 | 3rd port priority value. |
| PriPort1 | 5:3 | rw | 0x1 | 2nd port priority value. |
| PriPort0 | 2:0 | rw | 0x0 | 1st port priority value. |

Register ([funnel](#)) ITATBDATA0

| | |
|------------------|------------|
| Name | ITATBDATA0 |
| Relative Address | 0x00000EEC |
| Absolute Address | 0xF8804EEC |
| Width | 5 bits |
| Access Type | rw |

Reset Value 0x00000000
 Description Integration Test ATB Data 0 Register

Register ITATBDATA0 Details

| Field Name | Bits | Type | Reset Value | Description |
|------------|------|------|-------------|---|
| ATDATA31 | 4 | rw | 0x0 | Read the value of ATDATAS[31], set the value of ATDATAM[31] |
| ATDATA23 | 3 | rw | 0x0 | Read the value of ATDATAS[23], set the value of ATDATAM[23] |
| ATDATA15 | 2 | rw | 0x0 | Read the value of ATDATAS[15], set the value of ATDATAM[15] |
| ATDATA7 | 1 | rw | 0x0 | Read the value of ATDATAS[7], set the value of ATDATAM[7] |
| ATDATA0 | 0 | rw | 0x0 | Read the value of ATDATAS[0], set the value of ATDATAM[0] |

Register (funnel) ITATBCTR2

Name ITATBCTR2
 Relative Address 0x00000EF0
 Absolute Address 0xF8804EF0
 Width 2 bits
 Access Type rw
 Reset Value 0x00000000
 Description Integration Test ATB Control 2 Register

Register ITATBCTR2 Details

| Field Name | Bits | Type | Reset Value | Description |
|------------|------|------|-------------|---|
| AFREADY | 1 | rw | 0x0 | Read the value of AFVALIDM. Set the value of AFVALIDS<n>, where <n> is defined by the status of the CSTF Control Register. |
| | 0 | rw | 0x0 | Read the value of ATREADYM. Set the value of ATREADYMS<n>, where <n> is defined by the status of the CSTF Control Register. |

Register (funnel) ITATBCTR1

Name ITATBCTR1
 Relative Address 0x00000EF4
 Absolute Address 0xF8804EF4

Width 7 bits
 Access Type rw
 Reset Value 0x00000000
 Description Integration Test ATB Control 1 Register

Register ITATBCTR1 Details

| Field Name | Bits | Type | Reset Value | Description |
|------------|------|------|-------------|--|
| ATID | 6:0 | rw | 0x0 | Read the value of ATIDS. Set the value of ATIDM. |

Register (funnel) ITATBCTR0

Name ITATBCTR0
 Relative Address 0x00000EF8
 Absolute Address 0xF8804EF8
 Width 10 bits
 Access Type mixed
 Reset Value 0x00000000
 Description Integration Test ATB Control 0 Register

Register ITATBCTR0 Details

| Field Name | Bits | Type | Reset Value | Description |
|------------|------|------|-------------|--|
| ATBYTES | 9:8 | rw | 0x0 | Read the value of ATBYTESS<n>. Set the value of ATBYTESM. |
| reserved | 7:2 | ro | 0x0 | Reserved |
| AFREADY | 1 | rw | 0x0 | Read the value of AFREADYSS<n>. Set the value of AFREADYM. |
| ATVALID | 0 | rw | 0x0 | Read the value of ATVALIDSS<n>. Set the value of ATVALIDM. |

Register (funnel) IMCR

Name IMCR
 Relative Address 0x00000F00
 Absolute Address 0xF8804F00
 Width 1 bits
 Access Type rw
 Reset Value 0x00000000
 Description Integration Mode Control Register

Register IMCR Details

| Field Name | Bits | Type | Reset Value | Description |
|------------|------|------|-------------|------------------------------------|
| | 0 | rw | 0x0 | Enable Integration Test registers. |

Register ([funnel](#)) CTSR

| | |
|------------------|------------------------|
| Name | CTSR |
| Relative Address | 0x00000FA0 |
| Absolute Address | 0xF8804FA0 |
| Width | 4 bits |
| Access Type | rw |
| Reset Value | 0x0000000F |
| Description | Claim Tag Set Register |

Register CTSR Details

| Field Name | Bits | Type | Reset Value | Description |
|------------|------|------|-------------|---|
| | 3:0 | rw | 0xF | The claim tag register is used for any interrogating tools to determine if the device is being programmed or has been programmed. Read: 1= Claim tag is implemented, 0 = Claim tag is not implemented Write: 1= Set claim tag bit, 0= No effect |

Register ([funnel](#)) CTCR

| | |
|------------------|--------------------------|
| Name | CTCR |
| Relative Address | 0x00000FA4 |
| Absolute Address | 0xF8804FA4 |
| Width | 4 bits |
| Access Type | rw |
| Reset Value | 0x00000000 |
| Description | Claim Tag Clear Register |

Register CTCR Details

| Field Name | Bits | Type | Reset Value | Description |
|------------|------|------|-------------|---|
| | 3:0 | rw | 0x0 | The claim tag register is used for any interrogating tools to determine if the device is being programmed or has been programmed. Read: Current value of claim tag. Write: 1= Clear claim tag bit, 0= No effect |

Register ([funnel](#)) LAR

| | |
|------------------|----------------------|
| Name | LAR |
| Relative Address | 0x00000FB0 |
| Absolute Address | 0xF8804FB0 |
| Width | 32 bits |
| Access Type | wo |
| Reset Value | 0x00000000 |
| Description | Lock Access Register |

Register LAR Details

| Field Name | Bits | Type | Reset Value | Description |
|------------|------|------|-------------|--|
| | 31:0 | wo | 0x0 | Write Access Code. Write behavior depends on PADDRDBG31 pin: - PADDRDBG31=0 (lower 2GB): After reset (via PRESETDBGn), Funnel is locked, i.e., writes to all other registers using lower 2GB addresses are ignored. To unlock, 0xC5ACCE55 must be written this register. After the required registers are written, to lock again, write a value other than 0xC5ACCE55 to this register. - PADDRDBG31=1 (upper 2GB): Funnel is unlocked when upper 2GB addresses are used to write to all the registers. However, write to this register is ignored using a upper 2GB address! Note: read from this register always returns 0, regardless of PADDRDBG31. |

Register ([funnel](#)) LSR

| | |
|------------------|------------|
| Name | LSR |
| Relative Address | 0x00000FB4 |

Absolute Address 0xF8804FB4
 Width 3 bits
 Access Type ro
 Reset Value 0x00000003
 Description Lock Status Register

Register LSR Details

| Field Name | Bits | Type | Reset Value | Description |
|------------|------|------|-------------|---|
| 8BIT | 2 | ro | 0x0 | Set to 0 since Funnel implements a 32-bit lock access register |
| STATUS | 1 | ro | 0x1 | Read behavior depends on PADDRDBG31 pin: - PADDRDBG31=0 (lower 2GB): When a lower 2GB address is used to read this register, this bit indicates whether Funnel is in locked state (1= locked, 0= unlocked). - PADDRDBG31=1 (upper 2GB): always returns 0. |
| IMP | 0 | ro | 0x1 | Read behavior depends on PADDRDBG31 pin: - PADDRDBG31=0 (lower 2GB): always returns 1, meaning lock mechanism are implemented. - PADDRDBG31=1 (upper 2GB): always returns 0, meaning lock mechanism is NOT implemented. |

Register (funnel) ASR

Name ASR
 Relative Address 0x00000FB8
 Absolute Address 0xF8804FB8
 Width 8 bits
 Access Type ro
 Reset Value 0x00000000
 Description Authentication Status Register

Register ASR Details

| Field Name | Bits | Type | Reset Value | Description |
|------------|------|------|-------------|---|
| | 7:0 | ro | 0x0 | Indicates functionality not implemented |

Register ([funnel](#)) DEVID

Name DEVID
 Relative Address 0x00000FC8
 Absolute Address 0xF8804FC8
 Width 8 bits
 Access Type ro
 Reset Value 0x00000028
 Description Device ID

Register DEVID Details

| Field Name | Bits | Type | Reset Value | Description |
|------------|------|------|-------------|--|
| StaticPrio | 7:4 | ro | 0x2 | CSTF implements a static priority scheme |
| NumInPorts | 3:0 | ro | 0x8 | Number of input ports |

Register ([funnel](#)) DTIR

Name DTIR
 Relative Address 0x00000FCC
 Absolute Address 0xF8804FCC
 Width 8 bits
 Access Type ro
 Reset Value 0x00000012
 Description Device Type Identifier Register

Register DTIR Details

| Field Name | Bits | Type | Reset Value | Description |
|------------|------|------|-------------|---|
| | 7:0 | ro | 0x12 | a trace link and specifically a funnel/router |

Register ([funnel](#)) PERIPHID4

Name PERIPHID4
 Relative Address 0x00000FD0
 Absolute Address 0xF8804FD0
 Width 8 bits
 Access Type ro
 Reset Value 0x00000004

Description Peripheral ID4

Register PERIPHID4 Details

| Field Name | Bits | Type | Reset Value | Description |
|------------|------|------|-------------|--------------------------|
| 4KB_count | 7:4 | ro | 0x0 | 4KB Count, set to 0 |
| JEP106ID | 3:0 | ro | 0x4 | JEP106 continuation code |

Register (funnel) PERIPHID5

Name PERIPHID5
 Relative Address 0x0000FD4
 Absolute Address 0xF8804FD4
 Width 8 bits
 Access Type ro
 Reset Value 0x00000000
 Description Peripheral ID5

Register PERIPHID5 Details

| Field Name | Bits | Type | Reset Value | Description |
|------------|------|------|-------------|-------------|
| | 7:0 | ro | 0x0 | reserved |

Register (funnel) PERIPHID6

Name PERIPHID6
 Relative Address 0x0000FD8
 Absolute Address 0xF8804FD8
 Width 8 bits
 Access Type ro
 Reset Value 0x00000000
 Description Peripheral ID6

Register PERIPHID6 Details

| Field Name | Bits | Type | Reset Value | Description |
|------------|------|------|-------------|-------------|
| | 7:0 | ro | 0x0 | reserved |

Register ([funnel](#)) PERIPHID7

Name PERIPHID7
 Relative Address 0x00000FDC
 Absolute Address 0xF8804FDC
 Width 8 bits
 Access Type ro
 Reset Value 0x00000000
 Description Peripheral ID7

Register PERIPHID7 Details

| Field Name | Bits | Type | Reset Value | Description |
|------------|------|------|-------------|-------------|
| | 7:0 | ro | 0x0 | reserved |

Register ([funnel](#)) PERIPHID0

Name PERIPHID0
 Relative Address 0x00000FE0
 Absolute Address 0xF8804FE0
 Width 8 bits
 Access Type ro
 Reset Value 0x00000008
 Description Peripheral ID0

Register PERIPHID0 Details

| Field Name | Bits | Type | Reset Value | Description |
|------------|------|------|-------------|-------------|
| | 7:0 | ro | 0x8 | PartNumber0 |

Register ([funnel](#)) PERIPHID1

Name PERIPHID1
 Relative Address 0x00000FE4
 Absolute Address 0xF8804FE4
 Width 8 bits
 Access Type ro
 Reset Value 0x000000B9
 Description Peripheral ID1

Register PERIPHID1 Details

| Field Name | Bits | Type | Reset Value | Description |
|-------------|------|------|-------------|----------------------------|
| JEP106ID | 7:4 | ro | 0xB | JEP106 Identity Code [3:0] |
| PartNumber1 | 3:0 | ro | 0x9 | PartNumber1 |

Register ([funnel](#)) PERIPHID2

| | |
|------------------|----------------|
| Name | PERIPHID2 |
| Relative Address | 0x00000FE8 |
| Absolute Address | 0xF8804FE8 |
| Width | 8 bits |
| Access Type | ro |
| Reset Value | 0x0000001B |
| Description | Peripheral ID2 |

Register PERIPHID2 Details

| Field Name | Bits | Type | Reset Value | Description |
|------------|------|------|-------------|---|
| RevNum | 7:4 | ro | 0x1 | Revision number of Peripheral |
| JEDEC | 3 | ro | 0x1 | Indicates that a JEDEC assigned value is used |
| JEP106ID | 2:0 | ro | 0x3 | JEP106 Identity Code [6:4] |

Register ([funnel](#)) PERIPHID3

| | |
|------------------|----------------|
| Name | PERIPHID3 |
| Relative Address | 0x00000FEC |
| Absolute Address | 0xF8804FEC |
| Width | 8 bits |
| Access Type | ro |
| Reset Value | 0x00000000 |
| Description | Peripheral ID3 |

Register PERIPHID3 Details

| Field Name | Bits | Type | Reset Value | Description |
|------------|------|------|-------------|----------------------|
| RevAnd | 7:4 | ro | 0x0 | RevAnd, at top level |
| CustMod | 3:0 | ro | 0x0 | Customer Modified |

Register ([funnel](#)) COMPID0

Name COMPID0
 Relative Address 0x00000FF0
 Absolute Address 0xF8804FF0
 Width 8 bits
 Access Type ro
 Reset Value 0x0000000D
 Description Component ID0

Register COMPID0 Details

| Field Name | Bits | Type | Reset Value | Description |
|------------|------|------|-------------|-------------|
| | 7:0 | ro | 0xD | Preamble |

Register ([funnel](#)) COMPID1

Name COMPID1
 Relative Address 0x00000FF4
 Absolute Address 0xF8804FF4
 Width 8 bits
 Access Type ro
 Reset Value 0x00000090
 Description Component ID1

Register COMPID1 Details

| Field Name | Bits | Type | Reset Value | Description |
|------------|------|------|-------------|-------------|
| | 7:0 | ro | 0x90 | Preamble |

Register ([funnel](#)) COMPID2

Name COMPID2
 Relative Address 0x00000FF8
 Absolute Address 0xF8804FF8
 Width 8 bits
 Access Type ro
 Reset Value 0x00000005
 Description Component ID2

Register COMPID2 Details

| Field Name | Bits | Type | Reset Value | Description |
|------------|------|------|-------------|-------------|
| | 7:0 | ro | 0x5 | Preamble |

Register ([funnel](#)) COMPID3

| | |
|------------------|---------------|
| Name | COMPID3 |
| Relative Address | 0x00000FFC |
| Absolute Address | 0xF8804FFC |
| Width | 8 bits |
| Access Type | ro |
| Reset Value | 0x000000B1 |
| Description | Component ID3 |

Register COMPID3 Details

| Field Name | Bits | Type | Reset Value | Description |
|------------|------|------|-------------|-------------|
| | 7:0 | ro | 0xB1 | Preamble |

B.14 CoreSight Intstrumentation Trace Macrocell (itm)

| | |
|--------------|--|
| Module Name | CoreSight Intstrumentation Trace Macrocell (itm) |
| Base Address | 0xF8805000 debug_itm |
| Description | Instrumentation Trace Macrocell |
| Vendor Info | |

Register Summary

| Register Name | Address | Width | Type | Reset Value | Description |
|----------------------------|------------|-------|------|-------------|---------------------------|
| StimPort00 | 0x00000000 | 32 | rw | 0x00000000 | Stimulus Port Register 0 |
| StimPort01 | 0x00000004 | 32 | rw | 0x00000000 | Stimulus Port Register 1 |
| StimPort02 | 0x00000008 | 32 | rw | 0x00000000 | Stimulus Port Register 2 |
| StimPort03 | 0x0000000C | 32 | rw | 0x00000000 | Stimulus Port Register 3 |
| StimPort04 | 0x00000010 | 32 | rw | 0x00000000 | Stimulus Port Register 4 |
| StimPort05 | 0x00000014 | 32 | rw | 0x00000000 | Stimulus Port Register 5 |
| StimPort06 | 0x00000018 | 32 | rw | 0x00000000 | Stimulus Port Register 6 |
| StimPort07 | 0x0000001C | 32 | rw | 0x00000000 | Stimulus Port Register 7 |
| StimPort08 | 0x00000020 | 32 | rw | 0x00000000 | Stimulus Port Register 8 |
| StimPort09 | 0x00000024 | 32 | rw | 0x00000000 | Stimulus Port Register 9 |
| StimPort10 | 0x00000028 | 32 | rw | 0x00000000 | Stimulus Port Register 10 |
| StimPort11 | 0x0000002C | 32 | rw | 0x00000000 | Stimulus Port Register 11 |
| StimPort12 | 0x00000030 | 32 | rw | 0x00000000 | Stimulus Port Register 12 |
| StimPort13 | 0x00000034 | 32 | rw | 0x00000000 | Stimulus Port Register 13 |
| StimPort14 | 0x00000038 | 32 | rw | 0x00000000 | Stimulus Port Register 14 |
| StimPort15 | 0x0000003C | 32 | rw | 0x00000000 | Stimulus Port Register 15 |
| StimPort16 | 0x00000040 | 32 | rw | 0x00000000 | Stimulus Port Register 16 |
| StimPort17 | 0x00000044 | 32 | rw | 0x00000000 | Stimulus Port Register 17 |
| StimPort18 | 0x00000048 | 32 | rw | 0x00000000 | Stimulus Port Register 18 |
| StimPort19 | 0x0000004C | 32 | rw | 0x00000000 | Stimulus Port Register 19 |
| StimPort20 | 0x00000050 | 32 | rw | 0x00000000 | Stimulus Port Register 20 |
| StimPort21 | 0x00000054 | 32 | rw | 0x00000000 | Stimulus Port Register 21 |
| StimPort22 | 0x00000058 | 32 | rw | 0x00000000 | Stimulus Port Register 22 |
| StimPort23 | 0x0000005C | 32 | rw | 0x00000000 | Stimulus Port Register 23 |
| StimPort24 | 0x00000060 | 32 | rw | 0x00000000 | Stimulus Port Register 24 |

| Register Name | Address | Width | Type | Reset Value | Description |
|------------------------------|------------|-------|-------|-------------|---|
| StimPort25 | 0x00000064 | 32 | rw | 0x00000000 | Stimulus Port Register 25 |
| StimPort26 | 0x00000068 | 32 | rw | 0x00000000 | Stimulus Port Register 26 |
| StimPort27 | 0x0000006C | 32 | rw | 0x00000000 | Stimulus Port Register 27 |
| StimPort28 | 0x00000070 | 32 | rw | 0x00000000 | Stimulus Port Register 28 |
| StimPort29 | 0x00000074 | 32 | rw | 0x00000000 | Stimulus Port Register 29 |
| StimPort30 | 0x00000078 | 32 | rw | 0x00000000 | Stimulus Port Register 30 |
| StimPort31 | 0x0000007C | 32 | rw | 0x00000000 | Stimulus Port Register 31 |
| TER | 0x00000E00 | 32 | rw | 0x00000000 | Trace Enable Register |
| TTR | 0x00000E20 | 32 | rw | 0x00000000 | Trace Trigger Register |
| CR | 0x00000E80 | 24 | mixed | 0x00000004 | Control Register |
| SCR | 0x00000E90 | 12 | rw | 0x00000400 | Synchronization Control Register |
| ITTRIGOUTACK | 0x00000EE4 | 1 | ro | 0x00000000 | Integration Test Trigger Out Acknowledge Register |
| ITTRIGOUT | 0x00000EE8 | 1 | wo | 0x00000000 | Integration Test Trigger Out Register |
| ITATBDATA0 | 0x00000EEC | 2 | wo | 0x00000000 | Integration Test ATB Data Register 0 |
| ITATBCTR2 | 0x00000EF0 | 1 | ro | 0x00000001 | Integration Test ATB Control Register 2 |
| ITATABCTR1 | 0x00000EF4 | 7 | wo | 0x00000000 | Integration Test ATB Control Register 1 |
| ITATBCTR0 | 0x00000EF8 | 2 | wo | 0x00000000 | Integration Test ATB Control Register 0 |
| IMCR | 0x00000F00 | 1 | rw | 0x00000000 | Integration Mode Control Register |
| CTSR | 0x00000FA0 | 8 | rw | 0x000000FF | Claim Tag Set Register |
| CTCR | 0x00000FA4 | 8 | rw | 0x00000000 | Claim Tag Clear Register |
| LAR | 0x00000FB0 | 32 | wo | 0x00000000 | Lock Access Register |
| LSR | 0x00000FB4 | 3 | ro | 0x00000003 | Lock Status Register |
| ASR | 0x00000FB8 | 8 | ro | 0x00000088 | Authentication Status Register |
| DEVID | 0x00000FC8 | 13 | ro | 0x00000020 | Device ID |
| DTIR | 0x00000FCC | 8 | ro | 0x00000043 | Device Type Identifier Register |
| PERIPID4 | 0x00000FD0 | 8 | ro | 0x00000004 | Peripheral ID4 |
| PERIPID5 | 0x00000FD4 | 8 | ro | 0x00000000 | Peripheral ID5 |
| PERIPID6 | 0x00000FD8 | 8 | ro | 0x00000000 | Peripheral ID6 |
| PERIPID7 | 0x00000FDC | 8 | ro | 0x00000000 | Peripheral ID7 |
| PERIPID0 | 0x00000FE0 | 8 | ro | 0x00000013 | Peripheral ID0 |
| PERIPID1 | 0x00000FE4 | 8 | ro | 0x000000B9 | Peripheral ID1 |

| Register Name | Address | Width | Type | Reset Value | Description |
|---------------------------|------------|-------|------|-------------|----------------|
| PERIPHID2 | 0x00000FE8 | 8 | ro | 0x0000002B | Peripheral ID2 |
| PERIPHID3 | 0x00000FEC | 8 | ro | 0x00000000 | Peripheral ID3 |
| COMPID0 | 0x00000FF0 | 8 | ro | 0x0000000D | Component ID0 |
| COMPID1 | 0x00000FF4 | 8 | ro | 0x00000090 | Component ID1 |
| COMPID2 | 0x00000FF8 | 8 | ro | 0x00000005 | Component ID2 |
| COMPID3 | 0x00000FFC | 8 | ro | 0x000000B1 | Component ID3 |

Register ([itm](#)) StimPort00

| | |
|------------------|--------------------------|
| Name | StimPort00 |
| Relative Address | 0x00000000 |
| Absolute Address | 0xF8805000 |
| Width | 32 bits |
| Access Type | rw |
| Reset Value | 0x00000000 |
| Description | Stimulus Port Register 0 |

Register StimPort00 Details

| Field Name | Bits | Type | Reset Value | Description |
|------------|------|------|-------------|---|
| | 31:0 | rw | 0x0 | <p>Each of the 32 stimulus ports is represented by a virtual address, creating 32 stimulus registers. A write to one of these locations causes data to be written into the FIFO if the corresponding bit in the Trace Enable Register is set and ITM is enabled. Reading from any of the stimulus ports returns the FIFO status (notFull(1) / Full(0)) only if the ITM is enabled. This enables more efficient core register allocation because the stimulus address has already been generated.</p> <p>The ITM transmits SWIT packets using leading zero compression. Packets can be 8, 16, or 32 bits. The bank of 32 registers is split into a low-16 (0 to 15) and a high-16 (16 to 31). Writes to the high-16 are discarded by the ITM whenever secure non-invasive trace is disabled, regardless of how the Trace Enable Register bits [31:16] are set. Both the high-16 and low-16 are disabled when non-invasive trace is disabled. When an input is disabled it must not alter the interface response and must always return an OK without stalling.</p> |

Register ([itm](#)) StimPort01

| | |
|------------------|--------------------------|
| Name | StimPort01 |
| Relative Address | 0x00000004 |
| Absolute Address | 0xF8805004 |
| Width | 32 bits |
| Access Type | rw |
| Reset Value | 0x00000000 |
| Description | Stimulus Port Register 1 |

Register StimPort01 Details

| Field Name | Bits | Type | Reset Value | Description |
|------------|------|------|-------------|---|
| | 31:0 | rw | 0x0 | <p>Each of the 32 stimulus ports is represented by a virtual address, creating 32 stimulus registers. A write to one of these locations causes data to be written into the FIFO if the corresponding bit in the Trace Enable Register is set and ITM is enabled. Reading from any of the stimulus ports returns the FIFO status (notFull(1) / Full(0)) only if the ITM is enabled. This enables more efficient core register allocation because the stimulus address has already been generated.</p> <p>The ITM transmits SWIT packets using leading zero compression. Packets can be 8, 16, or 32 bits. The bank of 32 registers is split into a low-16 (0 to 15) and a high-16 (16 to 31). Writes to the high-16 are discarded by the ITM whenever secure non-invasive trace is disabled, regardless of how the Trace Enable Register bits [31:16] are set. Both the high-16 and low-16 are disabled when non-invasive trace is disabled. When an input is disabled it must not alter the interface response and must always return an OK without stalling.</p> |

Register ([itm](#)) StimPort02

| | |
|------------------|--------------------------|
| Name | StimPort02 |
| Relative Address | 0x00000008 |
| Absolute Address | 0xF8805008 |
| Width | 32 bits |
| Access Type | rw |
| Reset Value | 0x00000000 |
| Description | Stimulus Port Register 2 |

Register StimPort02 Details

| Field Name | Bits | Type | Reset Value | Description |
|------------|------|------|-------------|---|
| | 31:0 | rw | 0x0 | <p>Each of the 32 stimulus ports is represented by a virtual address, creating 32 stimulus registers. A write to one of these locations causes data to be written into the FIFO if the corresponding bit in the Trace Enable Register is set and ITM is enabled. Reading from any of the stimulus ports returns the FIFO status (notFull(1) / Full(0)) only if the ITM is enabled. This enables more efficient core register allocation because the stimulus address has already been generated.</p> <p>The ITM transmits SWIT packets using leading zero compression. Packets can be 8, 16, or 32 bits. The bank of 32 registers is split into a low-16 (0 to 15) and a high-16 (16 to 31). Writes to the high-16 are discarded by the ITM whenever secure non-invasive trace is disabled, regardless of how the Trace Enable Register bits [31:16] are set. Both the high-16 and low-16 are disabled when non-invasive trace is disabled. When an input is disabled it must not alter the interface response and must always return an OK without stalling.</p> |

Register ([itm](#)) StimPort03

| | |
|------------------|--------------------------|
| Name | StimPort03 |
| Relative Address | 0x0000000C |
| Absolute Address | 0xF880500C |
| Width | 32 bits |
| Access Type | rw |
| Reset Value | 0x00000000 |
| Description | Stimulus Port Register 3 |

Register StimPort03 Details

| Field Name | Bits | Type | Reset Value | Description |
|------------|------|------|-------------|---|
| | 31:0 | rw | 0x0 | <p>Each of the 32 stimulus ports is represented by a virtual address, creating 32 stimulus registers. A write to one of these locations causes data to be written into the FIFO if the corresponding bit in the Trace Enable Register is set and ITM is enabled. Reading from any of the stimulus ports returns the FIFO status (notFull(1) / Full(0)) only if the ITM is enabled. This enables more efficient core register allocation because the stimulus address has already been generated.</p> <p>The ITM transmits SWIT packets using leading zero compression. Packets can be 8, 16, or 32 bits. The bank of 32 registers is split into a low-16 (0 to 15) and a high-16 (16 to 31). Writes to the high-16 are discarded by the ITM whenever secure non-invasive trace is disabled, regardless of how the Trace Enable Register bits [31:16] are set. Both the high-16 and low-16 are disabled when non-invasive trace is disabled. When an input is disabled it must not alter the interface response and must always return an OK without stalling.</p> |

Register ([itm](#)) StimPort04

| | |
|------------------|--------------------------|
| Name | StimPort04 |
| Relative Address | 0x00000010 |
| Absolute Address | 0xF8805010 |
| Width | 32 bits |
| Access Type | rw |
| Reset Value | 0x00000000 |
| Description | Stimulus Port Register 4 |

Register StimPort04 Details

| Field Name | Bits | Type | Reset Value | Description |
|------------|------|------|-------------|---|
| | 31:0 | rw | 0x0 | <p>Each of the 32 stimulus ports is represented by a virtual address, creating 32 stimulus registers. A write to one of these locations causes data to be written into the FIFO if the corresponding bit in the Trace Enable Register is set and ITM is enabled. Reading from any of the stimulus ports returns the FIFO status (notFull(1) / Full(0)) only if the ITM is enabled. This enables more efficient core register allocation because the stimulus address has already been generated.</p> <p>The ITM transmits SWIT packets using leading zero compression. Packets can be 8, 16, or 32 bits. The bank of 32 registers is split into a low-16 (0 to 15) and a high-16 (16 to 31). Writes to the high-16 are discarded by the ITM whenever secure non-invasive trace is disabled, regardless of how the Trace Enable Register bits [31:16] are set. Both the high-16 and low-16 are disabled when non-invasive trace is disabled. When an input is disabled it must not alter the interface response and must always return an OK without stalling.</p> |

Register ([itm](#)) StimPort05

| | |
|------------------|--------------------------|
| Name | StimPort05 |
| Relative Address | 0x00000014 |
| Absolute Address | 0xF8805014 |
| Width | 32 bits |
| Access Type | rw |
| Reset Value | 0x00000000 |
| Description | Stimulus Port Register 5 |

Register StimPort05 Details

| Field Name | Bits | Type | Reset Value | Description |
|------------|------|------|-------------|---|
| | 31:0 | rw | 0x0 | <p>Each of the 32 stimulus ports is represented by a virtual address, creating 32 stimulus registers. A write to one of these locations causes data to be written into the FIFO if the corresponding bit in the Trace Enable Register is set and ITM is enabled. Reading from any of the stimulus ports returns the FIFO status (notFull(1) / Full(0)) only if the ITM is enabled. This enables more efficient core register allocation because the stimulus address has already been generated.</p> <p>The ITM transmits SWIT packets using leading zero compression. Packets can be 8, 16, or 32 bits. The bank of 32 registers is split into a low-16 (0 to 15) and a high-16 (16 to 31). Writes to the high-16 are discarded by the ITM whenever secure non-invasive trace is disabled, regardless of how the Trace Enable Register bits [31:16] are set. Both the high-16 and low-16 are disabled when non-invasive trace is disabled. When an input is disabled it must not alter the interface response and must always return an OK without stalling.</p> |

Register ([itm](#)) StimPort06

| | |
|------------------|--------------------------|
| Name | StimPort06 |
| Relative Address | 0x00000018 |
| Absolute Address | 0xF8805018 |
| Width | 32 bits |
| Access Type | rw |
| Reset Value | 0x00000000 |
| Description | Stimulus Port Register 6 |

Register StimPort06 Details

| Field Name | Bits | Type | Reset Value | Description |
|------------|------|------|-------------|---|
| | 31:0 | rw | 0x0 | <p>Each of the 32 stimulus ports is represented by a virtual address, creating 32 stimulus registers. A write to one of these locations causes data to be written into the FIFO if the corresponding bit in the Trace Enable Register is set and ITM is enabled. Reading from any of the stimulus ports returns the FIFO status (notFull(1) / Full(0)) only if the ITM is enabled. This enables more efficient core register allocation because the stimulus address has already been generated.</p> <p>The ITM transmits SWIT packets using leading zero compression. Packets can be 8, 16, or 32 bits. The bank of 32 registers is split into a low-16 (0 to 15) and a high-16 (16 to 31). Writes to the high-16 are discarded by the ITM whenever secure non-invasive trace is disabled, regardless of how the Trace Enable Register bits [31:16] are set. Both the high-16 and low-16 are disabled when non-invasive trace is disabled. When an input is disabled it must not alter the interface response and must always return an OK without stalling.</p> |

Register ([itm](#)) StimPort07

| | |
|------------------|--------------------------|
| Name | StimPort07 |
| Relative Address | 0x0000001C |
| Absolute Address | 0xF880501C |
| Width | 32 bits |
| Access Type | rw |
| Reset Value | 0x00000000 |
| Description | Stimulus Port Register 7 |

Register StimPort07 Details

| Field Name | Bits | Type | Reset Value | Description |
|------------|------|------|-------------|---|
| | 31:0 | rw | 0x0 | <p>Each of the 32 stimulus ports is represented by a virtual address, creating 32 stimulus registers. A write to one of these locations causes data to be written into the FIFO if the corresponding bit in the Trace Enable Register is set and ITM is enabled. Reading from any of the stimulus ports returns the FIFO status (notFull(1) / Full(0)) only if the ITM is enabled. This enables more efficient core register allocation because the stimulus address has already been generated.</p> <p>The ITM transmits SWIT packets using leading zero compression. Packets can be 8, 16, or 32 bits. The bank of 32 registers is split into a low-16 (0 to 15) and a high-16 (16 to 31). Writes to the high-16 are discarded by the ITM whenever secure non-invasive trace is disabled, regardless of how the Trace Enable Register bits [31:16] are set. Both the high-16 and low-16 are disabled when non-invasive trace is disabled. When an input is disabled it must not alter the interface response and must always return an OK without stalling.</p> |

Register ([itm](#)) StimPort08

| | |
|------------------|--------------------------|
| Name | StimPort08 |
| Relative Address | 0x00000020 |
| Absolute Address | 0xF8805020 |
| Width | 32 bits |
| Access Type | rw |
| Reset Value | 0x00000000 |
| Description | Stimulus Port Register 8 |

Register StimPort08 Details

| Field Name | Bits | Type | Reset Value | Description |
|------------|------|------|-------------|---|
| | 31:0 | rw | 0x0 | <p>Each of the 32 stimulus ports is represented by a virtual address, creating 32 stimulus registers. A write to one of these locations causes data to be written into the FIFO if the corresponding bit in the Trace Enable Register is set and ITM is enabled. Reading from any of the stimulus ports returns the FIFO status (notFull(1) / Full(0)) only if the ITM is enabled. This enables more efficient core register allocation because the stimulus address has already been generated.</p> <p>The ITM transmits SWIT packets using leading zero compression. Packets can be 8, 16, or 32 bits. The bank of 32 registers is split into a low-16 (0 to 15) and a high-16 (16 to 31). Writes to the high-16 are discarded by the ITM whenever secure non-invasive trace is disabled, regardless of how the Trace Enable Register bits [31:16] are set. Both the high-16 and low-16 are disabled when non-invasive trace is disabled. When an input is disabled it must not alter the interface response and must always return an OK without stalling.</p> |

Register ([itm](#)) StimPort09

| | |
|------------------|--------------------------|
| Name | StimPort09 |
| Relative Address | 0x00000024 |
| Absolute Address | 0xF8805024 |
| Width | 32 bits |
| Access Type | rw |
| Reset Value | 0x00000000 |
| Description | Stimulus Port Register 9 |

Register StimPort09 Details

| Field Name | Bits | Type | Reset Value | Description |
|------------|------|------|-------------|---|
| | 31:0 | rw | 0x0 | <p>Each of the 32 stimulus ports is represented by a virtual address, creating 32 stimulus registers. A write to one of these locations causes data to be written into the FIFO if the corresponding bit in the Trace Enable Register is set and ITM is enabled. Reading from any of the stimulus ports returns the FIFO status (notFull(1) / Full(0)) only if the ITM is enabled. This enables more efficient core register allocation because the stimulus address has already been generated.</p> <p>The ITM transmits SWIT packets using leading zero compression. Packets can be 8, 16, or 32 bits. The bank of 32 registers is split into a low-16 (0 to 15) and a high-16 (16 to 31). Writes to the high-16 are discarded by the ITM whenever secure non-invasive trace is disabled, regardless of how the Trace Enable Register bits [31:16] are set. Both the high-16 and low-16 are disabled when non-invasive trace is disabled. When an input is disabled it must not alter the interface response and must always return an OK without stalling.</p> |

Register ([itm](#)) StimPort10

| | |
|------------------|---------------------------|
| Name | StimPort10 |
| Relative Address | 0x00000028 |
| Absolute Address | 0xF8805028 |
| Width | 32 bits |
| Access Type | rw |
| Reset Value | 0x00000000 |
| Description | Stimulus Port Register 10 |

Register StimPort10 Details

| Field Name | Bits | Type | Reset Value | Description |
|------------|------|------|-------------|---|
| | 31:0 | rw | 0x0 | <p>Each of the 32 stimulus ports is represented by a virtual address, creating 32 stimulus registers. A write to one of these locations causes data to be written into the FIFO if the corresponding bit in the Trace Enable Register is set and ITM is enabled. Reading from any of the stimulus ports returns the FIFO status (notFull(1) / Full(0)) only if the ITM is enabled. This enables more efficient core register allocation because the stimulus address has already been generated.</p> <p>The ITM transmits SWIT packets using leading zero compression. Packets can be 8, 16, or 32 bits. The bank of 32 registers is split into a low-16 (0 to 15) and a high-16 (16 to 31). Writes to the high-16 are discarded by the ITM whenever secure non-invasive trace is disabled, regardless of how the Trace Enable Register bits [31:16] are set. Both the high-16 and low-16 are disabled when non-invasive trace is disabled. When an input is disabled it must not alter the interface response and must always return an OK without stalling.</p> |

Register ([itm](#)) StimPort11

| | |
|------------------|---------------------------|
| Name | StimPort11 |
| Relative Address | 0x0000002C |
| Absolute Address | 0xF880502C |
| Width | 32 bits |
| Access Type | rw |
| Reset Value | 0x00000000 |
| Description | Stimulus Port Register 11 |

Register StimPort11 Details

| Field Name | Bits | Type | Reset Value | Description |
|------------|------|------|-------------|---|
| | 31:0 | rw | 0x0 | <p>Each of the 32 stimulus ports is represented by a virtual address, creating 32 stimulus registers. A write to one of these locations causes data to be written into the FIFO if the corresponding bit in the Trace Enable Register is set and ITM is enabled. Reading from any of the stimulus ports returns the FIFO status (notFull(1) / Full(0)) only if the ITM is enabled. This enables more efficient core register allocation because the stimulus address has already been generated.</p> <p>The ITM transmits SWIT packets using leading zero compression. Packets can be 8, 16, or 32 bits. The bank of 32 registers is split into a low-16 (0 to 15) and a high-16 (16 to 31). Writes to the high-16 are discarded by the ITM whenever secure non-invasive trace is disabled, regardless of how the Trace Enable Register bits [31:16] are set. Both the high-16 and low-16 are disabled when non-invasive trace is disabled. When an input is disabled it must not alter the interface response and must always return an OK without stalling.</p> |

Register ([itm](#)) StimPort12

| | |
|------------------|---------------------------|
| Name | StimPort12 |
| Relative Address | 0x00000030 |
| Absolute Address | 0xF8805030 |
| Width | 32 bits |
| Access Type | rw |
| Reset Value | 0x00000000 |
| Description | Stimulus Port Register 12 |

Register StimPort12 Details

| Field Name | Bits | Type | Reset Value | Description |
|------------|------|------|-------------|---|
| | 31:0 | rw | 0x0 | <p>Each of the 32 stimulus ports is represented by a virtual address, creating 32 stimulus registers. A write to one of these locations causes data to be written into the FIFO if the corresponding bit in the Trace Enable Register is set and ITM is enabled. Reading from any of the stimulus ports returns the FIFO status (notFull(1) / Full(0)) only if the ITM is enabled. This enables more efficient core register allocation because the stimulus address has already been generated.</p> <p>The ITM transmits SWIT packets using leading zero compression. Packets can be 8, 16, or 32 bits. The bank of 32 registers is split into a low-16 (0 to 15) and a high-16 (16 to 31). Writes to the high-16 are discarded by the ITM whenever secure non-invasive trace is disabled, regardless of how the Trace Enable Register bits [31:16] are set. Both the high-16 and low-16 are disabled when non-invasive trace is disabled. When an input is disabled it must not alter the interface response and must always return an OK without stalling.</p> |

Register ([itm](#)) StimPort13

| | |
|------------------|---------------------------|
| Name | StimPort13 |
| Relative Address | 0x00000034 |
| Absolute Address | 0xF8805034 |
| Width | 32 bits |
| Access Type | rw |
| Reset Value | 0x00000000 |
| Description | Stimulus Port Register 13 |

Register StimPort13 Details

| Field Name | Bits | Type | Reset Value | Description |
|------------|------|------|-------------|---|
| | 31:0 | rw | 0x0 | <p>Each of the 32 stimulus ports is represented by a virtual address, creating 32 stimulus registers. A write to one of these locations causes data to be written into the FIFO if the corresponding bit in the Trace Enable Register is set and ITM is enabled. Reading from any of the stimulus ports returns the FIFO status (notFull(1) / Full(0)) only if the ITM is enabled. This enables more efficient core register allocation because the stimulus address has already been generated.</p> <p>The ITM transmits SWIT packets using leading zero compression. Packets can be 8, 16, or 32 bits. The bank of 32 registers is split into a low-16 (0 to 15) and a high-16 (16 to 31). Writes to the high-16 are discarded by the ITM whenever secure non-invasive trace is disabled, regardless of how the Trace Enable Register bits [31:16] are set. Both the high-16 and low-16 are disabled when non-invasive trace is disabled. When an input is disabled it must not alter the interface response and must always return an OK without stalling.</p> |

Register ([itm](#)) StimPort14

| | |
|------------------|---------------------------|
| Name | StimPort14 |
| Relative Address | 0x00000038 |
| Absolute Address | 0xF8805038 |
| Width | 32 bits |
| Access Type | rw |
| Reset Value | 0x00000000 |
| Description | Stimulus Port Register 14 |

Register StimPort14 Details

| Field Name | Bits | Type | Reset Value | Description |
|------------|------|------|-------------|---|
| | 31:0 | rw | 0x0 | <p>Each of the 32 stimulus ports is represented by a virtual address, creating 32 stimulus registers. A write to one of these locations causes data to be written into the FIFO if the corresponding bit in the Trace Enable Register is set and ITM is enabled. Reading from any of the stimulus ports returns the FIFO status (notFull(1) / Full(0)) only if the ITM is enabled. This enables more efficient core register allocation because the stimulus address has already been generated.</p> <p>The ITM transmits SWIT packets using leading zero compression. Packets can be 8, 16, or 32 bits. The bank of 32 registers is split into a low-16 (0 to 15) and a high-16 (16 to 31). Writes to the high-16 are discarded by the ITM whenever secure non-invasive trace is disabled, regardless of how the Trace Enable Register bits [31:16] are set. Both the high-16 and low-16 are disabled when non-invasive trace is disabled. When an input is disabled it must not alter the interface response and must always return an OK without stalling.</p> |

Register ([itm](#)) StimPort15

| | |
|------------------|---------------------------|
| Name | StimPort15 |
| Relative Address | 0x0000003C |
| Absolute Address | 0xF880503C |
| Width | 32 bits |
| Access Type | rw |
| Reset Value | 0x00000000 |
| Description | Stimulus Port Register 15 |

Register StimPort15 Details

| Field Name | Bits | Type | Reset Value | Description |
|------------|------|------|-------------|---|
| | 31:0 | rw | 0x0 | <p>Each of the 32 stimulus ports is represented by a virtual address, creating 32 stimulus registers. A write to one of these locations causes data to be written into the FIFO if the corresponding bit in the Trace Enable Register is set and ITM is enabled. Reading from any of the stimulus ports returns the FIFO status (notFull(1) / Full(0)) only if the ITM is enabled. This enables more efficient core register allocation because the stimulus address has already been generated.</p> <p>The ITM transmits SWIT packets using leading zero compression. Packets can be 8, 16, or 32 bits. The bank of 32 registers is split into a low-16 (0 to 15) and a high-16 (16 to 31). Writes to the high-16 are discarded by the ITM whenever secure non-invasive trace is disabled, regardless of how the Trace Enable Register bits [31:16] are set. Both the high-16 and low-16 are disabled when non-invasive trace is disabled. When an input is disabled it must not alter the interface response and must always return an OK without stalling.</p> |

Register ([itm](#)) StimPort16

| | |
|------------------|---------------------------|
| Name | StimPort16 |
| Relative Address | 0x00000040 |
| Absolute Address | 0xF8805040 |
| Width | 32 bits |
| Access Type | rw |
| Reset Value | 0x00000000 |
| Description | Stimulus Port Register 16 |

Register StimPort16 Details

| Field Name | Bits | Type | Reset Value | Description |
|------------|------|------|-------------|---|
| | 31:0 | rw | 0x0 | <p>Each of the 32 stimulus ports is represented by a virtual address, creating 32 stimulus registers. A write to one of these locations causes data to be written into the FIFO if the corresponding bit in the Trace Enable Register is set and ITM is enabled. Reading from any of the stimulus ports returns the FIFO status (notFull(1) / Full(0)) only if the ITM is enabled. This enables more efficient core register allocation because the stimulus address has already been generated.</p> <p>The ITM transmits SWIT packets using leading zero compression. Packets can be 8, 16, or 32 bits. The bank of 32 registers is split into a low-16 (0 to 15) and a high-16 (16 to 31). Writes to the high-16 are discarded by the ITM whenever secure non-invasive trace is disabled, regardless of how the Trace Enable Register bits [31:16] are set. Both the high-16 and low-16 are disabled when non-invasive trace is disabled. When an input is disabled it must not alter the interface response and must always return an OK without stalling.</p> |

Register ([itm](#)) StimPort17

| | |
|------------------|---------------------------|
| Name | StimPort17 |
| Relative Address | 0x00000044 |
| Absolute Address | 0xF8805044 |
| Width | 32 bits |
| Access Type | rw |
| Reset Value | 0x00000000 |
| Description | Stimulus Port Register 17 |

Register StimPort17 Details

| Field Name | Bits | Type | Reset Value | Description |
|------------|------|------|-------------|---|
| | 31:0 | rw | 0x0 | <p>Each of the 32 stimulus ports is represented by a virtual address, creating 32 stimulus registers. A write to one of these locations causes data to be written into the FIFO if the corresponding bit in the Trace Enable Register is set and ITM is enabled. Reading from any of the stimulus ports returns the FIFO status (notFull(1) / Full(0)) only if the ITM is enabled. This enables more efficient core register allocation because the stimulus address has already been generated.</p> <p>The ITM transmits SWIT packets using leading zero compression. Packets can be 8, 16, or 32 bits. The bank of 32 registers is split into a low-16 (0 to 15) and a high-16 (16 to 31). Writes to the high-16 are discarded by the ITM whenever secure non-invasive trace is disabled, regardless of how the Trace Enable Register bits [31:16] are set. Both the high-16 and low-16 are disabled when non-invasive trace is disabled. When an input is disabled it must not alter the interface response and must always return an OK without stalling.</p> |

Register ([itm](#)) StimPort18

| | |
|------------------|---------------------------|
| Name | StimPort18 |
| Relative Address | 0x00000048 |
| Absolute Address | 0xF8805048 |
| Width | 32 bits |
| Access Type | rw |
| Reset Value | 0x00000000 |
| Description | Stimulus Port Register 18 |

Register StimPort18 Details

| Field Name | Bits | Type | Reset Value | Description |
|------------|------|------|-------------|---|
| | 31:0 | rw | 0x0 | <p>Each of the 32 stimulus ports is represented by a virtual address, creating 32 stimulus registers. A write to one of these locations causes data to be written into the FIFO if the corresponding bit in the Trace Enable Register is set and ITM is enabled. Reading from any of the stimulus ports returns the FIFO status (notFull(1) / Full(0)) only if the ITM is enabled. This enables more efficient core register allocation because the stimulus address has already been generated.</p> <p>The ITM transmits SWIT packets using leading zero compression. Packets can be 8, 16, or 32 bits. The bank of 32 registers is split into a low-16 (0 to 15) and a high-16 (16 to 31). Writes to the high-16 are discarded by the ITM whenever secure non-invasive trace is disabled, regardless of how the Trace Enable Register bits [31:16] are set. Both the high-16 and low-16 are disabled when non-invasive trace is disabled. When an input is disabled it must not alter the interface response and must always return an OK without stalling.</p> |

Register ([itm](#)) StimPort19

| | |
|------------------|---------------------------|
| Name | StimPort19 |
| Relative Address | 0x0000004C |
| Absolute Address | 0xF880504C |
| Width | 32 bits |
| Access Type | rw |
| Reset Value | 0x00000000 |
| Description | Stimulus Port Register 19 |

Register StimPort19 Details

| Field Name | Bits | Type | Reset Value | Description |
|------------|------|------|-------------|---|
| | 31:0 | rw | 0x0 | <p>Each of the 32 stimulus ports is represented by a virtual address, creating 32 stimulus registers. A write to one of these locations causes data to be written into the FIFO if the corresponding bit in the Trace Enable Register is set and ITM is enabled. Reading from any of the stimulus ports returns the FIFO status (notFull(1) / Full(0)) only if the ITM is enabled. This enables more efficient core register allocation because the stimulus address has already been generated.</p> <p>The ITM transmits SWIT packets using leading zero compression. Packets can be 8, 16, or 32 bits. The bank of 32 registers is split into a low-16 (0 to 15) and a high-16 (16 to 31). Writes to the high-16 are discarded by the ITM whenever secure non-invasive trace is disabled, regardless of how the Trace Enable Register bits [31:16] are set. Both the high-16 and low-16 are disabled when non-invasive trace is disabled. When an input is disabled it must not alter the interface response and must always return an OK without stalling.</p> |

Register ([itm](#)) StimPort20

| | |
|------------------|---------------------------|
| Name | StimPort20 |
| Relative Address | 0x00000050 |
| Absolute Address | 0xF8805050 |
| Width | 32 bits |
| Access Type | rw |
| Reset Value | 0x00000000 |
| Description | Stimulus Port Register 20 |

Register StimPort20 Details

| Field Name | Bits | Type | Reset Value | Description |
|------------|------|------|-------------|---|
| | 31:0 | rw | 0x0 | <p>Each of the 32 stimulus ports is represented by a virtual address, creating 32 stimulus registers. A write to one of these locations causes data to be written into the FIFO if the corresponding bit in the Trace Enable Register is set and ITM is enabled. Reading from any of the stimulus ports returns the FIFO status (notFull(1) / Full(0)) only if the ITM is enabled. This enables more efficient core register allocation because the stimulus address has already been generated.</p> <p>The ITM transmits SWIT packets using leading zero compression. Packets can be 8, 16, or 32 bits. The bank of 32 registers is split into a low-16 (0 to 15) and a high-16 (16 to 31). Writes to the high-16 are discarded by the ITM whenever secure non-invasive trace is disabled, regardless of how the Trace Enable Register bits [31:16] are set. Both the high-16 and low-16 are disabled when non-invasive trace is disabled. When an input is disabled it must not alter the interface response and must always return an OK without stalling.</p> |

Register ([itm](#)) StimPort21

| | |
|------------------|---------------------------|
| Name | StimPort21 |
| Relative Address | 0x00000054 |
| Absolute Address | 0xF8805054 |
| Width | 32 bits |
| Access Type | rw |
| Reset Value | 0x00000000 |
| Description | Stimulus Port Register 21 |

Register StimPort21 Details

| Field Name | Bits | Type | Reset Value | Description |
|------------|------|------|-------------|---|
| | 31:0 | rw | 0x0 | <p>Each of the 32 stimulus ports is represented by a virtual address, creating 32 stimulus registers. A write to one of these locations causes data to be written into the FIFO if the corresponding bit in the Trace Enable Register is set and ITM is enabled. Reading from any of the stimulus ports returns the FIFO status (notFull(1) / Full(0)) only if the ITM is enabled. This enables more efficient core register allocation because the stimulus address has already been generated.</p> <p>The ITM transmits SWIT packets using leading zero compression. Packets can be 8, 16, or 32 bits. The bank of 32 registers is split into a low-16 (0 to 15) and a high-16 (16 to 31). Writes to the high-16 are discarded by the ITM whenever secure non-invasive trace is disabled, regardless of how the Trace Enable Register bits [31:16] are set. Both the high-16 and low-16 are disabled when non-invasive trace is disabled. When an input is disabled it must not alter the interface response and must always return an OK without stalling.</p> |

Register ([itm](#)) StimPort22

| | |
|------------------|---------------------------|
| Name | StimPort22 |
| Relative Address | 0x00000058 |
| Absolute Address | 0xF8805058 |
| Width | 32 bits |
| Access Type | rw |
| Reset Value | 0x00000000 |
| Description | Stimulus Port Register 22 |

Register StimPort22 Details

| Field Name | Bits | Type | Reset Value | Description |
|------------|------|------|-------------|---|
| | 31:0 | rw | 0x0 | <p>Each of the 32 stimulus ports is represented by a virtual address, creating 32 stimulus registers. A write to one of these locations causes data to be written into the FIFO if the corresponding bit in the Trace Enable Register is set and ITM is enabled. Reading from any of the stimulus ports returns the FIFO status (notFull(1) / Full(0)) only if the ITM is enabled. This enables more efficient core register allocation because the stimulus address has already been generated.</p> <p>The ITM transmits SWIT packets using leading zero compression. Packets can be 8, 16, or 32 bits. The bank of 32 registers is split into a low-16 (0 to 15) and a high-16 (16 to 31). Writes to the high-16 are discarded by the ITM whenever secure non-invasive trace is disabled, regardless of how the Trace Enable Register bits [31:16] are set. Both the high-16 and low-16 are disabled when non-invasive trace is disabled. When an input is disabled it must not alter the interface response and must always return an OK without stalling.</p> |

Register ([itm](#)) StimPort23

| | |
|------------------|---------------------------|
| Name | StimPort23 |
| Relative Address | 0x0000005C |
| Absolute Address | 0xF880505C |
| Width | 32 bits |
| Access Type | rw |
| Reset Value | 0x00000000 |
| Description | Stimulus Port Register 23 |

Register StimPort23 Details

| Field Name | Bits | Type | Reset Value | Description |
|------------|------|------|-------------|---|
| | 31:0 | rw | 0x0 | <p>Each of the 32 stimulus ports is represented by a virtual address, creating 32 stimulus registers. A write to one of these locations causes data to be written into the FIFO if the corresponding bit in the Trace Enable Register is set and ITM is enabled. Reading from any of the stimulus ports returns the FIFO status (notFull(1) / Full(0)) only if the ITM is enabled. This enables more efficient core register allocation because the stimulus address has already been generated.</p> <p>The ITM transmits SWIT packets using leading zero compression. Packets can be 8, 16, or 32 bits. The bank of 32 registers is split into a low-16 (0 to 15) and a high-16 (16 to 31). Writes to the high-16 are discarded by the ITM whenever secure non-invasive trace is disabled, regardless of how the Trace Enable Register bits [31:16] are set. Both the high-16 and low-16 are disabled when non-invasive trace is disabled. When an input is disabled it must not alter the interface response and must always return an OK without stalling.</p> |

Register ([itm](#)) StimPort24

| | |
|------------------|---------------------------|
| Name | StimPort24 |
| Relative Address | 0x00000060 |
| Absolute Address | 0xF8805060 |
| Width | 32 bits |
| Access Type | rw |
| Reset Value | 0x00000000 |
| Description | Stimulus Port Register 24 |

Register StimPort24 Details

| Field Name | Bits | Type | Reset Value | Description |
|------------|------|------|-------------|---|
| | 31:0 | rw | 0x0 | <p>Each of the 32 stimulus ports is represented by a virtual address, creating 32 stimulus registers. A write to one of these locations causes data to be written into the FIFO if the corresponding bit in the Trace Enable Register is set and ITM is enabled. Reading from any of the stimulus ports returns the FIFO status (notFull(1) / Full(0)) only if the ITM is enabled. This enables more efficient core register allocation because the stimulus address has already been generated.</p> <p>The ITM transmits SWIT packets using leading zero compression. Packets can be 8, 16, or 32 bits. The bank of 32 registers is split into a low-16 (0 to 15) and a high-16 (16 to 31). Writes to the high-16 are discarded by the ITM whenever secure non-invasive trace is disabled, regardless of how the Trace Enable Register bits [31:16] are set. Both the high-16 and low-16 are disabled when non-invasive trace is disabled. When an input is disabled it must not alter the interface response and must always return an OK without stalling.</p> |

Register ([itm](#)) StimPort25

| | |
|------------------|---------------------------|
| Name | StimPort25 |
| Relative Address | 0x00000064 |
| Absolute Address | 0xF8805064 |
| Width | 32 bits |
| Access Type | rw |
| Reset Value | 0x00000000 |
| Description | Stimulus Port Register 25 |

Register StimPort25 Details

| Field Name | Bits | Type | Reset Value | Description |
|------------|------|------|-------------|---|
| | 31:0 | rw | 0x0 | <p>Each of the 32 stimulus ports is represented by a virtual address, creating 32 stimulus registers. A write to one of these locations causes data to be written into the FIFO if the corresponding bit in the Trace Enable Register is set and ITM is enabled. Reading from any of the stimulus ports returns the FIFO status (notFull(1) / Full(0)) only if the ITM is enabled. This enables more efficient core register allocation because the stimulus address has already been generated.</p> <p>The ITM transmits SWIT packets using leading zero compression. Packets can be 8, 16, or 32 bits. The bank of 32 registers is split into a low-16 (0 to 15) and a high-16 (16 to 31). Writes to the high-16 are discarded by the ITM whenever secure non-invasive trace is disabled, regardless of how the Trace Enable Register bits [31:16] are set. Both the high-16 and low-16 are disabled when non-invasive trace is disabled. When an input is disabled it must not alter the interface response and must always return an OK without stalling.</p> |

Register ([itm](#)) StimPort26

| | |
|------------------|---------------------------|
| Name | StimPort26 |
| Relative Address | 0x00000068 |
| Absolute Address | 0xF8805068 |
| Width | 32 bits |
| Access Type | rw |
| Reset Value | 0x00000000 |
| Description | Stimulus Port Register 26 |

Register StimPort26 Details

| Field Name | Bits | Type | Reset Value | Description |
|------------|------|------|-------------|---|
| | 31:0 | rw | 0x0 | <p>Each of the 32 stimulus ports is represented by a virtual address, creating 32 stimulus registers. A write to one of these locations causes data to be written into the FIFO if the corresponding bit in the Trace Enable Register is set and ITM is enabled. Reading from any of the stimulus ports returns the FIFO status (notFull(1) / Full(0)) only if the ITM is enabled. This enables more efficient core register allocation because the stimulus address has already been generated.</p> <p>The ITM transmits SWIT packets using leading zero compression. Packets can be 8, 16, or 32 bits. The bank of 32 registers is split into a low-16 (0 to 15) and a high-16 (16 to 31). Writes to the high-16 are discarded by the ITM whenever secure non-invasive trace is disabled, regardless of how the Trace Enable Register bits [31:16] are set. Both the high-16 and low-16 are disabled when non-invasive trace is disabled. When an input is disabled it must not alter the interface response and must always return an OK without stalling.</p> |

Register ([itm](#)) StimPort27

| | |
|------------------|---------------------------|
| Name | StimPort27 |
| Relative Address | 0x0000006C |
| Absolute Address | 0xF880506C |
| Width | 32 bits |
| Access Type | rw |
| Reset Value | 0x00000000 |
| Description | Stimulus Port Register 27 |

Register StimPort27 Details

| Field Name | Bits | Type | Reset Value | Description |
|------------|------|------|-------------|---|
| | 31:0 | rw | 0x0 | <p>Each of the 32 stimulus ports is represented by a virtual address, creating 32 stimulus registers. A write to one of these locations causes data to be written into the FIFO if the corresponding bit in the Trace Enable Register is set and ITM is enabled. Reading from any of the stimulus ports returns the FIFO status (notFull(1) / Full(0)) only if the ITM is enabled. This enables more efficient core register allocation because the stimulus address has already been generated.</p> <p>The ITM transmits SWIT packets using leading zero compression. Packets can be 8, 16, or 32 bits. The bank of 32 registers is split into a low-16 (0 to 15) and a high-16 (16 to 31). Writes to the high-16 are discarded by the ITM whenever secure non-invasive trace is disabled, regardless of how the Trace Enable Register bits [31:16] are set. Both the high-16 and low-16 are disabled when non-invasive trace is disabled. When an input is disabled it must not alter the interface response and must always return an OK without stalling.</p> |

Register ([itm](#)) StimPort28

| | |
|------------------|---------------------------|
| Name | StimPort28 |
| Relative Address | 0x00000070 |
| Absolute Address | 0xF8805070 |
| Width | 32 bits |
| Access Type | rw |
| Reset Value | 0x00000000 |
| Description | Stimulus Port Register 28 |

Register StimPort28 Details

| Field Name | Bits | Type | Reset Value | Description |
|------------|------|------|-------------|---|
| | 31:0 | rw | 0x0 | <p>Each of the 32 stimulus ports is represented by a virtual address, creating 32 stimulus registers. A write to one of these locations causes data to be written into the FIFO if the corresponding bit in the Trace Enable Register is set and ITM is enabled. Reading from any of the stimulus ports returns the FIFO status (notFull(1) / Full(0)) only if the ITM is enabled. This enables more efficient core register allocation because the stimulus address has already been generated.</p> <p>The ITM transmits SWIT packets using leading zero compression. Packets can be 8, 16, or 32 bits. The bank of 32 registers is split into a low-16 (0 to 15) and a high-16 (16 to 31). Writes to the high-16 are discarded by the ITM whenever secure non-invasive trace is disabled, regardless of how the Trace Enable Register bits [31:16] are set. Both the high-16 and low-16 are disabled when non-invasive trace is disabled. When an input is disabled it must not alter the interface response and must always return an OK without stalling.</p> |

Register ([itm](#)) StimPort29

| | |
|------------------|---------------------------|
| Name | StimPort29 |
| Relative Address | 0x00000074 |
| Absolute Address | 0xF8805074 |
| Width | 32 bits |
| Access Type | rw |
| Reset Value | 0x00000000 |
| Description | Stimulus Port Register 29 |

Register StimPort29 Details

| Field Name | Bits | Type | Reset Value | Description |
|------------|------|------|-------------|---|
| | 31:0 | rw | 0x0 | <p>Each of the 32 stimulus ports is represented by a virtual address, creating 32 stimulus registers. A write to one of these locations causes data to be written into the FIFO if the corresponding bit in the Trace Enable Register is set and ITM is enabled. Reading from any of the stimulus ports returns the FIFO status (notFull(1) / Full(0)) only if the ITM is enabled. This enables more efficient core register allocation because the stimulus address has already been generated.</p> <p>The ITM transmits SWIT packets using leading zero compression. Packets can be 8, 16, or 32 bits. The bank of 32 registers is split into a low-16 (0 to 15) and a high-16 (16 to 31). Writes to the high-16 are discarded by the ITM whenever secure non-invasive trace is disabled, regardless of how the Trace Enable Register bits [31:16] are set. Both the high-16 and low-16 are disabled when non-invasive trace is disabled. When an input is disabled it must not alter the interface response and must always return an OK without stalling.</p> |

Register ([itm](#)) StimPort30

| | |
|------------------|---------------------------|
| Name | StimPort30 |
| Relative Address | 0x00000078 |
| Absolute Address | 0xF8805078 |
| Width | 32 bits |
| Access Type | rw |
| Reset Value | 0x00000000 |
| Description | Stimulus Port Register 30 |

Register StimPort30 Details

| Field Name | Bits | Type | Reset Value | Description |
|------------|------|------|-------------|---|
| | 31:0 | rw | 0x0 | <p>Each of the 32 stimulus ports is represented by a virtual address, creating 32 stimulus registers. A write to one of these locations causes data to be written into the FIFO if the corresponding bit in the Trace Enable Register is set and ITM is enabled. Reading from any of the stimulus ports returns the FIFO status (notFull(1) / Full(0)) only if the ITM is enabled. This enables more efficient core register allocation because the stimulus address has already been generated.</p> <p>The ITM transmits SWIT packets using leading zero compression. Packets can be 8, 16, or 32 bits. The bank of 32 registers is split into a low-16 (0 to 15) and a high-16 (16 to 31). Writes to the high-16 are discarded by the ITM whenever secure non-invasive trace is disabled, regardless of how the Trace Enable Register bits [31:16] are set. Both the high-16 and low-16 are disabled when non-invasive trace is disabled. When an input is disabled it must not alter the interface response and must always return an OK without stalling.</p> |

Register ([itm](#)) StimPort31

| | |
|------------------|---------------------------|
| Name | StimPort31 |
| Relative Address | 0x0000007C |
| Absolute Address | 0xF880507C |
| Width | 32 bits |
| Access Type | rw |
| Reset Value | 0x00000000 |
| Description | Stimulus Port Register 31 |

Register StimPort31 Details

| Field Name | Bits | Type | Reset Value | Description |
|------------|------|------|-------------|---|
| | 31:0 | rw | 0x0 | <p>Each of the 32 stimulus ports is represented by a virtual address, creating 32 stimulus registers. A write to one of these locations causes data to be written into the FIFO if the corresponding bit in the Trace Enable Register is set and ITM is enabled. Reading from any of the stimulus ports returns the FIFO status (notFull(1) / Full(0)) only if the ITM is enabled. This enables more efficient core register allocation because the stimulus address has already been generated.</p> <p>The ITM transmits SWIT packets using leading zero compression. Packets can be 8, 16, or 32 bits. The bank of 32 registers is split into a low-16 (0 to 15) and a high-16 (16 to 31). Writes to the high-16 are discarded by the ITM whenever secure non-invasive trace is disabled, regardless of how the Trace Enable Register bits [31:16] are set. Both the high-16 and low-16 are disabled when non-invasive trace is disabled. When an input is disabled it must not alter the interface response and must always return an OK without stalling.</p> |

Register ([itm](#)) TER

| | |
|------------------|-----------------------|
| Name | TER |
| Relative Address | 0x00000E00 |
| Absolute Address | 0xF8805E00 |
| Width | 32 bits |
| Access Type | rw |
| Reset Value | 0x00000000 |
| Description | Trace Enable Register |

Register TER Details

| Field Name | Bits | Type | Reset Value | Description |
|------------|------|------|-------------|---|
| | 31:0 | rw | 0x0 | Bit mask to enable tracing on ITM stimulus ports. |

Register ([itm](#)) TTR

| | |
|------------------|------------|
| Name | TTR |
| Relative Address | 0x00000E20 |
| Absolute Address | 0xF8805E20 |

| | |
|-------------|------------------------|
| Width | 32 bits |
| Access Type | rw |
| Reset Value | 0x00000000 |
| Description | Trace Trigger Register |

Register TTR Details

| Field Name | Bits | Type | Reset Value | Description |
|------------|------|------|-------------|---|
| | 31:0 | rw | 0x0 | Bit mask to enable trigger generation, TRIGOUT, on selected writes to the Stimulus Registers. |

Register ([itm](#)) CR

| | |
|------------------|------------------|
| Name | CR |
| Relative Address | 0x00000E80 |
| Absolute Address | 0xF8805E80 |
| Width | 24 bits |
| Access Type | mixed |
| Reset Value | 0x00000004 |
| Description | Control Register |

Register CR Details

| Field Name | Bits | Type | Reset Value | Description |
|------------|-------|------|-------------|---|
| ITMBusy | 23 | rw | 0x0 | ITM is transmitting trace and FIFO is not empty |
| TraceID | 22:16 | rw | 0x0 | ATIDM[6:0] value |
| reserved | 15:10 | ro | 0x0 | Reserved |
| TSPrescale | 9:8 | rw | 0x0 | Timestamp Prescaler Enumerated Value List: DIVBY1=0. DIVBY4=1. DIVBY16=2. DIVBY64=3. |
| reserved | 7:4 | ro | 0x0 | Reserved |
| DWTEn | 3 | ro | 0x0 | Enable DWT input port |
| SYNCEn | 2 | ro | 0x1 | Enable sync packets |
| TSSEn | 1 | rw | 0x0 | Enable timestamps, delta |
| ITMEn | 0 | rw | 0x0 | Enable ITM Stimulus, also acts as a global enable |

Register ([itm](#)) SCR

| | |
|------------------|----------------------------------|
| Name | SCR |
| Relative Address | 0x00000E90 |
| Absolute Address | 0xF8805E90 |
| Width | 12 bits |
| Access Type | rw |
| Reset Value | 0x00000400 |
| Description | Synchronization Control Register |

Register SCR Details

| Field Name | Bits | Type | Reset Value | Description |
|------------|------|------|-------------|--|
| SyncCount | 11:0 | rw | 0x400 | Counter value for time between synchronization markers |

Register ([itm](#)) ITTRIGOUTACK

| | |
|------------------|---|
| Name | ITTRIGOUTACK |
| Relative Address | 0x00000EE4 |
| Absolute Address | 0xF8805EE4 |
| Width | 1 bits |
| Access Type | ro |
| Reset Value | 0x00000000 |
| Description | Integration Test Trigger Out Acknowledge Register |

Register ITTRIGOUTACK Details

| Field Name | Bits | Type | Reset Value | Description |
|--------------|------|------|-------------|------------------------------|
| ITTRIGOUTACK | 0 | ro | 0x0 | Read the value of TRIGOUTACK |

Register ([itm](#)) ITTRIGOUT

| | |
|------------------|------------|
| Name | ITTRIGOUT |
| Relative Address | 0x00000EE8 |
| Absolute Address | 0xF8805EE8 |
| Width | 1 bits |
| Access Type | wo |
| Reset Value | 0x00000000 |

Description Integration Test Trigger Out Register

Register ITTRIGOUT Details

| Field Name | Bits | Type | Reset Value | Description |
|------------|------|------|-------------|--------------------------|
| ITTRIGOUT | 0 | wo | 0x0 | Set the value of TRIGOUT |

Register ([itm](#)) ITATBDATA0

Name ITATBDATA0
 Relative Address 0x00000EEC
 Absolute Address 0xF8805EEC
 Width 2 bits
 Access Type wo
 Reset Value 0x00000000
 Description Integration Test ATB Data Register 0

Register ITATBDATA0 Details

| Field Name | Bits | Type | Reset Value | Description |
|------------|------|------|-------------|-----------------------------|
| ITATDATAM7 | 1 | wo | 0x0 | Set the value of ATDATAM[7] |
| ITATDATAM0 | 0 | wo | 0x0 | Set the value of ATDATAM[0] |

Register ([itm](#)) ITATBCTR2

Name ITATBCTR2
 Relative Address 0x00000EF0
 Absolute Address 0xF8805EF0
 Width 1 bits
 Access Type ro
 Reset Value 0x00000001
 Description Integration Test ATB Control Register 2

Register ITATBCTR2 Details

| Field Name | Bits | Type | Reset Value | Description |
|------------|------|------|-------------|----------------------------|
| ITATREADYM | 0 | ro | 0x1 | Read the value of ATREADYM |

Register ([itm](#)) ITATABCTR1

| | |
|------------------|---|
| Name | ITATABCTR1 |
| Relative Address | 0x00000EF4 |
| Absolute Address | 0xF8805EF4 |
| Width | 7 bits |
| Access Type | wo |
| Reset Value | 0x00000000 |
| Description | Integration Test ATB Control Register 1 |

Register ITATABCTR1 Details

| Field Name | Bits | Type | Reset Value | Description |
|------------|------|------|-------------|-----------------------------|
| ITATIDM | 6:0 | wo | 0x0 | Set the value of ATIDM[6:0] |

Register ([itm](#)) ITATBCTR0

| | |
|------------------|---|
| Name | ITATBCTR0 |
| Relative Address | 0x00000EF8 |
| Absolute Address | 0xF8805EF8 |
| Width | 2 bits |
| Access Type | wo |
| Reset Value | 0x00000000 |
| Description | Integration Test ATB Control Register 0 |

Register ITATBCTR0 Details

| Field Name | Bits | Type | Reset Value | Description |
|------------|------|------|-------------|---------------------------|
| ITAFREADYM | 1 | wo | 0x0 | Set the value of AFREADYM |
| ITATVALIDM | 0 | wo | 0x0 | Set the value of ATVALIDM |

Register ([itm](#)) IMCR

| | |
|------------------|------------|
| Name | IMCR |
| Relative Address | 0x00000F00 |
| Absolute Address | 0xF8805F00 |
| Width | 1 bits |
| Access Type | rw |
| Reset Value | 0x00000000 |

Description Integration Mode Control Register

Register IMCR Details

| Field Name | Bits | Type | Reset Value | Description |
|------------|------|------|-------------|------------------------------------|
| | 0 | rw | 0x0 | Enable Integration Test registers. |

Register ([itm](#)) CTSR

Name CTSR
 Relative Address 0x00000FA0
 Absolute Address 0xF8805FA0
 Width 8 bits
 Access Type rw
 Reset Value 0x000000FF
 Description Claim Tag Set Register

Register CTSR Details

| Field Name | Bits | Type | Reset Value | Description |
|------------|------|------|-------------|---|
| | 7:0 | rw | 0xFF | The claim tag register is used for any interrogating tools to determine if the device is being programmed or has been programmed. Read: 1= Claim tag is implemented, 0 = Claim tag is not implemented Write: 1= Set claim tag bit, 0= No effect |

Register ([itm](#)) CTCR

Name CTCR
 Relative Address 0x00000FA4
 Absolute Address 0xF8805FA4
 Width 8 bits
 Access Type rw
 Reset Value 0x00000000
 Description Claim Tag Clear Register

Register CTCR Details

| Field Name | Bits | Type | Reset Value | Description |
|------------|------|------|-------------|---|
| | 7:0 | rw | 0x0 | The claim tag register is used for any interrogating tools to determine if the device is being programmed or has been programmed. Read: Current value of claim tag. Write: 1= Clear claim tag bit, 0= No effect |

Register ([itm](#)) LAR

| | |
|------------------|----------------------|
| Name | LAR |
| Relative Address | 0x00000FB0 |
| Absolute Address | 0xF8805FB0 |
| Width | 32 bits |
| Access Type | wo |
| Reset Value | 0x00000000 |
| Description | Lock Access Register |

Register LAR Details

| Field Name | Bits | Type | Reset Value | Description |
|------------|------|------|-------------|--|
| | 31:0 | wo | 0x0 | Write Access Code. Write behavior depends on PADDRDBG31 pin: - PADDRDBG31=0 (lower 2GB): After reset (via PRESETDBGn), ITM is locked, i.e., writes to all other registers using lower 2GB addresses are ignored. To unlock, 0xC5ACCE55 must be written this register. After the required registers are written, to lock again, write a value other than 0xC5ACCE55 to this register. - PADDRDBG31=1 (upper 2GB): ITM is unlocked when upper 2GB addresses are used to write to all the registers. However, write to this register is ignored using a upper 2GB address! Note: read from this register always returns 0, regardless of PADDRDBG31. |

Register ([itm](#)) LSR

| | |
|------------------|------------|
| Name | LSR |
| Relative Address | 0x00000FB4 |

Absolute Address 0xF8805FB4
 Width 3 bits
 Access Type ro
 Reset Value 0x00000003
 Description Lock Status Register

Register LSR Details

| Field Name | Bits | Type | Reset Value | Description |
|------------|------|------|-------------|--|
| 8BIT | 2 | ro | 0x0 | Set to 0 since ITM implements a 32-bit lock access register |
| STATUS | 1 | ro | 0x1 | Read behavior depends on PADDRDBG31 pin: - PADDRDBG31=0 (lower 2GB): When a lower 2GB address is used to read this register, this bit indicates whether ITM is in locked state (1= locked, 0= unlocked). - PADDRDBG31=1 (upper 2GB): always returns 0. |
| IMP | 0 | ro | 0x1 | Read behavior depends on PADDRDBG31 pin: - PADDRDBG31=0 (lower 2GB): always returns 1, meaning lock mechanism are implemented. - PADDRDBG31=1 (upper 2GB): always returns 0, meaning lock mechanism is NOT implemented. |

Register ([itm](#)) ASR

Name ASR
 Relative Address 0x00000FB8
 Absolute Address 0xF8805FB8
 Width 8 bits
 Access Type ro
 Reset Value 0x00000088
 Description Authentication Status Register

Register ASR Details

| Field Name | Bits | Type | Reset Value | Description |
|------------|------|------|-------------|---|
| | 7:0 | ro | 0x88 | Value is 0b1S001N00 where S is secure non-invasive debug state and N is non-secure, non-invasive debug. |

Register ([itm](#)) DEVID

| | |
|------------------|------------|
| Name | DEVID |
| Relative Address | 0x00000FC8 |
| Absolute Address | 0xF8805FC8 |
| Width | 13 bits |
| Access Type | ro |
| Reset Value | 0x00000020 |
| Description | Device ID |

Register DEVID Details

| Field Name | Bits | Type | Reset Value | Description |
|-------------|------|------|-------------|------------------------------|
| NumStimRegs | 12:0 | ro | 0x20 | Number of stimulus registers |

Register ([itm](#)) DTIR

| | |
|------------------|---------------------------------|
| Name | DTIR |
| Relative Address | 0x00000FCC |
| Absolute Address | 0xF8805FCC |
| Width | 8 bits |
| Access Type | ro |
| Reset Value | 0x00000043 |
| Description | Device Type Identifier Register |

Register DTIR Details

| Field Name | Bits | Type | Reset Value | Description |
|------------|------|------|-------------|--|
| | 7:0 | ro | 0x43 | Indicates a Trace Source and the stimulus is devifed from bus activity |

Register ([itm](#)) PERIPHID4

| | |
|------------------|------------|
| Name | PERIPHID4 |
| Relative Address | 0x00000FD0 |
| Absolute Address | 0xF8805FD0 |
| Width | 8 bits |
| Access Type | ro |
| Reset Value | 0x00000004 |

Description Peripheral ID4

Register PERIPHID4 Details

| Field Name | Bits | Type | Reset Value | Description |
|------------|------|------|-------------|--------------------------|
| 4KB_count | 7:4 | ro | 0x0 | 4KB Count, set to 0 |
| JEP106ID | 3:0 | ro | 0x4 | JEP106 continuation code |

Register ([itm](#)) PERIPHID5

Name PERIPHID5
 Relative Address 0x00000FD4
 Absolute Address 0xF8805FD4
 Width 8 bits
 Access Type ro
 Reset Value 0x00000000
 Description Peripheral ID5

Register PERIPHID5 Details

| Field Name | Bits | Type | Reset Value | Description |
|------------|------|------|-------------|-------------|
| | 7:0 | ro | 0x0 | reserved |

Register ([itm](#)) PERIPHID6

Name PERIPHID6
 Relative Address 0x00000FD8
 Absolute Address 0xF8805FD8
 Width 8 bits
 Access Type ro
 Reset Value 0x00000000
 Description Peripheral ID6

Register PERIPHID6 Details

| Field Name | Bits | Type | Reset Value | Description |
|------------|------|------|-------------|-------------|
| | 7:0 | ro | 0x0 | reserved |

Register ([itm](#)) PERIPHID7

Name PERIPHID7
 Relative Address 0x00000FDC
 Absolute Address 0xF8805FDC
 Width 8 bits
 Access Type ro
 Reset Value 0x00000000
 Description Peripheral ID7

Register PERIPHID7 Details

| Field Name | Bits | Type | Reset Value | Description |
|------------|------|------|-------------|-------------|
| | 7:0 | ro | 0x0 | reserved |

Register ([itm](#)) PERIPHID0

Name PERIPHID0
 Relative Address 0x00000FE0
 Absolute Address 0xF8805FE0
 Width 8 bits
 Access Type ro
 Reset Value 0x00000013
 Description Peripheral ID0

Register PERIPHID0 Details

| Field Name | Bits | Type | Reset Value | Description |
|------------|------|------|-------------|-------------|
| | 7:0 | ro | 0x13 | PartNumber0 |

Register ([itm](#)) PERIPHID1

Name PERIPHID1
 Relative Address 0x00000FE4
 Absolute Address 0xF8805FE4
 Width 8 bits
 Access Type ro
 Reset Value 0x000000B9
 Description Peripheral ID1

Register PERIPHID1 Details

| Field Name | Bits | Type | Reset Value | Description |
|-------------|------|------|-------------|----------------------------|
| JEP106ID | 7:4 | ro | 0xB | JEP106 Identity Code [3:0] |
| PartNumber1 | 3:0 | ro | 0x9 | PartNumber1 |

Register ([itm](#)) PERIPHID2

| | |
|------------------|----------------|
| Name | PERIPHID2 |
| Relative Address | 0x00000FE8 |
| Absolute Address | 0xF8805FE8 |
| Width | 8 bits |
| Access Type | ro |
| Reset Value | 0x0000002B |
| Description | Peripheral ID2 |

Register PERIPHID2 Details

| Field Name | Bits | Type | Reset Value | Description |
|------------|------|------|-------------|---|
| RevNum | 7:4 | ro | 0x2 | Revision number of Peripheral |
| JEDEC | 3 | ro | 0x1 | Indicates that a JEDEC assigned value is used |
| JEP106ID | 2:0 | ro | 0x3 | JEP106 Identity Code [6:4] |

Register ([itm](#)) PERIPHID3

| | |
|------------------|----------------|
| Name | PERIPHID3 |
| Relative Address | 0x00000FEC |
| Absolute Address | 0xF8805FEC |
| Width | 8 bits |
| Access Type | ro |
| Reset Value | 0x00000000 |
| Description | Peripheral ID3 |

Register PERIPHID3 Details

| Field Name | Bits | Type | Reset Value | Description |
|------------|------|------|-------------|----------------------|
| RevAnd | 7:4 | ro | 0x0 | RevAnd, at top level |
| CustMod | 3:0 | ro | 0x0 | Customer Modified |

Register ([itm](#)) COMPID0

| | |
|------------------|---------------|
| Name | COMPID0 |
| Relative Address | 0x00000FF0 |
| Absolute Address | 0xF8805FF0 |
| Width | 8 bits |
| Access Type | ro |
| Reset Value | 0x0000000D |
| Description | Component ID0 |

Register COMPID0 Details

| Field Name | Bits | Type | Reset Value | Description |
|------------|------|------|-------------|-------------|
| | 7:0 | ro | 0xD | Preamble |

Register ([itm](#)) COMPID1

| | |
|------------------|---------------|
| Name | COMPID1 |
| Relative Address | 0x00000FF4 |
| Absolute Address | 0xF8805FF4 |
| Width | 8 bits |
| Access Type | ro |
| Reset Value | 0x00000090 |
| Description | Component ID1 |

Register COMPID1 Details

| Field Name | Bits | Type | Reset Value | Description |
|------------|------|------|-------------|-------------|
| | 7:0 | ro | 0x90 | Preamble |

Register ([itm](#)) COMPID2

| | |
|------------------|---------------|
| Name | COMPID2 |
| Relative Address | 0x00000FF8 |
| Absolute Address | 0xF8805FF8 |
| Width | 8 bits |
| Access Type | ro |
| Reset Value | 0x00000005 |
| Description | Component ID2 |

Register COMPID2 Details

| Field Name | Bits | Type | Reset Value | Description |
|------------|------|------|-------------|-------------|
| | 7:0 | ro | 0x5 | Preamble |

Register ([itm](#)) COMPID3

| | |
|------------------|---------------|
| Name | COMPID3 |
| Relative Address | 0x00000FFC |
| Absolute Address | 0xF8805FFC |
| Width | 8 bits |
| Access Type | ro |
| Reset Value | 0x000000B1 |
| Description | Component ID3 |

Register COMPID3 Details

| Field Name | Bits | Type | Reset Value | Description |
|------------|------|------|-------------|-------------|
| | 7:0 | ro | 0xB1 | Preamble |

B.15 CoreSight Trace Packet Output (tpiu)

| | |
|--------------|--------------------------------------|
| Module Name | CoreSight Trace Packet Output (tpiu) |
| Base Address | 0xF8803000 debug_tpiu |
| Description | Trace Port Interface Unit |
| Vendor Info | |

Register Summary

| Register Name | Address | Width | Type | Reset Value | Description |
|---------------------------------|------------|-------|-------|-------------|---|
| SuppSize | 0x00000000 | 32 | rw | 0xFFFFFFFF | Supported Port Size Register |
| CurrentSize | 0x00000004 | 32 | rw | 0x00000001 | Current Port Size Register |
| SuppTrigMode | 0x00000100 | 18 | ro | 0x0000011F | Supported Trigger Modes Register |
| TrigCount | 0x00000104 | 8 | rw | 0x00000000 | Trigger Counter Register |
| TrigMult | 0x00000108 | 5 | rw | 0x00000000 | Trigger Multiplier Register |
| SuppTest | 0x00000200 | 18 | ro | 0x0003000F | Supported Test Patterns/Modes Register |
| CurrentTest | 0x00000204 | 18 | mixed | 0x00000000 | Current Test Patterns/Modes Register |
| TestRepeatCount | 0x00000208 | 8 | rw | 0x00000000 | TPIU Test Pattern Repeat Counter Register |
| FFSR | 0x00000300 | 3 | ro | 0x00000006 | Formatter and Flush Status Register |
| FFCR | 0x00000304 | 14 | mixed | 0x00000000 | Formatter and Flush Control Register |
| FormatSyncCount | 0x00000308 | 12 | rw | 0x00000040 | Formatter Synchronization Counter Register |
| EXTCTLIn | 0x00000400 | 8 | ro | 0x00000000 | EXTCTL In Port |
| EXTCTLOut | 0x00000404 | 8 | rw | 0x00000000 | EXTCTL Out Port |
| ITTRFLINACK | 0x00000EE4 | 2 | wo | 0x00000000 | Integration Test Trigger In and Flush In Acknowledge Register |
| ITTRFLIN | 0x00000EE8 | 2 | ro | x | Integration Test Trigger In and Flush In Register |
| ITATBDATA0 | 0x00000EEC | 5 | ro | x | Integration Test ATB Data Register 0 |
| ITATBCTR2 | 0x00000EF0 | 2 | wo | 0x00000000 | Integration Test ATB Control Register 2 |
| ITATBCTR1 | 0x00000EF4 | 7 | ro | x | Integration Test ATB Control Register 1 |

| Register Name | Address | Width | Type | Reset Value | Description |
|---------------------------|------------|-------|------|-------------|---|
| ITATBCTR0 | 0x00000EF8 | 10 | ro | x | Integration Test ATB Control Register 0 |
| IMCR | 0x00000F00 | 1 | rw | 0x00000000 | Integration Mode Control Register |
| CTSR | 0x00000FA0 | 4 | rw | 0x0000000F | Claim Tag Set Register |
| CTCR | 0x00000FA4 | 4 | rw | 0x00000000 | Claim Tag Clear Register |
| LAR | 0x00000FB0 | 32 | wo | 0x00000000 | Lock Access Register |
| LSR | 0x00000FB4 | 3 | ro | 0x00000003 | Lock Status Register |
| ASR | 0x00000FB8 | 8 | ro | 0x00000000 | Authentication Status Register |
| DEVID | 0x00000FC8 | 12 | ro | 0x000000A0 | Device ID |
| DTIR | 0x00000FCC | 8 | ro | 0x00000011 | Device Type Identifier Register |
| PERIPHID4 | 0x00000FD0 | 8 | ro | 0x00000004 | Peripheral ID4 |
| PERIPHID5 | 0x00000FD4 | 8 | ro | 0x00000000 | Peripheral ID5 |
| PERIPHID6 | 0x00000FD8 | 8 | ro | 0x00000000 | Peripheral ID6 |
| PERIPHID7 | 0x00000FDC | 8 | ro | 0x00000000 | Peripheral ID7 |
| PERIPHID0 | 0x00000FE0 | 8 | ro | 0x00000012 | Peripheral ID0 |
| PERIPHID1 | 0x00000FE4 | 8 | ro | 0x000000B9 | Peripheral ID1 |
| PERIPHID2 | 0x00000FE8 | 8 | ro | 0x0000004B | Peripheral ID2 |
| PERIPHID3 | 0x00000FEC | 8 | ro | 0x00000000 | Peripheral ID3 |
| COMPID0 | 0x00000FF0 | 8 | ro | 0x0000000D | Component ID0 |
| COMPID1 | 0x00000FF4 | 8 | ro | 0x00000090 | Component ID1 |
| COMPID2 | 0x00000FF8 | 8 | ro | 0x00000005 | Component ID2 |
| COMPID3 | 0x00000FFC | 8 | ro | 0x000000B1 | Component ID3 |

Register ([tpiu](#)) SuppSize

| | |
|------------------|------------------------------|
| Name | SuppSize |
| Relative Address | 0x00000000 |
| Absolute Address | 0xF8803000 |
| Width | 32 bits |
| Access Type | rw |
| Reset Value | 0xFFFFFFFF |
| Description | Supported Port Size Register |

Register SuppSize Details

| Field Name | Bits | Type | Reset Value | Description |
|------------|------|------|-------------|---|
| | 31:0 | rw | 0xFFFFFFFF | Each bit location represents a single port size that is supported on the device, that is, 32-1 in bit locations [31:0]. |

Register ([tpiu](#)) CurrentSize

| | |
|------------------|----------------------------|
| Name | CurrentSize |
| Relative Address | 0x00000004 |
| Absolute Address | 0xF8803004 |
| Width | 32 bits |
| Access Type | rw |
| Reset Value | 0x00000001 |
| Description | Current Port Size Register |

Register CurrentSize Details

| Field Name | Bits | Type | Reset Value | Description |
|------------|------|------|-------------|---|
| | 31:0 | rw | 0x1 | The Current Port Size Register has the same format as the Supported Port Sizes register but only one bit is set, and all others must be zero. Writing values with more than one bit set or setting a bit that is not indicated as supported is not supported and causes unpredictable behavior. |

Register ([tpiu](#)) SuppTrigMode

| | |
|------------------|----------------------------------|
| Name | SuppTrigMode |
| Relative Address | 0x00000100 |
| Absolute Address | 0xF8803100 |
| Width | 18 bits |
| Access Type | ro |
| Reset Value | 0x0000011F |
| Description | Supported Trigger Modes Register |

Register SuppTrigMode Details

| Field Name | Bits | Type | Reset Value | Description |
|------------|------|------|-------------|---|
| TrgRun | 17 | ro | 0x0 | Trigger Counter running. A trigger has occurred but the counter is not at zero. |
| Triggered | 16 | ro | 0x0 | A trigger has occurred and the counter has reached zero. |
| reserved | 15:9 | ro | 0x0 | Reserved |
| TCount8 | 8 | ro | 0x1 | 8-bit wide counter register implemented. |
| reserved | 7:5 | ro | 0x0 | Reserved |
| Mult64k | 4 | ro | 0x1 | Multiply the Trigger Counter by 65536 supported. |
| Mult256 | 3 | ro | 0x1 | Multiply the Trigger Counter by 256 supported. |
| Mult16 | 2 | ro | 0x1 | Multiply the Trigger Counter by 16 supported. |
| Mult4 | 1 | ro | 0x1 | Multiply the Trigger Counter by 4 supported. |
| Mult2 | 0 | ro | 0x1 | Multiply the Trigger Counter by 2 supported. |

Register ([tpiu](#)) TrigCount

| | |
|------------------|--------------------------|
| Name | TrigCount |
| Relative Address | 0x00000104 |
| Absolute Address | 0xF8803104 |
| Width | 8 bits |
| Access Type | rw |
| Reset Value | 0x00000000 |
| Description | Trigger Counter Register |

Register TrigCount Details

| Field Name | Bits | Type | Reset Value | Description |
|------------|------|------|-------------|---|
| TrigCount | 7:0 | rw | 0x0 | 8-bit counter value for the number of words to be output from the formatter before a trigger is inserted. |

Register ([tpiu](#)) TrigMult

| | |
|------------------|------------|
| Name | TrigMult |
| Relative Address | 0x00000108 |
| Absolute Address | 0xF8803108 |
| Width | 5 bits |
| Access Type | rw |

Reset Value 0x00000000
 Description Trigger Multiplier Register

Register TrigMult Details

| Field Name | Bits | Type | Reset Value | Description |
|------------|------|------|-------------|--|
| Mult64k | 4 | rw | 0x0 | Multiply the Trigger Counter by 65536. |
| Mult256 | 3 | rw | 0x0 | Multiply the Trigger Counter by 256. |
| Mult16 | 2 | rw | 0x0 | Multiply the Trigger Counter by 16. |
| Mult4 | 1 | rw | 0x0 | Multiply the Trigger Counter by 4. |
| Mult2 | 0 | rw | 0x0 | Multiply the Trigger Counter by 2. |

Register ([tpiu](#)) SuppTest

Name SuppTest
 Relative Address 0x00000200
 Absolute Address 0xF8803200
 Width 18 bits
 Access Type ro
 Reset Value 0x0003000F
 Description Supported Test Patterns/Modes Register

Register SuppTest Details

| Field Name | Bits | Type | Reset Value | Description |
|------------|------|------|-------------|--------------------|
| PContEn | 17 | ro | 0x1 | Continuous mode. |
| PTimeEn | 16 | ro | 0x1 | Timed mode. |
| reserved | 15:4 | ro | 0x0 | Reserved |
| PatF0 | 3 | ro | 0x1 | FF/00 Pattern |
| PatA5 | 2 | ro | 0x1 | AA/55 Pattern |
| PatW0 | 1 | ro | 0x1 | Walking 0s Pattern |
| PatW1 | 0 | ro | 0x1 | Walking 1s Pattern |

Register ([tpiu](#)) CurrentTest

Name CurrentTest
 Relative Address 0x00000204
 Absolute Address 0xF8803204
 Width 18 bits

Access Type mixed
 Reset Value 0x00000000
 Description Current Test Patterns/Modes Register

Register CurrentTest Details

| Field Name | Bits | Type | Reset Value | Description |
|------------|------|------|-------------|--------------------|
| PContEn | 17 | rw | 0x0 | Continuous mode. |
| PTimeEn | 16 | rw | 0x0 | Timed mode. |
| reserved | 15:4 | ro | 0x0 | Reserved |
| PatF0 | 3 | rw | 0x0 | FF/00 Pattern |
| PatA5 | 2 | rw | 0x0 | AA/55 Pattern |
| PatW0 | 1 | rw | 0x0 | Walking 0s Pattern |
| PatW1 | 0 | rw | 0x0 | Walking 1s Pattern |

Register ([tpiu](#)) TestRepeatCount

Name TestRepeatCount
 Relative Address 0x00000208
 Absolute Address 0xF8803208
 Width 8 bits
 Access Type rw
 Reset Value 0x00000000
 Description TPIU Test Pattern Repeat Counter Register

Register TestRepeatCount Details

| Field Name | Bits | Type | Reset Value | Description |
|------------|------|------|-------------|---|
| PattCount | 7:0 | rw | 0x0 | 8-bit counter value to indicate the number of TRACECLKIN cycles that a pattern runs for before switching to the next pattern. |

Register ([tpiu](#)) FFSR

Name FFSR
 Relative Address 0x00000300
 Absolute Address 0xF8803300
 Width 3 bits
 Access Type ro

Reset Value 0x00000006
 Description Formatter and Flush Status Register

Register FFSR Details

| Field Name | Bits | Type | Reset Value | Description |
|------------|------|------|-------------|--|
| TCPresent | 2 | ro | 0x1 | If this bit is set then TRACECTL is present. |
| FtStopped | 1 | ro | 0x1 | Formatter stopped. The formatter has received a stop request signal and all trace data and post-amble has been output. Any more trace data on the ATB interface is ignored and ATREADY goes HIGH. |
| FlInProg | 0 | ro | 0x0 | Flush In Progress. This is an indication of the current state of AFVALIDS. |

Register ([tpiu](#)) FFCR

Name FFCR
 Relative Address 0x00000304
 Absolute Address 0xF8803304
 Width 14 bits
 Access Type mixed
 Reset Value 0x00000000
 Description Formatter and Flush Control Register

Register FFCR Details

| Field Name | Bits | Type | Reset Value | Description |
|------------|------|------|-------------|--|
| StopTrig | 13 | rw | 0x0 | Stop the formatter after a Trigger Event is observed. |
| StopFl | 12 | rw | 0x0 | Stop the formatter after a flush completes (return of AFREADY). This forces the FIFO to drain off any part-completed packets. |
| reserved | 11 | ro | 0x0 | Reserved |
| TrigFl | 10 | rw | 0x0 | Indicates a trigger on Flush completion on AFREADY being returned. |
| TrigEvt | 9 | rw | 0x0 | Indicates a trigger on a Trigger Event. |
| TrigIn | 8 | rw | 0x0 | Indicates a trigger on TRIGIN being asserted. |
| reserved | 7 | ro | 0x0 | Reserved |
| FOnMan | 6 | rw | 0x0 | Manually generate a flush of the system. Setting this bit causes a flush to be generated. This is cleared when this flush has been serviced. |

| Field Name | Bits | Type | Reset Value | Description |
|------------|------|------|-------------|--|
| FOnTrig | 5 | rw | 0x0 | Generate a flush using Trigger event. Set this bit to cause a flush of data in the system when a Trigger Event occurs. |
| FOnFlIn | 4 | rw | 0x0 | Generate flush using the FLUSHIN interface. Set this bit to enable use of the FLUSHIN connection. |
| reserved | 3:2 | ro | 0x0 | Reserved |
| EnFCont | 1 | rw | 0x0 | Continuous Formatting, no TRACECTL. Embed in trigger packets and indicate null cycles using Sync packets. Can only be changed when FtStopped is HIGH. |
| EnFTC | 0 | rw | 0x0 | Enable Formatting. Do not embed Triggers into the formatted stream. Trace disable cycles and triggers are indicated by TRACECTL, where fitted. Can only be changed when FtStopped is HIGH. |

Register ([tpiu](#)) FormatSyncCount

| | |
|------------------|--|
| Name | FormatSyncCount |
| Relative Address | 0x00000308 |
| Absolute Address | 0xF8803308 |
| Width | 12 bits |
| Access Type | rw |
| Reset Value | 0x00000040 |
| Description | Formatter Synchronization Counter Register |

Register FormatSyncCount Details

| Field Name | Bits | Type | Reset Value | Description |
|------------|------|------|-------------|--|
| CycCount | 11:0 | rw | 0x40 | 12-bit counter value to indicate the number of complete frames between full synchronization packets. |

Register ([tpiu](#)) EXTCTLIn

| | |
|------------------|----------------|
| Name | EXTCTLIn |
| Relative Address | 0x00000400 |
| Absolute Address | 0xF8803400 |
| Width | 8 bits |
| Access Type | ro |
| Reset Value | 0x00000000 |
| Description | EXTCTL In Port |

Register EXTCTLIn Details

| Field Name | Bits | Type | Reset Value | Description |
|------------|------|------|-------------|-------------|
| | 7:0 | ro | 0x0 | Tied to 0 |

Register ([tpiu](#)) EXTCTLOut

| | |
|------------------|-----------------|
| Name | EXTCTLOut |
| Relative Address | 0x00000404 |
| Absolute Address | 0xF8803404 |
| Width | 8 bits |
| Access Type | rw |
| Reset Value | 0x00000000 |
| Description | EXTCTL Out Port |

Register EXTCTLOut Details

| Field Name | Bits | Type | Reset Value | Description |
|------------|------|------|-------------|----------------------|
| | 7:0 | rw | 0x0 | Output not connected |

Register ([tpiu](#)) ITTRFLINACK

| | |
|------------------|---|
| Name | ITTRFLINACK |
| Relative Address | 0x00000EE4 |
| Absolute Address | 0xF8803EE4 |
| Width | 2 bits |
| Access Type | wo |
| Reset Value | 0x00000000 |
| Description | Integration Test Trigger In and Flush In Acknowledge Register |

Register ITTRFLINACK Details

| Field Name | Bits | Type | Reset Value | Description |
|------------|------|------|-------------|-----------------------------|
| FLUSHINACK | 1 | wo | 0x0 | Set the value of FLUSHINACK |
| TRIGINACK | 0 | wo | 0x0 | Set the value of TRIGINACK |

Register ([tpiu](#)) ITTRFLIN

| | |
|------|----------|
| Name | ITTRFLIN |
|------|----------|

Relative Address 0x00000EE8
 Absolute Address 0xF8803EE8
 Width 2 bits
 Access Type ro
 Reset Value x
 Description Integration Test Trigger In and Flush In Register

Register ITTRFLIN Details

| Field Name | Bits | Type | Reset Value | Description |
|------------|------|------|-------------|---------------------------|
| FLUSHIN | 1 | ro | x | Read the value of FLUSHIN |
| TRIGIN | 0 | ro | x | Read the value of TRIGIN |

Register ([tpiu](#)) ITATBDATA0

Name ITATBDATA0
 Relative Address 0x00000EEC
 Absolute Address 0xF8803EEC
 Width 5 bits
 Access Type ro
 Reset Value x
 Description Integration Test ATB Data Register 0

Register ITATBDATA0 Details

| Field Name | Bits | Type | Reset Value | Description |
|------------|------|------|-------------|-------------------------------|
| ATDATA31 | 4 | ro | x | Read the value of ATDATAS[31] |
| ATDATA23 | 3 | ro | x | Read the value of ATDATAS[23] |
| ATDATA15 | 2 | ro | x | Read the value of ATDATAS[15] |
| ATDATA7 | 1 | ro | x | Read the value of ATDATAS[7] |
| ATDATA0 | 0 | ro | x | Read the value of ATDATAS[0] |

Register ([tpiu](#)) ITATBCTR2

Name ITATBCTR2
 Relative Address 0x00000EF0
 Absolute Address 0xF8803EF0
 Width 2 bits
 Access Type wo

Reset Value 0x00000000
 Description Integration Test ATB Control Register 2

Register ITATBCTR2 Details

| Field Name | Bits | Type | Reset Value | Description |
|------------|------|------|-------------|---------------------------|
| AFVALID | 1 | wo | 0x0 | Set the value of AFVALIDS |
| ATREADY | 0 | wo | 0x0 | Set the value of ATREADYS |

Register ([tpiu](#)) ITATBCTR1

Name ITATBCTR1
 Relative Address 0x00000EF4
 Absolute Address 0xF8803EF4
 Width 7 bits
 Access Type ro
 Reset Value x
 Description Integration Test ATB Control Register 1

Register ITATBCTR1 Details

| Field Name | Bits | Type | Reset Value | Description |
|------------|------|------|-------------|-------------------------|
| ATID | 6:0 | ro | x | Read the value of ATIDS |

Register ([tpiu](#)) ITATBCTR0

Name ITATBCTR0
 Relative Address 0x00000EF8
 Absolute Address 0xF8803EF8
 Width 10 bits
 Access Type ro
 Reset Value x
 Description Integration Test ATB Control Register 0

Register ITATBCTR0 Details

| Field Name | Bits | Type | Reset Value | Description |
|------------|------|------|-------------|----------------------------|
| ATBYTES | 9:8 | ro | x | Read the value of ATBYTESS |
| reserved | 7:2 | ro | x | Reserved |

| Field Name | Bits | Type | Reset Value | Description |
|------------|------|------|-------------|---------------------------|
| AFREADY | 1 | ro | x | Read the value of AFREADY |
| ATVALID | 0 | ro | x | Read the value of ATVALID |

Register ([tpiu](#)) IMCR

| | |
|------------------|-----------------------------------|
| Name | IMCR |
| Relative Address | 0x00000F00 |
| Absolute Address | 0xF8803F00 |
| Width | 1 bits |
| Access Type | rw |
| Reset Value | 0x00000000 |
| Description | Integration Mode Control Register |

Register IMCR Details

| Field Name | Bits | Type | Reset Value | Description |
|------------|------|------|-------------|-----------------------------------|
| | 0 | rw | 0x0 | Enable Integration Test registers |

Register ([tpiu](#)) CTSR

| | |
|------------------|------------------------|
| Name | CTSR |
| Relative Address | 0x00000FA0 |
| Absolute Address | 0xF8803FA0 |
| Width | 4 bits |
| Access Type | rw |
| Reset Value | 0x0000000F |
| Description | Claim Tag Set Register |

Register CTSR Details

| Field Name | Bits | Type | Reset Value | Description |
|------------|------|------|-------------|---|
| | 3:0 | rw | 0xF | The claim tag register is used for any interrogating tools to determine if the device is being programmed or has been programmed. Read: 1= Claim tag is implemented, 0 = Claim tag is not implemented Write: 1= Set claim tag bit, 0= No effect |

Register ([tpiu](#)) CTCR

| | |
|------------------|--------------------------|
| Name | CTCR |
| Relative Address | 0x00000FA4 |
| Absolute Address | 0xF8803FA4 |
| Width | 4 bits |
| Access Type | rw |
| Reset Value | 0x00000000 |
| Description | Claim Tag Clear Register |

Register CTCR Details

| Field Name | Bits | Type | Reset Value | Description |
|------------|------|------|-------------|---|
| | 3:0 | rw | 0x0 | The claim tag register is used for any interrogating tools to determine if the device is being programmed or has been programmed. Read: Current value of claim tag. Write: 1= Clear claim tag bit, 0= No effect |

Register ([tpiu](#)) LAR

| | |
|------------------|----------------------|
| Name | LAR |
| Relative Address | 0x00000FB0 |
| Absolute Address | 0xF8803FB0 |
| Width | 32 bits |
| Access Type | wo |
| Reset Value | 0x00000000 |
| Description | Lock Access Register |

Register LAR Details

| Field Name | Bits | Type | Reset Value | Description |
|------------|------|------|-------------|---|
| | 31:0 | wo | 0x0 | <p>Write Access Code.</p> <p>Write behavior depends on PADDRDBG31 pin:</p> <ul style="list-style-type: none"> - PADDRDBG31=0 (lower 2GB): <p>After reset (via PRESETDBGn), TPIU is locked, i.e., writes to all other registers using lower 2GB addresses are ignored.</p> <p>To unlock, 0xC5ACCE55 must be written this register.</p> <p>After the required registers are written, to lock again, write a value other than 0xC5ACCE55 to this register.</p> <ul style="list-style-type: none"> - PADDRDBG31=1 (upper 2GB): <p>TPIU is unlocked when upper 2GB addresses are used to write to all the registers.</p> <p>However, write to this register is ignored using a upper 2GB address!</p> <p>Note: read from this register always returns 0, regardless of PADDRDBG31.</p> |

Register ([tpiu](#)) LSR

| | |
|------------------|----------------------|
| Name | LSR |
| Relative Address | 0x00000FB4 |
| Absolute Address | 0xF8803FB4 |
| Width | 3 bits |
| Access Type | ro |
| Reset Value | 0x00000003 |
| Description | Lock Status Register |

Register LSR Details

| Field Name | Bits | Type | Reset Value | Description |
|------------|------|------|-------------|--|
| 8BIT | 2 | ro | 0x0 | Set to 0 since TPIU implements a 32-bit lock access register |

| Field Name | Bits | Type | Reset Value | Description |
|------------|------|------|-------------|---|
| STATUS | 1 | ro | 0x1 | Read behavior depends on PADDRDBG31 pin: - PADDRDBG31=0 (lower 2GB): When a lower 2GB address is used to read this register, this bit indicates whether TPIU is in locked state (1= locked, 0= unlocked). - PADDRDBG31=1 (upper 2GB): always returns 0. |
| IMP | 0 | ro | 0x1 | Read behavior depends on PADDRDBG31 pin: - PADDRDBG31=0 (lower 2GB): always returns 1, meaning lock mechanism are implemented. - PADDRDBG31=1 (upper 2GB): always returns 0, meaning lock mechanism is NOT implemented. |

Register ([tpiu](#)) ASR

| | |
|------------------|--------------------------------|
| Name | ASR |
| Relative Address | 0x00000FB8 |
| Absolute Address | 0xF8803FB8 |
| Width | 8 bits |
| Access Type | ro |
| Reset Value | 0x00000000 |
| Description | Authentication Status Register |

Register ASR Details

| Field Name | Bits | Type | Reset Value | Description |
|------------|------|------|-------------|---|
| | 7:0 | ro | 0x0 | Indicates functionality not implemented |

Register ([tpiu](#)) DEVID

| | |
|------------------|------------|
| Name | DEVID |
| Relative Address | 0x00000FC8 |
| Absolute Address | 0xF8803FC8 |
| Width | 12 bits |
| Access Type | ro |
| Reset Value | 0x000000A0 |
| Description | Device ID |

Register DEVID Details

| Field Name | Bits | Type | Reset Value | Description |
|------------|------|------|-------------|--------------------------------------|
| UartNRZ | 11 | ro | 0x0 | UART/NRZ not supported |
| Manchester | 10 | ro | 0x0 | Manchester not support |
| ClockData | 9 | ro | 0x0 | Trace clock + data is supported |
| FifoSize | 8:6 | ro | 0x2 | FIFO size is 4 |
| AsyncClock | 5 | ro | 0x1 | ATCLK and TRACECLKIN is asynchronous |
| InputMux | 4:0 | ro | 0x0 | No input multiplexing |

Register ([tpiu](#)) DTIR

| | |
|------------------|---------------------------------|
| Name | DTIR |
| Relative Address | 0x00000FCC |
| Absolute Address | 0xF8803FCC |
| Width | 8 bits |
| Access Type | ro |
| Reset Value | 0x00000011 |
| Description | Device Type Identifier Register |

Register DTIR Details

| Field Name | Bits | Type | Reset Value | Description |
|------------|------|------|-------------|--------------------------------------|
| | 7:0 | ro | 0x11 | A trace sink and specifically a TPIU |

Register ([tpiu](#)) PERIPHID4

| | |
|------------------|----------------|
| Name | PERIPHID4 |
| Relative Address | 0x00000FD0 |
| Absolute Address | 0xF8803FD0 |
| Width | 8 bits |
| Access Type | ro |
| Reset Value | 0x00000004 |
| Description | Peripheral ID4 |

Register PERIPHID4 Details

| Field Name | Bits | Type | Reset Value | Description |
|------------|------|------|-------------|--------------------------|
| 4KB_count | 7:4 | ro | 0x0 | 4KB Count, set to 0 |
| JEP106ID | 3:0 | ro | 0x4 | JEP106 continuation code |

Register ([tpiu](#)) PERIPHID5

| | |
|------------------|----------------|
| Name | PERIPHID5 |
| Relative Address | 0x00000FD4 |
| Absolute Address | 0xF8803FD4 |
| Width | 8 bits |
| Access Type | ro |
| Reset Value | 0x00000000 |
| Description | Peripheral ID5 |

Register PERIPHID5 Details

| Field Name | Bits | Type | Reset Value | Description |
|------------|------|------|-------------|-------------|
| | 7:0 | ro | 0x0 | reserved |

Register ([tpiu](#)) PERIPHID6

| | |
|------------------|----------------|
| Name | PERIPHID6 |
| Relative Address | 0x00000FD8 |
| Absolute Address | 0xF8803FD8 |
| Width | 8 bits |
| Access Type | ro |
| Reset Value | 0x00000000 |
| Description | Peripheral ID6 |

Register PERIPHID6 Details

| Field Name | Bits | Type | Reset Value | Description |
|------------|------|------|-------------|-------------|
| | 7:0 | ro | 0x0 | reserved |

Register ([tpiu](#)) PERIPHID7

| | |
|------|-----------|
| Name | PERIPHID7 |
|------|-----------|

Relative Address 0x00000FDC
 Absolute Address 0xF8803FDC
 Width 8 bits
 Access Type ro
 Reset Value 0x00000000
 Description Peripheral ID7

Register PERIPHID7 Details

| Field Name | Bits | Type | Reset Value | Description |
|------------|------|------|-------------|-------------|
| | 7:0 | ro | 0x0 | reserved |

Register ([tpiu](#)) PERIPHID0

Name PERIPHID0
 Relative Address 0x00000FE0
 Absolute Address 0xF8803FE0
 Width 8 bits
 Access Type ro
 Reset Value 0x00000012
 Description Peripheral ID0

Register PERIPHID0 Details

| Field Name | Bits | Type | Reset Value | Description |
|------------|------|------|-------------|-------------|
| | 7:0 | ro | 0x12 | PartNumber0 |

Register ([tpiu](#)) PERIPHID1

Name PERIPHID1
 Relative Address 0x00000FE4
 Absolute Address 0xF8803FE4
 Width 8 bits
 Access Type ro
 Reset Value 0x000000B9
 Description Peripheral ID1

Register PERIPHID1 Details

| Field Name | Bits | Type | Reset Value | Description |
|-------------|------|------|-------------|----------------------------|
| JEP106ID | 7:4 | ro | 0xB | JEP106 Identity Code [3:0] |
| PartNumber1 | 3:0 | ro | 0x9 | PartNumber1 |

Register ([tpiu](#)) PERIPHID2

| | |
|------------------|----------------|
| Name | PERIPHID2 |
| Relative Address | 0x00000FE8 |
| Absolute Address | 0xF8803FE8 |
| Width | 8 bits |
| Access Type | ro |
| Reset Value | 0x0000004B |
| Description | Peripheral ID2 |

Register PERIPHID2 Details

| Field Name | Bits | Type | Reset Value | Description |
|------------|------|------|-------------|---|
| RevNum | 7:4 | ro | 0x4 | Revision number of Peripheral |
| JEDEC | 3 | ro | 0x1 | Indicates that a JEDEC assigned value is used |
| JEP106ID | 2:0 | ro | 0x3 | JEP106 Identity Code [6:4] |

Register ([tpiu](#)) PERIPHID3

| | |
|------------------|----------------|
| Name | PERIPHID3 |
| Relative Address | 0x00000FEC |
| Absolute Address | 0xF8803FEC |
| Width | 8 bits |
| Access Type | ro |
| Reset Value | 0x00000000 |
| Description | Peripheral ID3 |

Register PERIPHID3 Details

| Field Name | Bits | Type | Reset Value | Description |
|------------|------|------|-------------|----------------------|
| RevAnd | 7:4 | ro | 0x0 | RevAnd, at top level |
| CustMod | 3:0 | ro | 0x0 | Customer Modified |

Register ([tpiu](#)) COMPID0

| | |
|------------------|---------------|
| Name | COMPID0 |
| Relative Address | 0x00000FF0 |
| Absolute Address | 0xF8803FF0 |
| Width | 8 bits |
| Access Type | ro |
| Reset Value | 0x0000000D |
| Description | Component ID0 |

Register COMPID0 Details

| Field Name | Bits | Type | Reset Value | Description |
|------------|------|------|-------------|-------------|
| | 7:0 | ro | 0xD | Preamble |

Register ([tpiu](#)) COMPID1

| | |
|------------------|---------------|
| Name | COMPID1 |
| Relative Address | 0x00000FF4 |
| Absolute Address | 0xF8803FF4 |
| Width | 8 bits |
| Access Type | ro |
| Reset Value | 0x00000090 |
| Description | Component ID1 |

Register COMPID1 Details

| Field Name | Bits | Type | Reset Value | Description |
|------------|------|------|-------------|-------------|
| | 7:0 | ro | 0x90 | Preamble |

Register ([tpiu](#)) COMPID2

| | |
|------------------|---------------|
| Name | COMPID2 |
| Relative Address | 0x00000FF8 |
| Absolute Address | 0xF8803FF8 |
| Width | 8 bits |
| Access Type | ro |
| Reset Value | 0x00000005 |
| Description | Component ID2 |

Register COMPID2 Details

| Field Name | Bits | Type | Reset Value | Description |
|------------|------|------|-------------|-------------|
| | 7:0 | ro | 0x5 | Preamble |

Register ([tpiu](#)) COMPID3

| | |
|------------------|---------------|
| Name | COMPID3 |
| Relative Address | 0x0000FFC |
| Absolute Address | 0xF8803FFC |
| Width | 8 bits |
| Access Type | ro |
| Reset Value | 0x00000B1 |
| Description | Component ID3 |

Register COMPID3 Details

| Field Name | Bits | Type | Reset Value | Description |
|------------|------|------|-------------|-------------|
| | 7:0 | ro | 0xB1 | Preamble |

B.16 Device Configuration Interface (devcfg)

| | |
|---------------|---|
| Module Name | Device Configuration Interface (devcfg) |
| Software Name | XDCFG |
| Base Address | 0xF8007000 devcfg |
| Description | Device configuraion Interface |
| Vendor Info | |

Register Summary

| Register Name | Address | Width | Type | Reset Value | Description |
|---|------------|-------|-------|-------------|---|
| XDCFG_CTRL_OFFSET | 0x00000000 | 32 | mixed | 0x0C006000 | Control Register |
| XDCFG_LOCK_OFFSET | 0x00000004 | 32 | mixed | 0x00000000 | Locks for the Control Register. |
| XDCFG_CFG_OFFSET | 0x00000008 | 32 | rw | 0x00000508 | Configuration Register : This register contains configuration information for the AXI transfers, and other general setup. |
| XDCFG_INT_STS_OFFSET | 0x0000000C | 32 | mixed | 0x00000000 | Interrupt Status |
| XDCFG_INT_MASK_OFFSET | 0x00000010 | 32 | rw | 0xFFFFFFFF | Interrupt Mask. |
| XDCFG_STATUS_OFFSET | 0x00000014 | 32 | mixed | 0x40000820 | Miscellaneous Status. |
| XDCFG_DMA_SRC_ADDR_OFFSET | 0x00000018 | 32 | rw | 0x00000000 | DMA Source Address. |
| XDCFG_DMA_DEST_ADDR_OFFSET | 0x0000001C | 32 | rw | 0x00000000 | DMA Destination Address. |
| XDCFG_DMA_SRC_LENGTH_OFFSET | 0x00000020 | 32 | rw | 0x00000000 | DMA Source Transfer Length. |
| XDCFG_DMA_DEST_LENGTH_OFFSET | 0x00000024 | 32 | rw | 0x00000000 | DMA Destination Transfer Length. |
| XDCFG_MULTIBOOT_ADDR_POINTER_OFFSET | 0x0000002C | 13 | rw | 0x00000000 | Multi-Boot Address Pointer. |
| XDCFG_UNLOCK_OFFSET | 0x00000034 | 32 | rw | 0x00000000 | Unlock Control. |
| XDCFG_MCTRL_OFFSET | 0x00000080 | 32 | mixed | x | Miscellaneous Control. |
| XADCIF_CFG | 0x00000100 | 32 | rw | 0x00001114 | XADC Interface Configuration. |
| XADCIF_INT_STS | 0x00000104 | 32 | mixed | 0x00000200 | XADC Interface Interrupt Status. |
| XADCIF_INT_MASK | 0x00000108 | 32 | rw | 0xFFFFFFFF | XADC Interface Interrupt Mask. |
| XADCIF_MSTS | 0x0000010C | 32 | ro | 0x00000500 | XADC Interface Miscellaneous Status. |

| Register Name | Address | Width | Type | Reset Value | Description |
|--------------------------------|------------|-------|------|-------------|---------------------------------------|
| XADCIF_CMDFIFO | 0x00000110 | 32 | wo | 0x00000000 | XADC Interface Command FIFO Data Port |
| XADCIF_RDFIFO | 0x00000114 | 32 | ro | 0x00000000 | XADC Interface Data FIFO Data Port |
| XADCIF_MCTL | 0x00000118 | 32 | rw | 0x00000010 | XADC Interface Miscellaneous Control. |

Register ([devcfg](#)) XDCFG_CTRL_OFFSET

| | |
|------------------|-------------------|
| Name | XDCFG_CTRL_OFFSET |
| Software Name | CTRL |
| Relative Address | 0x00000000 |
| Absolute Address | 0xF8007000 |
| Width | 32 bits |
| Access Type | mixed |
| Reset Value | 0x0C006000 |
| Description | Control Register |

Register XDCFG_CTRL_OFFSET Details

Some of the register bits can be locked by control bits in the LOCK Register.

| Field Name | Bits | Type | Reset Value | Description |
|--|------|------|-------------|---|
| XDCFG_CTRL_FORCE_RST_MASK (FORCE_RST) | 31 | rw | 0x0 | Force the PS into secure lockdown. The secure lockdown state can only be cleared by issuing a PS_POR_B reset |
| XDCFG_CTRL_PCFG_PROG_B_MASK (PCFG_PROG_B) | 30 | rw | 0x0 | Program Signal used to reset the PL. It acts as the PROG_B signal in the PL. |
| PCFG_POR_CNT_4K | 29 | rw | 0x0 | This register controls which POR timer the PL will use for power-up. 0 - Use 64k timer 1 - Use 4k timer |
| reserved | 28 | rw | 0x0 | Reserved |

| Field Name | Bits | Type | Reset Value | Description |
|--|-------|------|-------------|---|
| XDCFG_CTRL_PCAP_PR_MASK (PCAP_PR) | 27 | rw | 0x1 | After the initial configuration of the PL, a partial reconfiguration can be performed using either the ICAP or PCAP interface. These interfaces are mutually exclusive and cannot be used simultaneously. Switching between ICAP and PCAP is possible but users should ensure that no commands or data are being transmitted or received before changing interfaces. Failure to do this could lead to unexpected behavior. This bit selects between ICAP and PCAP for PL reconfiguration. 0 - ICAP is selected for reconfiguration 1 - PCAP is selected for reconfiguration |
| XDCFG_CTRL_PCAP_MODE_MASK (PCAP_MODE) | 26 | rw | 0x1 | This bit enables the PCAP interface |
| XDCFG_CTRL_PCAP_RATE_EN_MASK (PCAP_RATE_EN) | 25 | rw | 0x0 | This bit is used to reduce the PCAP data transmission to once every 4 clock cycles. This bit MUST be set when the AES engine is being used to decrypt configuration data for either the PS or PL. Setting this bit for non-encrypted PCAP data transmission is allowed but not recommended. 0 - PCAP data transmitted every clock cycle 1 - PCAP data transmitted every 4th clock cycle (must be used for encrypted data) |
| XDCFG_CTRL_MULTIBOOT_EN_MASK (MULTIBOOT_EN) | 24 | rw | 0x0 | This bit enables multi-boot out of reset. This bit is only cleared by a PS_POR_B reset, 0 - Boot from default boot image base address 1 - Boot from multi-boot offset address |
| XDCFG_CTRL_JTAG_CHAIN_DISABLE_MASK (JTAG_CHAIN_DIS) | 23 | rw | 0x0 | This bit is used to disable the JTAG scan chain. The primary purpose is to protect the PL from unwanted JTAG accesses. The JTAG connection to the PS DAP and PL TAP will be disabled when this bit is set. |
| reserved | 22:16 | rw | 0x0 | Reserved |
| reserved | 15 | wo | 0x0 | Reserved. Do not modify. |
| reserved | 14 | rw | 0x1 | Reserved - always write with 1 |
| reserved | 13 | rw | 0x1 | Reserved - always write with 1 |

| Field Name | Bits | Type | Reset Value | Description |
|--|------|------|-------------|--|
| PCFG_AES_FUSE | 12 | rw | 0x0 | (Lockable, see 0x004, bit 4) This bit is used to select the AES key source 0 - BBRAM key 1 - eFuse key User access to this bit is restricted. The boot ROM will make the key selection and lock this bit during the initial boot sequence. This bit is only cleared by PS_POR_B reset. |
| XDCFG_CTRL_PCFG_AES_EN_MASK (PCFG_AES_EN) | 11:9 | rw | 0x0 | (Lockable, see 0x004, bit 3) This bit enables the AES engine within the PL. The three bits need to be either all 0's or 1's, any inconsistency will lead to security lockdown. 000 - Disable AES engine 111 - Enable AES engine All others - Secure lockdown User access to this bit is restricted. The boot ROM will enable the AES engine for secure boot and will always lock this bit before passing control to user code. This bit is only cleared by PS_POR_B reset. |
| XDCFG_CTRL_SEU_EN_MASK (SEU_EN) | 8 | rw | 0x0 | (Lockable, see 0x004, bit 2) This bit enables an automatic lockdown of the PS when a PL SEU is detected. 0 - Ignore SEU signal from PL 1 - Initiate secure lockdown when SEU signal received from PL This bit is sticky, once set it can only be cleared with a PS_POR_B reset. |
| XDCFG_CTRL_SEC_EN_MASK (SEC_EN) | 7 | ro | 0x0 | (Lockable, see 0x004, bit 1) This bit is used to indicate if the PS has been booted securely. 0 - PS was not booted securely 1 - PS was booted securely User access to this bit is restricted. The boot ROM will set this bit when a secure boot is initiated and will always lock the bit before passing control to user code. This bit is only cleared by PS_POR_B reset. |
| XDCFG_CTRL_SPNIDEN_MASK (SPNIDEN) | 6 | rw | 0x0 | (Lockable, see 0x004, bit 0) Secure Non-Invasive Debug Enable 0 - Disable 1 - Enable |
| XDCFG_CTRL_SPIDEN_MASK (SPIDEN) | 5 | rw | 0x0 | (Lockable, see 0x004, bit 0) Secure Invasive Debug Enable 0 - Disable 1 - Enable |

| Field Name | Bits | Type | Reset Value | Description |
|---------------------------------|------|------|-------------|---|
| XDCFG_CTRL_NIDEN_MASK (NIDEN) | 4 | rw | 0x0 | (Lockable, see 0x004, bit 0) Non-Invasive Debug Enable 0 - Disable 1 - Enable |
| XDCFG_CTRL_DBGEN_MASK (DBGEN) | 3 | rw | 0x0 | (Lockable, see 0x004, bit 0) Invasive Debug Enable 0 - Disable 1 - Enable |
| XDCFG_CTRL_DAP_EN_MASK (DAP_EN) | 2:0 | rw | 0x0 | (Lockable, see 0x004, bit 0) These bits will enable the Arm DAP. 111 - Arm DAP Enabled Others - Arm DAP will be bypassed |

Register ([devcfg](#)) XDCFG_LOCK_OFFSET

| | |
|------------------|---------------------------------|
| Name | XDCFG_LOCK_OFFSET |
| Software Name | LOCK |
| Relative Address | 0x00000004 |
| Absolute Address | 0xF8007004 |
| Width | 32 bits |
| Access Type | mixed |
| Reset Value | 0x00000000 |
| Description | Locks for the Control Register. |

Register XDCFG_LOCK_OFFSET Details

This register defines LOCK register used to lock changes in the Control Register 0x000 after configuration. All those LOCK register is set only register. The only way to clear those registers is power on reset signal.

| Field Name | Bits | Type | Reset Value | Description |
|---------------|------|------|-------------|---|
| reserved | 31:5 | rw | 0x0 | Reserved |
| AES_FUSE_LOCK | 4 | rwso | 0x0 | This bit locks the PCFG_AES_FUSE bit (CTRL[12]). 0 - Open 1 - Locked User access to this bit is restricted, the boot ROM will always set this bit prior to handing control over to user code. This bit is only cleared by a PS_POR_B reset. |

| Field Name | Bits | Type | Reset Value | Description |
|------------------------------------|------|------|-------------|---|
| XDCFG_LOCK_AES_EN_MASK (AES_EN) | 3 | rwso | 0x0 | This bit locks the PCFG_AES_EN bits (CTRL[11:9]). 0 - Open 1 - Locked User access to this bit is restricted, the boot ROM will always set this bit prior to handing control over to user code. This bit is only cleared by a PS_POR_B reset. |
| XDCFG_LOCK_SEU_MASK (SEU) | 2 | rwso | 0x0 | This bit locks the SEU_EN bit (CTRL[8]). 0 - Open 1 - Locked This bit is only cleared by a PS_POR_B reset. |
| XDCFG_LOCK_SEC_MASK (SEC) | 1 | rwso | 0x0 | This bit locks the SEC_EN bit (CTRL[7]). 0 - Open 1 - Locked User access to this bit is restricted, the boot ROM will always set this bit prior to handing control over to user code. This bit is only cleared by a PS_POR_B reset. |
| XDCFG_LOCK_DBG_MASK (DBG) | 0 | rwso | 0x0 | This bit locks the debug enable bits, SPNIDEN, SPIDEN, NIDEN, DBGEN, DAP_EN (CTRL[6:0]). 0 - Open 1 - Locked DBG_LOCK should only be used to prevent the debug access from being enabled. If DBG_LOCK is set and a soft-reset is issued, then the DAP_EN bits in the CTRL register (0x000) cannot be enabled until a power-on-reset is performed. This bit is only cleared by a PS_POR_B reset. |

Register ([devcfg](#)) XDCFG_CFG_OFFSET

| | |
|------------------|---|
| Name | XDCFG_CFG_OFFSET |
| Software Name | CFG |
| Relative Address | 0x00000008 |
| Absolute Address | 0xF8007008 |
| Width | 32 bits |
| Access Type | rw |
| Reset Value | 0x00000508 |
| Description | Configuration Register : This register contains configuration information for the AXI transfers, and other general setup. |

Register XDCFG_CFG_OFFSET Details

| Field Name | Bits | Type | Reset Value | Description |
|---|-------|------|-------------|--|
| reserved | 31:12 | rw | 0x0 | Reserved |
| XDCFG_CFG_RFIFO_TH_MASK (RFIFO_TH) | 11:10 | rw | 0x1 | These two bits define Rx FIFO level that sets interrupt flag 00 - One fourth full for read 01 - Half full for read 10 - Three fourth full for read 11 - Full for read(User could use this signal to trigger interrupt when read FIFO overflow) |
| XDCFG_CFG_WFIFO_TH_MASK (WFIFO_TH) | 9:8 | rw | 0x1 | These two bits define Tx FIFO level that sets interrupt flag 00 - One fourth empty for write 01 - Half empty for write 10 - Three fourth empty for write 11 - Empty for write |
| XDCFG_CFG_RCLK_EDGE_MASK (RCLK_EDGE) | 7 | rw | 0x0 | Read data active clock edge 0 - Falling edge 1 - Rising edge |
| XDCFG_CFG_WCLK_EDGE_MASK (WCLK_EDGE) | 6 | rw | 0x0 | Write data active clock edge 0 - Falling edge 1 - Rising edge |
| XDCFG_CFG_DISABLE_SRC_INC_MASK (DISABLE_SRC_INC) | 5 | rw | 0x0 | Disable automatic DMA AXI source address increment, if set, to allow AXI read from a keyhole address |
| XDCFG_CFG_DISABLE_DST_INC_MASK (DISABLE_DST_INC) | 4 | rw | 0x0 | Disable automatic DMA AXI destination address increment, if set, to allow AXI read from a keyhole address |
| reserved | 3 | rw | 0x1 | Reserved. Do not modify. |
| reserved | 2 | rw | 0x0 | Reserved. Do not modify. |
| reserved | 1 | rw | 0x0 | Reserved. Do not modify. |
| reserved | 0 | rw | 0x0 | Reserved. Do not modify. |

Register ([devcfg](#)) XDCFG_INT_STS_OFFSET

| | |
|------------------|----------------------|
| Name | XDCFG_INT_STS_OFFSET |
| Software Name | INT_STS |
| Relative Address | 0x0000000C |
| Absolute Address | 0xF800700C |
| Width | 32 bits |
| Access Type | mixed |

Reset Value 0x00000000
 Description Interrupt Status

Register XDCFG_INT_STS_OFFSET Details

Interrupt Status Register : This register contains interrupt status flags.

All register bits are clear on write by writing 1s to those bits, however the register bits will only be cleared if the condition that sets the interrupt flag is no longer true.

Note that individual status bits will be set if the corresponding condition is satisfied regardless of whether the interrupt mask bit in 0x010 is set.

However, external interrupt will only be generated if an interrupt status flag is set and the corresponding mask bit is not set

| Field Name | Bits | Type | Reset Value | Description |
|---|-------|------|-------------|--|
| PSS_GTS_USR_B_INT | 31 | wtc | 0x0 | Tri-state PL IO during HIZ, both edges |
| PSS_FST_CFG_B_INT | 30 | wtc | 0x0 | First configuration done, both edges |
| PSS_GPWRDWN_B_INT | 29 | wtc | 0x0 | Global power down, both edges |
| PSS_GTS_CFG_B_INT | 28 | wtc | 0x0 | Tri-state PL IO during configuration, both edges |
| PSS_CFG_RESET_B_INT | 27 | wtc | 0x0 | PL configuration reset, both edges |
| reserved | 26:24 | rw | 0x0 | Reserved |
| XDCFG_IXR_AXI_WTO_MASK (IXR_AXI_WTO) | 23 | wtc | 0x0 | AXI write address, data or response time out. AXI write is taking longer than expected (> 6144 cpu_1x clock cycles), this can be an indication of starvation |
| XDCFG_IXR_AXI_WERR_MASK (IXR_AXI_WERR) | 22 | wtc | 0x0 | AXI write response error |
| XDCFG_IXR_AXI_RTO_MASK (IXR_AXI_RTO) | 21 | wtc | 0x0 | AXI read address or response time out. AXI read is taking longer than expected (> 2048 cpu_1x clock cycles), this can be an indication of starvation |
| XDCFG_IXR_AXI_RERR_MASK (IXR_AXI_RERR) | 20 | wtc | 0x0 | AXI read response error |
| reserved | 19 | rw | 0x0 | Reserved |
| XDCFG_IXR_RX_FIFO_OVERFLOW_MASK (IXR_RX_FIFO_OV) | 18 | wtc | 0x0 | This bit is used to indicate that RX FIFO overflows. Incoming read data from PCAP will be dropped and the DEVCI DMA may enter an unrecoverable state |
| XDCFG_IXR_WR_FIFO_LEVEL_MASK (IXR_WR_FIFO_LVL) | 17 | wtc | 0x0 | Tx FIFO level < threshold, see reg 0x008 |

| Field Name | Bits | Type | Reset Value | Description |
|---|------|------|-------------|---|
| XDCFG_IXR_RD_FIFO_LVL_MASK (IXR_RD_FIFO_LVL) | 16 | wtc | 0x0 | Rx FIFO level >= threshold, see reg 0x008 |
| XDCFG_IXR_DMA_CMD_ERR_MASK (IXR_DMA_CMD_ERR) | 15 | wtc | 0x0 | Illegal DMA command |
| XDCFG_IXR_DMA_Q_OVERFLOW_MASK (IXR_DMA_Q_OV) | 14 | wtc | 0x0 | DMA command queue overflows |
| XDCFG_IXR_DMA_DONE_MASK (IXR_DMA_DONE) | 13 | wtc | 0x0 | This bit is used to indicate a DMA command is done. The bit is set either as soon as DMA is done (PCAP may not be finished) or both DMA and PCAP are done. |
| XDCFG_IXR_D_P_DONE_MASK (IXR_D_P_DONE) | 12 | wtc | 0x0 | Both DMA and PCAP transfers are done for intermediate and final transfers. |
| XDCFG_IXR_P2D_LEN_ERROR_MASK (IXR_P2D_LEN_ERR) | 11 | wtc | 0x0 | Inconsistent PCAP to DMA transfer length error |
| reserved | 10:7 | rw | 0x0 | Reserved |
| XDCFG_IXR_PCFG_HMAC_ERR_MASK (IXR_PCFG_HMAC_ERR) | 6 | wtc | 0x0 | Triggers when an HMAC error is received from the PL |
| XDCFG_IXR_PCFG_SEU_ERR_MASK (IXR_PCFG_SEU_ERR) | 5 | wtc | 0x0 | Triggers when PL detects POST_CRC or ECC error. |
| XDCFG_IXR_PCFG_POR_B_MASK (IXR_PCFG_POR_B) | 4 | wtc | 0x0 | Triggers if the PL loses power, PL POR_B signal goes low |
| XDCFG_IXR_PCFG_CFG_RST_MASK (IXR_PCFG_CFG_RST) | 3 | wtc | 0x0 | Triggers if the PL configuration controller is under reset |
| XDCFG_IXR_PCFG_DONE_MASK (IXR_PCFG_DONE) | 2 | wtc | 0x0 | DONE signal from PL indicating that programming is complete and PL is in user mode. |
| XDCFG_IXR_PCFG_INIT_PE_MASK (IXR_PCFG_INIT_PE) | 1 | wtc | 0x0 | Triggered on the positive edge of the PL INIT signal |
| XDCFG_IXR_PCFG_INIT_NE_MASK (IXR_PCFG_INIT_NE) | 0 | wtc | 0x0 | Triggered on the negative edge of the PL INIT signal |

Register ([devcfg](#)) XDCFG_INT_MASK_OFFSET

| | |
|------------------|-----------------------|
| Name | XDCFG_INT_MASK_OFFSET |
| Software Name | INT_MASK |
| Relative Address | 0x00000010 |
| Absolute Address | 0xF8007010 |
| Width | 32 bits |
| Access Type | rw |
| Reset Value | 0xFFFFFFFF |
| Description | Interrupt Mask. |

Register XDCFG_INT_MASK_OFFSET Details

Interrupt Mask Register: This register contains interrupt mask information.

Set a bit to 1 to mask the interrupt generation from the corresponding interrupting source in Interrupt Status Register 0x00C.

| Field Name | Bits | Type | Reset Value | Description |
|--|-------|------|-------------|--|
| M_PSS_GTS_USR_B_INT | 31 | rw | 0x1 | Interrupt mask for tri-state IO during HIZ, both edges |
| M_PSS_FST_CFG_B_INT | 30 | rw | 0x1 | Interrupt mask for first config done, both edges |
| M_PSS_GPWRDWN_B_INT | 29 | rw | 0x1 | Interrupt mask for global power down, both edges |
| M_PSS_GTS_CFG_B_INT | 28 | rw | 0x1 | Interrupt mask for tri-state IO in config, both edges |
| M_PSS_CFG_RESET_B_INT | 27 | rw | 0x1 | Interrupt mask for config reset, both edges |
| reserved | 26:24 | rw | 0x7 | Reserved |
| XDCFG_IXR_AXI_WTO_MASK (IXR_AXI_WTO) | 23 | rw | 0x1 | Interrupt mask for AXI write time out interrupt |
| XDCFG_IXR_AXI_WERR_MASK (IXR_AXI_WERR) | 22 | rw | 0x1 | Interrupt mask for AXI write response error interrupt |
| XDCFG_IXR_AXI_RTO_MASK (IXR_AXI_RTO) | 21 | rw | 0x1 | Interrupt mask for AXI read time out interrupt |
| XDCFG_IXR_AXI_RERR_MASK (IXR_AXI_RERR) | 20 | rw | 0x1 | Interrupt mask for AXI read response error interrupt |
| reserved | 19 | rw | 0x1 | Reserved |

| Field Name | Bits | Type | Reset Value | Description |
|--|------|------|-------------|---|
| XDCFG_IXR_RX_FIFO_OVERFLOW_MASK (IXR_RX_FIFO_OV) | 18 | rw | 0x1 | Interrupt mask for Rx FIFO overflow interrupt |
| XDCFG_IXR_WR_FIFO_LEVEL_MASK (IXR_WR_FIFO_LVL) | 17 | rw | 0x1 | Interrupt mask for Tx FIFO level < threshold interrupt |
| XDCFG_IXR_RD_FIFO_LEVEL_MASK (IXR_RD_FIFO_LVL) | 16 | rw | 0x1 | Interrupt mask for Rx FIFO level > threshold interrupt |
| XDCFG_IXR_DMA_COMMAND_ERROR_MASK (IXR_DMA_CMD_ERR) | 15 | rw | 0x1 | Interrupt mask for illegal DMA command interrupt |
| XDCFG_IXR_DMA_COMMAND_FIFO_OVERFLOW_MASK (IXR_DMA_Q_OV) | 14 | rw | 0x1 | Interrupt mask for DMA command FIFO overflows |
| XDCFG_IXR_DMA_COMMAND_DONE_MASK (IXR_DMA_DONE) | 13 | rw | 0x1 | Interrupt mask for DMA command done interrupt |
| XDCFG_IXR_DMA_AND_PCAP_DONE_MASK (IXR_D_P_DONE) | 12 | rw | 0x1 | Interrupt mask for DMA and PCAP done interrupt |
| XDCFG_IXR_P2D_LENGTH_ERROR_MASK (IXR_P2D_LEN_ERR) | 11 | rw | 0x1 | Interrupt mask Inconsistent xfer length error interrupt |
| reserved | 10:7 | rw | 0xF | Reserved |
| XDCFG_IXR_PCFG_HMAC_ERROR_MASK (IXR_PCFG_HMAC_ERR) | 6 | rw | 0x1 | Interrupt mask for HMAC error |
| XDCFG_IXR_PCFG_SEU_ERROR_MASK (IXR_PCFG_SEU_ERR) | 5 | rw | 0x1 | Interrupt mask for PCFG_SEU_ERR interrupt |
| XDCFG_IXR_PCFG_POR_B_MASK (IXR_PCFG_POR_B) | 4 | rw | 0x1 | Interrupt mask for PCFG_POR_B Interrupt |
| XDCFG_IXR_PCFG_CFG_RST_MASK (IXR_PCFG_CFG_RST) | 3 | rw | 0x1 | Interrupt mask for PCFG_CFG_RESET interrupt |
| XDCFG_IXR_PCFG_DONE_MASK (IXR_PCFG_DONE) | 2 | rw | 0x1 | Interrupt mask for PCFG_DONE interrupt |

| Field Name | Bits | Type | Reset Value | Description |
|---|------|------|-------------|---|
| XDCFG_IXR_PCFG_INIT_PE_MASK (IXR_PCFG_INIT_PE) | 1 | rw | 0x1 | Interrupt mask for PCFG_INIT_PE interrupt |
| XDCFG_IXR_PCFG_INIT_NE_MASK (IXR_PCFG_INIT_NE) | 0 | rw | 0x1 | Interrupt mask for PCFG_INIT_NE interrupt |

Register ([devcfg](#)) XDCFG_STATUS_OFFSET

| | |
|------------------|-----------------------|
| Name | XDCFG_STATUS_OFFSET |
| Software Name | STATUS |
| Relative Address | 0x00000014 |
| Absolute Address | 0xF8007014 |
| Width | 32 bits |
| Access Type | mixed |
| Reset Value | 0x40000820 |
| Description | Miscellaneous Status. |

Register XDCFG_STATUS_OFFSET Details

This register contains miscellaneous status.

| Field Name | Bits | Type | Reset Value | Description |
|--|-------|------------|-------------|--|
| XDCFG_STATUS_DMA_CMD_Q_F_MASK (DMA_CMD_Q_F) | 31 | ro | 0x0 | DMA command queue full, if set |
| XDCFG_STATUS_DMA_CMD_Q_E_MASK (DMA_CMD_Q_E) | 30 | ro | 0x1 | DMA command queue empty, if set |
| XDCFG_STATUS_DMA_DONE_CNT_MASK (DMA_DONE_CNT) | 29:28 | clon wr | 0x0 | Number of completed DMA transfers that have not been acknowledged by software: 00 - all finished transfers have been acknowledged 01 - one finished transfer outstanding 10 - two finished transfers outstanding 11 - three or more finished transfers outstanding A finished transfer is acknowledged by clearing the DMA_DONE_INT interrupt status flag of the interrupt status register 0x00C. This count is cleared by writing a 1 to either bit location. |
| reserved | 27:25 | rw | 0x0 | Reserved |

| Field Name | Bits | Type | Reset Value | Description |
|--|-------|------|-------------|--|
| XDCFG_STATUS_RX_FIFO_LVL_MASK (RX_FIFO_LVL) | 24:20 | ro | 0x0 | This register is used to indicate how many valid 32-Bit words in the Rx FIFO, max. is 31 |
| reserved | 19 | rw | 0x0 | Reserved |
| XDCFG_STATUS_TX_FIFO_LVL_MASK (TX_FIFO_LVL) | 18:12 | ro | 0x0 | This register is used to indicate how many valid 32-Bit words in the Tx FIFO, max. is 127 |
| PSS_GTS_USR_B | 11 | ro | 0x1 | Tri-state IO during HIZ, active low |
| PSS_FST_CFG_B | 10 | ro | 0x0 | First PL configuration done, active low. |
| PSS_GPWRDWN_B | 9 | ro | 0x0 | Global power down, active low |
| PSS_GTS_CFG_B | 8 | ro | 0x0 | Tri-state IO during config, active low. This signal will only be low when the PL CFG block is being used to configure the PL. 0 - IO are tri-stated by CFG block |
| XDCFG_STATUS_SECURE_RST_MASK (SECURE_RST) | 7 | ro | 0x0 | This bit is used to indicate a secure lockdown. Can only be cleared by a PS_POR_B reset. |
| XDCFG_STATUS_ILLEGAL_APB_ACCESS_MASK (ILLEGAL_APB_ACCESS) | 6 | ro | 0x0 | Indicates the UNLOCK register was not written with the correct unlock word. If set all secure boot features will be disabled, the DAP will be disabled and writing to the DEVCI registers will be disabled. The illegal access mode can only be cleared with a PS_POR_B reset. |
| PSS_CFG_RESET_B | 5 | ro | 0x1 | PL configuration reset, active low. |
| XDCFG_STATUS_PCFG_INIT_MASK (PCFG_INIT) | 4 | ro | 0x0 | PL INIT signal, indicates when housecleaning is done and the PL is ready to receive PCAP data. Positive and negative edges of the signal generate maskable interrupts in 0x00C. |
| XDCFG_STATUS_EFUSE_SW_RESERVE_MASK (EFUSE_SW_RESERVE) | 3 | ro | 0x0 | When this eFuse is blown, the BBRAM AES key is disabled. If the device is booted securely, the eFuse key must be used. |
| XDCFG_STATUS_EFUSE_SEC_EN_MASK (EFUSE_SEC_EN) | 2 | ro | 0x0 | When this eFuse is blown, the Zynq device must boot securely and use the eFuse as the AES key source. Non-secure boot will cause a security lockdown. |
| XDCFG_STATUS_EFUSE_JTAG_DIS_MASK (EFUSE_JTAG_DIS) | 1 | ro | 0x0 | When this eFuse is blown, the Arm DAP controller is permanently set in bypass mode. Any attempt to activate the DAP will cause a security lockdown. |
| reserved | 0 | ro | 0x0 | Reserved. Do not modify. |

Register ([devcfg](#)) XDCFG_DMA_SRC_ADDR_OFFSET

| | |
|------------------|---------------------------|
| Name | XDCFG_DMA_SRC_ADDR_OFFSET |
| Software Name | DMA_SRC_ADDR |
| Relative Address | 0x00000018 |
| Absolute Address | 0xF8007018 |
| Width | 32 bits |
| Access Type | rw |
| Reset Value | 0x00000000 |
| Description | DMA Source Address. |

Register XDCFG_DMA_SRC_ADDR_OFFSET Details

DMA Source address Register: This register contains the source address for DMA transfer.

A DMA command consists of source address, destination address, source transfer length, and destination transfer length.

It is important that the parameters are programmed in the exact sequence as described

| Field Name | Bits | Type | Reset Value | Description |
|------------|------|------|-------------|---|
| SRC_ADDR | 31:0 | rw | 0x0 | Source address for DMA transfer of AXI read. Setting SRC_ADDR[1:0] and DST_ADDR[1:0] to 2'b01 will cause the DMA engine to hold the DMA DONE interrupt until both the AXI and PCAP interfaces are done with the data transfer. Otherwise the interrupt will trigger as soon as the AXI interface is done. |

Register ([devcfg](#)) XDCFG_DMA_DEST_ADDR_OFFSET

| | |
|------------------|----------------------------|
| Name | XDCFG_DMA_DEST_ADDR_OFFSET |
| Software Name | DMA_DEST_ADDR |
| Relative Address | 0x0000001C |
| Absolute Address | 0xF800701C |
| Width | 32 bits |
| Access Type | rw |
| Reset Value | 0x00000000 |
| Description | DMA Destination Address. |

Register XDCFG_DMA_DEST_ADDR_OFFSET Details

DMA Destination address Register: This register contains the destination address for DMA transfer.

A DMA command consists of source address, destination address, source transfer length, and destination transfer length.

It is important that the parameters are programmed in the exact sequence as described.

| Field Name | Bits | Type | Reset Value | Description |
|------------|------|------|-------------|---|
| DST_ADDR | 31:0 | rw | 0x0 | Destination address for DMA transfer of AXI write. Setting SRC_ADDR[1:0] and DST_ADDR[1:0] to 2'b01 will cause the DMA engine to hold the DMA DONE interrupt until both the AXI and PCAP interfaces are done with the data transfer. Otherwise the interrupt will trigger as soon as the AXI interface is done. |

Register ([devcfg](#)) XDCFG_DMA_SRC_LEN_OFFSET

| | |
|------------------|-----------------------------|
| Name | XDCFG_DMA_SRC_LEN_OFFSET |
| Software Name | DMA_SRC_LEN |
| Relative Address | 0x00000020 |
| Absolute Address | 0xF8007020 |
| Width | 32 bits |
| Access Type | rw |
| Reset Value | 0x00000000 |
| Description | DMA Source Transfer Length. |

Register XDCFG_DMA_SRC_LEN_OFFSET Details

DMA Source transfer Length Register: This register contains the DMA source transfer length in unit of 4-byte word.

A DMA command that consists of source address, destination address, source transfer length, and destination transfer length.

It is important that the parameters are programmed in the exact sequence as described.

| Field Name | Bits | Type | Reset Value | Description |
|------------------------------|-------|------|-------------|------------------|
| reserved | 31:27 | rw | 0x0 | Reserved |
| XDCFG_DMA_LEN_MASK (DMA_LEN) | 26:0 | rw | 0x0 | Up to 512MB data |

Register ([devcfg](#)) XDCFG_DMA_DEST_LEN_OFFSET

| | |
|---------------|---------------------------|
| Name | XDCFG_DMA_DEST_LEN_OFFSET |
| Software Name | DMA_DEST_LEN |

| | |
|------------------|----------------------------------|
| Relative Address | 0x00000024 |
| Absolute Address | 0xF8007024 |
| Width | 32 bits |
| Access Type | rw |
| Reset Value | 0x00000000 |
| Description | DMA Destination Transfer Length. |

Register XDCFG_DMA_DEST_LEN_OFFSET Details

DMA Destination transfer Length Register: This register contains the DMA destination transfer length in unit of 4-byte word.

A DMA command that consists of source address, destination address, source transfer length, and destination transfer length is accepted when this register is written to.

It is important that the parameters are programmed in the exact sequence as described.

| Field Name | Bits | Type | Reset Value | Description |
|------------------------------|-------|------|-------------|------------------|
| reserved | 31:27 | rw | 0x0 | Reserved |
| XDCFG_DMA_LEN_MASK (DMA_LEN) | 26:0 | rw | 0x0 | Up to 512MB data |

Register ([devcfg](#)) XDCFG_MULTIBOOT_ADDR_OFFSET

| | |
|------------------|-----------------------------|
| Name | XDCFG_MULTIBOOT_ADDR_OFFSET |
| Software Name | MULTIBOOT_ADDR |
| Relative Address | 0x0000002C |
| Absolute Address | 0xF800702C |
| Width | 13 bits |
| Access Type | rw |
| Reset Value | 0x00000000 |
| Description | Multi-Boot Address Pointer. |

Register XDCFG_MULTIBOOT_ADDR_OFFSET Details

MULTI Boot Addr Pointer Register: This register defines multi-boot address pointer. This register is power on reset only used to remember multi-boot address pointer set by previous boot.

| Field Name | Bits | Type | Reset Value | Description |
|----------------|------|------|-------------|---------------------------|
| MULTIBOOT_ADDR | 12:0 | rw | 0x0 | Multi-Boot offset address |

Register ([devcfg](#)) XDCFG_UNLOCK_OFFSET

| | |
|------------------|---------------------|
| Name | XDCFG_UNLOCK_OFFSET |
| Software Name | UNLOCK |
| Relative Address | 0x00000034 |
| Absolute Address | 0xF8007034 |
| Width | 32 bits |
| Access Type | rw |
| Reset Value | 0x00000000 |
| Description | Unlock Control. |

Register XDCFG_UNLOCK_OFFSET Details

Unlock Register: This register is used to protect the DEVC1 configuration registers from ROM code corruption.

The boot ROM will unlock the DEVC1 by writing 0x757BDF0D to this register.

Writing anything other than the unlock word to this register will cause an illegal access state and make the DEVC1 inaccessible until a system reset occurs.

| Field Name | Bits | Type | Reset Value | Description |
|------------|------|------|-------------|---------------|
| UNLOCK | 31:0 | rw | 0x0 | Unlock value. |

Register ([devcfg](#)) XDCFG_MCTRL_OFFSET

| | |
|------------------|------------------------|
| Name | XDCFG_MCTRL_OFFSET |
| Software Name | MCTRL |
| Relative Address | 0x00000080 |
| Absolute Address | 0xF8007080 |
| Width | 32 bits |
| Access Type | mixed |
| Reset Value | x |
| Description | Miscellaneous Control. |

Register XDCFG_MCTRL_OFFSET Details

Miscellaneous control Register: This register contains miscellaneous controls.

| Field Name | Bits | Type | Reset Value | Description |
|---|-------|------|-------------|--|
| PS_VERSION | 31:28 | ro | x | Version ID for silicon 0x0 = 1.0 Silicon 0x1 = 2.0 Silicon 0x2 = 3.0 Silicon 0x3 = 3.1 Silicon |
| reserved | 27 | ro | 0x0 | Reserved. Do not modify. |
| reserved | 26 | ro | 0x0 | Reserved. Do not modify. |
| reserved | 25 | ro | 0x0 | Reserved. Do not modify. |
| reserved | 24 | ro | 0x0 | Reserved. Do not modify. |
| reserved | 23 | rw | 0x1 | Reserved - always write with 1 |
| reserved | 22:14 | rw | 0x0 | Reserved |
| reserved | 13 | rw | 0x0 | Reserved. Do not modify. |
| reserved | 12 | rw | 0x0 | Reserved. Do not modify. |
| reserved | 11:9 | rw | 0x0 | Reserved |
| PCFG_POR_B | 8 | ro | 0x0 | PL POR_B signal used to determine power-up status of PL. |
| reserved | 7:5 | rw | 0x0 | Reserved |
| XDCFG_MCTRL_PCAP_L PBK_MASK (PCAP_LPBK) | 4 | rw | 0x0 | Internal PCAP loopback, if set |
| reserved | 3:2 | rw | 0x0 | Reserved |
| reserved | 1 | rw | 0x0 | Reserved - always write with 0 |
| reserved | 0 | rw | 0x0 | Reserved - always write with 0 |

Register ([devcfg](#)) XADCIF_CFG

| | |
|------------------|-------------------------------|
| Name | XADCIF_CFG |
| Relative Address | 0x00000100 |
| Absolute Address | 0xF8007100 |
| Width | 32 bits |
| Access Type | rw |
| Reset Value | 0x00001114 |
| Description | XADC Interface Configuration. |

Register XADCIF_CFG Details

XADC Interface Configuration Register : This register configures the XADC Interface operation

| Field Name | Bits | Type | Reset Value | Description |
|------------|-------|------|-------------|---|
| ENABLE | 31 | rw | 0x0 | Enable PS access of the XADC, if set |
| reserved | 30:24 | rw | 0x0 | Reserved |
| CFIFOTH | 23:20 | rw | 0x0 | Command FIFO level threshold. Interrupt status flag is set if the FIFO level is less than or equal to the threshold |
| DFIFOTH | 19:16 | rw | 0x0 | Data FIFO level threshold. Interrupt status flag is set if FIFO level is greater than the threshold |
| reserved | 15:14 | rw | 0x0 | Reserved |
| WEDGE | 13 | rw | 0x0 | Write launch edge : 0 - Falling edge 1 - Rising edge |
| REDGE | 12 | rw | 0x1 | Read capture edge : 0 - Falling edge 1 - Rising edge |
| reserved | 11:10 | rw | 0x0 | Reserved |
| TCKRATE | 9:8 | rw | 0x1 | XADC clock frequency control. The base frequency is pcap_2x clock which has a nominal frequency of 200 MHz. 00 - 1/2 of pcap_2x clock frequency 01 - 1/4 of pcap_2x clock frequency 10 - 1/8 of pcap_2x clock frequency 11 - 1/16 of pcap_2x clock frequency |
| reserved | 7:5 | rw | 0x0 | Reserved |
| IGAP | 4:0 | rw | 0x14 | Minimum idle gap between successive commands. Default is 20 cycles, the minimum required by the XADC is 10. |

Register ([devcfg](#)) XADCIF_INT_STS

| | |
|------------------|----------------------------------|
| Name | XADCIF_INT_STS |
| Relative Address | 0x00000104 |
| Absolute Address | 0xF8007104 |
| Width | 32 bits |
| Access Type | mixed |
| Reset Value | 0x00000200 |
| Description | XADC Interface Interrupt Status. |

Register XADCIF_INT_STS Details

XADC Interface Interrupt Status Register : This register contains the interrupt status flags of the XADC interface block.

All register bits are clear on write by writing 1s to those bits, however the register bits will only be cleared if the condition that sets the interrupt flag is no longer true.

Note that individual status bits will be set if the corresponding condition is satisfied regardless of whether the interrupt mask bit in 0x108 is set.

However, external interrupt will only be generated if an interrupt status flag is set and the corresponding mask bit is not set

| Field Name | Bits | Type | Reset Value | Description |
|------------|-------|------|-------------|---|
| reserved | 31:10 | rw | 0x0 | Reserved |
| CFIFO_LTH | 9 | wtc | 0x1 | Command FIFO level less than or equal to the threshold (see register 0x100). |
| DFIFO_GTH | 8 | wtc | 0x0 | Data FIFO level greater than threshold (see register 0x100). |
| OT | 7 | wtc | 0x0 | Over temperature alarm from XADC. This is a latched version of the raw signal which is also available in register 0x10C |
| ALM | 6:0 | wtc | 0x0 | Alarm signals from XADC. These are latched version of the raw input alarm signals which are also available in register 0x10C |

Register ([devcfg](#)) XADCIF_INT_MASK

| | |
|------------------|--------------------------------|
| Name | XADCIF_INT_MASK |
| Relative Address | 0x00000108 |
| Absolute Address | 0xF8007108 |
| Width | 32 bits |
| Access Type | rw |
| Reset Value | 0xFFFFFFFF |
| Description | XADC Interface Interrupt Mask. |

Register XADCIF_INT_MASK Details

XADC Interface Interrupt Mask Register : This register contains the interrupt mask information.

Set a bit to 1 to mask the interrupt generation from the corresponding interrupting source in 0x104

| Field Name | Bits | Type | Reset Value | Description |
|-------------|-------|------|-------------|--|
| reserved | 31:10 | rw | 0x3FFFFFF | Reserved |
| M_CFIFO_LTH | 9 | rw | 0x1 | Interrupt mask for command FIFO level threshold interrupt. |
| M_DFIFO_GTH | 8 | rw | 0x1 | Interrupt mask Data FIFO level greater than threshold interrupt. |
| M_OT | 7 | rw | 0x1 | Interrupt mask for over temperature alarm interrupt |
| M_ALM | 6:0 | rw | 0x7F | Interrupt mask for alarm signals from XADC. |

Register ([devcfg](#)) XADCIF_MSTS

| | |
|------------------|--------------------------------------|
| Name | XADCIF_MSTS |
| Relative Address | 0x0000010C |
| Absolute Address | 0xF800710C |
| Width | 32 bits |
| Access Type | ro |
| Reset Value | 0x00000500 |
| Description | XADC Interface Miscellaneous Status. |

Register XADCIF_MSTS Details

XADC Interface miscellaneous Status Register : This register contains miscellaneous status of the XADC Interface

| Field Name | Bits | Type | Reset Value | Description |
|------------|-------|------|-------------|--|
| reserved | 31:20 | ro | 0x0 | Reserved |
| CFIFO_LVL | 19:16 | ro | 0x0 | Command FIFO level. |
| DFIFO_LVL | 15:12 | ro | 0x0 | Data FIFO level. |
| CFIFO_F | 11 | ro | 0x0 | Command FIFO full. |
| CFIFO_E | 10 | ro | 0x1 | Command FIFO empty. |
| DFIFO_F | 9 | ro | 0x0 | Data FIFO full. |
| DFIFO_E | 8 | ro | 0x1 | Data FIFO empty. |
| OT | 7 | ro | 0x0 | Raw over temperature alarm from the XADC. Latched version of the signal is available in the interrupt status register. |
| ALM | 6:0 | ro | 0x0 | Raw alarm signals from the XADC. Latched version of the signals are available in the interrupt status register. |

Register ([devcfg](#)) XADCIF_CMDFIFO

| | |
|------------------|---------------------------------------|
| Name | XADCIF_CMDFIFO |
| Relative Address | 0x00000110 |
| Absolute Address | 0xF8007110 |
| Width | 32 bits |
| Access Type | wo |
| Reset Value | 0x00000000 |
| Description | XADC Interface Command FIFO Data Port |

Register XADCIF_CMDFIFO Details

XADC Interface Command FIFO Register : This address is the entry point to the command FIFO. Commands get push into the FIFO when there is a write to this address

| Field Name | Bits | Type | Reset Value | Description |
|------------|------|------|-------------|-----------------|
| CMD | 31:0 | wo | 0x0 | 32-bit command. |

Register ([devcfg](#)) XADCIF_RDFIFO

| | |
|------------------|------------------------------------|
| Name | XADCIF_RDFIFO |
| Relative Address | 0x00000114 |
| Absolute Address | 0xF8007114 |
| Width | 32 bits |
| Access Type | ro |
| Reset Value | 0x00000000 |
| Description | XADC Interface Data FIFO Data Port |

Register XADCIF_RDFIFO Details

XADC Interface Data FIFO Register : This address is the exit point of the read data FIFO. Read data is returned when there is a read from this address

| Field Name | Bits | Type | Reset Value | Description |
|------------|------|------|-------------|-------------------|
| RDDATA | 31:0 | ro | 0x0 | 32-bit read data. |

Register ([devcfg](#)) XADCIF_MCTL

| | |
|------------------|-------------|
| Name | XADCIF_MCTL |
| Relative Address | 0x00000118 |

Absolute Address 0xF8007118
 Width 32 bits
 Access Type rw
 Reset Value 0x00000010
 Description XADC Interface Miscellaneous Control.

Register XADCIF_MCTL Details

XADC Interface Miscellaneous Control Register : This register provides miscellaneous control of the XADC Interface.

| Field Name | Bits | Type | Reset Value | Description |
|------------|------|------|-------------|--|
| reserved | 31:5 | rw | 0x0 | Reserved |
| RESET | 4 | rw | 0x1 | This bit will reset the communication channel between the PS and XADC. If set, the PS-XADC communication channel will remain in reset until a 0 is written to this bit. |
| reserved | 3:1 | rw | 0x0 | Reserved |
| reserved | 0 | rw | 0x0 | Reserved - always write with 0 |

B.17 DMA Controller (dmac)

| | |
|---------------|---|
| Module Name | DMA Controller (dmac) |
| Software Name | XDMAPS |
| Base Address | 0xF8004000 dmac0_ns 0xF8003000 dmac0_s |
| Description | Direct Memory Access Controller, PL330 |
| Vendor Info | Arm PL330 |

Register Summary

| Register Name | Address | Width | Type | Reset Value | Description |
|---|------------|-------|-------|-------------|-------------------------------------|
| XDMAPS_DS_OFFSET | 0x00000000 | 32 | mixed | 0x00000000 | DMA Manager Status |
| XDMAPS_DPC_OFFSET | 0x00000004 | 32 | mixed | 0x00000000 | DMA Program Counter |
| XDMAPS_INTEN_OFFSET | 0x00000020 | 32 | mixed | 0x00000000 | DMASEV Instruction Response Control |
| XDMAPS_ES_OFFSET | 0x00000024 | 32 | mixed | 0x00000000 | Event Interrupt Raw Status |
| XDMAPS_INTSTATUS_OFFSET | 0x00000028 | 32 | mixed | 0x00000000 | Interrupt Status |
| XDMAPS_INTCLR_OFFSET | 0x0000002C | 32 | mixed | 0x00000000 | Interrupt Clear |
| XDMAPS_FSM_OFFSET | 0x00000030 | 32 | mixed | 0x00000000 | Fault Status DMA Manager |
| XDMAPS_FSC_OFFSET | 0x00000034 | 32 | mixed | 0x00000000 | Fault Status DMA Channel |
| XDMAPS_FTM_OFFSET | 0x00000038 | 32 | mixed | 0x00000000 | Fault Type DMA Manager |
| XDMAPS_FTC0_OFFSET | 0x00000040 | 32 | mixed | 0x00000000 | Default Type DMA Channel 0 |
| XDmaPs_FTCn_OFFSET_1 | 0x00000044 | 32 | mixed | 0x00000000 | Default Type DMA Channel 1 |
| XDmaPs_FTCn_OFFSET_2 | 0x00000048 | 32 | mixed | 0x00000000 | Default Type DMA Channel 2 |
| XDmaPs_FTCn_OFFSET_3 | 0x0000004C | 32 | mixed | 0x00000000 | Default Type DMA Channel 3 |
| XDmaPs_FTCn_OFFSET_4 | 0x00000050 | 32 | mixed | 0x00000000 | Default Type DMA Channel 4 |
| XDmaPs_FTCn_OFFSET_5 | 0x00000054 | 32 | mixed | 0x00000000 | Default Type DMA Channel 5 |
| XDmaPs_FTCn_OFFSET_6 | 0x00000058 | 32 | mixed | 0x00000000 | Default Type DMA Channel 6 |
| XDmaPs_FTCn_OFFSET_7 | 0x0000005C | 32 | mixed | 0x00000000 | Default Type DMA Channel 7 |
| XDMAPS_CS0_OFFSET | 0x00000100 | 32 | mixed | 0x00000000 | Channel Status DMA Channel 0 |

| Register Name | Address | Width | Type | Reset Value | Description |
|---------------------------------------|------------|-------|-------|---|--------------------------------|
| XDMAPS_CPC0_OFFSET | 0x00000104 | 32 | mixed | 0x00000000 | Channel PC for DMA Channel 0 |
| XDmaPs_CSn_OFFSET_1 | 0x00000108 | 32 | mixed | 0x00000000 | Channel Status DMA Channel 1 |
| XDmaPs_CPCn_OFFSET_1 | 0x0000010C | 32 | mixed | 0x00000000 | Channel PC for DMA Channel 1 |
| XDmaPs_CSn_OFFSET_2 | 0x00000110 | 32 | mixed | 0x00000000 | Channel Status DMA Channel 2 |
| XDmaPs_CPCn_OFFSET_2 | 0x00000114 | 32 | mixed | 0x00000000 | Channel PC for DMA Channel 2 |
| XDmaPs_CSn_OFFSET_3 | 0x00000118 | 32 | mixed | 0x00000000 | Channel Status DMA Channel 3 |
| XDmaPs_CPCn_OFFSET_3 | 0x0000011C | 32 | mixed | 0x00000000 | Channel PC for DMA Channel 3 |
| XDmaPs_CSn_OFFSET_4 | 0x00000120 | 32 | mixed | 0x00000000 | Channel Status DMA Channel 4 |
| XDmaPs_CPCn_OFFSET_4 | 0x00000124 | 32 | mixed | 0x00000000 | Channel PC for DMA Channel 4 |
| XDmaPs_CSn_OFFSET_5 | 0x00000128 | 32 | mixed | 0x00000000 | Channel Status DMA Channel 5 |
| XDmaPs_CPCn_OFFSET_5 | 0x0000012C | 32 | mixed | 0x00000000 | Channel PC for DMA Channel 5 |
| XDmaPs_CSn_OFFSET_6 | 0x00000130 | 32 | mixed | 0x00000000 | Channel Status DMA Channel 6 |
| XDmaPs_CPCn_OFFSET_6 | 0x00000134 | 32 | mixed | 0x00000000 | Channel PC for DMA Channel 6 |
| XDmaPs_CSn_OFFSET_7 | 0x00000138 | 32 | mixed | 0x00000000 | Channel Status DMA Channel 7 |
| XDmaPs_CPCn_OFFSET_7 | 0x0000013C | 32 | mixed | 0x00000000 | Channel PC for DMA Channel 7 |
| XDMAPS_SA_0_OFFSET | 0x00000400 | 32 | mixed | 0x00000000 | Source Address DMA Channel 0 |
| XDMAPS_DA_0_OFFSET | 0x00000404 | 32 | mixed | 0x00000000 | Destination Addr DMA Channel 0 |
| XDMAPS_CC_0_OFFSET | 0x00000408 | 32 | mixed | dmac0_ns: 0x00000000 dmac0_s: 0x00800200 | Channel Control DMA Channel 0 |
| XDMAPS_LC0_0_OFFSET | 0x0000040C | 32 | mixed | 0x00000000 | Loop Counter 0 DMA Channel 0 |
| XDMAPS_LC1_0_OFFSET | 0x00000410 | 32 | mixed | 0x00000000 | Loop Counter 1 DMA Channel 0 |
| XDmaPs_SA_n_OFFSET_1 | 0x00000420 | 32 | mixed | 0x00000000 | Source address DMA Channel 1 |
| XDmaPs_DA_n_OFFSET_1 | 0x00000424 | 32 | mixed | 0x00000000 | Destination Addr DMA Channel 1 |
| XDmaPs_CC_n_OFFSET_1 | 0x00000428 | 32 | mixed | dmac0_ns: 0x00000000 dmac0_s: 0x00800200 | Channel Control DMA Channel 1 |
| XDmaPs_LC0_n_OFFSET_1 | 0x0000042C | 32 | mixed | 0x00000000 | Loop Counter 0 DMA Channel 1 |

| Register Name | Address | Width | Type | Reset Value | Description |
|---------------------------------------|------------|-------|-------|---|--------------------------------|
| XDmaPs_LC1_n_OFFSET_1 | 0x00000430 | 32 | mixed | 0x00000000 | Loop Counter 1 DMA Channel 1 |
| XDmaPs_SA_n_OFFSET_2 | 0x00000440 | 32 | mixed | 0x00000000 | Source Address DMA Channel 2 |
| XDmaPs_DA_n_OFFSET_2 | 0x00000444 | 32 | mixed | 0x00000000 | Destination Addr DMA Channel 2 |
| XDmaPs_CC_n_OFFSET_2 | 0x00000448 | 32 | mixed | dmac0_ns: 0x00000000 dmac0_s: 0x00800200 | Channel Control DMA Channel 2 |
| XDmaPs_LC0_n_OFFSET_2 | 0x0000044C | 32 | mixed | 0x00000000 | Loop Counter 0 DMA Channel 2 |
| XDmaPs_LC1_n_OFFSET_2 | 0x00000450 | 32 | mixed | 0x00000000 | Loop Counter 1 DMA Channel 2 |
| XDmaPs_SA_n_OFFSET_3 | 0x00000460 | 32 | mixed | 0x00000000 | Source Address DMA Channel 3 |
| XDmaPs_DA_n_OFFSET_3 | 0x00000464 | 32 | mixed | 0x00000000 | Destination Addr DMA Channel 3 |
| XDmaPs_CC_n_OFFSET_3 | 0x00000468 | 32 | mixed | dmac0_ns: 0x00000000 dmac0_s: 0x00800200 | Channel Control DMA Channel 3 |
| XDmaPs_LC0_n_OFFSET_3 | 0x0000046C | 32 | mixed | 0x00000000 | Loop Counter 0 DMA Channel 3 |
| XDmaPs_LC1_n_OFFSET_3 | 0x00000470 | 32 | mixed | 0x00000000 | Loop Counter 1 DMA Channel 3 |
| XDmaPs_SA_n_OFFSET_4 | 0x00000480 | 32 | mixed | 0x00000000 | Source Address DMA Channel 4 |
| XDmaPs_DA_n_OFFSET_4 | 0x00000484 | 32 | mixed | 0x00000000 | Destination Addr DMA Channel 4 |
| XDmaPs_CC_n_OFFSET_4 | 0x00000488 | 32 | mixed | dmac0_ns: 0x00000000 dmac0_s: 0x00800200 | Channel Control DMA Channel 4 |
| XDmaPs_LC0_n_OFFSET_4 | 0x0000048C | 32 | mixed | 0x00000000 | Loop Counter 0 DMA Channel 4 |
| XDmaPs_LC1_n_OFFSET_4 | 0x00000490 | 32 | mixed | 0x00000000 | Loop Counter 1 DMA Channel 4 |
| XDmaPs_SA_n_OFFSET_5 | 0x000004A0 | 32 | mixed | 0x00000000 | Source Address DMA Channel 5 |
| XDmaPs_DA_n_OFFSET_5 | 0x000004A4 | 32 | mixed | 0x00000000 | Destination Addr DMA Channel 5 |
| XDmaPs_CC_n_OFFSET_5 | 0x000004A8 | 32 | mixed | dmac0_ns: 0x00000000 dmac0_s: 0x00800200 | Channel Control DMA Channel 5 |

| Register Name | Address | Width | Type | Reset Value | Description |
|---|------------|-------|-------|---|--|
| XDmaPs_LC0_n_OFFSET_5 | 0x000004AC | 32 | mixed | 0x00000000 | Loop Counter 0 DMA Channel 5 |
| XDmaPs_LC1_n_OFFSET_5 | 0x000004B0 | 32 | mixed | 0x00000000 | Loop Counter 1 DMA Channel 5 |
| XDmaPs_SA_n_OFFSET_6 | 0x000004C0 | 32 | mixed | 0x00000000 | Source Address DMA Channel 6 |
| XDmaPs_DA_n_OFFSET_6 | 0x000004C4 | 32 | mixed | 0x00000000 | Destination Addr DMA Channel 6 |
| XDmaPs_CC_n_OFFSET_6 | 0x000004C8 | 32 | mixed | dmac0_ns: 0x00000000 dmac0_s: 0x00800200 | Channel Control DMA Channel 6 |
| XDmaPs_LC0_n_OFFSET_6 | 0x000004CC | 32 | mixed | 0x00000000 | Loop Counter 0 DMA Channel 6 |
| XDmaPs_LC1_n_OFFSET_6 | 0x000004D0 | 32 | mixed | 0x00000000 | Loop Counter 1 DMA Channel 6 |
| XDmaPs_SA_n_OFFSET_7 | 0x000004E0 | 32 | mixed | 0x00000000 | Source Address DMA Channel 7 |
| XDmaPs_DA_n_OFFSET_7 | 0x000004E4 | 32 | mixed | 0x00000000 | Destination Addr DMA Channel 7 |
| XDmaPs_CC_n_OFFSET_7 | 0x000004E8 | 32 | mixed | dmac0_ns: 0x00000000 dmac0_s: 0x00800200 | Channel Control DMA Channel 7 |
| XDmaPs_LC0_n_OFFSET_7 | 0x000004EC | 32 | mixed | 0x00000000 | Loop Counter 0 DMA Channel 7 |
| XDmaPs_LC1_n_OFFSET_7 | 0x000004F0 | 32 | mixed | 0x00000000 | Loop Counter 1 DMA Channel 7 |
| XDMAPS_DBGSTATUS_OFFSET | 0x00000D00 | 32 | mixed | 0x00000000 | DMA Manager Execution Status |
| XDMAPS_DBGCMD_OFFSET | 0x00000D04 | 32 | mixed | 0x00000000 | DMA Manager Instr. Command |
| XDMAPS_DBGINST0_OFFSET | 0x00000D08 | 32 | mixed | 0x00000000 | DMA Manager Instruction Part A |
| XDMAPS_DBGINST1_OFFSET | 0x00000D0C | 32 | mixed | 0x00000000 | DMA Manager Instruction Part B |
| XDMAPS_CR0_OFFSET | 0x00000E00 | 32 | mixed | dmac0_ns: 0x00000000 dmac0_s: 0x001E3071 | Config. 0: Events, Peripheral Interfaces, PC, Mode |
| XDMAPS_CR1_OFFSET | 0x00000E04 | 32 | mixed | dmac0_ns: 0x00000000 dmac0_s: 0x00000074 | Config. 1: Instruction Cache |
| XDMAPS_CR2_OFFSET | 0x00000E08 | 32 | mixed | 0x00000000 | Config. 2: DMA Mgr Boot Addr |

| Register Name | Address | Width | Type | Reset Value | Description |
|---|------------|-------|-------|---|---|
| XDMAPS_CR3_OFFSET | 0x00000E0C | 32 | mixed | 0x00000000 | Config. 3: Security state of IRQs |
| XDMAPS_CR4_OFFSET | 0x00000E10 | 32 | mixed | 0x00000000 | Config 4, Security of Periph Interfaces |
| XDMAPS_CRDN_OFFSET | 0x00000E14 | 32 | mixed | dmac0_ns: 0x00000000 dmac0_s: 0x07FF7F73 | DMA configuration |
| WD | 0x00000E80 | 32 | mixed | 0x00000000 | Watchdog Timer |
| XDMAPS_PERIPH_ID_0_OFFSET | 0x00000FE0 | 32 | mixed | dmac0_ns: 0x00000000 dmac0_s: 0x00000030 | Peripheral Identification register 0 |
| XDMAPS_PERIPH_ID_1_OFFSET | 0x00000FE4 | 32 | mixed | dmac0_ns: 0x00000000 dmac0_s: 0x00000013 | Peripheral Identification register 1 |
| XDMAPS_PERIPH_ID_2_OFFSET | 0x00000FE8 | 32 | mixed | dmac0_ns: 0x00000000 dmac0_s: 0x00000024 | Peripheral Identification register 2 |
| XDMAPS_PERIPH_ID_3_OFFSET | 0x00000FEC | 32 | mixed | 0x00000000 | Peripheral Identification register 3 |
| XDMAPS_PCELL_ID_0_OFFSET | 0x00000FF0 | 32 | mixed | dmac0_ns: 0x00000000 dmac0_s: 0x0000000D | Component Identification register 0 |
| XDMAPS_PCELL_ID_1_OFFSET | 0x00000FF4 | 32 | mixed | dmac0_ns: 0x00000000 dmac0_s: 0x000000F0 | Component Identification register 1 |
| XDMAPS_PCELL_ID_2_OFFSET | 0x00000FF8 | 32 | mixed | dmac0_ns: 0x00000000 dmac0_s: 0x00000005 | Component Identification register 2 |
| XDMAPS_PCELL_ID_3_OFFSET | 0x00000FFC | 32 | mixed | dmac0_ns: 0x00000000 dmac0_s: 0x000000B1 | Component Identification register 3 |

Register ([dmac](#)) XDMAPS_DS_OFFSET

Name XDMAPS_DS_OFFSET
 Software Name DS
 Relative Address 0x00000000

Absolute Address dmac0_ns: 0xF8004000
 dmac0_s: 0xF8003000

Width 32 bits

Access Type mixed

Reset Value 0x00000000

Description DMA Manager Status

Register XDMAPS_DS_OFFSET Details

| Field Name | Bits | Type | Reset Value | Description |
|--------------|-------|---------------------------|-------------|---|
| reserved | 31:10 | rud | 0x0 | Reserved, read undefined |
| DNS | 9 | sro,ns sraz,n snsro | 0x0 | Provides the security status of the DMA manager thread: 0: Secure state 1: Non-secure state |
| Wakeup_event | 8:4 | sro,ns sraz,n snsro | 0x0 | When the DMA manager executes a DMAWFE instruction, it is waiting for one of the following events to occur from any of the DMA channel threads: 0 0000: event[0] 0 0001: event[1] ... 0 1111: event[15] 1 xxxx: reserved |
| DMA_status | 3:0 | sro,ns sraz,n snsro | 0x0 | The current operating state of the DMA manager: 0000: Stopped 0001: Executing 0010: Cache miss 0011: Updating PC 0100: Waiting for event 0101 to 1110: reserved 1111: Faulting. |

Register ([dmac](#)) XDMAPS_DPC_OFFSET

Name XDMAPS_DPC_OFFSET

Software Name DPC

Relative Address 0x00000004

Absolute Address dmac0_ns: 0xF8004004
 dmac0_s: 0xF8003004

Width 32 bits

Access Type mixed

Reset Value 0x00000000

Description DMA Program Counter

Register XDMAPS_DPC_OFFSET Details

| Field Name | Bits | Type | Reset Value | Description |
|------------|------|---------------------------|-------------|--|
| pc_mgr | 31:0 | sro,ns sraz,n snsro | 0x0 | Program counter for the DMA manager thread |

Register ([dmac](#)) XDMAPS_INTEN_OFFSET

Name XDMAPS_INTEN_OFFSET
 Software Name INTEN
 Relative Address 0x00000020
 Absolute Address dmac0_ns: 0xF8004020
 dmac0_s: 0xF8003020
 Width 32 bits
 Access Type mixed
 Reset Value 0x00000000
 Description DMASEV Instruction Response Control

Register XDMAPS_INTEN_OFFSET Details

| Field Name | Bits | Type | Reset Value | Description |
|------------------|------|---------------------------|-------------|--|
| event_irq_select | 31:0 | srw,ns sraz,n snsrw | 0x0 | Control the respond of a DMA channel thread when it executes a DMASEV instruction. The channel thread will either signal the same DMASEV instruction to the other threads, or assert its interrupt signal. Bits [7:0] correspond to channels [7:0]. 0: The channel tread signals a DMASEV to the other threads (this typically selected when interrupts are not used) 1: Assert the channel's interrupt signal to the PS interrupt controller. Reserved |

Register ([dmac](#)) XDMAPS_ES_OFFSET

Name XDMAPS_ES_OFFSET
 Software Name ES
 Relative Address 0x00000024

Absolute Address dmac0_ns: 0xF8004024
 dmac0_s: 0xF8003024

Width 32 bits

Access Type mixed

Reset Value 0x00000000

Description Event Interrupt Raw Status

Register XDMAPS_ES_OFFSET Details

| Field Name | Bits | Type | Reset Value | Description |
|---------------|------|---------------------------|-------------|--|
| DMASEV_active | 31:0 | sro,ns sraz,n snsro | 0x0 | Raw status of the event or interrupt state. There are sixteen possible event settings [15:0] and eight possible interrupts [7:0]: 0: Inactive 1: Active Note: When the DMAC executes a DMASEV N instruction to send event N, the INTEN Register controls whether the DMAC: signals an interrupt using the appropriate irq sends the event to all of the threads. Reserved |

Register ([dmac](#)) XDMAPS_INTSTATUS_OFFSET

Name XDMAPS_INTSTATUS_OFFSET

Software Name INTSTATUS

Relative Address 0x00000028

Absolute Address dmac0_ns: 0xF8004028
 dmac0_s: 0xF8003028

Width 32 bits

Access Type mixed

Reset Value 0x00000000

Description Interrupt Status

Register XDMAPS_INTSTATUS_OFFSET Details

| Field Name | Bits | Type | Reset Value | Description |
|------------|------|---------------------------|-------------|--|
| irq_status | 31:0 | sro,ns sraz,n snsro | 0x0 | Interrupt signal state for DMA channel [7:0]: 0: inactive (IRQ signals is Low). 1: active (IRQ signals is High). Reserved |

Register ([dmac](#)) XDMAPS_INTCLR_OFFSET

| | |
|------------------|---|
| Name | XDMAPS_INTCLR_OFFSET |
| Software Name | INTCLR |
| Relative Address | 0x0000002C |
| Absolute Address | dmac0_ns: 0xF800402C dmac0_s: 0xF800302C |
| Width | 32 bits |
| Access Type | mixed |
| Reset Value | 0x00000000 |
| Description | Interrupt Clear |

Register XDMAPS_INTCLR_OFFSET Details

| Field Name | Bits | Type | Reset Value | Description |
|------------|------|-------------------------------|-------------|---|
| irq_clr | 31:0 | swo,n ssraz, nsnsw o | 0x0 | Clear interrupt(s) for DMA channel [7:0]: 0: no affect 1: clear the interrupt Reserved |

Register ([dmac](#)) XDMAPS_FSM_OFFSET

| | |
|------------------|---|
| Name | XDMAPS_FSM_OFFSET |
| Software Name | FSM |
| Relative Address | 0x00000030 |
| Absolute Address | dmac0_ns: 0xF8004030 dmac0_s: 0xF8003030 |
| Width | 32 bits |
| Access Type | mixed |
| Reset Value | 0x00000000 |
| Description | Fault Status DMA Manager |

Register XDMAPS_FSM_OFFSET Details

| Field Name | Bits | Type | Reset Value | Description |
|------------|------|---------------------------|-------------|--|
| reserved | 31:1 | rud | 0x0 | reserved, read undefined |
| fs_mgr | 0 | sro,ns sraz,n snsro | 0x0 | Provides the fault status of the DMA manager: 0: Not in the Faulting state 1: Faulting state |

Register ([dmac](#)) XDMAPS_FSC_OFFSET

| | |
|------------------|---|
| Name | XDMAPS_FSC_OFFSET |
| Software Name | FSC |
| Relative Address | 0x00000034 |
| Absolute Address | dmac0_ns: 0xF8004034 dmac0_s: 0xF8003034 |
| Width | 32 bits |
| Access Type | mixed |
| Reset Value | 0x00000000 |
| Description | Fault Status DMA Channel |

Register XDMAPS_FSC_OFFSET Details

| Field Name | Bits | Type | Reset Value | Description |
|--------------|------|---------------------------|-------------|---|
| reserved | 31:8 | rud | 0x0 | reserved, read undefined |
| fault_status | 7:0 | sro,ns sraz,n snsro | 0x0 | Each bit provides the fault status of the corresponding DMA channel, Bits [7:0]: 0: No fault present 1: Fault or Fault completing state |

Register ([dmac](#)) XDMAPS_FTM_OFFSET

| | |
|------------------|---|
| Name | XDMAPS_FTM_OFFSET |
| Software Name | FTM |
| Relative Address | 0x00000038 |
| Absolute Address | dmac0_ns: 0xF8004038 dmac0_s: 0xF8003038 |
| Width | 32 bits |
| Access Type | mixed |
| Reset Value | 0x00000000 |
| Description | Fault Type DMA Manager |

Register XDMAPS_FTM_OFFSET Details

| Field Name | Bits | Type | Reset Value | Description |
|-----------------|-------|---------------------------|-------------|--|
| reserved | 31 | rud | 0x0 | read undefined |
| dbg_instr | 30 | sro,ns sraz,n snsro | 0x0 | If the DMA manager aborts, this bit indicates whether the erroneous instruction was read from the system memory or from the debug interface: 0: system memory 1: debug interface |
| reserved | 29:17 | rud | 0x0 | read undefined |
| instr_fetch_err | 16 | sro,ns sraz,n snsro | 0x0 | Indicates the AXI response that the DMAC receives on the RRESP bus, after the DMA manager performs an instruction fetch: 0: OKAY response 1: EXOKAY, SLVERR, or DECERR response |
| reserved | 15:6 | rud | 0x0 | read undefined |
| mgr_evnt_err | 5 | sro,ns sraz,n snsro | 0x0 | Indicates whether the DMA manager was attempting to execute DMAWFE or DMASEV with inappropriate security permissions: 0: the DMA manager has appropriate security to execute DMAWFE or DMASEV 1: a DMA manager thread in the Non-secure state attempted to execute either: DMAWFE to wait for a secure event H18DMASEV to create a secure event or secure interrupt. |
| dmago_err | 4 | sro,ns sraz,n snsro | 0x0 | Indicates whether the DMA manager was attempting to execute DMAGO with inappropriate security permissions: 0: appropriate security to execute DMAGO 1: Non-secure state attempted to execute DMAGO to create a DMA channel thread operating in the Secure state |
| reserved | 3:2 | rud | 0x0 | read undefined |
| operand_invalid | 1 | sro,ns sraz,n snsro | 0x0 | Indicates whether the DMA manager was attempting to execute an instruction operand that was not valid for the configuration of the DMAC: 0: valid operand 1: invalid operand |
| undef_instr | 0 | sro,ns sraz,n snsro | 0x0 | Indicates whether the DMA manager was attempting to execute an undefined instruction: 0: defined instruction 1: undefined instruction. |

Register ([dmac](#)) XDMAPS_FTC0_OFFSET

| | |
|------------------|---|
| Name | XDMAPS_FTC0_OFFSET |
| Software Name | FTC0 |
| Relative Address | 0x00000040 |
| Absolute Address | dmac0_ns: 0xF8004040 dmac0_s: 0xF8003040 |
| Width | 32 bits |
| Access Type | mixed |
| Reset Value | 0x00000000 |
| Description | Default Type DMA Channel 0 |

Register XDMAPS_FTC0_OFFSET Details

| Field Name | Bits | Type | Reset Value | Description |
|----------------|-------|---------------------------|-------------|--|
| lockup_err | 31 | sro,ns sraz,n snsro | 0x0 | Indicates whether the DMA channel thread has locked-up because of resource starvation: 0: DMA channel has adequate resources 1: DMA channel has locked-up because of insufficient resources. This fault is an imprecise abort. |
| dbg_instr | 30 | sro,ns sraz,n snsro | 0x0 | If the DMA channel aborts, this bit indicates whether the erroneous instruction was read from the system memory or from the debug interface: 0: system memory 1: debug interface. |
| reserved | 29:19 | sro,nss raz,ns nsro | 0x0 | read undefined |
| data_read_err | 18 | sro,ns sraz,n snsro | 0x0 | Indicates the AXI response that the DMAC receives on the RRESP bus, after the DMA channel thread performs a data read: 0: OKAY response 1: EXOKAY, SLVERR, or DECERR response. This fault is an imprecise abort. |
| data_write_err | 17 | sro,ns sraz,n snsro | 0x0 | Indicates the AXI response that the DMAC receives on the BRESP bus, after the DMA channel thread performs a data write: 0: OKAY response 1: EXOKAY, SLVERR, or DECERR response. This fault is an imprecise abort. |

| Field Name | Bits | Type | Reset Value | Description |
|---------------------|-------|---------------------------|-------------|--|
| instr_fetch_err | 16 | sro,ns sraz,n snsro | 0x0 | Indicates the AXI response that the DMAC receives on the RRESP bus after the DMA channel thread performs an instruction fetch: 0: OKAY response 1: EXOKAY, SLVERR, or DECERR response. This fault is a precise abort. |
| reserved | 15:14 | sro,nss raz,ns nsro | 0x0 | read undefined |
| st_data_unavailable | 13 | sro,ns sraz,n snsro | 0x0 | Indicates whether the MFIFO did not contain the data to enable the DMAC to perform the DMAST: 0: MFIFO contains all the data to enable the DMAST to complete 1: previous DMALDs have not put enough data in the MFIFO to enable the DMAST to complete. This fault is a precise abort. |
| mfifo_err | 12 | sro,ns sraz,n snsro | 0x0 | Indicates whether the MFIFO prevented the DMA channel thread from executing DMALD or DMAST: DMALD: 0: MFIFO contains sufficient space 1: MFIFO is too small to hold the data that DMALD requires. DMAST: 0: MFIFO contains sufficient data 1: MFIFO is too small to store the data to enable DMAST to complete. This fault is an imprecise abort. |
| reserved | 11:8 | sro,nss raz,ns nsro | 0x0 | read undefined |
| ch_rdwr_err | 7 | sro,ns sraz,n snsro | 0x0 | Indicates whether a DMA channel thread, in the Non-secure state, attempts to program the CCR registers to perform a secure read or secure write: 0: a DMA channel thread in the Non-secure state is not violating the security permissions 1: a DMA channel thread in the Non-secure state attempted to perform a secure read or secure write. This fault is a precise abort. |
| ch_periph_err | 6 | sro,ns sraz,n snsro | 0x0 | Indicates whether a DMA channel thread, in the Non-secure state, attempts to execute DMAWFP, DMALDP, DMASTP, or DMAFLUSHP with inappropriate security permissions: 0: a DMA channel thread in the Non-secure state is not violating the security permissions 1: a DMA channel thread in the Non-secure state attempted to execute either: a) DMAWFP to wait for a secure peripheral, b) DMALDP or DMASTP to notify a secure peripheral, or c) DMAFLUSHP to flush a secure peripheral. This fault is a precise abort. |

| Field Name | Bits | Type | Reset Value | Description |
|-----------------|------|---------------------------|-------------|--|
| ch_evnt_err | 5 | sro,ns sraz,n snsro | 0x0 | Indicates whether the DMA channel thread attempts to execute DMAWFE or DMASEV with inappropriate security permissions: 0: a DMA channel thread in the Non-secure state is not violating the security permissions 1: a DMA channel thread in the Non-secure state attempted to execute either: a) DMAWFE to wait for a secure event, or b) DMASEV to create a secure event or secure interrupt. This fault is a precise abort. |
| reserved | 4:2 | sro,nss raz,ns nsro | 0x0 | read undefined |
| operand_invalid | 1 | sro,ns sraz,n snsro | 0x0 | Indicates whether the DMA channel thread was attempting to execute an instruction operand that was not valid for the configuration of the DMAC: 0: valid operand 1: invalid operand. This fault is a precise abort. |
| undef_instr | 0 | sro,ns sraz,n snsro | 0x0 | Indicates whether the DMA channel thread was attempting to execute an undefined instruction: 0: defined instruction 1: undefined instruction. This fault is a precise abort. |

Register ([dmac](#)) XDmaPs_FTCn_OFFSET_1

| | |
|------------------|---|
| Name | XDmaPs_FTCn_OFFSET_1 |
| Relative Address | 0x00000044 |
| Absolute Address | dmac0_ns: 0xF8004044 dmac0_s: 0xF8003044 |
| Width | 32 bits |
| Access Type | mixed |
| Reset Value | 0x00000000 |
| Description | Default Type DMA Channel 1 |

Register XDmaPs_FTCn_OFFSET_1 Details

| Field Name | Bits | Type | Reset Value | Description |
|---------------------|-------|---------------------------|-------------|---|
| lockup_err | 31 | sro,ns sraz,n snsro | 0x0 | Indicates whether the DMA channel thread has locked-up because of resource starvation: 0: DMA channel has adequate resources 1: DMA channel has locked-up because of insufficient resources. This fault is an imprecise abort. |
| dbg_instr | 30 | sro,ns sraz,n snsro | 0x0 | If the DMA channel aborts, this bit indicates whether the erroneous instruction was read from the system memory or from the debug interface: 0: system memory 1: debug interface. |
| reserved | 29:19 | sro,nss raz,ns nsro | 0x0 | read undefined |
| data_read_err | 18 | sro,ns sraz,n snsro | 0x0 | Indicates the AXI response that the DMAC receives on the RRESP bus, after the DMA channel thread performs a data read: 0: OKAY response 1: EXOKAY, SLVERR, or DECERR response. This fault is an imprecise abort. |
| data_write_err | 17 | sro,ns sraz,n snsro | 0x0 | Indicates the AXI response that the DMAC receives on the BRESP bus, after the DMA channel thread performs a data write: 0: OKAY response 1: EXOKAY, SLVERR, or DECERR response. This fault is an imprecise abort. |
| instr_fetch_err | 16 | sro,ns sraz,n snsro | 0x0 | Indicates the AXI response that the DMAC receives on the RRESP bus after the DMA channel thread performs an instruction fetch: 0: OKAY response 1: EXOKAY, SLVERR, or DECERR response. This fault is a precise abort. |
| reserved | 15:14 | sro,nss raz,ns nsro | 0x0 | read undefined |
| st_data_unavailable | 13 | sro,ns sraz,n snsro | 0x0 | Indicates whether the MFIFO did not contain the data to enable the DMAC to perform the DMAST: 0: MFIFO contains all the data to enable the DMAST to complete 1: previous DMALDs have not put enough data in the MFIFO to enable the DMAST to complete. This fault is a precise abort. |

| Field Name | Bits | Type | Reset Value | Description |
|---------------|------|---------------------------|-------------|--|
| mfifo_err | 12 | sro,ns sraz,n snsro | 0x0 | Indicates whether the MFIFO prevented the DMA channel thread from executing DMALD or DMAST: DMALD: 0: MFIFO contains sufficient space 1: MFIFO is too small to hold the data that DMALD requires. DMAST: 0: MFIFO contains sufficient data 1: MFIFO is too small to store the data to enable DMAST to complete. This fault is an imprecise abort. |
| reserved | 11:8 | sro,nss raz,ns nsro | 0x0 | read undefined |
| ch_rdwr_err | 7 | sro,ns sraz,n snsro | 0x0 | Indicates whether a DMA channel thread, in the Non-secure state, attempts to program the CCR registers to perform a secure read or secure write: 0: a DMA channel thread in the Non-secure state is not violating the security permissions 1: a DMA channel thread in the Non-secure state attempted to perform a secure read or secure write. This fault is a precise abort. |
| ch_periph_err | 6 | sro,ns sraz,n snsro | 0x0 | Indicates whether a DMA channel thread, in the Non-secure state, attempts to execute DMAWFP, DMALDP, DMASTP, or DMAFLUSHP with inappropriate security permissions: 0: a DMA channel thread in the Non-secure state is not violating the security permissions 1: a DMA channel thread in the Non-secure state attempted to execute either: a) DMAWFP to wait for a secure peripheral, b) DMALDP or DMASTP to notify a secure peripheral, or c) DMAFLUSHP to flush a secure peripheral. This fault is a precise abort. |
| ch_evnt_err | 5 | sro,ns sraz,n snsro | 0x0 | Indicates whether the DMA channel thread attempts to execute DMAWFE or DMASEV with inappropriate security permissions: 0: a DMA channel thread in the Non-secure state is not violating the security permissions 1: a DMA channel thread in the Non-secure state attempted to execute either: a) DMAWFE to wait for a secure event, or b) DMASEV to create a secure event or secure interrupt. This fault is a precise abort. |
| reserved | 4:2 | sro,nss raz,ns nsro | 0x0 | read undefined |

| Field Name | Bits | Type | Reset Value | Description |
|-----------------|------|---------------------------|-------------|--|
| operand_invalid | 1 | sro,ns sraz,n snsro | 0x0 | Indicates whether the DMA channel thread was attempting to execute an instruction operand that was not valid for the configuration of the DMAC: 0: valid operand 1: invalid operand. This fault is a precise abort. |
| undef_instr | 0 | sro,ns sraz,n snsro | 0x0 | Indicates whether the DMA channel thread was attempting to execute an undefined instruction: 0: defined instruction 1: undefined instruction. This fault is a precise abort. |

Register ([dmac](#)) XDmaPs_FTCn_OFFSET_2

| | |
|------------------|---|
| Name | XDmaPs_FTCn_OFFSET_2 |
| Relative Address | 0x00000048 |
| Absolute Address | dmac0_ns: 0xF8004048 dmac0_s: 0xF8003048 |
| Width | 32 bits |
| Access Type | mixed |
| Reset Value | 0x00000000 |
| Description | Default Type DMA Channel 2 |

Register XDmaPs_FTCn_OFFSET_2 Details

| Field Name | Bits | Type | Reset Value | Description |
|------------|-------|---------------------------|-------------|--|
| lockup_err | 31 | sro,ns sraz,n snsro | 0x0 | Indicates whether the DMA channel thread has locked-up because of resource starvation: 0: DMA channel has adequate resources 1: DMA channel has locked-up because of insufficient resources. This fault is an imprecise abort. |
| dbg_instr | 30 | sro,ns sraz,n snsro | 0x0 | If the DMA channel aborts, this bit indicates whether the erroneous instruction was read from the system memory or from the debug interface: 0: system memory 1: debug interface. |
| reserved | 29:19 | sro,nss raz,ns nsro | 0x0 | read undefined |

| Field Name | Bits | Type | Reset Value | Description |
|---------------------|-------|---------------------------|-------------|--|
| data_read_err | 18 | sro,ns sraz,n snsro | 0x0 | Indicates the AXI response that the DMAC receives on the RRESP bus, after the DMA channel thread performs a data read: 0: OKAY response 1: EXOKAY, SLVERR, or DECERR response. This fault is an imprecise abort. |
| data_write_err | 17 | sro,ns sraz,n snsro | 0x0 | Indicates the AXI response that the DMAC receives on the BRESP bus, after the DMA channel thread performs a data write: 0: OKAY response 1: EXOKAY, SLVERR, or DECERR response. This fault is an imprecise abort. |
| instr_fetch_err | 16 | sro,ns sraz,n snsro | 0x0 | Indicates the AXI response that the DMAC receives on the RRESP bus after the DMA channel thread performs an instruction fetch: 0: OKAY response 1: EXOKAY, SLVERR, or DECERR response. This fault is a precise abort. |
| reserved | 15:14 | sro,nss raz,ns nsro | 0x0 | read undefined |
| st_data_unavailable | 13 | sro,ns sraz,n snsro | 0x0 | Indicates whether the MFIFO did not contain the data to enable the DMAC to perform the DMAST: 0: MFIFO contains all the data to enable the DMAST to complete 1: previous DMALDs have not put enough data in the MFIFO to enable the DMAST to complete. This fault is a precise abort. |
| mfifo_err | 12 | sro,ns sraz,n snsro | 0x0 | Indicates whether the MFIFO prevented the DMA channel thread from executing DMALD or DMAST: DMALD: 0: MFIFO contains sufficient space 1: MFIFO is too small to hold the data that DMALD requires. DMAST: 0: MFIFO contains sufficient data 1: MFIFO is too small to store the data to enable DMAST to complete. This fault is an imprecise abort. |
| reserved | 11:8 | sro,nss raz,ns nsro | 0x0 | read undefined |

| Field Name | Bits | Type | Reset Value | Description |
|-----------------|------|---------------------------|-------------|--|
| ch_rdwr_err | 7 | sro,ns sraz,n snsro | 0x0 | Indicates whether a DMA channel thread, in the Non-secure state, attempts to program the CCR registers to perform a secure read or secure write: 0: a DMA channel thread in the Non-secure state is not violating the security permissions 1: a DMA channel thread in the Non-secure state attempted to perform a secure read or secure write. This fault is a precise abort. |
| ch_periph_err | 6 | sro,ns sraz,n snsro | 0x0 | Indicates whether a DMA channel thread, in the Non-secure state, attempts to execute DMAWFP, DMALDP, DMASTP, or DMAFLUSHP with inappropriate security permissions: 0: a DMA channel thread in the Non-secure state is not violating the security permissions 1: a DMA channel thread in the Non-secure state attempted to execute either: a) DMAWFP to wait for a secure peripheral, b) DMALDP or DMASTP to notify a secure peripheral, or c) DMAFLUSHP to flush a secure peripheral. This fault is a precise abort. |
| ch_evnt_err | 5 | sro,ns sraz,n snsro | 0x0 | Indicates whether the DMA channel thread attempts to execute DMAWFE or DMASEV with inappropriate security permissions: 0: a DMA channel thread in the Non-secure state is not violating the security permissions 1: a DMA channel thread in the Non-secure state attempted to execute either: a) DMAWFE to wait for a secure event, or b) DMASEV to create a secure event or secure interrupt. This fault is a precise abort. |
| reserved | 4:2 | sro,nss raz,ns nsro | 0x0 | read undefined |
| operand_invalid | 1 | sro,ns sraz,n snsro | 0x0 | Indicates whether the DMA channel thread was attempting to execute an instruction operand that was not valid for the configuration of the DMAC: 0: valid operand 1: invalid operand. This fault is a precise abort. |
| undef_instr | 0 | sro,ns sraz,n snsro | 0x0 | Indicates whether the DMA channel thread was attempting to execute an undefined instruction: 0: defined instruction 1: undefined instruction. This fault is a precise abort. |

Register ([dmac](#)) XDmaPs_FTCn_OFFSET_3

Name XDmaPs_FTCn_OFFSET_3

Relative Address 0x0000004C
 Absolute Address dmac0_ns: 0xF800404C
 dmac0_s: 0xF800304C
 Width 32 bits
 Access Type mixed
 Reset Value 0x00000000
 Description Default Type DMA Channel 3

Register XDmaPs_FTCn_OFFSET_3 Details

| Field Name | Bits | Type | Reset Value | Description |
|-----------------|-------|---------------------------|-------------|--|
| lockup_err | 31 | sro,ns sraz,n snsro | 0x0 | Indicates whether the DMA channel thread has locked-up because of resource starvation: 0: DMA channel has adequate resources 1: DMA channel has locked-up because of insufficient resources. This fault is an imprecise abort. |
| dbg_instr | 30 | sro,ns sraz,n snsro | 0x0 | If the DMA channel aborts, this bit indicates whether the erroneous instruction was read from the system memory or from the debug interface: 0: system memory 1: debug interface. |
| reserved | 29:19 | sro,nss raz,ns nsro | 0x0 | read undefined |
| data_read_err | 18 | sro,ns sraz,n snsro | 0x0 | Indicates the AXI response that the DMAC receives on the RRESP bus, after the DMA channel thread performs a data read: 0: OKAY response 1: EXOKAY, SLVERR, or DECERR response. This fault is an imprecise abort. |
| data_write_err | 17 | sro,ns sraz,n snsro | 0x0 | Indicates the AXI response that the DMAC receives on the BRESP bus, after the DMA channel thread performs a data write: 0: OKAY response 1: EXOKAY, SLVERR, or DECERR response. This fault is an imprecise abort. |
| instr_fetch_err | 16 | sro,ns sraz,n snsro | 0x0 | Indicates the AXI response that the DMAC receives on the RRESP bus after the DMA channel thread performs an instruction fetch: 0: OKAY response 1: EXOKAY, SLVERR, or DECERR response. This fault is a precise abort. |
| reserved | 15:14 | sro,nss raz,ns nsro | 0x0 | read undefined |

| Field Name | Bits | Type | Reset Value | Description |
|---------------------|------|---------------------------|-------------|--|
| st_data_unavailable | 13 | sro,ns sraz,n snsro | 0x0 | Indicates whether the MFIFO did not contain the data to enable the DMAC to perform the DMAST: 0: MFIFO contains all the data to enable the DMAST to complete 1: previous DMALDs have not put enough data in the MFIFO to enable the DMAST to complete. This fault is a precise abort. |
| mfifo_err | 12 | sro,ns sraz,n snsro | 0x0 | Indicates whether the MFIFO prevented the DMA channel thread from executing DMALD or DMAST: DMALD: 0: MFIFO contains sufficient space 1: MFIFO is too small to hold the data that DMALD requires. DMAST: 0: MFIFO contains sufficient data 1: MFIFO is too small to store the data to enable DMAST to complete. This fault is an imprecise abort. |
| reserved | 11:8 | sro,nss raz,ns nsro | 0x0 | read undefined |
| ch_rdwr_err | 7 | sro,ns sraz,n snsro | 0x0 | Indicates whether a DMA channel thread, in the Non-secure state, attempts to program the CCR registers to perform a secure read or secure write: 0: a DMA channel thread in the Non-secure state is not violating the security permissions 1: a DMA channel thread in the Non-secure state attempted to perform a secure read or secure write. This fault is a precise abort. |
| ch_periph_err | 6 | sro,ns sraz,n snsro | 0x0 | Indicates whether a DMA channel thread, in the Non-secure state, attempts to execute DMAWFP, DMALDP, DMASTP, or DMAFLUSHP with inappropriate security permissions: 0: a DMA channel thread in the Non-secure state is not violating the security permissions 1: a DMA channel thread in the Non-secure state attempted to execute either: a) DMAWFP to wait for a secure peripheral, b) DMALDP or DMASTP to notify a secure peripheral, or c) DMAFLUSHP to flush a secure peripheral. This fault is a precise abort. |

| Field Name | Bits | Type | Reset Value | Description |
|-----------------|------|---------------------------|-------------|--|
| ch_evnt_err | 5 | sro,ns sraz,n snsro | 0x0 | Indicates whether the DMA channel thread attempts to execute DMAWFE or DMASEV with inappropriate security permissions: 0: a DMA channel thread in the Non-secure state is not violating the security permissions 1: a DMA channel thread in the Non-secure state attempted to execute either: a) DMAWFE to wait for a secure event, or b) DMASEV to create a secure event or secure interrupt. This fault is a precise abort. |
| reserved | 4:2 | sro,nss raz,ns nsro | 0x0 | read undefined |
| operand_invalid | 1 | sro,ns sraz,n snsro | 0x0 | Indicates whether the DMA channel thread was attempting to execute an instruction operand that was not valid for the configuration of the DMAC: 0: valid operand 1: invalid operand. This fault is a precise abort. |
| undef_instr | 0 | sro,ns sraz,n snsro | 0x0 | Indicates whether the DMA channel thread was attempting to execute an undefined instruction: 0: defined instruction 1: undefined instruction. This fault is a precise abort. |

Register ([dmac](#)) XDmaPs_FTCn_OFFSET_4

| | |
|------------------|---|
| Name | XDmaPs_FTCn_OFFSET_4 |
| Relative Address | 0x00000050 |
| Absolute Address | dmac0_ns: 0xF8004050 dmac0_s: 0xF8003050 |
| Width | 32 bits |
| Access Type | mixed |
| Reset Value | 0x00000000 |
| Description | Default Type DMA Channel 4 |

Register XDmaPs_FTCn_OFFSET_4 Details

| Field Name | Bits | Type | Reset Value | Description |
|---------------------|-------|---------------------------|-------------|---|
| lockup_err | 31 | sro,ns sraz,n snsro | 0x0 | Indicates whether the DMA channel thread has locked-up because of resource starvation: 0: DMA channel has adequate resources 1: DMA channel has locked-up because of insufficient resources. This fault is an imprecise abort. |
| dbg_instr | 30 | sro,ns sraz,n snsro | 0x0 | If the DMA channel aborts, this bit indicates whether the erroneous instruction was read from the system memory or from the debug interface: 0: system memory 1: debug interface. |
| reserved | 29:19 | sro,nss raz,ns nsro | 0x0 | read undefined |
| data_read_err | 18 | sro,ns sraz,n snsro | 0x0 | Indicates the AXI response that the DMAC receives on the RRESP bus, after the DMA channel thread performs a data read: 0: OKAY response 1: EXOKAY, SLVERR, or DECERR response. This fault is an imprecise abort. |
| data_write_err | 17 | sro,ns sraz,n snsro | 0x0 | Indicates the AXI response that the DMAC receives on the BRESP bus, after the DMA channel thread performs a data write: 0: OKAY response 1: EXOKAY, SLVERR, or DECERR response. This fault is an imprecise abort. |
| instr_fetch_err | 16 | sro,ns sraz,n snsro | 0x0 | Indicates the AXI response that the DMAC receives on the RRESP bus after the DMA channel thread performs an instruction fetch: 0: OKAY response 1: EXOKAY, SLVERR, or DECERR response. This fault is a precise abort. |
| reserved | 15:14 | sro,nss raz,ns nsro | 0x0 | read undefined |
| st_data_unavailable | 13 | sro,ns sraz,n snsro | 0x0 | Indicates whether the MFIFO did not contain the data to enable the DMAC to perform the DMAST: 0: MFIFO contains all the data to enable the DMAST to complete 1: previous DMALDs have not put enough data in the MFIFO to enable the DMAST to complete. This fault is a precise abort. |

| Field Name | Bits | Type | Reset Value | Description |
|---------------|------|---------------------------|-------------|--|
| mfifo_err | 12 | sro,ns sraz,n snsro | 0x0 | Indicates whether the MFIFO prevented the DMA channel thread from executing DMALD or DMAST: DMALD: 0: MFIFO contains sufficient space 1: MFIFO is too small to hold the data that DMALD requires. DMAST: 0: MFIFO contains sufficient data 1: MFIFO is too small to store the data to enable DMAST to complete. This fault is an imprecise abort. |
| reserved | 11:8 | sro,nss raz,ns nsro | 0x0 | read undefined |
| ch_rdwr_err | 7 | sro,ns sraz,n snsro | 0x0 | Indicates whether a DMA channel thread, in the Non-secure state, attempts to program the CCR registers to perform a secure read or secure write: 0: a DMA channel thread in the Non-secure state is not violating the security permissions 1: a DMA channel thread in the Non-secure state attempted to perform a secure read or secure write. This fault is a precise abort. |
| ch_periph_err | 6 | sro,ns sraz,n snsro | 0x0 | Indicates whether a DMA channel thread, in the Non-secure state, attempts to execute DMAWFP, DMALDP, DMASTP, or DMAFLUSHP with inappropriate security permissions: 0: a DMA channel thread in the Non-secure state is not violating the security permissions 1: a DMA channel thread in the Non-secure state attempted to execute either: a) DMAWFP to wait for a secure peripheral, b) DMALDP or DMASTP to notify a secure peripheral, or c) DMAFLUSHP to flush a secure peripheral. This fault is a precise abort. |
| ch_evnt_err | 5 | sro,ns sraz,n snsro | 0x0 | Indicates whether the DMA channel thread attempts to execute DMAWFE or DMASEV with inappropriate security permissions: 0: a DMA channel thread in the Non-secure state is not violating the security permissions 1: a DMA channel thread in the Non-secure state attempted to execute either: a) DMAWFE to wait for a secure event, or b) DMASEV to create a secure event or secure interrupt. This fault is a precise abort. |
| reserved | 4:2 | sro,nss raz,ns nsro | 0x0 | read undefined |

| Field Name | Bits | Type | Reset Value | Description |
|-----------------|------|---------------------------|-------------|--|
| operand_invalid | 1 | sro,ns sraz,n snsro | 0x0 | Indicates whether the DMA channel thread was attempting to execute an instruction operand that was not valid for the configuration of the DMAC: 0: valid operand 1: invalid operand. This fault is a precise abort. |
| undef_instr | 0 | sro,ns sraz,n snsro | 0x0 | Indicates whether the DMA channel thread was attempting to execute an undefined instruction: 0: defined instruction 1: undefined instruction. This fault is a precise abort. |

Register ([dmac](#)) XDmaPs_FTCn_OFFSET_5

| | |
|------------------|---|
| Name | XDmaPs_FTCn_OFFSET_5 |
| Relative Address | 0x00000054 |
| Absolute Address | dmac0_ns: 0xF8004054 dmac0_s: 0xF8003054 |
| Width | 32 bits |
| Access Type | mixed |
| Reset Value | 0x00000000 |
| Description | Default Type DMA Channel 5 |

Register XDmaPs_FTCn_OFFSET_5 Details

| Field Name | Bits | Type | Reset Value | Description |
|------------|-------|---------------------------|-------------|--|
| lockup_err | 31 | sro,ns sraz,n snsro | 0x0 | Indicates whether the DMA channel thread has locked-up because of resource starvation: 0: DMA channel has adequate resources 1: DMA channel has locked-up because of insufficient resources. This fault is an imprecise abort. |
| dbg_instr | 30 | sro,ns sraz,n snsro | 0x0 | If the DMA channel aborts, this bit indicates whether the erroneous instruction was read from the system memory or from the debug interface: 0: system memory 1: debug interface. |
| reserved | 29:19 | sro,nss raz,ns nsro | 0x0 | read undefined |

| Field Name | Bits | Type | Reset Value | Description |
|---------------------|-------|---------------------------|-------------|--|
| data_read_err | 18 | sro,ns sraz,n snsro | 0x0 | Indicates the AXI response that the DMAC receives on the RRESP bus, after the DMA channel thread performs a data read: 0: OKAY response 1: EXOKAY, SLVERR, or DECERR response. This fault is an imprecise abort. |
| data_write_err | 17 | sro,ns sraz,n snsro | 0x0 | Indicates the AXI response that the DMAC receives on the BRESP bus, after the DMA channel thread performs a data write: 0: OKAY response 1: EXOKAY, SLVERR, or DECERR response. This fault is an imprecise abort. |
| instr_fetch_err | 16 | sro,ns sraz,n snsro | 0x0 | Indicates the AXI response that the DMAC receives on the RRESP bus after the DMA channel thread performs an instruction fetch: 0: OKAY response 1: EXOKAY, SLVERR, or DECERR response. This fault is a precise abort. |
| reserved | 15:14 | sro,nss raz,ns nsro | 0x0 | read undefined |
| st_data_unavailable | 13 | sro,ns sraz,n snsro | 0x0 | Indicates whether the MFIFO did not contain the data to enable the DMAC to perform the DMAST: 0: MFIFO contains all the data to enable the DMAST to complete 1: previous DMALDs have not put enough data in the MFIFO to enable the DMAST to complete. This fault is a precise abort. |
| mfifo_err | 12 | sro,ns sraz,n snsro | 0x0 | Indicates whether the MFIFO prevented the DMA channel thread from executing DMALD or DMAST: DMALD: 0: MFIFO contains sufficient space 1: MFIFO is too small to hold the data that DMALD requires. DMAST: 0: MFIFO contains sufficient data 1: MFIFO is too small to store the data to enable DMAST to complete. This fault is an imprecise abort. |
| reserved | 11:8 | sro,nss raz,ns nsro | 0x0 | read undefined |

| Field Name | Bits | Type | Reset Value | Description |
|-----------------|------|---------------------------|-------------|--|
| ch_rdwr_err | 7 | sro,ns sraz,n snsro | 0x0 | Indicates whether a DMA channel thread, in the Non-secure state, attempts to program the CCR registers to perform a secure read or secure write: 0: a DMA channel thread in the Non-secure state is not violating the security permissions 1: a DMA channel thread in the Non-secure state attempted to perform a secure read or secure write. This fault is a precise abort. |
| ch_periph_err | 6 | sro,ns sraz,n snsro | 0x0 | Indicates whether a DMA channel thread, in the Non-secure state, attempts to execute DMAWFP, DMALDP, DMASTP, or DMAFLUSHP with inappropriate security permissions: 0: a DMA channel thread in the Non-secure state is not violating the security permissions 1: a DMA channel thread in the Non-secure state attempted to execute either: a) DMAWFP to wait for a secure peripheral, b) DMALDP or DMASTP to notify a secure peripheral, or c) DMAFLUSHP to flush a secure peripheral. This fault is a precise abort. |
| ch_evnt_err | 5 | sro,ns sraz,n snsro | 0x0 | Indicates whether the DMA channel thread attempts to execute DMAWFE or DMASEV with inappropriate security permissions: 0: a DMA channel thread in the Non-secure state is not violating the security permissions 1: a DMA channel thread in the Non-secure state attempted to execute either: a) DMAWFE to wait for a secure event, or b) DMASEV to create a secure event or secure interrupt. This fault is a precise abort. |
| reserved | 4:2 | sro,nss raz,ns nsro | 0x0 | read undefined |
| operand_invalid | 1 | sro,ns sraz,n snsro | 0x0 | Indicates whether the DMA channel thread was attempting to execute an instruction operand that was not valid for the configuration of the DMAC: 0: valid operand 1: invalid operand. This fault is a precise abort. |
| undef_instr | 0 | sro,ns sraz,n snsro | 0x0 | Indicates whether the DMA channel thread was attempting to execute an undefined instruction: 0: defined instruction 1: undefined instruction. This fault is a precise abort. |

Register ([dmac](#)) XDmaPs_FTCn_OFFSET_6

Name XDmaPs_FTCn_OFFSET_6

Relative Address 0x00000058
 Absolute Address dmac0_ns: 0xF8004058
 dmac0_s: 0xF8003058
 Width 32 bits
 Access Type mixed
 Reset Value 0x00000000
 Description Default Type DMA Channel 6

Register XDmaPs_FTCn_OFFSET_6 Details

| Field Name | Bits | Type | Reset Value | Description |
|-----------------|-------|---------------------------|-------------|--|
| lockup_err | 31 | sro,ns sraz,n snsro | 0x0 | Indicates whether the DMA channel thread has locked-up because of resource starvation: 0: DMA channel has adequate resources 1: DMA channel has locked-up because of insufficient resources. This fault is an imprecise abort. |
| dbg_instr | 30 | sro,ns sraz,n snsro | 0x0 | If the DMA channel aborts, this bit indicates whether the erroneous instruction was read from the system memory or from the debug interface: 0: system memory 1: debug interface. |
| reserved | 29:19 | sro,nss raz,ns nsro | 0x0 | read undefined |
| data_read_err | 18 | sro,ns sraz,n snsro | 0x0 | Indicates the AXI response that the DMAC receives on the RRESP bus, after the DMA channel thread performs a data read: 0: OKAY response 1: EXOKAY, SLVERR, or DECERR response. This fault is an imprecise abort. |
| data_write_err | 17 | sro,ns sraz,n snsro | 0x0 | Indicates the AXI response that the DMAC receives on the BRESP bus, after the DMA channel thread performs a data write: 0: OKAY response 1: EXOKAY, SLVERR, or DECERR response. This fault is an imprecise abort. |
| instr_fetch_err | 16 | sro,ns sraz,n snsro | 0x0 | Indicates the AXI response that the DMAC receives on the RRESP bus after the DMA channel thread performs an instruction fetch: 0: OKAY response 1: EXOKAY, SLVERR, or DECERR response. This fault is a precise abort. |
| reserved | 15:14 | sro,nss raz,ns nsro | 0x0 | read undefined |

| Field Name | Bits | Type | Reset Value | Description |
|---------------------|------|---------------------------|-------------|--|
| st_data_unavailable | 13 | sro,ns sraz,n snsro | 0x0 | Indicates whether the MFIFO did not contain the data to enable the DMAC to perform the DMAST: 0: MFIFO contains all the data to enable the DMAST to complete 1: previous DMALDs have not put enough data in the MFIFO to enable the DMAST to complete. This fault is a precise abort. |
| mfifo_err | 12 | sro,ns sraz,n snsro | 0x0 | Indicates whether the MFIFO prevented the DMA channel thread from executing DMALD or DMAST: DMALD: 0: MFIFO contains sufficient space 1: MFIFO is too small to hold the data that DMALD requires. DMAST: 0: MFIFO contains sufficient data 1: MFIFO is too small to store the data to enable DMAST to complete. This fault is an imprecise abort. |
| reserved | 11:8 | sro,nss raz,ns nsro | 0x0 | read undefined |
| ch_rdwr_err | 7 | sro,ns sraz,n snsro | 0x0 | Indicates whether a DMA channel thread, in the Non-secure state, attempts to program the CCR registers to perform a secure read or secure write: 0: a DMA channel thread in the Non-secure state is not violating the security permissions 1: a DMA channel thread in the Non-secure state attempted to perform a secure read or secure write. This fault is a precise abort. |
| ch_periph_err | 6 | sro,ns sraz,n snsro | 0x0 | Indicates whether a DMA channel thread, in the Non-secure state, attempts to execute DMAWFP, DMALDP, DMASTP, or DMAFLUSHP with inappropriate security permissions: 0: a DMA channel thread in the Non-secure state is not violating the security permissions 1: a DMA channel thread in the Non-secure state attempted to execute either: a) DMAWFP to wait for a secure peripheral, b) DMALDP or DMASTP to notify a secure peripheral, or c) DMAFLUSHP to flush a secure peripheral. This fault is a precise abort. |

| Field Name | Bits | Type | Reset Value | Description |
|-----------------|------|---------------------------|-------------|--|
| ch_evnt_err | 5 | sro,ns sraz,n snsro | 0x0 | Indicates whether the DMA channel thread attempts to execute DMAWFE or DMASEV with inappropriate security permissions: 0: a DMA channel thread in the Non-secure state is not violating the security permissions 1: a DMA channel thread in the Non-secure state attempted to execute either: a) DMAWFE to wait for a secure event, or b) DMASEV to create a secure event or secure interrupt. This fault is a precise abort. |
| reserved | 4:2 | sro,nss raz,ns nsro | 0x0 | read undefined |
| operand_invalid | 1 | sro,ns sraz,n snsro | 0x0 | Indicates whether the DMA channel thread was attempting to execute an instruction operand that was not valid for the configuration of the DMAC: 0: valid operand 1: invalid operand. This fault is a precise abort. |
| undef_instr | 0 | sro,ns sraz,n snsro | 0x0 | Indicates whether the DMA channel thread was attempting to execute an undefined instruction: 0: defined instruction 1: undefined instruction. This fault is a precise abort. |

Register ([dmac](#)) XDmaPs_FTCn_OFFSET_7

| | |
|------------------|---|
| Name | XDmaPs_FTCn_OFFSET_7 |
| Relative Address | 0x0000005C |
| Absolute Address | dmac0_ns: 0xF800405C dmac0_s: 0xF800305C |
| Width | 32 bits |
| Access Type | mixed |
| Reset Value | 0x00000000 |
| Description | Default Type DMA Channel 7 |

Register XDmaPs_FTCn_OFFSET_7 Details

| Field Name | Bits | Type | Reset Value | Description |
|---------------------|-------|---------------------------|-------------|---|
| lockup_err | 31 | sro,ns sraz,n snsro | 0x0 | Indicates whether the DMA channel thread has locked-up because of resource starvation: 0: DMA channel has adequate resources 1: DMA channel has locked-up because of insufficient resources. This fault is an imprecise abort. |
| dbg_instr | 30 | sro,ns sraz,n snsro | 0x0 | If the DMA channel aborts, this bit indicates whether the erroneous instruction was read from the system memory or from the debug interface: 0: system memory 1: debug interface. |
| reserved | 29:19 | sro,nss raz,ns nsro | 0x0 | read undefined |
| data_read_err | 18 | sro,ns sraz,n snsro | 0x0 | Indicates the AXI response that the DMAC receives on the RRESP bus, after the DMA channel thread performs a data read: 0: OKAY response 1: EXOKAY, SLVERR, or DECERR response. This fault is an imprecise abort. |
| data_write_err | 17 | sro,ns sraz,n snsro | 0x0 | Indicates the AXI response that the DMAC receives on the BRESP bus, after the DMA channel thread performs a data write: 0: OKAY response 1: EXOKAY, SLVERR, or DECERR response. This fault is an imprecise abort. |
| instr_fetch_err | 16 | sro,ns sraz,n snsro | 0x0 | Indicates the AXI response that the DMAC receives on the RRESP bus after the DMA channel thread performs an instruction fetch: 0: OKAY response 1: EXOKAY, SLVERR, or DECERR response. This fault is a precise abort. |
| reserved | 15:14 | sro,nss raz,ns nsro | 0x0 | read undefined |
| st_data_unavailable | 13 | sro,ns sraz,n snsro | 0x0 | Indicates whether the MFIFO did not contain the data to enable the DMAC to perform the DMAST: 0: MFIFO contains all the data to enable the DMAST to complete 1: previous DMALDs have not put enough data in the MFIFO to enable the DMAST to complete. This fault is a precise abort. |

| Field Name | Bits | Type | Reset Value | Description |
|---------------|------|---------------------------|-------------|--|
| mfifo_err | 12 | sro,ns sraz,n snsro | 0x0 | Indicates whether the MFIFO prevented the DMA channel thread from executing DMALD or DMAST: DMALD: 0: MFIFO contains sufficient space 1: MFIFO is too small to hold the data that DMALD requires. DMAST: 0: MFIFO contains sufficient data 1: MFIFO is too small to store the data to enable DMAST to complete. This fault is an imprecise abort. |
| reserved | 11:8 | sro,nss raz,ns nsro | 0x0 | read undefined |
| ch_rdwr_err | 7 | sro,ns sraz,n snsro | 0x0 | Indicates whether a DMA channel thread, in the Non-secure state, attempts to program the CCR registers to perform a secure read or secure write: 0: a DMA channel thread in the Non-secure state is not violating the security permissions 1: a DMA channel thread in the Non-secure state attempted to perform a secure read or secure write. This fault is a precise abort. |
| ch_periph_err | 6 | sro,ns sraz,n snsro | 0x0 | Indicates whether a DMA channel thread, in the Non-secure state, attempts to execute DMAWFP, DMALDP, DMASTP, or DMAFLUSHP with inappropriate security permissions: 0: a DMA channel thread in the Non-secure state is not violating the security permissions 1: a DMA channel thread in the Non-secure state attempted to execute either: a) DMAWFP to wait for a secure peripheral, b) DMALDP or DMASTP to notify a secure peripheral, or c) DMAFLUSHP to flush a secure peripheral. This fault is a precise abort. |
| ch_evnt_err | 5 | sro,ns sraz,n snsro | 0x0 | Indicates whether the DMA channel thread attempts to execute DMAWFE or DMASEV with inappropriate security permissions: 0: a DMA channel thread in the Non-secure state is not violating the security permissions 1: a DMA channel thread in the Non-secure state attempted to execute either: a) DMAWFE to wait for a secure event, or b) DMASEV to create a secure event or secure interrupt. This fault is a precise abort. |
| reserved | 4:2 | sro,nss raz,ns nsro | 0x0 | read undefined |

| Field Name | Bits | Type | Reset Value | Description |
|-----------------|------|---------------------------|-------------|--|
| operand_invalid | 1 | sro,ns sraz,n snsro | 0x0 | Indicates whether the DMA channel thread was attempting to execute an instruction operand that was not valid for the configuration of the DMAC: 0: valid operand 1: invalid operand. This fault is a precise abort. |
| undef_instr | 0 | sro,ns sraz,n snsro | 0x0 | Indicates whether the DMA channel thread was attempting to execute an undefined instruction: 0: defined instruction 1: undefined instruction. This fault is a precise abort. |

Register ([dmac](#)) XDMAPS_CS0_OFFSET

| | |
|------------------|---|
| Name | XDMAPS_CS0_OFFSET |
| Software Name | CS0 |
| Relative Address | 0x00000100 |
| Absolute Address | dmac0_ns: 0xF8004100 dmac0_s: 0xF8003100 |
| Width | 32 bits |
| Access Type | mixed |
| Reset Value | 0x00000000 |
| Description | Channel Status DMA Channel 0 |

Register XDMAPS_CS0_OFFSET Details

| Field Name | Bits | Type | Reset Value | Description |
|---------------|-------|---------------------------|-------------|--|
| reserved | 31:22 | rud | 0x0 | reserved,read undefined |
| CNS | 21 | sro,ns sraz,n snsro | 0x0 | Security status of the DMA channel thread: 0: Secure state 1: Non-secure state. |
| reserved | 20:16 | rud | 0x0 | reserved,read undefined |
| dmawfp_periph | 15 | sro,ns sraz,n snsro | 0x0 | When the DMA channel thread executes DMAWFP, this bit indicates whether the periph operand is set: 0: periph operand not set 1: periph operand set. Note: the status only applies when the channel is connected to one of the four peripheral request interfaces. |

| Field Name | Bits | Type | Reset Value | Description |
|----------------|------|---------------------------|-------------|--|
| dmawfp_b_ns | 14 | sro,ns sraz,n snsro | 0x0 | When the DMA channel thread executes DMAWFP, this bit indicates whether the burst or single operand were set: 0: single operand set 1: burst operand set |
| reserved | 13:9 | rud | 0x0 | reserved |
| wakeup_num | 8:4 | sro,ns sraz,n snsro | 0x0 | When the DMA channel thread executes a WFE or WFP instruction, these bits indicate the event or peripheral number that the channel is waiting for: Waiting for Event (WFE): 0 0000: waiting for event 0 0 0001: waiting for event 1 ... 0 1111: waiting for event 15 1 xxxx: reserved Waiting for Peripheral (WFP): 0 0000: waiting for peripheral 0 0 0001: waiting for peripheral 1 0 0010: waiting for peripheral 2 0 0011: waiting for peripheral 3 1 11xx: reserved |
| channel_status | 3:0 | sro,ns sraz,n snsro | 0x0 | The channel status encoding is: 0000: Stopped 0001: Executing 0010: Cache miss 0011: Updating PC 0100: Waiting for event 0101: At barrier 0110: reserved 0111: Waiting for peripheral 1000: Killing 1001: Completing 1010 to 1101: reserved 1110: Faulting completing 1111: Faulting. |

Register ([dmac](#)) XDMAPS_CPC0_OFFSET

| | |
|------------------|---|
| Name | XDMAPS_CPC0_OFFSET |
| Software Name | CPC0 |
| Relative Address | 0x00000104 |
| Absolute Address | dmac0_ns: 0xF8004104 dmac0_s: 0xF8003104 |
| Width | 32 bits |
| Access Type | mixed |

Reset Value 0x00000000
 Description Channel PC for DMA Channel 0

Register XDMAPS_CPC0_OFFSET Details

| Field Name | Bits | Type | Reset Value | Description |
|------------|------|---------------------------|-------------|---|
| pc_chnl | 31:0 | sro,ns sraz,n snsro | 0x0 | Program counter (physical memory address) for DMA channel thread. |

Register ([dmac](#)) XDmaPs_CSn_OFFSET_1

Name XDmaPs_CSn_OFFSET_1
 Relative Address 0x00000108
 Absolute Address dmac0_ns: 0xF8004108
 dmac0_s: 0xF8003108
 Width 32 bits
 Access Type mixed
 Reset Value 0x00000000
 Description Channel Status DMA Channel 1

Register XDmaPs_CSn_OFFSET_1 Details

| Field Name | Bits | Type | Reset Value | Description |
|---------------|-------|---------------------------|-------------|--|
| reserved | 31:22 | rud | 0x0 | reserved,read undefined |
| CNS | 21 | sro,ns sraz,n snsro | 0x0 | Security status of the DMA channel thread: 0: Secure state 1: Non-secure state. |
| reserved | 20:16 | rud | 0x0 | reserved,read undefined |
| dmawfp_periph | 15 | sro,ns sraz,n snsro | 0x0 | When the DMA channel thread executes DMAWFP, this bit indicates whether the periph operand is set: 0: periph operand not set 1: periph operand set. Note: the status only applies when the channel is connected to one of the four peripheral request interfaces. |
| dmawfp_b_ns | 14 | sro,ns sraz,n snsro | 0x0 | When the DMA channel thread executes DMAWFP, this bit indicates whether the burst or single operand were set: 0: single operand set 1: burst operand set |
| reserved | 13:9 | rud | 0x0 | reserved |

| Field Name | Bits | Type | Reset Value | Description |
|----------------|------|---------------------------|-------------|--|
| wakeup_num | 8:4 | sro,ns sraz,n snsro | 0x0 | When the DMA channel thread executes a WFE or WFP instruction, these bits indicate the event or peripheral number that the channel is waiting for: Waiting for Event (WFE): 0 0000: waiting for event 0 0 0001: waiting for event 1 ... 0 1111: waiting for event 15 1 xxxx: reserved Waiting for Peripheral (WFP): 0 0000: waiting for peripheral 0 0 0001: waiting for peripheral 1 0 0010: waiting for peripheral 2 0 0011: waiting for peripheral 3 1 11xx: reserved |
| channel_status | 3:0 | sro,ns sraz,n snsro | 0x0 | The channel status encoding is: 0000: Stopped 0001: Executing 0010: Cache miss 0011: Updating PC 0100: Waiting for event 0101: At barrier 0110: reserved 0111: Waiting for peripheral 1000: Killing 1001: Completing 1010 to 1101: reserved 1110: Faulting completing 1111: Faulting. |

Register ([dmac](#)) XDmaPs_CPCn_OFFSET_1

| | |
|------------------|---|
| Name | XDmaPs_CPCn_OFFSET_1 |
| Relative Address | 0x0000010C |
| Absolute Address | dmac0_ns: 0xF800410C dmac0_s: 0xF800310C |
| Width | 32 bits |
| Access Type | mixed |
| Reset Value | 0x00000000 |
| Description | Channel PC for DMA Channel 1 |

Register XDmaPs_CPCn_OFFSET_1 Details

| Field Name | Bits | Type | Reset Value | Description |
|------------|------|---------------------------|-------------|---|
| pc_chnl | 31:0 | sro,ns sraz,n snsro | 0x0 | Program counter (physical memory address) for DMA channel thread. |

Register ([dmac](#)) XDmaPs_CSn_OFFSET_2

| | |
|------------------|---|
| Name | XDmaPs_CSn_OFFSET_2 |
| Relative Address | 0x00000110 |
| Absolute Address | dmac0_ns: 0xF8004110 dmac0_s: 0xF8003110 |
| Width | 32 bits |
| Access Type | mixed |
| Reset Value | 0x00000000 |
| Description | Channel Status DMA Channel 2 |

Register XDmaPs_CSn_OFFSET_2 Details

| Field Name | Bits | Type | Reset Value | Description |
|---------------|-------|---------------------------|-------------|--|
| reserved | 31:22 | rud | 0x0 | reserved,read undefined |
| CNS | 21 | sro,ns sraz,n snsro | 0x0 | Security status of the DMA channel thread: 0: Secure state 1: Non-secure state. |
| reserved | 20:16 | rud | 0x0 | reserved,read undefined |
| dmawfp_periph | 15 | sro,ns sraz,n snsro | 0x0 | When the DMA channel thread executes DMAWFP, this bit indicates whether the periph operand is set: 0: periph operand not set 1: periph operand set. Note: the status only applies when the channel is connected to one of the four peripheral request interfaces. |
| dmawfp_b_ns | 14 | sro,ns sraz,n snsro | 0x0 | When the DMA channel thread executes DMAWFP, this bit indicates whether the burst or single operand were set: 0: single operand set 1: burst operand set |
| reserved | 13:9 | rud | 0x0 | reserved |

| Field Name | Bits | Type | Reset Value | Description |
|----------------|------|---------------------------|-------------|--|
| wakeup_num | 8:4 | sro,ns sraz,n snsro | 0x0 | When the DMA channel thread executes a WFE or WFP instruction, these bits indicate the event or peripheral number that the channel is waiting for: Waiting for Event (WFE): 0 0000: waiting for event 0 0 0001: waiting for event 1 ... 0 1111: waiting for event 15 1 xxxx: reserved Waiting for Peripheral (WFP): 0 0000: waiting for peripheral 0 0 0001: waiting for peripheral 1 0 0010: waiting for peripheral 2 0 0011: waiting for peripheral 3 1 11xx: reserved |
| channel_status | 3:0 | sro,ns sraz,n snsro | 0x0 | The channel status encoding is: 0000: Stopped 0001: Executing 0010: Cache miss 0011: Updating PC 0100: Waiting for event 0101: At barrier 0110: reserved 0111: Waiting for peripheral 1000: Killing 1001: Completing 1010 to 1101: reserved 1110: Faulting completing 1111: Faulting. |

Register ([dmac](#)) XDmaPs_CPCn_OFFSET_2

| | |
|------------------|---|
| Name | XDmaPs_CPCn_OFFSET_2 |
| Relative Address | 0x00000114 |
| Absolute Address | dmac0_ns: 0xF8004114 dmac0_s: 0xF8003114 |
| Width | 32 bits |
| Access Type | mixed |
| Reset Value | 0x00000000 |
| Description | Channel PC for DMA Channel 2 |

Register XDmaPs_CPCn_OFFSET_2 Details

| Field Name | Bits | Type | Reset Value | Description |
|------------|------|---------------------------|-------------|---|
| pc_chnl | 31:0 | sro,ns sraz,n snsro | 0x0 | Program counter (physical memory address) for DMA channel thread. |

Register ([dmac](#)) XDmaPs_CSn_OFFSET_3

| | |
|------------------|---|
| Name | XDmaPs_CSn_OFFSET_3 |
| Relative Address | 0x00000118 |
| Absolute Address | dmac0_ns: 0xF8004118 dmac0_s: 0xF8003118 |
| Width | 32 bits |
| Access Type | mixed |
| Reset Value | 0x00000000 |
| Description | Channel Status DMA Channel 3 |

Register XDmaPs_CSn_OFFSET_3 Details

| Field Name | Bits | Type | Reset Value | Description |
|---------------|-------|---------------------------|-------------|--|
| reserved | 31:22 | rud | 0x0 | reserved,read undefined |
| CNS | 21 | sro,ns sraz,n snsro | 0x0 | Security status of the DMA channel thread: 0: Secure state 1: Non-secure state. |
| reserved | 20:16 | rud | 0x0 | reserved,read undefined |
| dmawfp_periph | 15 | sro,ns sraz,n snsro | 0x0 | When the DMA channel thread executes DMAWFP, this bit indicates whether the periph operand is set: 0: periph operand not set 1: periph operand set. Note: the status only applies when the channel is connected to one of the four peripheral request interfaces. |
| dmawfp_b_ns | 14 | sro,ns sraz,n snsro | 0x0 | When the DMA channel thread executes DMAWFP, this bit indicates whether the burst or single operand were set: 0: single operand set 1: burst operand set |
| reserved | 13:9 | rud | 0x0 | reserved |

| Field Name | Bits | Type | Reset Value | Description |
|----------------|------|---------------------------|-------------|--|
| wakeup_num | 8:4 | sro,ns sraz,n snsro | 0x0 | When the DMA channel thread executes a WFE or WFP instruction, these bits indicate the event or peripheral number that the channel is waiting for: Waiting for Event (WFE): 0 0000: waiting for event 0 0 0001: waiting for event 1 ... 0 1111: waiting for event 15 1 xxxx: reserved Waiting for Peripheral (WFP): 0 0000: waiting for peripheral 0 0 0001: waiting for peripheral 1 0 0010: waiting for peripheral 2 0 0011: waiting for peripheral 3 1 11xx: reserved |
| channel_status | 3:0 | sro,ns sraz,n snsro | 0x0 | The channel status encoding is: 0000: Stopped 0001: Executing 0010: Cache miss 0011: Updating PC 0100: Waiting for event 0101: At barrier 0110: reserved 0111: Waiting for peripheral 1000: Killing 1001: Completing 1010 to 1101: reserved 1110: Faulting completing 1111: Faulting. |

Register ([dmac](#)) XDmaPs_CPCn_OFFSET_3

| | |
|------------------|---|
| Name | XDmaPs_CPCn_OFFSET_3 |
| Relative Address | 0x0000011C |
| Absolute Address | dmac0_ns: 0xF800411C dmac0_s: 0xF800311C |
| Width | 32 bits |
| Access Type | mixed |
| Reset Value | 0x00000000 |
| Description | Channel PC for DMA Channel 3 |

Register XDmaPs_CPCn_OFFSET_3 Details

| Field Name | Bits | Type | Reset Value | Description |
|------------|------|---------------------------|-------------|---|
| pc_chnl | 31:0 | sro,ns sraz,n snsro | 0x0 | Program counter (physical memory address) for DMA channel thread. |

Register ([dmac](#)) XDmaPs_CSn_OFFSET_4

| | |
|------------------|---|
| Name | XDmaPs_CSn_OFFSET_4 |
| Relative Address | 0x00000120 |
| Absolute Address | dmac0_ns: 0xF8004120 dmac0_s: 0xF8003120 |
| Width | 32 bits |
| Access Type | mixed |
| Reset Value | 0x00000000 |
| Description | Channel Status DMA Channel 4 |

Register XDmaPs_CSn_OFFSET_4 Details

| Field Name | Bits | Type | Reset Value | Description |
|---------------|-------|---------------------------|-------------|--|
| reserved | 31:22 | rud | 0x0 | reserved,read undefined |
| CNS | 21 | sro,ns sraz,n snsro | 0x0 | Security status of the DMA channel thread: 0: Secure state 1: Non-secure state. |
| reserved | 20:16 | rud | 0x0 | reserved,read undefined |
| dmawfp_periph | 15 | sro,ns sraz,n snsro | 0x0 | When the DMA channel thread executes DMAWFP, this bit indicates whether the periph operand is set: 0: periph operand not set 1: periph operand set. Note: the status only applies when the channel is connected to one of the four peripheral request interfaces. |
| dmawfp_b_ns | 14 | sro,ns sraz,n snsro | 0x0 | When the DMA channel thread executes DMAWFP, this bit indicates whether the burst or single operand were set: 0: single operand set 1: burst operand set |
| reserved | 13:9 | rud | 0x0 | reserved |

| Field Name | Bits | Type | Reset Value | Description |
|----------------|------|---------------------------|-------------|--|
| wakeup_num | 8:4 | sro,ns sraz,n snsro | 0x0 | When the DMA channel thread executes a WFE or WFP instruction, these bits indicate the event or peripheral number that the channel is waiting for: Waiting for Event (WFE): 0 0000: waiting for event 0 0 0001: waiting for event 1 ... 0 1111: waiting for event 15 1 xxxx: reserved Waiting for Peripheral (WFP): 0 0000: waiting for peripheral 0 0 0001: waiting for peripheral 1 0 0010: waiting for peripheral 2 0 0011: waiting for peripheral 3 1 11xx: reserved |
| channel_status | 3:0 | sro,ns sraz,n snsro | 0x0 | The channel status encoding is: 0000: Stopped 0001: Executing 0010: Cache miss 0011: Updating PC 0100: Waiting for event 0101: At barrier 0110: reserved 0111: Waiting for peripheral 1000: Killing 1001: Completing 1010 to 1101: reserved 1110: Faulting completing 1111: Faulting. |

Register ([dmac](#)) XDmaPs_CPCn_OFFSET_4

| | |
|------------------|---|
| Name | XDmaPs_CPCn_OFFSET_4 |
| Relative Address | 0x00000124 |
| Absolute Address | dmac0_ns: 0xF8004124 dmac0_s: 0xF8003124 |
| Width | 32 bits |
| Access Type | mixed |
| Reset Value | 0x00000000 |
| Description | Channel PC for DMA Channel 4 |

Register XDmaPs_CPCn_OFFSET_4 Details

| Field Name | Bits | Type | Reset Value | Description |
|------------|------|---------------------------|-------------|---|
| pc_chnl | 31:0 | sro,ns sraz,n snsro | 0x0 | Program counter (physical memory address) for DMA channel thread. |

Register ([dmac](#)) XDmaPs_CSn_OFFSET_5

| | |
|------------------|---|
| Name | XDmaPs_CSn_OFFSET_5 |
| Relative Address | 0x00000128 |
| Absolute Address | dmac0_ns: 0xF8004128 dmac0_s: 0xF8003128 |
| Width | 32 bits |
| Access Type | mixed |
| Reset Value | 0x00000000 |
| Description | Channel Status DMA Channel 5 |

Register XDmaPs_CSn_OFFSET_5 Details

| Field Name | Bits | Type | Reset Value | Description |
|---------------|-------|---------------------------|-------------|--|
| reserved | 31:22 | rud | 0x0 | reserved,read undefined |
| CNS | 21 | sro,ns sraz,n snsro | 0x0 | Security status of the DMA channel thread: 0: Secure state 1: Non-secure state. |
| reserved | 20:16 | rud | 0x0 | reserved,read undefined |
| dmawfp_periph | 15 | sro,ns sraz,n snsro | 0x0 | When the DMA channel thread executes DMAWFP, this bit indicates whether the periph operand is set: 0: periph operand not set 1: periph operand set. Note: the status only applies when the channel is connected to one of the four peripheral request interfaces. |
| dmawfp_b_ns | 14 | sro,ns sraz,n snsro | 0x0 | When the DMA channel thread executes DMAWFP, this bit indicates whether the burst or single operand were set: 0: single operand set 1: burst operand set |
| reserved | 13:9 | rud | 0x0 | reserved |

| Field Name | Bits | Type | Reset Value | Description |
|----------------|------|---------------------------|-------------|--|
| wakeup_num | 8:4 | sro,ns sraz,n snsro | 0x0 | When the DMA channel thread executes a WFE or WFP instruction, these bits indicate the event or peripheral number that the channel is waiting for: Waiting for Event (WFE): 0 0000: waiting for event 0 0 0001: waiting for event 1 ... 0 1111: waiting for event 15 1 xxxx: reserved Waiting for Peripheral (WFP): 0 0000: waiting for peripheral 0 0 0001: waiting for peripheral 1 0 0010: waiting for peripheral 2 0 0011: waiting for peripheral 3 1 11xx: reserved |
| channel_status | 3:0 | sro,ns sraz,n snsro | 0x0 | The channel status encoding is: 0000: Stopped 0001: Executing 0010: Cache miss 0011: Updating PC 0100: Waiting for event 0101: At barrier 0110: reserved 0111: Waiting for peripheral 1000: Killing 1001: Completing 1010 to 1101: reserved 1110: Faulting completing 1111: Faulting. |

Register ([dmac](#)) XDmaPs_CPCn_OFFSET_5

| | |
|------------------|---|
| Name | XDmaPs_CPCn_OFFSET_5 |
| Relative Address | 0x0000012C |
| Absolute Address | dmac0_ns: 0xF800412C dmac0_s: 0xF800312C |
| Width | 32 bits |
| Access Type | mixed |
| Reset Value | 0x00000000 |
| Description | Channel PC for DMA Channel 5 |

Register XDmaPs_CPCn_OFFSET_5 Details

| Field Name | Bits | Type | Reset Value | Description |
|------------|------|---------------------------|-------------|---|
| pc_chnl | 31:0 | sro,ns sraz,n snsro | 0x0 | Program counter (physical memory address) for DMA channel thread. |

Register ([dmac](#)) XDmaPs_CSn_OFFSET_6

| | |
|------------------|---|
| Name | XDmaPs_CSn_OFFSET_6 |
| Relative Address | 0x00000130 |
| Absolute Address | dmac0_ns: 0xF8004130 dmac0_s: 0xF8003130 |
| Width | 32 bits |
| Access Type | mixed |
| Reset Value | 0x00000000 |
| Description | Channel Status DMA Channel 6 |

Register XDmaPs_CSn_OFFSET_6 Details

| Field Name | Bits | Type | Reset Value | Description |
|---------------|-------|---------------------------|-------------|--|
| reserved | 31:22 | rud | 0x0 | reserved,read undefined |
| CNS | 21 | sro,ns sraz,n snsro | 0x0 | Security status of the DMA channel thread: 0: Secure state 1: Non-secure state. |
| reserved | 20:16 | rud | 0x0 | reserved,read undefined |
| dmawfp_periph | 15 | sro,ns sraz,n snsro | 0x0 | When the DMA channel thread executes DMAWFP, this bit indicates whether the periph operand is set: 0: periph operand not set 1: periph operand set. Note: the status only applies when the channel is connected to one of the four peripheral request interfaces. |
| dmawfp_b_ns | 14 | sro,ns sraz,n snsro | 0x0 | When the DMA channel thread executes DMAWFP, this bit indicates whether the burst or single operand were set: 0: single operand set 1: burst operand set |
| reserved | 13:9 | rud | 0x0 | reserved |

| Field Name | Bits | Type | Reset Value | Description |
|----------------|------|---------------------------|-------------|--|
| wakeup_num | 8:4 | sro,ns sraz,n snsro | 0x0 | When the DMA channel thread executes a WFE or WFP instruction, these bits indicate the event or peripheral number that the channel is waiting for: Waiting for Event (WFE): 0 0000: waiting for event 0 0 0001: waiting for event 1 ... 0 1111: waiting for event 15 1 xxxx: reserved Waiting for Peripheral (WFP): 0 0000: waiting for peripheral 0 0 0001: waiting for peripheral 1 0 0010: waiting for peripheral 2 0 0011: waiting for peripheral 3 1 11xx: reserved |
| channel_status | 3:0 | sro,ns sraz,n snsro | 0x0 | The channel status encoding is: 0000: Stopped 0001: Executing 0010: Cache miss 0011: Updating PC 0100: Waiting for event 0101: At barrier 0110: reserved 0111: Waiting for peripheral 1000: Killing 1001: Completing 1010 to 1101: reserved 1110: Faulting completing 1111: Faulting. |

Register ([dmac](#)) XDmaPs_CPCn_OFFSET_6

| | |
|------------------|---|
| Name | XDmaPs_CPCn_OFFSET_6 |
| Relative Address | 0x00000134 |
| Absolute Address | dmac0_ns: 0xF8004134 dmac0_s: 0xF8003134 |
| Width | 32 bits |
| Access Type | mixed |
| Reset Value | 0x00000000 |
| Description | Channel PC for DMA Channel 6 |

Register XDmaPs_CPCn_OFFSET_6 Details

| Field Name | Bits | Type | Reset Value | Description |
|------------|------|---------------------------|-------------|---|
| pc_chnl | 31:0 | sro,ns sraz,n snsro | 0x0 | Program counter (physical memory address) for DMA channel thread. |

Register ([dmac](#)) XDmaPs_CSn_OFFSET_7

| | |
|------------------|---|
| Name | XDmaPs_CSn_OFFSET_7 |
| Relative Address | 0x00000138 |
| Absolute Address | dmac0_ns: 0xF8004138 dmac0_s: 0xF8003138 |
| Width | 32 bits |
| Access Type | mixed |
| Reset Value | 0x00000000 |
| Description | Channel Status DMA Channel 7 |

Register XDmaPs_CSn_OFFSET_7 Details

| Field Name | Bits | Type | Reset Value | Description |
|---------------|-------|---------------------------|-------------|--|
| reserved | 31:22 | rud | 0x0 | reserved,read undefined |
| CNS | 21 | sro,ns sraz,n snsro | 0x0 | Security status of the DMA channel thread: 0: Secure state 1: Non-secure state. |
| reserved | 20:16 | rud | 0x0 | reserved,read undefined |
| dmawfp_periph | 15 | sro,ns sraz,n snsro | 0x0 | When the DMA channel thread executes DMAWFP, this bit indicates whether the periph operand is set: 0: periph operand not set 1: periph operand set. Note: the status only applies when the channel is connected to one of the four peripheral request interfaces. |
| dmawfp_b_ns | 14 | sro,ns sraz,n snsro | 0x0 | When the DMA channel thread executes DMAWFP, this bit indicates whether the burst or single operand were set: 0: single operand set 1: burst operand set |
| reserved | 13:9 | rud | 0x0 | reserved |

| Field Name | Bits | Type | Reset Value | Description |
|----------------|------|---------------------------|-------------|--|
| wakeup_num | 8:4 | sro,ns sraz,n snsro | 0x0 | When the DMA channel thread executes a WFE or WFP instruction, these bits indicate the event or peripheral number that the channel is waiting for: Waiting for Event (WFE): 0 0000: waiting for event 0 0 0001: waiting for event 1 ... 0 1111: waiting for event 15 1 xxxx: reserved Waiting for Peripheral (WFP): 0 0000: waiting for peripheral 0 0 0001: waiting for peripheral 1 0 0010: waiting for peripheral 2 0 0011: waiting for peripheral 3 1 11xx: reserved |
| channel_status | 3:0 | sro,ns sraz,n snsro | 0x0 | The channel status encoding is: 0000: Stopped 0001: Executing 0010: Cache miss 0011: Updating PC 0100: Waiting for event 0101: At barrier 0110: reserved 0111: Waiting for peripheral 1000: Killing 1001: Completing 1010 to 1101: reserved 1110: Faulting completing 1111: Faulting. |

Register ([dmac](#)) XDmaPs_CPCn_OFFSET_7

| | |
|------------------|---|
| Name | XDmaPs_CPCn_OFFSET_7 |
| Relative Address | 0x0000013C |
| Absolute Address | dmac0_ns: 0xF800413C dmac0_s: 0xF800313C |
| Width | 32 bits |
| Access Type | mixed |
| Reset Value | 0x00000000 |
| Description | Channel PC for DMA Channel 7 |

Register XDmaPs_CPCn_OFFSET_7 Details

| Field Name | Bits | Type | Reset Value | Description |
|------------|------|---------------------------|-------------|---|
| pc_chnl | 31:0 | sro,ns sraz,n snsro | 0x0 | Program counter (physical memory address) for DMA channel thread. |

Register ([dmac](#)) XDMAPS_SA_0_OFFSET

| | |
|------------------|---|
| Name | XDMAPS_SA_0_OFFSET |
| Software Name | SA_0 |
| Relative Address | 0x00000400 |
| Absolute Address | dmac0_ns: 0xF8004400 dmac0_s: 0xF8003400 |
| Width | 32 bits |
| Access Type | mixed |
| Reset Value | 0x00000000 |
| Description | Source Address DMA Channel 0 |

Register XDMAPS_SA_0_OFFSET Details

| Field Name | Bits | Type | Reset Value | Description |
|------------|------|---------------------------|-------------|---|
| src_addr | 31:0 | sro,ns sraz,n snsro | 0x0 | Source data address (physical memory address) for DMA channel thread. |

Register ([dmac](#)) XDMAPS_DA_0_OFFSET

| | |
|------------------|---|
| Name | XDMAPS_DA_0_OFFSET |
| Software Name | DA_0 |
| Relative Address | 0x00000404 |
| Absolute Address | dmac0_ns: 0xF8004404 dmac0_s: 0xF8003404 |
| Width | 32 bits |
| Access Type | mixed |
| Reset Value | 0x00000000 |
| Description | Destination Addr DMA Channel 0 |

Register XDMAPS_DA_0_OFFSET Details

| Field Name | Bits | Type | Reset Value | Description |
|------------|------|---------------------------|-------------|--|
| dest_addr | 31:0 | sro,ns sraz,n snsro | 0x0 | Destination data address (physical memory address) for DMA channel thread. |

Register ([dmac](#)) XDMAPS_CC_0_OFFSET

| | |
|------------------|---|
| Name | XDMAPS_CC_0_OFFSET |
| Software Name | CC_0 |
| Relative Address | 0x00000408 |
| Absolute Address | dmac0_ns: 0xF8004408 dmac0_s: 0xF8003408 |
| Width | 32 bits |
| Access Type | mixed |
| Reset Value | dmac0_ns: 0x00000000 dmac0_s: 0x00800200 |
| Description | Channel Control DMA Channel 0 |

Register XDMAPS_CC_0_OFFSET Details

| Field Name | Bits | Type | Reset Value | Description |
|------------------|-------|---------------------------|-------------|---|
| reserved | 31 | rud | 0x0 | reserved, read undefined |
| endian_swap_size | 30:28 | sro,ns sraz,n snsro | 0x0 | Data swap: little-endian and byte-invariant big-endian (BE-8) formats. 000: No swap, 8-bit data 001: Swap bytes within 16-bit data 010: Swap bytes within 32-bit data 011: Swap bytes within 64-bit data 100: Swap bytes within 128-bit data 101 to 111: Reserved |
| dst_cache_ctrl | 27:25 | sro,ns sraz,n snsro | 0x0 | Programs the AXI AWCACHE signals that are used when the DMAC writes to the destination (0: Low, 1: High): Bit [27] programs AWCACHE[3] Hardwired Low to AWCACHE[2] Bit [26] programs AWCACHE[1] Bit [25] programs AWCACHE[0] Note: Setting AWCACHE[3,1]=b10 violates the AXI protocol. |

| Field Name | Bits | Type | Reset Value | Description |
|----------------|-------|---------------------------|-------------------------------|---|
| dst_prot_ctrl | 24:22 | sro,ns sraz,n snsro | dmac0_ns: 0x0 dmac0_s: 0x2 | <p>Programs the AWPROT signals that are used when the DMAC writes the destination data (0: Low, 1: High):</p> <p>Bit [24] programs AWPROT[2] Bit [23] programs AWPROT[1] Bit [22] programs AWPROT[0]</p> <p>Note: Only DMA channels in the Secure state can program AWPROT[1] Low, that is, a secure access. If a DMA channel in the Non-secure state attempts to set AWPROT[1] Low, then the DMA channel aborts.</p> |
| dst_burst_len | 21:18 | sro,ns sraz,n snsro | 0x0 | <p>For each burst, these bits program the number of data transfers that the DMAC performs when it writes the destination data:</p> <p>0000: 1 data transfer 0001: 2 data transfers 0010: 3 data transfers ... 1111: 16 data transfers.</p> <p>The total number of bytes that the DMAC writes out of the MFIFO when it executes a DMAST instruction is the product of dst_burst_len and dst_burst_size.</p> <p>Note: These bits control the state of AWLEN[3:0].</p> |
| dst_burst_size | 17:15 | sro,ns sraz,n snsro | 0x0 | <p>For each beat within a burst, it programs the number of bytes that the DMAC writes to the destination:</p> <p>000: writes 1 byte per beat 001: writes 2 bytes per beat 010: writes 4 bytes per beat 011: writes 8 bytes per beat 100: writes 16 bytes per beat 101 to 111: reserved.</p> <p>The total number of bytes that the DMAC writes out of the MFIFO when it executes a DMAST instruction is the product of dst_burst_len and dst_burst_size. Note: These bits control the state of AWSIZE[2:0].</p> |
| dst_inc | 14 | sro,ns sraz,n snsro | 0x0 | <p>Programs the burst type that the DMAC performs when it writes the destination data:</p> <p>0: Fixed-address burst. The DMAC signals AWBURST[0] Low. 1: Incrementing-address burst. The DMAC signals AWBURST[0] High.</p> |

| Field Name | Bits | Type | Reset Value | Description |
|----------------|-------|---------------------------|-------------------------------|--|
| src_cache_ctrl | 13:11 | sro,ns sraz,n snsro | 0x0 | Programs the AXI ARCACHE signals that are used for DMA reads of the source data (0: Low, 1: High): Bit [13] programs ARCACHE[2] Bit [12] programs ARCACHE[1] Bit [11] programs ARCACHE[0] Note: The DMAC ties ARCACHE[3] Low. Setting ARCACHE[2:1]= b10 violates the AXI protocol. |
| src_prot_ctrl | 10:8 | sro,ns sraz,n snsro | dmac0_ns: 0x0 dmac0_s: 0x2 | Programs the AXI ARPROT signals that are used for DMA reads of the source data (0: Low, 1: High): Bit [10] programs ARPROT[2] Bit [9] programs ARPROT[1] Bit [8] programs ARPROT[0] Note: Only DMA channels in the Secure state can program ARPROT[1] Low, that is, a secure access. If a DMA channel in the Non-secure state attempts to set ARPROT[1] Low, the DMA channel aborts. |
| src_burst_len | 7:4 | sro,ns sraz,n snsro | 0x0 | For each burst, these bits program the number of data transfers that the DMAC performs when it reads the source data: 0000: 1 data transfer 0001: 2 data transfers ... 1111: 16 data transfers. The total number of bytes that the DMAC reads into the MFIFO when it executes a DMALD instruction is the product of src_burst_len and src_burst_size. Note: These bits control the state of ARLEN[3:0]. |
| src_burst_size | 3:1 | sro,ns sraz,n snsro | 0x0 | For each beat within a burst, it programs the number of bytes that the DMAC reads from the source: 000: reads 1 byte per beat 001: reads 2 bytes per beat 010: reads 4 bytes per beat 011: reads 8 bytes per beat 100: reads 16 bytes per beat 101 to 111: reserved. The total number of bytes that the DMAC reads into the MFIFO when it executes a DMALD instruction is the product of src_burst_len and src_burst_size. Note: These bits control the state of ARSIZE[2:0]. |
| src_inc | 0 | sro,ns sraz,n snsro | 0x0 | Programs the burst type that the DMAC performs when it reads the source data: 0: Fixed-address burst, DMAC signal ARBURST[0] driven Low. 1: Incrementing-address burst, DMAC signal ARBURST[0] driven High. |

Register ([dmac](#)) XDMAPS_LC0_0_OFFSET

| | |
|------------------|---|
| Name | XDMAPS_LC0_0_OFFSET |
| Software Name | LC0_0 |
| Relative Address | 0x0000040C |
| Absolute Address | dmac0_ns: 0xF800440C dmac0_s: 0xF800340C |
| Width | 32 bits |
| Access Type | mixed |
| Reset Value | 0x00000000 |
| Description | Loop Counter 0 DMA Channel 0 |

Register XDMAPS_LC0_0_OFFSET Details

| Field Name | Bits | Type | Reset Value | Description |
|------------------------|------|---------------------------|-------------|--|
| reserved | 31:8 | rud | 0x0 | reserved, read undefined |
| loop_counter_iteration | 7:0 | sro,ns sraz,n snsro | 0x0 | Provides the status of loop counter zero for the DMA channel thread. The DMAC updates this register when it executes DMALPEND[S]B], and the DMA channel thread is programmed to use loop counter zero. |

Register ([dmac](#)) XDMAPS_LC1_0_OFFSET

| | |
|------------------|---|
| Name | XDMAPS_LC1_0_OFFSET |
| Software Name | LC1_0 |
| Relative Address | 0x00000410 |
| Absolute Address | dmac0_ns: 0xF8004410 dmac0_s: 0xF8003410 |
| Width | 32 bits |
| Access Type | mixed |
| Reset Value | 0x00000000 |
| Description | Loop Counter 1 DMA Channel 0 |

Register XDMAPS_LC1_0_OFFSET Details

| Field Name | Bits | Type | Reset Value | Description |
|------------------------|------|---------------------------|-------------|--|
| reserved | 31:8 | rud | 0x0 | reserved, read undefined |
| loop_counter_iteration | 7:0 | sro,ns sraz,n snsro | 0x0 | Provides the status of loop counter one for the DMA channel thread. The DMAC updates this register when it executes DMALPEND[S]B], and the DMA channel thread is programmed to use loop counter one. |

Register ([dmac](#)) XDmaPs_SA_n_OFFSET_1

| | |
|------------------|---|
| Name | XDmaPs_SA_n_OFFSET_1 |
| Relative Address | 0x00000420 |
| Absolute Address | dmac0_ns: 0xF8004420 dmac0_s: 0xF8003420 |
| Width | 32 bits |
| Access Type | mixed |
| Reset Value | 0x00000000 |
| Description | Source address DMA Channel 1 |

Register XDmaPs_SA_n_OFFSET_1 Details

| Field Name | Bits | Type | Reset Value | Description |
|------------|------|---------------------------|-------------|---|
| src_addr | 31:0 | sro,ns sraz,n snsro | 0x0 | Source data address (physical memory address) for DMA channel thread. |

Register ([dmac](#)) XDmaPs_DA_n_OFFSET_1

| | |
|------------------|---|
| Name | XDmaPs_DA_n_OFFSET_1 |
| Relative Address | 0x00000424 |
| Absolute Address | dmac0_ns: 0xF8004424 dmac0_s: 0xF8003424 |
| Width | 32 bits |
| Access Type | mixed |
| Reset Value | 0x00000000 |
| Description | Destination Addr DMA Channel 1 |

Register XDmaPs_DA_n_OFFSET_1 Details

| Field Name | Bits | Type | Reset Value | Description |
|------------|------|---------------------------|-------------|--|
| dest_addr | 31:0 | sro,ns sraz,n snsro | 0x0 | Destination data address (physical memory address) for DMA channel thread. |

Register ([dmac](#)) XDmaPs_CC_n_OFFSET_1

| | |
|------------------|---|
| Name | XDmaPs_CC_n_OFFSET_1 |
| Relative Address | 0x00000428 |
| Absolute Address | dmac0_ns: 0xF8004428 dmac0_s: 0xF8003428 |
| Width | 32 bits |
| Access Type | mixed |
| Reset Value | dmac0_ns: 0x00000000 dmac0_s: 0x00800200 |
| Description | Channel Control DMA Channel 1 |

Register XDmaPs_CC_n_OFFSET_1 Details

| Field Name | Bits | Type | Reset Value | Description |
|------------------|-------|---------------------------|-------------|---|
| reserved | 31 | rud | 0x0 | reserved, read undefined |
| endian_swap_size | 30:28 | sro,ns sraz,n snsro | 0x0 | Data swap: little-endian and byte-invariant big-endian (BE-8) formats. 000: No swap, 8-bit data 001: Swap bytes within 16-bit data 010: Swap bytes within 32-bit data 011: Swap bytes within 64-bit data 100: Swap bytes within 128-bit data 101 to 111: Reserved |
| dst_cache_ctrl | 27:25 | sro,ns sraz,n snsro | 0x0 | Programs the AXI AWCACHE signals that are used when the DMAC writes to the destination (0: Low, 1: High): Bit [27] programs AWCACHE[3] Hardwired Low to AWCACHE[2] Bit [26] programs AWCACHE[1] Bit [25] programs AWCACHE[0] Note: Setting AWCACHE[3,1]=b10 violates the AXI protocol. |

| Field Name | Bits | Type | Reset Value | Description |
|----------------|-------|---------------------------|-------------------------------|---|
| dst_prot_ctrl | 24:22 | sro,ns sraz,n snsro | dmac0_ns: 0x0 dmac0_s: 0x2 | <p>Programs the AWPROT signals that are used when the DMAC writes the destination data (0: Low, 1: High):</p> <p>Bit [24] programs AWPROT[2] Bit [23] programs AWPROT[1] Bit [22] programs AWPROT[0]</p> <p>Note: Only DMA channels in the Secure state can program AWPROT[1] Low, that is, a secure access. If a DMA channel in the Non-secure state attempts to set AWPROT[1] Low, then the DMA channel aborts.</p> |
| dst_burst_len | 21:18 | sro,ns sraz,n snsro | 0x0 | <p>For each burst, these bits program the number of data transfers that the DMAC performs when it writes the destination data:</p> <p>0000: 1 data transfer 0001: 2 data transfers 0010: 3 data transfers ... 1111: 16 data transfers.</p> <p>The total number of bytes that the DMAC writes out of the MFIFO when it executes a DMAST instruction is the product of dst_burst_len and dst_burst_size.</p> <p>Note: These bits control the state of AWLEN[3:0].</p> |
| dst_burst_size | 17:15 | sro,ns sraz,n snsro | 0x0 | <p>For each beat within a burst, it programs the number of bytes that the DMAC writes to the destination:</p> <p>000: writes 1 byte per beat 001: writes 2 bytes per beat 010: writes 4 bytes per beat 011: writes 8 bytes per beat 100: writes 16 bytes per beat 101 to 111: reserved.</p> <p>The total number of bytes that the DMAC writes out of the MFIFO when it executes a DMAST instruction is the product of dst_burst_len and dst_burst_size. Note: These bits control the state of AWSIZE[2:0].</p> |
| dst_inc | 14 | sro,ns sraz,n snsro | 0x0 | <p>Programs the burst type that the DMAC performs when it writes the destination data:</p> <p>0: Fixed-address burst. The DMAC signals AWBURST[0] Low. 1: Incrementing-address burst. The DMAC signals AWBURST[0] High.</p> |

| Field Name | Bits | Type | Reset Value | Description |
|----------------|-------|---------------------------|-------------------------------|--|
| src_cache_ctrl | 13:11 | sro,ns sraz,n snsro | 0x0 | Programs the AXI ARCACHE signals that are used for DMA reads of the source data (0: Low, 1: High): Bit [13] programs ARCACHE[2] Bit [12] programs ARCACHE[1] Bit [11] programs ARCACHE[0] Note: The DMAC ties ARCACHE[3] Low. Setting ARCACHE[2:1]= b10 violates the AXI protocol. |
| src_prot_ctrl | 10:8 | sro,ns sraz,n snsro | dmac0_ns: 0x0 dmac0_s: 0x2 | Programs the AXI ARPROT signals that are used for DMA reads of the source data (0: Low, 1: High): Bit [10] programs ARPROT[2] Bit [9] programs ARPROT[1] Bit [8] programs ARPROT[0] Note: Only DMA channels in the Secure state can program ARPROT[1] Low, that is, a secure access. If a DMA channel in the Non-secure state attempts to set ARPROT[1] Low, the DMA channel aborts. |
| src_burst_len | 7:4 | sro,ns sraz,n snsro | 0x0 | For each burst, these bits program the number of data transfers that the DMAC performs when it reads the source data: 0000: 1 data transfer 0001: 2 data transfers ... 1111: 16 data transfers. The total number of bytes that the DMAC reads into the MFIFO when it executes a DMALD instruction is the product of src_burst_len and src_burst_size. Note: These bits control the state of ARLEN[3:0]. |
| src_burst_size | 3:1 | sro,ns sraz,n snsro | 0x0 | For each beat within a burst, it programs the number of bytes that the DMAC reads from the source: 000: reads 1 byte per beat 001: reads 2 bytes per beat 010: reads 4 bytes per beat 011: reads 8 bytes per beat 100: reads 16 bytes per beat 101 to 111: reserved. The total number of bytes that the DMAC reads into the MFIFO when it executes a DMALD instruction is the product of src_burst_len and src_burst_size. Note: These bits control the state of ARSIZE[2:0]. |
| src_inc | 0 | sro,ns sraz,n snsro | 0x0 | Programs the burst type that the DMAC performs when it reads the source data: 0: Fixed-address burst, DMAC signal ARBURST[0] driven Low. 1: Incrementing-address burst, DMAC signal ARBURST[0] driven High. |

Register ([dmac](#)) XDmaPs_LC0_n_OFFSET_1

| | |
|------------------|---|
| Name | XDmaPs_LC0_n_OFFSET_1 |
| Relative Address | 0x0000042C |
| Absolute Address | dmac0_ns: 0xF800442C dmac0_s: 0xF800342C |
| Width | 32 bits |
| Access Type | mixed |
| Reset Value | 0x00000000 |
| Description | Loop Counter 0 DMA Channel 1 |

Register XDmaPs_LC0_n_OFFSET_1 Details

| Field Name | Bits | Type | Reset Value | Description |
|------------------------|------|---------------------------|-------------|--|
| reserved | 31:8 | rud | 0x0 | reserved, read undefined |
| loop_counter_iteration | 7:0 | sro,ns sraz,n snsro | 0x0 | Provides the status of loop counter zero for the DMA channel thread. The DMAC updates this register when it executes DMALPEND[S]B], and the DMA channel thread is programmed to use loop counter zero. |

Register ([dmac](#)) XDmaPs_LC1_n_OFFSET_1

| | |
|------------------|---|
| Name | XDmaPs_LC1_n_OFFSET_1 |
| Relative Address | 0x00000430 |
| Absolute Address | dmac0_ns: 0xF8004430 dmac0_s: 0xF8003430 |
| Width | 32 bits |
| Access Type | mixed |
| Reset Value | 0x00000000 |
| Description | Loop Counter 1 DMA Channel 1 |

Register XDmaPs_LC1_n_OFFSET_1 Details

| Field Name | Bits | Type | Reset Value | Description |
|------------------------|------|---------------------------|-------------|--|
| reserved | 31:8 | rud | 0x0 | reserved, read undefined |
| loop_counter_iteration | 7:0 | sro,ns sraz,n snsro | 0x0 | Provides the status of loop counter one for the DMA channel thread. The DMAC updates this register when it executes DMALPEND[S]B], and the DMA channel thread is programmed to use loop counter one. |

Register ([dmac](#)) XDmaPs_SA_n_OFFSET_2

| | |
|------------------|---|
| Name | XDmaPs_SA_n_OFFSET_2 |
| Relative Address | 0x00000440 |
| Absolute Address | dmac0_ns: 0xF8004440 dmac0_s: 0xF8003440 |
| Width | 32 bits |
| Access Type | mixed |
| Reset Value | 0x00000000 |
| Description | Source Address DMA Channel 2 |

Register XDmaPs_SA_n_OFFSET_2 Details

| Field Name | Bits | Type | Reset Value | Description |
|------------|------|---------------------------|-------------|---|
| src_addr | 31:0 | sro,ns sraz,n snsro | 0x0 | Source data address (physical memory address) for DMA channel thread. |

Register ([dmac](#)) XDmaPs_DA_n_OFFSET_2

| | |
|------------------|---|
| Name | XDmaPs_DA_n_OFFSET_2 |
| Relative Address | 0x00000444 |
| Absolute Address | dmac0_ns: 0xF8004444 dmac0_s: 0xF8003444 |
| Width | 32 bits |
| Access Type | mixed |
| Reset Value | 0x00000000 |
| Description | Destination Addr DMA Channel 2 |

Register XDmaPs_DA_n_OFFSET_2 Details

| Field Name | Bits | Type | Reset Value | Description |
|------------|------|---------------------------|-------------|--|
| dest_addr | 31:0 | sro,ns sraz,n snsro | 0x0 | Destination data address (physical memory address) for DMA channel thread. |

Register ([dmac](#)) XDmaPs_CC_n_OFFSET_2

| | |
|------------------|----------------------|
| Name | XDmaPs_CC_n_OFFSET_2 |
| Relative Address | 0x00000448 |

Absolute Address dmac0_ns: 0xF8004448
 dmac0_s: 0xF8003448

Width 32 bits

Access Type mixed

Reset Value dmac0_ns: 0x00000000
 dmac0_s: 0x00800200

Description Channel Control DMA Channel 2

Register XDmaPs_CC_n_OFFSET_2 Details

| Field Name | Bits | Type | Reset Value | Description |
|------------------|-------|---------------------------|-------------------------------|--|
| reserved | 31 | rud | 0x0 | reserved, read undefined |
| endian_swap_size | 30:28 | sro,ns sraz,n snsro | 0x0 | Data swap: little-endian and byte-invariant big-endian (BE-8) formats. 000: No swap, 8-bit data 001: Swap bytes within 16-bit data 010: Swap bytes within 32-bit data 011: Swap bytes within 64-bit data 100: Swap bytes within 128-bit data 101 to 111: Reserved |
| dst_cache_ctrl | 27:25 | sro,ns sraz,n snsro | 0x0 | Programs the AXI AWCACHE signals that are used when the DMAC writes to the destination (0: Low, 1: High): Bit [27] programs AWCACHE[3] Hardwired Low to AWCACHE[2] Bit [26] programs AWCACHE[1] Bit [25] programs AWCACHE[0] Note: Setting AWCACHE[3,1]=b10 violates the AXI protocol. |
| dst_prot_ctrl | 24:22 | sro,ns sraz,n snsro | dmac0_ns: 0x0 dmac0_s: 0x2 | Programs the AWPROT signals that are used when the DMAC writes the destination data (0: Low, 1: High): Bit [24] programs AWPROT[2] Bit [23] programs AWPROT[1] Bit [22] programs AWPROT[0] Note: Only DMA channels in the Secure state can program AWPROT[1] Low, that is, a secure access. If a DMA channel in the Non-secure state attempts to set AWPROT[1] Low, then the DMA channel aborts. |

| Field Name | Bits | Type | Reset Value | Description |
|----------------|-------|---------------------------|-------------------------------|--|
| dst_burst_len | 21:18 | sro,ns sraz,n snsro | 0x0 | For each burst, these bits program the number of data transfers that the DMAC performs when it writes the destination data: 0000: 1 data transfer 0001: 2 data transfers 0010: 3 data transfers ... 1111: 16 data transfers. The total number of bytes that the DMAC writes out of the MFIFO when it executes a DMAST instruction is the product of dst_burst_len and dst_burst_size. Note: These bits control the state of AWLEN[3:0]. |
| dst_burst_size | 17:15 | sro,ns sraz,n snsro | 0x0 | For each beat within a burst, it programs the number of bytes that the DMAC writes to the destination: 000: writes 1 byte per beat 001: writes 2 bytes per beat 010: writes 4 bytes per beat 011: writes 8 bytes per beat 100: writes 16 bytes per beat 101 to 111: reserved. The total number of bytes that the DMAC writes out of the MFIFO when it executes a DMAST instruction is the product of dst_burst_len and dst_burst_size. Note: These bits control the state of AWSIZE[2:0]. |
| dst_inc | 14 | sro,ns sraz,n snsro | 0x0 | Programs the burst type that the DMAC performs when it writes the destination data: 0: Fixed-address burst. The DMAC signals AWBURST[0] Low. 1: Incrementing-address burst. The DMAC signals AWBURST[0] High. |
| src_cache_ctrl | 13:11 | sro,ns sraz,n snsro | 0x0 | Programs the AXI ARCACHE signals that are used for DMA reads of the source data (0: Low, 1: High): Bit [13] programs ARCACHE[2] Bit [12] programs ARCACHE[1] Bit [11] programs ARCACHE[0] Note: The DMAC ties ARCACHE[3] Low. Setting ARCACHE[2:1]= b10 violates the AXI protocol. |
| src_prot_ctrl | 10:8 | sro,ns sraz,n snsro | dmac0_ns: 0x0 dmac0_s: 0x2 | Programs the AXI ARPROT signals that are used for DMA reads of the source data (0: Low, 1: High): Bit [10] programs ARPROT[2] Bit [9] programs ARPROT[1] Bit [8] programs ARPROT[0] Note: Only DMA channels in the Secure state can program ARPROT[1] Low, that is, a secure access. If a DMA channel in the Non-secure state attempts to set ARPROT[1] Low, the DMA channel aborts. |

| Field Name | Bits | Type | Reset Value | Description |
|----------------|------|---------------------------|-------------|--|
| src_burst_len | 7:4 | sro,ns sraz,n snsro | 0x0 | For each burst, these bits program the number of data transfers that the DMAC performs when it reads the source data: 0000: 1 data transfer 0001: 2 data transfers ... 1111: 16 data transfers. The total number of bytes that the DMAC reads into the MFIFO when it executes a DMALD instruction is the product of src_burst_len and src_burst_size. Note: These bits control the state of ARLEN[3:0]. |
| src_burst_size | 3:1 | sro,ns sraz,n snsro | 0x0 | For each beat within a burst, it programs the number of bytes that the DMAC reads from the source: 000: reads 1 byte per beat 001: reads 2 bytes per beat 010: reads 4 bytes per beat 011: reads 8 bytes per beat 100: reads 16 bytes per beat 101 to 111: reserved. The total number of bytes that the DMAC reads into the MFIFO when it executes a DMALD instruction is the product of src_burst_len and src_burst_size. Note: These bits control the state of ARSIZE[2:0]. |
| src_inc | 0 | sro,ns sraz,n snsro | 0x0 | Programs the burst type that the DMAC performs when it reads the source data: 0: Fixed-address burst, DMAC signal ARBURST[0] driven Low. 1: Incrementing-address burst, DMAC signal ARBURST[0] driven High. |

Register ([dmac](#)) XDmaPs_LC0_n_OFFSET_2

| | |
|------------------|---|
| Name | XDmaPs_LC0_n_OFFSET_2 |
| Relative Address | 0x0000044C |
| Absolute Address | dmac0_ns: 0xF800444C dmac0_s: 0xF800344C |
| Width | 32 bits |
| Access Type | mixed |
| Reset Value | 0x00000000 |
| Description | Loop Counter 0 DMA Channel 2 |

Register XDmaPs_LC0_n_OFFSET_2 Details

| Field Name | Bits | Type | Reset Value | Description |
|------------------------|------|---------------------------|-------------|--|
| reserved | 31:8 | rud | 0x0 | reserved, read undefined |
| loop_counter_iteration | 7:0 | sro,ns sraz,n snsro | 0x0 | Provides the status of loop counter zero for the DMA channel thread. The DMAC updates this register when it executes DMALPEND[S]B], and the DMA channel thread is programmed to use loop counter zero. |

Register ([dmac](#)) XDmaPs_LC1_n_OFFSET_2

| | |
|------------------|---|
| Name | XDmaPs_LC1_n_OFFSET_2 |
| Relative Address | 0x00000450 |
| Absolute Address | dmac0_ns: 0xF8004450 dmac0_s: 0xF8003450 |
| Width | 32 bits |
| Access Type | mixed |
| Reset Value | 0x00000000 |
| Description | Loop Counter 1 DMA Channel 2 |

Register XDmaPs_LC1_n_OFFSET_2 Details

| Field Name | Bits | Type | Reset Value | Description |
|------------------------|------|---------------------------|-------------|--|
| reserved | 31:8 | rud | 0x0 | reserved, read undefined |
| loop_counter_iteration | 7:0 | sro,ns sraz,n snsro | 0x0 | Provides the status of loop counter one for the DMA channel thread. The DMAC updates this register when it executes DMALPEND[S]B], and the DMA channel thread is programmed to use loop counter one. |

Register ([dmac](#)) XDmaPs_SA_n_OFFSET_3

| | |
|------------------|---|
| Name | XDmaPs_SA_n_OFFSET_3 |
| Relative Address | 0x00000460 |
| Absolute Address | dmac0_ns: 0xF8004460 dmac0_s: 0xF8003460 |
| Width | 32 bits |
| Access Type | mixed |
| Reset Value | 0x00000000 |
| Description | Source Address DMA Channel 3 |

Register XDmaPs_SA_n_OFFSET_3 Details

| Field Name | Bits | Type | Reset Value | Description |
|------------|------|---------------------------|-------------|---|
| src_addr | 31:0 | sro,ns sraz,n snsro | 0x0 | Source data address (physical memory address) for DMA channel thread. |

Register ([dmac](#)) XDmaPs_DA_n_OFFSET_3

| | |
|------------------|---|
| Name | XDmaPs_DA_n_OFFSET_3 |
| Relative Address | 0x00000464 |
| Absolute Address | dmac0_ns: 0xF8004464 dmac0_s: 0xF8003464 |
| Width | 32 bits |
| Access Type | mixed |
| Reset Value | 0x00000000 |
| Description | Destination Addr DMA Channel 3 |

Register XDmaPs_DA_n_OFFSET_3 Details

| Field Name | Bits | Type | Reset Value | Description |
|------------|------|---------------------------|-------------|--|
| dest_addr | 31:0 | sro,ns sraz,n snsro | 0x0 | Destination data address (physical memory address) for DMA channel thread. |

Register ([dmac](#)) XDmaPs_CC_n_OFFSET_3

| | |
|------------------|---|
| Name | XDmaPs_CC_n_OFFSET_3 |
| Relative Address | 0x00000468 |
| Absolute Address | dmac0_ns: 0xF8004468 dmac0_s: 0xF8003468 |
| Width | 32 bits |
| Access Type | mixed |
| Reset Value | dmac0_ns: 0x00000000 dmac0_s: 0x00800200 |
| Description | Channel Control DMA Channel 3 |

Register XDmaPs_CC_n_OFFSET_3 Details

| Field Name | Bits | Type | Reset Value | Description |
|------------------|-------|---------------------------|-------------------------------|--|
| reserved | 31 | rud | 0x0 | reserved, read undefined |
| endian_swap_size | 30:28 | sro,ns sraz,n snsro | 0x0 | Data swap: little-endian and byte-invariant big-endian (BE-8) formats. 000: No swap, 8-bit data 001: Swap bytes within 16-bit data 010: Swap bytes within 32-bit data 011: Swap bytes within 64-bit data 100: Swap bytes within 128-bit data 101 to 111: Reserved |
| dst_cache_ctrl | 27:25 | sro,ns sraz,n snsro | 0x0 | Programs the AXI AWCACHE signals that are used when the DMAC writes to the destination (0: Low, 1: High): Bit [27] programs AWCACHE[3] Hardwired Low to AWCACHE[2] Bit [26] programs AWCACHE[1] Bit [25] programs AWCACHE[0] Note: Setting AWCACHE[3,1]=b10 violates the AXI protocol. |
| dst_prot_ctrl | 24:22 | sro,ns sraz,n snsro | dmac0_ns: 0x0 dmac0_s: 0x2 | Programs the AWPROT signals that are used when the DMAC writes the destination data (0: Low, 1: High): Bit [24] programs AWPROT[2] Bit [23] programs AWPROT[1] Bit [22] programs AWPROT[0] Note: Only DMA channels in the Secure state can program AWPROT[1] Low, that is, a secure access. If a DMA channel in the Non-secure state attempts to set AWPROT[1] Low, then the DMA channel aborts. |
| dst_burst_len | 21:18 | sro,ns sraz,n snsro | 0x0 | For each burst, these bits program the number of data transfers that the DMAC performs when it writes the destination data: 0000: 1 data transfer 0001: 2 data transfers 0010: 3 data transfers ... 1111: 16 data transfers. The total number of bytes that the DMAC writes out of the MFIFO when it executes a DMAST instruction is the product of dst_burst_len and dst_burst_size. Note: These bits control the state of AWLEN[3:0]. |

| Field Name | Bits | Type | Reset Value | Description |
|----------------|-------|---------------------------|-------------------------------|--|
| dst_burst_size | 17:15 | sro,ns sraz,n snsro | 0x0 | For each beat within a burst, it programs the number of bytes that the DMAC writes to the destination: 000: writes 1 byte per beat 001: writes 2 bytes per beat 010: writes 4 bytes per beat 011: writes 8 bytes per beat 100: writes 16 bytes per beat 101 to 111: reserved. The total number of bytes that the DMAC writes out of the MFIFO when it executes a DMAST instruction is the product of dst_burst_len and dst_burst_size. Note: These bits control the state of AWSIZE[2:0]. |
| dst_inc | 14 | sro,ns sraz,n snsro | 0x0 | Programs the burst type that the DMAC performs when it writes the destination data: 0: Fixed-address burst. The DMAC signals AWBURST[0] Low. 1: Incrementing-address burst. The DMAC signals AWBURST[0] High. |
| src_cache_ctrl | 13:11 | sro,ns sraz,n snsro | 0x0 | Programs the AXI ARCACHE signals that are used for DMA reads of the source data (0: Low, 1: High): Bit [13] programs ARCACHE[2] Bit [12] programs ARCACHE[1] Bit [11] programs ARCACHE[0] Note: The DMAC ties ARCACHE[3] Low. Setting ARCACHE[2:1]= b10 violates the AXI protocol. |
| src_prot_ctrl | 10:8 | sro,ns sraz,n snsro | dmac0_ns: 0x0 dmac0_s: 0x2 | Programs the AXI ARPROT signals that are used for DMA reads of the source data (0: Low, 1: High): Bit [10] programs ARPROT[2] Bit [9] programs ARPROT[1] Bit [8] programs ARPROT[0] Note: Only DMA channels in the Secure state can program ARPROT[1] Low, that is, a secure access. If a DMA channel in the Non-secure state attempts to set ARPROT[1] Low, the DMA channel aborts. |
| src_burst_len | 7:4 | sro,ns sraz,n snsro | 0x0 | For each burst, these bits program the number of data transfers that the DMAC performs when it reads the source data: 0000: 1 data transfer 0001: 2 data transfers ... 1111: 16 data transfers. The total number of bytes that the DMAC reads into the MFIFO when it executes a DMALD instruction is the product of src_burst_len and src_burst_size. Note: These bits control the state of ARLEN[3:0]. |

| Field Name | Bits | Type | Reset Value | Description |
|----------------|------|---------------------------|-------------|--|
| src_burst_size | 3:1 | sro,ns sraz,n snsro | 0x0 | For each beat within a burst, it programs the number of bytes that the DMAC reads from the source: 000: reads 1 byte per beat 001: reads 2 bytes per beat 010: reads 4 bytes per beat 011: reads 8 bytes per beat 100: reads 16 bytes per beat 101 to 111: reserved. The total number of bytes that the DMAC reads into the MFIFO when it executes a DMALD instruction is the product of src_burst_len and src_burst_size. Note: These bits control the state of ARSIZE[2:0]. |
| src_inc | 0 | sro,ns sraz,n snsro | 0x0 | Programs the burst type that the DMAC performs when it reads the source data: 0: Fixed-address burst, DMAC signal ARBURST[0] driven Low. 1: Incrementing-address burst, DMAC signal ARBURST[0] driven High. |

Register ([dmac](#)) XDmaPs_LC0_n_OFFSET_3

| | |
|------------------|---|
| Name | XDmaPs_LC0_n_OFFSET_3 |
| Relative Address | 0x0000046C |
| Absolute Address | dmac0_ns: 0xF800446C dmac0_s: 0xF800346C |
| Width | 32 bits |
| Access Type | mixed |
| Reset Value | 0x00000000 |
| Description | Loop Counter 0 DMA Channel 3 |

Register XDmaPs_LC0_n_OFFSET_3 Details

| Field Name | Bits | Type | Reset Value | Description |
|------------------------|------|---------------------------|-------------|---|
| reserved | 31:8 | rud | 0x0 | reserved, read undefined |
| loop_counter_iteration | 7:0 | sro,ns sraz,n snsro | 0x0 | Provides the status of loop counter zero for the DMA channel thread. The DMAC updates this register when it executes DMALPEND[S][B], and the DMA channel thread is programmed to use loop counter zero. |

Register ([dmac](#)) XDmaPs_LC1_n_OFFSET_3

| | |
|------------------|---|
| Name | XDmaPs_LC1_n_OFFSET_3 |
| Relative Address | 0x00000470 |
| Absolute Address | dmac0_ns: 0xF8004470 dmac0_s: 0xF8003470 |
| Width | 32 bits |
| Access Type | mixed |
| Reset Value | 0x00000000 |
| Description | Loop Counter 1 DMA Channel 3 |

Register XDmaPs_LC1_n_OFFSET_3 Details

| Field Name | Bits | Type | Reset Value | Description |
|------------------------|------|---------------------------|-------------|--|
| reserved | 31:8 | rud | 0x0 | reserved, read undefined |
| loop_counter_iteration | 7:0 | sro,ns sraz,n snsro | 0x0 | Provides the status of loop counter one for the DMA channel thread. The DMAC updates this register when it executes DMALPEND[S]B], and the DMA channel thread is programmed to use loop counter one. |

Register ([dmac](#)) XDmaPs_SA_n_OFFSET_4

| | |
|------------------|---|
| Name | XDmaPs_SA_n_OFFSET_4 |
| Relative Address | 0x00000480 |
| Absolute Address | dmac0_ns: 0xF8004480 dmac0_s: 0xF8003480 |
| Width | 32 bits |
| Access Type | mixed |
| Reset Value | 0x00000000 |
| Description | Source Address DMA Channel 4 |

Register XDmaPs_SA_n_OFFSET_4 Details

| Field Name | Bits | Type | Reset Value | Description |
|------------|------|---------------------------|-------------|---|
| src_addr | 31:0 | sro,ns sraz,n snsro | 0x0 | Source data address (physical memory address) for DMA channel thread. |

Register ([dmac](#)) XDmaPs_DA_n_OFFSET_4

| | |
|------------------|---|
| Name | XDmaPs_DA_n_OFFSET_4 |
| Relative Address | 0x00000484 |
| Absolute Address | dmac0_ns: 0xF8004484 dmac0_s: 0xF8003484 |
| Width | 32 bits |
| Access Type | mixed |
| Reset Value | 0x00000000 |
| Description | Destination Addr DMA Channel 4 |

Register XDmaPs_DA_n_OFFSET_4 Details

| Field Name | Bits | Type | Reset Value | Description |
|------------|------|---------------------------|-------------|--|
| dest_addr | 31:0 | sro,ns sraz,n snsro | 0x0 | Destination data address (physical memory address) for DMA channel thread. |

Register ([dmac](#)) XDmaPs_CC_n_OFFSET_4

| | |
|------------------|---|
| Name | XDmaPs_CC_n_OFFSET_4 |
| Relative Address | 0x00000488 |
| Absolute Address | dmac0_ns: 0xF8004488 dmac0_s: 0xF8003488 |
| Width | 32 bits |
| Access Type | mixed |
| Reset Value | dmac0_ns: 0x00000000 dmac0_s: 0x00800200 |
| Description | Channel Control DMA Channel 4 |

Register XDmaPs_CC_n_OFFSET_4 Details

| Field Name | Bits | Type | Reset Value | Description |
|------------------|-------|---------------------------|-------------|---|
| reserved | 31 | rud | 0x0 | reserved, read undefined |
| endian_swap_size | 30:28 | sro,ns sraz,n snsro | 0x0 | Data swap: little-endian and byte-invariant big-endian (BE-8) formats. 000: No swap, 8-bit data 001: Swap bytes within 16-bit data 010: Swap bytes within 32-bit data 011: Swap bytes within 64-bit data 100: Swap bytes within 128-bit data 101 to 111: Reserved |

| Field Name | Bits | Type | Reset Value | Description |
|----------------|-------|---------------------------|-------------------------------|--|
| dst_cache_ctrl | 27:25 | sro,ns sraz,n snsro | 0x0 | <p>Programs the AXI AWCACHE signals that are used when the DMAC writes to the destination (0: Low, 1: High):</p> <p>Bit [27] programs AWCACHE[3] Hardwired Low to AWCACHE[2] Bit [26] programs AWCACHE[1] Bit [25] programs AWCACHE[0] Note: Setting AWCACHE[3,1]=b10 violates the AXI protocol.</p> |
| dst_prot_ctrl | 24:22 | sro,ns sraz,n snsro | dmac0_ns: 0x0 dmac0_s: 0x2 | <p>Programs the AWPROT signals that are used when the DMAC writes the destination data (0: Low, 1: High):</p> <p>Bit [24] programs AWPROT[2] Bit [23] programs AWPROT[1] Bit [22] programs AWPROT[0] Note: Only DMA channels in the Secure state can program AWPROT[1] Low, that is, a secure access. If a DMA channel in the Non-secure state attempts to set AWPROT[1] Low, then the DMA channel aborts.</p> |
| dst_burst_len | 21:18 | sro,ns sraz,n snsro | 0x0 | <p>For each burst, these bits program the number of data transfers that the DMAC performs when it writes the destination data:</p> <p>0000: 1 data transfer 0001: 2 data transfers 0010: 3 data transfers ... 1111: 16 data transfers.</p> <p>The total number of bytes that the DMAC writes out of the MFIFO when it executes a DMAST instruction is the product of dst_burst_len and dst_burst_size. Note: These bits control the state of AWLEN[3:0].</p> |
| dst_burst_size | 17:15 | sro,ns sraz,n snsro | 0x0 | <p>For each beat within a burst, it programs the number of bytes that the DMAC writes to the destination:</p> <p>000: writes 1 byte per beat 001: writes 2 bytes per beat 010: writes 4 bytes per beat 011: writes 8 bytes per beat 100: writes 16 bytes per beat 101 to 111: reserved.</p> <p>The total number of bytes that the DMAC writes out of the MFIFO when it executes a DMAST instruction is the product of dst_burst_len and dst_burst_size. Note: These bits control the state of AWSIZE[2:0].</p> |

| Field Name | Bits | Type | Reset Value | Description |
|----------------|-------|---------------------------|-------------------------------|--|
| dst_inc | 14 | sro,ns sraz,n snsro | 0x0 | Programs the burst type that the DMAC performs when it writes the destination data: 0: Fixed-address burst. The DMAC signals AWBURST[0] Low. 1: Incrementing-address burst. The DMAC signals AWBURST[0] High. |
| src_cache_ctrl | 13:11 | sro,ns sraz,n snsro | 0x0 | Programs the AXI ARCACHE signals that are used for DMA reads of the source data (0: Low, 1: High): Bit [13] programs ARCACHE[2] Bit [12] programs ARCACHE[1] Bit [11] programs ARCACHE[0] Note: The DMAC ties ARCACHE[3] Low. Setting ARCACHE[2:1]= b10 violates the AXI protocol. |
| src_prot_ctrl | 10:8 | sro,ns sraz,n snsro | dmac0_ns: 0x0 dmac0_s: 0x2 | Programs the AXI ARPROT signals that are used for DMA reads of the source data (0: Low, 1: High): Bit [10] programs ARPROT[2] Bit [9] programs ARPROT[1] Bit [8] programs ARPROT[0] Note: Only DMA channels in the Secure state can program ARPROT[1] Low, that is, a secure access. If a DMA channel in the Non-secure state attempts to set ARPROT[1] Low, the DMA channel aborts. |
| src_burst_len | 7:4 | sro,ns sraz,n snsro | 0x0 | For each burst, these bits program the number of data transfers that the DMAC performs when it reads the source data: 0000: 1 data transfer 0001: 2 data transfers ... 1111: 16 data transfers. The total number of bytes that the DMAC reads into the MFIFO when it executes a DMALD instruction is the product of src_burst_len and src_burst_size. Note: These bits control the state of ARLEN[3:0]. |

| Field Name | Bits | Type | Reset Value | Description |
|----------------|------|---------------------------|-------------|--|
| src_burst_size | 3:1 | sro,ns sraz,n snsro | 0x0 | For each beat within a burst, it programs the number of bytes that the DMAC reads from the source: 000: reads 1 byte per beat 001: reads 2 bytes per beat 010: reads 4 bytes per beat 011: reads 8 bytes per beat 100: reads 16 bytes per beat 101 to 111: reserved. The total number of bytes that the DMAC reads into the MFIFO when it executes a DMALD instruction is the product of src_burst_len and src_burst_size. Note: These bits control the state of ARSIZE[2:0]. |
| src_inc | 0 | sro,ns sraz,n snsro | 0x0 | Programs the burst type that the DMAC performs when it reads the source data: 0: Fixed-address burst, DMAC signal ARBURST[0] driven Low. 1: Incrementing-address burst, DMAC signal ARBURST[0] driven High. |

Register ([dmac](#)) XDmaPs_LC0_n_OFFSET_4

| | |
|------------------|---|
| Name | XDmaPs_LC0_n_OFFSET_4 |
| Relative Address | 0x0000048C |
| Absolute Address | dmac0_ns: 0xF800448C dmac0_s: 0xF800348C |
| Width | 32 bits |
| Access Type | mixed |
| Reset Value | 0x00000000 |
| Description | Loop Counter 0 DMA Channel 4 |

Register XDmaPs_LC0_n_OFFSET_4 Details

| Field Name | Bits | Type | Reset Value | Description |
|------------------------|------|---------------------------|-------------|---|
| reserved | 31:8 | rud | 0x0 | reserved, read undefined |
| loop_counter_iteration | 7:0 | sro,ns sraz,n snsro | 0x0 | Provides the status of loop counter zero for the DMA channel thread. The DMAC updates this register when it executes DMALPEND[S][B], and the DMA channel thread is programmed to use loop counter zero. |

Register ([dmac](#)) XDmaPs_LC1_n_OFFSET_4

| | |
|------------------|---|
| Name | XDmaPs_LC1_n_OFFSET_4 |
| Relative Address | 0x00000490 |
| Absolute Address | dmac0_ns: 0xF8004490 dmac0_s: 0xF8003490 |
| Width | 32 bits |
| Access Type | mixed |
| Reset Value | 0x00000000 |
| Description | Loop Counter 1 DMA Channel 4 |

Register XDmaPs_LC1_n_OFFSET_4 Details

| Field Name | Bits | Type | Reset Value | Description |
|------------------------|------|---------------------------|-------------|--|
| reserved | 31:8 | rud | 0x0 | reserved, read undefined |
| loop_counter_iteration | 7:0 | sro,ns sraz,n snsro | 0x0 | Provides the status of loop counter one for the DMA channel thread. The DMAC updates this register when it executes DMALPEND[S]B], and the DMA channel thread is programmed to use loop counter one. |

Register ([dmac](#)) XDmaPs_SA_n_OFFSET_5

| | |
|------------------|---|
| Name | XDmaPs_SA_n_OFFSET_5 |
| Relative Address | 0x000004A0 |
| Absolute Address | dmac0_ns: 0xF80044A0 dmac0_s: 0xF80034A0 |
| Width | 32 bits |
| Access Type | mixed |
| Reset Value | 0x00000000 |
| Description | Source Address DMA Channel 5 |

Register XDmaPs_SA_n_OFFSET_5 Details

| Field Name | Bits | Type | Reset Value | Description |
|------------|------|---------------------------|-------------|---|
| src_addr | 31:0 | sro,ns sraz,n snsro | 0x0 | Source data address (physical memory address) for DMA channel thread. |

Register ([dmac](#)) XDmaPs_DA_n_OFFSET_5

| | |
|------------------|---|
| Name | XDmaPs_DA_n_OFFSET_5 |
| Relative Address | 0x000004A4 |
| Absolute Address | dmac0_ns: 0xF80044A4 dmac0_s: 0xF80034A4 |
| Width | 32 bits |
| Access Type | mixed |
| Reset Value | 0x00000000 |
| Description | Destination Addr DMA Channel 5 |

Register XDmaPs_DA_n_OFFSET_5 Details

| Field Name | Bits | Type | Reset Value | Description |
|------------|------|---------------------------|-------------|--|
| dest_addr | 31:0 | sro,ns sraz,n snsro | 0x0 | Destination data address (physical memory address) for DMA channel thread. |

Register ([dmac](#)) XDmaPs_CC_n_OFFSET_5

| | |
|------------------|---|
| Name | XDmaPs_CC_n_OFFSET_5 |
| Relative Address | 0x000004A8 |
| Absolute Address | dmac0_ns: 0xF80044A8 dmac0_s: 0xF80034A8 |
| Width | 32 bits |
| Access Type | mixed |
| Reset Value | dmac0_ns: 0x00000000 dmac0_s: 0x00800200 |
| Description | Channel Control DMA Channel 5 |

Register XDmaPs_CC_n_OFFSET_5 Details

| Field Name | Bits | Type | Reset Value | Description |
|------------------|-------|---------------------------|-------------|---|
| reserved | 31 | rud | 0x0 | reserved, read undefined |
| endian_swap_size | 30:28 | sro,ns sraz,n snsro | 0x0 | Data swap: little-endian and byte-invariant big-endian (BE-8) formats. 000: No swap, 8-bit data 001: Swap bytes within 16-bit data 010: Swap bytes within 32-bit data 011: Swap bytes within 64-bit data 100: Swap bytes within 128-bit data 101 to 111: Reserved |

| Field Name | Bits | Type | Reset Value | Description |
|----------------|-------|---------------------------|-------------------------------|--|
| dst_cache_ctrl | 27:25 | sro,ns sraz,n snsro | 0x0 | <p>Programs the AXI AWCACHE signals that are used when the DMAC writes to the destination (0: Low, 1: High):</p> <p>Bit [27] programs AWCACHE[3] Hardwired Low to AWCACHE[2] Bit [26] programs AWCACHE[1] Bit [25] programs AWCACHE[0] Note: Setting AWCACHE[3,1]=b10 violates the AXI protocol.</p> |
| dst_prot_ctrl | 24:22 | sro,ns sraz,n snsro | dmac0_ns: 0x0 dmac0_s: 0x2 | <p>Programs the AWPROT signals that are used when the DMAC writes the destination data (0: Low, 1: High):</p> <p>Bit [24] programs AWPROT[2] Bit [23] programs AWPROT[1] Bit [22] programs AWPROT[0] Note: Only DMA channels in the Secure state can program AWPROT[1] Low, that is, a secure access. If a DMA channel in the Non-secure state attempts to set AWPROT[1] Low, then the DMA channel aborts.</p> |
| dst_burst_len | 21:18 | sro,ns sraz,n snsro | 0x0 | <p>For each burst, these bits program the number of data transfers that the DMAC performs when it writes the destination data:</p> <p>0000: 1 data transfer 0001: 2 data transfers 0010: 3 data transfers ... 1111: 16 data transfers.</p> <p>The total number of bytes that the DMAC writes out of the MFIFO when it executes a DMAST instruction is the product of dst_burst_len and dst_burst_size. Note: These bits control the state of AWLEN[3:0].</p> |
| dst_burst_size | 17:15 | sro,ns sraz,n snsro | 0x0 | <p>For each beat within a burst, it programs the number of bytes that the DMAC writes to the destination:</p> <p>000: writes 1 byte per beat 001: writes 2 bytes per beat 010: writes 4 bytes per beat 011: writes 8 bytes per beat 100: writes 16 bytes per beat 101 to 111: reserved.</p> <p>The total number of bytes that the DMAC writes out of the MFIFO when it executes a DMAST instruction is the product of dst_burst_len and dst_burst_size. Note: These bits control the state of AWSIZE[2:0].</p> |

| Field Name | Bits | Type | Reset Value | Description |
|----------------|-------|---------------------------|-------------------------------|--|
| dst_inc | 14 | sro,ns sraz,n snsro | 0x0 | Programs the burst type that the DMAC performs when it writes the destination data: 0: Fixed-address burst. The DMAC signals AWBURST[0] Low. 1: Incrementing-address burst. The DMAC signals AWBURST[0] High. |
| src_cache_ctrl | 13:11 | sro,ns sraz,n snsro | 0x0 | Programs the AXI ARCACHE signals that are used for DMA reads of the source data (0: Low, 1: High): Bit [13] programs ARCACHE[2] Bit [12] programs ARCACHE[1] Bit [11] programs ARCACHE[0] Note: The DMAC ties ARCACHE[3] Low. Setting ARCACHE[2:1]= b10 violates the AXI protocol. |
| src_prot_ctrl | 10:8 | sro,ns sraz,n snsro | dmac0_ns: 0x0 dmac0_s: 0x2 | Programs the AXI ARPROT signals that are used for DMA reads of the source data (0: Low, 1: High): Bit [10] programs ARPROT[2] Bit [9] programs ARPROT[1] Bit [8] programs ARPROT[0] Note: Only DMA channels in the Secure state can program ARPROT[1] Low, that is, a secure access. If a DMA channel in the Non-secure state attempts to set ARPROT[1] Low, the DMA channel aborts. |
| src_burst_len | 7:4 | sro,ns sraz,n snsro | 0x0 | For each burst, these bits program the number of data transfers that the DMAC performs when it reads the source data: 0000: 1 data transfer 0001: 2 data transfers ... 1111: 16 data transfers. The total number of bytes that the DMAC reads into the MFIFO when it executes a DMALD instruction is the product of src_burst_len and src_burst_size. Note: These bits control the state of ARLEN[3:0]. |

| Field Name | Bits | Type | Reset Value | Description |
|----------------|------|---------------------------|-------------|--|
| src_burst_size | 3:1 | sro,ns sraz,n snsro | 0x0 | For each beat within a burst, it programs the number of bytes that the DMAC reads from the source: 000: reads 1 byte per beat 001: reads 2 bytes per beat 010: reads 4 bytes per beat 011: reads 8 bytes per beat 100: reads 16 bytes per beat 101 to 111: reserved. The total number of bytes that the DMAC reads into the MFIFO when it executes a DMALD instruction is the product of src_burst_len and src_burst_size. Note: These bits control the state of ARSIZE[2:0]. |
| src_inc | 0 | sro,ns sraz,n snsro | 0x0 | Programs the burst type that the DMAC performs when it reads the source data: 0: Fixed-address burst, DMAC signal ARBURST[0] driven Low. 1: Incrementing-address burst, DMAC signal ARBURST[0] driven High. |

Register ([dmac](#)) XDmaPs_LC0_n_OFFSET_5

| | |
|------------------|---|
| Name | XDmaPs_LC0_n_OFFSET_5 |
| Relative Address | 0x000004AC |
| Absolute Address | dmac0_ns: 0xF80044AC dmac0_s: 0xF80034AC |
| Width | 32 bits |
| Access Type | mixed |
| Reset Value | 0x00000000 |
| Description | Loop Counter 0 DMA Channel 5 |

Register XDmaPs_LC0_n_OFFSET_5 Details

| Field Name | Bits | Type | Reset Value | Description |
|------------------------|------|---------------------------|-------------|---|
| reserved | 31:8 | rud | 0x0 | reserved, read undefined |
| loop_counter_iteration | 7:0 | sro,ns sraz,n snsro | 0x0 | Provides the status of loop counter zero for the DMA channel thread. The DMAC updates this register when it executes DMALPEND[S][B], and the DMA channel thread is programmed to use loop counter zero. |

Register ([dmac](#)) XDmaPs_LC1_n_OFFSET_5

| | |
|------------------|---|
| Name | XDmaPs_LC1_n_OFFSET_5 |
| Relative Address | 0x000004B0 |
| Absolute Address | dmac0_ns: 0xF80044B0 dmac0_s: 0xF80034B0 |
| Width | 32 bits |
| Access Type | mixed |
| Reset Value | 0x00000000 |
| Description | Loop Counter 1 DMA Channel 5 |

Register XDmaPs_LC1_n_OFFSET_5 Details

| Field Name | Bits | Type | Reset Value | Description |
|------------------------|------|---------------------------|-------------|--|
| reserved | 31:8 | rud | 0x0 | reserved, read undefined |
| loop_counter_iteration | 7:0 | sro,ns sraz,n snsro | 0x0 | Provides the status of loop counter one for the DMA channel thread. The DMAC updates this register when it executes DMALPEND[S]B], and the DMA channel thread is programmed to use loop counter one. |

Register ([dmac](#)) XDmaPs_SA_n_OFFSET_6

| | |
|------------------|---|
| Name | XDmaPs_SA_n_OFFSET_6 |
| Relative Address | 0x000004C0 |
| Absolute Address | dmac0_ns: 0xF80044C0 dmac0_s: 0xF80034C0 |
| Width | 32 bits |
| Access Type | mixed |
| Reset Value | 0x00000000 |
| Description | Source Address DMA Channel 6 |

Register XDmaPs_SA_n_OFFSET_6 Details

| Field Name | Bits | Type | Reset Value | Description |
|------------|------|---------------------------|-------------|---|
| src_addr | 31:0 | sro,ns sraz,n snsro | 0x0 | Source data address (physical memory address) for DMA channel thread. |

Register ([dmac](#)) XDmaPs_DA_n_OFFSET_6

| | |
|------------------|---|
| Name | XDmaPs_DA_n_OFFSET_6 |
| Relative Address | 0x000004C4 |
| Absolute Address | dmac0_ns: 0xF80044C4 dmac0_s: 0xF80034C4 |
| Width | 32 bits |
| Access Type | mixed |
| Reset Value | 0x00000000 |
| Description | Destination Addr DMA Channel 6 |

Register XDmaPs_DA_n_OFFSET_6 Details

| Field Name | Bits | Type | Reset Value | Description |
|------------|------|---------------------------|-------------|--|
| dest_addr | 31:0 | sro,ns sraz,n snsro | 0x0 | Destination data address (physical memory address) for DMA channel thread. |

Register ([dmac](#)) XDmaPs_CC_n_OFFSET_6

| | |
|------------------|---|
| Name | XDmaPs_CC_n_OFFSET_6 |
| Relative Address | 0x000004C8 |
| Absolute Address | dmac0_ns: 0xF80044C8 dmac0_s: 0xF80034C8 |
| Width | 32 bits |
| Access Type | mixed |
| Reset Value | dmac0_ns: 0x00000000 dmac0_s: 0x00800200 |
| Description | Channel Control DMA Channel 6 |

Register XDmaPs_CC_n_OFFSET_6 Details

| Field Name | Bits | Type | Reset Value | Description |
|------------------|-------|---------------------------|-------------|---|
| reserved | 31 | rud | 0x0 | reserved, read undefined |
| endian_swap_size | 30:28 | sro,ns sraz,n snsro | 0x0 | Data swap: little-endian and byte-invariant big-endian (BE-8) formats. 000: No swap, 8-bit data 001: Swap bytes within 16-bit data 010: Swap bytes within 32-bit data 011: Swap bytes within 64-bit data 100: Swap bytes within 128-bit data 101 to 111: Reserved |

| Field Name | Bits | Type | Reset Value | Description |
|----------------|-------|---------------------------|-------------------------------|--|
| dst_cache_ctrl | 27:25 | sro,ns sraz,n snsro | 0x0 | <p>Programs the AXI AWCACHE signals that are used when the DMAC writes to the destination (0: Low, 1: High):</p> <p>Bit [27] programs AWCACHE[3] Hardwired Low to AWCACHE[2] Bit [26] programs AWCACHE[1] Bit [25] programs AWCACHE[0] Note: Setting AWCACHE[3,1]=b10 violates the AXI protocol.</p> |
| dst_prot_ctrl | 24:22 | sro,ns sraz,n snsro | dmac0_ns: 0x0 dmac0_s: 0x2 | <p>Programs the AWPROT signals that are used when the DMAC writes the destination data (0: Low, 1: High):</p> <p>Bit [24] programs AWPROT[2] Bit [23] programs AWPROT[1] Bit [22] programs AWPROT[0] Note: Only DMA channels in the Secure state can program AWPROT[1] Low, that is, a secure access. If a DMA channel in the Non-secure state attempts to set AWPROT[1] Low, then the DMA channel aborts.</p> |
| dst_burst_len | 21:18 | sro,ns sraz,n snsro | 0x0 | <p>For each burst, these bits program the number of data transfers that the DMAC performs when it writes the destination data:</p> <p>0000: 1 data transfer 0001: 2 data transfers 0010: 3 data transfers ... 1111: 16 data transfers.</p> <p>The total number of bytes that the DMAC writes out of the MFIFO when it executes a DMAST instruction is the product of dst_burst_len and dst_burst_size. Note: These bits control the state of AWLEN[3:0].</p> |
| dst_burst_size | 17:15 | sro,ns sraz,n snsro | 0x0 | <p>For each beat within a burst, it programs the number of bytes that the DMAC writes to the destination:</p> <p>000: writes 1 byte per beat 001: writes 2 bytes per beat 010: writes 4 bytes per beat 011: writes 8 bytes per beat 100: writes 16 bytes per beat 101 to 111: reserved.</p> <p>The total number of bytes that the DMAC writes out of the MFIFO when it executes a DMAST instruction is the product of dst_burst_len and dst_burst_size. Note: These bits control the state of AWSIZE[2:0].</p> |

| Field Name | Bits | Type | Reset Value | Description |
|----------------|-------|---------------------------|-------------------------------|--|
| dst_inc | 14 | sro,ns sraz,n snsro | 0x0 | Programs the burst type that the DMAC performs when it writes the destination data: 0: Fixed-address burst. The DMAC signals AWBURST[0] Low. 1: Incrementing-address burst. The DMAC signals AWBURST[0] High. |
| src_cache_ctrl | 13:11 | sro,ns sraz,n snsro | 0x0 | Programs the AXI ARCACHE signals that are used for DMA reads of the source data (0: Low, 1: High): Bit [13] programs ARCACHE[2] Bit [12] programs ARCACHE[1] Bit [11] programs ARCACHE[0] Note: The DMAC ties ARCACHE[3] Low. Setting ARCACHE[2:1]= b10 violates the AXI protocol. |
| src_prot_ctrl | 10:8 | sro,ns sraz,n snsro | dmac0_ns: 0x0 dmac0_s: 0x2 | Programs the AXI ARPROT signals that are used for DMA reads of the source data (0: Low, 1: High): Bit [10] programs ARPROT[2] Bit [9] programs ARPROT[1] Bit [8] programs ARPROT[0] Note: Only DMA channels in the Secure state can program ARPROT[1] Low, that is, a secure access. If a DMA channel in the Non-secure state attempts to set ARPROT[1] Low, the DMA channel aborts. |
| src_burst_len | 7:4 | sro,ns sraz,n snsro | 0x0 | For each burst, these bits program the number of data transfers that the DMAC performs when it reads the source data: 0000: 1 data transfer 0001: 2 data transfers ... 1111: 16 data transfers. The total number of bytes that the DMAC reads into the MFIFO when it executes a DMALD instruction is the product of src_burst_len and src_burst_size. Note: These bits control the state of ARLEN[3:0]. |

| Field Name | Bits | Type | Reset Value | Description |
|----------------|------|---------------------------|-------------|--|
| src_burst_size | 3:1 | sro,ns sraz,n snsro | 0x0 | For each beat within a burst, it programs the number of bytes that the DMAC reads from the source: 000: reads 1 byte per beat 001: reads 2 bytes per beat 010: reads 4 bytes per beat 011: reads 8 bytes per beat 100: reads 16 bytes per beat 101 to 111: reserved. The total number of bytes that the DMAC reads into the MFIFO when it executes a DMALD instruction is the product of src_burst_len and src_burst_size. Note: These bits control the state of ARSIZE[2:0]. |
| src_inc | 0 | sro,ns sraz,n snsro | 0x0 | Programs the burst type that the DMAC performs when it reads the source data: 0: Fixed-address burst, DMAC signal ARBURST[0] driven Low. 1: Incrementing-address burst, DMAC signal ARBURST[0] driven High. |

Register ([dmac](#)) XDmaPs_LC0_n_OFFSET_6

| | |
|------------------|---|
| Name | XDmaPs_LC0_n_OFFSET_6 |
| Relative Address | 0x000004CC |
| Absolute Address | dmac0_ns: 0xF80044CC dmac0_s: 0xF80034CC |
| Width | 32 bits |
| Access Type | mixed |
| Reset Value | 0x00000000 |
| Description | Loop Counter 0 DMA Channel 6 |

Register XDmaPs_LC0_n_OFFSET_6 Details

| Field Name | Bits | Type | Reset Value | Description |
|------------------------|------|---------------------------|-------------|---|
| reserved | 31:8 | rud | 0x0 | reserved, read undefined |
| loop_counter_iteration | 7:0 | sro,ns sraz,n snsro | 0x0 | Provides the status of loop counter zero for the DMA channel thread. The DMAC updates this register when it executes DMALPEND[S][B], and the DMA channel thread is programmed to use loop counter zero. |

Register ([dmac](#)) XDmaPs_LC1_n_OFFSET_6

| | |
|------------------|---|
| Name | XDmaPs_LC1_n_OFFSET_6 |
| Relative Address | 0x000004D0 |
| Absolute Address | dmac0_ns: 0xF80044D0 dmac0_s: 0xF80034D0 |
| Width | 32 bits |
| Access Type | mixed |
| Reset Value | 0x00000000 |
| Description | Loop Counter 1 DMA Channel 6 |

Register XDmaPs_LC1_n_OFFSET_6 Details

| Field Name | Bits | Type | Reset Value | Description |
|------------------------|------|---------------------------|-------------|--|
| reserved | 31:8 | rud | 0x0 | reserved, read undefined |
| loop_counter_iteration | 7:0 | sro,ns sraz,n snsro | 0x0 | Provides the status of loop counter one for the DMA channel thread. The DMAC updates this register when it executes DMALPEND[S]B], and the DMA channel thread is programmed to use loop counter one. |

Register ([dmac](#)) XDmaPs_SA_n_OFFSET_7

| | |
|------------------|---|
| Name | XDmaPs_SA_n_OFFSET_7 |
| Relative Address | 0x000004E0 |
| Absolute Address | dmac0_ns: 0xF80044E0 dmac0_s: 0xF80034E0 |
| Width | 32 bits |
| Access Type | mixed |
| Reset Value | 0x00000000 |
| Description | Source Address DMA Channel 7 |

Register XDmaPs_SA_n_OFFSET_7 Details

| Field Name | Bits | Type | Reset Value | Description |
|------------|------|---------------------------|-------------|---|
| src_addr | 31:0 | sro,ns sraz,n snsro | 0x0 | Source data address (physical memory address) for DMA channel thread. |

Register ([dmac](#)) XDmaPs_DA_n_OFFSET_7

| | |
|------------------|---|
| Name | XDmaPs_DA_n_OFFSET_7 |
| Relative Address | 0x000004E4 |
| Absolute Address | dmac0_ns: 0xF80044E4 dmac0_s: 0xF80034E4 |
| Width | 32 bits |
| Access Type | mixed |
| Reset Value | 0x00000000 |
| Description | Destination Addr DMA Channel 7 |

Register XDmaPs_DA_n_OFFSET_7 Details

| Field Name | Bits | Type | Reset Value | Description |
|------------|------|---------------------------|-------------|--|
| dest_addr | 31:0 | sro,ns sraz,n snsro | 0x0 | Destination data address (physical memory address) for DMA channel thread. |

Register ([dmac](#)) XDmaPs_CC_n_OFFSET_7

| | |
|------------------|---|
| Name | XDmaPs_CC_n_OFFSET_7 |
| Relative Address | 0x000004E8 |
| Absolute Address | dmac0_ns: 0xF80044E8 dmac0_s: 0xF80034E8 |
| Width | 32 bits |
| Access Type | mixed |
| Reset Value | dmac0_ns: 0x00000000 dmac0_s: 0x00800200 |
| Description | Channel Control DMA Channel 7 |

Register XDmaPs_CC_n_OFFSET_7 Details

| Field Name | Bits | Type | Reset Value | Description |
|------------------|-------|---------------------------|-------------|---|
| reserved | 31 | rud | 0x0 | reserved, read undefined |
| endian_swap_size | 30:28 | sro,ns sraz,n snsro | 0x0 | Data swap: little-endian and byte-invariant big-endian (BE-8) formats. 000: No swap, 8-bit data 001: Swap bytes within 16-bit data 010: Swap bytes within 32-bit data 011: Swap bytes within 64-bit data 100: Swap bytes within 128-bit data 101 to 111: Reserved |

| Field Name | Bits | Type | Reset Value | Description |
|----------------|-------|---------------------------|-------------------------------|--|
| dst_cache_ctrl | 27:25 | sro,ns sraz,n snsro | 0x0 | <p>Programs the AXI AWCACHE signals that are used when the DMAC writes to the destination (0: Low, 1: High):</p> <p>Bit [27] programs AWCACHE[3] Hardwired Low to AWCACHE[2] Bit [26] programs AWCACHE[1] Bit [25] programs AWCACHE[0] Note: Setting AWCACHE[3,1]=b10 violates the AXI protocol.</p> |
| dst_prot_ctrl | 24:22 | sro,ns sraz,n snsro | dmac0_ns: 0x0 dmac0_s: 0x2 | <p>Programs the AWPROT signals that are used when the DMAC writes the destination data (0: Low, 1: High):</p> <p>Bit [24] programs AWPROT[2] Bit [23] programs AWPROT[1] Bit [22] programs AWPROT[0] Note: Only DMA channels in the Secure state can program AWPROT[1] Low, that is, a secure access. If a DMA channel in the Non-secure state attempts to set AWPROT[1] Low, then the DMA channel aborts.</p> |
| dst_burst_len | 21:18 | sro,ns sraz,n snsro | 0x0 | <p>For each burst, these bits program the number of data transfers that the DMAC performs when it writes the destination data:</p> <p>0000: 1 data transfer 0001: 2 data transfers 0010: 3 data transfers ... 1111: 16 data transfers.</p> <p>The total number of bytes that the DMAC writes out of the MFIFO when it executes a DMAST instruction is the product of dst_burst_len and dst_burst_size. Note: These bits control the state of AWLEN[3:0].</p> |
| dst_burst_size | 17:15 | sro,ns sraz,n snsro | 0x0 | <p>For each beat within a burst, it programs the number of bytes that the DMAC writes to the destination:</p> <p>000: writes 1 byte per beat 001: writes 2 bytes per beat 010: writes 4 bytes per beat 011: writes 8 bytes per beat 100: writes 16 bytes per beat 101 to 111: reserved.</p> <p>The total number of bytes that the DMAC writes out of the MFIFO when it executes a DMAST instruction is the product of dst_burst_len and dst_burst_size. Note: These bits control the state of AWSIZE[2:0].</p> |

| Field Name | Bits | Type | Reset Value | Description |
|----------------|-------|---------------------------|-------------------------------|--|
| dst_inc | 14 | sro,ns sraz,n snsro | 0x0 | Programs the burst type that the DMAC performs when it writes the destination data: 0: Fixed-address burst. The DMAC signals AWBURST[0] Low. 1: Incrementing-address burst. The DMAC signals AWBURST[0] High. |
| src_cache_ctrl | 13:11 | sro,ns sraz,n snsro | 0x0 | Programs the AXI ARCACHE signals that are used for DMA reads of the source data (0: Low, 1: High): Bit [13] programs ARCACHE[2] Bit [12] programs ARCACHE[1] Bit [11] programs ARCACHE[0] Note: The DMAC ties ARCACHE[3] Low. Setting ARCACHE[2:1]= b10 violates the AXI protocol. |
| src_prot_ctrl | 10:8 | sro,ns sraz,n snsro | dmac0_ns: 0x0 dmac0_s: 0x2 | Programs the AXI ARPROT signals that are used for DMA reads of the source data (0: Low, 1: High): Bit [10] programs ARPROT[2] Bit [9] programs ARPROT[1] Bit [8] programs ARPROT[0] Note: Only DMA channels in the Secure state can program ARPROT[1] Low, that is, a secure access. If a DMA channel in the Non-secure state attempts to set ARPROT[1] Low, the DMA channel aborts. |
| src_burst_len | 7:4 | sro,ns sraz,n snsro | 0x0 | For each burst, these bits program the number of data transfers that the DMAC performs when it reads the source data: 0000: 1 data transfer 0001: 2 data transfers ... 1111: 16 data transfers. The total number of bytes that the DMAC reads into the MFIFO when it executes a DMALD instruction is the product of src_burst_len and src_burst_size. Note: These bits control the state of ARLEN[3:0]. |

| Field Name | Bits | Type | Reset Value | Description |
|----------------|------|---------------------------|-------------|--|
| src_burst_size | 3:1 | sro,ns sraz,n snsro | 0x0 | For each beat within a burst, it programs the number of bytes that the DMAC reads from the source: 000: reads 1 byte per beat 001: reads 2 bytes per beat 010: reads 4 bytes per beat 011: reads 8 bytes per beat 100: reads 16 bytes per beat 101 to 111: reserved. The total number of bytes that the DMAC reads into the MFIFO when it executes a DMALD instruction is the product of src_burst_len and src_burst_size. Note: These bits control the state of ARSIZE[2:0]. |
| src_inc | 0 | sro,ns sraz,n snsro | 0x0 | Programs the burst type that the DMAC performs when it reads the source data: 0: Fixed-address burst, DMAC signal ARBURST[0] driven Low. 1: Incrementing-address burst, DMAC signal ARBURST[0] driven High. |

Register ([dmac](#)) XDmaPs_LC0_n_OFFSET_7

| | |
|------------------|---|
| Name | XDmaPs_LC0_n_OFFSET_7 |
| Relative Address | 0x000004EC |
| Absolute Address | dmac0_ns: 0xF80044EC dmac0_s: 0xF80034EC |
| Width | 32 bits |
| Access Type | mixed |
| Reset Value | 0x00000000 |
| Description | Loop Counter 0 DMA Channel 7 |

Register XDmaPs_LC0_n_OFFSET_7 Details

| Field Name | Bits | Type | Reset Value | Description |
|------------------------|------|---------------------------|-------------|---|
| reserved | 31:8 | rud | 0x0 | reserved, read undefined |
| loop_counter_iteration | 7:0 | sro,ns sraz,n snsro | 0x0 | Provides the status of loop counter zero for the DMA channel thread. The DMAC updates this register when it executes DMALPEND[S][B], and the DMA channel thread is programmed to use loop counter zero. |

Register ([dmac](#)) XDmaPs_LC1_n_OFFSET_7

| | |
|------------------|---|
| Name | XDmaPs_LC1_n_OFFSET_7 |
| Relative Address | 0x000004F0 |
| Absolute Address | dmac0_ns: 0xF80044F0 dmac0_s: 0xF80034F0 |
| Width | 32 bits |
| Access Type | mixed |
| Reset Value | 0x00000000 |
| Description | Loop Counter 1 DMA Channel 7 |

Register XDmaPs_LC1_n_OFFSET_7 Details

| Field Name | Bits | Type | Reset Value | Description |
|------------------------|------|---------------------------|-------------|--|
| reserved | 31:8 | rud | 0x0 | reserved, read undefined |
| loop_counter_iteration | 7:0 | sro,ns sraz,n snsro | 0x0 | Provides the status of loop counter one for the DMA channel thread. The DMAC updates this register when it executes DMALPEND[S]B], and the DMA channel thread is programmed to use loop counter one. |

Register ([dmac](#)) XDMAPS_DBGSTATUS_OFFSET

| | |
|------------------|---|
| Name | XDMAPS_DBGSTATUS_OFFSET |
| Software Name | DBGSTATUS |
| Relative Address | 0x00000D00 |
| Absolute Address | dmac0_ns: 0xF8004D00 dmac0_s: 0xF8003D00 |
| Width | 32 bits |
| Access Type | mixed |
| Reset Value | 0x00000000 |
| Description | DMA Manager Execution Status |

Register XDMAPS_DBGSTATUS_OFFSET Details

| Field Name | Bits | Type | Reset Value | Description |
|------------|------|---------------------------|-------------|--|
| reserved | 31:1 | rud | 0x0 | reserved, read undefined |
| dbgstatus | 0 | sro,ns sraz,n snsro | 0x0 | The DMA manager Execution/Debug status: 0: Idle 1: Busy. |

Register ([dmac](#)) XDMAPS_DBGCMD_OFFSET

| | |
|------------------|---|
| Name | XDMAPS_DBGCMD_OFFSET |
| Software Name | DBGCMD |
| Relative Address | 0x00000D04 |
| Absolute Address | dmac0_ns: 0xF8004D04 dmac0_s: 0xF8003D04 |
| Width | 32 bits |
| Access Type | mixed |
| Reset Value | 0x00000000 |
| Description | DMA Manager Instr. Command |

Register XDMAPS_DBGCMD_OFFSET Details

| Field Name | Bits | Type | Reset Value | Description |
|------------|------|-------------------------------|-------------|---|
| reserved | 31:2 | rud | 0x0 | reserved, read undefined |
| dbgcmd | 1:0 | swo,n ssraz, nsnsw o | 0x0 | Command the DMA manager to execute the instruction defined in the two DBGINST registers. 00: execute the instruction. others: reserved. |

Register ([dmac](#)) XDMAPS_DBGINST0_OFFSET

| | |
|------------------|---|
| Name | XDMAPS_DBGINST0_OFFSET |
| Software Name | DBGINST0 |
| Relative Address | 0x00000D08 |
| Absolute Address | dmac0_ns: 0xF8004D08 dmac0_s: 0xF8003D08 |
| Width | 32 bits |
| Access Type | mixed |
| Reset Value | 0x00000000 |
| Description | DMA Manager Instruction Part A |

Register XDMAPS_DBGINST0_OFFSET Details

| Field Name | Bits | Type | Reset Value | Description |
|-------------------|-------|-------------------------------|-------------|---|
| instruction_byte1 | 31:24 | swo,n ssraz, nsnsw o | 0x0 | instruction byte 1 |
| instruction_byte0 | 23:16 | swo,n ssraz, nsnsw o | 0x0 | instruction byte 0 |
| reserved | 15:11 | waz | 0x0 | reserved, write as 0 |
| channel_num | 10:8 | swo,n ssraz, nsnsw o | 0x0 | DMA channel number: 000: DMA channel 0 001: DMA channel 1 010: DMA channel 2 ... 111: DMA channel 7 |
| reserved | 7:1 | waz | 0x0 | reserved, write as 0 |
| debug_thread | 0 | swo,n ssraz, nsnsw o | 0x0 | The debug thread encoding is as follows: 0: DMA manager thread 1: DMA channel. Note: When set to 1, the Channel number field selects the DMA channel to debug. |

Register ([dmac](#)) XDMAPS_DBGINST1_OFFSET

| | |
|------------------|---|
| Name | XDMAPS_DBGINST1_OFFSET |
| Software Name | DBGINST1 |
| Relative Address | 0x0000D0C |
| Absolute Address | dmac0_ns: 0xF8004D0C dmac0_s: 0xF8003D0C |
| Width | 32 bits |
| Access Type | mixed |
| Reset Value | 0x00000000 |
| Description | DMA Manager Instruction Part B |

Register XDMAPS_DBGINST1_OFFSET Details

| Field Name | Bits | Type | Reset Value | Description |
|-------------------|-------|-------------------------------|-------------|--------------------|
| instruction_byte5 | 31:24 | swo,n ssraz, nsnsw o | 0x0 | instruction byte 5 |
| instruction_byte4 | 23:16 | swo,n ssraz, nsnsw o | 0x0 | instruction byte 4 |
| instruction_byte3 | 15:8 | swo,n ssraz, nsnsw o | 0x0 | instruction byte 3 |
| instruction_byte2 | 7:0 | swo,n ssraz, nsnsw o | 0x0 | instruction byte 2 |

Register ([dmac](#)) XDMAPS_CR0_OFFSET

| | |
|------------------|--|
| Name | XDMAPS_CR0_OFFSET |
| Software Name | CR0 |
| Relative Address | 0x00000E00 |
| Absolute Address | dmac0_ns: 0xF8004E00 dmac0_s: 0xF8003E00 |
| Width | 32 bits |
| Access Type | mixed |
| Reset Value | dmac0_ns: 0x00000000 dmac0_s: 0x001E3071 |
| Description | Config. 0: Events, Peripheral Interfaces, PC, Mode |

Register XDMAPS_CR0_OFFSET Details

| Field Name | Bits | Type | Reset Value | Description |
|----------------|-------|---------------------------|-------------------------------|--|
| reserved | 31:22 | rud | 0x0 | read undefined |
| num_events | 21:17 | sro,ns sraz,n snsro | dmac0_ns: 0x0 dmac0_s: 0xF | The DMA Controller supports 16 events. This register always reads 01111 (15d). |
| num_periph_req | 16:12 | sro,ns sraz,n snsro | dmac0_ns: 0x0 dmac0_s: 0x3 | The DMA Controller supports four peripheral interfaces. This register always reads 00011 (3d). |
| reserved | 11:7 | rud | 0x0 | read undefined |

| Field Name | Bits | Type | Reset Value | Description |
|---------------|------|---------------------------|-------------------------------|--|
| num_chnls | 6:4 | sro,ns sraz,n snsro | dmac0_ns: 0x0 dmac0_s: 0x7 | The DMA Controller supports eight channel threads. This register always reads 00111 (7d). |
| reserved | 3 | rud | 0x0 | read undefined |
| mgr_ns_at_rst | 2 | sro,ns sraz,n snsro | 0x0 | Indicates the status of the slcr.TZ_DMA_NS bit when the DMAC exits from reset: 0: TZ_DMA_NS was Low 1: TZ_DMA_NS was High |
| boot_en | 1 | sro,ns sraz,n snsro | 0x0 | Indicates the status of the boot_from_pc signal when the DMAC exited from reset: 0 = boot_from_pc was LOW 1 = boot_from_pc was HIGH. |
| periph_req | 0 | sro,ns sraz,n snsro | dmac0_ns: 0x0 dmac0_s: 0x1 | The DMAC provides the peripheral request interfaces. |

Register ([dmac](#)) XDMAPS_CR1_OFFSET

| | |
|------------------|---|
| Name | XDMAPS_CR1_OFFSET |
| Software Name | CR1 |
| Relative Address | 0x00000E04 |
| Absolute Address | dmac0_ns: 0xF8004E04 dmac0_s: 0xF8003E04 |
| Width | 32 bits |
| Access Type | mixed |
| Reset Value | dmac0_ns: 0x00000000 dmac0_s: 0x00000074 |
| Description | Config. 1: Instruction Cache |

Register XDMAPS_CR1_OFFSET Details

| Field Name | Bits | Type | Reset Value | Description |
|------------------|------|---------------------------|-------------------------------|---|
| reserved | 31:8 | rud | 0x0 | read undefined |
| num_icache_lines | 7:4 | sro,ns sraz,n snsro | dmac0_ns: 0x0 dmac0_s: 0x7 | The DMAC iCache has eight lines. |
| reserved | 3 | rud | 0x0 | read undefined |
| icache_len | 2:0 | sro,ns sraz,n snsro | dmac0_ns: 0x0 dmac0_s: 0x4 | The length of an i-cache line is sixteen bytes. |

Register ([dmac](#)) XDMAPS_CR2_OFFSET

| | |
|------------------|---|
| Name | XDMAPS_CR2_OFFSET |
| Software Name | CR2 |
| Relative Address | 0x00000E08 |
| Absolute Address | dmac0_ns: 0xF8004E08 dmac0_s: 0xF8003E08 |
| Width | 32 bits |
| Access Type | mixed |
| Reset Value | 0x00000000 |
| Description | Config. 2: DMA Mgr Boot Addr |

Register XDMAPS_CR2_OFFSET Details

| Field Name | Bits | Type | Reset Value | Description |
|------------|------|---------------------------|-------------|---|
| boot_addr | 31:0 | sro,ns sraz,n snsro | 0x0 | The boot address for the DMAC manager is hardwired to 0. This is a system memory address. |

Register ([dmac](#)) XDMAPS_CR3_OFFSET

| | |
|------------------|---|
| Name | XDMAPS_CR3_OFFSET |
| Software Name | CR3 |
| Relative Address | 0x00000E0C |
| Absolute Address | dmac0_ns: 0xF8004E0C dmac0_s: 0xF8003E0C |
| Width | 32 bits |
| Access Type | mixed |
| Reset Value | 0x00000000 |
| Description | Config. 3: Security state of IRQs |

Register XDMAPS_CR3_OFFSET Details

| Field Name | Bits | Type | Reset Value | Description |
|------------|------|---------------------------|-------------|---|
| INS | 31:0 | sro,ns sraz,n snsro | 0x0 | The value of the slcr.TZ_DMA_IRQ_NS bits (boot_irq_ns signals) when the DMAC reset deasserts. Reserved |

Register ([dmac](#)) XDMAPS_CR4_OFFSET

| | |
|------------------|---|
| Name | XDMAPS_CR4_OFFSET |
| Software Name | CR4 |
| Relative Address | 0x00000E10 |
| Absolute Address | dmac0_ns: 0xF8004E10 dmac0_s: 0xF8003E10 |
| Width | 32 bits |
| Access Type | mixed |
| Reset Value | 0x00000000 |
| Description | Config 4, Security of Periph Interfaces |

Register XDMAPS_CR4_OFFSET Details

| Field Name | Bits | Type | Reset Value | Description |
|------------|------|---------------------------|-------------|---|
| PNS | 31:0 | sro,ns sraz,n snsro | 0x0 | Reflects the slcr.TZ_DMA_PERIPH_NS register values for the four peripheral request interfaces when the DMAC is unreset. 0: Secure state 1: Non-secure state Reserved |

Register ([dmac](#)) XDMAPS_CRDN_OFFSET

| | |
|------------------|---|
| Name | XDMAPS_CRDN_OFFSET |
| Software Name | CRDN |
| Relative Address | 0x00000E14 |
| Absolute Address | dmac0_ns: 0xF8004E14 dmac0_s: 0xF8003E14 |
| Width | 32 bits |
| Access Type | mixed |
| Reset Value | dmac0_ns: 0x00000000 dmac0_s: 0x07FF7F73 |
| Description | DMA configuration |

Register XDMAPS_CRDN_OFFSET Details

| Field Name | Bits | Type | Reset Value | Description |
|-----------------|-------|---------------------------|--------------------------------|--|
| reserved | 31:30 | rud | 0x0 | read undefined |
| data_buffer_dep | 29:20 | sro,ns sraz,n snsro | dmac0_ns: 0x0 dmac0_s: 0x7F | The MFIFO dept is 128 double words (64-bit). |

| Field Name | Bits | Type | Reset Value | Description |
|------------|-------|---------------------------|-------------------------------|---|
| rd_q_dep | 19:16 | sro,ns sraz,n snsro | dmac0_ns: 0x0 dmac0_s: 0xF | The depth of the Read Queue is hardwired at 16 lines. |
| reserved | 15 | rud | 0x0 | read undefined |
| rd_cap | 14:12 | sro,ns sraz,n snsro | dmac0_ns: 0x0 dmac0_s: 0x7 | The number of possible outstanding Read Transactions is hardwired at 8. |
| wr_q_dep | 11:8 | sro,ns sraz,n snsro | dmac0_ns: 0x0 dmac0_s: 0xF | The depth of the Write Queue is hardwired at 16 lines. |
| reserved | 7 | rud | 0x0 | read undefined |
| wr_cap | 6:4 | sro,ns sraz,n snsro | dmac0_ns: 0x0 dmac0_s: 0x7 | The number of outstanding Write Transactions is is hardwired at 8. |
| reserved | 3 | rud | 0x0 | read undefined |
| data_width | 2:0 | sro,ns sraz,n snsro | dmac0_ns: 0x0 dmac0_s: 0x3 | The data width of the AXI master interface 64 bits. |

Register ([dmac](#)) WD

| | |
|------------------|---|
| Name | WD |
| Relative Address | 0x00000E80 |
| Absolute Address | dmac0_ns: 0xF8004E80 dmac0_s: 0xF8003E80 |
| Width | 32 bits |
| Access Type | mixed |
| Reset Value | 0x00000000 |
| Description | Watchdog Timer |

Register WD Details

| Field Name | Bits | Type | Reset Value | Description |
|-------------|------|---------------------------|-------------|---|
| reserved | 31:1 | rud | 0x0 | read undefined |
| wd_irq_only | 0 | sro,ns sraz,n snsro | 0x0 | When a lock-up is detected, the DMAC aborts the DMA channel thread and asserts the Abort interrupt. |

Register ([dmac](#)) XDMAPS_PERIPH_ID_0_OFFSET

| | |
|---------------|---------------------------|
| Name | XDMAPS_PERIPH_ID_0_OFFSET |
| Software Name | PERIPH_ID_0 |

Relative Address 0x0000FE0
 Absolute Address dmac0_ns: 0xF8004FE0
 dmac0_s: 0xF8003FE0
 Width 32 bits
 Access Type mixed
 Reset Value dmac0_ns: 0x00000000
 dmac0_s: 0x00000030
 Description Peripheral Identification register 0

Register XDMAPS_PERIPH_ID_0_OFFSET Details

| Field Name | Bits | Type | Reset Value | Description |
|---------------|------|---------------------------|--------------------------------|----------------|
| reserved | 31:8 | rud | 0x0 | read undefined |
| part_number_0 | 7:0 | sro,ns sraz,n snsro | dmac0_ns: 0x0 dmac0_s: 0x30 | returns 0x30 |

Register ([dmac](#)) XDMAPS_PERIPH_ID_1_OFFSET

Name XDMAPS_PERIPH_ID_1_OFFSET
 Software Name PERIPH_ID_1
 Relative Address 0x0000FE4
 Absolute Address dmac0_ns: 0xF8004FE4
 dmac0_s: 0xF8003FE4
 Width 32 bits
 Access Type mixed
 Reset Value dmac0_ns: 0x00000000
 dmac0_s: 0x00000013
 Description Peripheral Identification register 1

Register XDMAPS_PERIPH_ID_1_OFFSET Details

| Field Name | Bits | Type | Reset Value | Description |
|---------------|------|---------------------------|-------------------------------|----------------|
| reserved | 31:8 | rud | 0x0 | read undefined |
| designer_0 | 7:4 | sro,ns sraz,n snsro | dmac0_ns: 0x0 dmac0_s: 0x1 | returns 0x1 |
| part_number_1 | 3:0 | sro,ns sraz,n snsro | dmac0_ns: 0x0 dmac0_s: 0x3 | returns 0x3 |

Register ([dmac](#)) XDMAPS_PERIPH_ID_2_OFFSET

| | |
|------------------|---|
| Name | XDMAPS_PERIPH_ID_2_OFFSET |
| Software Name | PERIPH_ID_2 |
| Relative Address | 0x0000FE8 |
| Absolute Address | dmac0_ns: 0xF8004FE8 dmac0_s: 0xF8003FE8 |
| Width | 32 bits |
| Access Type | mixed |
| Reset Value | dmac0_ns: 0x00000000 dmac0_s: 0x00000024 |
| Description | Peripheral Identification register 2 |

Register XDMAPS_PERIPH_ID_2_OFFSET Details

| Field Name | Bits | Type | Reset Value | Description |
|------------|------|---------------------------|-------------------------------|---------------------------|
| reserved | 31:8 | rud | 0x0 | read undefined |
| revision | 7:4 | sro,ns sraz,n snsro | dmac0_ns: 0x0 dmac0_s: 0x2 | DMAC IP revision is r1p1. |
| designer_1 | 3:0 | sro,ns sraz,n snsro | dmac0_ns: 0x0 dmac0_s: 0x4 | returns 0x4 |

Register ([dmac](#)) XDMAPS_PERIPH_ID_3_OFFSET

| | |
|------------------|---|
| Name | XDMAPS_PERIPH_ID_3_OFFSET |
| Software Name | PERIPH_ID_3 |
| Relative Address | 0x0000FEC |
| Absolute Address | dmac0_ns: 0xF8004FEC dmac0_s: 0xF8003FEC |
| Width | 32 bits |
| Access Type | mixed |
| Reset Value | 0x00000000 |
| Description | Peripheral Identification register 3 |

Register XDMAPS_PERIPH_ID_3_OFFSET Details

| Field Name | Bits | Type | Reset Value | Description |
|-----------------|------|---------------------------|-------------|--|
| reserved | 31:1 | rud | 0x0 | read undefined |
| integration_cfg | 0 | sro,ns sraz,n snsro | 0x0 | The DMAC does not contain integration test logic |

Register ([dmac](#)) XDMAPS_PCELL_ID_0_OFFSET

| | |
|------------------|---|
| Name | XDMAPS_PCELL_ID_0_OFFSET |
| Software Name | PCELL_ID_0 |
| Relative Address | 0x00000FF0 |
| Absolute Address | dmac0_ns: 0xF8004FF0 dmac0_s: 0xF8003FF0 |
| Width | 32 bits |
| Access Type | mixed |
| Reset Value | dmac0_ns: 0x00000000 dmac0_s: 0x0000000D |
| Description | Component Identification register 0 |

Register XDMAPS_PCELL_ID_0_OFFSET Details

| Field Name | Bits | Type | Reset Value | Description |
|------------|------|---------------------------|-------------------------------|----------------|
| reserved | 31:8 | rud | 0x0 | read undefined |
| pcell_id_0 | 7:0 | sro,ns sraz,n snsro | dmac0_ns: 0x0 dmac0_s: 0xD | returnx 0x0D |

Register ([dmac](#)) XDMAPS_PCELL_ID_1_OFFSET

| | |
|------------------|---|
| Name | XDMAPS_PCELL_ID_1_OFFSET |
| Software Name | PCELL_ID_1 |
| Relative Address | 0x00000FF4 |
| Absolute Address | dmac0_ns: 0xF8004FF4 dmac0_s: 0xF8003FF4 |
| Width | 32 bits |
| Access Type | mixed |
| Reset Value | dmac0_ns: 0x00000000 dmac0_s: 0x000000F0 |
| Description | Component Identification register 1 |

Register XDMAPS_PCELL_ID_1_OFFSET Details

| Field Name | Bits | Type | Reset Value | Description |
|------------|------|---------------------------|--------------------------------|----------------|
| reserved | 31:8 | rud | 0x0 | read undefined |
| pcell_id_1 | 7:0 | sro,ns sraz,n snsro | dmac0_ns: 0x0 dmac0_s: 0xF0 | returns 0xF0 |

Register ([dmac](#)) XDMAPS_PCELL_ID_2_OFFSET

| | |
|------------------|---|
| Name | XDMAPS_PCELL_ID_2_OFFSET |
| Software Name | PCELL_ID_2 |
| Relative Address | 0x0000FF8 |
| Absolute Address | dmac0_ns: 0xF8004FF8 dmac0_s: 0xF8003FF8 |
| Width | 32 bits |
| Access Type | mixed |
| Reset Value | dmac0_ns: 0x00000000 dmac0_s: 0x00000005 |
| Description | Component Identification register 2 |

Register XDMAPS_PCELL_ID_2_OFFSET Details

| Field Name | Bits | Type | Reset Value | Description |
|------------|------|---------------------------|-------------------------------|----------------|
| reserved | 31:8 | rud | 0x0 | read undefined |
| pcell_id_2 | 7:0 | sro,ns sraz,n snsro | dmac0_ns: 0x0 dmac0_s: 0x5 | returns 0x05 |

Register ([dmac](#)) XDMAPS_PCELL_ID_3_OFFSET

| | |
|------------------|---|
| Name | XDMAPS_PCELL_ID_3_OFFSET |
| Software Name | PCELL_ID_3 |
| Relative Address | 0x0000FFC |
| Absolute Address | dmac0_ns: 0xF8004FFC dmac0_s: 0xF8003FFC |
| Width | 32 bits |
| Access Type | mixed |
| Reset Value | dmac0_ns: 0x00000000 dmac0_s: 0x000000B1 |
| Description | Component Identification register 3 |

Register XDMAPS_PCELL_ID_3_OFFSET Details

| Field Name | Bits | Type | Reset Value | Description |
|------------|------|---------------------------|--------------------------------|----------------|
| reserved | 31:8 | rud | 0x0 | read undefined |
| pcell_id_3 | 7:0 | sro,ns sraz,n snsro | dmac0_ns: 0x0 dmac0_s: 0xB1 | returns 0xB1 |

B.18 Gigabit Ethernet Controller (GEM)

| | |
|--------------|------------------------------------|
| Module Name | Gigabit Ethernet Controller (GEM) |
| Base Address | 0xE000B000 gem0 0xE000C000 gem1 |
| Description | Gigabit Ethernet Controller |
| Vendor Info | |

Register Summary

| Register Name | Address | Width | Type | Reset Value | Description |
|--|------------|-------|-------|-------------|------------------------------------|
| XEMACPS_NWCTRL_OFFSET | 0x00000000 | 32 | mixed | 0x00000000 | Network Control |
| XEMACPS_NWCFG_OFFSET | 0x00000004 | 32 | rw | 0x00080000 | Network Configuration |
| XEMACPS_NWSR_OFFSET | 0x00000008 | 32 | ro | x | Network Status |
| XEMACPS_DMAGR_OFFSET | 0x00000010 | 32 | mixed | 0x00020784 | DMA Configuration |
| XEMACPS_TXSR_OFFSET | 0x00000014 | 32 | mixed | 0x00000000 | Transmit Status |
| XEMACPS_RXQBASE_OFFSET | 0x00000018 | 32 | mixed | 0x00000000 | Receive Buffer Queue Base Address |
| XEMACPS_TXQBASE_OFFSET | 0x0000001C | 32 | mixed | 0x00000000 | Transmit Buffer Queue Base Address |
| XEMACPS_RXSR_OFFSET | 0x00000020 | 32 | mixed | 0x00000000 | Receive Status |
| XEMACPS_ISR_OFFSET | 0x00000024 | 32 | mixed | 0x00000000 | Interrupt Status |
| XEMACPS_IER_OFFSET | 0x00000028 | 32 | wo | x | Interrupt Enable |
| XEMACPS_IDR_OFFSET | 0x0000002C | 32 | wo | x | Interrupt Disable |
| XEMACPS_IMR_OFFSET | 0x00000030 | 32 | mixed | x | Interrupt Mask Status |
| XEMACPS_PHYMNTN_OFFSET | 0x00000034 | 32 | rw | 0x00000000 | PHY Maintenance |
| XEMACPS_RXPAUSE_OFFSET | 0x00000038 | 32 | ro | 0x00000000 | Received Pause Quantum |
| XEMACPS_TXPAUSE_OFFSET | 0x0000003C | 32 | rw | 0x0000FFFF | Transmit Pause Quantum |
| XEMACPS_HASHL_OFFSET | 0x00000080 | 32 | rw | 0x00000000 | Hash Register Bottom [31:0] |
| XEMACPS_HASHH_OFFSET | 0x00000084 | 32 | rw | 0x00000000 | Hash Register Top [63:32] |

| Register Name | Address | Width | Type | Reset Value | Description |
|--|------------|-------|-------|-------------|--|
| XEMACPS_LADDR1L_OFFSET | 0x00000088 | 32 | rw | 0x00000000 | Specific Address 1 Bottom [31:0] |
| XEMACPS_LADDR1H_OFFSET | 0x0000008C | 32 | mixed | 0x00000000 | Specific Address 1 Top [47:32] |
| XEMACPS_LADDR2L_OFFSET | 0x00000090 | 32 | rw | 0x00000000 | Specific Address 2 Bottom [31:0] |
| XEMACPS_LADDR2H_OFFSET | 0x00000094 | 32 | mixed | 0x00000000 | Specific Address 2 Top [47:32] |
| XEMACPS_LADDR3L_OFFSET | 0x00000098 | 32 | rw | 0x00000000 | Specific Address 3 Bottom [31:0] |
| XEMACPS_LADDR3H_OFFSET | 0x0000009C | 32 | mixed | 0x00000000 | Specific Address 3 Top [47:32] |
| XEMACPS_LADDR4L_OFFSET | 0x000000A0 | 32 | rw | 0x00000000 | Specific Address 4 Bottom [31:0] |
| XEMACPS_LADDR4H_OFFSET | 0x000000A4 | 32 | mixed | 0x00000000 | Specific Address 4 Top [47:32] |
| XEMACPS_MATCH1_OFFSET | 0x000000A8 | 32 | mixed | 0x00000000 | Type ID Match 1 |
| XEMACPS_MATCH2_OFFSET | 0x000000AC | 32 | mixed | 0x00000000 | Type ID Match 2 |
| XEMACPS_MATCH3_OFFSET | 0x000000B0 | 32 | mixed | 0x00000000 | Type ID Match 3 |
| XEMACPS_MATCH4_OFFSET | 0x000000B4 | 32 | mixed | 0x00000000 | Type ID Match 4 |
| wake_on_lan | 0x000000B8 | 32 | mixed | 0x00000000 | Wake on LAN Register |
| XEMACPS_STRETCH_OFFSET | 0x000000BC | 32 | mixed | 0x00000000 | IPG stretch register |
| stacked_vlan | 0x000000C0 | 32 | mixed | 0x00000000 | Stacked VLAN Register |
| tx_pfc_pause | 0x000000C4 | 32 | mixed | 0x00000000 | Transmit PFC Pause Register |
| spec_addr1_mask_bot | 0x000000C8 | 32 | rw | 0x00000000 | Specific Address Mask 1 Bottom [31:0] |
| spec_addr1_mask_top | 0x000000CC | 32 | mixed | 0x00000000 | Specific Address Mask 1 Top [47:32] |
| module_id | 0x000000FC | 32 | ro | 0x00020118 | Module ID |
| XEMACPS_OCTTXL_OFFSET | 0x00000100 | 32 | ro | 0x00000000 | Octets transmitted [31:0] (in frames without error) |
| XEMACPS_OCTTXH_OFFSET | 0x00000104 | 32 | ro | 0x00000000 | Octets transmitted [47:32] (in frames without error) |
| XEMACPS_TXCNT_OFFSET | 0x00000108 | 32 | ro | 0x00000000 | Frames Transmitted |
| XEMACPS_TXBCCNT_OFFSET | 0x0000010C | 32 | ro | 0x00000000 | Broadcast frames Tx |
| XEMACPS_TXMCCNT_OFFSET | 0x00000110 | 32 | ro | 0x00000000 | Multicast frames Tx |

| Register Name | Address | Width | Type | Reset Value | Description |
|---|------------|-------|------|-------------|------------------------------------|
| XEMACPS_TXPAUSECNT_OFFSET | 0x00000114 | 32 | ro | 0x00000000 | Pause frames Tx |
| XEMACPS_TX64CNT_OFFSET | 0x00000118 | 32 | ro | 0x00000000 | Frames Tx, 64-byte length |
| XEMACPS_TX65CNT_OFFSET | 0x0000011C | 32 | ro | 0x00000000 | Frames Tx, 65 to 127-byte length |
| XEMACPS_TX128CNT_OFFSET | 0x00000120 | 32 | ro | 0x00000000 | Frames Tx, 128 to 255-byte length |
| XEMACPS_TX256CNT_OFFSET | 0x00000124 | 32 | ro | 0x00000000 | Frames Tx, 256 to 511-byte length |
| XEMACPS_TX512CNT_OFFSET | 0x00000128 | 32 | ro | 0x00000000 | Frames Tx, 512 to 1023-byte length |
| XEMACPS_TX1024CNT_OFFSET | 0x0000012C | 32 | ro | 0x00000000 | Frame Tx, 1024 to 1518-byte length |
| XEMACPS_TXURUNCNT_OFFSET | 0x00000134 | 32 | ro | 0x00000000 | Transmit under runs |
| XEMACPS_SNGLCOLLCNT_OFFSET | 0x00000138 | 32 | ro | 0x00000000 | Single Collision Frames |
| XEMACPS_MULTICOLLCNT_OFFSET | 0x0000013C | 32 | ro | 0x00000000 | Multiple Collision Frames |
| XEMACPS_EXCESSCOLLCNT_OFFSET | 0x00000140 | 32 | ro | 0x00000000 | Excessive Collisions |
| XEMACPS_LATECOLLCNT_OFFSET | 0x00000144 | 32 | ro | 0x00000000 | Late Collisions |
| XEMACPS_TXDEFERCNT_OFFSET | 0x00000148 | 32 | ro | 0x00000000 | Deferred Transmission Frames |
| XEMACPS_TXCSENSECNT_OFFSET | 0x0000014C | 32 | ro | 0x00000000 | Carrier Sense Errors. |
| XEMACPS_OCTRXL_OFFSET | 0x00000150 | 32 | ro | 0x00000000 | Octets Received [31:0] |
| XEMACPS_OCTRXLH_OFFSET | 0x00000154 | 32 | ro | 0x00000000 | Octets Received [47:32] |
| XEMACPS_RXCNT_OFFSET | 0x00000158 | 32 | ro | 0x00000000 | Frames Received |
| XEMACPS_RXBROADCASTCNT_OFFSET | 0x0000015C | 32 | ro | 0x00000000 | Broadcast Frames Rx |
| XEMACPS_RXMULTICNT_OFFSET | 0x00000160 | 32 | ro | 0x00000000 | Multicast Frames Rx |
| XEMACPS_RXPAUSECNT_OFFSET | 0x00000164 | 32 | ro | 0x00000000 | Pause Frames Rx |
| XEMACPS_RX64CNT_OFFSET | 0x00000168 | 32 | ro | 0x00000000 | Frames Rx, 64-byte length |
| XEMACPS_RX65CNT_OFFSET | 0x0000016C | 32 | ro | 0x00000000 | Frames Rx, 65 to 127-byte length |

| Register Name | Address | Width | Type | Reset Value | Description |
|--|------------|-------|------|-------------|-------------------------------------|
| XEMACPS_RX128CNT_OFFSET | 0x00000170 | 32 | ro | 0x00000000 | Frames Rx, 128 to 255-byte length |
| XEMACPS_RX256CNT_OFFSET | 0x00000174 | 32 | ro | 0x00000000 | Frames Rx, 256 to 511-byte length |
| XEMACPS_RX512CNT_OFFSET | 0x00000178 | 32 | ro | 0x00000000 | Frames Rx, 512 to 1023-byte length |
| XEMACPS_RX1024CNT_OFFSET | 0x0000017C | 32 | ro | 0x00000000 | Frames Rx, 1024 to 1518-byte length |
| XEMACPS_RXUNDRCNT_OFFSET | 0x00000184 | 32 | ro | 0x00000000 | Undersize frames received |
| XEMACPS_RXOVRCNT_OFFSET | 0x00000188 | 32 | ro | 0x00000000 | Oversize frames received |
| XEMACPS_RXJABCNT_OFFSET | 0x0000018C | 32 | ro | 0x00000000 | Jabbers received |
| XEMACPS_RXFCSCNT_OFFSET | 0x00000190 | 32 | ro | 0x00000000 | Frame check sequence errors |
| XEMACPS_RXLENGTHCNT_OFFSET | 0x00000194 | 32 | ro | 0x00000000 | Length field frame errors |
| XEMACPS_RXSYMBCNT_OFFSET | 0x00000198 | 32 | ro | 0x00000000 | Receive symbol errors |
| XEMACPS_RXALIGNCNT_OFFSET | 0x0000019C | 32 | ro | 0x00000000 | Alignment errors |
| XEMACPS_RXRESERRCNT_OFFSET | 0x000001A0 | 32 | ro | 0x00000000 | Receive resource errors |
| XEMACPS_RXORCNT_OFFSET | 0x000001A4 | 32 | ro | 0x00000000 | Receive overrun errors |
| XEMACPS_RXIPCCNT_OFFSET | 0x000001A8 | 32 | ro | 0x00000000 | IP header checksum errors |
| XEMACPS_RXTCCNT_OFFSET | 0x000001AC | 32 | ro | 0x00000000 | TCP checksum errors |
| XEMACPS_RXUDPCNT_OFFSET | 0x000001B0 | 32 | ro | 0x00000000 | UDP checksum error |
| design_cfg2 | 0x00000284 | 32 | ro | x | Design Configuration 2 |
| design_cfg3 | 0x00000288 | 32 | ro | 0x00000000 | Design Configuration 3 |
| design_cfg4 | 0x0000028C | 32 | ro | 0x00000000 | Design Configuration 4 |
| design_cfg5 | 0x00000290 | 32 | ro | x | Design Configuration 5 |

Register ([GEM](#)) XEMACPS_NWCTRL_OFFSET

Name XEMACPS_NWCTRL_OFFSET
 Software Name XEMACPS_NWCTRL
 Relative Address 0x00000000

| | |
|------------------|--------------------------------------|
| Absolute Address | gem0: 0xE000B000 gem1: 0xE000C000 |
| Width | 32 bits |
| Access Type | mixed |
| Reset Value | 0x00000000 |
| Description | Network Control |

Register XEMACPS_NWCTRL_OFFSET Details

The network control register contains general MAC control functions for both receiver and transmitter.

| Field Name | Bits | Type | Reset Value | Description |
|---|-------|------|-------------|---|
| reserved | 31:19 | ro | 0x0 | Reserved, read as zero, ignored on write. |
| flush_next_rx_dpram_pkt | 18 | wo | 0x0 | Flush the next packet from the external RX DPRAM. Writing one to this bit will only have an effect if the DMA is not currently writing a packet already stored in the DPRAM to memory. |
| tx_pfc_pri_pause_frame | 17 | wo | 0x0 | Transmit PFC Priority Based Pause Frame. Takes the values stored in the Transmit PFC Pause Register |
| en_pfc_pri_pause_rx | 16 | wo | 0x0 | Enable PFC Priority Based Pause Reception capabilities. Setting this bit will enable PFC negotiation and recognition of priority based pause frames. |
| reserved | 15 | rw | 0x0 | Reserved. Do not modify. |
| reserved | 14 | rw | 0x0 | Reserved. Do not modify. |
| reserved | 13 | wo | 0x0 | Reserved. Do not modify. |
| XEMACPS_NWCTRL_ZEROPAUSETX_MASK (ZEROPAUSETX) | 12 | wo | 0x0 | Transmit zero quantum pause frame. Writing one to this bit causes a pause frame with zero quantum to be transmitted. |
| XEMACPS_NWCTRL_PAUSETX_MASK (PAUSETX) | 11 | wo | 0x0 | Transmit pause frame - writing one to this bit causes a pause frame to be transmitted. |
| XEMACPS_NWCTRL_HALTTX_MASK (HALTTX) | 10 | wo | 0x0 | Transmit halt - writing one to this bit halts transmission as soon as any ongoing frame transmission ends. |
| XEMACPS_NWCTRL_STARTTX_MASK (STARTTX) | 9 | wo | 0x0 | Start transmission - writing one to this bit starts transmission. |
| back_pressure | 8 | rw | 0x0 | Back pressure - if set in 10M or 100M half duplex mode will force collisions on all received frames. |

| Field Name | Bits | Type | Reset Value | Description |
|--|------|------|-------------|---|
| XEMACPS_NWCTRL_ST ATWEN_MASK (STATWEN) | 7 | rw | 0x0 | Write enable for statistics registers - setting this bit to one means the statistics registers can be written for functional test purposes. |
| XEMACPS_NWCTRL_ST ATINC_MASK (STATINC) | 6 | wo | 0x0 | Incremental statistics registers - this bit is write only. Writing a one increments all the statistics registers by one for test purposes. |
| XEMACPS_NWCTRL_ST ATCLR_MASK (STATCLR) | 5 | wo | 0x0 | Clear statistics registers - this bit is write only. Writing a one clears the statistics registers. |
| XEMACPS_NWCTRL_M DEN_MASK (MDEN) | 4 | rw | 0x0 | Management port enable - set to one to enable the management port. When zero forces mdio to high impedance state and mdc low. |
| XEMACPS_NWCTRL_TX EN_MASK (TXEN) | 3 | rw | 0x0 | Transmit enable - when set, it enables the GEM transmitter to send data. When reset transmission will stop immediately, the transmit pipeline and control registers will be cleared and the transmit queue pointer register will reset to point to the start of the transmit descriptor list. |
| XEMACPS_NWCTRL_RX EN_MASK (RXEN) | 2 | rw | 0x0 | Receive enable - when set, it enables the GEM to receive data. When reset frame reception will stop immediately and the receive pipeline will be cleared. The receive queue pointer register is unaffected. |
| XEMACPS_NWCTRL_LO OPEN_MASK (LOOPEN) | 1 | rw | 0x0 | Loop back local - asserts the loopback_local signal to the system clock generator. Also connects txd to rxd, tx_en to rx_dv and forces full duplex mode. Bit 11 of the network configuration register must be set low to disable TBI mode when in internal loopback. rx_clk and tx_clk may malfunction as the GEM is switched into and out of internal loop back. It is important that receive and transmit circuits have already been disabled when making the switch into and out of internal loop back. Local loopback functionality isn't available in the EP107 Zynq Emulation Platform, because the clocking doesn't map well into an FPGA. |
| reserved | 0 | rw | 0x0 | Reserved. Do not modify. |

Register ([GEM](#)) XEMACPS_NWCFG_OFFSET

Name XEMACPS_NWCFG_OFFSET
 Software Name XEMACPS_NWCFG
 Relative Address 0x00000004
 Absolute Address gem0: 0xE000B004
 gem1: 0xE000C004

| | |
|-------------|-----------------------|
| Width | 32 bits |
| Access Type | rw |
| Reset Value | 0x00080000 |
| Description | Network Configuration |

Register XEMACPS_NWCFG_OFFSET Details

The network configuration register contains functions for setting the mode of operation for the Gigabit Ethernet MAC

| Field Name | Bits | Type | Reset Value | Description |
|---|------|------|-------------|--|
| unidir_en | 31 | rw | 0x0 | NA. |
| ignore_ipg_rx_er | 30 | rw | 0x0 | Ignore IPG rx_er. When set rx_er has no effect on the GEM's operation when rx_dv is low. Set this when using the RGMII wrapper in half-duplex mode. |
| XEMACPS_NWCFG_BA DPREAMBEN_MASK (BADPREAMBEN) | 29 | rw | 0x0 | Receive bad preamble. When set frames with non-standard preamble are not rejected. |
| XEMACPS_NWCFG_IPD STRETCH_MASK (IPDSTRETCH) | 28 | rw | 0x0 | IPG stretch enable - when set the transmit IPG can be increased above 96 bit times depending on the previous frame length using the IPG stretch register. |
| sgmii_en | 27 | rw | 0x0 | SGMII mode enable - changes behavior of the auto-negotiation advertisement and link partner ability registers to meet the requirements of SGMII and reduces the duration of the link timer from 10 ms to 1.6 ms |
| XEMACPS_NWCFG_FCS IGNORE_MASK (FCSIGNORE) | 26 | rw | 0x0 | Ignore RX FCS - when set frames with FCS/CRC errors will not be rejected. FCS error statistics will still be collected for frames with bad FCS and FCS status will be recorded in frame's DMA descriptor. For normal operation this bit must be set to zero. |
| XEMACPS_NWCFG_HD RXEN_MASK (HDRXEN) | 25 | rw | 0x0 | Enable frames to be received in half-duplex mode while transmitting. |
| XEMACPS_NWCFG_RXC HKSUMEN_MASK (RXCHKSUMEN) | 24 | rw | 0x0 | Receive checksum offload enable - when set, the receive checksum engine is enabled. Frames with bad IP, TCP or UDP checksums are discarded. |

| Field Name | Bits | Type | Reset Value | Description |
|---|-------|------|-------------|--|
| XEMACPS_NWCFG_PAUSECOPYDI_MASK (PAUSECOPYDI) | 23 | rw | 0x0 | Disable copy of pause frames - set to one to prevent valid pause frames being copied to memory. When set, pause frames are not copied to memory regardless of the state of the copy all frames bit; whether a hash match is found or whether a type ID match is identified. If a destination address match is found the pause frame will be copied to memory. Note that valid pause frames received will still increment pause statistics and pause the transmission of frames as required. |
| dbus_width | 22:21 | rw | 0x0 | Data bus width. Only valid bus widths may be written if the system is configured to a maximum width less than 128-bits. Zynq defines gem_dma_bus_width_def as 2'b00. 00: 32 bit AMBA AHB data bus width 01: 64 bit AMBA AHB data bus width 10: 128 bit AMBA AHB data bus width 11: 128 bit AMBA AHB data bus width |
| XEMACPS_NWCFG_MDCCCLKDIV_MASK (MDCCLKDIV) | 20:18 | rw | 0x2 | MDC clock division - set according to cpu_1xclk speed. These three bits determine the number cpu_1xclk will be divided by to generate MDC. For conformance with the 802.3 specification, MDC must not exceed 2.5 MHz (MDC is only active during MDIO read and write operations). 000: divide cpu_1xclk by 8 (cpu_1xclk up to 20 MHz) 001: divide cpu_1xclk by 16 (cpu_1xclk up to 40 MHz) 010: divide cpu_1xclk by 32 (cpu_1xclk up to 80 MHz) 011: divide cpu_1xclk by 48 (cpu_1xclk up to 120MHz) 100: divide cpu_1xclk by 64 (cpu_1xclk up to 160 MHz) 101: divide cpu_1xclk by 96 (cpu_1xclk up to 240 MHz) 110: divide cpu_1xclk by 128 (cpu_1xclk up to 320 MHz) 111: divide cpu_1xclk by 224 (cpu_1xclk up to 540 MHz) |
| XEMACPS_NWCFG_FCSREM_MASK (FCSREM) | 17 | rw | 0x0 | FCS remove - setting this bit will cause received frames to be written to memory without their frame check sequence (last 4 bytes). The frame length indicated will be reduced by four bytes in this mode. |

| Field Name | Bits | Type | Reset Value | Description |
|---|-------|------|-------------|--|
| XEMACPS_NWCFG_LEN GTHERRDSCRD_MASK (LENGTHERDSCRD) | 16 | rw | 0x0 | Length field error frame discard - setting this bit causes frames with a measured length shorter than the extracted length field (as indicated by bytes 13 and 14 in a non-VLAN tagged frame) to be discarded. This only applies to frames with a length field less than 0x0600. |
| XEMACPS_NWCFG_RX OFFS_MASK (RXOFFS) | 15:14 | rw | 0x0 | Receive buffer offset - indicates the number of bytes by which the received data is offset from the start of the receive buffer. |
| XEMACPS_NWCFG_PAU SEEN_MASK (PAUSEEN) | 13 | rw | 0x0 | Pause enable - when set, transmission will pause if a non zero 802.3 classic pause frame is received and PFC has not been negotiated. |
| XEMACPS_NWCFG_RET RYTESTEN_MASK (RETRYTESTEN) | 12 | rw | 0x0 | Retry test - must be set to zero for normal operation. If set to one the backoff between collisions will always be one slot time. Setting this bit to one helps test the too many retries condition. Also used in the pause frame tests to reduce the pause counter's decrement time from 512 bit times, to every rx_clk cycle. |
| pcs_sel | 11 | rw | 0x0 | NA 0: GMII/MII interface enabled, TBI disabled 1: TBI enabled, GMII/MII disabled |
| XEMACPS_NWCFG_100 0_MASK (1000) | 10 | rw | 0x0 | Gigabit mode enable - setting this bit configures the GEM for 1000 Mbps operation. 0: 10/100 operation using MII or TBI interface 1: Gigabit operation using GMII or TBI interface |
| XEMACPS_NWCFG_EXT ADDRMATCHEN_MASK (EXTADDRMATCHEN) | 9 | rw | 0x0 | External address match enable - when set the external address match interface can be used to copy frames to memory. |
| XEMACPS_NWCFG_153 6RXEN_MASK (1536RXEN) | 8 | rw | 0x0 | Receive 1536 byte frames - setting this bit means the GEM will accept frames up to 1536 bytes in length. Normally the GEM would reject any frame above 1518 bytes. |
| XEMACPS_NWCFG_UC ASTHASHEN_MASK (UCASTHASHEN) | 7 | rw | 0x0 | Unicast hash enable - when set, unicast frames will be accepted when the 6 bit hash function of the destination address points to a bit that is set in the hash register. |
| XEMACPS_NWCFG_MC ASTHASHEN_MASK (MCASTHASHEN) | 6 | rw | 0x0 | Multicast hash enable - when set, multicast frames will be accepted when the 6 bit hash function of the destination address points to a bit that is set in the hash register. |
| XEMACPS_NWCFG_BCA STDI_MASK (BCASTDI) | 5 | rw | 0x0 | No broadcast - when set to logic one, frames addressed to the broadcast address of all ones will not be accepted. |
| XEMACPS_NWCFG_CO PYALLEN_MASK (COPYALLEN) | 4 | rw | 0x0 | Copy all frames - when set to logic one, all valid frames will be accepted. |

| Field Name | Bits | Type | Reset Value | Description |
|---|------|------|-------------|--|
| reserved | 3 | rw | 0x0 | Reserved. Do not modify. |
| XEMACPS_NWCFG_NVL ANDISC_MASK (NVLANDISC) | 2 | rw | 0x0 | Discard non-VLAN frames - when set only VLAN tagged frames will be passed to the address matching logic. |
| XEMACPS_NWCFG_FDE N_MASK (FDEN) | 1 | rw | 0x0 | Full duplex - if set to logic one, the transmit block ignores the state of collision and carrier sense and allows receive while transmitting. Also controls the half-duplex pin. |
| XEMACPS_NWCFG_100 _MASK (100) | 0 | rw | 0x0 | Speed - set to logic one to indicate 100Mbps operation, logic zero for 10Mbps. The value of this pin is reflected on the speed_mode[0] output pin. |

Register ([GEM](#)) XEMACPS_NWSR_OFFSET

| | |
|------------------|--------------------------------------|
| Name | XEMACPS_NWSR_OFFSET |
| Software Name | XEMACPS_NWSR |
| Relative Address | 0x00000008 |
| Absolute Address | gem0: 0xE000B008 gem1: 0xE000C008 |
| Width | 32 bits |
| Access Type | ro |
| Reset Value | x |
| Description | Network Status |

Register XEMACPS_NWSR_OFFSET Details

The network status register returns status information with respect to the PHY management interface.

| Field Name | Bits | Type | Reset Value | Description |
|------------------------------|------|------|-------------|--|
| reserved | 31:7 | ro | 0x0 | Reserved, read as zero, ignored on write. |
| pfc_pri_pause_neg | 6 | ro | 0x0 | Set when PFC Priority Based Pause has been negotiated. |
| pcs_autoneg_pause_tx_ res | 5 | ro | 0x0 | NA |
| pcs_autoneg_pause_rx_ res | 4 | ro | 0x0 | NA |
| pcs_autoneg_dup_res | 3 | ro | 0x0 | NA |
| phy_mgmt_idle | 2 | ro | 0x1 | The PHY management logic is idle (i.e. has completed). |

| Field Name | Bits | Type | Reset Value | Description |
|--------------------------------|------|------|-------------|-----------------------------------|
| XEMACPS_NWSR_MDI_O_MASK (MDIO) | 1 | ro | x | Returns status of the mdio_in pin |
| pcs_link_state | 0 | ro | 0x0 | NA |

Register (GEM) XEMACPS_DMACR_OFFSET

| | |
|------------------|--------------------------------------|
| Name | XEMACPS_DMACR_OFFSET |
| Software Name | XEMACPS_DMACR |
| Relative Address | 0x00000010 |
| Absolute Address | gem0: 0xE000B010 gem1: 0xE000C010 |
| Width | 32 bits |
| Access Type | mixed |
| Reset Value | 0x00020784 |
| Description | DMA Configuration |

Register XEMACPS_DMACR_OFFSET Details

| Field Name | Bits | Type | Reset Value | Description |
|----------------------------------|-------|------|-------------|---|
| reserved | 31:25 | ro | 0x0 | Reserved, read as zero, ignored on write. |
| disc_when_no_ahb | 24 | rw | 0x0 | When set, the GEM DMA will automatically discard receive packets from the receiver packet buffer memory when no AHB resource is available. When low, then received packets will remain to be stored in the SRAM based packet buffer until AHB buffer resource next becomes available. |
| XEMACPS_DMACR_RXBUF_MASK (RXBUF) | 23:16 | rw | 0x2 | DMA receive buffer size in AHB system memory. The value defined by these bits determines the size of buffer to use in main AHB system memory when writing received data. The value is defined in multiples of 64 bytes such that a value of 0x01 corresponds to buffers of 64 bytes, 0x02 corresponds to 128 bytes etc. For example: 0x02: 128 byte 0x18: 1536 byte (1*max length frame/buffer) 0xA0: 10240 byte (1*10k jumbo frame/buffer) Note that this value should never be written as zero. |
| reserved | 15:12 | ro | 0x0 | Reserved, read as zero, ignored on write. |

| Field Name | Bits | Type | Reset Value | Description |
|--|------|------|-------------|---|
| XEMACPS_DMACR_TCPCKSUM_MASK (TCPCKSUM) | 11 | rw | 0x0 | Transmitter IP, TCP and UDP checksum generation offload enable. When set, the transmitter checksum generation engine is enabled, to calculate and substitute checksums for transmit frames. When clear, frame data is unaffected. If the GEM is not configured to use the DMA packet buffer, this bit is not implemented and will be treated as reserved, read as zero, ignored on write. Zynq uses packet buffer. |
| XEMACPS_DMACR_TXSIZE_MASK (TXSIZE) | 10 | rw | 0x1 | Transmitter packet buffer memory size select - Having this bit at zero halves the amount of memory used for the transmit packet buffer. This reduces the amount of memory used by the GEM. It is important to set this bit to one if the full configured physical memory is available. The value in brackets below represents the size that would result for the default maximum configured memory size of 4 kB. 1: Use full configured addressable space (4 kB) 0: Do not use top address bit (2 kB) If the GEM is not configured to use the DMA packet buffer, this bit is not implemented and will be treated as reserved, read as zero, ignored on write. Zynq uses packet buffer. |
| XEMACPS_DMACR_RXSIZE_MASK (RXSIZE) | 9:8 | rw | 0x3 | Receiver packet buffer memory size select - Having these bits at less than 11 reduces the amount of memory used for the receive packet buffer. This reduces the amount of memory used by the GEM. It is important to set these bits both to one if the full configured physical memory is available. The value in brackets below represents the size that would result for the default maximum configured memory size of 8 kB. 00: Do not use top three address bits (1 kB) 01: Do not use top two address bits (2 kB) 10: Do not use top address bit (4 kB) 11: Use full configured addressable space (8 kB) If the controller is not configured to use the DMA packet buffer, these bits are not implemented and will be treated as reserved, read as zero, ignored on write. Zynq uses packet buffer. |
| XEMACPS_DMACR_ENDIAN_MASK (ENDIAN) | 7 | rw | 0x1 | AHB endian swap mode enable for packet data accesses - When set, selects swapped endianism for AHB transfers. When clear, selects little endian mode. |
| ahb_endian_swp_mgmt_en | 6 | rw | 0x0 | AHB endian swap mode enable for management descriptor accesses - When set, selects swapped endianism for AHB transfers. When clear, selects little endian mode. |

| Field Name | Bits | Type | Reset Value | Description |
|--------------------------------------|------|------|-------------|---|
| reserved | 5 | rw | 0x0 | Reserved, read as zero, ignored on write |
| XEMACPS_DMACR_BLENGTH_MASK (BLENGTH) | 4:0 | rw | 0x4 | AHB fixed burst length for DMA data operations - Selects the burst length to attempt to use on the AHB when transferring frame data. Not used for DMA management operations and only used where space and data size allow. Otherwise SINGLE type AHB transfers are used. Upper bits become non-writeable if the configured DMA TX and RX FIFO sizes are smaller than required to support the selected burst size. One-hot priority encoding enforced automatically on register writes as follows, where 'x' represents don't care: 00001: Always use SINGLE AHB bursts 0001x: Always use SINGLE AHB bursts 001xx: Attempt to use INCR4 AHB bursts (default) 01xxx: Attempt to use INCR8 AHB bursts 1xxxx: Attempt to use INCR16 AHB bursts others: reserved |

Register (GEM) XEMACPS_TXSR_OFFSET

| | |
|------------------|--------------------------------------|
| Name | XEMACPS_TXSR_OFFSET |
| Software Name | XEMACPS_TXSR |
| Relative Address | 0x00000014 |
| Absolute Address | gem0: 0xE000B014 gem1: 0xE000C014 |
| Width | 32 bits |
| Access Type | mixed |
| Reset Value | 0x00000000 |
| Description | Transmit Status |

Register XEMACPS_TXSR_OFFSET Details

This register, when read, provides details of the status of a transmit. Once read, individual bits may be cleared by writing 1 to them. It is not possible to set a bit to 1 by writing to the register.

| Field Name | Bits | Type | Reset Value | Description |
|--|------|------|-------------|--|
| reserved | 31:9 | ro | 0x0 | Reserved, read as zero, ignored on write. |
| XEMACPS_TXSR_HRESP_NOK_MASK (HRESPNOK) | 8 | wtc | 0x0 | Hresp not OK - set when the DMA block sees hresp not OK. Cleared by writing a one to this bit. |

| Field Name | Bits | Type | Reset Value | Description |
|-------------------------------------|------|------|-------------|---|
| late_collision | 7 | wtc | 0x0 | Late collision occurred - only set if the condition occurs in gigabit mode, as retry is not attempted. Cleared by writing a one to this bit. |
| XEMACPS_TXSR_URUN_MASK (URUN) | 6 | wtc | 0x0 | <p>Transmit under run - this bit is set if the transmitter was forced to terminate a frame that it had already began transmitting due to further data being unavailable.</p> <p>This bit is set if a transmitter status write back has not completed when another status write back is attempted.</p> <p>When using the DMA interface configured for internal FIFO mode, this bit is also set when the transmit DMA has written the SOP data into the FIFO and either the AHB bus was not granted in time for further data, or because an AHB not OK response was returned, or because a used bit was read.</p> <p>When using the DMA interface configured for packet buffer mode, this bit will never be set.</p> <p>When using the external FIFO interface, this bit is also set when the tx_r_underflow input is asserted during a frame transfer. Cleared by writing a 1.</p> |
| XEMACPS_TXSR_TXCOMPL_MASK (TXCOMPL) | 5 | wtc | 0x0 | Transmit complete - set when a frame has been transmitted. Cleared by writing a one to this bit. |
| XEMACPS_TXSR_BUFEXH_MASK (BUFEXH) | 4 | wtc | 0x0 | <p>Transmit frame corruption due to AHB error - set if an error occurs whilst midway through reading transmit frame from the AHB, including HRESP errors and buffers exhausted mid frame (if the buffers run out during transmission of a frame then transmission stops, FCS shall be bad and tx_er asserted).</p> <p>Also set in DMA packet buffer mode if single frame is too large for configured packet buffer memory size.</p> <p>Cleared by writing a one to this bit.</p> |
| XEMACPS_TXSR_TXGO_MASK (TXGO) | 3 | ro | 0x0 | <p>Transmit go - if high transmit is active.</p> <p>When using the exposed FIFO interface, this bit represents bit 3 of the network control register.</p> <p>When using the DMA interface this bit represents the tx_go variable as specified in the transmit buffer description.</p> |
| XEMACPS_TXSR_RXOVR_MASK (RXOVR) | 2 | wtc | 0x0 | Retry limit exceeded - cleared by writing a one to this bit. |

| Field Name | Bits | Type | Reset Value | Description |
|---------------------------------------|------|------|-------------|--|
| XEMACPS_TXSR_FRAMERX_MASK (FRAMERX) | 1 | wtc | 0x0 | Collision occurred - set by the assertion of collision. Cleared by writing a one to this bit. When operating in 10/100 mode, this status indicates either a collision or a late collision. In gigabit mode, this status is not set for a late collision. |
| XEMACPS_TXSR_USEDREAD_MASK (USEDREAD) | 0 | wtc | 0x0 | Used bit read - set when a transmit buffer descriptor is read with its used bit set. Cleared by writing a one to this bit. |

Register ([GEM](#)) XEMACPS_RXQBASE_OFFSET

| | |
|------------------|--------------------------------------|
| Name | XEMACPS_RXQBASE_OFFSET |
| Software Name | XEMACPS_RXQBASE |
| Relative Address | 0x00000018 |
| Absolute Address | gem0: 0xE000B018 gem1: 0xE000C018 |
| Width | 32 bits |
| Access Type | mixed |
| Reset Value | 0x00000000 |
| Description | Receive Buffer Queue Base Address |

Register XEMACPS_RXQBASE_OFFSET Details

This register holds the start address of the receive buffer queue (receive buffers descriptor list). The receive buffer queue base address must be initialized before receive is enabled through bit 2 of the network control register. Once reception is enabled, any write to the receive buffer queue base address register is ignored. Reading this register returns the location of the descriptor currently being accessed. This value increments as buffers are used. Software should not use this register for determining where to remove received frames from the queue as it constantly changes as new frames are received. Software should instead work its way through the buffer descriptor queue checking the 'used' bits.

The descriptors should be aligned at 32-bit boundaries and the descriptors are written to using two individual non sequential accesses.

| Field Name | Bits | Type | Reset Value | Description |
|---------------|------|------|-------------|---|
| rx_q_baseaddr | 31:2 | rw | 0x0 | Receive buffer queue base address - written with the address of the start of the receive queue. |
| reserved | 1:0 | ro | 0x0 | Reserved, read as 0, ignored on write. |

Register ([GEM](#)) XEMACPS_TXQBASE_OFFSET

| | |
|------------------|--------------------------------------|
| Name | XEMACPS_TXQBASE_OFFSET |
| Software Name | XEMACPS_TXQBASE |
| Relative Address | 0x0000001C |
| Absolute Address | gem0: 0xE000B01C gem1: 0xE000C01C |
| Width | 32 bits |
| Access Type | mixed |
| Reset Value | 0x00000000 |
| Description | Transmit Buffer Queue Base Address |

Register XEMACPS_TXQBASE_OFFSET Details

This register holds the start address of the transmit buffer queue (transmit buffers descriptor list). The transmit buffer queue base address register must be initialized before transmit is started through bit 9 of the network control register. Once transmission has started, any write to the transmit buffer queue base address register is illegal and therefore ignored.

Note that due to clock boundary synchronization, it takes a maximum of four pclk cycles from the writing of the transmit start bit before the transmitter is active. Writing to the transmit buffer queue base address register during this time may produce unpredictable results.

Reading this register returns the location of the descriptor currently being accessed. Since the DMA handles two frames at once, this may not necessarily be pointing to the current frame being transmitted.

The descriptors should be aligned at 32-bit boundaries and the descriptors are read from memory using two individual non sequential accesses.

| Field Name | Bits | Type | Reset Value | Description |
|----------------|------|------|-------------|---|
| tx_q_base_addr | 31:2 | rw | 0x0 | Transmit buffer queue base address - written with the address of the start of the transmit queue. |
| reserved | 1:0 | ro | 0x0 | Reserved, read as 0, ignored on write. |

Register ([GEM](#)) XEMACPS_RXSR_OFFSET

| | |
|------------------|--------------------------------------|
| Name | XEMACPS_RXSR_OFFSET |
| Software Name | XEMACPS_RXSR |
| Relative Address | 0x00000020 |
| Absolute Address | gem0: 0xE000B020 gem1: 0xE000C020 |
| Width | 32 bits |
| Access Type | mixed |

Reset Value 0x00000000
 Description Receive Status

Register XEMACPS_RXSR_OFFSET Details

When read provides details of the status of a receive. Once read, individual bits may be cleared by writing 1 to them. It is not possible to set a bit to 1 by writing to the register.

| Field Name | Bits | Type | Reset Value | Description |
|--|------|------|-------------|--|
| reserved | 31:4 | ro | 0x0 | Reserved, read as 0, ignored on write. |
| XEMACPS_RXSR_HRESP_NOK_MASK (HRESPNOK) | 3 | wtc | 0x0 | Hresp not OK - set when the DMA block sees hresp not OK. Cleared by writing a one to this bit. |
| XEMACPS_RXSR_RXOVR_MASK (RXOVR) | 2 | wtc | 0x0 | Receive overrun - this bit is set if either the gem_dma RX FIFO or external RX FIFO were unable to store the receive frame due to a FIFO overflow, or if the receive status, reported by the gem_rx module to the gem_dma was not taken at end of frame. This bit is also set in DMA packet buffer mode if the packet buffer overflows. For DMA operation the buffer will be recovered if an overrun occurs. This bit is cleared by writing a one to it. |
| XEMACPS_RXSR_FRAMERX_MASK (FRAMERX) | 1 | wtc | 0x0 | Frame received - one or more frames have been received and placed in memory. Cleared by writing a one to this bit. |
| XEMACPS_RXSR_BUFFERNA_MASK (BUFFNA) | 0 | wtc | 0x0 | Buffer not available - an attempt was made to get a new buffer and the pointer indicated that it was owned by the processor. The DMA will reread the pointer each time an end of frame is received until a valid pointer is found. This bit is set following each descriptor read attempt that fails, even if consecutive pointers are unsuccessful and software has in the mean time cleared the status flag. Cleared by writing a one to this bit. |

Register ([GEM](#)) XEMACPS_ISR_OFFSET

Name XEMACPS_ISR_OFFSET
 Software Name XEMACPS_ISR
 Relative Address 0x00000024
 Absolute Address gem0: 0xE000B024
 gem1: 0xE000C024
 Width 32 bits
 Access Type mixed
 Reset Value 0x00000000

Description Interrupt Status

Register XEMACPS_ISR_OFFSET Details

Indicates an interrupt is asserted by the controller and is enabled (unmasked).

0: not asserted

1: asserted (if any bit reads as a 1, then the ethernet_int signal will be asserted to the interrupt controller)

| Field Name | Bits | Type | Reset Value | Description |
|---|-------|------|-------------|---|
| reserved | 31:27 | ro | 0x0 | Reserved, read as 0, ignored on write. |
| tsu_sec_incr | 26 | wtc | 0x0 | Enable TSU second register increment interrupt. |
| reserved | 25:18 | wtc | 0x0 | Reserved |
| partner_pg_rx | 17 | wtc | 0x0 | N/A |
| autoneg_complete | 16 | wtc | 0x0 | N/A |
| ex_intr | 15 | wtc | 0x0 | External interrupt - set when a rising edge has been detected on the ext_interrupt_in input pin. |
| XEMACPS_ISR_PAUSET X_MASK (XEMACPS_ISR_PAUSET X) | 14 | wtc | 0x0 | Pause frame transmitted- indicate a pause frame has been successfully transmitted after being initiated from the network control register or from the tx_pause control pin. |
| XEMACPS_ISR_PAUSEZ ERO_MASK (XEMACPS_ISR_PAUSEZ ERO) | 13 | wtc | 0x0 | Pause time zero - et when either the pause time register at address 0x38 decrement to zero, or when a valid pause frame is received with a zero pause quantum field. |
| XEMACPS_ISR_PAUSEN ZERO_MASK (XEMACPS_ISR_PAUSE NZERO) | 12 | wtc | 0x0 | Pause frame with non-zero pause quantum received- indicate a valid pause has been received that ha a non-zero pause quantum field. |
| XEMACPS_ISR_HREPNO K_MASK (XEMACPS_ISR_HREPNO OK) | 11 | wtc | 0x0 | Hresp not OK - et when the DMA block sees hresp not OK. |
| XEMACPS_ISR_RXOVR_ MASK (XEMACPS_ISR_RXOVR) | 10 | wtc | 0x0 | Receive overrun - set when the receive overrun status bit get set. |
| link_chng | 9 | wtc | 0x0 | N/A |
| reserved | 8 | ro | 0x0 | Reserved |
| XEMACPS_ISR_TXCOM PL_MASK (XEMACPS_ISR_TXCOM PL) | 7 | wtc | 0x0 | Transmit complete - set when a frame has been transmitted. |

| Field Name | Bits | Type | Reset Value | Description |
|---|------|--------|-------------|--|
| XEMACPS_ISR_TXEXH_MASK (XEMACPS_ISR_TXEXH) | 6 | clrond | 0x0 | Transmit frame corruption due to AHB error - set if an error occurs while midway through reading transmit frame from the AHB, including HRESP error and buffer exhausted mid frame (if the buffer run out during transmission of a frame then transmission top, FCS shall be bad and tx_er asserted). Also set in DMA packet buffer mode if single frame is too large for configured packet buffer memory size. Cleared on a read. |
| XEMACPS_ISR_RETRY_MASK (XEMACPS_ISR_RETRY) | 5 | wtc | 0x0 | Retry limit exceeded or late collision- transmit error. Late collision will only cause this status bit to be set in gigabit mode (as a retry is not attempted). |
| reserved | 4 | wtc | 0x0 | Reserved. Do not modify. |
| XEMACPS_ISR_TXUSED_MASK (XEMACPS_ISR_TXUSED) | 3 | wtc | 0x0 | TX used bit read- set when a transmit buffer descriptor is read with it used bit set. |
| XEMACPS_ISR_RXUSED_MASK (XEMACPS_ISR_RXUSED) | 2 | wtc | 0x0 | RX used bit read - set when a receive buffer descriptor is read with it used bit set. |
| XEMACPS_ISR_FRAMERX_MASK (XEMACPS_ISR_FRAMERX) | 1 | wtc | 0x0 | Receive complete- a frame has been stored in memory. |
| XEMACPS_ISR_MGMNT_MASK (XEMACPS_ISR_MGMNT) | 0 | wtc | 0x0 | Management frame sent - the PHY maintenance register has completed its operation. |

Register (GEM) XEMACPS_IER_OFFSET

| | |
|------------------|--------------------------------------|
| Name | XEMACPS_IER_OFFSET |
| Software Name | XEMACPS_IER |
| Relative Address | 0x00000028 |
| Absolute Address | gem0: 0xE000B028 gem1: 0xE000C028 |
| Width | 32 bits |
| Access Type | wo |
| Reset Value | x |
| Description | Interrupt Enable |

Register XEMACPS_IER_OFFSET Details

Enable interrupts by writing a 1 to one or more bits.

Write a 1 to enable (unmask) the interrupt.

Writing 0 has no affect on the mask bit.

When read, this register returns zero. To control interrupt masks and read status, use the interrupt status, enable, disable and mask registers together. At reset, all interrupts are disabled (masked).

| Field Name | Bits | Type | Reset Value | Description |
|---|-------|------|-------------|---|
| reserved | 31:27 | wo | x | Reserved |
| tsu_sec_incr | 26 | wo | x | Enable TSU second register increment interrupt. |
| reserved | 25:18 | wo | x | Reserved |
| partner_pg_rx | 17 | wo | x | N/A |
| autoneg_complete | 16 | wo | x | N/A |
| ex_intr | 15 | wo | x | Enable external interrupt |
| XEMACPS_IER_PAUSET X_MASK (XEMACPS_IER_PAUSET X) | 14 | wo | x | Enable pause frame transmitted interrupt. |
| XEMACPS_IER_PAUSEZ ERO_MASK (XEMACPS_IER_PAUSEZ ERO) | 13 | wo | x | Enable pause time zero interrupt. |
| XEMACPS_IER_PAUSEN ZERO_MASK (XEMACPS_IER_PAUSEN ZERO) | 12 | wo | x | Enable pause frame with non-zero pause quantum interrupt. |
| XEMACPS_IER_HRESPN OK_MASK (XEMACPS_IER_HRESP NOK) | 11 | wo | x | Enable hresp not OK interrupt |
| XEMACPS_IER_RXOVR_ MASK (XEMACPS_IER_RXOVR) | 10 | wo | x | Enable receive overrun interrupt |
| link_chng | 9 | wo | x | Enable link change interrupt |
| reserved | 8 | wo | x | Not used |
| XEMACPS_IER_TXCOMP L_MASK (XEMACP_IER_TXCOMP L) | 7 | wo | x | Enable transmit complete interrupt |
| XEMACPS_IER_TXEXH_ MASK (XEMACPS_IER_TXEXH) | 6 | wo | x | Enable transmit frame corruption due to AHB error interrupt |

| Field Name | Bits | Type | Reset Value | Description |
|--|------|------|-------------|---|
| XEMACP_IER_RETRY_MASK (XEMACP_IER_RETRY) | 5 | wo | x | Enable retry limit exceeded or late collision interrupt |
| XEMACPS_IXR_URUN_MASK (XEMACPS_IXR_URUN) | 4 | wo | x | Enable transmit buffer under run interrupt |
| XEMACP_IER_TXUSED_MASK (XEMACP_IER_TXUSED) | 3 | wo | x | Enable transmit used bit read interrupt |
| XEMACP_IER_RXUSED_MASK (XEMACP_IER_RXUSED) | 2 | wo | x | Enable receive used bit read interrupt |
| XEMACPS_IER_FRAMERX_MASK (XEMACPS_IER_FRAME RX) | 1 | wo | x | Enable receive complete interrupt |
| XEMACP_IER_MGMNT_MASK (XEMACP_IER_MGMNT) | 0 | wo | x | Enable management done interrupt |

Register ([GEM](#)) XEMACPS_IDR_OFFSET

| | |
|------------------|--------------------------------------|
| Name | XEMACPS_IDR_OFFSET |
| Software Name | XEMACPS_IDR |
| Relative Address | 0x0000002C |
| Absolute Address | gem0: 0xE000B02C gem1: 0xE000C02C |
| Width | 32 bits |
| Access Type | wo |
| Reset Value | x |
| Description | Interrupt Disable |

Register XEMACPS_IDR_OFFSET Details

Disable interrupts by applying a mask to one or more bits.

Write 1 to disable (mask) the interrupt.

Writing 0 has no affect on the mask bit.

When read, this register returns zero.

| Field Name | Bits | Type | Reset Value | Description |
|---|-------|------|-------------|--|
| reserved | 31:27 | wo | x | Reserved |
| tsu_sec_incr | 26 | wo | x | Disable TSU seconds register increment interrupt |
| reserved | 25:18 | wo | x | Reserved |
| partner_pg_rx | 17 | wo | x | N/A |
| autoneg_complete | 16 | wo | x | N/A |
| ext_intr | 15 | wo | x | Disable external interrupt |
| XEMACPS_IDR_PAUSET X_MASK (XEMACPS_IDR_PAUSET X) | 14 | wo | x | Disable pause frame transmitted interrupt |
| XEMACPS_IDR_PAUSEZ ERO_MASK (XEMACPS_IDR_PAUSEZ ERO) | 13 | wo | x | Disable pause time zero interrupt |
| XEMACPS_IDR_PAUSEN ZERO_MASK (XEMACPS_IDR_PAUSE NZERO) | 12 | wo | x | Disable pause frame with non-zero pause quantum interrupt |
| XEMACPS_IDR_HRESPN OK_MASK (XEMACPS_IDR_HRESP NOK) | 11 | wo | x | Disable hresp not OK interrupt |
| XEMACPS_IDR_RXOVR_ MASK (XEMACPS_IDR_RXOVR) | 10 | wo | x | Disable receive overrun interrupt |
| link_chng | 9 | wo | x | Disable link change interrupt |
| reserved | 8 | wo | x | Not used |
| XEMACPS_IDR_TXCOM PL_MASK (XEMACPS_IDR_TXCOM PL) | 7 | wo | x | Disable transmit complete interrupt |
| XEMACPS_IDR_TXEXH_ MASK (XEMACPS_IDR_TXEXH) | 6 | wo | x | Disable transmit frame corruption due to AHB error interrupt |
| XEMACPS_IDR_RETRY_ MASK (XEMACPS_IDR_RETRY) | 5 | wo | x | Disable retry limit exceeded or late collision interrupt |
| XEMACPS_IDR_URUN_ MASK (XEMACPS_IDR_URUN) | 4 | wo | x | Disable transmit buffer under run interrupt |
| XEMACPS_IDR_TXUSED _MASK (XEMACPS_IDR_TXUSE D) | 3 | wo | x | Disable transmit used bit read interrupt |

| Field Name | Bits | Type | Reset Value | Description |
|---|------|------|-------------|---|
| XEMACPS_IDR_RXUSED_MASK (XEMACPS_IDR_RXUSED) | 2 | wo | x | Disable receive used bit read interrupt |
| XEMACPS_IDR_FRAMERX_MASK (XEMACPS_IDR_FRAMERX) | 1 | wo | x | Disable receive complete interrupt |
| XEMACPS_IDR_MGMNT_MASK (XEMACPS_IDR_MGMNT) | 0 | wo | x | Disable management done interrupt |

Register ([GEM](#)) XEMACPS_IMR_OFFSET

| | |
|------------------|--------------------------------------|
| Name | XEMACPS_IMR_OFFSET |
| Software Name | XEMACPS_IMR |
| Relative Address | 0x00000030 |
| Absolute Address | gem0: 0xE000B030 gem1: 0xE000C030 |
| Width | 32 bits |
| Access Type | mixed |
| Reset Value | x |
| Description | Interrupt Mask Status |

Register XEMACPS_IMR_OFFSET Details

Indicates the mask state of each interrupt.

0: interrupt non masked (enabled)

1: interrupt masked (disabled), reset default

All interrupts are disabled after a module reset. The interrupt masks are individually controlled using the write-only interrupt enable and disable registers.

For test purposes there is a write-only function to the interrupt mask register that allows the bits in the interrupt status register to be set or cleared, regardless of the state of the mask register.

| Field Name | Bits | Type | Reset Value | Description |
|------------------|-------|--------|-------------|-------------|
| reserved | 31:26 | ro | x | Reserved |
| reserved | 25:18 | ro, wo | x | Reserved |
| partner_pg_rx | 17 | ro,wo | x | N/A |
| autoneg_complete | 16 | ro,wo | 0x1 | N/A |

| Field Name | Bits | Type | Reset Value | Description |
|--|------|-------|-------------|--|
| ext_intr | 15 | ro,wo | 0x1 | External interrupt mask. |
| XEMACPS_IMR_PAUSETX_MASK (XEMACPS_IMR_PAUSE TX) | 14 | ro,wo | 0x1 | Pause frame transmitted interrupt mask. |
| XEMACPS_IMR_PAUSEZERO_MASK (XEMACPS_IMR_PAUSE ZERO) | 13 | ro,wo | 0x1 | Pause time zero interrupt mask. |
| XEMACPS_IMR_PAUSENZERO_MASK (XEMACPS_IMR_PAUSE NZERO) | 12 | ro,wo | 0x1 | Pause frame with non-zero pause quantum interrupt mask. |
| XEMACPS_IMR_HRESPNOK_MASK (XEMACPS_IMR_HRESP NOK) | 11 | ro,wo | 0x1 | Hresp not OK interrupt mask. |
| XEMACPS_IMR_RXOVR_MASK (XEMACPS_IMR_RXOVR) | 10 | ro,wo | 0x1 | Receive overrun interrupt mask. |
| link_chng | 9 | ro,wo | 0x1 | Link change interrupt mask. |
| reserved | 8 | ro,wo | 0x1 | Not used |
| XEMACPS_IMR_TXCOMPLETE_MASK (XEMACPS_IMR_TXCO MPL) | 7 | ro,wo | 0x1 | Transmit complete interrupt mask. |
| XEMACPS_IMR_TXEXH_MASK (XEMACPS_IMR_TXEXH) | 6 | ro,wo | 0x1 | Transmit frame corruption due to AHB error interrupt |
| XEMACPS_IMR_RETRY_MASK (XEMACPS_IMR_RETRY) | 5 | ro,wo | 0x1 | Retry limit exceeded or late collision (gigabit mode only) |
| XEMACPS_IMR_URUN_MASK (XEMACPS_IMR_URUN) | 4 | ro,wo | 0x1 | Transmit buffer under run interrupt mask. |
| XEMACPS_IMR_TXUSED_MASK (XEMACPS_IMR_TXUSE D) | 3 | ro,wo | 0x1 | Transmit used bit read interrupt mask. |
| XEMACPS_IMR_RXUSED_MASK (XEMACPS_IMR_RXUSE D) | 2 | ro,wo | 0x1 | Receive used bit read interrupt mask. |

| Field Name | Bits | Type | Reset Value | Description |
|---|------|-------|-------------|----------------------------------|
| XEMACPS_IMR_FRAME_RX_MASK (XEMACPS_IMR_FRAME_RX) | 1 | ro,wo | 0x1 | Receive complete interrupt mask. |
| XEMACPS_IMR_MGMN_T_MASK (XEMACPS_IMR_MGMN_T) | 0 | ro,wo | 0x1 | Management done interrupt mask. |

Register ([GEM](#)) XEMACPS_PHYMNTNC_OFFSET

| | |
|------------------|--------------------------------------|
| Name | XEMACPS_PHYMNTNC_OFFSET |
| Software Name | XEMACPS_PHYMNTNC |
| Relative Address | 0x00000034 |
| Absolute Address | gem0: 0xE000B034 gem1: 0xE000C034 |
| Width | 32 bits |
| Access Type | rw |
| Reset Value | 0x00000000 |
| Description | PHY Maintenance |

Register XEMACPS_PHYMNTNC_OFFSET Details

The PHY maintenance register is implemented as a shift register. Writing to the register starts a shift operation, which is signaled as complete when bit-2 is set in the network status register. It takes about 2000 pclk cycles to complete, when MDC is set for pclk divide by 32 in the network configuration register. An interrupt is generated upon completion. During this time, the MSB of the register is output on the MDIO pin and the LSB updated from the MDIO pin with each MDC cycle. This causes transmission of a PHY management frame on MDIO. See Section 22.2.4.5 of the IEEE 802.3 standard. Reading during the shift operation will return the current contents of the shift register. At the end of management operation, the bits will have shifted back to their original locations. For a read operation, the data bits will be updated with data read from the PHY. It is important to write the correct values to the register to ensure a valid PHY management frame is produced.

| Field Name | Bits | Type | Reset Value | Description |
|----------------------------------|-------|------|-------------|---|
| reserved | 31 | rw | 0x0 | Must be written with 0. |
| clause_22 | 30 | rw | 0x0 | Must be written to 1 for Clause 22 operation. Check your PHY's spec to see if it is clause 22 or clause 45 compliant. |
| XEMACPS_PHYMNTNC_OP_MASK (OP) | 29:28 | rw | 0x0 | Operation. 10 is read. 01 is write. |

| Field Name | Bits | Type | Reset Value | Description |
|-----------------------------------|-------|------|-------------|--|
| XEMACPS_PHYMNTNC_ADDR_MASK (ADDR) | 27:23 | rw | 0x0 | PHY address. |
| XEMACPS_PHYMNTNC_REG_MASK (REG) | 22:18 | rw | 0x0 | Register address - specifies the register in the PHY to access. |
| must_10 | 17:16 | rw | 0x0 | Must be written to 10. |
| XEMACPS_PHYMNTNC_DATA_MASK (DATA) | 15:0 | rw | 0x0 | For a write operation this is written with the data to be written to the PHY. After a read operation this contains the data read from the PHY. |

Register ([GEM](#)) XEMACPS_RXPAUSE_OFFSET

| | |
|------------------|--------------------------------------|
| Name | XEMACPS_RXPAUSE_OFFSET |
| Software Name | XEMACPS_RXPAUSE |
| Relative Address | 0x00000038 |
| Absolute Address | gem0: 0xE000B038 gem1: 0xE000C038 |
| Width | 32 bits |
| Access Type | ro |
| Reset Value | 0x00000000 |
| Description | Received Pause Quantum |

Register XEMACPS_RXPAUSE_OFFSET Details

| Field Name | Bits | Type | Reset Value | Description |
|------------|-------|------|-------------|--|
| reserved | 31:16 | ro | 0x0 | Reserved, read as 0, ignored on write. |
| rx_pauseq | 15:0 | ro | 0x0 | Received pause quantum - stores the current value of the received pause quantum register which is decremented every 512 bit times. |

Register ([GEM](#)) XEMACPS_TXPAUSE_OFFSET

| | |
|------------------|--------------------------------------|
| Name | XEMACPS_TXPAUSE_OFFSET |
| Software Name | XEMACPS_TXPAUSE |
| Relative Address | 0x0000003C |
| Absolute Address | gem0: 0xE000B03C gem1: 0xE000C03C |
| Width | 32 bits |
| Access Type | rw |

Reset Value 0x0000FFFF
 Description Transmit Pause Quantum

Register XEMACPS_TXPAUSE_OFFSET Details

| Field Name | Bits | Type | Reset Value | Description |
|------------|-------|------|-------------|---|
| reserved | 31:16 | rw | 0x0 | Reserved, read as 0, ignored on write. |
| tx_pauseq | 15:0 | rw | 0xFFFF | Transmit pause quantum - written with the pause quantum value for pause frame transmission. |

Register (GEM) XEMACPS_HASHL_OFFSET

Name XEMACPS_HASHL_OFFSET
 Software Name XEMACPS_HASHL
 Relative Address 0x00000080
 Absolute Address gem0: 0xE000B080
 gem1: 0xE000C080
 Width 32 bits
 Access Type rw
 Reset Value 0x00000000
 Description Hash Register Bottom [31:0]

Register XEMACPS_HASHL_OFFSET Details

The unicast hash enable and the multicast hash enable bits in the network configuration register enable the reception of hash matched frames.

| Field Name | Bits | Type | Reset Value | Description |
|------------|------|------|-------------|---|
| | 31:0 | rw | 0x0 | The first 32 bits of the hash address register. |

Register (GEM) XEMACPS_HASHH_OFFSET

Name XEMACPS_HASHH_OFFSET
 Software Name XEMACPS_HASHH
 Relative Address 0x00000084
 Absolute Address gem0: 0xE000B084
 gem1: 0xE000C084
 Width 32 bits
 Access Type rw
 Reset Value 0x00000000

Description Hash Register Top [63:32]

Register XEMACPS_HASHH_OFFSET Details

The unicast hash enable and the multicast hash enable bits in the network configuration register enable the reception of hash matched frames.

| Field Name | Bits | Type | Reset Value | Description |
|------------|------|------|-------------|---|
| | 31:0 | rw | 0x0 | The remaining 32 bits of the hash address register. |

Register (GEM) XEMACPS_LADDR1L_OFFSET

Name XEMACPS_LADDR1L_OFFSET
 Software Name XEMACPS_LADDR1L
 Relative Address 0x00000088
 Absolute Address gem0: 0xE000B088
 gem1: 0xE000C088
 Width 32 bits
 Access Type rw
 Reset Value 0x00000000
 Description Specific Address 1 Bottom [31:0]

Register XEMACPS_LADDR1L_OFFSET Details

| Field Name | Bits | Type | Reset Value | Description |
|------------|------|------|-------------|--|
| | 31:0 | rw | 0x0 | Least significant 32 bits of the destination address, that is bits 31:0. Bit zero indicates whether the address is multicast or unicast and corresponds to the least significant bit of the first byte received. |

Register (GEM) XEMACPS_LADDR1H_OFFSET

Name XEMACPS_LADDR1H_OFFSET
 Software Name XEMACPS_LADDR1H
 Relative Address 0x0000008C
 Absolute Address gem0: 0xE000B08C
 gem1: 0xE000C08C
 Width 32 bits
 Access Type mixed
 Reset Value 0x00000000

Description Specific Address 1 Top [47:32]

Register XEMACPS_LADDR1H_OFFSET Details

| Field Name | Bits | Type | Reset Value | Description |
|------------|-------|------|-------------|---|
| reserved | 31:16 | ro | 0x0 | Reserved, read as 0, ignored on write |
| addr_msbs | 15:0 | rw | 0x0 | Specific address 1. The most significant bits of the destination address, that is bits 47:32. |

Register ([GEM](#)) XEMACPS_LADDR2L_OFFSET

Name XEMACPS_LADDR2L_OFFSET
 Software Name XEMACPS_LADDR2L
 Relative Address 0x00000090
 Absolute Address gem0: 0xE000B090
 gem1: 0xE000C090
 Width 32 bits
 Access Type rw
 Reset Value 0x00000000
 Description Specific Address 2 Bottom [31:0]

Register XEMACPS_LADDR2L_OFFSET Details

| Field Name | Bits | Type | Reset Value | Description |
|------------|------|------|-------------|--|
| | 31:0 | rw | 0x0 | Least significant 32 bits of the destination address, that is bits 31:0. Bit zero indicates whether the address is multicast or unicast and corresponds to the least significant bit of the first byte received. |

Register ([GEM](#)) XEMACPS_LADDR2H_OFFSET

Name XEMACPS_LADDR2H_OFFSET
 Software Name XEMACPS_LADDR2H
 Relative Address 0x00000094
 Absolute Address gem0: 0xE000B094
 gem1: 0xE000C094
 Width 32 bits
 Access Type mixed
 Reset Value 0x00000000
 Description Specific Address 2 Top [47:32]

Register XEMACPS_LADDR2H_OFFSET Details

| Field Name | Bits | Type | Reset Value | Description |
|------------|-------|------|-------------|---|
| reserved | 31:16 | ro | 0x0 | Reserved, read as 0, ignored on write |
| addr_msbs | 15:0 | rw | 0x0 | Specific address 2. The most significant bits of the destination address, that is bits 47:32. |

Register ([GEM](#)) XEMACPS_LADDR3L_OFFSET

| | |
|------------------|--------------------------------------|
| Name | XEMACPS_LADDR3L_OFFSET |
| Software Name | XEMACPS_LADDR3L |
| Relative Address | 0x00000098 |
| Absolute Address | gem0: 0xE000B098 gem1: 0xE000C098 |
| Width | 32 bits |
| Access Type | rw |
| Reset Value | 0x00000000 |
| Description | Specific Address 3 Bottom [31:0] |

Register XEMACPS_LADDR3L_OFFSET Details

| Field Name | Bits | Type | Reset Value | Description |
|------------|------|------|-------------|--|
| | 31:0 | rw | 0x0 | Least significant 32 bits of the destination address, that is bits 31:0. Bit zero indicates whether the address is multicast or unicast and corresponds to the least significant bit of the first byte received. |

Register ([GEM](#)) XEMACPS_LADDR3H_OFFSET

| | |
|------------------|--------------------------------------|
| Name | XEMACPS_LADDR3H_OFFSET |
| Software Name | XEMACPS_LADDR3H |
| Relative Address | 0x0000009C |
| Absolute Address | gem0: 0xE000B09C gem1: 0xE000C09C |
| Width | 32 bits |
| Access Type | mixed |
| Reset Value | 0x00000000 |
| Description | Specific Address 3 Top [47:32] |

Register XEMACPS_LADDR3H_OFFSET Details

| Field Name | Bits | Type | Reset Value | Description |
|------------|-------|------|-------------|---|
| reserved | 31:16 | ro | 0x0 | Reserved, read as 0, ignored on write |
| addr_msbs | 15:0 | rw | 0x0 | Specific address 3. The most significant bits of the destination address, that is bits 47:32. |

Register (GEM) XEMACPS_LADDR4L_OFFSET

| | |
|------------------|--------------------------------------|
| Name | XEMACPS_LADDR4L_OFFSET |
| Software Name | XEMACPS_LADDR4L |
| Relative Address | 0x000000A0 |
| Absolute Address | gem0: 0xE000B0A0 gem1: 0xE000C0A0 |
| Width | 32 bits |
| Access Type | rw |
| Reset Value | 0x00000000 |
| Description | Specific Address 4 Bottom [31:0] |

Register XEMACPS_LADDR4L_OFFSET Details

| Field Name | Bits | Type | Reset Value | Description |
|------------|------|------|-------------|--|
| | 31:0 | rw | 0x0 | Least significant 32 bits of the destination address, that is bits 31:0. Bit zero indicates whether the address is multicast or unicast and corresponds to the least significant bit of the first byte received. |

Register (GEM) XEMACPS_LADDR4H_OFFSET

| | |
|------------------|--------------------------------------|
| Name | XEMACPS_LADDR4H_OFFSET |
| Software Name | XEMACPS_LADDR4H |
| Relative Address | 0x000000A4 |
| Absolute Address | gem0: 0xE000B0A4 gem1: 0xE000C0A4 |
| Width | 32 bits |
| Access Type | mixed |
| Reset Value | 0x00000000 |
| Description | Specific Address 4 Top [47:32] |

Register XEMACPS_LADDR4H_OFFSET Details

| Field Name | Bits | Type | Reset Value | Description |
|------------|-------|------|-------------|---|
| reserved | 31:16 | ro | 0x0 | Reserved, read as 0, ignored on write |
| addr_msbs | 15:0 | rw | 0x0 | Specific address 4. The most significant bits of the destination address, that is bits 47:32. |

Register (GEM) XEMACPS_MATCH1_OFFSET

| | |
|------------------|--------------------------------------|
| Name | XEMACPS_MATCH1_OFFSET |
| Software Name | XEMACPS_MATCH1 |
| Relative Address | 0x000000A8 |
| Absolute Address | gem0: 0xE000B0A8 gem1: 0xE000C0A8 |
| Width | 32 bits |
| Access Type | mixed |
| Reset Value | 0x00000000 |
| Description | Type ID Match 1 |

Register XEMACPS_MATCH1_OFFSET Details

| Field Name | Bits | Type | Reset Value | Description |
|----------------|-------|------|-------------|--|
| copy_en | 31 | rw | 0x0 | Enable copying of type ID match 1 matched frames |
| reserved | 30:16 | ro | 0x0 | Reserved, read as 0, ignored on write |
| type_id_match1 | 15:0 | rw | 0x0 | Type ID match 1. For use in comparisons with received frames type ID/length field. |

Register (GEM) XEMACPS_MATCH2_OFFSET

| | |
|------------------|--------------------------------------|
| Name | XEMACPS_MATCH2_OFFSET |
| Software Name | XEMACPS_MATCH2 |
| Relative Address | 0x000000AC |
| Absolute Address | gem0: 0xE000B0AC gem1: 0xE000C0AC |
| Width | 32 bits |
| Access Type | mixed |
| Reset Value | 0x00000000 |
| Description | Type ID Match 2 |

Register XEMACPS_MATCH2_OFFSET Details

| Field Name | Bits | Type | Reset Value | Description |
|----------------|-------|------|-------------|--|
| copy_en | 31 | rw | 0x0 | Enable copying of type ID match 2 matched frames |
| reserved | 30:16 | ro | 0x0 | Reserved, read as 0, ignored on write |
| type_id_match2 | 15:0 | rw | 0x0 | Type ID match 2. For use in comparisons with received frames type ID/length field. |

Register ([GEM](#)) XEMACPS_MATCH3_OFFSET

| | |
|------------------|--------------------------------------|
| Name | XEMACPS_MATCH3_OFFSET |
| Software Name | XEMACPS_MATCH3 |
| Relative Address | 0x000000B0 |
| Absolute Address | gem0: 0xE000B0B0 gem1: 0xE000C0B0 |
| Width | 32 bits |
| Access Type | mixed |
| Reset Value | 0x00000000 |
| Description | Type ID Match 3 |

Register XEMACPS_MATCH3_OFFSET Details

| Field Name | Bits | Type | Reset Value | Description |
|----------------|-------|------|-------------|--|
| copy_en | 31 | rw | 0x0 | Enable copying of type ID match 3 matched frames |
| reserved | 30:16 | ro | 0x0 | Reserved, read as 0, ignored on write |
| type_id_match3 | 15:0 | rw | 0x0 | Type ID match 3. For use in comparisons with received frames type ID/length field. |

Register ([GEM](#)) XEMACPS_MATCH4_OFFSET

| | |
|------------------|--------------------------------------|
| Name | XEMACPS_MATCH4_OFFSET |
| Software Name | XEMACPS_MATCH4 |
| Relative Address | 0x000000B4 |
| Absolute Address | gem0: 0xE000B0B4 gem1: 0xE000C0B4 |
| Width | 32 bits |
| Access Type | mixed |
| Reset Value | 0x00000000 |

Description Type ID Match 4

Register XEMACPS_MATCH4_OFFSET Details

| Field Name | Bits | Type | Reset Value | Description |
|----------------|-------|------|-------------|--|
| copy_en | 31 | rw | 0x0 | Enable copying of type ID match 4 matched frames |
| reserved | 30:16 | ro | 0x0 | Reserved, read as 0, ignored on write |
| type_id_match4 | 15:0 | rw | 0x0 | Type ID match 4. For use in comparisons with received frames type ID/length field. |

Register (GEM) wake_on_lan

Name wake_on_lan
 Relative Address 0x000000B8
 Absolute Address gem0: 0xE000B0B8
 gem1: 0xE000C0B8
 Width 32 bits
 Access Type mixed
 Reset Value 0x00000000
 Description Wake on LAN Register

Register wake_on_lan Details

| Field Name | Bits | Type | Reset Value | Description |
|-------------------|-------|------|-------------|--|
| reserved | 31:20 | ro | 0x0 | Reserved - read 0, ignored when written |
| multi_hash_en | 19 | rw | 0x0 | Wake on LAN multicast hash event enable. When set multicast hash events will cause the wol output to be asserted. |
| spec_addr_reg1_en | 18 | rw | 0x0 | Wake on LAN specific address register 1 event enable. When set specific address 1 events will cause the wol output to be asserted. |
| arp_req_en | 17 | rw | 0x0 | Wake on LAN ARP request event enable. When set ARP request events will cause the wol output to be asserted. |
| magic_pkt_en | 16 | rw | 0x0 | Wake on LAN magic packet event enable. When set magic packet events will cause the wol output to be asserted. |
| arp_req_ip_addr | 15:0 | rw | 0x0 | Wake on LAN ARP request IP address. Written to define the least significant 16 bits of the target IP address that is matched to generate a Wake on LAN event. A value of zero will not generate an event, even if this is matched by the received frame. |

Register ([GEM](#)) XEMACPS_STRETCH_OFFSET

| | |
|------------------|--------------------------------------|
| Name | XEMACPS_STRETCH_OFFSET |
| Software Name | XEMACPS_STRETCH |
| Relative Address | 0x000000BC |
| Absolute Address | gem0: 0xE000B0BC gem1: 0xE000C0BC |
| Width | 32 bits |
| Access Type | mixed |
| Reset Value | 0x00000000 |
| Description | IPG stretch register |

Register XEMACPS_STRETCH_OFFSET Details

| Field Name | Bits | Type | Reset Value | Description |
|-------------|-------|------|-------------|--|
| reserved | 31:16 | ro | 0x0 | Reserved, read as 0, ignored on write. |
| ipg_stretch | 15:0 | rw | 0x0 | Bits 7:0 are multiplied with the previously transmitted frame length (including preamble) bits 15:8 +1 divide the frame length. If the resulting number is greater than 96 and bit 28 is set in the network configuration register then the resulting number is used for the transmit inter-packet-gap. 1 is added to bits 15:8 to prevent a divide by zero. |

Register ([GEM](#)) stacked_vlan

| | |
|------------------|--------------------------------------|
| Name | stacked_vlan |
| Relative Address | 0x000000C0 |
| Absolute Address | gem0: 0xE000B0C0 gem1: 0xE000C0C0 |
| Width | 32 bits |
| Access Type | mixed |
| Reset Value | 0x00000000 |
| Description | Stacked VLAN Register |

Register stacked_vlan Details

| Field Name | Bits | Type | Reset Value | Description |
|-----------------|------|------|-------------|-------------------------------------|
| stacked_vlan_en | 31 | rw | 0x0 | Enable Stacked VLAN processing mode |

| Field Name | Bits | Type | Reset Value | Description |
|--------------------|-------|------|-------------|--|
| reserved | 30:16 | ro | 0x0 | Reserved, read as 0, ignored on write. |
| user_def_vlan_type | 15:0 | rw | 0x0 | User defined VLAN_TYPE field. When Stacked VLAN is enabled, the first VLAN tag in a received frame will only be accepted if the VLAN type field is equal to this user defined VLAN_TYPE OR equal to the standard VLAN type (0x8100). Note that the second VLAN tag of a Stacked VLAN packet will only be matched correctly if its VLAN_TYPE field equals 0x8100. |

Register (GEM) tx_pfc_pause

| | |
|------------------|------------------------------------|
| Name | tx_pfc_pause |
| Relative Address | 0x000000C4 |
| Absolute Address | gem0: 0xE00B0C4 gem1: 0xE00C0C4 |
| Width | 32 bits |
| Access Type | mixed |
| Reset Value | 0x00000000 |
| Description | Transmit PFC Pause Register |

Register tx_pfc_pause Details

| Field Name | Bits | Type | Reset Value | Description |
|----------------|-------|------|-------------|--|
| reserved | 31:16 | ro | 0x0 | Reserved, read as 0, ignored on write. |
| pauseq_sel | 15:8 | rw | 0x0 | If bit 17 of the network control register is written with a one then for each entry equal to zero in the Transmit PFC Pause Register[15:8], the PFC pause frame's pause quantum field associated with that entry will be taken from the transmit pause quantum register. For each entry equal to one in the Transmit PFC Pause Register [15:8], the pause quantum associated with that entry will be zero. |
| pri_en_vec_val | 7:0 | rw | 0x0 | If bit 17 of the network control register is written with a one then the priority enable vector of the PFC priority based pause frame will be set equal to the value stored in this register [7:0]. |

Register (GEM) spec_addr1_mask_bot

| | |
|------------------|------------------------------------|
| Name | spec_addr1_mask_bot |
| Relative Address | 0x000000C8 |
| Absolute Address | gem0: 0xE00B0C8 gem1: 0xE00C0C8 |

| | |
|-------------|---------------------------------------|
| Width | 32 bits |
| Access Type | rw |
| Reset Value | 0x00000000 |
| Description | Specific Address Mask 1 Bottom [31:0] |

Register spec_addr1_mask_bot Details

| Field Name | Bits | Type | Reset Value | Description |
|---------------|------|------|-------------|---|
| mask_bits_bot | 31:0 | rw | 0x0 | Setting a bit to one masks the corresponding bit in the specific address 1 register |

Register ([GEM](#)) spec_addr1_mask_top

| | |
|------------------|--------------------------------------|
| Name | spec_addr1_mask_top |
| Relative Address | 0x000000CC |
| Absolute Address | gem0: 0xE000B0CC gem1: 0xE000C0CC |
| Width | 32 bits |
| Access Type | mixed |
| Reset Value | 0x00000000 |
| Description | Specific Address Mask 1 Top [47:32] |

Register spec_addr1_mask_top Details

| Field Name | Bits | Type | Reset Value | Description |
|---------------|-------|------|-------------|---|
| reserved | 31:16 | ro | 0x0 | Reserved, read as 0, ignored on write. |
| mask_bits_top | 15:0 | rw | 0x0 | Setting a bit to one masks the corresponding bit in the specific address 1 register |

Register ([GEM](#)) module_id

| | |
|------------------|--------------------------------------|
| Name | module_id |
| Relative Address | 0x000000FC |
| Absolute Address | gem0: 0xE000B0FC gem1: 0xE000C0FC |
| Width | 32 bits |
| Access Type | ro |
| Reset Value | 0x00020118 |
| Description | Module ID |

Register module_id Details

This register indicates a Cadence module identification number and module revision. The value of this register is read only as defined by `gem_revision_reg_value`. With GEM p23, it is 0x00020118.

| Field Name | Bits | Type | Reset Value | Description |
|------------|-------|------|-------------|--|
| module_id | 31:16 | ro | 0x2 | Module identification number - for the GEM, this value is fixed at 0x0002. |
| module_rev | 15:0 | ro | 0x118 | Module revision - fixed byte value specific to the revision of the design which is incremented after each release of the IP. Corresponds to Zynq having GEM p23. |

Register ([GEM](#)) XEMACPS_OCTTXL_OFFSET

| | |
|------------------|---|
| Name | XEMACPS_OCTTXL_OFFSET |
| Software Name | XEMACPS_OCTTXL |
| Relative Address | 0x00000100 |
| Absolute Address | gem0: 0xE000B100 gem1: 0xE000C100 |
| Width | 32 bits |
| Access Type | ro |
| Reset Value | 0x00000000 |
| Description | Octets transmitted [31:0] (in frames without error) |

Register XEMACPS_OCTTXL_OFFSET Details

Bits 31:0 should be read prior to bits 47:32 to ensure reliable operation. In statistics register block. Is reset to zero on a read and stick at all ones when it counts to its maximum value. It should be read frequently enough to prevent loss of data.

For test purposes, it may be written by setting bit 7 (Write Enable) in the network control register. Setting bit 6 (increment statistics) in the network control register causes all the statistics registers to increment by one, again for test purposes.

Once a statistics register has been read, it is automatically cleared.

| Field Name | Bits | Type | Reset Value | Description |
|---------------|------|------|-------------|--|
| octets_tx_bot | 31:0 | ro | 0x0 | Transmitted octets in frame without errors [31:0]. The number of octets transmitted in valid frames of any type. This counter is 48-bits, and is read through two registers. This count does not include octets from automatically generated pause frames. |

Register ([GEM](#)) XEMACPS_OCTTXH_OFFSET

| | |
|------------------|--|
| Name | XEMACPS_OCTTXH_OFFSET |
| Software Name | XEMACPS_OCTTXH |
| Relative Address | 0x00000104 |
| Absolute Address | gem0: 0xE000B104 gem1: 0xE000C104 |
| Width | 32 bits |
| Access Type | ro |
| Reset Value | 0x00000000 |
| Description | Octets transmitted [47:32] (in frames without error) |

Register XEMACPS_OCTTXH_OFFSET Details

Bits 31:0 should be read prior to bits 47:32 to ensure reliable operation. In statistics register block. Is reset to zero on a read and stick at all ones when it counts to its maximum value. It should be read frequently enough to prevent loss of data.

For test purposes, it may be written by setting bit 7 (Write Enable) in the network control register. Setting bit 6 (increment statistics) in the network control register causes all the statistics registers to increment by one, again for test purposes.

Once a statistics register has been read, it is automatically cleared.

| Field Name | Bits | Type | Reset Value | Description |
|---------------|-------|------|-------------|---|
| reserved | 31:16 | ro | 0x0 | Reserved, read as 0, ignored on write. |
| octets_tx_top | 15:0 | ro | 0x0 | Transmitted octets in frame without errors [47:32]. The number of octets transmitted in valid frames of any type. This counter is 48-bits, and is read through two registers. This count does not include octets from automatically generated pause frames. |

Register ([GEM](#)) XEMACPS_TXCNT_OFFSET

| | |
|------------------|--------------------------------------|
| Name | XEMACPS_TXCNT_OFFSET |
| Software Name | XEMACPS_TXCNT |
| Relative Address | 0x00000108 |
| Absolute Address | gem0: 0xE000B108 gem1: 0xE000C108 |
| Width | 32 bits |
| Access Type | ro |
| Reset Value | 0x00000000 |

Description Frames Transmitted

Register XEMACPS_TXCNT_OFFSET Details

Statistical counter for Frames transmitted without an error and exclude pause frames.

NOTES for ALL Statistical registers for Frames Transferred:

The a statistical counter is read by software, it is cleared to zero by the hardware. When a counter reaches its maximum value, it stops counting and is read with all 1s. The statistical counters must be read frequently enough if data loss is to be prevented.

For test purposes, all of the statistical counters may be written to (not just read) by setting bit 7 (wren_stat_regs) in the network control register. Also for test purposes, all of the statistical counters can be incremented (by one) by writing a 1 to bit 6 (incr_stat_regs) of the network control register.

| Field Name | Bits | Type | Reset Value | Description |
|------------|------|------|-------------|---|
| | 31:0 | ro | 0x0 | Frames transmitted without error. A 32 bit register counting the number of frames successfully transmitted, i.e., no under run and not too many retries. Excludes pause frames. |

Register (GEM) XEMACPS_TXBCCNT_OFFSET

Name XEMACPS_TXBCCNT_OFFSET
 Software Name XEMACPS_TXBCCNT
 Relative Address 0x0000010C
 Absolute Address gem0: 0xE000B10C
 gem1: 0xE000C10C
 Width 32 bits
 Access Type ro
 Reset Value 0x00000000
 Description Broadcast frames Tx

Register XEMACPS_TXBCCNT_OFFSET Details

Statistical counter for Broadcast Frames transmitted without an error and exclude pause frames. Refer to the FRAMES_TX register for additional information.

| Field Name | Bits | Type | Reset Value | Description |
|------------|------|------|-------------|---|
| | 31:0 | ro | 0x0 | Broadcast frames transmitted without error. A 32 bit register counting the number of broadcast frames successfully transmitted without error, i.e., no under run and not too many retries. Excludes pause frames. |

Register ([GEM](#)) XEMACPS_TXMCCNT_OFFSET

| | |
|------------------|--------------------------------------|
| Name | XEMACPS_TXMCCNT_OFFSET |
| Software Name | XEMACPS_TXMCCNT |
| Relative Address | 0x00000110 |
| Absolute Address | gem0: 0xE000B110 gem1: 0xE000C110 |
| Width | 32 bits |
| Access Type | ro |
| Reset Value | 0x00000000 |
| Description | Multicast frames Tx |

Register XEMACPS_TXMCCNT_OFFSET Details

Statistical counter for Multicast Frames transmitted without an error and exclude pause frames. Refer to the FRAMES_TX register for additional information.

| Field Name | Bits | Type | Reset Value | Description |
|------------|------|------|-------------|---|
| | 31:0 | ro | 0x0 | Multicast frames transmitted without error. A 32 bit register counting the number of multicast frames successfully transmitted without error, i.e., no under run and not too many retries. Excludes pause frames. |

Register ([GEM](#)) XEMACPS_TXPAUSECNT_OFFSET

| | |
|------------------|--------------------------------------|
| Name | XEMACPS_TXPAUSECNT_OFFSET |
| Software Name | XEMACPS_TXPAUSECNT |
| Relative Address | 0x00000114 |
| Absolute Address | gem0: 0xE000B114 gem1: 0xE000C114 |
| Width | 32 bits |
| Access Type | ro |
| Reset Value | 0x00000000 |
| Description | Pause frames Tx |

Register XEMACPS_TXPAUSECNT_OFFSET Details

Statistical counter for Pause Frames transmitted without an error and not sent through the FIFO interface. Refer to the FRAMES_TX register for additional information.

| Field Name | Bits | Type | Reset Value | Description |
|-----------------|-------|------|-------------|--|
| reserved | 31:16 | ro | 0x0 | Reserved, read as 0, ignored on write. |
| pause_frames_tx | 15:0 | ro | 0x0 | Transmitted pause frames - a 16 bit register counting the number of pause frames transmitted. Only pause frames triggered by the register interface or through the external pause pins are counted as pause frames. Pause frames received through the external FIFO interface are counted in the frames transmitted counter. |

Register (GEM) XEMACPS_TX64CNT_OFFSET

| | |
|------------------|--------------------------------------|
| Name | XEMACPS_TX64CNT_OFFSET |
| Software Name | XEMACPS_TX64CNT |
| Relative Address | 0x00000118 |
| Absolute Address | gem0: 0xE000B118 gem1: 0xE000C118 |
| Width | 32 bits |
| Access Type | ro |
| Reset Value | 0x00000000 |
| Description | Frames Tx, 64-byte length |

Register XEMACPS_TX64CNT_OFFSET Details

Statistical counter of frames of 64 bytes that are transmitted without error. Does not include pause frames. Refer to the FRAMES_TX register for additional information.

| Field Name | Bits | Type | Reset Value | Description |
|------------|------|------|-------------|---|
| | 31:0 | ro | 0x0 | 64 byte frames transmitted without error. A 32 bit register counting the number of 64 byte frames successfully transmitted without error, i.e., no under run and not too many retries. Excludes pause frames. |

Register (GEM) XEMACPS_TX65CNT_OFFSET

| | |
|------------------|--------------------------------------|
| Name | XEMACPS_TX65CNT_OFFSET |
| Software Name | XEMACPS_TX65CNT |
| Relative Address | 0x0000011C |
| Absolute Address | gem0: 0xE000B11C gem1: 0xE000C11C |
| Width | 32 bits |
| Access Type | ro |

Reset Value 0x00000000
 Description Frames Tx, 65 to 127-byte length

Register XEMACPS_TX65CNT_OFFSET Details

Statistical counter of frames of 65 to 127 bytes that are transmitted without error. Does not include pause frames. Refer to the FRAMES_TX register for additional information.

| Field Name | Bits | Type | Reset Value | Description |
|------------|------|------|-------------|--|
| | 31:0 | ro | 0x0 | 65 to127 byte frames transmitted without error. A 32 bit register counting the number of 65 to127 byte frames successfully transmitted without error, i.e., no under run and not too many retries. |

Register (GEM) XEMACPS_TX128CNT_OFFSET

Name XEMACPS_TX128CNT_OFFSET
 Software Name XEMACPS_TX128CNT
 Relative Address 0x00000120
 Absolute Address gem0: 0xE000B120
 gem1: 0xE000C120
 Width 32 bits
 Access Type ro
 Reset Value 0x00000000
 Description Frames Tx, 128 to 255-byte length

Register XEMACPS_TX128CNT_OFFSET Details

Statistical counter of frames of 128 to 255 bytes that are transmitted without error. Does not include pause frames. Refer to the FRAMES_TX register for additional information.

| Field Name | Bits | Type | Reset Value | Description |
|------------|------|------|-------------|--|
| | 31:0 | ro | 0x0 | 128 to 255 byte frames transmitted without error. A 32 bit register counting the number of 128 to 255 byte frames successfully transmitted without error, i.e., no under run and not too many retries. |

Register (GEM) XEMACPS_TX256CNT_OFFSET

Name XEMACPS_TX256CNT_OFFSET
 Software Name XEMACPS_TX256CNT
 Relative Address 0x00000124

| | |
|------------------|--------------------------------------|
| Absolute Address | gem0: 0xE000B124 gem1: 0xE000C124 |
| Width | 32 bits |
| Access Type | ro |
| Reset Value | 0x00000000 |
| Description | Frames Tx, 256 to 511-byte length |

Register XEMACPS_TX256CNT_OFFSET Details

Statistical counter of frames of 256 to 511 bytes that are transmitted without error. Does not include pause frames. Refer to the FRAMES_TX register for additional information.

| Field Name | Bits | Type | Reset Value | Description |
|------------|------|------|-------------|--|
| | 31:0 | ro | 0x0 | 256 to 511 byte frames transmitted without error. A 32 bit register counting the number of 256 to 511 byte frames successfully transmitted without error, i.e., no under run and not too many retries. |

Register ([GEM](#)) XEMACPS_TX512CNT_OFFSET

| | |
|------------------|--------------------------------------|
| Name | XEMACPS_TX512CNT_OFFSET |
| Software Name | XEMACPS_TX512CNT |
| Relative Address | 0x00000128 |
| Absolute Address | gem0: 0xE000B128 gem1: 0xE000C128 |
| Width | 32 bits |
| Access Type | ro |
| Reset Value | 0x00000000 |
| Description | Frames Tx, 512 to 1023-byte length |

Register XEMACPS_TX512CNT_OFFSET Details

Statistical counter of frames of 512 to 1023 bytes that are transmitted without error. Does not include pause frames. Refer to the FRAMES_TX register for additional information.

| Field Name | Bits | Type | Reset Value | Description |
|------------|------|------|-------------|--|
| | 31:0 | ro | 0x0 | 512 to 1023 byte frames transmitted without error. A 32 bit register counting the number of 512 to 1023 byte frames successfully transmitted without error, i.e., no under run and not too many retries. |

Register ([GEM](#)) XEMACPS_TX1024CNT_OFFSET

| | |
|------------------|--------------------------------------|
| Name | XEMACPS_TX1024CNT_OFFSET |
| Software Name | XEMACPS_TX1024CNT |
| Relative Address | 0x0000012C |
| Absolute Address | gem0: 0xE000B12C gem1: 0xE000C12C |
| Width | 32 bits |
| Access Type | ro |
| Reset Value | 0x00000000 |
| Description | Frame Tx, 1024 to 1518-byte length |

Register XEMACPS_TX1024CNT_OFFSET Details

Statistical counter of frames of 1024 to 1518 bytes that are transmitted without error. Does not include pause frames. Refer to the FRAMES_TX register for additional information.

| Field Name | Bits | Type | Reset Value | Description |
|------------|------|------|-------------|--|
| | 31:0 | ro | 0x0 | 1024 to 1518 byte frames transmitted without error. A 32 bit register counting the number of 1024 to 1518 byte frames successfully transmitted without error, i.e., no under run and not too many retries. |

Register ([GEM](#)) XEMACPS_TXURUNCNT_OFFSET

| | |
|------------------|--------------------------------------|
| Name | XEMACPS_TXURUNCNT_OFFSET |
| Software Name | XEMACPS_TXURUNCNT |
| Relative Address | 0x00000134 |
| Absolute Address | gem0: 0xE000B134 gem1: 0xE000C134 |
| Width | 32 bits |
| Access Type | ro |
| Reset Value | 0x00000000 |
| Description | Transmit under runs |

Register XEMACPS_TXURUNCNT_OFFSET Details

In statistics register block. Is reset to zero on a read and stick at all ones when it counts to its maximum value. It should be read frequently enough to prevent loss of data.

For test purposes, it may be written by setting bit 7 (Write Enable) in the network control register. Setting bit 6 (increment statistics) in the network control register causes all the statistics registers to increment by one, again for test purposes.

Once a statistics register has been read, it is automatically cleared.

| Field Name | Bits | Type | Reset Value | Description |
|---------------|-------|------|-------------|--|
| reserved | 31:10 | ro | 0x0 | Reserved, read as 0, ignored on write. |
| tx_under_runs | 9:0 | ro | 0x0 | Transmit under runs - a 10 bit register counting the number of frames not transmitted due to a transmit under run. If this register is incremented then no other statistics register is incremented. |

Register ([GEM](#)) XEMACPS_SNGLCOLLCNT_OFFSET

| | |
|------------------|--------------------------------------|
| Name | XEMACPS_SNGLCOLLCNT_OFFSET |
| Software Name | XEMACPS_SNGLCOLLCNT |
| Relative Address | 0x00000138 |
| Absolute Address | gem0: 0xE000B138 gem1: 0xE000C138 |
| Width | 32 bits |
| Access Type | ro |
| Reset Value | 0x00000000 |
| Description | Single Collision Frames |

Register XEMACPS_SNGLCOLLCNT_OFFSET Details

In statistics register block. Is reset to zero on a read and sticks at all ones when it counts to its maximum value. It should be read frequently enough to prevent loss of data.

For test purposes, it may be written by setting bit 7 (Write Enable) in the network control register. Setting bit 6 (increment statistics) in the network control register causes all the statistics registers to increment by one, again for test purposes.

Once a statistics register has been read, it is automatically cleared.

| Field Name | Bits | Type | Reset Value | Description |
|----------------|-------|------|-------------|--|
| reserved | 31:18 | ro | 0x0 | Reserved, read as 0, ignored on write. |
| single_collisn | 17:0 | ro | 0x0 | Single collision frames - an 18 bit register counting the number of frames experiencing a single collision before being successfully transmitted, i.e. no under run. |

Register ([GEM](#)) XEMACPS_MULTICOLLCNT_OFFSET

| | |
|------------------|--------------------------------------|
| Name | XEMACPS_MULTICOLLCNT_OFFSET |
| Software Name | XEMACPS_MULTICOLLCNT |
| Relative Address | 0x0000013C |
| Absolute Address | gem0: 0xE000B13C gem1: 0xE000C13C |
| Width | 32 bits |
| Access Type | ro |
| Reset Value | 0x00000000 |
| Description | Multiple Collision Frames |

Register XEMACPS_MULTICOLLCNT_OFFSET Details

In statistics register block. Is reset to zero on a read and sticks at all ones when it counts to its maximum value. It should be read frequently enough to prevent loss of data.

For test purposes, it may be written by setting bit 7 (Write Enable) in the network control register. Setting bit 6 (increment statistics) in the network control register causes all the statistics registers to increment by one, again for test purposes.

Once a statistics register has been read, it is automatically cleared.

| Field Name | Bits | Type | Reset Value | Description |
|---------------|-------|------|-------------|--|
| reserved | 31:18 | ro | 0x0 | Reserved, read as 0, ignored on write. |
| multi_collisn | 17:0 | ro | 0x0 | Multiple collision frames - an 18 bit register counting the number of frames experiencing between two and fifteen collisions prior to being successfully transmitted, i.e., no under run and not too many retries. |

Register ([GEM](#)) XEMACPS_EXCESSCOLLCNT_OFFSET

| | |
|------------------|--------------------------------------|
| Name | XEMACPS_EXCESSCOLLCNT_OFFSET |
| Software Name | XEMACPS_EXCESSCOLLCNT |
| Relative Address | 0x00000140 |
| Absolute Address | gem0: 0xE000B140 gem1: 0xE000C140 |
| Width | 32 bits |
| Access Type | ro |
| Reset Value | 0x00000000 |
| Description | Excessive Collisions |

Register XEMACPS_EXCESSCOLLCNT_OFFSET Details

In statistics register block. Is reset to zero on a read and sticks at all ones when it counts to its maximum value. It should be read frequently enough to prevent loss of data.

For test purposes, it may be written by setting bit 7 (Write Enable) in the network control register. Setting bit 6 (increment statistics) in the network control register causes all the statistics registers to increment by one, again for test purposes.

Once a statistics register has been read, it is automatically cleared.

| Field Name | Bits | Type | Reset Value | Description |
|--------------------|-------|------|-------------|--|
| reserved | 31:10 | ro | 0x0 | Reserved, read as 0, ignored on write. |
| excessive_collisns | 9:0 | ro | 0x0 | Excessive collisions - a 10 bit register counting the number of frames that failed to be transmitted because they experienced 16 collisions. |

Register ([GEM](#)) XEMACPS_LATECOLLCNT_OFFSET

| | |
|------------------|--------------------------------------|
| Name | XEMACPS_LATECOLLCNT_OFFSET |
| Software Name | XEMACPS_LATECOLLCNT |
| Relative Address | 0x00000144 |
| Absolute Address | gem0: 0xE000B144 gem1: 0xE000C144 |
| Width | 32 bits |
| Access Type | ro |
| Reset Value | 0x00000000 |
| Description | Late Collisions |

Register XEMACPS_LATECOLLCNT_OFFSET Details

In statistics register block. Is reset to zero on a read and sticks at all ones when it counts to its maximum value. It should be read frequently enough to prevent loss of data.

For test purposes, it may be written by setting bit 7 (Write Enable) in the network control register. Setting bit 6 (increment statistics) in the network control register causes all the statistics registers to increment by one, again for test purposes.

Once a statistics register has been read, it is automatically cleared.

| Field Name | Bits | Type | Reset Value | Description |
|---------------|-------|------|-------------|---|
| reserved | 31:10 | ro | 0x0 | Reserved, read as 0, ignored on write. |
| late_collisns | 9:0 | ro | 0x0 | Late collisions - a 10 bit register counting the number of late collision occurring after the slot time (512 bits) has expired. In 10/100 mode, late collisions are counted twice i.e., both as a collision and a late collision. In gigabit mode, a late collision causes the transmission to be aborted, thus the single and multi collision registers are not updated. |

Register ([GEM](#)) XEMACPS_TXDEFERCNT_OFFSET

| | |
|------------------|--------------------------------------|
| Name | XEMACPS_TXDEFERCNT_OFFSET |
| Software Name | XEMACPS_TXDEFERCNT |
| Relative Address | 0x00000148 |
| Absolute Address | gem0: 0xE000B148 gem1: 0xE000C148 |
| Width | 32 bits |
| Access Type | ro |
| Reset Value | 0x00000000 |
| Description | Deferred Transmission Frames |

Register XEMACPS_TXDEFERCNT_OFFSET Details

In statistics register block. Is reset to zero on a read and stick at all ones when it counts to its maximum value. It should be read frequently enough to prevent loss of data.

For test purposes, it may be written by setting bit 7 (Write Enable) in the network control register. Setting bit 6 (increment statistics) in the network control register causes all the statistics registers to increment by one, again for test purposes.

Once a statistics register has been read, it is automatically cleared.

| Field Name | Bits | Type | Reset Value | Description |
|-------------|-------|------|-------------|--|
| reserved | 31:18 | ro | 0x0 | Reserved, read as 0, ignored on write. |
| deferred_tx | 17:0 | ro | 0x0 | Deferred transmission frames - an 18 bit register counting the number of frames experiencing deferral due to carrier sense being active on their first attempt at transmission. Frames involved in any collision are not counted nor are frames that experienced a transmit under run. |

Register ([GEM](#)) XEMACPS_TXCSENSECNT_OFFSET

| | |
|------------------|--------------------------------------|
| Name | XEMACPS_TXCSENSECNT_OFFSET |
| Software Name | XEMACPS_TXCSENSECNT |
| Relative Address | 0x0000014C |
| Absolute Address | gem0: 0xE000B14C gem1: 0xE000C14C |
| Width | 32 bits |
| Access Type | ro |
| Reset Value | 0x00000000 |
| Description | Carrier Sense Errors. |

Register XEMACPS_TXCSENSECNT_OFFSET Details

In statistics register block. Is reset to zero on a read and sticks at all ones when it counts to its maximum value. It should be read frequently enough to prevent loss of data.

For test purposes, it may be written by setting bit 7 (Write Enable) in the network control register. Setting bit 6 (increment statistics) in the network control register causes all the statistics registers to increment by one, again for test purposes.

Once a statistics register has been read, it is automatically cleared.

| Field Name | Bits | Type | Reset Value | Description |
|--------------------|-------|------|-------------|--|
| reserved | 31:10 | ro | 0x0 | Reserved, read as 0, ignored on write. |
| carrier_sense_errs | 9:0 | ro | 0x0 | Carrier sense errors - a 10 bit register counting the number of frames transmitted where carrier sense was not seen during transmission or where carrier sense was deasserted after being asserted in a transmit frame without collision (no under run). Only incremented in half duplex mode. The only effect of a carrier sense error is to increment this register. The behavior of the other statistics registers is unaffected by the detection of a carrier sense error. |

Register ([GEM](#)) XEMACPS_OCTRXL_OFFSET

| | |
|------------------|--------------------------------------|
| Name | XEMACPS_OCTRXL_OFFSET |
| Software Name | XEMACPS_OCTRXL |
| Relative Address | 0x00000150 |
| Absolute Address | gem0: 0xE000B150 gem1: 0xE000C150 |
| Width | 32 bits |
| Access Type | ro |

Reset Value 0x00000000
 Description Octets Received [31:0]

Register XEMACPS_OCTRXL_OFFSET Details

Bits 31:0 should be read prior to bits 47:32 to ensure reliable operation. In statistics register block. Is reset to zero on a read and sticks at all ones when it counts to its maximum value. It should be read frequently enough to prevent loss of data.

For test purposes, it may be written by setting bit 7 (Write Enable) in the network control register. Setting bit 6 (increment statistics) in the network control register causes all the statistics registers to increment by one, again for test purposes.

Once a statistics register has been read, it is automatically cleared.

| Field Name | Bits | Type | Reset Value | Description |
|---------------|------|------|-------------|---|
| octets_rx_bot | 31:0 | ro | 0x0 | Received octets in frame without errors [31:0]. The number of octets received in valid frames of any type. This counter is 48-bits and is read through two registers. This count does not include octets from pause frames, and is only incremented if the frame is successfully filtered and copied to memory. |

Register ([GEM](#)) XEMACPS_OCTRXH_OFFSET

Name XEMACPS_OCTRXH_OFFSET
 Software Name XEMACPS_OCTRXH
 Relative Address 0x00000154
 Absolute Address gem0: 0xE000B154
 gem1: 0xE000C154
 Width 32 bits
 Access Type ro
 Reset Value 0x00000000
 Description Octets Received [47:32]

Register XEMACPS_OCTRXH_OFFSET Details

Bits 31:0 should be read prior to bits 47:32 to ensure reliable operation. In statistics register block. Is reset to zero on a read and sticks at all ones when it counts to its maximum value. It should be read frequently enough to prevent loss of data.

For test purposes, it may be written by setting bit 7 (Write Enable) in the network control register. Setting bit 6 (increment statistics) in the network control register causes all the statistics registers to increment by one, again for test purposes.

Once a statistics register has been read, it is automatically cleared.

| Field Name | Bits | Type | Reset Value | Description |
|---------------|-------|------|-------------|--|
| reserved | 31:16 | ro | 0x0 | Reserved, read as 0, ignored on write. |
| octets_rx_top | 15:0 | ro | 0x0 | Received octets in frame without errors [47:32]. The number of octets received in valid frames of any type. This counter is 48-bits and is read through two registers. This count does not include octets from pause frames, and is only incremented if the frame is successfully filtered and copied to memory. |

Register ([GEM](#)) XEMACPS_RXCNT_OFFSET

| | |
|------------------|--------------------------------------|
| Name | XEMACPS_RXCNT_OFFSET |
| Software Name | XEMACPS_RXCNT |
| Relative Address | 0x00000158 |
| Absolute Address | gem0: 0xE000B158 gem1: 0xE000C158 |
| Width | 32 bits |
| Access Type | ro |
| Reset Value | 0x00000000 |
| Description | Frames Received |

Register XEMACPS_RXCNT_OFFSET Details

Statistical counter for Frames received without an error and exclude pause frames.

NOTES for ALL Statistical registers for Frames Transferred:

The a statistical counter is read by software, it is cleared to zero by the hardware. When a counter reaches its maximum value, it stops counting and is read with all 1s. The statistical counters must be read frequently enough if data loss is to be prevented.

For test purposes, all of the statistical counters may be written to (not just read) by setting bit 7 (wren_stat_regs) in the network control register. Also for test purposes, all of the statistical counters can be incremented (by one) by writing a 1 to bit 6 (incr_stat_regs) of the network control register.

| Field Name | Bits | Type | Reset Value | Description |
|------------|------|------|-------------|--|
| | 31:0 | ro | 0x0 | Frames received without error. A 32 bit register counting the number of frames successfully received. Excludes pause frames, and is only incremented if the frame is successfully filtered and copied to memory. |

Register ([GEM](#)) XEMACPS_RXBROADCNT_OFFSET

| | |
|------------------|--------------------------------------|
| Name | XEMACPS_RXBROADCNT_OFFSET |
| Software Name | XEMACPS_RXBROADCNT |
| Relative Address | 0x0000015C |
| Absolute Address | gem0: 0xE000B15C gem1: 0xE000C15C |
| Width | 32 bits |
| Access Type | ro |
| Reset Value | 0x00000000 |
| Description | Broadcast Frames Rx |

Register XEMACPS_RXBROADCNT_OFFSET Details

Statistical counter for Broadcast Frames received without an error and exclude pause frames. Refer to the FRAMES_RX register for additional information.

| Field Name | Bits | Type | Reset Value | Description |
|------------|------|------|-------------|--|
| | 31:0 | ro | 0x0 | Broadcast frames received without error. A 32 bit register counting the number of broadcast frames successfully received without error. Excludes pause frames, and is only incremented if the frame is successfully filtered and copied to memory. |

Register ([GEM](#)) XEMACPS_RXMULTICNT_OFFSET

| | |
|------------------|--------------------------------------|
| Name | XEMACPS_RXMULTICNT_OFFSET |
| Software Name | XEMACPS_RXMULTICNT |
| Relative Address | 0x00000160 |
| Absolute Address | gem0: 0xE000B160 gem1: 0xE000C160 |
| Width | 32 bits |
| Access Type | ro |
| Reset Value | 0x00000000 |
| Description | Multicast Frames Rx |

Register XEMACPS_RXMULTICNT_OFFSET Details

Statistical counter for Multicast Frames received without an error and exclude pause frames. Refer to the FRAMES_RX register for additional information.

| Field Name | Bits | Type | Reset Value | Description |
|------------|------|------|-------------|--|
| | 31:0 | ro | 0x0 | Multicast frames received without error. A 32 bit register counting the number of multicast frames successfully received without error. Excludes pause frames, and is only incremented if the frame is successfully filtered and copied to memory. |

Register (GEM) XEMACPS_RXPAUSECNT_OFFSET

| | |
|------------------|--------------------------------------|
| Name | XEMACPS_RXPAUSECNT_OFFSET |
| Software Name | XEMACPS_RXPAUSECNT |
| Relative Address | 0x00000164 |
| Absolute Address | gem0: 0xE000B164 gem1: 0xE000C164 |
| Width | 32 bits |
| Access Type | ro |
| Reset Value | 0x00000000 |
| Description | Pause Frames Rx |

Register XEMACPS_RXPAUSECNT_OFFSET Details

Statistical counter for Pause Frames received without an error. Refer to the FRAMES_RX register for additional information.

| Field Name | Bits | Type | Reset Value | Description |
|------------|-------|------|-------------|---|
| reserved | 31:16 | ro | 0x0 | Reserved, read as 0, ignored on write. |
| pause_rx | 15:0 | ro | 0x0 | Received pause frames - a 16 bit register counting the number of pause frames received without error. |

Register (GEM) XEMACPS_RX64CNT_OFFSET

| | |
|------------------|--------------------------------------|
| Name | XEMACPS_RX64CNT_OFFSET |
| Software Name | XEMACPS_RX64CNT |
| Relative Address | 0x00000168 |
| Absolute Address | gem0: 0xE000B168 gem1: 0xE000C168 |
| Width | 32 bits |
| Access Type | ro |
| Reset Value | 0x00000000 |
| Description | Frames Rx, 64-byte length |

Register XEMACPS_RX64CNT_OFFSET Details

Statistical counter for frames of 64 bytes in length that are received without an error and exclude pause frames. Refer to the FRAMES_RX register for additional information.

| Field Name | Bits | Type | Reset Value | Description |
|------------|------|------|-------------|--|
| | 31:0 | ro | 0x0 | 64 byte frames received without error. A 32 bit register counting the number of 64 byte frames successfully received without error. Excludes pause frames, and is only incremented if the frame is successfully filtered and copied to memory. |

Register ([GEM](#)) XEMACPS_RX65CNT_OFFSET

| | |
|------------------|--------------------------------------|
| Name | XEMACPS_RX65CNT_OFFSET |
| Software Name | XEMACPS_RX65CNT |
| Relative Address | 0x0000016C |
| Absolute Address | gem0: 0xE000B16C gem1: 0xE000C16C |
| Width | 32 bits |
| Access Type | ro |
| Reset Value | 0x00000000 |
| Description | Frames Rx, 65 to 127-byte length |

Register XEMACPS_RX65CNT_OFFSET Details

Statistical counter for frames of 65 to 127 bytes in length that are received without an error and exclude pause frames. Refer to the FRAMES_RX register for additional information.

| Field Name | Bits | Type | Reset Value | Description |
|------------|------|------|-------------|--|
| | 31:0 | ro | 0x0 | 65 to 127 byte frames received without error. A 32 bit register counting the number of 65 to 127 byte frames successfully received without error. Excludes pause frames, and is only incremented if the frame is successfully filtered and copied to memory. |

Register ([GEM](#)) XEMACPS_RX128CNT_OFFSET

| | |
|------------------|-------------------------|
| Name | XEMACPS_RX128CNT_OFFSET |
| Software Name | XEMACPS_RX128CNT |
| Relative Address | 0x00000170 |

| | |
|------------------|--------------------------------------|
| Absolute Address | gem0: 0xE000B170 gem1: 0xE000C170 |
| Width | 32 bits |
| Access Type | ro |
| Reset Value | 0x00000000 |
| Description | Frames Rx, 128 to 255-byte length |

Register XEMACPS_RX128CNT_OFFSET Details

Statistical counter for frames of 128 to 255 bytes in length that are received without an error and exclude pause frames. Refer to the FRAMES_RX register for additional information.

| Field Name | Bits | Type | Reset Value | Description |
|------------|------|------|-------------|--|
| | 31:0 | ro | 0x0 | 128 to 255 byte frames received without error. A 32 bit register counting the number of 128 to 255 byte frames successfully received without error. Excludes pause frames, and is only incremented if the frame is successfully filtered and copied to memory. |

Register ([GEM](#)) XEMACPS_RX256CNT_OFFSET

| | |
|------------------|--------------------------------------|
| Name | XEMACPS_RX256CNT_OFFSET |
| Software Name | XEMACPS_RX256CNT |
| Relative Address | 0x00000174 |
| Absolute Address | gem0: 0xE000B174 gem1: 0xE000C174 |
| Width | 32 bits |
| Access Type | ro |
| Reset Value | 0x00000000 |
| Description | Frames Rx, 256 to 511-byte length |

Register XEMACPS_RX256CNT_OFFSET Details

Statistical counter for frames of 256 to 511 bytes in length that are received without an error and exclude pause frames. Refer to the FRAMES_RX register for additional information.

| Field Name | Bits | Type | Reset Value | Description |
|------------|------|------|-------------|---|
| | 31:0 | ro | 0x0 | 256 to 511 byte frames received without error. A 32 bit register counting the number of 256 to 511 byte frames successfully transmitted without error. Excludes pause frames, and is only incremented if the frame is successfully filtered and copied to memory. |

Register ([GEM](#)) XEMACPS_RX512CNT_OFFSET

| | |
|------------------|--------------------------------------|
| Name | XEMACPS_RX512CNT_OFFSET |
| Software Name | XEMACPS_RX512CNT |
| Relative Address | 0x00000178 |
| Absolute Address | gem0: 0xE000B178 gem1: 0xE000C178 |
| Width | 32 bits |
| Access Type | ro |
| Reset Value | 0x00000000 |
| Description | Frames Rx, 512 to 1023-byte length |

Register XEMACPS_RX512CNT_OFFSET Details

Statistical counter for frames of 512 to 1023 bytes in length that are received without an error and exclude pause frames. Refer to the FRAMES_RX register for additional information.

| Field Name | Bits | Type | Reset Value | Description |
|------------|------|------|-------------|--|
| | 31:0 | ro | 0x0 | 512 to 1023 byte frames received without error. A 32 bit register counting the number of 512 to 1023 byte frames successfully received without error. Excludes pause frames, and is only incremented if the frame is successfully filtered and copied to memory. |

Register ([GEM](#)) XEMACPS_RX1024CNT_OFFSET

| | |
|------------------|--------------------------------------|
| Name | XEMACPS_RX1024CNT_OFFSET |
| Software Name | XEMACPS_RX1024CNT |
| Relative Address | 0x0000017C |
| Absolute Address | gem0: 0xE000B17C gem1: 0xE000C17C |
| Width | 32 bits |
| Access Type | ro |
| Reset Value | 0x00000000 |
| Description | Frames Rx, 1024 to 1518-byte length |

Register XEMACPS_RX1024CNT_OFFSET Details

Statistical counter for frames of 1024 to 1518 bytes in length that are received without an error and exclude pause frames. Refer to the FRAMES_RX register for additional information.

| Field Name | Bits | Type | Reset Value | Description |
|------------|------|------|-------------|--|
| | 31:0 | ro | 0x0 | 1024 to 1518 byte frames received without error. A 32 bit register counting the number of 1024 to 1518 byte frames successfully received without error. Excludes pause frames, and is only incremented if the frame is successfully filtered and copied to memory. |

Register (GEM) XEMACPS_RXUNDRCNT_OFFSET

| | |
|------------------|--------------------------------------|
| Name | XEMACPS_RXUNDRCNT_OFFSET |
| Software Name | XEMACPS_RXUNDRCNT |
| Relative Address | 0x00000184 |
| Absolute Address | gem0: 0xE000B184 gem1: 0xE000C184 |
| Width | 32 bits |
| Access Type | ro |
| Reset Value | 0x00000000 |
| Description | Undersize frames received |

Register XEMACPS_RXUNDRCNT_OFFSET Details

| Field Name | Bits | Type | Reset Value | Description |
|------------|-------|------|-------------|---|
| reserved | 31:10 | ro | 0x0 | Reserved, read as 0, ignored on write. |
| undersz_rx | 9:0 | ro | 0x0 | Undersize frames received - a 10 bit register counting the number of frames received less than 64 bytes in length (10/100 mode or gigabit mode, full duplex) that do not have either a CRC error or an alignment error. |

Register (GEM) XEMACPS_RXOVRCNT_OFFSET

| | |
|------------------|--------------------------------------|
| Name | XEMACPS_RXOVRCNT_OFFSET |
| Software Name | XEMACPS_RXOVRCNT |
| Relative Address | 0x00000188 |
| Absolute Address | gem0: 0xE000B188 gem1: 0xE000C188 |
| Width | 32 bits |
| Access Type | ro |
| Reset Value | 0x00000000 |
| Description | Oversize frames received |

Register XEMACPS_RXOVRCNT_OFFSET Details

| Field Name | Bits | Type | Reset Value | Description |
|------------|-------|------|-------------|--|
| reserved | 31:10 | ro | 0x0 | Reserved, read as 0, ignored on write. |
| oversz_rx | 9:0 | ro | 0x0 | Oversize frames received - a 10 bit register counting the number of frames received exceeding 1518 bytes (1536 bytes if bit 8 is set in network configuration register) in length but do not have either a CRC error, an alignment error nor a receive symbol error. |

Register (GEM) XEMACPS_RXJABCNT_OFFSET

| | |
|------------------|--------------------------------------|
| Name | XEMACPS_RXJABCNT_OFFSET |
| Software Name | XEMACPS_RXJABCNT |
| Relative Address | 0x0000018C |
| Absolute Address | gem0: 0xE000B18C gem1: 0xE000C18C |
| Width | 32 bits |
| Access Type | ro |
| Reset Value | 0x00000000 |
| Description | Jabbers received |

Register XEMACPS_RXJABCNT_OFFSET Details

| Field Name | Bits | Type | Reset Value | Description |
|------------|-------|------|-------------|---|
| reserved | 31:10 | ro | 0x0 | Reserved, read as 0, ignored on write. |
| jab_rx | 9:0 | ro | 0x0 | Jabbers received - a 10 bit register counting the number of frames received exceeding 1518 bytes (1536 if bit 8 set in network configuration register) in length and have either a CRC error, an alignment error or a receive symbol error. |

Register (GEM) XEMACPS_RXFCSCNT_OFFSET

| | |
|------------------|--------------------------------------|
| Name | XEMACPS_RXFCSCNT_OFFSET |
| Software Name | XEMACPS_RXFCSCNT |
| Relative Address | 0x00000190 |
| Absolute Address | gem0: 0xE000B190 gem1: 0xE000C190 |
| Width | 32 bits |
| Access Type | ro |

Reset Value 0x00000000
 Description Frame check sequence errors

Register XEMACPS_RXFCSCNT_OFFSET Details

| Field Name | Bits | Type | Reset Value | Description |
|------------|-------|------|-------------|---|
| reserved | 31:10 | ro | 0x0 | Reserved, read as 0, ignored on write. |
| fcs_errors | 9:0 | ro | 0x0 | Frame check sequence errors - a 10 bit register counting frames that are an integral number of bytes, have bad CRC and are between 64 and 1518 bytes in length. This register is also incremented if a symbol error is detected and the frame is of valid length and has an integral number of bytes. This register is incremented for a frame with bad FCS, regardless of whether it is copied to memory due to ignore FCS mode being enabled in bit 26 of the network configuration register.H524 |

Register ([GEM](#)) XEMACPS_RXLENGTHCNT_OFFSET

Name XEMACPS_RXLENGTHCNT_OFFSET
 Software Name XEMACPS_RXLENGTHCNT
 Relative Address 0x00000194
 Absolute Address gem0: 0xE000B194
 gem1: 0xE000C194
 Width 32 bits
 Access Type ro
 Reset Value 0x00000000
 Description Length field frame errors

Register XEMACPS_RXLENGTHCNT_OFFSET Details

| Field Name | Bits | Type | Reset Value | Description |
|---------------------|-------|------|-------------|--|
| reserved | 31:10 | ro | 0x0 | Reserved, read as 0, ignored on write. |
| length_field_errors | 9:0 | ro | 0x0 | Length field frame errors - this 10-bit register counts the number of frames received that have a measured length shorter than that extracted from the length field (bytes 13 and 14). This condition is only counted if the value of the length field is less than 0x0600, the frame is not of excessive length and checking is enabled through bit 16 of the network configuration register. |

Register ([GEM](#)) XEMACPS_RXSYMBCNT_OFFSET

| | |
|------------------|--------------------------------------|
| Name | XEMACPS_RXSYMBCNT_OFFSET |
| Software Name | XEMACPS_RXSYMBCNT |
| Relative Address | 0x00000198 |
| Absolute Address | gem0: 0xE000B198 gem1: 0xE000C198 |
| Width | 32 bits |
| Access Type | ro |
| Reset Value | 0x00000000 |
| Description | Receive symbol errors |

Register XEMACPS_RXSYMBCNT_OFFSET Details

| Field Name | Bits | Type | Reset Value | Description |
|------------------|-------|------|-------------|---|
| reserved | 31:10 | ro | 0x0 | Reserved, read as 0, ignored on write. |
| rx_symbol_errors | 9:0 | ro | 0x0 | Receive symbol errors - a 10-bit register counting the number of frames that had rx_er asserted during reception. For 10/100 mode symbol errors are counted regardless of frame length checks. For gigabit mode the frame must satisfy slot time requirements in order to count a symbol error. |

Register ([GEM](#)) XEMACPS_RXALIGNCNT_OFFSET

| | |
|------------------|--------------------------------------|
| Name | XEMACPS_RXALIGNCNT_OFFSET |
| Software Name | XEMACPS_RXALIGNCNT |
| Relative Address | 0x0000019C |
| Absolute Address | gem0: 0xE000B19C gem1: 0xE000C19C |
| Width | 32 bits |
| Access Type | ro |
| Reset Value | 0x00000000 |
| Description | Alignment errors |

Register XEMACPS_RXALIGNCNT_OFFSET Details

| Field Name | Bits | Type | Reset Value | Description |
|--------------|-------|------|-------------|--|
| reserved | 31:10 | ro | 0x0 | Reserved, read as 0, ignored on write. |
| align_errors | 9:0 | ro | 0x0 | Alignment errors - a 10 bit register counting frames that are not an integral number of bytes long and have bad CRC when their length is truncated to an integral number of bytes and are between 64 and 1518 bytes in length. This register is also incremented if a symbol error is detected and the frame is of valid length and does not have an integral number of bytes. |

Register ([GEM](#)) XEMACPS_RXRESERRCNT_OFFSET

| | |
|------------------|--------------------------------------|
| Name | XEMACPS_RXRESERRCNT_OFFSET |
| Software Name | XEMACPS_RXRESERRCNT |
| Relative Address | 0x000001A0 |
| Absolute Address | gem0: 0xE000B1A0 gem1: 0xE000C1A0 |
| Width | 32 bits |
| Access Type | ro |
| Reset Value | 0x00000000 |
| Description | Receive resource errors |

Register XEMACPS_RXRESERRCNT_OFFSET Details

| Field Name | Bits | Type | Reset Value | Description |
|--------------------|-------|------|-------------|---|
| reserved | 31:18 | ro | 0x0 | Reserved, read as 0, ignored on write. |
| rx_resource_errors | 17:0 | ro | 0x0 | Receive resource errors - an 18 bit register counting the number of frames that were successfully received by the MAC (correct address matched frame and adequate slot time) but could not be copied to memory because no receive buffer was available. This will be either because the AHB bus was not granted in time or because a hresp not OK was returned. |

Register ([GEM](#)) XEMACPS_RXORCNT_OFFSET

| | |
|------------------|------------------------|
| Name | XEMACPS_RXORCNT_OFFSET |
| Software Name | XEMACPS_RXORCNT |
| Relative Address | 0x000001A4 |

Absolute Address gem0: 0xE000B1A4
 gem1: 0xE000C1A4

Width 32 bits

Access Type ro

Reset Value 0x00000000

Description Receive overrun errors

Register XEMACPS_RXORCNT_OFFSET Details

| Field Name | Bits | Type | Reset Value | Description |
|-------------------|-------|------|-------------|--|
| reserved | 31:10 | ro | 0x0 | Reserved, read as 0, ignored on write. |
| rx_overrun_errors | 9:0 | ro | 0x0 | Receive overruns - a 10 bit register counting the number of frames that are address recognized but were not copied to memory due to a receive overrun. |

Register ([GEM](#)) XEMACPS_RXIPCCNT_OFFSET

Name XEMACPS_RXIPCCNT_OFFSET

Software Name XEMACPS_RXIPCCNT

Relative Address 0x000001A8

Absolute Address gem0: 0xE000B1A8
 gem1: 0xE000C1A8

Width 32 bits

Access Type ro

Reset Value 0x00000000

Description IP header checksum errors

Register XEMACPS_RXIPCCNT_OFFSET Details

| Field Name | Bits | Type | Reset Value | Description |
|--------------------|------|------|-------------|--|
| reserved | 31:8 | ro | 0x0 | Reserved, read as 0, ignored on write. |
| ip_hdr_csum_errors | 7:0 | ro | 0x0 | 0 IP header checksum errors - an 8-bit register counting the number of frames discarded due to an incorrect IP header checksum, but are between 64 and 1518 bytes and do not have a CRC error, an alignment error, nor a symbol error. |

Register ([GEM](#)) XEMACPS_RXTCCNT_OFFSET

Name XEMACPS_RXTCCNT_OFFSET

Software Name XEMACPS_RXTCCNT

Relative Address 0x000001AC
 Absolute Address gem0: 0xE000B1AC
 gem1: 0xE000C1AC
 Width 32 bits
 Access Type ro
 Reset Value 0x00000000
 Description TCP checksum errors

Register XEMACPS_RXTCCNT_OFFSET Details

| Field Name | Bits | Type | Reset Value | Description |
|-----------------|------|------|-------------|--|
| reserved | 31:8 | ro | 0x0 | Reserved, read as 0, ignored on write. |
| tcp_csum_errors | 7:0 | ro | 0x0 | TCP checksum errors - an 8-bit register counting the number of frames discarded due to an incorrect TCP checksum, but are between 64 and 1518 bytes and do not have a CRC error, an alignment error, nor a symbol error. |

Register ([GEM](#)) XEMACPS_RXUDPCNT_OFFSET

Name XEMACPS_RXUDPCNT_OFFSET
 Software Name XEMACPS_RXUDPCNT
 Relative Address 0x000001B0
 Absolute Address gem0: 0xE000B1B0
 gem1: 0xE000C1B0
 Width 32 bits
 Access Type ro
 Reset Value 0x00000000
 Description UDP checksum error

Register XEMACPS_RXUDPCNT_OFFSET Details

| Field Name | Bits | Type | Reset Value | Description |
|-----------------|------|------|-------------|--|
| reserved | 31:8 | ro | 0x0 | Reserved, read as 0, ignored on write. |
| udp_csum_errors | 7:0 | ro | 0x0 | UDP checksum errors - an 8-bit register counting the number of frames discarded due to an incorrect UDP checksum, but are between 64 and 1518 bytes and do not have a CRC error, an alignment error, nor a symbol error. |

Register ([GEM](#)) XEMACPS_PTPP_RXNANOSEC_OFFSET

| | |
|------------------|--|
| Name | XEMACPS_PTPP_RXNANOSEC_OFFSET |
| Software Name | XEMACPS_PTPP_RXNANOSEC |
| Relative Address | 0x000001FC |
| Absolute Address | gem0: 0xE000B1FC gem1: 0xE000C1FC |
| Width | 32 bits |
| Access Type | ro |
| Reset Value | 0x00000000 |
| Description | PTP peer event frame received nanoseconds. |

Register ([GEM](#)) design_cfg2

| | |
|------------------|--------------------------------------|
| Name | design_cfg2 |
| Relative Address | 0x00000284 |
| Absolute Address | gem0: 0xE000B284 gem1: 0xE000C284 |
| Width | 32 bits |
| Access Type | ro |
| Reset Value | x |
| Description | Design Configuration 2 |

Register design_cfg2 Details

| Field Name | Bits | Type | Reset Value | Description |
|-------------------|-------|------|-------------|--|
| reserved | 31:30 | ro | x | Reserved. Set to zero. |
| gem_tx_pbuf_addr | 29:26 | ro | 0xA | Takes the value of the `gem_tx_pbuf_addr` DEFINE. Max address bits for Tx packet buffer (10-bits for maximum 4 kB buffer). Buffer size for Tx packet buffer mode will be 4kB. This will allow one standard packet to be received while another is transferred to system memory by the DMA interface. |
| gem_rx_pbuf_addr | 25:22 | ro | 0xA | Takes the value of the `gem_rx_pbuf_addr` DEFINE. Max address bits for Rx packet buffer (10-bits for maximum 4 kB buffer). Buffer size for Rx packet buffer mode will be 4kB. This will allow one standard packet to be received while another is transferred to system memory by the DMA interface. |
| gem_tx_pkt_buffer | 21 | ro | x | Takes the value of the `gem_tx_pkt_buffer` DEFINE. Defined for Zynq. Includes the transmitter packet buffer |

| Field Name | Bits | Type | Reset Value | Description |
|----------------------|-------|------|-------------|---|
| gem_rx_pkt_buffer | 20 | ro | x | Takes the value of the `gem_rx_pkt_buffer` DEFINE. Defined for Zynq. Includes the receiver packet buffer. |
| gem_hprot_value | 19:16 | ro | 0x1 | Takes the value of the `gem_hprot_value` DEFINE. For Zynq, set the fixed AHB HPROT value used during transfers. |
| gem_jumbo_max_length | 15:0 | ro | 0x3FFF | Takes the value of the `gem_jumbo_max_length` DEFINE. Maximum length of jumbo frames accepted by receiver. This is set to the size of the smallest of the two packet buffer, minus a margin for packet headers. However, Zynq will not support jumbo frames. |

Register ([GEM](#)) design_cfg3

| | |
|------------------|--------------------------------------|
| Name | design_cfg3 |
| Relative Address | 0x00000288 |
| Absolute Address | gem0: 0xE000B288 gem1: 0xE000C288 |
| Width | 32 bits |
| Access Type | ro |
| Reset Value | 0x00000000 |
| Description | Design Configuration 3 |

Register design_cfg3 Details

| Field Name | Bits | Type | Reset Value | Description |
|------------------------|-------|------|-------------|--|
| gem_rx_base2_fifo_size | 31:16 | ro | 0x0 | Takes the value of the `gem_rx_base2_fifo_size` DEFINE. Base-2 equivalent of `gem_rx_fifo_size` |
| gem_rx_fifo_size | 15:0 | ro | 0x0 | Takes the value of the `gem_rx_fifo_size` DEFINE. Set the size of the small Rx FIFO for grant latency. Extended to 16 deep to allow buffering of 64 byte maximum AHB burst size in Zynq. |

Register ([GEM](#)) design_cfg4

| | |
|------------------|--------------------------------------|
| Name | design_cfg4 |
| Relative Address | 0x0000028C |
| Absolute Address | gem0: 0xE000B28C gem1: 0xE000C28C |
| Width | 32 bits |
| Access Type | ro |

Reset Value 0x00000000
 Description Design Configuration 4

Register design_cfg4 Details

| Field Name | Bits | Type | Reset Value | Description |
|------------------------|-------|------|-------------|---|
| gem_tx_base2_fifo_size | 31:16 | ro | 0x0 | Takes the value of the `gem_tx_base2_fifo_size` DEFINE. Base-2 equivalent of `gem_tx_fifo_size`. |
| gem_tx_fifo_size | 15:0 | ro | 0x0 | Takes the value of the `gem_tx_fifo_size` DEFINE. Set the size of the small TX FIFO for grant latency |

Register ([GEM](#)) design_cfg5

Name design_cfg5
 Relative Address 0x00000290
 Absolute Address gem0: 0xE000B290
 gem1: 0xE000C290
 Width 32 bits
 Access Type ro
 Reset Value x
 Description Design Configuration 5

Register design_cfg5 Details

| Field Name | Bits | Type | Reset Value | Description |
|--------------------------|-------|------|-------------|---|
| reserved | 31:29 | ro | x | Reserved. Set to zero. |
| gem_tsu_clk | 28 | ro | x | Takes the value of the `gem_tsu_clk` DEFINE. Undefined in Zynq. 1588 Time Stamp Unit clock sourced from pclk rather than independent tsu_clk. |
| gem_rx_buffer_length_def | 27:20 | ro | 0x2 | Takes the value of the `gem_rx_buffer_length_def` DEFINE. Set the default buffer length used by Rx DMA to 128 bytes. |
| gem_tx_pbuf_size_def | 19 | ro | 0x1 | Takes the value of the `gem_tx_pbuf_size_def` DEFINE. Full 4 kB Tx packet buffer size - dedicated memory resource in Zynq. |
| gem_rx_pbuf_size_def | 18:17 | ro | 0x3 | Takes the value of the `gem_rx_pbuf_size_def` DEFINE. Full 4 kB Rx packet buffer size - dedicated memory resource in Zynq. |
| gem_endian_swap_def | 16:15 | ro | 0x2 | Takes the value of the `gem_endian_swap_def` DEFINE. Set to big endian data, little endian management descriptors in Zynq. |

| Field Name | Bits | Type | Reset Value | Description |
|-----------------------|-------|------|-------------|--|
| gem_mdc_clock_div | 14:12 | ro | 0x2 | Takes the value of the `gem_mdc_clock_div DEFINE. Set default MDC clock divisor (can still be programmed) in Zynq. |
| gem_dma_bus_width | 11:10 | ro | 0x0 | Takes the value of the `gem_dma_bus_width_def DEFINE. Limit to 32-bit AHB bus in Zynq. |
| gem_phy_ident | 9 | ro | x | Takes the value of the `gem_phy_ident DEFINE. Undefined in Zynq. Only used in PCS. |
| gem_tsu | 8 | ro | x | Takes the value of the `gem_tsu DEFINE. Defined in Zynq. Include support for 1588 Time Stamp Unit. |
| gem_tx_fifo_cnt_width | 7:4 | ro | 0x4 | Takes the value of the `gem_tx_fifo_cnt_width DEFINE. Width for `gem_tx_fifo_size |
| gem_rx_fifo_cnt_width | 3:0 | ro | 0x5 | Takes the value of the `gem_rx_fifo_cnt_width DEFINE. Width for `gem_rx_fifo_size. |

B.19 General Purpose I/O (gpio)

| | |
|---------------|--------------------------------|
| Module Name | General Purpose I/O (gpio) |
| Software Name | XGPIOPS |
| Base Address | 0xE000A000 gpio |
| Description | General Purpose Input / Output |
| Vendor Info | |

Register Summary

| Register Name | Address | Width | Type | Reset Value | Description |
|---|------------|-------|-------|-------------|---|
| XGPIOPS_DATA_LSW_OFFSET | 0x00000000 | 32 | mixed | x | Maskable Output Data (GPIO Bank0, MIO, Lower 16bits) |
| XGPIOPS_DATA_MSW_OFFSET | 0x00000004 | 32 | mixed | x | Maskable Output Data (GPIO Bank0, MIO, Upper 16bits) |
| MASK_DATA_1_LSW | 0x00000008 | 32 | mixed | x | Maskable Output Data (GPIO Bank1, MIO, Lower 16bits) |
| MASK_DATA_1_MSW | 0x0000000C | 22 | mixed | x | Maskable Output Data (GPIO Bank1, MIO, Upper 6bits) |
| MASK_DATA_2_LSW | 0x00000010 | 32 | mixed | 0x00000000 | Maskable Output Data (GPIO Bank2, EMIO, Lower 16bits) |
| MASK_DATA_2_MSW | 0x00000014 | 32 | mixed | 0x00000000 | Maskable Output Data (GPIO Bank2, EMIO, Upper 16bits) |
| MASK_DATA_3_LSW | 0x00000018 | 32 | mixed | 0x00000000 | Maskable Output Data (GPIO Bank3, EMIO, Lower 16bits) |
| MASK_DATA_3_MSW | 0x0000001C | 32 | mixed | 0x00000000 | Maskable Output Data (GPIO Bank3, EMIO, Upper 16bits) |
| XGPIOPS_DATA_OFFSET | 0x00000040 | 32 | rw | x | Output Data (GPIO Bank0, MIO) |
| DATA_1 | 0x00000044 | 22 | rw | x | Output Data (GPIO Bank1, MIO) |
| DATA_2 | 0x00000048 | 32 | rw | 0x00000000 | Output Data (GPIO Bank2, EMIO) |
| DATA_3 | 0x0000004C | 32 | rw | 0x00000000 | Output Data (GPIO Bank3, EMIO) |
| DATA_0_RO | 0x00000060 | 32 | ro | x | Input Data (GPIO Bank0, MIO) |
| DATA_1_RO | 0x00000064 | 22 | ro | x | Input Data (GPIO Bank1, MIO) |
| DATA_2_RO | 0x00000068 | 32 | ro | 0x00000000 | Input Data (GPIO Bank2, EMIO) |
| DATA_3_RO | 0x0000006C | 32 | ro | 0x00000000 | Input Data (GPIO Bank3, EMIO) |
| XGPIOPS_DIRM_OFFSET | 0x00000204 | 32 | rw | 0x00000000 | Direction mode (GPIO Bank0, MIO) |
| XGPIOPS_OUTEN_OFFSET | 0x00000208 | 32 | rw | 0x00000000 | Output enable (GPIO Bank0, MIO) |

| Register Name | Address | Width | Type | Reset Value | Description |
|--|------------|-------|------|--------------|--|
| XGPIOPS_INTMASK_OFFSET | 0x0000020C | 32 | ro | 0x00000000 | Interrupt Mask Status (GPIO Bank0, MIO) |
| XGPIOPS_INTEN_OFFSET | 0x00000210 | 32 | wo | 0x00000000 | Interrupt Enable/Unmask (GPIO Bank0, MIO) |
| XGPIOPS_INTDIS_OFFSET | 0x00000214 | 32 | wo | 0x00000000 | Interrupt Disable/Mask (GPIO Bank0, MIO) |
| XGPIOPS_INTSTS_OFFSET | 0x00000218 | 32 | wtc | 0x00000000 | Interrupt Status (GPIO Bank0, MIO) |
| XGPIOPS_INTTYPE_OFFSET | 0x0000021C | 32 | rw | 0xFFFFFFFF | Interrupt Type (GPIO Bank0, MIO) |
| XGPIOPS_INTPOL_OFFSET | 0x00000220 | 32 | rw | 0x00000000 | Interrupt Polarity (GPIO Bank0, MIO) |
| XGPIOPS_INTANY_OFFSET | 0x00000224 | 32 | rw | 0x00000000 | Interrupt Any Edge Sensitive (GPIO Bank0, MIO) |
| DIRM_1 | 0x00000244 | 22 | rw | 0x00000000 | Direction mode (GPIO Bank1, MIO) |
| OEN_1 | 0x00000248 | 22 | rw | 0x00000000 | Output enable (GPIO Bank1, MIO) |
| INT_MASK_1 | 0x0000024C | 22 | ro | 0x00000000 | Interrupt Mask Status (GPIO Bank1, MIO) |
| INT_EN_1 | 0x00000250 | 22 | wo | 0x00000000 | Interrupt Enable/Unmask (GPIO Bank1, MIO) |
| INT_DIS_1 | 0x00000254 | 22 | wo | 0x00000000 | Interrupt Disable/Mask (GPIO Bank1, MIO) |
| INT_STAT_1 | 0x00000258 | 22 | wtc | 0x00000000 | Interrupt Status (GPIO Bank1, MIO) |
| INT_TYPE_1 | 0x0000025C | 22 | rw | 0x003FFFFFFF | Interrupt Type (GPIO Bank1, MIO) |
| INT_POLARITY_1 | 0x00000260 | 22 | rw | 0x00000000 | Interrupt Polarity (GPIO Bank1, MIO) |
| INT_ANY_1 | 0x00000264 | 22 | rw | 0x00000000 | Interrupt Any Edge Sensitive (GPIO Bank1, MIO) |
| DIRM_2 | 0x00000284 | 32 | rw | 0x00000000 | Direction mode (GPIO Bank2, EMIO) |
| OEN_2 | 0x00000288 | 32 | rw | 0x00000000 | Output enable (GPIO Bank2, EMIO) |
| INT_MASK_2 | 0x0000028C | 32 | ro | 0x00000000 | Interrupt Mask Status (GPIO Bank2, EMIO) |
| INT_EN_2 | 0x00000290 | 32 | wo | 0x00000000 | Interrupt Enable/Unmask (GPIO Bank2, EMIO) |
| INT_DIS_2 | 0x00000294 | 32 | wo | 0x00000000 | Interrupt Disable/Mask (GPIO Bank2, EMIO) |
| INT_STAT_2 | 0x00000298 | 32 | wtc | 0x00000000 | Interrupt Status (GPIO Bank2, EMIO) |

| Register Name | Address | Width | Type | Reset Value | Description |
|--------------------------------|------------|-------|------|-------------|---|
| INT_TYPE_2 | 0x0000029C | 32 | rw | 0xFFFFFFFF | Interrupt Type (GPIO Bank2, EMIO) |
| INT_POLARITY_2 | 0x000002A0 | 32 | rw | 0x00000000 | Interrupt Polarity (GPIO Bank2, EMIO) |
| INT_ANY_2 | 0x000002A4 | 32 | rw | 0x00000000 | Interrupt Any Edge Sensitive (GPIO Bank2, EMIO) |
| DIRM_3 | 0x000002C4 | 32 | rw | 0x00000000 | Direction mode (GPIO Bank3, EMIO) |
| OEN_3 | 0x000002C8 | 32 | rw | 0x00000000 | Output enable (GPIO Bank3, EMIO) |
| INT_MASK_3 | 0x000002CC | 32 | ro | 0x00000000 | Interrupt Mask Status (GPIO Bank3, EMIO) |
| INT_EN_3 | 0x000002D0 | 32 | wo | 0x00000000 | Interrupt Enable/Unmask (GPIO Bank3, EMIO) |
| INT_DIS_3 | 0x000002D4 | 32 | wo | 0x00000000 | Interrupt Disable/Mask (GPIO Bank3, EMIO) |
| INT_STAT_3 | 0x000002D8 | 32 | wtc | 0x00000000 | Interrupt Status (GPIO Bank3, EMIO) |
| INT_TYPE_3 | 0x000002DC | 32 | rw | 0xFFFFFFFF | Interrupt Type (GPIO Bank3, EMIO) |
| INT_POLARITY_3 | 0x000002E0 | 32 | rw | 0x00000000 | Interrupt Polarity (GPIO Bank3, EMIO) |
| INT_ANY_3 | 0x000002E4 | 32 | rw | 0x00000000 | Interrupt Any Edge Sensitive (GPIO Bank3, EMIO) |

Register ([gpio](#)) XGPIOPS_DATA_LSW_OFFSET

| | |
|------------------|--|
| Name | XGPIOPS_DATA_LSW_OFFSET |
| Software Name | DATA_LSW |
| Relative Address | 0x00000000 |
| Absolute Address | 0xE000A000 |
| Width | 32 bits |
| Access Type | mixed |
| Reset Value | x |
| Description | Maskable Output Data (GPIO Bank0, MIO, Lower 16bits) |

Register XGPIOPS_DATA_LSW_OFFSET Details

This register enables software to change the value being output on up to 16bits at one time selectively. Only data values with a corresponding deasserted mask bit will be changed. Output data values are unchanged and hold their previous value for bits which are masked. This register avoids the need for a read-modify-write sequence for unchanged bits.

NOTE: This register does not affect the enabling of the output driver. See the DIRM_0 and OEN_0 registers.

This register controls the output values for the lower 16bits of bank0, which corresponds to MIO[15:0].

| Field Name | Bits | Type | Reset Value | Description |
|------------|-------|------|-------------|---|
| MASK_0_LSW | 31:16 | wo | 0x0 | On a write, only bits with a corresponding deasserted mask will change the output value. 0: pin value is updated 1: pin is masked Each bit controls the corresponding pin within the 16-bit half-bank. Reads return 0's. |
| DATA_0_LSW | 15:0 | rw | x | On a write, these are the data values for the corresponding GPIO output bits. Each bit controls the corresponding pin within the 16-bit half-bank. Reads return the previous value written to this register or DATA_0[15:0]. Reads do not return the value on the GPIO pin. |

Register ([gpio](#)) XGPIOPS_DATA_MSW_OFFSET

| | |
|------------------|--|
| Name | XGPIOPS_DATA_MSW_OFFSET |
| Software Name | DATA_MSW |
| Relative Address | 0x00000004 |
| Absolute Address | 0xE000A004 |
| Width | 32 bits |
| Access Type | mixed |
| Reset Value | x |
| Description | Maskable Output Data (GPIO Bank0, MIO, Upper 16bits) |

Register XGPIOPS_DATA_MSW_OFFSET Details

This register operates in exactly the same manner as MASK_DATA_0_LSW, except that it controls the upper 16bits of bank0, which corresponds to MIO[31:16].

| Field Name | Bits | Type | Reset Value | Description |
|------------|-------|------|-------------|--|
| MASK_0_MSW | 31:16 | wo | 0x0 | Operation is the same as MASK_DATA_0_LSW[MASK_0_LSW] |
| DATA_0_MSW | 15:0 | rw | x | Operation is the same as MASK_DATA_0_LSW[DATA_0_LSW] |

Register ([gpio](#)) MASK_DATA_1_LSW

| | |
|------------------|--|
| Name | MASK_DATA_1_LSW |
| Relative Address | 0x00000008 |
| Absolute Address | 0xE000A008 |
| Width | 32 bits |
| Access Type | mixed |
| Reset Value | x |
| Description | Maskable Output Data (GPIO Bank1, MIO, Lower 16bits) |

Register MASK_DATA_1_LSW Details

This register operates in exactly the same manner as MASK_DATA_0_LSW, except that it controls the lower 16bits of bank1, which corresponds to MIO[47:32].

| Field Name | Bits | Type | Reset Value | Description |
|------------|-------|------|-------------|--|
| MASK_1_LSW | 31:16 | wo | 0x0 | Operation is the same as MASK_DATA_0_LSW[MASK_0_LSW] |
| DATA_1_LSW | 15:0 | rw | x | Operation is the same as MASK_DATA_0_LSW[DATA_0_LSW] |

Register ([gpio](#)) MASK_DATA_1_MSW

| | |
|------------------|---|
| Name | MASK_DATA_1_MSW |
| Relative Address | 0x0000000C |
| Absolute Address | 0xE000A00C |
| Width | 22 bits |
| Access Type | mixed |
| Reset Value | x |
| Description | Maskable Output Data (GPIO Bank1, MIO, Upper 6bits) |

Register MASK_DATA_1_MSW Details

This register operates in exactly the same manner as MASK_DATA_0_LSW, except that it controls the upper 6bits of bank1, which corresponds to MIO[53:48].

NOTE: This register does not control a full 16bits because the MIO unit itself is limited to 54 pins.

| Field Name | Bits | Type | Reset Value | Description |
|------------|-------|------|-------------|--|
| MASK_1_MSW | 21:16 | wo | 0x0 | Operation is the same as MASK_DATA_0_LSW[MASK_0_LSW] |

| Field Name | Bits | Type | Reset Value | Description |
|------------|------|------|-------------|--|
| reserved | 15:6 | rw | 0x0 | Not used, read back as zero |
| DATA_1_MSW | 5:0 | rw | x | Operation is the same as MASK_DATA_0_LSW[DATA_0_LSW] |

Register ([gpio](#)) MASK_DATA_2_LSW

| | |
|------------------|---|
| Name | MASK_DATA_2_LSW |
| Relative Address | 0x00000010 |
| Absolute Address | 0xE000A010 |
| Width | 32 bits |
| Access Type | mixed |
| Reset Value | 0x00000000 |
| Description | Maskable Output Data (GPIO Bank2, EMIO, Lower 16bits) |

Register MASK_DATA_2_LSW Details

This register operates in exactly the same manner as MASK_DATA_0_LSW, except that it controls the lower 16bits of bank2, which corresponds to EMIO[15:0].

| Field Name | Bits | Type | Reset Value | Description |
|------------|-------|------|-------------|--|
| MASK_2_LSW | 31:16 | wo | 0x0 | Operation is the same as MASK_DATA_0_LSW[MASK_0_LSW] |
| DATA_2_LSW | 15:0 | rw | 0x0 | Operation is the same as MASK_DATA_0_LSW[DATA_0_LSW] |

Register ([gpio](#)) MASK_DATA_2_MSW

| | |
|------------------|---|
| Name | MASK_DATA_2_MSW |
| Relative Address | 0x00000014 |
| Absolute Address | 0xE000A014 |
| Width | 32 bits |
| Access Type | mixed |
| Reset Value | 0x00000000 |
| Description | Maskable Output Data (GPIO Bank2, EMIO, Upper 16bits) |

Register MASK_DATA_2_MSW Details

This register operates in exactly the same manner as MASK_DATA_0_LSW, except that it controls the upper 16bits of bank2, which corresponds to EMIO[31:16].

| Field Name | Bits | Type | Reset Value | Description |
|------------|-------|------|-------------|--|
| MASK_2_MSW | 31:16 | wo | 0x0 | Operation is the same as MASK_DATA_0_LSW[MASK_0_LSW] |
| DATA_2_MSW | 15:0 | rw | 0x0 | Operation is the same as MASK_DATA_0_LSW[DATA_0_LSW] |

Register ([gpio](#)) MASK_DATA_3_LSW

| | |
|------------------|---|
| Name | MASK_DATA_3_LSW |
| Relative Address | 0x00000018 |
| Absolute Address | 0xE000A018 |
| Width | 32 bits |
| Access Type | mixed |
| Reset Value | 0x00000000 |
| Description | Maskable Output Data (GPIO Bank3, EMIO, Lower 16bits) |

Register MASK_DATA_3_LSW Details

This register operates in exactly the same manner as MASK_DATA_0_LSW, except that it controls the lower 16bits of bank3, which corresponds to EMIO[47:32].

| Field Name | Bits | Type | Reset Value | Description |
|------------|-------|------|-------------|--|
| MASK_3_LSW | 31:16 | wo | 0x0 | Operation is the same as MASK_DATA_0_LSW[MASK_0_LSW] |
| DATA_3_LSW | 15:0 | rw | 0x0 | Operation is the same as MASK_DATA_0_LSW[DATA_0_LSW] |

Register ([gpio](#)) MASK_DATA_3_MSW

| | |
|------------------|---|
| Name | MASK_DATA_3_MSW |
| Relative Address | 0x0000001C |
| Absolute Address | 0xE000A01C |
| Width | 32 bits |
| Access Type | mixed |
| Reset Value | 0x00000000 |
| Description | Maskable Output Data (GPIO Bank3, EMIO, Upper 16bits) |

Register MASK_DATA_3_MSW Details

This register operates in exactly the same manner as MASK_DATA_0_LSW, except that it controls the upper 16bits of bank3, which corresponds to EMIO[63:48].

| Field Name | Bits | Type | Reset Value | Description |
|------------|-------|------|-------------|--|
| MASK_3_MSW | 31:16 | wo | 0x0 | Operation is the same as MASK_DATA_0_LSW[MASK_0_LSW] |
| DATA_3_MSW | 15:0 | rw | 0x0 | Operation is the same as MASK_DATA_0_LSW[DATA_0_LSW] |

Register ([gpio](#)) XGPIOPS_DATA_OFFSET

| | |
|------------------|-------------------------------|
| Name | XGPIOPS_DATA_OFFSET |
| Software Name | DATA |
| Relative Address | 0x00000040 |
| Absolute Address | 0xE000A040 |
| Width | 32 bits |
| Access Type | rw |
| Reset Value | x |
| Description | Output Data (GPIO Bank0, MIO) |

Register XGPIOPS_DATA_OFFSET Details

This register controls the value being output when the GPIO signal is configured as an output. All 32bits of this register are written at one time. Reading from this register returns the previous value written to either DATA or MASK_DATA_{LSW,MSW}; it does not return the value on the device pin.

NOTE: This register does not affect the enabling of the output driver. See the DIRM_0 and OEN_0 registers.

This register controls the output values for bank0, which corresponds to MIO[31:0].

| Field Name | Bits | Type | Reset Value | Description |
|------------|------|------|-------------|-------------|
| DATA_0 | 31:0 | rw | x | Output Data |

Register ([gpio](#)) DATA_1

| | |
|------------------|-------------------------------|
| Name | DATA_1 |
| Relative Address | 0x00000044 |
| Absolute Address | 0xE000A044 |
| Width | 22 bits |
| Access Type | rw |
| Reset Value | x |
| Description | Output Data (GPIO Bank1, MIO) |

Register DATA_1 Details

This register operates in exactly the same manner as DATA_0, except that it controls bank1, which corresponds to MIO[53:32].

| Field Name | Bits | Type | Reset Value | Description |
|------------|------|------|-------------|-------------|
| DATA_1 | 21:0 | rw | x | Output Data |

Register (gpio) DATA_2

| | |
|------------------|--------------------------------|
| Name | DATA_2 |
| Relative Address | 0x00000048 |
| Absolute Address | 0xE000A048 |
| Width | 32 bits |
| Access Type | rw |
| Reset Value | 0x00000000 |
| Description | Output Data (GPIO Bank2, EMIO) |

Register DATA_2 Details

This register operates in exactly the same manner as DATA_0, except that it controls bank2, which corresponds to EMIO[31:0].

| Field Name | Bits | Type | Reset Value | Description |
|------------|------|------|-------------|-------------|
| DATA_2 | 31:0 | rw | 0x0 | Output Data |

Register (gpio) DATA_3

| | |
|------------------|--------------------------------|
| Name | DATA_3 |
| Relative Address | 0x0000004C |
| Absolute Address | 0xE000A04C |
| Width | 32 bits |
| Access Type | rw |
| Reset Value | 0x00000000 |
| Description | Output Data (GPIO Bank3, EMIO) |

Register DATA_3 Details

This register operates in exactly the same manner as DATA_0, except that it controls bank3, which corresponds to EMIO[63:32].

| Field Name | Bits | Type | Reset Value | Description |
|------------|------|------|-------------|-------------|
| DATA_3 | 31:0 | rw | 0x0 | Output Data |

Register ([gpio](#)) DATA_0_RO

| | |
|------------------|------------------------------|
| Name | DATA_0_RO |
| Relative Address | 0x00000060 |
| Absolute Address | 0xE000A060 |
| Width | 32 bits |
| Access Type | ro |
| Reset Value | x |
| Description | Input Data (GPIO Bank0, MIO) |

Register DATA_0_RO Details

This register enables software to observe the value on the device pin. If the GPIO signal is configured as an output, then this would normally reflect the value being driven on the output. Writes to this register are ignored.

This register reflects the input values for bank0, which corresponds to MIO[31:0].

NOTE: If the MIO is not configured to enable this pin as a GPIO pin, then DATA_RO is unpredictable. In other words, software cannot observe values on non-GPIO pins through the GPIO registers.

| Field Name | Bits | Type | Reset Value | Description |
|------------|------|------|-------------|--|
| DATA_0_RO | 31:0 | ro | x | Input Data NOTE: bits[8:7] of bank0 cannot be used as inputs and will always return 0 when read. See the GPIO chapter for more information. |

Register ([gpio](#)) DATA_1_RO

| | |
|------------------|------------------------------|
| Name | DATA_1_RO |
| Relative Address | 0x00000064 |
| Absolute Address | 0xE000A064 |
| Width | 22 bits |
| Access Type | ro |
| Reset Value | x |
| Description | Input Data (GPIO Bank1, MIO) |

Register DATA_1_RO Details

This register operates in exactly the same manner as DATA_0_RO, except that it reflects bank1, which corresponds to MIO[53:32].

| Field Name | Bits | Type | Reset Value | Description |
|------------|------|------|-------------|-------------|
| DATA_1_RO | 21:0 | ro | x | Input Data |

Register ([gpio](#)) DATA_2_RO

| | |
|------------------|-------------------------------|
| Name | DATA_2_RO |
| Relative Address | 0x00000068 |
| Absolute Address | 0xE000A068 |
| Width | 32 bits |
| Access Type | ro |
| Reset Value | 0x00000000 |
| Description | Input Data (GPIO Bank2, EMIO) |

Register DATA_2_RO Details

This register operates in exactly the same manner as DATA_0_RO, except that it reflects bank2, which corresponds to EMIO[31:0].

| Field Name | Bits | Type | Reset Value | Description |
|------------|------|------|-------------|-------------|
| DATA_2_RO | 31:0 | ro | 0x0 | Input Data |

Register ([gpio](#)) DATA_3_RO

| | |
|------------------|-------------------------------|
| Name | DATA_3_RO |
| Relative Address | 0x0000006C |
| Absolute Address | 0xE000A06C |
| Width | 32 bits |
| Access Type | ro |
| Reset Value | 0x00000000 |
| Description | Input Data (GPIO Bank3, EMIO) |

Register DATA_3_RO Details

This register operates in exactly the same manner as DATA_0_RO, except that it reflects bank3, which corresponds to EMIO[63:32].

| Field Name | Bits | Type | Reset Value | Description |
|------------|------|------|-------------|-------------|
| DATA_3_RO | 31:0 | ro | 0x0 | Input Data |

Register ([gpio](#)) XGPIOPS_DIRM_OFFSET

| | |
|------------------|----------------------------------|
| Name | XGPIOPS_DIRM_OFFSET |
| Software Name | DIRM |
| Relative Address | 0x00000204 |
| Absolute Address | 0xE000A204 |
| Width | 32 bits |
| Access Type | rw |
| Reset Value | 0x00000000 |
| Description | Direction mode (GPIO Bank0, MIO) |

Register XGPIOPS_DIRM_OFFSET Details

This register controls whether the IO pin is acting as an input or an output. Since the input logic is always enabled, this effectively enables/disables the output driver.

Each bit of the bank is independently controlled.

This register controls bank0, which corresponds to MIO[31:0].

| Field Name | Bits | Type | Reset Value | Description |
|-------------|------|------|-------------|---|
| DIRECTION_0 | 31:0 | rw | 0x0 | Direction mode 0: input 1: output Each bit configures the corresponding pin within the 32-bit bank NOTE: bits[8:7] of bank0 cannot be used as inputs. The DIRM bits can be set to 0, but reading DATA_RO does not reflect the input value. See the GPIO chapter for more information. |

Register ([gpio](#)) XGPIOPS_OUTEN_OFFSET

| | |
|------------------|----------------------|
| Name | XGPIOPS_OUTEN_OFFSET |
| Software Name | OUTEN |
| Relative Address | 0x00000208 |
| Absolute Address | 0xE000A208 |
| Width | 32 bits |
| Access Type | rw |
| Reset Value | 0x00000000 |

Description Output enable (GPIO Bank0, MIO)

Register XGPIOPS_OUTEN_OFFSET Details

When the IO is configured as an output, this controls whether the output is enabled or not. When the output is disabled, the pin is tri-stated.

NOTE: The MIO driver setting (slcr.MIO_PIN_xx.TRI_ENABLE field) must be disabled (i.e. set to 0) for this field to be operational. When the MIO tri-state is enabled, the driver is disabled regardless of this GPIO setting.

This register controls bank0, which corresponds to MIO[31:0].

| Field Name | Bits | Type | Reset Value | Description |
|-------------|------|------|-------------|---|
| OP_ENABLE_0 | 31:0 | rw | 0x0 | Output enables 0: disabled 1: enabled Each bit configures the corresponding pin within the 32-bit bank |

Register ([gpio](#)) XGPIOPS_INTMASK_OFFSET

Name XGPIOPS_INTMASK_OFFSET
 Software Name INTMASK
 Relative Address 0x0000020C
 Absolute Address 0xE000A20C
 Width 32 bits
 Access Type ro
 Reset Value 0x00000000
 Description Interrupt Mask Status (GPIO Bank0, MIO)

Register XGPIOPS_INTMASK_OFFSET Details

This register shows which bits are currently masked and which are un-masked/enabled. This register is read only, so masks cannot be changed here. Use INT_EN and INT_DIS to change the mask value.

This register controls bank0, which corresponds to MIO[31:0].

| Field Name | Bits | Type | Reset Value | Description |
|------------|------|------|-------------|---|
| INT_MASK_0 | 31:0 | ro | 0x0 | Interrupt mask 0: interrupt source enabled 1: interrupt source masked Each bit reports the status for the corresponding pin within the 32-bit bank |

Register ([gpio](#)) XGPIOPS_INTEN_OFFSET

| | |
|------------------|---|
| Name | XGPIOPS_INTEN_OFFSET |
| Software Name | INTEN |
| Relative Address | 0x00000210 |
| Absolute Address | 0xE000A210 |
| Width | 32 bits |
| Access Type | wo |
| Reset Value | 0x00000000 |
| Description | Interrupt Enable/Unmask (GPIO Bank0, MIO) |

Register XGPIOPS_INTEN_OFFSET Details

This register is used to enable or unmask a GPIO input for use as an interrupt source. Writing a 1 to any bit of this register enables/unmasks that signal for interrupts. Reading from this register returns an unpredictable value.

This register controls bank0, which corresponds to MIO[31:0].

| Field Name | Bits | Type | Reset Value | Description |
|--------------|------|------|-------------|---|
| INT_ENABLE_0 | 31:0 | wo | 0x0 | Interrupt enable 0: no change 1: clear interrupt mask Each bit configures the corresponding pin within the 32-bit bank |

Register ([gpio](#)) XGPIOPS_INTDIS_OFFSET

| | |
|------------------|--|
| Name | XGPIOPS_INTDIS_OFFSET |
| Software Name | INTDIS |
| Relative Address | 0x00000214 |
| Absolute Address | 0xE000A214 |
| Width | 32 bits |
| Access Type | wo |
| Reset Value | 0x00000000 |
| Description | Interrupt Disable/Mask (GPIO Bank0, MIO) |

Register XGPIOPS_INTDIS_OFFSET Details

This register is used to disable or mask a GPIO input for use as an interrupt source. Writing a 1 to any bit of this register disables/masks that signal for interrupts. Reading from this register returns an unpredictable value.

This register controls bank0, which corresponds to MIO[31:0].

| Field Name | Bits | Type | Reset Value | Description |
|---------------|------|------|-------------|--|
| INT_DISABLE_0 | 31:0 | wo | 0x0 | Interrupt disable 0: no change 1: set interrupt mask Each bit configures the corresponding pin within the 32-bit bank |

Register ([gpio](#)) XGPIOPS_INTSTS_OFFSET

| | |
|------------------|------------------------------------|
| Name | XGPIOPS_INTSTS_OFFSET |
| Software Name | INTSTS |
| Relative Address | 0x00000218 |
| Absolute Address | 0xE000A218 |
| Width | 32 bits |
| Access Type | wtc |
| Reset Value | 0x00000000 |
| Description | Interrupt Status (GPIO Bank0, MIO) |

Register XGPIOPS_INTSTS_OFFSET Details

This registers shows if an interrupt event has occurred or not. Writing a 1 to a bit in this register clears the interrupt status for that bit. Writing a 0 to a bit in this register is ignored.

This register controls bank0, which corresponds to MIO[31:0].

| Field Name | Bits | Type | Reset Value | Description |
|--------------|------|------|-------------|--|
| INT_STATUS_0 | 31:0 | wtc | 0x0 | Interrupt status Upon read: 0: no interrupt 1: interrupt event has occurred Upon write: 0: no action 1: clear interrupt status bit Each bit configures the corresponding pin within the 32-bit bank |

Register ([gpio](#)) XGPIOPS_INTTYPE_OFFSET

| | |
|------------------|------------------------|
| Name | XGPIOPS_INTTYPE_OFFSET |
| Software Name | INTTYPE |
| Relative Address | 0x0000021C |

| | |
|------------------|----------------------------------|
| Absolute Address | 0xE000A21C |
| Width | 32 bits |
| Access Type | rw |
| Reset Value | 0xFFFFFFFF |
| Description | Interrupt Type (GPIO Bank0, MIO) |

Register XGPIOPS_INTTYPE_OFFSET Details

This register controls whether the interrupt is edge sensitive or level sensitive.

This register controls bank0, which corresponds to MIO[31:0].

| Field Name | Bits | Type | Reset Value | Description |
|------------|------|------|-------------|---|
| INT_TYPE_0 | 31:0 | rw | 0xFFFFFFFF | Interrupt type 0: level-sensitive 1: edge-sensitive Each bit configures the corresponding pin within the 32-bit bank |

Register ([gpio](#)) XGPIOPS_INTPOL_OFFSET

| | |
|------------------|--------------------------------------|
| Name | XGPIOPS_INTPOL_OFFSET |
| Software Name | INTPOL |
| Relative Address | 0x00000220 |
| Absolute Address | 0xE000A220 |
| Width | 32 bits |
| Access Type | rw |
| Reset Value | 0x00000000 |
| Description | Interrupt Polarity (GPIO Bank0, MIO) |

Register XGPIOPS_INTPOL_OFFSET Details

This register controls whether the interrupt is active-low or active high (or falling-edge sensitive or rising-edge sensitive).

This register controls bank0, which corresponds to MIO[31:0].

| Field Name | Bits | Type | Reset Value | Description |
|------------|------|------|-------------|--|
| INT_POL_0 | 31:0 | rw | 0x0 | Interrupt polarity 0: active low or falling edge 1: active high or rising edge Each bit configures the corresponding pin within the 32-bit bank |

Register ([gpio](#)) XGPIOPS_INTANY_OFFSET

| | |
|------------------|--|
| Name | XGPIOPS_INTANY_OFFSET |
| Software Name | INTANY |
| Relative Address | 0x00000224 |
| Absolute Address | 0xE000A224 |
| Width | 32 bits |
| Access Type | rw |
| Reset Value | 0x00000000 |
| Description | Interrupt Any Edge Sensitive (GPIO Bank0, MIO) |

Register XGPIOPS_INTANY_OFFSET Details

If INT_TYPE is set to edge sensitive, then this register enables an interrupt event on both rising and falling edges. This register is ignored if INT_TYPE is set to level sensitive.

This register controls bank0, which corresponds to MIO[31:0].

| Field Name | Bits | Type | Reset Value | Description |
|--------------|------|------|-------------|--|
| INT_ON_ANY_0 | 31:0 | rw | 0x0 | Interrupt edge triggering mode 0: trigger on single edge, using configured interrupt polarity 1: trigger on both edges Each bit configures the corresponding pin within the 32-bit bank |

Register ([gpio](#)) DIRM_1

| | |
|------------------|----------------------------------|
| Name | DIRM_1 |
| Relative Address | 0x00000244 |
| Absolute Address | 0xE000A244 |
| Width | 22 bits |
| Access Type | rw |
| Reset Value | 0x00000000 |
| Description | Direction mode (GPIO Bank1, MIO) |

Register DIRM_1 Details

This register operates in exactly the same manner as DIRM_0, except that it reflects bank1, which corresponds to MIO[53:32].

| Field Name | Bits | Type | Reset Value | Description |
|-------------|------|------|-------------|--|
| DIRECTION_1 | 21:0 | rw | 0x0 | Operation is the same as DIRM_0[DIRECTION_0] |

Register ([gpio](#)) OEN_1

| | |
|------------------|---------------------------------|
| Name | OEN_1 |
| Relative Address | 0x00000248 |
| Absolute Address | 0xE000A248 |
| Width | 22 bits |
| Access Type | rw |
| Reset Value | 0x00000000 |
| Description | Output enable (GPIO Bank1, MIO) |

Register OEN_1 Details

This register operates in exactly the same manner as OEN_0, except that it reflects bank1, which corresponds to MIO[53:32].

| Field Name | Bits | Type | Reset Value | Description |
|-------------|------|------|-------------|---|
| OP_ENABLE_1 | 21:0 | rw | 0x0 | Operation is the same as OEN_0[OP_ENABLE_0] |

Register ([gpio](#)) INT_MASK_1

| | |
|------------------|---|
| Name | INT_MASK_1 |
| Relative Address | 0x0000024C |
| Absolute Address | 0xE000A24C |
| Width | 22 bits |
| Access Type | ro |
| Reset Value | 0x00000000 |
| Description | Interrupt Mask Status (GPIO Bank1, MIO) |

Register INT_MASK_1 Details

This register operates in exactly the same manner as INT_MASK_0, except that it reflects bank1, which corresponds to MIO[53:32].

| Field Name | Bits | Type | Reset Value | Description |
|------------|------|------|-------------|---|
| INT_MASK_1 | 21:0 | ro | 0x0 | Operation is the same as INT_MASK_0[INT_MASK_0] |

Register ([gpio](#)) INT_EN_1

| | |
|------------------|------------|
| Name | INT_EN_1 |
| Relative Address | 0x00000250 |

| | |
|------------------|---|
| Absolute Address | 0xE000A250 |
| Width | 22 bits |
| Access Type | wo |
| Reset Value | 0x00000000 |
| Description | Interrupt Enable/Unmask (GPIO Bank1, MIO) |

Register INT_EN_1 Details

This register operates in exactly the same manner as INT_EN_0, except that it reflects bank1, which corresponds to MIO[53:32].

| Field Name | Bits | Type | Reset Value | Description |
|--------------|------|------|-------------|---|
| INT_ENABLE_1 | 21:0 | wo | 0x0 | Operation is the same as INT_EN_0[INT_ENABLE_0] |

Register (gpio) INT_DIS_1

| | |
|------------------|--|
| Name | INT_DIS_1 |
| Relative Address | 0x00000254 |
| Absolute Address | 0xE000A254 |
| Width | 22 bits |
| Access Type | wo |
| Reset Value | 0x00000000 |
| Description | Interrupt Disable/Mask (GPIO Bank1, MIO) |

Register INT_DIS_1 Details

This register operates in exactly the same manner as INT_DIS_0, except that it reflects bank1, which corresponds to MIO[53:32].

| Field Name | Bits | Type | Reset Value | Description |
|---------------|------|------|-------------|---|
| INT_DISABLE_1 | 21:0 | wo | 0x0 | Operation is the same as INT_DIS_0[INT_DISABLE_0] |

Register (gpio) INT_STAT_1

| | |
|------------------|------------|
| Name | INT_STAT_1 |
| Relative Address | 0x00000258 |
| Absolute Address | 0xE000A258 |
| Width | 22 bits |
| Access Type | wtc |

Reset Value 0x00000000
 Description Interrupt Status (GPIO Bank1, MIO)

Register INT_STAT_1 Details

This register operates in exactly the same manner as INT_STAT_0, except that it reflects bank1, which corresponds to MIO[53:32].

| Field Name | Bits | Type | Reset Value | Description |
|--------------|------|------|-------------|---|
| INT_STATUS_1 | 21:0 | wtc | 0x0 | Operation is the same as INT_STAT_0[INT_STATUS_0] |

Register (gpio) INT_TYPE_1

Name INT_TYPE_1
 Relative Address 0x0000025C
 Absolute Address 0xE000A25C
 Width 22 bits
 Access Type rw
 Reset Value 0x003FFFFFFF
 Description Interrupt Type (GPIO Bank1, MIO)

Register INT_TYPE_1 Details

This register operates in exactly the same manner as INT_TYPE_0, except that it reflects bank1, which corresponds to MIO[53:32].

| Field Name | Bits | Type | Reset Value | Description |
|------------|------|------|-------------|---|
| INT_TYPE_1 | 21:0 | rw | 0x3FFFFFFF | Operation is the same as INT_TYPE_0[INT_TYPE_0] |

Register (gpio) INT_POLARITY_1

Name INT_POLARITY_1
 Relative Address 0x00000260
 Absolute Address 0xE000A260
 Width 22 bits
 Access Type rw
 Reset Value 0x00000000
 Description Interrupt Polarity (GPIO Bank1, MIO)

Register INT_POLARITY_1 Details

This register operates in exactly the same manner as INT_POLARITY_0, except that it reflects bank1, which corresponds to MIO[53:32].

| Field Name | Bits | Type | Reset Value | Description |
|------------|------|------|-------------|--|
| INT_POL_1 | 21:0 | rw | 0x0 | Operation is the same as INT_POLARITY_0[INT_POL_0] |

Register ([gpio](#)) INT_ANY_1

| | |
|------------------|--|
| Name | INT_ANY_1 |
| Relative Address | 0x00000264 |
| Absolute Address | 0xE000A264 |
| Width | 22 bits |
| Access Type | rw |
| Reset Value | 0x00000000 |
| Description | Interrupt Any Edge Sensitive (GPIO Bank1, MIO) |

Register INT_ANY_1 Details

This register operates in exactly the same manner as INT_ANY_0, except that it reflects bank1, which corresponds to MIO[53:32].

| Field Name | Bits | Type | Reset Value | Description |
|--------------|------|------|-------------|--|
| INT_ON_ANY_1 | 21:0 | rw | 0x0 | Operation is the same as INT_ANY_0[INT_ON_ANY_0] |

Register ([gpio](#)) DIRM_2

| | |
|------------------|-----------------------------------|
| Name | DIRM_2 |
| Relative Address | 0x00000284 |
| Absolute Address | 0xE000A284 |
| Width | 32 bits |
| Access Type | rw |
| Reset Value | 0x00000000 |
| Description | Direction mode (GPIO Bank2, EMIO) |

Register DIRM_2 Details

This register operates in exactly the same manner as DIRM_0, except that it reflects bank2, which corresponds to EMIO[31:0].

| Field Name | Bits | Type | Reset Value | Description |
|-------------|------|------|-------------|--|
| DIRECTION_2 | 31:0 | rw | 0x0 | Operation is the same as DIRM_0[DIRECTION_0] |

Register (gpio) OEN_2

| | |
|------------------|----------------------------------|
| Name | OEN_2 |
| Relative Address | 0x00000288 |
| Absolute Address | 0xE000A288 |
| Width | 32 bits |
| Access Type | rw |
| Reset Value | 0x00000000 |
| Description | Output enable (GPIO Bank2, EMIO) |

Register OEN_2 Details

This register operates in exactly the same manner as OEN_0, except that it reflects bank2, which corresponds to EMIO[31:0].

| Field Name | Bits | Type | Reset Value | Description |
|-------------|------|------|-------------|---|
| OP_ENABLE_2 | 31:0 | rw | 0x0 | Operation is the same as OEN_0[OP_ENABLE_0] |

Register (gpio) INT_MASK_2

| | |
|------------------|--|
| Name | INT_MASK_2 |
| Relative Address | 0x0000028C |
| Absolute Address | 0xE000A28C |
| Width | 32 bits |
| Access Type | ro |
| Reset Value | 0x00000000 |
| Description | Interrupt Mask Status (GPIO Bank2, EMIO) |

Register INT_MASK_2 Details

This register operates in exactly the same manner as INT_MASK_0, except that it reflects bank2, which corresponds to EMIO[31:0].

| Field Name | Bits | Type | Reset Value | Description |
|------------|------|------|-------------|---|
| INT_MASK_2 | 31:0 | ro | 0x0 | Operation is the same as INT_MASK_0[INT_MASK_0] |

Register ([gpio](#)) INT_EN_2

| | |
|------------------|--|
| Name | INT_EN_2 |
| Relative Address | 0x00000290 |
| Absolute Address | 0xE000A290 |
| Width | 32 bits |
| Access Type | wo |
| Reset Value | 0x00000000 |
| Description | Interrupt Enable/Unmask (GPIO Bank2, EMIO) |

Register INT_EN_2 Details

This register operates in exactly the same manner as INT_EN_0, except that it reflects bank2, which corresponds to EMIO[31:0].

| Field Name | Bits | Type | Reset Value | Description |
|--------------|------|------|-------------|---|
| INT_ENABLE_2 | 31:0 | wo | 0x0 | Operation is the same as INT_EN_0[INT_ENABLE_0] |

Register ([gpio](#)) INT_DIS_2

| | |
|------------------|---|
| Name | INT_DIS_2 |
| Relative Address | 0x00000294 |
| Absolute Address | 0xE000A294 |
| Width | 32 bits |
| Access Type | wo |
| Reset Value | 0x00000000 |
| Description | Interrupt Disable/Mask (GPIO Bank2, EMIO) |

Register INT_DIS_2 Details

This register operates in exactly the same manner as INT_DIS_0, except that it reflects bank2, which corresponds to EMIO[31:0].

| Field Name | Bits | Type | Reset Value | Description |
|---------------|------|------|-------------|---|
| INT_DISABLE_2 | 31:0 | wo | 0x0 | Operation is the same as INT_DIS_0[INT_DISABLE_0] |

Register ([gpio](#)) INT_STAT_2

| | |
|------|------------|
| Name | INT_STAT_2 |
|------|------------|

| | |
|------------------|-------------------------------------|
| Relative Address | 0x00000298 |
| Absolute Address | 0xE000A298 |
| Width | 32 bits |
| Access Type | wtc |
| Reset Value | 0x00000000 |
| Description | Interrupt Status (GPIO Bank2, EMIO) |

Register INT_STAT_2 Details

This register operates in exactly the same manner as INT_STAT_0, except that it reflects bank2, which corresponds to EMIO[31:0].

| Field Name | Bits | Type | Reset Value | Description |
|--------------|------|------|-------------|---|
| INT_STATUS_2 | 31:0 | wtc | 0x0 | Operation is the same as INT_STAT_0[INT_STATUS_0] |

Register ([gpio](#)) INT_TYPE_2

| | |
|------------------|-----------------------------------|
| Name | INT_TYPE_2 |
| Relative Address | 0x0000029C |
| Absolute Address | 0xE000A29C |
| Width | 32 bits |
| Access Type | rw |
| Reset Value | 0xFFFFFFFF |
| Description | Interrupt Type (GPIO Bank2, EMIO) |

Register INT_TYPE_2 Details

This register operates in exactly the same manner as INT_TYPE_0, except that it reflects bank2, which corresponds to EMIO[31:0].

| Field Name | Bits | Type | Reset Value | Description |
|------------|------|------|-------------|---|
| INT_TYPE_2 | 31:0 | rw | 0xFFFFFFFF | Operation is the same as INT_TYPE_0[INT_TYPE_0] |

Register ([gpio](#)) INT_POLARITY_2

| | |
|------------------|----------------|
| Name | INT_POLARITY_2 |
| Relative Address | 0x000002A0 |
| Absolute Address | 0xE000A2A0 |
| Width | 32 bits |
| Access Type | rw |

Reset Value 0x00000000
 Description Interrupt Polarity (GPIO Bank2, EMIO)

Register INT_POLARITY_2 Details

This register operates in exactly the same manner as INT_POLARITY_0, except that it reflects bank2, which corresponds to EMIO[31:0].

| Field Name | Bits | Type | Reset Value | Description |
|------------|------|------|-------------|--|
| INT_POL_2 | 31:0 | rw | 0x0 | Operation is the same as INT_POLARITY_0[INT_POL_0] |

Register (gpio) INT_ANY_2

Name INT_ANY_2
 Relative Address 0x000002A4
 Absolute Address 0xE000A2A4
 Width 32 bits
 Access Type rw
 Reset Value 0x00000000
 Description Interrupt Any Edge Sensitive (GPIO Bank2, EMIO)

Register INT_ANY_2 Details

This register operates in exactly the same manner as INT_ANY_0, except that it reflects bank2, which corresponds to EMIO[31:0].

| Field Name | Bits | Type | Reset Value | Description |
|--------------|------|------|-------------|--|
| INT_ON_ANY_2 | 31:0 | rw | 0x0 | Operation is the same as INT_ANY_0[INT_ON_ANY_0] |

Register (gpio) DIRM_3

Name DIRM_3
 Relative Address 0x000002C4
 Absolute Address 0xE000A2C4
 Width 32 bits
 Access Type rw
 Reset Value 0x00000000
 Description Direction mode (GPIO Bank3, EMIO)

Register DIRM_3 Details

This register operates in exactly the same manner as DIRM_0, except that it reflects bank3, which corresponds to EMIO[63:32].

| Field Name | Bits | Type | Reset Value | Description |
|-------------|------|------|-------------|--|
| DIRECTION_3 | 31:0 | rw | 0x0 | Operation is the same as DIRM_0[DIRECTION_0] |

Register (gpio) OEN_3

| | |
|------------------|----------------------------------|
| Name | OEN_3 |
| Relative Address | 0x000002C8 |
| Absolute Address | 0xE000A2C8 |
| Width | 32 bits |
| Access Type | rw |
| Reset Value | 0x00000000 |
| Description | Output enable (GPIO Bank3, EMIO) |

Register OEN_3 Details

This register operates in exactly the same manner as OEN_0, except that it reflects bank3, which corresponds to EMIO[63:32].

| Field Name | Bits | Type | Reset Value | Description |
|-------------|------|------|-------------|---|
| OP_ENABLE_3 | 31:0 | rw | 0x0 | Operation is the same as OEN_0[OP_ENABLE_0] |

Register (gpio) INT_MASK_3

| | |
|------------------|--|
| Name | INT_MASK_3 |
| Relative Address | 0x000002CC |
| Absolute Address | 0xE000A2CC |
| Width | 32 bits |
| Access Type | ro |
| Reset Value | 0x00000000 |
| Description | Interrupt Mask Status (GPIO Bank3, EMIO) |

Register INT_MASK_3 Details

This register operates in exactly the same manner as INT_MASK_0, except that it reflects bank3, which corresponds to EMIO[63:32].

| Field Name | Bits | Type | Reset Value | Description |
|------------|------|------|-------------|---|
| INT_MASK_3 | 31:0 | ro | 0x0 | Operation is the same as INT_MASK_0[INT_MASK_0] |

Register ([gpio](#)) INT_EN_3

| | |
|------------------|--|
| Name | INT_EN_3 |
| Relative Address | 0x000002D0 |
| Absolute Address | 0xE000A2D0 |
| Width | 32 bits |
| Access Type | wo |
| Reset Value | 0x00000000 |
| Description | Interrupt Enable/Unmask (GPIO Bank3, EMIO) |

Register INT_EN_3 Details

This register operates in exactly the same manner as INT_EN_0, except that it reflects bank3, which corresponds to EMIO[63:32].

| Field Name | Bits | Type | Reset Value | Description |
|--------------|------|------|-------------|---|
| INT_ENABLE_3 | 31:0 | wo | 0x0 | Operation is the same as INT_EN_0[INT_ENABLE_0] |

Register ([gpio](#)) INT_DIS_3

| | |
|------------------|---|
| Name | INT_DIS_3 |
| Relative Address | 0x000002D4 |
| Absolute Address | 0xE000A2D4 |
| Width | 32 bits |
| Access Type | wo |
| Reset Value | 0x00000000 |
| Description | Interrupt Disable/Mask (GPIO Bank3, EMIO) |

Register INT_DIS_3 Details

This register operates in exactly the same manner as INT_DIS_0, except that it reflects bank3, which corresponds to EMIO[63:32].

| Field Name | Bits | Type | Reset Value | Description |
|---------------|------|------|-------------|---|
| INT_DISABLE_3 | 31:0 | wo | 0x0 | Operation is the same as INT_DIS_0[INT_DISABLE_0] |

Register ([gpio](#)) INT_STAT_3

| | |
|------------------|-------------------------------------|
| Name | INT_STAT_3 |
| Relative Address | 0x000002D8 |
| Absolute Address | 0xE000A2D8 |
| Width | 32 bits |
| Access Type | wtc |
| Reset Value | 0x00000000 |
| Description | Interrupt Status (GPIO Bank3, EMIO) |

Register INT_STAT_3 Details

This register operates in exactly the same manner as INT_STAT_0, except that it reflects bank3, which corresponds to EMIO[63:32].

| Field Name | Bits | Type | Reset Value | Description |
|--------------|------|------|-------------|---|
| INT_STATUS_3 | 31:0 | wtc | 0x0 | Operation is the same as INT_STAT_0[INT_STATUS_0] |

Register ([gpio](#)) INT_TYPE_3

| | |
|------------------|-----------------------------------|
| Name | INT_TYPE_3 |
| Relative Address | 0x000002DC |
| Absolute Address | 0xE000A2DC |
| Width | 32 bits |
| Access Type | rw |
| Reset Value | 0xFFFFFFFF |
| Description | Interrupt Type (GPIO Bank3, EMIO) |

Register INT_TYPE_3 Details

This register operates in exactly the same manner as INT_TYPE_0, except that it reflects bank3, which corresponds to EMIO[63:32].

| Field Name | Bits | Type | Reset Value | Description |
|------------|------|------|-------------|---|
| INT_TYPE_3 | 31:0 | rw | 0xFFFFFFFF | Operation is the same as INT_TYPE_0[INT_TYPE_0] |

Register ([gpio](#)) INT_POLARITY_3

| | |
|------------------|----------------|
| Name | INT_POLARITY_3 |
| Relative Address | 0x000002E0 |

| | |
|------------------|---------------------------------------|
| Absolute Address | 0xE000A2E0 |
| Width | 32 bits |
| Access Type | rw |
| Reset Value | 0x00000000 |
| Description | Interrupt Polarity (GPIO Bank3, EMIO) |

Register INT_POLARITY_3 Details

This register operates in exactly the same manner as INT_POLARITY_0, except that it reflects bank3, which corresponds to EMIO[63:32].

| Field Name | Bits | Type | Reset Value | Description |
|------------|------|------|-------------|--|
| INT_POL_3 | 31:0 | rw | 0x0 | Operation is the same as INT_POLARITY_0[INT_POL_0] |

Register ([gpio](#)) INT_ANY_3

| | |
|------------------|---|
| Name | INT_ANY_3 |
| Relative Address | 0x000002E4 |
| Absolute Address | 0xE000A2E4 |
| Width | 32 bits |
| Access Type | rw |
| Reset Value | 0x00000000 |
| Description | Interrupt Any Edge Sensitive (GPIO Bank3, EMIO) |

Register INT_ANY_3 Details

This register operates in exactly the same manner as INT_ANY_0, except that it reflects bank3, which corresponds to EMIO[63:32].

| Field Name | Bits | Type | Reset Value | Description |
|--------------|------|------|-------------|--|
| INT_ON_ANY_3 | 31:0 | rw | 0x0 | Operation is the same as INT_ANY_0[INT_ON_ANY_0] |

B.20 Interconnect QoS (qos301)

| | |
|--------------|--|
| Module Name | Interconnect QoS (qos301) |
| Base Address | 0xF8946000 gpv_qos301_cpu 0xF8947000 gpv_qos301_dmac 0xF8948000 gpv_qos301_iou |
| Description | AMBA Network Interconnect Advanced Quality of Service (QoS-301) |
| Vendor Info | Arm QoS-301 |

Register Summary

| Register Name | Address | Width | Type | Reset Value | Description |
|-----------------------------|------------|-------|------|-------------|---|
| qos_cntl | 0x0000010C | 32 | rw | 0x00000000 | The QoS control register contains the enable bits for all the regulators. |
| max_ot | 0x00000110 | 32 | rw | 0x00000000 | Maximum number of outstanding transactions |
| max_comb_ot | 0x00000114 | 32 | rw | 0x00000000 | Maximum number of combined outstanding transactions |
| aw_p | 0x00000118 | 32 | rw | 0x00000000 | AW channel peak rate |
| aw_b | 0x0000011C | 32 | rw | 0x00000000 | AW channel burstiness allowance |
| aw_r | 0x00000120 | 32 | rw | 0x00000000 | AW channel average rate |
| ar_p | 0x00000124 | 32 | rw | 0x00000000 | AR channel peak rate |
| ar_b | 0x00000128 | 32 | rw | 0x00000000 | AR channel burstiness allowance |
| ar_r | 0x0000012C | 32 | rw | 0x00000000 | AR channel average rate |

Register ([qos301](#)) qos_cntl

| | |
|------------------|---|
| Name | qos_cntl |
| Relative Address | 0x0000010C |
| Absolute Address | gpv_qos301_cpu: 0xF894610C gpv_qos301_dmac: 0xF894710C gpv_qos301_iou: 0xF894810C |
| Width | 32 bits |
| Access Type | rw |
| Reset Value | 0x00000000 |
| Description | The QoS control register contains the enable bits for all the regulators. |

Register qos_cntl Details

By default, all of the bits are set to 0, and no regulation is enabled. Regulation only takes place when both the enable bit is set, and its corresponding regulation value is non-zero. The QoS regulators are reset whenever they are re-enabled.

| Field Name | Bits | Type | Reset Value | Description |
|--------------|------|------|-------------|---|
| en_awar_ot | 7 | rw | 0x0 | Enable combined regulation of outstanding transactions. |
| en_ar_ot | 6 | rw | 0x0 | Enable regulation of outstanding read transactions. |
| en_aw_ot | 5 | rw | 0x0 | Enable regulation of outstanding write transactions. |
| reserved | 4:3 | rw | 0x0 | Reserved |
| en_awar_rate | 2 | rw | 0x0 | Enable combined AW/AR rate regulation. |
| en_ar_rate | 1 | rw | 0x0 | Enable AR rate regulation. |
| en_aw_rate | 0 | rw | 0x0 | Enable AW rate regulation. |

Register ([qos301](#)) max_ot

| | |
|------------------|---|
| Name | max_ot |
| Relative Address | 0x00000110 |
| Absolute Address | gpv_qos301_cpu: 0xF8946110 gpv_qos301_dmac: 0xF8947110 gpv_qos301_iou: 0xF8948110 |
| Width | 32 bits |
| Access Type | rw |
| Reset Value | 0x00000000 |
| Description | Maximum number of outstanding transactions |

Register max_ot Details

The maximum number of outstanding transactions register enables you to program the maximum number of address requests for the AR and AW channels. The outstanding transaction limits have an integer part and a fractional part.

| Field Name | Bits | Type | Reset Value | Description |
|------------|-------|------|-------------|--|
| ar_max_oti | 29:24 | rw | 0x0 | Integer part of max outstanding AR addresses. |
| ar_max_otf | 23:16 | rw | 0x0 | Fraction part of max outstanding AR addresses. |
| aw_max_oti | 13:8 | rw | 0x0 | Integer part of max outstanding AW addresses. |
| aw_max_otf | 7:0 | rw | 0x0 | Fraction part of max outstanding AW addresses. |

A value of 0 for both the integer and fractional parts disables the programmable regulation so that the NIC-301 base product configuration limits apply.

A value of 0 for the fractional part programs disables the regulation of fractional outstanding transactions.

The AW and AR outstanding transaction limits are enabled when you set the corresponding en_aw_ot or en_ar_ot control bits of the QoS control register.

Register ([qos301](#)) max_comb_ot

| | |
|------------------|---|
| Name | max_comb_ot |
| Relative Address | 0x00000114 |
| Absolute Address | gpv_qos301_cpu: 0xF8946114 gpv_qos301_dmac: 0xF8947114 gpv_qos301_iou: 0xF8948114 |
| Width | 32 bits |
| Access Type | rw |
| Reset Value | 0x00000000 |
| Description | Maximum number of combined outstanding transactions |

Register max_comb_ot Details

The maximum combined outstanding transactions register enables you to program the maximum number of address requests for the AR and AW channels. The combined limit is applied after any individual channel limits.

| Field Name | Bits | Type | Reset Value | Description |
|--------------|------|------|-------------|--|
| awar_max_oti | 14:8 | rw | 0x0 | Integer part of max combined outstanding AW/AR addresses. |
| awar_max_otf | 7:0 | rw | 0x0 | Fraction part of max combined outstanding AW/AR addresses. |

A value of 0 for both the integer and fractional parts disables the programmable regulation so that the configuration limits apply.

A value of 0 for the fractional part programs disables the regulation of fractional outstanding transactions.

The regulation of the combined outstanding transaction limit also requires that you set the en_awar_ot control bit of the QoS control register.

Register ([qos301](#)) aw_p

| | |
|------------------|------------|
| Name | aw_p |
| Relative Address | 0x00000118 |

Absolute Address gpv_qos301_cpu: 0xF8946118
 gpv_qos301_dmac: 0xF8947118
 gpv_qos301_iou: 0xF8948118

Width 32 bits

Access Type rw

Reset Value 0x00000000

Description AW channel peak rate

Register aw_p Details

| Field Name | Bits | Type | Reset Value | Description |
|------------|-------|------|-------------|--|
| | 31:24 | rw | 0x0 | channel peak rate. 8-bit fraction of the number of transfers per cycle. A value of 0x80 (decimal 0.5) sets a rate of one transaction every 2 cycles. A value of 0x40 sets a rate of one transaction every 4 cycles, etc. |

Register ([qos301](#)) aw_b

Name aw_b

Relative Address 0x0000011C

Absolute Address gpv_qos301_cpu: 0xF894611C
 gpv_qos301_dmac: 0xF894711C
 gpv_qos301_iou: 0xF894811C

Width 32 bits

Access Type rw

Reset Value 0x00000000

Description AW channel burstiness allowance

Register aw_b Details

| Field Name | Bits | Type | Reset Value | Description |
|------------|------|------|-------------|--|
| | 15:0 | rw | 0x0 | channel burstiness (integer number of transfers) |

Register ([qos301](#)) aw_r

Name aw_r

Relative Address 0x00000120

Absolute Address gpv_qos301_cpu: 0xF8946120
 gpv_qos301_dmac: 0xF8947120
 gpv_qos301_iou: 0xF8948120

Width 32 bits

Access Type rw
 Reset Value 0x00000000
 Description AW channel average rate

Register aw_r Details

| Field Name | Bits | Type | Reset Value | Description |
|------------|-------|------|-------------|--|
| | 31:20 | rw | 0x0 | channel average rate. 12-bit fraction of the number of transfers per cycle. A value of 0x800 (decimal 0.5) sets a rate of one transaction every 2 cycles. A value of 0x400 sets a rate of one transaction every 4 cycles, etc. |

Register ([qos301](#)) ar_p

Name ar_p
 Relative Address 0x00000124
 Absolute Address gpv_qos301_cpu: 0xF8946124
 gpv_qos301_dmac: 0xF8947124
 gpv_qos301_iou: 0xF8948124
 Width 32 bits
 Access Type rw
 Reset Value 0x00000000
 Description AR channel peak rate

Register ar_p Details

| Field Name | Bits | Type | Reset Value | Description |
|------------|-------|------|-------------|--|
| | 31:24 | rw | 0x0 | channel peak rate. 8-bit fraction of the number of transfers per cycle. A value of 0x80 (decimal 0.5) sets a rate of one transaction every 2 cycles. A value of 0x40 sets a rate of one transaction every 4 cycles, etc. |

Register ([qos301](#)) ar_b

Name ar_b
 Relative Address 0x00000128
 Absolute Address gpv_qos301_cpu: 0xF8946128
 gpv_qos301_dmac: 0xF8947128
 gpv_qos301_iou: 0xF8948128
 Width 32 bits

Access Type rw
 Reset Value 0x00000000
 Description AR channel burstiness allowance

Register ar_b Details

| Field Name | Bits | Type | Reset Value | Description |
|------------|------|------|-------------|--|
| | 15:0 | rw | 0x0 | channel burstiness (integer number of transfers) |

Register ([qos301](#)) ar_r

Name ar_r
 Relative Address 0x0000012C
 Absolute Address gpv_qos301_cpu: 0xF894612C
 gpv_qos301_dmac: 0xF894712C
 gpv_qos301_iou: 0xF894812C
 Width 32 bits
 Access Type rw
 Reset Value 0x00000000
 Description AR channel average rate

Register ar_r Details

| Field Name | Bits | Type | Reset Value | Description |
|------------|-------|------|-------------|--|
| | 31:20 | rw | 0x0 | channel average rate. 12-bit fraction of the number of transfers per cycle. A value of 0x800 (decimal 0.5) sets a rate of one transaction every 2 cycles. A value of 0x400 sets a rate of one transaction every 4 cycles, etc. |

Usage Example:

- Peak = 2 (or 1 in 128)
- Burstiness = 5
- Average = 10 (or 1 in 409)

This allows an issuing rate of 1 in 128 until the burstiness allowance of 5 outstanding transactions is reached. Then the average issuing rate of 1 in 409 takes effect until the number of outstanding transactions drops below 5.

B.21 NIC301 Address Region Control (nic301_addr_region_ctrl_registers)

| | |
|---------------|---|
| Module Name | NIC301 Address Region Control (nic301_addr_region_ctrl_registers) |
| Software Name | XARC |
| Base Address | 0xF8900000 gpv_trustzone |
| Description | AMBA NIC301 TrustZone. |
| Vendor Info | Arm |

Register Summary

| Register Name | Address | Width | Type | Reset Value | Description |
|----------------------------------|------------|-------|------|-------------|----------------------------|
| security_gp0_axi | 0x0000001C | 1 | wo | 0x00000000 | M_AXI_GP0 security setting |
| security_gp1_axi | 0x00000020 | 1 | wo | 0x00000000 | M_AXI_GP1 security setting |

Register ([nic301_addr_region_ctrl_registers](#)) security_gp0_axi

| | |
|------------------|----------------------------|
| Name | security_gp0_axi |
| Relative Address | 0x0000001C |
| Absolute Address | 0xF890001C |
| Width | 1 bits |
| Access Type | wo |
| Reset Value | 0x00000000 |
| Description | M_AXI_GP0 security setting |

Register security_gp0_axi Details

| Field Name | Bits | Type | Reset Value | Description |
|------------|------|------|-------------|--|
| gp0_axi | 0 | wo | 0x0 | Controls the transactions from M_AXI_GP0 to PL: 0 - Always secure 1 - Always non-secure. |

Register ([nic301_addr_region_ctrl_registers](#)) security_gp1_axi

| | |
|------------------|------------------|
| Name | security_gp1_axi |
| Relative Address | 0x00000020 |
| Absolute Address | 0xF8900020 |

Width 1 bits
 Access Type wo
 Reset Value 0x00000000
 Description M_AXI_GP1 security setting

Register security_gp1_axi Details

| Field Name | Bits | Type | Reset Value | Description |
|------------|------|------|-------------|--|
| gp1_axi | 0 | wo | 0x0 | Controls the transactions from M_AXI_GP1 to PL: 0 - Always secure 1 - Always non-secure. |

B.22 I2C Controller (IIC)

| | |
|---------------|------------------------------------|
| Module Name | I2C Controller (IIC) |
| Software Name | XIICPS |
| Base Address | 0xE0004000 i2c0 0xE0005000 i2c1 |
| Description | Inter Integrated Circuit (I2C) |
| Vendor Info | Cadence IIC |

Register Summary

| Register Name | Address | Width | Type | Reset Value | Description |
|--|------------|-------|-------|-------------|-------------------------------|
| XIICPS_CR_OFFSET | 0x00000000 | 16 | mixed | 0x00000000 | Control Register |
| XIICPS_SR_OFFSET | 0x00000004 | 16 | ro | 0x00000000 | Status register |
| XIICPS_ADDR_OFFSET | 0x00000008 | 16 | mixed | 0x00000000 | IIC Address register |
| XIICPS_DATA_OFFSET | 0x0000000C | 16 | mixed | 0x00000000 | IIC data register |
| XIICPS_ISR_OFFSET | 0x00000010 | 16 | mixed | 0x00000000 | IIC interrupt status register |
| XIICPS_TRANS_SIZE_OFFSET | 0x00000014 | 8 | rw | 0x00000000 | Transfer Size Register |
| XIICPS_SLV_PAUSE_OFFSET | 0x00000018 | 8 | mixed | 0x00000000 | Slave Monitor Pause Register |
| XIICPS_TIME_OUT_OFFSET | 0x0000001C | 8 | rw | 0x0000001F | Time out register |
| XIICPS_IMR_OFFSET | 0x00000020 | 16 | ro | 0x000002FF | Interrupt mask register |
| XIICPS_IER_OFFSET | 0x00000024 | 16 | mixed | 0x00000000 | Interrupt Enable Register |
| XIICPS_IDR_OFFSET | 0x00000028 | 16 | mixed | 0x00000000 | Interrupt Disable Register |

Register (IIC) XIICPS_CR_OFFSET

| | |
|------------------|--------------------------------------|
| Name | XIICPS_CR_OFFSET |
| Software Name | CR |
| Relative Address | 0x00000000 |
| Absolute Address | i2c0: 0xE0004000 i2c1: 0xE0005000 |
| Width | 16 bits |
| Access Type | mixed |
| Reset Value | 0x00000000 |
| Description | Control Register |

Register XIICPS_CR_OFFSET Details

| Field Name | Bits | Type | Reset Value | Description |
|---------------------------------------|-------|------|-------------|--|
| XIICPS_CR_DIV_A_MASK (DIV_A) | 15:14 | rw | 0x0 | Divisor for stage A clock divider. 0 - 3: Divides the input pclk frequency by divisor_a + 1. |
| XIICPS_CR_DIV_B_MASK (DIV_B) | 13:8 | rw | 0x0 | Divisor for stage B clock divider. 0 - 63 : Divides the output frequency from divisor_a by divisor_b + 1. |
| reserved | 7 | ro | 0x0 | Reserved, read as zero, ignored on write. |
| XIICPS_CR_CLR_FIFO_MASK (CLR_FIFO) | 6 | rw | 0x0 | 1 - initializes the FIFO to all zeros and clears the transfer size register except in master receive mode. Automatically gets cleared on the next APB clock after being set. |
| XIICPS_CR_SLVMON_MASK (SLVMON) | 5 | rw | 0x0 | Slave monitor mode 1 - monitor mode. 0 - normal operation. |
| XIICPS_CR_HOLD_MASK (HOLD) | 4 | rw | 0x0 | hold_bus 1 - when no more data is available for transmit or no more data can be received, hold the sclk line low until serviced by the host. 0 - allow the transfer to terminate as soon as all the data has been transmitted or received. |
| XIICPS_CR_ACKEN_MASK (ACKEN) | 3 | rw | 0x0 | This bit needs to be set to 1 1 - acknowledge enabled, ACK transmitted 0 - acknowledge disabled, NACK transmitted. |
| XIICPS_CR_NEA_MASK (NEA) | 2 | rw | 0x0 | Addressing mode: This bit is used in master mode only. 1 - normal (7-bit) address 0 - reserved |
| XIICPS_CR_MS_MASK (MS) | 1 | rw | 0x0 | Overall interface mode: 1 - master 0 - slave |
| XIICPS_CR_RD_WR_MASK (RD_WR) | 0 | rw | 0x0 | Direction of transfer: This bit is used in master mode only. 1 - master receiver 0 - master transmitter. |

Register (IIC) XIICPS_SR_OFFSET

Name XIICPS_SR_OFFSET
 Software Name SR
 Relative Address 0x00000004

Absolute Address i2c0: 0xE0004004
i2c1: 0xE0005004

Width 16 bits

Access Type ro

Reset Value 0x00000000

Description Status register

Register XIICPS_SR_OFFSET Details

| Field Name | Bits | Type | Reset Value | Description |
|------------------------------|------|------|-------------|---|
| reserved | 15:9 | ro | 0x0 | Reserved, read as zero, ignored on write. |
| XIICPS_SR_BA_MASK (BA) | 8 | ro | 0x0 | Bus Active 1 - ongoing transfer on the I2C bus. |
| XIICPS_SR_RXOVF_MASK (RXOVF) | 7 | ro | 0x0 | Receiver Overflow 1 - This bit is set whenever FIFO is full and a new byte is received. The new byte is not acknowledged and contents of the FIFO remains unchanged. |
| XIICPS_SR_TXDV_MASK (TXDV) | 6 | ro | 0x0 | Transmit Data Valid - SW should not use this to determine data completion, it is the RAW value on the interface. Please use COMP in the ISR. 1 - still a byte of data to be transmitted by the interface. |
| XIICPS_SR_RXDV_MASK (RXDV) | 5 | ro | 0x0 | Receiver Data Valid 1 - valid, new data to be read from the interface. |
| reserved | 4 | ro | 0x0 | Reserved, read as zero, ignored on write. |
| XIICPS_SR_RXRW_MASK (RXRW) | 3 | ro | 0x0 | RX read_write 1 - mode of the transmission received from a master. |
| reserved | 2:0 | ro | 0x0 | Reserved, read as zero, ignored on write. |

Register (IIC) XIICPS_ADDR_OFFSET

Name XIICPS_ADDR_OFFSET

Software Name ADDR

Relative Address 0x00000008

Absolute Address i2c0: 0xE0004008
i2c1: 0xE0005008

Width 16 bits

Access Type mixed

Reset Value 0x00000000

Description IIC Address register

Register XIICPS_ADDR_OFFSET Details

| Field Name | Bits | Type | Reset Value | Description |
|-------------------------|-------|------|-------------|---|
| reserved | 15:10 | ro | 0x0 | Reserved, read as zero, ignored on write. |
| XIICPS_ADDR_MASK (MASK) | 9:0 | rw | 0x0 | Address 0 - 1024: Normal addressing mode uses add[6:0]. Extended addressing mode uses add[9:0]. |

Register (IIC) XIICPS_DATA_OFFSET

Name XIICPS_DATA_OFFSET
 Software Name DATA
 Relative Address 0x0000000C
 Absolute Address i2c0: 0xE000400C
 i2c1: 0xE000500C
 Width 16 bits
 Access Type mixed
 Reset Value 0x00000000
 Description IIC data register

Register XIICPS_DATA_OFFSET Details

| Field Name | Bits | Type | Reset Value | Description |
|-------------------------|------|------|-------------|---|
| reserved | 15:8 | ro | 0x0 | |
| XIICPS_DATA_MASK (MASK) | 7:0 | rw | 0x0 | data 0 -255: When written to, the data register sets data to transmit. When read from, the data register reads the last received byte of data. |

Register (IIC) XIICPS_ISR_OFFSET

Name XIICPS_ISR_OFFSET
 Software Name ISR
 Relative Address 0x00000010
 Absolute Address i2c0: 0xE0004010
 i2c1: 0xE0005010
 Width 16 bits
 Access Type mixed
 Reset Value 0x00000000

Description IIC interrupt status register

Register XIICPS_ISR_OFFSET Details

| Field Name | Bits | Type | Reset Value | Description |
|---|-------|------|-------------|--|
| reserved | 15:10 | ro | 0x0 | Reserved, read as zero, ignored on write. |
| XIICPS_I XR_ARB_LOST_MASK (IXR_ARB_LOST) | 9 | wtc | 0x0 | arbitration lost 1 = master loses bus ownership during a transfer due to ongoing arbitration |
| reserved | 8 | ro | 0x0 | Reserved, read as zero, ignored on write. |
| XIICPS_I XR_RX_UNF_M ASK (IXR_RX_UNF) | 7 | wtc | 0x0 | FIFO receive underflow 1 = host attempts to read from the I2C data register more times than the value of the transfer size register plus one |
| XIICPS_I XR_TX_OVR_M ASK (IXR_TX_OVR) | 6 | wtc | 0x0 | FIFO transmit overflow 1 = host attempts to write to the I2C data register more times than the FIFO depth |
| XIICPS_I XR_RX_OVR_M ASK (IXR_RX_OVR) | 5 | wtc | 0x0 | Receive overflow 1 = This bit is set whenever FIFO is full and a new byte is received. The new byte is not acknowledged and contents of the FIFO remains unchanged. |
| XIICPS_I XR_SLV_RDY_M ASK (IXR_SLV_RDY) | 4 | wtc | 0x0 | Monitored slave ready 1 = addressed slave returns ACK. |
| XIICPS_I XR_TO_MASK (IXR_TO) | 3 | wtc | 0x0 | Transfer time out 1 = I2C sclk line is kept low for longer time |
| XIICPS_I XR_NACK_MAS K (IXR_NACK) | 2 | wtc | 0x0 | Transfer not acknowledged 1 = slave responds with a NACK or master terminates the transfer before all data is supplied |
| XIICPS_I XR_DATA_MAS K (IXR_DATA) | 1 | wtc | 0x0 | More data 1 = Data being sent or received |
| XIICPS_I XR_COMP_MAS K (IXR_COMP) | 0 | wtc | 0x0 | Transfer complete 1 = transfer is complete |

Register (IIC) XIICPS_TRANS_SIZE_OFFSET

Name XIICPS_TRANS_SIZE_OFFSET
 Software Name TRANS_SIZE
 Relative Address 0x00000014

| | |
|------------------|--------------------------------------|
| Absolute Address | i2c0: 0xE0004014 i2c1: 0xE0005014 |
| Width | 8 bits |
| Access Type | rw |
| Reset Value | 0x00000000 |
| Description | Transfer Size Register |

Register XIICPS_TRANS_SIZE_OFFSET Details

This register's meaning varies according to the operating mode as follows:

- * Master transmitter mode: number of data bytes still not transmitted minus one
- * Master receiver mode: number of data bytes that are still expected to be received
- * Slave transmitter mode: number of bytes remaining in the FIFO after the master terminates the transfer
- * Slave receiver mode: number of valid data bytes in the FIFO

This register is cleared if CLR_FIFO bit in the control register is set.

| Field Name | Bits | Type | Reset Value | Description |
|--------------------------------------|------|------|-------------|------------------------|
| XIICPS_TRANS_SIZE_M ASK (MASK) | 7:0 | rw | 0x0 | Transfer Size 0-255 |

Register (IIC) XIICPS_SLV_PAUSE_OFFSET

| | |
|------------------|--------------------------------------|
| Name | XIICPS_SLV_PAUSE_OFFSET |
| Software Name | SLV_PAUSE |
| Relative Address | 0x00000018 |
| Absolute Address | i2c0: 0xE0004018 i2c1: 0xE0005018 |
| Width | 8 bits |
| Access Type | mixed |
| Reset Value | 0x00000000 |
| Description | Slave Monitor Pause Register |

Register XIICPS_SLV_PAUSE_OFFSET Details

| Field Name | Bits | Type | Reset Value | Description |
|------------------------------|------|------|-------------|---|
| reserved | 7:4 | ro | 0x0 | Reserved, read as zero, ignored on write. |
| XIICPS_SLV_PAUSE_MASK (MASK) | 3:0 | rw | 0x0 | pause interval 0 - 7: pause interval |

Register (IIC) XIICPS_TIME_OUT_OFFSET

| | |
|------------------|--------------------------------------|
| Name | XIICPS_TIME_OUT_OFFSET |
| Software Name | TIME_OUT |
| Relative Address | 0x0000001C |
| Absolute Address | i2c0: 0xE000401C i2c1: 0xE000501C |
| Width | 8 bits |
| Access Type | rw |
| Reset Value | 0x0000001F |
| Description | Time out register |

Register XIICPS_TIME_OUT_OFFSET Details

| Field Name | Bits | Type | Reset Value | Description |
|-----------------------------|------|------|-------------|---|
| XIICPS_TIME_OUT_MASK (MASK) | 7:0 | rw | 0x1F | Time Out 255 - 31 : value of time out register |

Register (IIC) XIICPS_IMR_OFFSET

| | |
|------------------|--------------------------------------|
| Name | XIICPS_IMR_OFFSET |
| Software Name | IMR |
| Relative Address | 0x00000020 |
| Absolute Address | i2c0: 0xE0004020 i2c1: 0xE0005020 |
| Width | 16 bits |
| Access Type | ro |
| Reset Value | 0x000002FF |
| Description | Interrupt mask register |

Register XIICPS_IMR_OFFSET Details

Each bit in this register corresponds to a bit in the interrupt status register. If bit *i* in the interrupt mask register is set, the corresponding bit in the interrupt status register is ignored. Otherwise, an interrupt is generated whenever bit *i* in the interrupt status register is set.

Bits in this register are set through a write to the interrupt disable register and are cleared through a write to the interrupt enable register.

All mask bits are set and all interrupts are disabled after reset.

Interrupt mask register has the same format as the interrupt status register.

| Field Name | Bits | Type | Reset Value | Description |
|--|-------|------|-------------|---|
| reserved | 15:10 | ro | 0x0 | Reserved, read as zero, ignored on write. |
| XIICPS_IXR_ARB_LOST_MASK (IXR_ARB_LOST) | 9 | ro | 0x1 | arbitration lost 1 = Mask this interrupt 0 = unmask this interrupt |
| reserved | 8 | ro | 0x0 | Reserved, read as zero, ignored on write. |
| XIICPS_IXR_RX_UNF_MASK (IXR_RX_UNF) | 7 | ro | 0x1 | FIFO receive underflow 1 = Mask this interrupt 0 = unmask this interrupt |
| XIICPS_IXR_TX_OVR_MASK (IXR_TX_OVR) | 6 | ro | 0x1 | FIFO transmit overflow 1 = Mask this interrupt 0 = unmask this interrupt |
| XIICPS_IXR_RX_OVR_MASK (IXR_RX_OVR) | 5 | ro | 0x1 | Receive overflow 1 = Mask this interrupt 0 = unmask this interrupt |
| XIICPS_IXR_SLV_RDY_MASK (IXR_SLV_RDY) | 4 | ro | 0x1 | Monitored slave ready 1 = Mask this interrupt 0 = unmask this interrupt |
| XIICPS_IXR_TO_MASK (IXR_TO) | 3 | ro | 0x1 | Transfer time out 1 = Mask this interrupt 0 = unmask this interrupt |
| XIICPS_IXR_NACK_MASK (IXR_NACK) | 2 | ro | 0x1 | Transfer not acknowledged 1 = Mask this interrupt 0 = unmask this interrupt |
| XIICPS_IXR_DATA_MASK (IXR_DATA) | 1 | ro | 0x1 | More data 1 = Mask this interrupt 0 = unmask this interrupt |
| XIICPS_IXR_COMP_MASK (IXR_COMP) | 0 | ro | 0x1 | Transfer complete 1 = Mask this interrupt 0 = unmask this interrupt |

Register (IIC) XIICPS_IER_OFFSET

| | |
|------------------|--------------------------------------|
| Name | XIICPS_IER_OFFSET |
| Software Name | IER |
| Relative Address | 0x00000024 |
| Absolute Address | i2c0: 0xE0004024 i2c1: 0xE0005024 |
| Width | 16 bits |
| Access Type | mixed |
| Reset Value | 0x00000000 |
| Description | Interrupt Enable Register |

Register XIICPS_IER_OFFSET Details

This register has the same format as the interrupt status register.

Setting a bit in the interrupt enable register clears the corresponding mask bit in the interrupt mask register, effectively enabling corresponding interrupt to be generated.

| Field Name | Bits | Type | Reset Value | Description |
|--|-------|------|-------------|--|
| reserved | 15:10 | ro | 0x0 | Reserved, read as zero, ignored on write. |
| XIICPS_IXR_ARB_LOST_MASK (IXR_ARB_LOST) | 9 | wo | 0x0 | arbitration lost 1 = enable this interrupt |
| reserved | 8 | ro | 0x0 | Reserved, read as zero, ignored on write. |
| XIICPS_IXR_RX_UNF_MASK (IXR_RX_UNF) | 7 | wo | 0x0 | FIFO receive underflow 1 = enable this interrupt |
| XIICPS_IXR_TX_OVR_MASK (IXR_TX_OVR) | 6 | wo | 0x0 | FIFO transmit overflow 1 = enable this interrupt |
| XIICPS_IXR_RX_OVR_MASK (IXR_RX_OVR) | 5 | wo | 0x0 | Receive overflow 1 = enable this interrupt |
| XIICPS_IXR_SLV_RDY_MASK (IXR_SLV_RDY) | 4 | wo | 0x0 | Monitored slave ready 1 = enable this interrupt |
| XIICPS_IXR_TO_MASK (IXR_TO) | 3 | wo | 0x0 | Transfer time out 1 = enable this interrupt |
| XIICPS_IXR_NACK_MASK (IXR_NACK) | 2 | wo | 0x0 | Transfer not acknowledged 1 = enable this interrupt |

| Field Name | Bits | Type | Reset Value | Description |
|------------------------------------|------|------|-------------|---|
| XIICPS_IXR_DATA_MASK (IXR_DATA) | 1 | wo | 0x0 | More data 1 = enable this interrupt |
| XIICPS_IXR_COMP_MASK (IXR_COMP) | 0 | wo | 0x0 | Transfer complete Will be set when transfer is complete 1 = enable this interrupt |

Register (IIC) XIICPS_IDR_OFFSET

| | |
|------------------|--------------------------------------|
| Name | XIICPS_IDR_OFFSET |
| Software Name | IDR |
| Relative Address | 0x00000028 |
| Absolute Address | i2c0: 0xE0004028 i2c1: 0xE0005028 |
| Width | 16 bits |
| Access Type | mixed |
| Reset Value | 0x00000000 |
| Description | Interrupt Disable Register |

Register XIICPS_IDR_OFFSET Details

This register has the same format as the interrupt status register.

Setting a bit in the interrupt disable register sets the corresponding mask bit in the interrupt mask register, effectively disabling corresponding interrupt to be generated.

| Field Name | Bits | Type | Reset Value | Description |
|--|-------|------|-------------|--|
| reserved | 15:10 | ro | 0x0 | Reserved, read as zero, ignored on write. |
| XIICPS_IXR_ARB_LOST_MASK (IXR_ARB_LOST) | 9 | wo | 0x0 | arbitration lost 1 = disable this interrupt |
| reserved | 8 | ro | 0x0 | Reserved, read as zero, ignored on write. |
| XIICPS_IXR_RX_UNF_MASK (IXR_RX_UNF) | 7 | wo | 0x0 | FIFO receive underflow 1 = disable this interrupt |
| XIICPS_IXR_TX_OVR_MASK (IXR_TX_OVR) | 6 | wo | 0x0 | FIFO transmit overflow 1 = disable this interrupt |
| XIICPS_IXR_RX_OVR_MASK (IXR_RX_OVR) | 5 | wo | 0x0 | Receive overflow 1 = disable this interrupt |

| Field Name | Bits | Type | Reset Value | Description |
|--|------|------|-------------|--|
| XIICPS_IXR_SLV_RDY_MASK (IXR_SLV_RDY) | 4 | wo | 0x0 | Monitored slave ready 1 = disable this interrupt |
| XIICPS_IXR_TO_MASK (IXR_TO) | 3 | wo | 0x0 | Transfer time out 1 = disable this interrupt |
| XIICPS_IXR_NACK_MASK (IXR_NACK) | 2 | wo | 0x0 | Transfer not acknowledged 1 = disable this interrupt |
| XIICPS_IXR_DATA_MASK (IXR_DATA) | 1 | wo | 0x0 | Master Write or Slave Transmitter Master Read or Slave Receiver 1 = disable this interrupt |
| XIICPS_IXR_COMP_MASK (IXR_COMP) | 0 | wo | 0x0 | Transfer complete Will be set when transfer is complete 1 = disable this interrupt |

B.23 L2 Cache (L2Cpl310)

| | |
|--------------|---------------------|
| Module Name | L2 Cache (L2Cpl310) |
| Base Address | 0xF8F02000 l2cache |
| Description | L2 cache PL310 |
| Vendor Info | Arm |

Register Summary

| Register Name | Address | Width | Type | Reset Value | Description |
|---------------------------------------|------------|-------|-------|-------------|---|
| reg0_cache_id | 0x00000000 | 32 | mixed | 0x410000C8 | cache ID register, Returns the 32-bit device ID code it reads off the CACHEID input bus. The value is specified by the system integrator. Reset value: 0x410000c8 |
| reg0_cache_type | 0x00000004 | 32 | mixed | 0x9E300300 | cache type register, Returns the 32-bit cache type. Reset value: 0x1c100100 |
| reg1_control | 0x00000100 | 32 | mixed | 0x00000000 | control register, reset value: 0x0 |
| reg1_aux_control | 0x00000104 | 32 | mixed | 0x02060000 | auxiliary control register, reset value: 0x02020000 |
| reg1_tag_ram_control | 0x00000108 | 32 | mixed | 0x00000777 | Configures Tag RAM latencies |
| reg1_data_ram_control | 0x0000010C | 32 | mixed | 0x00000777 | configures data RAM latencies |
| reg2_ev_counter_ctrl | 0x00000200 | 32 | mixed | 0x00000000 | Permits the event counters to be enabled and reset. |
| reg2_ev_counter1_cfg | 0x00000204 | 32 | mixed | 0x00000000 | Enables event counter 1 to be driven by a specific event. Counter 1 increments when the event occurs. |
| reg2_ev_counter0_cfg | 0x00000208 | 32 | mixed | 0x00000000 | Enables event counter 0 to be driven by a specific event. Counter 0 increments when the event occurs. |
| reg2_ev_counter1 | 0x0000020C | 32 | rw | 0x00000000 | Enable the programmer to read off the counter value. The counter counts an event as specified by the Counter Configuration Registers. The counter can be preloaded if counting is disabled and reset by the Event Counter Control Register. |

| Register Name | Address | Width | Type | Reset Value | Description |
|--------------------------------------|------------|-------|-------|-------------|---|
| reg2_ev_counter0 | 0x00000210 | 32 | rw | 0x00000000 | Enable the programmer to read off the counter value. The counter counts an event as specified by the Counter Configuration Registers. The counter can be preloaded if counting is disabled and reset by the Event Counter Control Register. |
| reg2_int_mask | 0x00000214 | 32 | mixed | 0x00000000 | This register enables or masks interrupts from being triggered on the external pins of the cache controller. Figure 3-8 on page 3-17 shows the register bit assignments. The bit assignments enables the masking of the interrupts on both their individual outputs and the combined L2CCINTR line. Clearing a bit by writing a 0, disables the interrupt triggering on that pin. All bits are cleared by a reset. You must write to the register bits with a 1 to enable the generation of interrupts. 1 = Enabled. 0 = Masked. This is the default. |
| reg2_int_mask_status | 0x00000218 | 32 | mixed | 0x00000000 | This register is a read-only. It returns the masked interrupt status. This register can be accessed by secure and non-secure operations. The register gives an AND function of the raw interrupt status with the values of the interrupt mask register. All the bits are cleared by a reset. A write to this register is ignored. Bits read can be HIGH or LOW: HIGH If the bits read HIGH, they reflect the status of the input lines triggering an interrupt. LOW If the bits read LOW, either no interrupt has been generated, or the interrupt is masked. |

| Register Name | Address | Width | Type | Reset Value | Description |
|-------------------------------------|------------|-------|-------|-------------|---|
| reg2_int_raw_status | 0x0000021C | 32 | mixed | 0x00000000 | The Raw Interrupt Status Register enables the interrupt status that excludes the masking logic. Bits read can be HIGH or LOW: HIGH If the bits read HIGH, they reflect the status of the input lines triggering an interrupt. LOW If the bits read LOW, no interrupt has been generated. |
| reg2_int_clear | 0x00000220 | 32 | mixed | 0x00000000 | Clears the Raw Interrupt Status Register bits. When a bit is written as 1, it clears the corresponding bit in the Raw Interrupt Status Register. When a bit is written as 0, it has no effect |
| reg7_cache_sync | 0x00000730 | 32 | mixed | 0x00000000 | Drain the STB. Operation complete when all buffers, LRB, LFB, STB, and EB, are empty |
| reg7_inv_pa | 0x00000770 | 32 | mixed | 0x00000000 | Invalidate Line by PA: Specific L2 cache line is marked as not valid |
| reg7_inv_way | 0x0000077C | 32 | mixed | 0x00000000 | Invalidate by Way Invalidate all data in specified ways, including dirty data. An Invalidate by way while selecting all cache ways is equivalent to invalidating all cache entries. Completes as a background task with the way, or ways, locked, preventing allocation. |
| reg7_clean_pa | 0x000007B0 | 32 | mixed | 0x00000000 | Clean Line by PA Write the specific L2 cache line to L3 main memory if the line is marked as valid and dirty. The line is marked as not dirty. The valid bit is unchanged |
| reg7_clean_index | 0x000007B8 | 32 | mixed | 0x00000000 | Clean Line by Set/Way Write the specific L2 cache line within the specified way to L3 main memory if the line is marked as valid and dirty. The line is marked as not dirty. The valid bit is unchanged |

| Register Name | Address | Width | Type | Reset Value | Description |
|--------------------------------------|------------|-------|-------|-------------|---|
| reg7_clean_way | 0x000007BC | 32 | mixed | 0x00000000 | Clean by Way Writes each line of the specified L2 cache ways to L3 main memory if the line is marked as valid and dirty. The lines are marked as not dirty. The valid bits are unchanged. Completes as a background task with the way, or ways, locked, preventing allocation. |
| reg7_clean_inv_pa | 0x000007F0 | 32 | mixed | 0x00000000 | Clean and Invalidate Line by PA Write the specific L2 cache line to L3 main memory if the line is marked as valid and dirty. The line is marked as not valid |
| reg7_clean_inv_index | 0x000007F8 | 32 | mixed | 0x00000000 | Clean and Invalidate Line by Set/Way Write the specific L2 cache line within the specified way to L3 main memory if the line is marked as valid and dirty. The line is marked as not valid |
| reg7_clean_inv_way | 0x000007FC | 32 | mixed | 0x00000000 | Clean and Invalidate by Way Writes each line of the specified L2 cache ways to L3 main memory if the line is marked as valid and dirty. The lines are marked as not valid. Completes as a background task with the way, or ways, locked, preventing allocation. |
| reg9_d_lockdown0 | 0x00000900 | 32 | mixed | 0x00000000 | All reg9 registers can prevent new addresses from being allocated and can also prevent data from being evicted out of the L2 cache. Each register pair (reg9_d_lockdown<n>, reg9_i_lockdown<n>) is for accesses coming from a particular master. Each bit of each register sets lockdown for a corresponding way, i.e. bit 0 for way 0, bit 1 for way 1, etc. 0 allocation can occur in the corresponding way. 1 there is no allocation in the corresponding way. |
| reg9_i_lockdown0 | 0x00000904 | 32 | mixed | 0x00000000 | instruction lock down 0 |
| reg9_d_lockdown1 | 0x00000908 | 32 | mixed | 0x00000000 | data lock down 1 |

| Register Name | Address | Width | Type | Reset Value | Description |
|--|------------|-------|-------|-------------|--|
| reg9_i_lockdown1 | 0x0000090C | 32 | mixed | 0x00000000 | instruction lock down 1 |
| reg9_d_lockdown2 | 0x00000910 | 32 | mixed | 0x00000000 | data lock down 2 |
| reg9_i_lockdown2 | 0x00000914 | 32 | mixed | 0x00000000 | instruction lock down 2 |
| reg9_d_lockdown3 | 0x00000918 | 32 | mixed | 0x00000000 | data lock down 3 |
| reg9_i_lockdown3 | 0x0000091C | 32 | mixed | 0x00000000 | instruction lock down 3 |
| reg9_d_lockdown4 | 0x00000920 | 32 | mixed | 0x00000000 | data lock down 4 |
| reg9_i_lockdown4 | 0x00000924 | 32 | mixed | 0x00000000 | instruction lock down 4 |
| reg9_d_lockdown5 | 0x00000928 | 32 | mixed | 0x00000000 | data lock down 5 |
| reg9_i_lockdown5 | 0x0000092C | 32 | mixed | 0x00000000 | instruction lock down 5 |
| reg9_d_lockdown6 | 0x00000930 | 32 | mixed | 0x00000000 | data lock down 6 |
| reg9_i_lockdown6 | 0x00000934 | 32 | mixed | 0x00000000 | instruction lock down 6 |
| reg9_d_lockdown7 | 0x00000938 | 32 | mixed | 0x00000000 | data lock down 7 |
| reg9_i_lockdown7 | 0x0000093C | 32 | mixed | 0x00000000 | instruction lock down 7 |
| reg9_lock_line_en | 0x00000950 | 32 | mixed | 0x00000000 | Lockdown by Line Enable Register. |
| reg9_unlock_way | 0x00000954 | 32 | mixed | 0x00000000 | Cache lockdown by way To control the cache lockdown by way and the cache lockdown by master mechanisms see the tables from Table 3-20 to Table 3-35 on page 3-31. For these tables each bit has the following meaning: 0 allocation can occur in the corresponding way. 1 there is no allocation in the corresponding way. |
| reg12_addr_filtering_start | 0x00000C00 | 32 | mixed | 0x40000001 | When two masters are implemented, you can redirect a whole address range to master 1 (M1). When address_filtering_enable is set, all accesses with address \geq address_filtering_start and $<$ address_filtering_end are automatically directed to M1. All other accesses are directed to M0. This feature is programmed using two registers. |

| Register Name | Address | Width | Type | Reset Value | Description |
|---|------------|-------|-------|-------------|--|
| reg12_addr_filtering_enable | 0x00000C04 | 32 | mixed | 0xFFFF0000 | When two masters are implemented, you can redirect a whole address range to master 1 (M1). When address_filtering_enable is set, all accesses with address >= address_filtering_start and <address_filtering_end are automatically directed to M1. All other accesses are directed to M0. This feature is programmed using two registers. |
| reg15_debug_ctrl | 0x00000F40 | 32 | mixed | 0x00000000 | The Debug Control Register forces specific cache behavior required for debug. This register has read-only, non-secure, or read and write, secure, permission. Any secure access and non-secure access can read this register. Only a secure access can write to this register. If a non-secure access tries to write to this register the register issues a DECERR response and does not update. |
| reg15_prefetch_ctrl | 0x00000F60 | 32 | mixed | 0x00000000 | Purpose Enables prefetch-related features that can improve system performance. Usage constraints This register has both read-only, non-secure, and read and write, secure, permissions. Any secure or non-secure access can read this register. Only a secure access can write to this register. If a non-secure access attempts to write to this register, the register |
| reg15_power_ctrl | 0x00000F80 | 32 | mixed | 0x00000000 | Purpose Controls the operating mode clock and power modes. Usage constraints There are no usage constraints. |

Register ([L2Cpl310](#)) reg0_cache_id

Name reg0_cache_id

Relative Address 0x00000000
 Absolute Address 0xF8F02000
 Width 32 bits
 Access Type mixed
 Reset Value 0x410000C8
 Description cache ID register, Returns the 32-bit device ID code it reads off the CACHEID input bus.
 The value is specified by the system integrator. Reset value: 0x410000c8

Register reg0_cache_id Details

| Field Name | Bits | Type | Reset Value | Description |
|-------------|-------|------|-------------|------------------|
| implementer | 31:24 | ro | 0x41 | 0x41, Arm |
| reserved | 23:16 | waz | 0x0 | reserved |
| cache_id | 15:10 | ro | 0x0 | cache id |
| part_num | 9:6 | ro | 0x3 | part number |
| rtl_release | 5:0 | ro | 0x8 | RTL release R3p2 |

Register (L2Cp1310) reg0_cache_type

Name reg0_cache_type
 Relative Address 0x00000004
 Absolute Address 0xF8F02004
 Width 32 bits
 Access Type mixed
 Reset Value 0x9E300300
 Description cache type register, Returns the 32-bit cache type. Reset value: 0x1c100100

Register reg0_cache_type Details

| Field Name | Bits | Type | Reset Value | Description |
|--------------|-------|------|-------------|---|
| data_banking | 31 | ro | 0x1 | 0 = Data banking not implemented. 1 = Data banking implemented. |
| reserved | 30:29 | waz | 0x0 | reserved |
| ctype | 28:25 | ro | 0xF | 11xy, where: x=1 if pl310_LOCKDOWN_BY_MASTER is defined, otherwise 0 y=1 if pl310_LOCKDOWN_BY_LINE is defined, otherwise 0. |
| H | 24 | ro | 0x0 | unified |

| Field Name | Bits | Type | Reset Value | Description |
|--------------------|-------|---------|-------------|--|
| Dsize_23 | 23 | waz,raz | 0x0 | fixed to 0 |
| Dsize_mid | 22:20 | ro | 0x3 | L2 cache way size Read from Auxiliary Control Register 19 through 17 |
| Dsize_19 | 19 | waz,raz | 0x0 | fixed to 0 |
| L2_assoc_D | 18 | ro | 0x0 | Read from Auxiliary Control Register bit 16 |
| reserved | 17:14 | waz | 0x0 | reserved |
| l2cache_line_len_D | 13:12 | ro | 0x0 | L2 cache line length - 00-32 bytes |
| lsize_11 | 11 | waz,raz | 0x0 | fixed to 0 |
| lsize_mid | 10:8 | ro | 0x3 | L2 cache way size Read from Auxiliary Control Register[19:17] |
| lsize_7 | 7 | waz,raz | 0x0 | fixed to 0 |
| L2_assoc_l | 6 | ro | 0x0 | Read from Auxiliary Control Register bit 16 |
| reserved | 5:2 | waz | 0x0 | reserved |
| l2cache_line_len_l | 1:0 | ro | 0x0 | L2 cache line length - 00-32 bytes |

Register ([L2Cpl310](#)) reg1_control

| | |
|------------------|------------------------------------|
| Name | reg1_control |
| Relative Address | 0x00000100 |
| Absolute Address | 0xF8F02100 |
| Width | 32 bits |
| Access Type | mixed |
| Reset Value | 0x00000000 |
| Description | control register, reset value: 0x0 |

Register reg1_control Details

| Field Name | Bits | Type | Reset Value | Description |
|------------|------|---------|-------------|--|
| reserved | 30:1 | waz,raz | 0x0 | reserved, reserved |
| l2_enable | 0 | rw | 0x0 | 0 = L2 Cache is disabled. This is the default value. 1 = L2 Cache is enabled. |

Register ([L2Cpl310](#)) reg1_aux_control

| | |
|------|------------------|
| Name | reg1_aux_control |
|------|------------------|

Relative Address 0x00000104
 Absolute Address 0xF8F02104
 Width 32 bits
 Access Type mixed
 Reset Value 0x02060000
 Description auxiliary control register, reset value: 0x02020000

Register reg1_aux_control Details

| Field Name | Bits | Type | Reset Value | Description |
|-------------------------|------|---------|-------------|---|
| reserved | 31 | waz,raz | 0x0 | reserved, reserved |
| early_bresp_en | 30 | rw | 0x0 | Early BRESP enable 0 = Early BRESP disabled. This is the default. 1 = Early BRESP enabled. |
| instr_prefetch_en | 29 | rw | 0x0 | Instruction prefetch enable 0 = Instruction prefetching disabled. This is the default. 1 = Instruction prefetching enabled. |
| data_prefetch_en | 28 | rw | 0x0 | Data prefetch enable 0 = Data prefetching disabled. This is the default. 1 = Data prefetching enabled. |
| nonsec_inte_access_ctrl | 27 | rw | 0x0 | Non-secure interrupt access control 0 = The reg2_int_mask register (at offset address 0x214) and the reg2_int_clear register (at offset address 0x220) can be modified or read with only secure accesses. This is the default. 1 = The reg2_int_mask register (at offset address 0x214) and the reg2_int_clear register (at offset address 0x220) can be modified or read with secure or non-secure accesses. |
| nonsec_lockdown_en | 26 | rw | 0x0 | Non-secure lockdown enable 0 = Lockdown registers cannot be modified using non-secure accesses. This is the default. 1 = Non-secure accesses can write to the lockdown registers. |
| cache_replace_policy | 25 | rw | 0x1 | Cache replacement policy 0 = pseudo-random replacement using lfsr. 1 = round-robin replacement. This is the default. |

| Field Name | Bits | Type | Reset Value | Description |
|-------------------------|-------|---------|-------------|---|
| force_write_alloc | 24:23 | rw | 0x0 | Force write allocate b00 = Use AWCACHE attributes for WA. This is the default. b01 = Force no allocate, set WA bit always 0. b10 = Override AWCACHE attributes, set WA bit always 1, all cacheable write misses become write allocated. b11 = Internally mapped to 00. See Cache operation on page 2-11 for more information. |
| shared_attr_override_en | 22 | rw | 0x0 | Shared attribute override enable 0 = Treats shared accesses as specified in Shareable attribute on page 2-15. This is the default. 1 = Shared attribute internally ignored. |
| parity_en | 21 | rw | 0x0 | Parity enable 0 = Disabled. This is the default. 1 = Enabled |
| event_mon_bus_en | 20 | rw | 0x0 | Event monitor bus enable 0 = Disabled. This is the default. 1 = Enabled |
| way_size | 19:17 | rw | 0x3 | Way-size b000 = Reserved, internally mapped to 16KB. b001 = 16KB. b010 = 32KB. b011 = 64KB. b100 = 128KB. b101 = 256KB. b110 = 512KB. b111 = Reserved, internally mapped to 512 KB. |
| associativity | 16 | rw | 0x0 | Associativity 0 = 8-way. 1 = 16-way. |
| reserved | 15:14 | waz,raz | 0x0 | reserved, reserved |
| shared_attr_inva_en | 13 | rw | 0x0 | Shared Attribute Invalidate Enable 0 = Shared invalidate behavior disabled. This is the default. 1 = Shared invalidate behavior enabled, if Shared Attribute Override Enable bit not set. See Shareable attribute on page 2-15. |
| ex_cache_config | 12 | rw | 0x0 | Exclusive cache configuration 0 = Disabled. This is the default. 1 = Enabled, |

| Field Name | Bits | Type | Reset Value | Description |
|-----------------------|------|---------|-------------|---|
| store_buff_dev_lim_en | 11 | rw | 0x0 | Store buffer device limitation Enable 0 = Store buffer device limitation disabled. Device writes can take all slots in store buffer. This is the default. 1 = Store buffer device limitation enabled. Device writes cannot take all slots in store buffer when connected to the Cortex-A9 MPCore processor. There is always one available slot to service Normal Memory |
| high_pr_so_dev_rd_en | 10 | rw | 0x0 | High Priority for SO and Dev Reads Enable 0 = Strongly Ordered and Device reads have lower priority than cacheable accesses when arbitrated in the L2CC (L2C-310) master ports. This is the default. 1 = Strongly Ordered and Device reads get the highest priority when arbitrated in the L2CC (L2C-310) master ports. |
| reserved | 9:1 | waz,raz | 0x0 | reserved, reserved |
| full_line_zero_enable | 0 | rw | 0x0 | Full Line of Zero Enable 0 = Full line of write zero behavior disabled. This is the default. 1 = Full line of write zero behavior Enabled. |

Register ([L2Cpl310](#)) `reg1_tag_ram_control`

| | |
|------------------|------------------------------|
| Name | reg1_tag_ram_control |
| Relative Address | 0x00000108 |
| Absolute Address | 0xF8F02108 |
| Width | 32 bits |
| Access Type | mixed |
| Reset Value | 0x00000777 |
| Description | Configures Tag RAM latencies |

Register reg1_tag_ram_control Details

| Field Name | Bits | Type | Reset Value | Description |
|-------------------|-------|---------|-------------|--|
| reserved | 31:11 | waz,raz | 0x0 | reserved, reserved |
| ram_wr_access_lat | 10:8 | rw | 0x7 | RAM write access latency Default value depends on the value of pl310_TAG_WRITE_LAT b000 = 1 cycle of latency, there is no additional latency. b001 = 2 cycles of latency. b010 = 3 cycles of latency. b011 = 4 cycles of latency. b100 = 5 cycles of latency. b101 = 6 cycles of latency. b110 = 7 cycles of latency. b111 = 8 cycles of latency |
| reserved | 7 | waz,raz | 0x0 | reserved, reserved |
| ram_rd_access_lat | 6:4 | rw | 0x7 | RAM read access latency Default value depends on the value of pl310_TAG_READ_LAT b000 = 1 cycle of latency, there is no additional latency. b001 = 2 cycles of latency. b010 = 3 cycles of latency. b011 = 4 cycles of latency. b100 = 5 cycles of latency. b101 = 6 cycles of latency. b110 = 7 cycles of latency. b111 = 8 cycles of latency. |
| reserved | 3 | waz,raz | 0x0 | reserved, reserved |
| ram_setup_lat | 2:0 | rw | 0x7 | RAM setup latency Default value depends on the value of pl310_TAG_SETUP_LAT b000 = 1 cycle of latency, there is no additional latency. b001 = 2 cycles of latency. b010 = 3 cycles of latency. b011 = 4 cycles of latency. b100 = 5 cycles of latency. b101 = 6 cycles of latency. b110 = 7 cycles of latency. b111 = 8 cycles of latency. |

Register ([L2Cpl310](#)) reg1_data_ram_control

Name reg1_data_ram_control
Relative Address 0x0000010C

Absolute Address 0xF8F0210C
 Width 32 bits
 Access Type mixed
 Reset Value 0x00000777
 Description configures data RAM latencies

Register reg1_data_ram_control Details

| Field Name | Bits | Type | Reset Value | Description |
|-------------------|-------|---------|-------------|---|
| reserved | 31:11 | waz,raz | 0x0 | reserved, reserved |
| ram_wr_access_lat | 10:8 | rw | 0x7 | RAM write access latency Default value depends on the value of pl310_DATA_WRITE_LAT b000 = 1 cycle of latency, there is no additional latency. b001 = 2 cycles of latency. b010 = 3 cycles of latency. b011 = 4 cycles of latency. b100 = 5 cycles of latency. b101 = 6 cycles of latency. b110 = 7 cycles of latency. b111 = 8 cycles of latency |
| reserved | 7 | waz,raz | 0x0 | reserved, reserved |
| ram_rd_access_lat | 6:4 | rw | 0x7 | RAM read access latency Default value depends on the value of pl310_DATA_READ_LAT b000 = 1 cycle of latency, there is no additional latency. b001 = 2 cycles of latency. b010 = 3 cycles of latency. b011 = 4 cycles of latency. b100 = 5 cycles of latency. b101 = 6 cycles of latency. b110 = 7 cycles of latency. b111 = 8 cycles of latency. |

| Field Name | Bits | Type | Reset Value | Description |
|---------------|------|---------|-------------|---|
| reserved | 3 | waz,raz | 0x0 | reserved, reserved |
| ran_setup_lat | 2:0 | rw | 0x7 | RAM setup latency Default value depends on the value of pl310_DATA_SETUP_LAT b000 = 1 cycle of latency, there is no additional latency. b001 = 2 cycles of latency. b010 = 3 cycles of latency. b011 = 4 cycles of latency. b100 = 5 cycles of latency. b101 = 6 cycles of latency. b110 = 7 cycles of latency. b111 = 8 cycles of latency. |

Register ([L2Cpl310](#)) reg2_ev_counter_ctrl

| | |
|------------------|---|
| Name | reg2_ev_counter_ctrl |
| Relative Address | 0x00000200 |
| Absolute Address | 0xF8F02200 |
| Width | 32 bits |
| Access Type | mixed |
| Reset Value | 0x00000000 |
| Description | Permits the event counters to be enabled and reset. |

Register reg2_ev_counter_ctrl Details

| Field Name | Bits | Type | Reset Value | Description |
|---------------|------|---------|-------------|---|
| reserved | 31:3 | waz,raz | 0x0 | reserved, reserved |
| counter_reset | 2:1 | raz,rw | 0x0 | Always Read as zero. The following counters are reset when a 1 is written to the following bits: bit[2] = Event Counter1 reset bit[1] = Event Counter0 reset. |
| ev_ctr_en | 0 | rw | 0x0 | Event counter enable 0 = Event Counting Disable. This is the default. 1 = Event Counting Enable. |

Register ([L2Cpl310](#)) reg2_ev_counter1_cfg

| | |
|------------------|----------------------|
| Name | reg2_ev_counter1_cfg |
| Relative Address | 0x00000204 |
| Absolute Address | 0xF8F02204 |

Width 32 bits
 Access Type mixed
 Reset Value 0x00000000
 Description Enables event counter 1 to be driven by a specific event. Counter 1 increments when the event occurs.

Register reg2_ev_counter1_cfg Details

| Field Name | Bits | Type | Reset Value | Description |
|-----------------|------|---------|-------------|--|
| reserved | 31:6 | waz,raz | 0x0 | reserved, reserved |
| ctr_ev_src | 5:2 | rw | 0x0 | Counter event source Event Encoding Counter Disabled b0000 CO b0001 DRHIT b0010 DRREQ b0011 DWHIT b0100 DWREQ b0101 DWTREQ b0110 IRHIT b0111 IRREQ b1000 WA b1001 IPFALLOC b1010 EPFHIT b1011 EPFALLOC b1100 SRRCVD b1101 SRCONF b1110 EPFRCVD b1111 |
| ev_ctr_intr_gen | 1:0 | rw | 0x0 | Event counter interrupt generation b00 = Disabled. This is the default. b01 = Enabled: Increment condition. b10 = Enabled: Overflow condition. b11 = Interrupt generation is disabled. |

Register ([L2Cpl310](#)) reg2_ev_counter0_cfg

Name reg2_ev_counter0_cfg
 Relative Address 0x00000208
 Absolute Address 0xF8F02208
 Width 32 bits
 Access Type mixed
 Reset Value 0x00000000
 Description Enables event counter 0 to be driven by a specific event. Counter 0 increments when the event occurs.

Register reg2_ev_counter0_cfg Details

| Field Name | Bits | Type | Reset Value | Description |
|-----------------|------|---------|-------------|--|
| reserved | 31:6 | waz,raz | 0x0 | reserved, reserved |
| ctr_ev_src | 5:2 | rw | 0x0 | Counter event source Event Encoding Counter Disabled b0000 CO b0001 DRHIT b0010 DRREQ b0011 DWHIT b0100 DWREQ b0101 DWTREQ b0110 IRHIT b0111 IRREQ b1000 WA b1001 IPFALLOC b1010 EPFHIT b1011 EPFALLOC b1100 SRRCVD b1101 SRCONF b1110 EPFRCVD b1111 |
| ev_ctr_intr_gen | 1:0 | rw | 0x0 | Event counter interrupt generation b00 = Disabled. This is the default. b01 = Enabled: Increment condition. b10 = Enabled: Overflow condition. b11 = Interrupt generation is disabled. |

Register ([L2Cpl310](#)) reg2_ev_counter1

| | |
|------------------|---|
| Name | reg2_ev_counter1 |
| Relative Address | 0x0000020C |
| Absolute Address | 0xF8F0220C |
| Width | 32 bits |
| Access Type | rw |
| Reset Value | 0x00000000 |
| Description | Enable the programmer to read off the counter value. The counter counts an event as specified by the Counter Configuration Registers. The counter can be preloaded if counting is disabled and reset by the Event Counter Control Register. |

Register reg2_ev_counter1 Details

| Field Name | Bits | Type | Reset Value | Description |
|-------------|------|------|-------------|---|
| counter_val | 31:0 | rw | 0x0 | Total of the event selected. If a counter reaches its maximum value, it saturates at that value until it is reset. |

Register (L2Cpl310) reg2_ev_counter0

| | |
|------------------|---|
| Name | reg2_ev_counter0 |
| Relative Address | 0x00000210 |
| Absolute Address | 0xF8F02210 |
| Width | 32 bits |
| Access Type | rw |
| Reset Value | 0x00000000 |
| Description | Enable the programmer to read off the counter value. The counter counts an event as specified by the Counter Configuration Registers. The counter can be preloaded if counting is disabled and reset by the Event Counter Control Register. |

Register reg2_ev_counter0 Details

| Field Name | Bits | Type | Reset Value | Description |
|-------------|------|------|-------------|---|
| counter_val | 31:0 | rw | 0x0 | Total of the event selected. If a counter reaches its maximum value, it saturates at that value until it is reset. |

Register (L2Cpl310) reg2_int_mask

| | |
|------------------|---------------|
| Name | reg2_int_mask |
| Relative Address | 0x00000214 |
| Absolute Address | 0xF8F02214 |
| Width | 32 bits |
| Access Type | mixed |
| Reset Value | 0x00000000 |

Description This register enables or masks interrupts from being triggered on the external pins of the cache controller. Figure 3-8 on page 3-17 shows the register bit assignments. The bit assignments enables the masking of the interrupts on both their individual outputs and the combined L2CCINTR line. Clearing a bit by writing a 0, disables the interrupt triggering on that pin. All bits are cleared by a reset. You must write to the register bits with a 1 to enable the generation of interrupts.

1 = Enabled.
0 = Masked. This is the default.

Register reg2_int_mask Details

| Field Name | Bits | Type | Reset Value | Description |
|------------|------|---------|-------------|--|
| reserved | 31:9 | waz,raz | 0x0 | reserved, reserved |
| DECERR | 8 | rw | 0x0 | DECERR: DECERR from L3 |
| SLVERR | 7 | rw | 0x0 | SLVERR: SLVERR from L3 |
| ERRRD | 6 | rw | 0x0 | ERRRD: Error on L2 data RAM, Read |
| ERRRT | 5 | rw | 0x0 | ERRRT: Error on L2 tag RAM, Read |
| ERRWD | 4 | rw | 0x0 | ERRWD: Error on L2 data RAM, Write |
| ERRWT | 3 | rw | 0x0 | ERRWT: Error on L2 tag RAM, Write |
| PARRD | 2 | rw | 0x0 | PARRD: Parity Error on L2 data RAM, Read |
| PARRT | 1 | rw | 0x0 | PARRT: Parity Error on L2 tag RAM, Read |
| ECNTR | 0 | rw | 0x0 | ECNTR: Event Counter1/0 Overflow Increment |

Register ([L2Cpl310](#)) reg2_int_mask_status

Name reg2_int_mask_status

Relative Address 0x00000218

Absolute Address 0xF8F02218

Width 32 bits

Access Type mixed

Reset Value 0x00000000

Description This register is a read-only. It returns the masked interrupt status. This register can be accessed by secure and non-secure operations. The register gives an AND function of the raw interrupt status with the values of the interrupt mask register. All the bits are cleared by a reset. A write to this register is ignored. Bits read can be HIGH or LOW:
 HIGH If the bits read HIGH, they reflect the status of the input lines triggering an interrupt.
 LOW If the bits read LOW, either no interrupt has been generated, or the interrupt is masked.

Register reg2_int_mask_status Details

| Field Name | Bits | Type | Reset Value | Description |
|------------|------|------|-------------|--|
| reserved | 31:9 | raz | 0x0 | reserved |
| DECERR | 8 | ro | 0x0 | DECERR: DECERR from L3 |
| SLVERR | 7 | ro | 0x0 | SLVERR: SLVERR from L3 |
| ERRRD | 6 | ro | 0x0 | ERRRD: Error on L2 data RAM, Read |
| ERRRT | 5 | ro | 0x0 | ERRRT: Error on L2 tag RAM, Read |
| ERRWD | 4 | ro | 0x0 | ERRWD: Error on L2 data RAM, Write |
| ERRWT | 3 | ro | 0x0 | ERRWT: Error on L2 tag RAM, Write |
| PARRD | 2 | ro | 0x0 | PARRD: Parity Error on L2 data RAM, Read |
| PARRT | 1 | ro | 0x0 | PARRT: Parity Error on L2 tag RAM, Read |
| ECNTR | 0 | ro | 0x0 | ECNTR: Event Counter1/0 Overflow Increment |

Register ([L2Cpl310](#)) reg2_int_raw_status

| | |
|------------------|--|
| Name | reg2_int_raw_status |
| Relative Address | 0x0000021C |
| Absolute Address | 0xF8F0221C |
| Width | 32 bits |
| Access Type | mixed |
| Reset Value | 0x00000000 |
| Description | <p>The Raw Interrupt Status Register enables the interrupt status that excludes the masking logic.</p> <p>Bits read can be HIGH or LOW:</p> <p>HIGH If the bits read HIGH, they reflect the status of the input lines triggering an interrupt.</p> <p>LOW If the bits read LOW, no interrupt has been generated.</p> |

Register reg2_int_raw_status Details

| Field Name | Bits | Type | Reset Value | Description |
|------------|------|------|-------------|--|
| reserved | 31:9 | raz | 0x0 | reserved |
| DECERR | 8 | ro | 0x0 | DECERR: DECERR from L3 |
| SLVERR | 7 | ro | 0x0 | SLVERR: SLVERR from L3 |
| ERRRD | 6 | ro | 0x0 | ERRRD: Error on L2 data RAM, Read |
| ERRRT | 5 | ro | 0x0 | ERRRT: Error on L2 tag RAM, Read |
| ERRWD | 4 | ro | 0x0 | ERRWD: Error on L2 data RAM, Write |
| ERRWT | 3 | ro | 0x0 | ERRWT: Error on L2 tag RAM, Write |
| PARRD | 2 | ro | 0x0 | PARRD: Parity Error on L2 data RAM, Read |

| Field Name | Bits | Type | Reset Value | Description |
|------------|------|------|-------------|--|
| PARRT | 1 | ro | 0x0 | PARRT: Parity Error on L2 tag RAM, Read |
| ECNTR | 0 | ro | 0x0 | ECNTR: Event Counter1/0 Overflow Increment |

Register ([L2Cpl310](#)) reg2_int_clear

| | |
|------------------|--|
| Name | reg2_int_clear |
| Relative Address | 0x00000220 |
| Absolute Address | 0xF8F02220 |
| Width | 32 bits |
| Access Type | mixed |
| Reset Value | 0x00000000 |
| Description | Clears the Raw Interrupt Status Register bits. When a bit is written as 1, it clears the corresponding bit in the Raw Interrupt Status Register. When a bit is written as 0, it has no effect |

Register reg2_int_clear Details

| Field Name | Bits | Type | Reset Value | Description |
|------------|------|------|-------------|--|
| reserved | 31:9 | raz | 0x0 | reserved |
| DECERR | 8 | wtc | 0x0 | DECERR: DECERR from L3 |
| SLVERR | 7 | wtc | 0x0 | SLVERR: SLVERR from L3 |
| ERRRD | 6 | wtc | 0x0 | ERRRD: Error on L2 data RAM, Read |
| ERRRT | 5 | wtc | 0x0 | ERRRT: Error on L2 tag RAM, Read |
| ERRWD | 4 | wtc | 0x0 | ERRWD: Error on L2 data RAM, Write |
| ERRWT | 3 | wtc | 0x0 | ERRWT: Error on L2 tag RAM, Write |
| PARRD | 2 | wtc | 0x0 | PARRD: Parity Error on L2 data RAM, Read |
| PARRT | 1 | wtc | 0x0 | PARRT: Parity Error on L2 tag RAM, Read |
| ECNTR | 0 | wtc | 0x0 | ECNTR: Event Counter1/0 Overflow Increment |

Register ([L2Cpl310](#)) reg7_cache_sync

| | |
|------------------|--|
| Name | reg7_cache_sync |
| Relative Address | 0x00000730 |
| Absolute Address | 0xF8F02730 |
| Width | 32 bits |
| Access Type | mixed |
| Reset Value | 0x00000000 |
| Description | Drain the STB. Operation complete when all buffers, LRB, LFB, STB, and EB, are empty |

Register reg7_cache_sync Details

| Field Name | Bits | Type | Reset Value | Description |
|------------|------|------|-------------|---|
| reserved | 31:1 | waz | 0x0 | reserved |
| c | 0 | rw | 0x0 | Cache Sync: Drain the STB. Operation complete when all buffers, LRB, LFB, STB, and EB, are empty. |

Register ([L2Cpl310](#)) reg7_inv_pa

| | |
|------------------|--|
| Name | reg7_inv_pa |
| Relative Address | 0x00000770 |
| Absolute Address | 0xF8F02770 |
| Width | 32 bits |
| Access Type | mixed |
| Reset Value | 0x00000000 |
| Description | Invalidate Line by PA: Specific L2 cache line is marked as not valid |

Register reg7_inv_pa Details

| Field Name | Bits | Type | Reset Value | Description |
|------------|-------|------|-------------|--|
| tag | 31:12 | rw | 0x0 | tag |
| index | 11:5 | rw | 0x0 | index |
| reserved | 4:1 | waz | 0x0 | reserved |
| c | 0 | rw | 0x0 | C Flag When written must be 0. When read, indicates that a background operation is in progress |

Register ([L2Cpl310](#)) reg7_inv_way

| | |
|------------------|--|
| Name | reg7_inv_way |
| Relative Address | 0x0000077C |
| Absolute Address | 0xF8F0277C |
| Width | 32 bits |
| Access Type | mixed |
| Reset Value | 0x00000000 |
| Description | Invalidate by Way Invalidate all data in specified ways, including dirty data. An Invalidate by way while selecting all cache ways is equivalent to invalidating all cache entries. Completes as a background task with the way, or ways, locked, preventing allocation. |

Register reg7_inv_way Details

| Field Name | Bits | Type | Reset Value | Description |
|------------|------|------|-------------|---|
| reserved | 31:8 | waz | 0x0 | reserved |
| way_bits | 7:0 | rw | 0x0 | way bits: You can select multiple ways at the same time, by setting the Way bits to 1 |

Register (L2Cpl310) reg7_clean_pa

| | |
|------------------|--|
| Name | reg7_clean_pa |
| Relative Address | 0x000007B0 |
| Absolute Address | 0xF8F027B0 |
| Width | 32 bits |
| Access Type | mixed |
| Reset Value | 0x00000000 |
| Description | Clean Line by PA Write the specific L2 cache line to L3 main memory if the line is marked as valid and dirty. The line is marked as not dirty. The valid bit is unchanged |

Register reg7_clean_pa Details

| Field Name | Bits | Type | Reset Value | Description |
|------------|-------|------|-------------|--|
| tag | 31:12 | rw | 0x0 | tag |
| index | 11:5 | rw | 0x0 | index |
| reserved | 4:1 | waz | 0x0 | reserved |
| c | 0 | rw | 0x0 | C Flag When written must be 0. When read, indicates that a background operation is in progress |

Register (L2Cpl310) reg7_clean_index

| | |
|------------------|---|
| Name | reg7_clean_index |
| Relative Address | 0x000007B8 |
| Absolute Address | 0xF8F027B8 |
| Width | 32 bits |
| Access Type | mixed |
| Reset Value | 0x00000000 |
| Description | Clean Line by Set/Way Write the specific L2 cache line within the specified way to L3 main memory if the line is marked as valid and dirty. The line is marked as not dirty. The valid bit is unchanged |

Register reg7_clean_index Details

| Field Name | Bits | Type | Reset Value | Description |
|------------|-------|------|-------------|-------------|
| reserved | 31 | waz | 0x0 | reserved |
| way | 30:28 | rw | 0x0 | way |
| reserved | 27:12 | waz | 0x0 | reserved |
| index | 11:5 | rw | 0x0 | index |
| reserved | 4:1 | waz | 0x0 | reserved |
| c | 0 | rw | 0x0 | c |

Register ([L2Cpl310](#)) reg7_clean_way

| | |
|------------------|--|
| Name | reg7_clean_way |
| Relative Address | 0x000007BC |
| Absolute Address | 0xF8F027BC |
| Width | 32 bits |
| Access Type | mixed |
| Reset Value | 0x00000000 |
| Description | Clean by Way Writes each line of the specified L2 cache ways to L3 main memory if the line is marked as valid and dirty. The lines are marked as not dirty. The valid bits are unchanged. Completes as a background task with the way, or ways, locked, preventing allocation. |

Register reg7_clean_way Details

| Field Name | Bits | Type | Reset Value | Description |
|------------|------|------|-------------|---|
| reserved | 31:8 | waz | 0x0 | reserved |
| way_bits | 7:0 | rw | 0x0 | way bits: You can select multiple ways at the same time, by setting the Way bits to 1 |

Register ([L2Cpl310](#)) reg7_clean_inv_pa

| | |
|------------------|-------------------|
| Name | reg7_clean_inv_pa |
| Relative Address | 0x000007F0 |
| Absolute Address | 0xF8F027F0 |
| Width | 32 bits |
| Access Type | mixed |
| Reset Value | 0x00000000 |

Description Clean and Invalidate Line by PA Write the specific L2 cache line to L3 main memory if the line is marked as valid and dirty. The line is marked as not valid

Register reg7_clean_inv_pa Details

| Field Name | Bits | Type | Reset Value | Description |
|------------|-------|------|-------------|--|
| tag | 31:12 | rw | 0x0 | tag |
| index | 11:5 | rw | 0x0 | index |
| reserved | 4:1 | waz | 0x0 | reserved |
| c | 0 | rw | 0x0 | C Flag When written must be 0. When read, indicates that a background operation is in progress |

Register (L2Cpl310) reg7_clean_inv_index

Name reg7_clean_inv_index
 Relative Address 0x000007F8
 Absolute Address 0xF8F027F8
 Width 32 bits
 Access Type mixed
 Reset Value 0x00000000
 Description Clean and Invalidate Line by Set/Way Write the specific L2 cache line within the specified way to L3 main memory if the line is marked as valid and dirty. The line is marked as not valid

Register reg7_clean_inv_index Details

| Field Name | Bits | Type | Reset Value | Description |
|------------|-------|------|-------------|-------------|
| reserved | 31 | waz | 0x0 | reserved |
| way | 30:28 | rw | 0x0 | way |
| reserved | 27:12 | waz | 0x0 | reserved |
| index | 11:5 | rw | 0x0 | index |
| reserved | 4:1 | waz | 0x0 | reserved |
| c | 0 | rw | 0x0 | c |

Register (L2Cpl310) reg7_clean_inv_way

Name reg7_clean_inv_way
 Relative Address 0x000007FC

| | |
|------------------|---|
| Absolute Address | 0xF8F027FC |
| Width | 32 bits |
| Access Type | mixed |
| Reset Value | 0x00000000 |
| Description | Clean and Invalidate by Way Writes each line of the specified L2 cache ways to L3 main memory if the line is marked as valid and dirty. The lines are marked as not valid. Completes as a background task with the way, or ways, locked, preventing allocation. |

Register reg7_clean_inv_way Details

| Field Name | Bits | Type | Reset Value | Description |
|------------|------|------|-------------|---|
| reserved | 31:8 | waz | 0x0 | reserved |
| way_bits | 7:0 | rw | 0x0 | way bits: You can select multiple ways at the same time, by setting the Way bits to 1 |

Register ([L2Cpl310](#)) reg9_d_lockdown0

| | |
|------------------|---|
| Name | reg9_d_lockdown0 |
| Relative Address | 0x00000900 |
| Absolute Address | 0xF8F02900 |
| Width | 32 bits |
| Access Type | mixed |
| Reset Value | 0x00000000 |
| Description | All reg9 registers can prevent new addresses from being allocated and can also prevent data from being evicted out of the L2 cache. Each register pair (reg9_d_lockdown<n>, reg9_i_lockdown<n>) is for accesses coming from a particular master. Each bit of each register sets lockdown for a corresponding way, i.e. bit 0 for way 0, bit 1 for way 1, etc. 0 allocation can occur in the corresponding way. 1 there is no allocation in the corresponding way. |

Register reg9_d_lockdown0 Details

| Field Name | Bits | Type | Reset Value | Description |
|-------------|-------|-------------|-------------|---------------------|
| reserved | 31:16 | waz,ra z | 0x0 | reserved |
| DATALOCK000 | 15:0 | rw | 0x0 | Use for master CPU0 |

Register ([L2Cpl310](#)) reg9_i_lockdown0

| | |
|------------------|-------------------------|
| Name | reg9_i_lockdown0 |
| Relative Address | 0x00000904 |
| Absolute Address | 0xF8F02904 |
| Width | 32 bits |
| Access Type | mixed |
| Reset Value | 0x00000000 |
| Description | instruction lock down 0 |

Register reg9_i_lockdown0 Details

| Field Name | Bits | Type | Reset Value | Description |
|--------------|-------|---------|-------------|---------------------|
| reserved | 31:16 | waz,raz | 0x0 | reserved |
| INSTRLOCK000 | 15:0 | rw | 0x0 | Use for master CPU0 |

Register ([L2Cpl310](#)) reg9_d_lockdown1

| | |
|------------------|------------------|
| Name | reg9_d_lockdown1 |
| Relative Address | 0x00000908 |
| Absolute Address | 0xF8F02908 |
| Width | 32 bits |
| Access Type | mixed |
| Reset Value | 0x00000000 |
| Description | data lock down 1 |

Register reg9_d_lockdown1 Details

| Field Name | Bits | Type | Reset Value | Description |
|-------------|-------|---------|-------------|---------------------|
| reserved | 31:16 | waz,raz | 0x0 | reserved |
| DATALOCK001 | 15:0 | rw | 0x0 | Use for master CPU1 |

Register ([L2Cpl310](#)) reg9_i_lockdown1

| | |
|------------------|------------------|
| Name | reg9_i_lockdown1 |
| Relative Address | 0x0000090C |
| Absolute Address | 0xF8F0290C |
| Width | 32 bits |

Access Type mixed
 Reset Value 0x00000000
 Description instruction lock down 1

Register reg9_i_lockdown1 Details

| Field Name | Bits | Type | Reset Value | Description |
|--------------|-------|-------------|-------------|---------------------|
| reserved | 31:16 | waz,ra z | 0x0 | reserved |
| INSTRLOCK001 | 15:0 | rw | 0x0 | Use for master CPU1 |

Register ([L2Cpl310](#)) reg9_d_lockdown2

Name reg9_d_lockdown2
 Relative Address 0x00000910
 Absolute Address 0xF8F02910
 Width 32 bits
 Access Type mixed
 Reset Value 0x00000000
 Description data lock down 2

Register reg9_d_lockdown2 Details

| Field Name | Bits | Type | Reset Value | Description |
|------------|-------|-------------|-------------|-------------|
| reserved | 31:16 | waz,ra z | 0x0 | reserved |
| reserved | 15:0 | rw | 0x0 | reserved |

Register ([L2Cpl310](#)) reg9_i_lockdown2

Name reg9_i_lockdown2
 Relative Address 0x00000914
 Absolute Address 0xF8F02914
 Width 32 bits
 Access Type mixed
 Reset Value 0x00000000
 Description instruction lock down 2

Register reg9_i_lockdown2 Details

| Field Name | Bits | Type | Reset Value | Description |
|------------|-------|-------------|-------------|-------------|
| reserved | 31:16 | waz,ra z | 0x0 | reserved |
| reserved | 15:0 | rw | 0x0 | reserved |

Register (L2Cpl310) reg9_d_lockdown3

| | |
|------------------|------------------|
| Name | reg9_d_lockdown3 |
| Relative Address | 0x00000918 |
| Absolute Address | 0xF8F02918 |
| Width | 32 bits |
| Access Type | mixed |
| Reset Value | 0x00000000 |
| Description | data lock down 3 |

Register reg9_d_lockdown3 Details

| Field Name | Bits | Type | Reset Value | Description |
|------------|-------|-------------|-------------|-------------|
| reserved | 31:16 | waz,ra z | 0x0 | reserved |
| reserved | 15:0 | rw | 0x0 | reserved |

Register (L2Cpl310) reg9_i_lockdown3

| | |
|------------------|-------------------------|
| Name | reg9_i_lockdown3 |
| Relative Address | 0x0000091C |
| Absolute Address | 0xF8F0291C |
| Width | 32 bits |
| Access Type | mixed |
| Reset Value | 0x00000000 |
| Description | instruction lock down 3 |

Register reg9_i_lockdown3 Details

| Field Name | Bits | Type | Reset Value | Description |
|------------|-------|-------------|-------------|-------------|
| reserved | 31:16 | waz,ra z | 0x0 | reserved |
| reserved | 15:0 | rw | 0x0 | reserved |

Register ([L2Cpl310](#)) reg9_d_lockdown4

Name reg9_d_lockdown4
 Relative Address 0x00000920
 Absolute Address 0xF8F02920
 Width 32 bits
 Access Type mixed
 Reset Value 0x00000000
 Description data lock down 4

Register reg9_d_lockdown4 Details

| Field Name | Bits | Type | Reset Value | Description |
|-------------|-------|---------|-------------|---|
| reserved | 31:16 | waz,raz | 0x0 | reserved |
| DATALOCK100 | 15:0 | rw | 0x0 | Use for ACP master with SAXIACPaxID[2:1]=00 |

Register ([L2Cpl310](#)) reg9_i_lockdown4

Name reg9_i_lockdown4
 Relative Address 0x00000924
 Absolute Address 0xF8F02924
 Width 32 bits
 Access Type mixed
 Reset Value 0x00000000
 Description instruction lock down 4

Register reg9_i_lockdown4 Details

| Field Name | Bits | Type | Reset Value | Description |
|--------------|-------|---------|-------------|---|
| reserved | 31:16 | waz,raz | 0x0 | reserved |
| INSTRLOCK100 | 15:0 | rw | 0x0 | Use for ACP master with SAXIACPaxID[2:1]=00 |

Register ([L2Cpl310](#)) reg9_d_lockdown5

Name reg9_d_lockdown5
 Relative Address 0x00000928
 Absolute Address 0xF8F02928
 Width 32 bits

Access Type mixed
 Reset Value 0x00000000
 Description data lock down 5

Register reg9_d_lockdown5 Details

| Field Name | Bits | Type | Reset Value | Description |
|-------------|-------|---------|-------------|---|
| reserved | 31:16 | waz,raz | 0x0 | reserved |
| DATALOCK101 | 15:0 | rw | 0x0 | Use for ACP master with SAXIACPaxID[2:1]=01 |

Register ([L2Cpl310](#)) reg9_i_lockdown5

Name reg9_i_lockdown5
 Relative Address 0x0000092C
 Absolute Address 0xF8F0292C
 Width 32 bits
 Access Type mixed
 Reset Value 0x00000000
 Description instruction lock down 5

Register reg9_i_lockdown5 Details

| Field Name | Bits | Type | Reset Value | Description |
|--------------|-------|---------|-------------|---|
| reserved | 31:16 | waz,raz | 0x0 | reserved |
| INSTRLOCK101 | 15:0 | rw | 0x0 | Use for ACP master with SAXIACPaxID[2:1]=01 |

Register ([L2Cpl310](#)) reg9_d_lockdown6

Name reg9_d_lockdown6
 Relative Address 0x00000930
 Absolute Address 0xF8F02930
 Width 32 bits
 Access Type mixed
 Reset Value 0x00000000
 Description data lock down 6

Register reg9_d_lockdown6 Details

| Field Name | Bits | Type | Reset Value | Description |
|-------------|-------|-------------|-------------|---|
| reserved | 31:16 | waz,ra z | 0x0 | reserved |
| DATALOCK110 | 15:0 | rw | 0x0 | Use for ACP master with SAXIACPAXID[2:1]=10 |

Register ([L2Cpl310](#)) reg9_i_lockdown6

| | |
|------------------|-------------------------|
| Name | reg9_i_lockdown6 |
| Relative Address | 0x00000934 |
| Absolute Address | 0xF8F02934 |
| Width | 32 bits |
| Access Type | mixed |
| Reset Value | 0x00000000 |
| Description | instruction lock down 6 |

Register reg9_i_lockdown6 Details

| Field Name | Bits | Type | Reset Value | Description |
|--------------|-------|-------------|-------------|---|
| reserved | 31:16 | waz,ra z | 0x0 | reserved |
| INSTRLOCK110 | 15:0 | rw | 0x0 | Use for ACP master with SAXIACPAXID[2:1]=10 |

Register ([L2Cpl310](#)) reg9_d_lockdown7

| | |
|------------------|------------------|
| Name | reg9_d_lockdown7 |
| Relative Address | 0x00000938 |
| Absolute Address | 0xF8F02938 |
| Width | 32 bits |
| Access Type | mixed |
| Reset Value | 0x00000000 |
| Description | data lock down 7 |

Register reg9_d_lockdown7 Details

| Field Name | Bits | Type | Reset Value | Description |
|-------------|-------|-------------|-------------|---|
| reserved | 31:16 | waz,ra z | 0x0 | reserved |
| DATALOCK111 | 15:0 | rw | 0x0 | Use for ACP master with SAXIACPAXID[2:1]=11 |

Register ([L2Cpl310](#)) reg9_i_lockdown7

Name reg9_i_lockdown7
 Relative Address 0x0000093C
 Absolute Address 0xF8F0293C
 Width 32 bits
 Access Type mixed
 Reset Value 0x00000000
 Description instruction lock down 7

Register reg9_i_lockdown7 Details

| Field Name | Bits | Type | Reset Value | Description |
|--------------|-------|---------|-------------|---|
| reserved | 31:16 | waz,raz | 0x0 | reserved |
| INSTRLOCK111 | 15:0 | rw | 0x0 | Use for ACP master with SAXIACPaxID[2:1]=11 |

Register ([L2Cpl310](#)) reg9_lock_line_en

Name reg9_lock_line_en
 Relative Address 0x00000950
 Absolute Address 0xF8F02950
 Width 32 bits
 Access Type mixed
 Reset Value 0x00000000
 Description Lockdown by Line Enable Register.

Register reg9_lock_line_en Details

| Field Name | Bits | Type | Reset Value | Description |
|--------------------------|------|---------|-------------|--|
| reserved | 31:1 | waz,raz | 0x0 | reserved |
| lock_down_by_line_enable | 0 | rw | 0x0 | 0 = Lockdown by line disabled. This is the default. 1 = Lockdown by line enabled. |

Register ([L2Cpl310](#)) reg9_unlock_way

Name reg9_unlock_way
 Relative Address 0x00000954
 Absolute Address 0xF8F02954

| | |
|-------------|--|
| Width | 32 bits |
| Access Type | mixed |
| Reset Value | 0x00000000 |
| Description | <p>Cache lockdown by way</p> <p>To control the cache lockdown by way and the cache lockdown by master mechanisms see the tables from Table 3-20 to Table 3-35 on page 3-31. For these tables each bit has the following meaning:</p> <p>0 allocation can occur in the corresponding way.</p> <p>1 there is no allocation in the corresponding way.</p> |

Register reg9_unlock_way Details

| Field Name | Bits | Type | Reset Value | Description |
|-----------------------------------|-------|---------|-------------|---|
| reserved | 31:16 | waz,raz | 0x0 | reserved |
| unlock_all_lines_by_way_operation | 15:0 | rw | 0x0 | For all bits: 0 = Unlock all lines disabled. This is the default. 1 = Unlock all lines operation in progress for the corresponding way. |

Register ([L2Cp1310](#)) reg12_addr_filtering_start

| | |
|------------------|--|
| Name | reg12_addr_filtering_start |
| Relative Address | 0x00000C00 |
| Absolute Address | 0xF8F02C00 |
| Width | 32 bits |
| Access Type | mixed |
| Reset Value | 0x40000001 |
| Description | <p>When two masters are implemented, you can redirect a whole address range to master 1 (M1).</p> <p>When address_filtering_enable is set, all accesses with address >= address_filtering_start and <address_filtering_end are automatically directed to M1. All other accesses are directed to M0.</p> <p>This feature is programmed using two registers.</p> |

Register reg12_addr_filtering_start Details

| Field Name | Bits | Type | Reset Value | Description |
|----------------------|-------|------|-------------|----------------------------------|
| addr_filtering_start | 31:20 | rw | 0x400 | Address filtering start address. |

| Field Name | Bits | Type | Reset Value | Description |
|-----------------------|------|---------|-------------|--|
| reserved | 19:1 | waz,raz | 0x0 | reserved |
| addr_filtering_enable | 0 | rw | 0x1 | 0 = Address filtering disabled. 1 = Address filtering enabled |

Register (L2Cpl310) reg12_addr_filtering_end

| | |
|------------------|--|
| Name | reg12_addr_filtering_end |
| Relative Address | 0x00000C04 |
| Absolute Address | 0xF8F02C04 |
| Width | 32 bits |
| Access Type | mixed |
| Reset Value | 0xFFF00000 |
| Description | <p>When two masters are implemented, you can redirect a whole address range to master 1 (M1).</p> <p>When address_filtering_enable is set, all accesses with address \geq address_filtering_start and $<$ address_filtering_end are automatically directed to M1. All other accesses are directed to M0.</p> <p>This feature is programmed using two registers.</p> |

Register reg12_addr_filtering_end Details

| Field Name | Bits | Type | Reset Value | Description |
|--------------------|-------|---------|-------------|--------------------------------|
| addr_filtering_end | 31:20 | rw | 0xFFF | Address filtering end address. |
| reserved | 19:0 | waz,raz | 0x0 | reserved |

Register (L2Cpl310) reg15_debug_ctrl

| | |
|------------------|------------------|
| Name | reg15_debug_ctrl |
| Relative Address | 0x00000F40 |
| Absolute Address | 0xF8F02F40 |
| Width | 32 bits |
| Access Type | mixed |
| Reset Value | 0x00000000 |

Description The Debug Control Register forces specific cache behavior required for debug. This register has read-only, non-secure, or read and write, secure, permission. Any secure access and non-secure access can read this register. Only a secure access can write to this register. If a non-secure access tries to write to this register the register issues a DECERR response and does not update.

Register reg15_debug_ctrl Details

| Field Name | Bits | Type | Reset Value | Description |
|------------|------|---------|-------------|--|
| reserved | 31:3 | waz,raz | 0x0 | reserved |
| SPNIDEN | 2 | rw | 0x0 | Reads value of SPNIDEN input. |
| DWB | 1 | rw | 0x0 | DWB: Disable write-back, force WT 0 = Enable write-back behavior. This is the default. 1 = Force write-through behavior |
| DCL | 0 | rw | 0x0 | DCL: Disable cache linefill 0 = Enable cache linefills. This is the default. 1 = Disable cache linefills. |

Register ([L2Cpl310](#)) reg15_prefetch_ctrl

Name reg15_prefetch_ctrl
 Relative Address 0x00000F60
 Absolute Address 0xF8F02F60
 Width 32 bits
 Access Type mixed
 Reset Value 0x00000000
 Description Purpose Enables prefetch-related features that can improve system performance. Usage constraints This register has both read-only, non-secure, and read and write, secure, permissions. Any secure or non-secure access can read this register. Only a secure access can write to this register. If a non-secure access attempts to write to this register, the register

Register reg15_prefetch_ctrl Details

| Field Name | Bits | Type | Reset Value | Description |
|---------------------------------|-------|---------|-------------|---|
| reserved | 31 | waz,raz | 0x0 | reserved |
| double_linefill_en | 30 | rw | 0x0 | Double linefill enable: You can set the following options for this register bit: 0 The L2CC always issues 4x64-bit read bursts to L3 on reads that miss in the L2 cache. This is the default. 1 The L2CC issues 8x64-bit read bursts to L3 on reads that miss in the L2 cache. |
| inst_pref_en | 29 | rw | 0x0 | Instruction prefetch enable: You can set the following options for this register bit: 0 Instruction prefetching disabled. This is the default. 1 Instruction prefetching enabled |
| data_pref_en | 28 | rw | 0x0 | Data prefetch enable: You can set the following options for this register bit: 0 Data prefetching disabled. This is the default. 1 Data prefetching enabled. |
| double_linefill_on_wrap_read_en | 27 | rw | 0x0 | Double linefill on WRAP read disable: You can set the following options for this register bit: 0 Double linefill on WRAP read enabled. This is the default. 1 Double linefill on WRAP read disabled |
| reserved | 26:25 | waz,raz | 0x0 | reserved |
| pref_drop_en | 24 | rw | 0x0 | Prefetch drop enable: You can set the following options for this register bit: 0 The L2CC does not discard prefetch reads issued to L3. This is the default. 1 The L2CC discards prefetch reads issued to L3 when there is a resource conflict with explicit reads. |
| incr_double_linefill_en | 23 | rw | 0x0 | Incr double Linefill enable: You can set the following options for this register bit: 0 The L2CC does not issue INCR 8x64-bit read bursts to L3 on reads that miss in the L2 cache. This is the default. 1 The L2CC can issue INCR 8x64-bit read bursts to L3 on reads that miss in the L2 cache. |
| reserved | 22 | waz,raz | 0x0 | reserved |

| Field Name | Bits | Type | Reset Value | Description |
|--------------------------------|------|---------|-------------|--|
| not_same_id_on_excl_s eq_en | 21 | rw | 0x0 | Not same ID on exclusive sequence enable: You can set the following options for this register bit: 0 Read and write portions of a non-cacheable exclusive sequence have the same AXI ID when issued to L3. This is the default. 1 Read and write portions of a non-cacheable exclusive sequence do not have the same AXI ID when issued to L3. |
| reserved | 20:5 | waz,raz | 0x0 | reserved |
| prefetch_offset | 4:0 | rw | 0x0 | Default = b00000. |

Register ([L2Cpl310](#)) reg15_power_ctrl

| | |
|------------------|---|
| Name | reg15_power_ctrl |
| Relative Address | 0x00000F80 |
| Absolute Address | 0xF8F02F80 |
| Width | 32 bits |
| Access Type | mixed |
| Reset Value | 0x00000000 |
| Description | Purpose Controls the operating mode clock and power modes. Usage constraints There are no usage constraints. |

Register reg15_power_ctrl Details

| Field Name | Bits | Type | Reset Value | Description |
|-----------------------|------|---------|-------------|--|
| reserved | 31:2 | waz,raz | 0x0 | reserved |
| dynamic_clk_gating_en | 1 | rw | 0x0 | Dynamic clock gating enable. 1 = Enabled. 0 = Masked. This is the default. |
| standby_mode_en | 0 | rw | 0x0 | Standby mode enable. 1 = Enabled. 0 = Masked. This is the default |

B.24 Application Processing Unit (mpcore)

| | |
|---------------|---|
| Module Name | Application Processing Unit (mpcore) |
| Software Name | XSCU |
| Base Address | 0xF8F00000 mpcore |
| Description | Mpcore - SCU, Interrupt controller, Counters and Timers |
| Vendor Info | Arm |

Register Summary

| Register Name | Address | Width | Type | Reset Value | Description |
|--|------------|-------|------|-------------|---|
| SCU_CONTROL_REGISTER | 0x00000000 | 32 | rw | 0x00000002 | SCU Control Register |
| SCU_CONFIGURATION_REGISTER | 0x00000004 | 32 | ro | 0x00000501 | SCU Configuration Register |
| SCU_CPU_Power_Status_Register | 0x00000008 | 32 | rw | 0x00000000 | SCU CPU Power Status Register |
| SCU_Invalidate_All_Registers_in_Secure_State | 0x0000000C | 32 | wo | 0x00000000 | SCU Invalidate All Registers in Secure State |
| Filtering_Start_Address_Register | 0x00000040 | 32 | rw | 0x00100000 | Filtering Start Address Register |
| Filtering_End_Address_Register | 0x00000044 | 32 | rw | 0x00000000 | Defined by FILTEREND input |
| SCU_Access_Control_Register_SAC | 0x00000050 | 32 | rw | 0x0000000F | SCU Access Control (SAC) Register |
| SCU_Non_secure_Access_Control_Register_SNSAC | 0x00000054 | 32 | ro | 0x00000000 | SCU Non-secure Access Control Register SNSAC |
| ICCICR | 0x00000100 | 32 | rw | 0x00000000 | CPU Interface Control Register |
| ICCPMR | 0x00000104 | 32 | rw | 0x00000000 | Interrupt Priority Mask Register |
| ICCBPR | 0x00000108 | 32 | rw | 0x00000002 | Binary Point Register |
| ICCIAR | 0x0000010C | 32 | rw | 0x000003FF | Interrupt Acknowledge Register |
| ICCEOIR | 0x00000110 | 32 | rw | 0x00000000 | End Of Interrupt Register |
| ICCRPR | 0x00000114 | 32 | rw | 0x000000FF | Running Priority Register |
| ICCHPIR | 0x00000118 | 32 | rw | 0x000003FF | Highest Pending Interrupt Register |
| ICCABPR | 0x0000011C | 32 | rw | 0x00000003 | Aliased Non-secure Binary Point Register |
| ICCIDR | 0x000001FC | 32 | ro | 0x3901243B | CPU Interface Implementer Identification Register |

| Register Name | Address | Width | Type | Reset Value | Description |
|---|------------|-------|------|-------------|---|
| Global_Timer_Counter_Register0 | 0x00000200 | 32 | rw | 0x00000000 | Global Timer Counter Register 0 |
| Global_Timer_Counter_Register1 | 0x00000204 | 32 | rw | 0x00000000 | Global Timer Counter Register 1 |
| Global_Timer_Control_Register | 0x00000208 | 32 | rw | 0x00000000 | Global Timer Control Register |
| Global_Timer_Interrupt_Status_Register | 0x0000020C | 32 | rw | 0x00000000 | Global Timer Interrupt Status Register |
| Comparator_Value_Register0 | 0x00000210 | 32 | rw | 0x00000000 | Comparator Value Register_0 |
| Comparator_Value_Register1 | 0x00000214 | 32 | rw | 0x00000000 | Comparator Value Register_1 |
| Auto_increment_Register | 0x00000218 | 32 | rw | 0x00000000 | Auto-increment Register |
| Private_Timer_Load_Register | 0x00000600 | 32 | rw | 0x00000000 | Private Timer Load Register |
| Private_Timer_Counter_Register | 0x00000604 | 32 | rw | 0x00000000 | Private Timer Counter Register |
| Private_Timer_Control_Register | 0x00000608 | 32 | rw | 0x00000000 | Private Timer Control Register |
| Private_Timer_Interrupt_Status_Register | 0x0000060C | 32 | rw | 0x00000000 | Private Timer Interrupt Status Register |
| Watchdog_Load_Register | 0x00000620 | 32 | rw | 0x00000000 | Watchdog Load Register |
| Watchdog_Counter_Register | 0x00000624 | 32 | rw | 0x00000000 | Watchdog Counter Register |
| Watchdog_Control_Register | 0x00000628 | 32 | rw | 0x00000000 | Watchdog Control Register |
| Watchdog_Interrupt_Status_Register | 0x0000062C | 32 | rw | 0x00000000 | Watchdog Interrupt Status Register |
| Watchdog_Reset_Status_Register | 0x00000630 | 32 | rw | 0x00000000 | Watchdog Reset Status Register |
| Watchdog_Disable_Register | 0x00000634 | 32 | rw | 0x00000000 | Watchdog Disable Register |
| ICDDCR | 0x00001000 | 32 | rw | 0x00000000 | Distributor Control Register |
| ICDICTR | 0x00001004 | 32 | ro | 0x0000FC22 | Interrupt Controller Type Register |
| ICDIIDR | 0x00001008 | 32 | ro | 0x0102043B | Distributor Implementer Identification Register |
| ICDISR0 | 0x00001080 | 32 | rw | 0x00000000 | Interrupt Security Register_0 |
| ICDISR1 | 0x00001084 | 32 | rw | 0x00000000 | Interrupt Security Register_1 |
| ICDISR2 | 0x00001088 | 32 | rw | 0x00000000 | Interrupt Security Register_2 |
| ICDISER0 | 0x00001100 | 32 | rw | 0x0000FFFF | Interrupt Set-enable Register 0 |

| Register Name | Address | Width | Type | Reset Value | Description |
|--------------------------|------------|-------|------|-------------|------------------------------------|
| ICDISER1 | 0x00001104 | 32 | rw | 0x00000000 | Interrupt Set-enable Register 1 |
| ICDISER2 | 0x00001108 | 32 | rw | 0x00000000 | Interrupt Set-enable Register 2 |
| ICDICER0 | 0x00001180 | 32 | rw | 0x0000FFFF | Interrupt Clear-Enable Register 0 |
| ICDICER1 | 0x00001184 | 32 | rw | 0x00000000 | Interrupt Clear-Enable Register 1 |
| ICDICER2 | 0x00001188 | 32 | rw | 0x00000000 | Interrupt Clear-Enable Register 2 |
| ICDISPR0 | 0x00001200 | 32 | rw | 0x00000000 | Interrupt Set-pending Register_0 |
| ICDISPR1 | 0x00001204 | 32 | rw | 0x00000000 | Interrupt Set-pending Register_1 |
| ICDISPR2 | 0x00001208 | 32 | rw | 0x00000000 | Interrupt Set-pending Register_2 |
| ICDICPR0 | 0x00001280 | 32 | rw | 0x00000000 | Interrupt Clear-Pending Register_0 |
| ICDICPR1 | 0x00001284 | 32 | rw | 0x00000000 | Interrupt Clear-Pending Register_1 |
| ICDICPR2 | 0x00001288 | 32 | rw | 0x00000000 | Interrupt Clear-Pending Register_2 |
| ICDABR0 | 0x00001300 | 32 | rw | 0x00000000 | Active Bit register_0 |
| ICDABR1 | 0x00001304 | 32 | rw | 0x00000000 | Active Bit register_1 |
| ICDABR2 | 0x00001308 | 32 | rw | 0x00000000 | Active Bit register_2 |
| ICDIPR0 | 0x00001400 | 32 | rw | 0x00000000 | Interrupt Priority Register_0 |
| ICDIPR1 | 0x00001404 | 32 | rw | 0x00000000 | Interrupt Priority Register_1 |
| ICDIPR2 | 0x00001408 | 32 | rw | 0x00000000 | Interrupt Priority Register_2 |
| ICDIPR3 | 0x0000140C | 32 | rw | 0x00000000 | Interrupt Priority Register_3 |
| ICDIPR4 | 0x00001410 | 32 | rw | 0x00000000 | Interrupt Priority Register_4 |
| ICDIPR5 | 0x00001414 | 32 | rw | 0x00000000 | Interrupt Priority Register_5 |
| ICDIPR6 | 0x00001418 | 32 | rw | 0x00000000 | Interrupt Priority Register_6 |
| ICDIPR7 | 0x0000141C | 32 | rw | 0x00000000 | Interrupt Priority Register_7 |
| ICDIPR8 | 0x00001420 | 32 | rw | 0x00000000 | Interrupt Priority Register_8 |
| ICDIPR9 | 0x00001424 | 32 | rw | 0x00000000 | Interrupt Priority Register_9 |
| ICDIPR10 | 0x00001428 | 32 | rw | 0x00000000 | Interrupt Priority Register_10 |
| ICDIPR11 | 0x0000142C | 32 | rw | 0x00000000 | Interrupt Priority Register_11 |
| ICDIPR12 | 0x00001430 | 32 | rw | 0x00000000 | Interrupt Priority Register_12 |
| ICDIPR13 | 0x00001434 | 32 | rw | 0x00000000 | Interrupt Priority Register_13 |
| ICDIPR14 | 0x00001438 | 32 | rw | 0x00000000 | Interrupt Priority Register_14 |
| ICDIPR15 | 0x0000143C | 32 | rw | 0x00000000 | Interrupt Priority Register_15 |
| ICDIPR16 | 0x00001440 | 32 | rw | 0x00000000 | Interrupt Priority Register_16 |

| Register Name | Address | Width | Type | Reset Value | Description |
|---------------------------|------------|-------|------|-------------|---|
| ICDIPR17 | 0x00001444 | 32 | rw | 0x00000000 | Interrupt Priority Register_17 |
| ICDIPR18 | 0x00001448 | 32 | rw | 0x00000000 | Interrupt Priority Register_18 |
| ICDIPR19 | 0x0000144C | 32 | rw | 0x00000000 | Interrupt Priority Register_19 |
| ICDIPR20 | 0x00001450 | 32 | rw | 0x00000000 | Interrupt Priority Register_20 |
| ICDIPR21 | 0x00001454 | 32 | rw | 0x00000000 | Interrupt Priority Register_21 |
| ICDIPR22 | 0x00001458 | 32 | rw | 0x00000000 | Interrupt Priority Register_22 |
| ICDIPR23 | 0x0000145C | 32 | rw | 0x00000000 | Interrupt Priority Register_23 |
| ICDIPTRO | 0x00001800 | 32 | ro | 0x01010101 | Interrupt Processor Targets Register 0 |
| ICDIPTR1 | 0x00001804 | 32 | ro | 0x01010101 | Interrupt Processor Targets Register 1 |
| ICDIPTR2 | 0x00001808 | 32 | ro | 0x01010101 | Interrupt Processor Targets Register 2 |
| ICDIPTR3 | 0x0000180C | 32 | ro | 0x01010101 | Interrupt Processor Targets Register 3 |
| ICDIPTR4 | 0x00001810 | 32 | rw | 0x00000000 | Interrupt Processor Targets Register 4 |
| ICDIPTR5 | 0x00001814 | 32 | ro | 0x00000000 | Interrupt Processor Targets Register 5 |
| ICDIPTR6 | 0x00001818 | 32 | ro | 0x01000000 | Interrupt Processor Targets Register 6 |
| ICDIPTR7 | 0x0000181C | 32 | ro | 0x01010101 | Interrupt Processor Targets Register 7 |
| ICDIPTR8 | 0x00001820 | 32 | rw | 0x00000000 | Interrupt Processor Targets Register 8 |
| ICDIPTR9 | 0x00001824 | 32 | rw | 0x00000000 | Interrupt Processor Targets Register 9 |
| ICDIPTR10 | 0x00001828 | 32 | rw | 0x00000000 | Interrupt Processor Targets Register 10 |
| ICDIPTR11 | 0x0000182C | 32 | rw | 0x00000000 | Interrupt Processor Targets Register 11 |
| ICDIPTR12 | 0x00001830 | 32 | rw | 0x00000000 | Interrupt Processor Targets Register 12 |
| ICDIPTR13 | 0x00001834 | 32 | rw | 0x00000000 | Interrupt Processor Targets Register 13 |
| ICDIPTR14 | 0x00001838 | 32 | rw | 0x00000000 | Interrupt Processor Targets Register 14 |
| ICDIPTR15 | 0x0000183C | 32 | rw | 0x00000000 | Interrupt Processor Targets Register 15 |
| ICDIPTR16 | 0x00001840 | 32 | rw | 0x00000000 | Interrupt Processor Targets Register 16 |
| ICDIPTR17 | 0x00001844 | 32 | rw | 0x00000000 | Interrupt Processor Targets Register 17 |

| Register Name | Address | Width | Type | Reset Value | Description |
|------------------------------|------------|-------|------|-------------|---|
| ICDIPTR18 | 0x00001848 | 32 | rw | 0x00000000 | Interrupt Processor Targets Register 18 |
| ICDIPTR19 | 0x0000184C | 32 | rw | 0x00000000 | Interrupt Processor Targets Register 19 |
| ICDIPTR20 | 0x00001850 | 32 | rw | 0x00000000 | Interrupt Processor Targets Register 20 |
| ICDIPTR21 | 0x00001854 | 32 | rw | 0x00000000 | Interrupt Processor Targets Register 21 |
| ICDIPTR22 | 0x00001858 | 32 | rw | 0x00000000 | Interrupt Processor Targets Register 22 |
| ICDIPTR23 | 0x0000185C | 32 | rw | 0x00000000 | Interrupt Processor Targets Register 23 |
| ICDICFR0 | 0x00001C00 | 32 | ro | 0xAAAAAAAA | Interrupt Configuration Register 0 |
| ICDICFR1 | 0x00001C04 | 32 | rw | 0x7DC00000 | Interrupt Configuration Register 1 |
| ICDICFR2 | 0x00001C08 | 32 | rw | 0x55555555 | Interrupt Configuration Register 2 |
| ICDICFR3 | 0x00001C0C | 32 | rw | 0x55555555 | Interrupt Configuration Register 3 |
| ICDICFR4 | 0x00001C10 | 32 | rw | 0x55555555 | Interrupt Configuration Register 4 |
| ICDICFR5 | 0x00001C14 | 32 | rw | 0x55555555 | Interrupt Configuration Register 5 |
| ppi_status | 0x00001D00 | 32 | ro | 0x00000000 | PPI Status Register |
| spi_status_0 | 0x00001D04 | 32 | ro | 0x00000000 | SPI Status Register 0 |
| spi_status_1 | 0x00001D08 | 32 | ro | 0x00000000 | SPI Status Register 1 |
| ICDSGIR | 0x00001F00 | 32 | rw | 0x00000000 | Software Generated Interrupt Register |
| ICPIDR4 | 0x00001FD0 | 32 | rw | 0x00000004 | Peripheral ID4 |
| ICPIDR5 | 0x00001FD4 | 32 | rw | 0x00000000 | Peripheral ID5 |
| ICPIDR6 | 0x00001FD8 | 32 | rw | 0x00000000 | Peripheral ID6 |
| ICPIDR7 | 0x00001FDC | 32 | rw | 0x00000000 | Peripheral ID7 |
| ICPIDR0 | 0x00001FE0 | 32 | rw | 0x00000090 | Peripheral ID0 |
| ICPIDR1 | 0x00001FE4 | 32 | rw | 0x000000B3 | Peripheral ID1 |
| ICPIDR2 | 0x00001FE8 | 32 | rw | 0x0000001B | Peripheral ID2 |
| ICPIDR3 | 0x00001FEC | 32 | rw | 0x00000000 | Peripheral ID3 |
| ICCIDR0 | 0x00001FF0 | 32 | rw | 0x0000000D | Component ID0 |
| ICCIDR1 | 0x00001FF4 | 32 | rw | 0x000000F0 | Component ID1 |
| ICCIDR2 | 0x00001FF8 | 32 | rw | 0x00000005 | Component ID2 |
| ICCIDR3 | 0x00001FFC | 32 | rw | 0x000000B1 | Component ID3 |

Register ([mpcore](#)) SCU_CONTROL_REGISTER

| | |
|------------------|----------------------|
| Name | SCU_CONTROL_REGISTER |
| Relative Address | 0x00000000 |
| Absolute Address | 0xF8F00000 |
| Width | 32 bits |
| Access Type | rw |
| Reset Value | 0x00000002 |
| Description | SCU Control Register |

Register SCU_CONTROL_REGISTER Details

| Field Name | Bits | Type | Reset Value | Description |
|----------------------------------|------|------|-------------|---|
| reserved | 31:7 | rw | 0x0 | Reserved. Writes are ignored, read data is always zero. |
| IC_standby_enable | 6 | rw | 0x0 | When set, this stops the Interrupt Controller clock when no interrupts are pending, and no CPU is performing a read/write request. |
| SCU_standby_enable | 5 | rw | 0x0 | When set, SCU CLK is turned off when all processors are in WFI mode, there is no pending request on the ACP (if implemented), and there is no remaining activity in the SCU. When SCU CLK is off, ARREADYs, AWREADYs and WREADYs on the ACP are forced LOW. The clock is turned on when any processor leaves WFI mode, or if there is a new request on the ACP. |
| Force_all_Device_to_port0_enable | 4 | rw | 0x0 | When set, all requests from the ACP or processors with AxCACHE = NonCacheable Bufferable are forced to be issued on the AXI Master port M0. |
| SCU_Speculative_linefills_enable | 3 | rw | 0x0 | When set, coherent linefill requests are sent speculatively to the L2C-310 in parallel with the tag look-up. If the tag look-up misses, the confirmed linefill is sent to the L2C-310 and gets RDATA earlier because the data request was already initiated by the speculative request. This feature works only if the L2C-310 is present in the design. |
| SCU_RAMs_Parity_enable | 2 | rw | 0x0 | 1 = Parity on. 0 = Parity off. This is the default setting. This bit is always zero if support for parity is not implemented. |

| Field Name | Bits | Type | Reset Value | Description |
|--------------------------|------|------|-------------|---|
| Address_filtering_enable | 1 | rw | 0x1 | 1 = Addressing filtering on. 0 = Addressing filtering off. The default value is the value of FILTEREN sampled when nSCURESET is deasserted. This bit is always zero if the SCU is implemented in the single master port configuration. |
| SCU_enable | 0 | rw | 0x0 | 1 = SCU enable. 0 = SCU disable. This is the default setting |

Register ([mpcore](#)) SCU_CONFIGURATION_REGISTER

| | |
|------------------|----------------------------|
| Name | SCU_CONFIGURATION_REGISTER |
| Relative Address | 0x00000004 |
| Absolute Address | 0xF8F00004 |
| Width | 32 bits |
| Access Type | ro |
| Reset Value | 0x00000501 |
| Description | SCU Configuration Register |

Register SCU_CONFIGURATION_REGISTER Details

| Field Name | Bits | Type | Reset Value | Description |
|---------------|-------|------|-------------|---|
| reserved | 31:16 | ro | 0x0 | Should Be Zero (SBZ) |
| Tag_RAM_sizes | 15:8 | ro | 0x5 | Bits [15:14] indicate Cortex-A9 processor CPU3 tag RAM size if present. Bits [13:12] indicate Cortex-A9 processor CPU2 tag RAM size if present. Bits [11:10] indicate Cortex-A9 processor CPU1 tag RAM size if present. Bits [9:8] indicate Cortex-A9 processor CPU0 tag RAM size. The encoding is as follows: b11 = reserved b10 = 64KB cache, 256 indexes per tag RAM b01 = 32KB cache, 128 indexes per tag RAM b00 = 16KB cache, 64 indexes per tag RAM. |

| Field Name | Bits | Type | Reset Value | Description |
|------------|------|------|-------------|--|
| CPUs_SMP | 7:4 | ro | 0x0 | Shows the Cortex-A9 processors that are in Symmetric Multi-processing (SMP) or Asymmetric Multi-processing (AMP) mode. 0 = this Cortex-A9 processor is in AMP mode not taking part in coherency or not present. 1 = this Cortex-A9 processor is in SMP mode taking part in coherency. Bit 7 is for CPU3 Bit 6 is for CPU2 Bit 5 is for CPU1 Bit 4 is for CPU0. |
| reserved | 3:2 | ro | 0x0 | Should Be Zero (SBZ) |
| CPU_number | 1:0 | ro | 0x1 | Number of CPUs present in the Cortex-A9 MPCore processor b11 = four Cortex-A9 processors, CPU0, CPU1, CPU2, and CPU3 b10 = three Cortex-A9 processors, CPU0, CPU1, and CPU2 b01 = two Cortex-A9 processors, CPU0 and CPU1 b00 = one Cortex-A9 processor, CPU0. |

Register ([mpcore](#)) SCU_CPU_Power_Status_Register

| | |
|------------------|-------------------------------|
| Name | SCU_CPU_Power_Status_Register |
| Relative Address | 0x00000008 |
| Absolute Address | 0xF8F00008 |
| Width | 32 bits |
| Access Type | rw |
| Reset Value | 0x00000000 |
| Description | SCU CPU Power Status Register |

Register SCU_CPU_Power_Status_Register Details

| Field Name | Bits | Type | Reset Value | Description |
|-------------|-------|------|-------------|---|
| reserved | 31:26 | rw | 0x0 | Should Be Zero (SBZ) |
| CPU3_status | 25:24 | rw | 0x0 | Power status of the Cortex-A9 processor: b00: Normal mode. b01: Reserved. b10: the Cortex-A9 processor is about to enter (or is in) dormant mode. No coherency request is sent to the Cortex-A9 processor. b11: the Cortex-A9 processor is about to enter (or is in) powered-off mode, or is nonpresent. No coherency request is sent to the Cortex-A9 processor. |
| reserved | 23:18 | rw | 0x0 | Should Be Zero (SBZ) |
| CPU2_status | 17:16 | rw | 0x0 | Power status of the Cortex-A9 processor |
| reserved | 15:10 | rw | 0x0 | Should Be Zero (SBZ) |
| CPU1_status | 9:8 | rw | 0x0 | Power status of the Cortex-A9 processor |
| reserved | 7:2 | rw | 0x0 | Should Be Zero (SBZ) |
| CPU0_status | 1:0 | rw | 0x0 | Power status of the Cortex-A9 processor |

Register ([mpcore](#)) SCU_Invalidate_All_Registers_in_Secure_State

| | |
|------------------|--|
| Name | SCU_Invalidate_All_Registers_in_Secure_State |
| Relative Address | 0x0000000C |
| Absolute Address | 0xF8F0000C |
| Width | 32 bits |
| Access Type | wo |
| Reset Value | 0x00000000 |
| Description | SCU Invalidate All Registers in Secure State |

Register SCU_Invalidate_All_Registers_in_Secure_State Details

| Field Name | Bits | Type | Reset Value | Description |
|------------|-------|------|-------------|---|
| NA | 31:16 | wo | 0x0 | NA |
| CPU3_ways | 15:12 | wo | 0x0 | Specifies the ways that must be invalidated for CPU3. Writing to these bits has no effect if the Cortex-A9 MPCore processor has fewer than four processors. |

| Field Name | Bits | Type | Reset Value | Description |
|------------|------|------|-------------|---|
| CPU2_ways | 11:8 | wo | 0x0 | Specifies the ways that must be invalidated for CPU2. Writing to these bits has no effect if the Cortex-A9 MPCore processor has fewer than three processors |
| CPU1_ways | 7:4 | wo | 0x0 | Specifies the ways that must be invalidated for CPU1. Writing to these bits has no effect if the Cortex-A9 MPCore processor has fewer than two processors. |
| CPU0_ways | 3:0 | wo | 0x0 | Specifies the ways that must be invalidated for CPU0 |

Register ([mpcore](#)) Filtering_Start_Address_Register

| | |
|------------------|----------------------------------|
| Name | Filtering_Start_Address_Register |
| Relative Address | 0x00000040 |
| Absolute Address | 0xF8F00040 |
| Width | 32 bits |
| Access Type | rw |
| Reset Value | 0x00100000 |
| Description | Filtering Start Address Register |

Register Filtering_Start_Address_Register Details

| Field Name | Bits | Type | Reset Value | Description |
|-------------------------|-------|------|-------------|---|
| Filtering_start_address | 31:20 | rw | 0x1 | Start address for use with master port 1 in a two-master port configuration when address filtering is enabled. The default value is the value of FILTERSTART sampled on exit from reset. The value on the pin gives the upper address bits with 1MB granularity. |
| SBZ | 19:0 | rw | 0x0 | SBZ |

Register ([mpcore](#)) Filtering_End_Address_Register

| | |
|------------------|--------------------------------|
| Name | Filtering_End_Address_Register |
| Relative Address | 0x00000044 |
| Absolute Address | 0xF8F00044 |
| Width | 32 bits |
| Access Type | rw |
| Reset Value | 0x00000000 |

Description Defined by FILTEREND input

Register Filtering_End_Address_Register Details

| Field Name | Bits | Type | Reset Value | Description |
|-----------------------|-------|------|-------------|--|
| Filtering_end_address | 31:20 | rw | 0x0 | End address for use with master port 1 in a two-master port configuration, when address filtering is enabled. The default value is the value of FILTEREND sampled on exit from reset. The value on the pin gives the upper address bits with 1MB granularity. |
| SBZ | 19:0 | rw | 0x0 | SBZ |

Register ([mpcore](#)) SCU_Access_Control_Register_SAC

Name SCU_Access_Control_Register_SAC
 Relative Address 0x00000050
 Absolute Address 0xF8F00050
 Width 32 bits
 Access Type rw
 Reset Value 0x0000000F
 Description SCU Access Control (SAC) Register

Register SCU_Access_Control_Register_SAC Details

| Field Name | Bits | Type | Reset Value | Description |
|------------|------|------|-------------|--|
| | 31:4 | rw | 0x0 | SBZ |
| CPU3 | 3 | rw | 0x1 | 0 = CPU3 cannot access the components. 1 = CPU3 can access the components. This is the default. |
| CPU2 | 2 | rw | 0x1 | 0 = CPU2 cannot access the components. 1 = CPU2 can access the components. This is the default. |
| CPU1 | 1 | rw | 0x1 | 0 = CPU1 cannot access the components. 1 = CPU1 can access the components. This is the default. |
| CPU0 | 0 | rw | 0x1 | 0 = CPU0 cannot access the components. 1 = CPU0 can access the components. This is the default. |

Register ([mpcore](#)) SCU_Non_secure_Access_Control_Register

| | |
|------------------|---|
| Name | SCU_Non_secure_Access_Control_Register |
| Relative Address | 0x00000054 |
| Absolute Address | 0xF8F00054 |
| Width | 32 bits |
| Access Type | ro |
| Reset Value | 0x00000000 |
| Description | SCU Non-secure Access Control Register SNSAC |

Register SCU_Non_secure_Access_Control_Register Details

| Field Name | Bits | Type | Reset Value | Description |
|-------------------------------|-------|------|-------------|---|
| SBZ | 31:12 | ro | 0x0 | SBZ |
| CPU3_global_timer | 11 | ro | 0x0 | same as above |
| CPU2_global_timer | 10 | ro | 0x0 | same as above |
| CPU1_global_timer | 9 | ro | 0x0 | same as above |
| CPU0_global_timer | 8 | ro | 0x0 | Non-secure access to the global timer for CPU<n>. * <n> is 3 for bit[11] * <n> is 2 for bit[10] * <n> is 1 for bit[9] * <n> is 0 for bit[8]. 0 = Secure accesses only. This is the default value. 1 = Secure accesses and Non-Secure accesses. |
| Private_timers_for_CPU 3 | 7 | ro | 0x0 | same as above |
| Private_timers_for_CPU 2 | 6 | ro | 0x0 | same as above |
| Private_timers_for_CPU 1 | 5 | ro | 0x0 | same as above |
| Private_timers_for_CPU 0 | 4 | ro | 0x0 | Non-secure access to the private timer and watchdog for CPU<n>. * <n> is 3 for bit[7] * <n> is 2 for bit[6] * <n> is 1 for bit[5] * <n> is 0 for bit[4]. 0 = Secure accesses only. Non-secure reads return 0. This is the default value. 1 = Secure accesses and Non-secure accesses. |
| Component_access_for _CPU3 | 3 | ro | 0x0 | same as above |

| Field Name | Bits | Type | Reset Value | Description |
|---------------------------|------|------|-------------|---|
| Component_access_for_CPU2 | 2 | ro | 0x0 | same as above |
| Component_access_for_CPU1 | 1 | ro | 0x0 | same as above |
| Component_access_for_CPU0 | 0 | ro | 0x0 | Non-secure access to the components for CPU<n>. * <n> is 3 for bit[3] * <n> is 2 for bit[2] * <n> is 1 for bit[1] * <n> is 0 for bit[0]. 0 = CPU cannot write the components 1 = CPU can access the components. |

Register ([mpcore](#)) ICCICR

| | |
|------------------|--------------------------------|
| Name | ICCICR |
| Relative Address | 0x00000100 |
| Absolute Address | 0xF8F00100 |
| Width | 32 bits |
| Access Type | rw |
| Reset Value | 0x00000000 |
| Description | CPU Interface Control Register |

Register ICCICR Details

| Field Name | Bits | Type | Reset Value | Description |
|------------|------|------|-------------|--|
| reserved | 31:5 | rw | 0x0 | reserved |
| SBPR | 4 | rw | 0x0 | Controls whether the CPU interface uses the Secure or Non-secure Binary Point Register for preemption. 0: use the Secure Binary Point Register for Secure interrupts, and use the Non-secure Binary Point Register for Non-secure interrupts. 1: use the Secure Binary Point Register for both Secure and Non-secure interrupts. |
| FIQEn | 3 | rw | 0x0 | Controls whether the GIC signals Secure interrupts to a target processor using the FIQ or the IRQ signal. 0: using IRQ, 1: using FIQ. The GIC always signals Non-secure interrupts using IRQ. |

| Field Name | Bits | Type | Reset Value | Description |
|------------|------|------|-------------|---|
| AckCtl | 2 | rw | 0x0 | Controls whether a Secure read of the ICCIAR, when the highest priority pending interrupt is Non-secure, causes the CPU interface to acknowledge the interrupt. |
| EnableNS | 1 | rw | 0x0 | An alias of the Enable bit in the Non-secure ICCICR. This alias bit means Secure software can enable the signal of Non-secure interrupts. |
| EnableS | 0 | rw | 0x0 | Global enable for the signaling of Secure interrupts by the CPU interfaces to the connected processors. |

Register ([mpcore](#)) ICCPMR

| | |
|------------------|----------------------------------|
| Name | ICCPMR |
| Relative Address | 0x00000104 |
| Absolute Address | 0xF8F00104 |
| Width | 32 bits |
| Access Type | rw |
| Reset Value | 0x00000000 |
| Description | Interrupt Priority Mask Register |

Register ICCPMR Details

| Field Name | Bits | Type | Reset Value | Description |
|------------|------|------|-------------|--|
| reserved | 31:8 | rw | 0x0 | reserved |
| Priority | 7:0 | rw | 0x0 | The priority mask level for the CPU interface. If the priority of an interrupt is higher than the value indicated by this field, the interface signals the interrupt to the processor. |

Register ([mpcore](#)) ICCBPR

| | |
|------------------|-----------------------|
| Name | ICCBPR |
| Relative Address | 0x00000108 |
| Absolute Address | 0xF8F00108 |
| Width | 32 bits |
| Access Type | rw |
| Reset Value | 0x00000002 |
| Description | Binary Point Register |

Register ICCBPR Details

| Field Name | Bits | Type | Reset Value | Description |
|--------------|------|------|-------------|--|
| reserved | 31:3 | rw | 0x0 | reserved |
| Binary_point | 2:0 | rw | 0x2 | The value of this field controls the 8-bit interrupt priority field is split into a group priority field, used to determine interrupt preemption, and a subpriority field. |

Register ([mpcore](#)) ICCIAR

| | |
|------------------|--------------------------------|
| Name | ICCIAR |
| Relative Address | 0x0000010C |
| Absolute Address | 0xF8F0010C |
| Width | 32 bits |
| Access Type | rw |
| Reset Value | 0x000003FF |
| Description | Interrupt Acknowledge Register |

Register ICCIAR Details

| Field Name | Bits | Type | Reset Value | Description |
|------------|-------|------|-------------|--|
| reserved | 31:13 | rw | 0x0 | reserved |
| CPUID | 12:10 | rw | 0x0 | Identifies the processor that requested the interrupt. Returns the number of the CPU interface that made the request. |
| ACKINTID | 9:0 | rw | 0x3FF | The interrupt ID. This read acts as an acknowledge for the interrupt. |

Register ([mpcore](#)) ICCEOIR

| | |
|------------------|---------------------------|
| Name | ICCEOIR |
| Relative Address | 0x00000110 |
| Absolute Address | 0xF8F00110 |
| Width | 32 bits |
| Access Type | rw |
| Reset Value | 0x00000000 |
| Description | End Of Interrupt Register |

Register ICCEOIR Details

| Field Name | Bits | Type | Reset Value | Description |
|------------|-------|------|-------------|--|
| reserved | 31:13 | rw | 0x0 | reserved |
| CPUID | 12:10 | rw | 0x0 | On completion of the processing of an SGI, this field contains the CPUID value from the corresponding ICCIAR access. |
| EOIINTID | 9:0 | rw | 0x0 | The ACKINTID value from the corresponding ICCIAR access. |

Register ([mpcore](#)) ICCRPR

| | |
|------------------|---------------------------|
| Name | ICCRPR |
| Relative Address | 0x00000114 |
| Absolute Address | 0xF8F00114 |
| Width | 32 bits |
| Access Type | rw |
| Reset Value | 0x000000FF |
| Description | Running Priority Register |

Register ICCRPR Details

| Field Name | Bits | Type | Reset Value | Description |
|------------|------|------|-------------|---|
| reserved | 31:8 | rw | 0x0 | reserved |
| Priority | 7:0 | rw | 0xFF | The priority value of the highest priority interrupt that is active on the CPU interface. |

Register ([mpcore](#)) ICCHPIR

| | |
|------------------|------------------------------------|
| Name | ICCHPIR |
| Relative Address | 0x00000118 |
| Absolute Address | 0xF8F00118 |
| Width | 32 bits |
| Access Type | rw |
| Reset Value | 0x000003FF |
| Description | Highest Pending Interrupt Register |

Register ICCHPIR Details

| Field Name | Bits | Type | Reset Value | Description |
|------------|-------|------|-------------|--|
| reserved | 31:13 | rw | 0x0 | reserved |
| CPUID | 12:10 | rw | 0x0 | If the PENDINTID field returns the ID of an SGI, this field contains the CPUID value for that interrupt. The identifies the processor that generated the interrupt. |
| PENDINTID | 9:0 | rw | 0x3FF | The interrupt ID of the highest priority pending interrupt. |

Register ([mpcore](#)) ICCABPR

| | |
|------------------|--|
| Name | ICCABPR |
| Relative Address | 0x0000011C |
| Absolute Address | 0xF8F0011C |
| Width | 32 bits |
| Access Type | rw |
| Reset Value | 0x00000003 |
| Description | Aliased Non-secure Binary Point Register |

Register ICCABPR Details

| Field Name | Bits | Type | Reset Value | Description |
|--------------|------|------|-------------|---|
| reserved | 31:3 | rw | 0x0 | reserved |
| Binary_point | 2:0 | rw | 0x3 | Provides an alias of the Non-secure ICCBPR. |

Register ([mpcore](#)) ICCIDR

| | |
|------------------|---|
| Name | ICCIDR |
| Relative Address | 0x000001FC |
| Absolute Address | 0xF8F001FC |
| Width | 32 bits |
| Access Type | ro |
| Reset Value | 0x3901243B |
| Description | CPU Interface Implementer Identification Register |

Register ICCIDR Details

| Field Name | Bits | Type | Reset Value | Description |
|----------------------|-------|------|-------------|--|
| Part_number | 31:20 | ro | 0x390 | Identifies the peripheral |
| Architecture_version | 19:16 | ro | 0x1 | Identifies the architecture version |
| Revision_number | 15:12 | ro | 0x2 | Returns the revision number of the Interrupt Controller. The implementer defines the format of this field. |
| Implementer | 11:0 | ro | 0x43B | Returns the JEP106 code of the company that implemented the Cortex-A9 processor interface RTL. It uses the following construct: [11:8] the JEP106 continuation code of the implementer [7] 0 [6:0] the JEP106 code [6:0] of the implementer |

Register ([mpcore](#)) Global_Timer_Counter_Register0

| | |
|------------------|---------------------------------|
| Name | Global_Timer_Counter_Register0 |
| Relative Address | 0x00000200 |
| Absolute Address | 0xF8F00200 |
| Width | 32 bits |
| Access Type | rw |
| Reset Value | 0x00000000 |
| Description | Global Timer Counter Register 0 |

Note: This register is the first in an array of 2 identical registers listed in the table below. The details provided in this section apply to the entire array.

| Name | Address |
|--------------------------------|------------|
| Global_Timer_Counter_Register0 | 0xf8f00200 |
| Global_Timer_Counter_Register1 | 0xf8f00204 |

Register Global_Timer_Counter_Register0 to Global_Timer_Counter_Register1 Details

| Field Name | Bits | Type | Reset Value | Description |
|------------|------|------|-------------|--|
| | 31:0 | rw | 0x0 | <p>There are two timer counter registers. They are the lower 32-bit timer counter at offset 0x00 and the upper 32-bit timer counter at offset 0x04.</p> <p>You must access these registers with 32-bit accesses. You cannot use STRD/LDRD.</p> <p>To modify the register proceed as follows:</p> <ol style="list-style-type: none"> 1. Clear the timer enable bit in the Global Timer Control Register 2. Write the lower 32-bit timer counter register 3. Write the upper 32-bit timer counter register 4. Set the timer enable bit. <p>To get the value from the Global Timer Counter register proceed as follows:</p> <ol style="list-style-type: none"> 1. Read the upper 32-bit timer counter register 2. Read the lower 32-bit timer counter register 3. Read the upper 32-bit timer counter register again. If the value is different to the 32-bit upper value read previously, go back to step 2. Otherwise the 64-bit timer counter value is correct. |

Register ([mpcore](#)) Global_Timer_Control_Register

| | |
|------------------|-------------------------------|
| Name | Global_Timer_Control_Register |
| Relative Address | 0x00000208 |
| Absolute Address | 0xF8F00208 |
| Width | 32 bits |
| Access Type | rw |
| Reset Value | 0x00000000 |
| Description | Global Timer Control Register |

Register Global_Timer_Control_Register Details

| Field Name | Bits | Type | Reset Value | Description |
|------------|-------|------|-------------|--|
| reserved | 31:16 | rw | 0x0 | Reserved |
| Prescaler | 15:8 | rw | 0x0 | <p>The prescaler modifies the clock period for the decrementing event for the Counter Register. The timer interval is calculated using the following equation:</p> $(PRESCALER_value+1)*(Load_value+1)*(CPU_3x2x PERIOD)$ |

| Field Name | Bits | Type | Reset Value | Description |
|--------------|------|------|-------------|---|
| reserved | 7:4 | rw | 0x0 | Reserved |
| | 3 | rw | 0x0 | This bit is banked per Cortex-A9 processor. 1'b0: single shot mode. When the counter reaches the comparator value, sets the event flag. It is the responsibility of software to update the comparator value to get further events. 1'b1: auto increment mode. Each time the counter reaches the comparator value, the comparator register is incremented with the auto-increment register, so that further events can be set periodically without any software updates. |
| IRQ_Enable | 2 | rw | 0x0 | This bit is banked per Cortex-A9 processor. If set, the interrupt ID 27 is set as pending in the Interrupt Distributor when the event flag is set in the Timer Status Register. |
| Comp_Enablea | 1 | rw | 0x0 | This bit is banked per Cortex-A9 processor. If set, it allows the comparison between the 64-bit Timer Counter and the related 64-bit Comparator Register. |
| Timer_Enable | 0 | rw | 0x0 | Timer enable 1'b0 = Timer is disabled and the counter does not increment. All registers can still be read and written 1'b1 = Timer is enabled and the counter increments normally |

Register ([mpcore](#)) Global_Timer_Interrupt_Status_Register

| | |
|------------------|--|
| Name | Global_Timer_Interrupt_Status_Register |
| Relative Address | 0x0000020C |
| Absolute Address | 0xF8F0020C |
| Width | 32 bits |
| Access Type | rw |
| Reset Value | 0x00000000 |
| Description | Global Timer Interrupt Status Register |

Register Global_Timer_Interrupt_Status_Register Details

| Field Name | Bits | Type | Reset Value | Description |
|------------|------|------|-------------|---|
| reserved | 31:1 | rw | 0x0 | UNK/SBZP |
| Event_flag | 0 | rw | 0x0 | This is a banked register for all Cortex-A9 processors present. The event flag is a sticky bit that is automatically set when the Counter Register reaches the Comparator Register value. If the timer interrupt is enabled, Interrupt ID 27 is set as pending in the Interrupt Distributor after the event flag is set. The event flag is cleared when written to 1. Figure 4-7 shows the Global Timer Interrupt Status Register bit assignment. |

Register ([mpcore](#)) Comparator_Value_Register0

| | |
|------------------|-----------------------------|
| Name | Comparator_Value_Register0 |
| Relative Address | 0x00000210 |
| Absolute Address | 0xF8F00210 |
| Width | 32 bits |
| Access Type | rw |
| Reset Value | 0x00000000 |
| Description | Comparator Value Register_0 |

Note: This register is the first in an array of 2 identical registers listed in the table below. The details provided in this section apply to the entire array.

| Name | Address |
|----------------------------|------------|
| Comparator_Value_Register0 | 0xf8f00210 |
| Comparator_Value_Register1 | 0xf8f00214 |

Register Comparator_Value_Register0 to Comparator_Value_Register1 Details

| Field Name | Bits | Type | Reset Value | Description |
|------------|------|------|-------------|--|
| | 31:0 | rw | 0x0 | <p>There are two 32-bit registers, the lower 32-bit comparator value register at offset 0x10 and the upper 32-bit comparator value register at offset 0x14.</p> <p>You must access these registers with 32-bit accesses. You cannot use STRD/LDRD. There is a Comparator Value Register for each Cortex-A9 processor.</p> <p>To ensure that updates to this register do not set the Interrupt Status Register proceed as follows:</p> <ol style="list-style-type: none"> 1. Clear the Comp Enable bit in the Timer Control Register. 2. Write the lower 32-bit Comparator Value Register. 3. Write the upper 32-bit Comparator Value Register. 4. Set the Comp Enable bit and, if necessary, the IRQ enable bit. |

Register ([mpcore](#)) Auto_increment_Register

| | |
|------------------|-------------------------|
| Name | Auto_increment_Register |
| Relative Address | 0x00000218 |
| Absolute Address | 0xF8F00218 |
| Width | 32 bits |
| Access Type | rw |
| Reset Value | 0x00000000 |
| Description | Auto-increment Register |

Register Auto_increment_Register Details

| Field Name | Bits | Type | Reset Value | Description |
|------------|------|------|-------------|--|
| | 31:0 | rw | 0x0 | Auto-increment Register This 32-bit register gives the increment value of the Comparator Register when the Auto-increment bit is set in the Timer Control Register. Each Cortex-A9 processor present has its own Auto-increment Register. If the comp enable and auto-increment bits are set when the global counter reaches the Comparator Register value, the comparator is incremented by the auto-increment value, so that a new event can be set periodically. The global timer is not affected and goes on incrementing |

Register ([mpcore](#)) Private_Timer_Load_Register

| | |
|------------------|-----------------------------|
| Name | Private_Timer_Load_Register |
| Relative Address | 0x00000600 |
| Absolute Address | 0xF8F00600 |
| Width | 32 bits |
| Access Type | rw |
| Reset Value | 0x00000000 |
| Description | Private Timer Load Register |

Register Private_Timer_Load_Register Details

| Field Name | Bits | Type | Reset Value | Description |
|------------|------|------|-------------|--|
| | 31:0 | rw | 0x0 | The Timer Load Register contains the value copied to the Timer Counter Register when it decrements down to zero with auto reload mode enabled. Writing to the Timer Load Register means that you also write to the Timer Counter Register. |

Register ([mpcore](#)) Private_Timer_Counter_Register

| | |
|------------------|--------------------------------|
| Name | Private_Timer_Counter_Register |
| Relative Address | 0x00000604 |
| Absolute Address | 0xF8F00604 |
| Width | 32 bits |
| Access Type | rw |

Reset Value 0x00000000
 Description Private Timer Counter Register

Register Private_Timer_Counter_Register Details

| Field Name | Bits | Type | Reset Value | Description |
|------------|------|------|-------------|---|
| | 31:0 | rw | 0x0 | <p>The Timer Counter Register is a decrementing counter.</p> <p>The Timer Counter Register decrements if the timer is enabled using the timer enable bit in the Timer Control Register. If a Cortex-A9 processor timer is in debug state, the counter only decrements when the Cortex-A9 processor returns to non debug state.</p> <p>When the Timer Counter Register reaches zero and auto reload mode is enabled, it reloads the value in the Timer Load Register and then decrements from that value. If auto reload mode is not enabled, the Timer Counter Register decrements down to zero and stops.</p> <p>When the Timer Counter Register reaches zero, the timer interrupt status event flag is set and the interrupt ID 29 is set as pending in the Interrupt Distributor, if interrupt generation is enabled in the Timer Control Register.</p> <p>Writing to the Timer Counter Register or Timer Load Register forces the Timer Counter Register to decrement from the newly written value.</p> |

Register ([mpcore](#)) Private_Timer_Control_Register

Name Private_Timer_Control_Register
 Relative Address 0x00000608
 Absolute Address 0xF8F00608
 Width 32 bits
 Access Type rw
 Reset Value 0x00000000
 Description Private Timer Control Register

Register Private_Timer_Control_Register Details

| Field Name | Bits | Type | Reset Value | Description |
|--------------|-------|------|-------------|---|
| SBZP | 31:16 | rw | 0x0 | UNK/SBZP. |
| Prescaler | 15:8 | rw | 0x0 | The prescaler modifies the clock period for the decrementing event for the Counter Register. See Calculating timer intervals on page 4-2 for the equation.\ |
| UNK_SBZP | 7:3 | rw | 0x0 | UNK/SBZP. |
| IRQ_Enable | 2 | rw | 0x0 | If set, the interrupt ID 29 is set as pending in the Interrupt Distributor when the event flag is set in the Timer Status Register. |
| Auto_reload | 1 | rw | 0x0 | 1'b0 = Single shot mode. Counter decrements down to zero, sets the event flag and stops. 1'b1 = Auto-reload mode. Each time the Counter Register reaches zero, it is reloaded with the value contained in the Timer Load Register. |
| Timer_Enable | 0 | rw | 0x0 | Timer enable 1'b0 = Timer is disabled and the counter does not decrement. All registers can still be read and written 1'b1 = Timer is enabled and the counter decrements normally |

Register ([mpcore](#)) Private_Timer_Interrupt_Status_Register

| | |
|------------------|---|
| Name | Private_Timer_Interrupt_Status_Register |
| Relative Address | 0x0000060C |
| Absolute Address | 0xF8F0060C |
| Width | 32 bits |
| Access Type | rw |
| Reset Value | 0x00000000 |
| Description | Private Timer Interrupt Status Register |

Register Private_Timer_Interrupt_Status_Register Details

| Field Name | Bits | Type | Reset Value | Description |
|------------|------|------|-------------|---|
| UNK_SBZP | 31:1 | rw | 0x0 | UNK/SBZP |
| | 0 | rw | 0x0 | This is a banked register for all Cortex-A9 processors present. The event flag is a sticky bit that is automatically set when the Counter Register reaches zero. If the timer interrupt is enabled, Interrupt ID 29 is set as pending in the Interrupt Distributor after the event flag is set. The event flag is cleared when written to 1. |

Register ([mpcore](#)) Watchdog_Load_Register

| | |
|------------------|------------------------|
| Name | Watchdog_Load_Register |
| Relative Address | 0x00000620 |
| Absolute Address | 0xF8F00620 |
| Width | 32 bits |
| Access Type | rw |
| Reset Value | 0x00000000 |
| Description | Watchdog Load Register |

Register Watchdog_Load_Register Details

| Field Name | Bits | Type | Reset Value | Description |
|------------|------|------|-------------|--|
| | 31:0 | rw | 0x0 | Watchdog Load Register The Watchdog Load Register contains the value copied to the Watchdog Counter Register when it decrements down to zero with auto reload mode enabled, in Timer mode. Writing to the Watchdog Load Register means that you also write to the Watchdog Counter Register |

Register ([mpcore](#)) Watchdog_Counter_Register

| | |
|------------------|---------------------------|
| Name | Watchdog_Counter_Register |
| Relative Address | 0x00000624 |
| Absolute Address | 0xF8F00624 |
| Width | 32 bits |
| Access Type | rw |
| Reset Value | 0x00000000 |

Description Watchdog Counter Register

Register Watchdog_Counter_Register Details

| Field Name | Bits | Type | Reset Value | Description |
|------------|------|------|-------------|--|
| | 31:0 | rw | 0x0 | <p>Watchdog Counter Register</p> <p>The Watchdog Counter Register is a down counter.</p> <p>It decrements if the Watchdog is enabled using the Watchdog enable bit in the Watchdog Control Register. If the Cortex-A9 processor associated with the Watchdog is in debug state, the counter does not decrement until the Cortex-A9 processor returns to non debug state.</p> <p>When the Watchdog Counter Register reaches zero and auto reload mode is enabled, and in timer mode, it reloads the value in the Watchdog Load Register and then decrements from that value. If auto reload mode is not enabled or the watchdog is not in timer mode, the Watchdog Counter Register decrements down to zero and stops.</p> <p>When in watchdog mode the only way to update the Watchdog Counter Register is to write to the Watchdog Load Register. When in timer mode the Watchdog Counter Register is write accessible.</p> <p>The behavior of the watchdog when the Watchdog Counter Register reaches zero depends on its current mode:</p> <p>Timer mode When the Watchdog Counter Register reaches zero, the watchdog interrupt status event flag is set and the interrupt ID 30 is set as pending in the Interrupt Distributor, if interrupt generation is enabled in the Watchdog Control Register.</p> <p>Watchdog mode</p> <p>If a software failure prevents the Watchdog Counter Register from being refreshed, the Watchdog Counter Register reaches zero, the Watchdog reset status flag is set and the associated WDRESETREQ reset request output pin is asserted. The external reset source is then responsible for resetting all or part of the Cortex-A9 MPCore design.</p> |

Register ([mpcore](#)) Watchdog_Control_Register

| | |
|------------------|---------------------------|
| Name | Watchdog_Control_Register |
| Relative Address | 0x00000628 |
| Absolute Address | 0xF8F00628 |
| Width | 32 bits |
| Access Type | rw |
| Reset Value | 0x00000000 |
| Description | Watchdog Control Register |

Register Watchdog_Control_Register Details

| Field Name | Bits | Type | Reset Value | Description |
|-----------------|-------|------|-------------|---|
| reserved | 31:16 | rw | 0x0 | Reserved. |
| Prescaler | 15:8 | rw | 0x0 | The prescaler modifies the clock period for the decrementing event for the Counter Register. |
| | 7:4 | rw | 0x0 | Reserved. |
| Watchdog_mode | 3 | rw | 0x0 | 0: Timer mode, default Writing a zero to this bit has no effect. You must use the Watchdog Disable Register to put the watchdog into timer mode. See Watchdog Disable Register. 1: Watchdog mode. |
| IT_Enable | 2 | rw | 0x0 | If set, the interrupt ID 30 is set as pending in the Interrupt Distributor when the event flag is set in the watchdog Status Register. In watchdog mode this bit is ignored |
| Auto_reload | 1 | rw | 0x0 | 1'b0 = Single shot mode. Counter decrements down to zero, sets the event flag and stops. 1'b1 = Auto-reload mode. Each time the Counter Register reaches zero, it is reloaded with the value contained in the Load Register and then continues decrementing. |
| Watchdog_Enable | 0 | rw | 0x0 | Global watchdog enable 1'b0 = Watchdog is disabled and the counter does not decrement. All registers can still be read and /or written 1'b1 = Watchdog is enabled and the counter decrements normally. |

Register ([mpcore](#)) Watchdog_Interrupt_Status_Register

| | |
|------------------|------------------------------------|
| Name | Watchdog_Interrupt_Status_Register |
| Relative Address | 0x0000062C |
| Absolute Address | 0xF8F0062C |
| Width | 32 bits |
| Access Type | rw |
| Reset Value | 0x00000000 |
| Description | Watchdog Interrupt Status Register |

Register Watchdog_Interrupt_Status_Register Details

| Field Name | Bits | Type | Reset Value | Description |
|------------|------|------|-------------|--|
| reserved | 31:1 | rw | 0x0 | Reserved |
| Event_flag | 0 | rw | 0x0 | The event flag is a sticky bit that is automatically set when the Counter Register reaches zero in timer mode. If the watchdog interrupt is enabled, Interrupt ID 30 is set as pending in the Interrupt Distributor after the event flag is set. The event flag is cleared when written with a value of 1. Trying to write a zero to the event flag or a one when it is not set has no effect. |

Register ([mpcore](#)) Watchdog_Reset_Status_Register

| | |
|------------------|--------------------------------|
| Name | Watchdog_Reset_Status_Register |
| Relative Address | 0x00000630 |
| Absolute Address | 0xF8F00630 |
| Width | 32 bits |
| Access Type | rw |
| Reset Value | 0x00000000 |
| Description | Watchdog Reset Status Register |

Register Watchdog_Reset_Status_Register Details

| Field Name | Bits | Type | Reset Value | Description |
|------------|------|------|-------------|---|
| reserved | 31:1 | rw | 0x0 | Reserved. Writes are ignored, read data is always zero. |
| Reset_flag | 0 | rw | 0x0 | <p>The reset flag is a sticky bit that is automatically set when the Counter Register reaches zero and a reset request is sent accordingly. (In watchdog mode)</p> <p>The reset flag is cleared when written with a value of 1. Trying to write a zero to the reset flag or a one when it is not set has no effect. This flag is not reset by normal Cortex-A9 processor resets but has its own reset line, nWDRESET. nWDRESET must not be asserted when the Cortex-A9 processor reset assertion is the result of a watchdog reset request with WDRESETREQ. This distinction enables software to differentiate between a normal boot sequence, reset flag is zero, and one caused by a previous watchdog time-out, reset flag set to one.</p> |

Register ([mpcore](#)) Watchdog_Disable_Register

| | |
|------------------|---------------------------|
| Name | Watchdog_Disable_Register |
| Relative Address | 0x00000634 |
| Absolute Address | 0xF8F00634 |
| Width | 32 bits |
| Access Type | rw |
| Reset Value | 0x00000000 |
| Description | Watchdog Disable Register |

Register Watchdog_Disable_Register Details

| Field Name | Bits | Type | Reset Value | Description |
|------------|------|------|-------------|--|
| | 31:0 | rw | 0x0 | <p>Watchdog Disable Register</p> <p>Use the Watchdog Disable Register to switch from watchdog to timer mode. The software must write 0x12345678 then 0x87654321 successively to the Watchdog Disable Register so that the watchdog mode bit in the Watchdog Control Register is set to zero. If one of the values written to the Watchdog Disable Register is incorrect or if any other write occurs in between the two word writes, the watchdog remains in its current state. To reactivate the Watchdog, the software must write 1 to the watchdog mode bit of the Watchdog Control Register.</p> |

Register ([mpcore](#)) ICDDCR

| | |
|------------------|------------------------------|
| Name | ICDDCR |
| Relative Address | 0x00001000 |
| Absolute Address | 0xF8F01000 |
| Width | 32 bits |
| Access Type | rw |
| Reset Value | 0x00000000 |
| Description | Distributor Control Register |

Register ICDDCR Details

| Field Name | Bits | Type | Reset Value | Description |
|------------|------|------|-------------|---|
| reserved | 31:2 | rw | 0x0 | Reserved. Writes are ignored, read data is always zero. |

| Field Name | Bits | Type | Reset Value | Description |
|-------------------|------|------|-------------|--|
| Enable_Non_secure | 1 | rw | 0x0 | 0 = disables all Non-secure interrupts control bits in the distributor from changing state because of any external stimulus change that occurs on the corresponding SPI or PPI signals 1 = enables the distributor to update register locations for Non-secure interrupts FOR: ICDDCR_for_Non_secure_mode 31,1 --> Reserved. Writes are ignored, read data is always zero. |
| Enable_secure | 0 | rw | 0x0 | 0 = disables all Secure interrupt control bits in the distributor from changing state because of any external stimulus change that occurs on the corresponding SPI or PPI signals. 1 = enables the distributor to update register locations for Secure interrupts. FOR: ICDDCR_for_Non_secure_mode 0 --> Enable_Non_secure --> 0 = disables all Non-secure interrupts control bits in the distributor from changing state because of any external stimulus change that occurs on the corresponding SPI or PPI signals 1 = enables the distributor to update register locations for Non-secure interrupts |

Register ([mpcore](#)) ICDICTR

| | |
|------------------|------------------------------------|
| Name | ICDICTR |
| Relative Address | 0x00001004 |
| Absolute Address | 0xF8F01004 |
| Width | 32 bits |
| Access Type | ro |
| Reset Value | 0x0000FC22 |
| Description | Interrupt Controller Type Register |

Register ICDICTR Details

| Field Name | Bits | Type | Reset Value | Description |
|-----------------|-------|------|-------------|--|
| reserved | 31:29 | ro | 0x0 | Reserved. Writes are ignored, read data is always zero. |
| LSPI | 15:11 | ro | 0x1F | Returns the number of Lockable Shared Peripheral Interrupts (LSPIs) that the controller contains. The encoding is: b11111 = 31 LSPIs, which are the interrupts of IDs 32-62. When CFGSDISABLE is HIGH then the interrupt controller prevents writes to any register locations that control the operating state of an LSPI. |
| SecurityExtn | 10 | ro | 0x1 | Returns the number of security domains that the controller contains: 1 = the controller contains two security domains. This bit always returns the value one. |
| SBZ | 9:8 | ro | 0x0 | Reserved |
| CPU_Number | 7:5 | ro | 0x1 | The encoding is: b000 the Cortex-A9 MPCore configuration contains one Cortex-A9 processor. b001 the Cortex-A9 MPCore configuration contains two Cortex-A9 processors. b010 the Cortex-A9 MPCore configuration contains three Cortex-A9 processors. b011 the Cortex-A9 MPCore configuration contains four Cortex-A9 processors. b1xx: Unused values. |
| IT_Lines_Number | 4:0 | ro | 0x2 | The encoding is: b00000 = the distributor provides 32 interrupts, no external interrupt lines. b00001 = the distributor provides 64 interrupts, 32 external interrupt lines. b00010 = the distributor provides 96 interrupts, 64 external interrupt lines. b00011 = the distributor provide 128 interrupts, 96 external interrupt lines. b00100 = the distributor provides 160 interrupts, 128 external interrupt lines. b00101 = the distributor provides 192 interrupts, 160 external interrupt lines. b00110 = the distributor provides 224 interrupts, 192 external interrupt lines. b00111 = the distributor provides 256 interrupts, 224 external interrupt lines. All other values not used. |

Register ([mpcore](#)) ICDIIDR

| | |
|------------------|---|
| Name | ICDIIDR |
| Relative Address | 0x00001008 |
| Absolute Address | 0xF8F01008 |
| Width | 32 bits |
| Access Type | ro |
| Reset Value | 0x0102043B |
| Description | Distributor Implementer Identification Register |

Register ICDIIDR Details

| Field Name | Bits | Type | Reset Value | Description |
|------------------------|-------|------|-------------|--|
| Implementation_Version | 31:24 | ro | 0x1 | Gives implementation version number |
| Revision_Number | 23:12 | ro | 0x20 | Return the revision number of the controller |
| Implementer | 11:0 | ro | 0x43B | Implementer Number |

Register ([mpcore](#)) ICDISR0

| | |
|------------------|-------------------------------|
| Name | ICDISR0 |
| Relative Address | 0x00001080 |
| Absolute Address | 0xF8F01080 |
| Width | 32 bits |
| Access Type | rw |
| Reset Value | 0x00000000 |
| Description | Interrupt Security Register_0 |

Note: This register is the first in an array of 3 identical registers listed in the table below. The details provided in this section apply to the entire array.

| Name | Address |
|---------|------------|
| ICDISR0 | 0xf8f01080 |
| ICDISR1 | 0xf8f01084 |
| ICDISR2 | 0xf8f01088 |

Register ICDISR0 to ICDISR2 Details

| Field Name | Bits | Type | Reset Value | Description |
|-----------------|------|------|-------------|--|
| Security_Status | 31:0 | rw | 0x0 | The ICDISRn provide a Security status bit for each interrupt supported by the GIC. Each bit controls the security status of the corresponding interrupt. Accessible by Secure accesses only. The register addresses are RAZ/WI to Non-secure accesses. ICDISR0 is banked for each connected processor. |

Register ([mpcore](#)) ICDISER0

| | |
|------------------|---------------------------------|
| Name | ICDISER0 |
| Relative Address | 0x00001100 |
| Absolute Address | 0xF8F01100 |
| Width | 32 bits |
| Access Type | rw |
| Reset Value | 0x0000FFFF |
| Description | Interrupt Set-enable Register 0 |

Register ICDISER0 Details

| Field Name | Bits | Type | Reset Value | Description |
|------------|------|------|-------------|---|
| Set | 31:0 | rw | 0xFFFF | The ICDISERs provide a Set-enable bit for each interrupt supported by the GIC. Writing 1 to a Set-enable bit enables forwarding of the corresponding interrupt to the CPU interfaces. A register bit that corresponds to a Secure interrupt is RAZ/WI to Non-secure access. ICDISER0 is banked for each connected processor. |

Register ([mpcore](#)) ICDISER1

| | |
|------------------|---------------------------------|
| Name | ICDISER1 |
| Relative Address | 0x00001104 |
| Absolute Address | 0xF8F01104 |
| Width | 32 bits |
| Access Type | rw |
| Reset Value | 0x00000000 |
| Description | Interrupt Set-enable Register 1 |

Register ICDISER1 Details

| Field Name | Bits | Type | Reset Value | Description |
|------------|------|------|-------------|---|
| Set | 31:0 | rw | 0x0 | The ICDISERs provide a Set-enable bit for each interrupt supported by the GIC. Writing 1 to a Set-enable bit enables forwarding of the corresponding interrupt to the CPU interfaces. A register bit that corresponds to a Secure interrupt is RAZ/WI to Non-secure access. |

Register ([mpcore](#)) ICDISER2

| | |
|------------------|---------------------------------|
| Name | ICDISER2 |
| Relative Address | 0x00001108 |
| Absolute Address | 0xF8F01108 |
| Width | 32 bits |
| Access Type | rw |
| Reset Value | 0x00000000 |
| Description | Interrupt Set-enable Register 2 |

Register ICDISER2 Details

| Field Name | Bits | Type | Reset Value | Description |
|------------|------|------|-------------|---|
| Set | 31:0 | rw | 0x0 | The ICDISERs provide a Set-enable bit for each interrupt supported by the GIC. Writing 1 to a Set-enable bit enables forwarding of the corresponding interrupt to the CPU interfaces. A register bit that corresponds to a Secure interrupt is RAZ/WI to Non-secure access. |

Register ([mpcore](#)) ICDICERO

| | |
|------------------|-----------------------------------|
| Name | ICDICERO |
| Relative Address | 0x00001180 |
| Absolute Address | 0xF8F01180 |
| Width | 32 bits |
| Access Type | rw |
| Reset Value | 0x0000FFFF |
| Description | Interrupt Clear-Enable Register 0 |

Register ICDICER0 Details

| Field Name | Bits | Type | Reset Value | Description |
|------------|------|------|-------------|--|
| Clear | 31:0 | rw | 0xFFFF | The ICDICERs provide a Clear-enable bit for each interrupt supported by the GIC. Writing 1 to a Clear-enable bit disables forwarding of the corresponding interrupt to the CPU interfaces. A register bit that corresponds to a Secure interrupt is RAZ/WI to Non-secure accesses. ICDICER0 is banked for each connected processor. |

Register ([mpcore](#)) ICDICER1

| | |
|------------------|-----------------------------------|
| Name | ICDICER1 |
| Relative Address | 0x00001184 |
| Absolute Address | 0xF8F01184 |
| Width | 32 bits |
| Access Type | rw |
| Reset Value | 0x00000000 |
| Description | Interrupt Clear-Enable Register 1 |

Register ICDICER1 Details

| Field Name | Bits | Type | Reset Value | Description |
|------------|------|------|-------------|--|
| Clear | 31:0 | rw | 0x0 | The ICDICERs provide a Clear-enable bit for each interrupt supported by the GIC. Writing 1 to a Clear-enable bit disables forwarding of the corresponding interrupt to the CPU interfaces. A register bit that corresponds to a Secure interrupt is RAZ/WI to Non-secure accesses. |

Register ([mpcore](#)) ICDICER2

| | |
|------------------|-----------------------------------|
| Name | ICDICER2 |
| Relative Address | 0x00001188 |
| Absolute Address | 0xF8F01188 |
| Width | 32 bits |
| Access Type | rw |
| Reset Value | 0x00000000 |
| Description | Interrupt Clear-Enable Register 2 |

Register ICDICER2 Details

| Field Name | Bits | Type | Reset Value | Description |
|------------|------|------|-------------|--|
| Clear | 31:0 | rw | 0x0 | The ICDICERs provide a Clear-enable bit for each interrupt supported by the GIC. Writing 1 to a Clear-enable bit disables forwarding of the corresponding interrupt to the CPU interfaces. A register bit that corresponds to a Secure interrupt is RAZ/WI to Non-secure accesses. |

Register ([mpcore](#)) ICDISPR0

| | |
|------------------|----------------------------------|
| Name | ICDISPR0 |
| Relative Address | 0x00001200 |
| Absolute Address | 0xF8F01200 |
| Width | 32 bits |
| Access Type | rw |
| Reset Value | 0x00000000 |
| Description | Interrupt Set-pending Register_0 |

Note: This register is the first in an array of 3 identical registers listed in the table below. The details provided in this section apply to the entire array.

| Name | Address |
|----------|------------|
| ICDISPR0 | 0xf8f01200 |
| ICDISPR1 | 0xf8f01204 |
| ICDISPR2 | 0xf8f01208 |

Register ICDISPR0 to ICDISPR2 Details

| Field Name | Bits | Type | Reset Value | Description |
|------------|------|------|-------------|--|
| Set | 31:0 | rw | 0x0 | The ICDISPRs provide a Set-pending bit for each interrupt supported by the GIC. Writing 1 to a Set-pending bit sets the status of the corresponding peripheral interrupt to pending. A register bit that corresponds to a Secure interrupt is RAZ/WI to Non-secure accesses. ICDISPR0 is banked for each connected processor. |

Register ([mpcore](#)) ICDICPR0

| | |
|------|----------|
| Name | ICDICPR0 |
|------|----------|

| | |
|------------------|------------------------------------|
| Relative Address | 0x00001280 |
| Absolute Address | 0xF8F01280 |
| Width | 32 bits |
| Access Type | rw |
| Reset Value | 0x00000000 |
| Description | Interrupt Clear-Pending Register_0 |

Note: This register is the first in an array of 3 identical registers listed in the table below. The details provided in this section apply to the entire array.

| Name | Address |
|----------|------------|
| ICDICPR0 | 0xf8f01280 |
| ICDICPR1 | 0xf8f01284 |
| ICDICPR2 | 0xf8f01288 |

Register ICDICPR0 to ICDICPR2 Details

| Field Name | Bits | Type | Reset Value | Description |
|------------|------|------|-------------|--|
| Clear | 31:0 | rw | 0x0 | <p>The ICDICPRs provide a Clear-pending bit for each interrupt supported by the GIC.</p> <p>Writing 1 to a Clear-pending bit clears the status of the corresponding peripheral interrupt to pending.</p> <p>A register bit that corresponds to a Secure interrupt is RAZ/WI to Non-secure accesses. ICDICPR0 is banked for each connected processor.</p> |

Register ([mpcore](#)) ICDABR0

| | |
|------------------|-----------------------|
| Name | ICDABR0 |
| Relative Address | 0x00001300 |
| Absolute Address | 0xF8F01300 |
| Width | 32 bits |
| Access Type | rw |
| Reset Value | 0x00000000 |
| Description | Active Bit register_0 |

Note: This register is the first in an array of 3 identical registers listed in the table below. The details provided in this section apply to the entire array.

| Name | Address |
|---------|------------|
| ICDABR0 | 0xf8f01300 |
| ICDABR1 | 0xf8f01304 |
| ICDABR2 | 0xf8f01308 |

Register ICDABR0 to ICDABR2 Details

| Field Name | Bits | Type | Reset Value | Description |
|------------|------|------|-------------|---|
| Active | 31:0 | rw | 0x0 | The ICDABRs provide an Active bit for each interrupt supported by the GIC. The bit reads as one if the status of the interrupt is active or active and pending. Read the ICDSR or ICDCR to find the pending status of the interrupt. ICDABR0 is banked for each connected processor. |

Register ([mpcore](#)) ICDIPR0

| | |
|------------------|-------------------------------|
| Name | ICDIPR0 |
| Relative Address | 0x00001400 |
| Absolute Address | 0xF8F01400 |
| Width | 32 bits |
| Access Type | rw |
| Reset Value | 0x00000000 |
| Description | Interrupt Priority Register_0 |

Note: This register is the first in an array of 24 identical registers listed in the table below. The details provided in this section apply to the entire array.

| Name | Address |
|----------|------------|
| ICDIPR0 | 0xf8f01400 |
| ICDIPR1 | 0xf8f01404 |
| ICDIPR2 | 0xf8f01408 |
| ICDIPR3 | 0xf8f0140c |
| ICDIPR4 | 0xf8f01410 |
| ICDIPR5 | 0xf8f01414 |
| ICDIPR6 | 0xf8f01418 |
| ICDIPR7 | 0xf8f0141c |
| ICDIPR8 | 0xf8f01420 |
| ICDIPR9 | 0xf8f01424 |
| ICDIPR10 | 0xf8f01428 |

| Name | Address |
|----------|------------|
| ICDIPR11 | 0xf8f0142c |
| ICDIPR12 | 0xf8f01430 |
| ICDIPR13 | 0xf8f01434 |
| ICDIPR14 | 0xf8f01438 |
| ICDIPR15 | 0xf8f0143c |
| ICDIPR16 | 0xf8f01440 |
| ICDIPR17 | 0xf8f01444 |
| ICDIPR18 | 0xf8f01448 |
| ICDIPR19 | 0xf8f0144c |
| ICDIPR20 | 0xf8f01450 |
| ICDIPR21 | 0xf8f01454 |
| ICDIPR22 | 0xf8f01458 |
| ICDIPR23 | 0xf8f0145c |

Register ICDIPR0 to ICDIPR23 Details

| Field Name | Bits | Type | Reset Value | Description |
|------------|------|------|-------------|--|
| Priority | 31:0 | rw | 0x0 | <p>The ICDIPRs provide an 8-bit Priority field for each interrupt supported by the GIC; only the upper 5 bits of each 8-bit field are writable; the lower bits are always 0. There are 32 priority levels, all even values. These registers are byte accessible.</p> <p>A register field that corresponds to a Secure interrupt is RAZ/WI to Non-secure accesses. ICDIPR0 to ICDIPR7 are banked for each connected processor</p> |

Register ([mpcore](#)) ICDIPTR0

| | |
|------------------|--|
| Name | ICDIPTR0 |
| Relative Address | 0x00001800 |
| Absolute Address | 0xF8F01800 |
| Width | 32 bits |
| Access Type | ro |
| Reset Value | 0x01010101 |
| Description | Interrupt Processor Targets Register 0 |

Register ICDIPTR0 Details

The ICDIPTR0 register is used to indicate the targets of interrupts ID#0-ID#3.

| Field Name | Bits | Type | Reset Value | Description |
|------------|-------|------|-------------|--|
| target_3 | 25:24 | ro | 0x1 | Targeted CPU(s) for interrupt ID#3 01: CPU 0 targeted (CPU 0 always reads this value) 10: CPU 1 targeted (CPU 1 always reads this value) |
| target_2 | 17:16 | ro | 0x1 | Targeted CPU(s) for interrupt ID#2 01: CPU 0 targeted (CPU 0 always reads this value) 10: CPU 1 targeted (CPU 1 always reads this value) |
| target_1 | 9:8 | ro | 0x1 | Targeted CPU(s) for interrupt ID#1 01: CPU 0 targeted (CPU 0 always reads this value) 10: CPU 1 targeted (CPU 1 always reads this value) |
| target_0 | 1:0 | ro | 0x1 | Targeted CPU(s) for interrupt ID#0 01: CPU 0 targeted (CPU 0 always reads this value) 10: CPU 1 targeted (CPU 1 always reads this value) |

Register ([mpcore](#)) ICDIPTR1

| | |
|------------------|--|
| Name | ICDIPTR1 |
| Relative Address | 0x00001804 |
| Absolute Address | 0xF8F01804 |
| Width | 32 bits |
| Access Type | ro |
| Reset Value | 0x01010101 |
| Description | Interrupt Processor Targets Register 1 |

Register ICDIPTR1 Details

The ICDIPTR1 register is used to indicate the targets of interrupts ID#4-ID#7.

| Field Name | Bits | Type | Reset Value | Description |
|------------|-------|------|-------------|--|
| target_7 | 25:24 | ro | 0x1 | Targeted CPU(s) for interrupt ID#7 01: CPU 0 targeted (CPU 0 always reads this value) 10: CPU 1 targeted (CPU 1 always reads this value) |
| target_6 | 17:16 | ro | 0x1 | Targeted CPU(s) for interrupt ID#6 01: CPU 0 targeted (CPU 0 always reads this value) 10: CPU 1 targeted (CPU 1 always reads this value) |
| target_5 | 9:8 | ro | 0x1 | Targeted CPU(s) for interrupt ID#5 01: CPU 0 targeted (CPU 0 always reads this value) 10: CPU 1 targeted (CPU 1 always reads this value) |
| target_4 | 1:0 | ro | 0x1 | Targeted CPU(s) for interrupt ID#4 01: CPU 0 targeted (CPU 0 always reads this value) 10: CPU 1 targeted (CPU 1 always reads this value) |

Register ([mpcore](#)) ICDIPTR2

| | |
|------------------|--|
| Name | ICDIPTR2 |
| Relative Address | 0x00001808 |
| Absolute Address | 0xF8F01808 |
| Width | 32 bits |
| Access Type | ro |
| Reset Value | 0x01010101 |
| Description | Interrupt Processor Targets Register 2 |

Register ICDIPTR2 Details

The ICDIPTR2 register is used to indicate the targets of interrupts ID#8-ID#11.

| Field Name | Bits | Type | Reset Value | Description |
|------------|-------|------|-------------|---|
| target_11 | 25:24 | ro | 0x1 | Targeted CPU(s) for interrupt ID#11 01: CPU 0 targeted (CPU 0 always reads this value) 10: CPU 1 targeted (CPU 1 always reads this value) |
| target_10 | 17:16 | ro | 0x1 | Targeted CPU(s) for interrupt ID#10 01: CPU 0 targeted (CPU 0 always reads this value) 10: CPU 1 targeted (CPU 1 always reads this value) |
| target_9 | 9:8 | ro | 0x1 | Targeted CPU(s) for interrupt ID#9 01: CPU 0 targeted (CPU 0 always reads this value) 10: CPU 1 targeted (CPU 1 always reads this value) |
| target_8 | 1:0 | ro | 0x1 | Targeted CPU(s) for interrupt ID#8 01: CPU 0 targeted (CPU 0 always reads this value) 10: CPU 1 targeted (CPU 1 always reads this value) |

Register ([mpcore](#)) ICDIPTR3

| | |
|------------------|--|
| Name | ICDIPTR3 |
| Relative Address | 0x0000180C |
| Absolute Address | 0xF8F0180C |
| Width | 32 bits |
| Access Type | ro |
| Reset Value | 0x01010101 |
| Description | Interrupt Processor Targets Register 3 |

Register ICDIPTR3 Details

The ICDIPTR3 register is used to indicate the targets of interrupts ID#12-ID#15.

| Field Name | Bits | Type | Reset Value | Description |
|------------|-------|------|-------------|---|
| target_15 | 25:24 | ro | 0x1 | Targeted CPU(s) for interrupt ID#15 01: CPU 0 targeted (CPU 0 always reads this value) 10: CPU 1 targeted (CPU 1 always reads this value) |
| target_14 | 17:16 | ro | 0x1 | Targeted CPU(s) for interrupt ID#14 01: CPU 0 targeted (CPU 0 always reads this value) 10: CPU 1 targeted (CPU 1 always reads this value) |
| target_13 | 9:8 | ro | 0x1 | Targeted CPU(s) for interrupt ID#13 01: CPU 0 targeted (CPU 0 always reads this value) 10: CPU 1 targeted (CPU 1 always reads this value) |
| target_12 | 1:0 | ro | 0x1 | Targeted CPU(s) for interrupt ID#12 01: CPU 0 targeted (CPU 0 always reads this value) 10: CPU 1 targeted (CPU 1 always reads this value) |

Register ([mpcore](#)) ICDIPTR4

| | |
|------------------|--|
| Name | ICDIPTR4 |
| Relative Address | 0x00001810 |
| Absolute Address | 0xF8F01810 |
| Width | 32 bits |
| Access Type | rw |
| Reset Value | 0x00000000 |
| Description | Interrupt Processor Targets Register 4 |

Register ICDIPTR4 Details

The ICDIPTR4 register always returns 0.

| Field Name | Bits | Type | Reset Value | Description |
|------------|------|------|-------------|-------------|
| reserved | 31:0 | rw | 0x0 | Reserved |

Register ([mpcore](#)) ICDIPTR5

| | |
|------------------|--|
| Name | ICDIPTR5 |
| Relative Address | 0x00001814 |
| Absolute Address | 0xF8F01814 |
| Width | 32 bits |
| Access Type | ro |
| Reset Value | 0x00000000 |
| Description | Interrupt Processor Targets Register 5 |

Register ICDIPTR5 Details

The ICDIPTR5 register always returns 0.

| Field Name | Bits | Type | Reset Value | Description |
|------------|------|------|-------------|-------------|
| reserved | 31:0 | ro | 0x0 | Reserved |

Register ([mpcore](#)) ICDIPTR6

| | |
|------------------|--|
| Name | ICDIPTR6 |
| Relative Address | 0x00001818 |
| Absolute Address | 0xF8F01818 |
| Width | 32 bits |
| Access Type | ro |
| Reset Value | 0x01000000 |
| Description | Interrupt Processor Targets Register 6 |

Register ICDIPTR6 Details

The ICDIPTR6 register is used to indicate the target of interrupt ID#27.

| Field Name | Bits | Type | Reset Value | Description |
|------------|-------|------|-------------|---|
| target_27 | 25:24 | ro | 0x1 | Targeted CPU(s) for interrupt ID#27 01: CPU 0 targeted 10: CPU 1 targeted |

Register ([mpcore](#)) ICDIPTR7

| | |
|------------------|--|
| Name | ICDIPTR7 |
| Relative Address | 0x0000181C |
| Absolute Address | 0xF8F0181C |
| Width | 32 bits |
| Access Type | ro |
| Reset Value | 0x01010101 |
| Description | Interrupt Processor Targets Register 7 |

Register ICDIPTR7 Details

The ICDIPTR7 register is used to indicate the targets of interrupts ID#28-ID#31.

| Field Name | Bits | Type | Reset Value | Description |
|------------|-------|------|-------------|---|
| target_31 | 25:24 | ro | 0x1 | Targeted CPU(s) for interrupt ID#31 01: CPU 0 targeted 10: CPU 1 targeted |
| target_30 | 17:16 | ro | 0x1 | Targeted CPU(s) for interrupt ID#30 01: CPU 0 targeted 10: CPU 1 targeted |
| target_29 | 9:8 | ro | 0x1 | Targeted CPU(s) for interrupt ID#29 01: CPU 0 targeted 10: CPU 1 targeted |
| target_28 | 1:0 | ro | 0x1 | Targeted CPU(s) for interrupt ID#28 01: CPU 0 targeted 10: CPU 1 targeted |

Register ([mpcore](#)) ICDIPTR8

| | |
|------------------|--|
| Name | ICDIPTR8 |
| Relative Address | 0x00001820 |
| Absolute Address | 0xF8F01820 |
| Width | 32 bits |
| Access Type | rw |
| Reset Value | 0x00000000 |
| Description | Interrupt Processor Targets Register 8 |

Register ICDIPTR8 Details

The ICDIPTR8 register is used to target the interrupts ID#32-ID#35 to none, CPU 0, CPU 1, or both CPUs.

| Field Name | Bits | Type | Reset Value | Description |
|------------|-------|------|-------------|---|
| target_35 | 25:24 | rw | 0x0 | Targeted CPU(s) for interrupt ID#35 00: no CPU targeted 01: CPU 0 targeted 10: CPU 1 targeted 11: CPU 0 and CPU 1 are both targeted |
| target_34 | 17:16 | rw | 0x0 | Targeted CPU(s) for interrupt ID#34 00: no CPU targeted 01: CPU 0 targeted 10: CPU 1 targeted 11: CPU 0 and CPU 1 are both targeted |

| Field Name | Bits | Type | Reset Value | Description |
|------------|------|------|-------------|---|
| target_33 | 9:8 | rw | 0x0 | Targeted CPU(s) for interrupt ID#33 00: no CPU targeted 01: CPU 0 targeted 10: CPU 1 targeted 11: CPU 0 and CPU 1 are both targeted |
| target_32 | 1:0 | rw | 0x0 | Targeted CPU(s) for interrupt ID#32 00: no CPU targeted 01: CPU 0 targeted 10: CPU 1 targeted 11: CPU 0 and CPU 1 are both targeted |

Register ([mpcore](#)) ICDIPTR9

| | |
|------------------|--|
| Name | ICDIPTR9 |
| Relative Address | 0x00001824 |
| Absolute Address | 0xF8F01824 |
| Width | 32 bits |
| Access Type | rw |
| Reset Value | 0x00000000 |
| Description | Interrupt Processor Targets Register 9 |

Register ICDIPTR9 Details

The ICDIPTR9 register is used to target the interrupts ID#36-ID#39 to none, CPU 0, CPU 1, or both CPUs.

| Field Name | Bits | Type | Reset Value | Description |
|------------|-------|------|-------------|---|
| target_39 | 25:24 | rw | 0x0 | Targeted CPU(s) for interrupt ID#39 00: no CPU targeted 01: CPU 0 targeted 10: CPU 1 targeted 11: CPU 0 and CPU 1 are both targeted |
| target_38 | 17:16 | rw | 0x0 | Targeted CPU(s) for interrupt ID#38 00: no CPU targeted 01: CPU 0 targeted 10: CPU 1 targeted 11: CPU 0 and CPU 1 are both targeted |

| Field Name | Bits | Type | Reset Value | Description |
|------------|------|------|-------------|---|
| target_37 | 9:8 | rw | 0x0 | Targeted CPU(s) for interrupt ID#37 00: no CPU targeted 01: CPU 0 targeted 10: CPU 1 targeted 11: CPU 0 and CPU 1 are both targeted |
| target_36 | 1:0 | rw | 0x0 | Targeted CPU(s) for interrupt ID#36 00: no CPU targeted 01: CPU 0 targeted 10: CPU 1 targeted 11: CPU 0 and CPU 1 are both targeted |

Register ([mpcore](#)) ICDIPTR10

| | |
|------------------|---|
| Name | ICDIPTR10 |
| Relative Address | 0x00001828 |
| Absolute Address | 0xF8F01828 |
| Width | 32 bits |
| Access Type | rw |
| Reset Value | 0x00000000 |
| Description | Interrupt Processor Targets Register 10 |

Register ICDIPTR10 Details

The ICDIPTR10 register is used to target the interrupts ID#40-ID#43 to none, CPU 0, CPU 1, or both CPUs.

| Field Name | Bits | Type | Reset Value | Description |
|------------|-------|------|-------------|---|
| target_43 | 25:24 | rw | 0x0 | Targeted CPU(s) for interrupt ID#43 00: no CPU targeted 01: CPU 0 targeted 10: CPU 1 targeted 11: CPU 0 and CPU 1 are both targeted |
| target_42 | 17:16 | rw | 0x0 | Targeted CPU(s) for interrupt ID#42 00: no CPU targeted 01: CPU 0 targeted 10: CPU 1 targeted 11: CPU 0 and CPU 1 are both targeted |

| Field Name | Bits | Type | Reset Value | Description |
|------------|------|------|-------------|---|
| target_41 | 9:8 | rw | 0x0 | Targeted CPU(s) for interrupt ID#41 00: no CPU targeted 01: CPU 0 targeted 10: CPU 1 targeted 11: CPU 0 and CPU 1 are both targeted |
| target_40 | 1:0 | rw | 0x0 | Targeted CPU(s) for interrupt ID#40 00: no CPU targeted 01: CPU 0 targeted 10: CPU 1 targeted 11: CPU 0 and CPU 1 are both targeted |

Register ([mpcore](#)) ICDIPTR11

| | |
|------------------|---|
| Name | ICDIPTR11 |
| Relative Address | 0x0000182C |
| Absolute Address | 0xF8F0182C |
| Width | 32 bits |
| Access Type | rw |
| Reset Value | 0x00000000 |
| Description | Interrupt Processor Targets Register 11 |

Register ICDIPTR11 Details

The ICDIPTR11 register is used to target the interrupts ID#44-ID#47 to none, CPU 0, CPU 1, or both CPUs.

| Field Name | Bits | Type | Reset Value | Description |
|------------|-------|------|-------------|---|
| target_47 | 25:24 | rw | 0x0 | Targeted CPU(s) for interrupt ID#47 00: no CPU targeted 01: CPU 0 targeted 10: CPU 1 targeted 11: CPU 0 and CPU 1 are both targeted |
| target_46 | 17:16 | rw | 0x0 | Targeted CPU(s) for interrupt ID#46 00: no CPU targeted 01: CPU 0 targeted 10: CPU 1 targeted 11: CPU 0 and CPU 1 are both targeted |

| Field Name | Bits | Type | Reset Value | Description |
|------------|------|------|-------------|---|
| target_45 | 9:8 | rw | 0x0 | Targeted CPU(s) for interrupt ID#45 00: no CPU targeted 01: CPU 0 targeted 10: CPU 1 targeted 11: CPU 0 and CPU 1 are both targeted |
| target_44 | 1:0 | rw | 0x0 | Targeted CPU(s) for interrupt ID#44 00: no CPU targeted 01: CPU 0 targeted 10: CPU 1 targeted 11: CPU 0 and CPU 1 are both targeted |

Register ([mpcore](#)) ICDIPTR12

| | |
|------------------|---|
| Name | ICDIPTR12 |
| Relative Address | 0x00001830 |
| Absolute Address | 0xF8F01830 |
| Width | 32 bits |
| Access Type | rw |
| Reset Value | 0x00000000 |
| Description | Interrupt Processor Targets Register 12 |

Register ICDIPTR12 Details

The ICDIPTR12 register is used to target the interrupts ID#48-ID#51 to none, CPU 0, CPU 1, or both CPUs.

| Field Name | Bits | Type | Reset Value | Description |
|------------|-------|------|-------------|---|
| target_51 | 25:24 | rw | 0x0 | Targeted CPU(s) for interrupt ID#51 00: no CPU targeted 01: CPU 0 targeted 10: CPU 1 targeted 11: CPU 0 and CPU 1 are both targeted |
| target_50 | 17:16 | rw | 0x0 | Targeted CPU(s) for interrupt ID#50 00: no CPU targeted 01: CPU 0 targeted 10: CPU 1 targeted 11: CPU 0 and CPU 1 are both targeted |

| Field Name | Bits | Type | Reset Value | Description |
|------------|------|------|-------------|---|
| target_49 | 9:8 | rw | 0x0 | Targeted CPU(s) for interrupt ID#49 00: no CPU targeted 01: CPU 0 targeted 10: CPU 1 targeted 11: CPU 0 and CPU 1 are both targeted |
| target_48 | 1:0 | rw | 0x0 | Targeted CPU(s) for interrupt ID#48 00: no CPU targeted 01: CPU 0 targeted 10: CPU 1 targeted 11: CPU 0 and CPU 1 are both targeted |

Register ([mpcore](#)) ICDIPTR13

| | |
|------------------|---|
| Name | ICDIPTR13 |
| Relative Address | 0x00001834 |
| Absolute Address | 0xF8F01834 |
| Width | 32 bits |
| Access Type | rw |
| Reset Value | 0x00000000 |
| Description | Interrupt Processor Targets Register 13 |

Register ICDIPTR13 Details

The ICDIPTR13 register is used to target the interrupts ID#52-ID#55 to none, CPU 0, CPU 1, or both CPUs.

| Field Name | Bits | Type | Reset Value | Description |
|------------|-------|------|-------------|---|
| target_55 | 25:24 | rw | 0x0 | Targeted CPU(s) for interrupt ID#55 00: no CPU targeted 01: CPU 0 targeted 10: CPU 1 targeted 11: CPU 0 and CPU 1 are both targeted |
| target_54 | 17:16 | rw | 0x0 | Targeted CPU(s) for interrupt ID#54 00: no CPU targeted 01: CPU 0 targeted 10: CPU 1 targeted 11: CPU 0 and CPU 1 are both targeted |

| Field Name | Bits | Type | Reset Value | Description |
|------------|------|------|-------------|---|
| target_53 | 9:8 | rw | 0x0 | Targeted CPU(s) for interrupt ID#53 00: no CPU targeted 01: CPU 0 targeted 10: CPU 1 targeted 11: CPU 0 and CPU 1 are both targeted |
| target_52 | 1:0 | rw | 0x0 | Targeted CPU(s) for interrupt ID#52 00: no CPU targeted 01: CPU 0 targeted 10: CPU 1 targeted 11: CPU 0 and CPU 1 are both targeted |

Register ([mpcore](#)) ICDIPTR14

| | |
|------------------|---|
| Name | ICDIPTR14 |
| Relative Address | 0x00001838 |
| Absolute Address | 0xF8F01838 |
| Width | 32 bits |
| Access Type | rw |
| Reset Value | 0x00000000 |
| Description | Interrupt Processor Targets Register 14 |

Register ICDIPTR14 Details

The ICDIPTR14 register is used to target the interrupts ID#56-ID#59 to none, CPU 0, CPU 1, or both CPUs.

| Field Name | Bits | Type | Reset Value | Description |
|------------|-------|------|-------------|---|
| target_59 | 25:24 | rw | 0x0 | Targeted CPU(s) for interrupt ID#59 00: no CPU targeted 01: CPU 0 targeted 10: CPU 1 targeted 11: CPU 0 and CPU 1 are both targeted |
| target_58 | 17:16 | rw | 0x0 | Targeted CPU(s) for interrupt ID#58 00: no CPU targeted 01: CPU 0 targeted 10: CPU 1 targeted 11: CPU 0 and CPU 1 are both targeted |

| Field Name | Bits | Type | Reset Value | Description |
|------------|------|------|-------------|---|
| target_57 | 9:8 | rw | 0x0 | Targeted CPU(s) for interrupt ID#57 00: no CPU targeted 01: CPU 0 targeted 10: CPU 1 targeted 11: CPU 0 and CPU 1 are both targeted |
| target_56 | 1:0 | rw | 0x0 | Targeted CPU(s) for interrupt ID#56 00: no CPU targeted 01: CPU 0 targeted 10: CPU 1 targeted 11: CPU 0 and CPU 1 are both targeted |

Register ([mpcore](#)) ICDIPTR15

| | |
|------------------|---|
| Name | ICDIPTR15 |
| Relative Address | 0x0000183C |
| Absolute Address | 0xF8F0183C |
| Width | 32 bits |
| Access Type | rw |
| Reset Value | 0x00000000 |
| Description | Interrupt Processor Targets Register 15 |

Register ICDIPTR15 Details

The ICDIPTR15 register is used to target the interrupts ID#60-ID#63 to none, CPU 0, CPU 1, or both CPUs.

| Field Name | Bits | Type | Reset Value | Description |
|------------|-------|------|-------------|---|
| target_63 | 25:24 | rw | 0x0 | Targeted CPU(s) for interrupt ID#63 00: no CPU targeted 01: CPU 0 targeted 10: CPU 1 targeted 11: CPU 0 and CPU 1 are both targeted |
| target_62 | 17:16 | rw | 0x0 | Targeted CPU(s) for interrupt ID#62 00: no CPU targeted 01: CPU 0 targeted 10: CPU 1 targeted 11: CPU 0 and CPU 1 are both targeted |

| Field Name | Bits | Type | Reset Value | Description |
|------------|------|------|-------------|---|
| target_61 | 9:8 | rw | 0x0 | Targeted CPU(s) for interrupt ID#61 00: no CPU targeted 01: CPU 0 targeted 10: CPU 1 targeted 11: CPU 0 and CPU 1 are both targeted |
| target_60 | 1:0 | rw | 0x0 | Targeted CPU(s) for interrupt ID#60 00: no CPU targeted 01: CPU 0 targeted 10: CPU 1 targeted 11: CPU 0 and CPU 1 are both targeted |

Register ([mpcore](#)) ICDIPTR16

| | |
|------------------|---|
| Name | ICDIPTR16 |
| Relative Address | 0x00001840 |
| Absolute Address | 0xF8F01840 |
| Width | 32 bits |
| Access Type | rw |
| Reset Value | 0x00000000 |
| Description | Interrupt Processor Targets Register 16 |

Register ICDIPTR16 Details

The ICDIPTR16 register is used to target the interrupts ID#64-ID#67 to none, CPU 0, CPU 1, or both CPUs.

| Field Name | Bits | Type | Reset Value | Description |
|------------|-------|------|-------------|---|
| target_67 | 25:24 | rw | 0x0 | Targeted CPU(s) for interrupt ID#67 00: no CPU targeted 01: CPU 0 targeted 10: CPU 1 targeted 11: CPU 0 and CPU 1 are both targeted |
| target_66 | 17:16 | rw | 0x0 | Targeted CPU(s) for interrupt ID#66 00: no CPU targeted 01: CPU 0 targeted 10: CPU 1 targeted 11: CPU 0 and CPU 1 are both targeted |

| Field Name | Bits | Type | Reset Value | Description |
|------------|------|------|-------------|---|
| target_65 | 9:8 | rw | 0x0 | Targeted CPU(s) for interrupt ID#65 00: no CPU targeted 01: CPU 0 targeted 10: CPU 1 targeted 11: CPU 0 and CPU 1 are both targeted |
| target_64 | 1:0 | rw | 0x0 | Targeted CPU(s) for interrupt ID#64 00: no CPU targeted 01: CPU 0 targeted 10: CPU 1 targeted 11: CPU 0 and CPU 1 are both targeted |

Register ([mpcore](#)) ICDIPTR17

| | |
|------------------|---|
| Name | ICDIPTR17 |
| Relative Address | 0x00001844 |
| Absolute Address | 0xF8F01844 |
| Width | 32 bits |
| Access Type | rw |
| Reset Value | 0x00000000 |
| Description | Interrupt Processor Targets Register 17 |

Register ICDIPTR17 Details

The ICDIPTR17 register is used to target the interrupts ID#68-ID#71 to none, CPU 0, CPU 1, or both CPUs.

| Field Name | Bits | Type | Reset Value | Description |
|------------|-------|------|-------------|---|
| target_71 | 25:24 | rw | 0x0 | Targeted CPU(s) for interrupt ID#71 00: no CPU targeted 01: CPU 0 targeted 10: CPU 1 targeted 11: CPU 0 and CPU 1 are both targeted |
| target_70 | 17:16 | rw | 0x0 | Targeted CPU(s) for interrupt ID#70 00: no CPU targeted 01: CPU 0 targeted 10: CPU 1 targeted 11: CPU 0 and CPU 1 are both targeted |

| Field Name | Bits | Type | Reset Value | Description |
|------------|------|------|-------------|---|
| target_69 | 9:8 | rw | 0x0 | Targeted CPU(s) for interrupt ID#69 00: no CPU targeted 01: CPU 0 targeted 10: CPU 1 targeted 11: CPU 0 and CPU 1 are both targeted |
| target_68 | 1:0 | rw | 0x0 | Targeted CPU(s) for interrupt ID#68 00: no CPU targeted 01: CPU 0 targeted 10: CPU 1 targeted 11: CPU 0 and CPU 1 are both targeted |

Register ([mpcore](#)) ICDIPTR18

| | |
|------------------|---|
| Name | ICDIPTR18 |
| Relative Address | 0x00001848 |
| Absolute Address | 0xF8F01848 |
| Width | 32 bits |
| Access Type | rw |
| Reset Value | 0x00000000 |
| Description | Interrupt Processor Targets Register 18 |

Register ICDIPTR18 Details

The ICDIPTR18 register is used to target the interrupts ID#72-ID#75 to none, CPU 0, CPU 1, or both CPUs.

| Field Name | Bits | Type | Reset Value | Description |
|------------|-------|------|-------------|---|
| target_75 | 25:24 | rw | 0x0 | Targeted CPU(s) for interrupt ID#75 00: no CPU targeted 01: CPU 0 targeted 10: CPU 1 targeted 11: CPU 0 and CPU 1 are both targeted |
| target_74 | 17:16 | rw | 0x0 | Targeted CPU(s) for interrupt ID#74 00: no CPU targeted 01: CPU 0 targeted 10: CPU 1 targeted 11: CPU 0 and CPU 1 are both targeted |

| Field Name | Bits | Type | Reset Value | Description |
|------------|------|------|-------------|---|
| target_73 | 9:8 | rw | 0x0 | Targeted CPU(s) for interrupt ID#73 00: no CPU targeted 01: CPU 0 targeted 10: CPU 1 targeted 11: CPU 0 and CPU 1 are both targeted |
| target_72 | 1:0 | rw | 0x0 | Targeted CPU(s) for interrupt ID#72 00: no CPU targeted 01: CPU 0 targeted 10: CPU 1 targeted 11: CPU 0 and CPU 1 are both targeted |

Register ([mpcore](#)) ICDIPTR19

| | |
|------------------|---|
| Name | ICDIPTR19 |
| Relative Address | 0x0000184C |
| Absolute Address | 0xF8F0184C |
| Width | 32 bits |
| Access Type | rw |
| Reset Value | 0x00000000 |
| Description | Interrupt Processor Targets Register 19 |

Register ICDIPTR19 Details

The ICDIPTR19 register is used to target the interrupts ID#76-ID#79 to none, CPU 0, CPU 1, or both CPUs.

| Field Name | Bits | Type | Reset Value | Description |
|------------|-------|------|-------------|---|
| target_79 | 25:24 | rw | 0x0 | Targeted CPU(s) for interrupt ID#79 00: no CPU targeted 01: CPU 0 targeted 10: CPU 1 targeted 11: CPU 0 and CPU 1 are both targeted |
| target_78 | 17:16 | rw | 0x0 | Targeted CPU(s) for interrupt ID#78 00: no CPU targeted 01: CPU 0 targeted 10: CPU 1 targeted 11: CPU 0 and CPU 1 are both targeted |

| Field Name | Bits | Type | Reset Value | Description |
|------------|------|------|-------------|---|
| target_77 | 9:8 | rw | 0x0 | Targeted CPU(s) for interrupt ID#77 00: no CPU targeted 01: CPU 0 targeted 10: CPU 1 targeted 11: CPU 0 and CPU 1 are both targeted |
| target_76 | 1:0 | rw | 0x0 | Targeted CPU(s) for interrupt ID#76 00: no CPU targeted 01: CPU 0 targeted 10: CPU 1 targeted 11: CPU 0 and CPU 1 are both targeted |

Register ([mpcore](#)) ICDIPTR20

| | |
|------------------|---|
| Name | ICDIPTR20 |
| Relative Address | 0x00001850 |
| Absolute Address | 0xF8F01850 |
| Width | 32 bits |
| Access Type | rw |
| Reset Value | 0x00000000 |
| Description | Interrupt Processor Targets Register 20 |

Register ICDIPTR20 Details

The ICDIPTR20 register is used to target the interrupts ID#80-ID#83 to none, CPU 0, CPU 1, or both CPUs.

| Field Name | Bits | Type | Reset Value | Description |
|------------|-------|------|-------------|---|
| target_83 | 25:24 | rw | 0x0 | Targeted CPU(s) for interrupt ID#83 00: no CPU targeted 01: CPU 0 targeted 10: CPU 1 targeted 11: CPU 0 and CPU 1 are both targeted |
| target_82 | 17:16 | rw | 0x0 | Targeted CPU(s) for interrupt ID#82 00: no CPU targeted 01: CPU 0 targeted 10: CPU 1 targeted 11: CPU 0 and CPU 1 are both targeted |

| Field Name | Bits | Type | Reset Value | Description |
|------------|------|------|-------------|---|
| target_81 | 9:8 | rw | 0x0 | Targeted CPU(s) for interrupt ID#81 00: no CPU targeted 01: CPU 0 targeted 10: CPU 1 targeted 11: CPU 0 and CPU 1 are both targeted |
| target_80 | 1:0 | rw | 0x0 | Targeted CPU(s) for interrupt ID#80 00: no CPU targeted 01: CPU 0 targeted 10: CPU 1 targeted 11: CPU 0 and CPU 1 are both targeted |

Register ([mpcore](#)) ICDIPTR21

| | |
|------------------|---|
| Name | ICDIPTR21 |
| Relative Address | 0x00001854 |
| Absolute Address | 0xF8F01854 |
| Width | 32 bits |
| Access Type | rw |
| Reset Value | 0x00000000 |
| Description | Interrupt Processor Targets Register 21 |

Register ICDIPTR21 Details

The ICDIPTR21 register is used to target the interrupts ID#84-ID#87 to none, CPU 0, CPU 1, or both CPUs.

| Field Name | Bits | Type | Reset Value | Description |
|------------|-------|------|-------------|---|
| target_87 | 25:24 | rw | 0x0 | Targeted CPU(s) for interrupt ID#87 00: no CPU targeted 01: CPU 0 targeted 10: CPU 1 targeted 11: CPU 0 and CPU 1 are both targeted |
| target_86 | 17:16 | rw | 0x0 | Targeted CPU(s) for interrupt ID#86 00: no CPU targeted 01: CPU 0 targeted 10: CPU 1 targeted 11: CPU 0 and CPU 1 are both targeted |

| Field Name | Bits | Type | Reset Value | Description |
|------------|------|------|-------------|---|
| target_85 | 9:8 | rw | 0x0 | Targeted CPU(s) for interrupt ID#85 00: no CPU targeted 01: CPU 0 targeted 10: CPU 1 targeted 11: CPU 0 and CPU 1 are both targeted |
| target_84 | 1:0 | rw | 0x0 | Targeted CPU(s) for interrupt ID#84 00: no CPU targeted 01: CPU 0 targeted 10: CPU 1 targeted 11: CPU 0 and CPU 1 are both targeted |

Register ([mpcore](#)) ICDIPTR22

| | |
|------------------|---|
| Name | ICDIPTR22 |
| Relative Address | 0x00001858 |
| Absolute Address | 0xF8F01858 |
| Width | 32 bits |
| Access Type | rw |
| Reset Value | 0x00000000 |
| Description | Interrupt Processor Targets Register 22 |

Register ICDIPTR22 Details

The ICDIPTR22 register is used to target the interrupts ID#88-ID#91 to none, CPU 0, CPU 1, or both CPUs.

| Field Name | Bits | Type | Reset Value | Description |
|------------|-------|------|-------------|---|
| target_91 | 25:24 | rw | 0x0 | Targeted CPU(s) for interrupt ID#91 00: no CPU targeted 01: CPU 0 targeted 10: CPU 1 targeted 11: CPU 0 and CPU 1 are both targeted |
| target_90 | 17:16 | rw | 0x0 | Targeted CPU(s) for interrupt ID#90 00: no CPU targeted 01: CPU 0 targeted 10: CPU 1 targeted 11: CPU 0 and CPU 1 are both targeted |

| Field Name | Bits | Type | Reset Value | Description |
|------------|------|------|-------------|---|
| target_89 | 9:8 | rw | 0x0 | Targeted CPU(s) for interrupt ID#89 00: no CPU targeted 01: CPU 0 targeted 10: CPU 1 targeted 11: CPU 0 and CPU 1 are both targeted |
| target_88 | 1:0 | rw | 0x0 | Targeted CPU(s) for interrupt ID#88 00: no CPU targeted 01: CPU 0 targeted 10: CPU 1 targeted 11: CPU 0 and CPU 1 are both targeted |

Register ([mpcore](#)) ICDIPTR23

| | |
|------------------|---|
| Name | ICDIPTR23 |
| Relative Address | 0x0000185C |
| Absolute Address | 0xF8F0185C |
| Width | 32 bits |
| Access Type | rw |
| Reset Value | 0x00000000 |
| Description | Interrupt Processor Targets Register 23 |

Register ICDIPTR23 Details

The ICDIPTR23 register is used to target the interrupts ID#92-ID#95 to none, CPU 0, CPU 1, or both CPUs.

| Field Name | Bits | Type | Reset Value | Description |
|------------|-------|------|-------------|---|
| target_95 | 25:24 | rw | 0x0 | Targeted CPU(s) for interrupt ID#95 00: no CPU targeted 01: CPU 0 targeted 10: CPU 1 targeted 11: CPU 0 and CPU 1 are both targeted |
| target_94 | 17:16 | rw | 0x0 | Targeted CPU(s) for interrupt ID#94 00: no CPU targeted 01: CPU 0 targeted 10: CPU 1 targeted 11: CPU 0 and CPU 1 are both targeted |

| Field Name | Bits | Type | Reset Value | Description |
|------------|------|------|-------------|---|
| target_93 | 9:8 | rw | 0x0 | Targeted CPU(s) for interrupt ID#93 00: no CPU targeted 01: CPU 0 targeted 10: CPU 1 targeted 11: CPU 0 and CPU 1 are both targeted |
| target_92 | 1:0 | rw | 0x0 | Targeted CPU(s) for interrupt ID#92 00: no CPU targeted 01: CPU 0 targeted 10: CPU 1 targeted 11: CPU 0 and CPU 1 are both targeted |

Register ([mpcore](#)) ICDICFR0

| | |
|------------------|------------------------------------|
| Name | ICDICFR0 |
| Relative Address | 0x00001C00 |
| Absolute Address | 0xF8F01C00 |
| Width | 32 bits |
| Access Type | ro |
| Reset Value | 0xAAAAAAAA |
| Description | Interrupt Configuration Register 0 |

Register ICDICFR0 Details

The ICD ICFR 0 register controls the interrupt sensitivity of the 16 Software Generated Interrupts (SGI), IRQ ID #0 to ID #15. This read-only register has two bits per interrupt that always indicate each SGI interrupt is edge sensitive and must be handled by all of the targeted CPUs as indicated in the ICD IPTR [3:0] registers.

| Field Name | Bits | Type | Reset Value | Description |
|------------|-------|------|-------------|---|
| config_15 | 31:30 | ro | 0x2 | Configuration for interrupt ID#15 10: edge sensitive and must be handled by the targeted CPU(s). |
| config_14 | 29:28 | ro | 0x2 | Configuration for interrupt ID#14 10: edge sensitive and must be handled by the targeted CPU(s). |
| config_13 | 27:26 | ro | 0x2 | Configuration for interrupt ID#13 10: edge sensitive and must be handled by the targeted CPU(s). |
| config_12 | 25:24 | ro | 0x2 | Configuration for interrupt ID#12 10: edge sensitive and must be handled by the targeted CPU(s). |

| Field Name | Bits | Type | Reset Value | Description |
|------------|-------|------|-------------|---|
| config_11 | 23:22 | ro | 0x2 | Configuration for interrupt ID#11 10: edge sensitive and must be handled by the targeted CPU(s). |
| config_10 | 21:20 | ro | 0x2 | Configuration for interrupt ID#10 10: edge sensitive and must be handled by the targeted CPU(s). |
| config_9 | 19:18 | ro | 0x2 | Configuration for interrupt ID#9 10: edge sensitive and must be handled by the targeted CPU(s). |
| config_8 | 17:16 | ro | 0x2 | Configuration for interrupt ID#8 10: edge sensitive and must be handled by the targeted CPU(s). |
| config_7 | 15:14 | ro | 0x2 | Configuration for interrupt ID#7 10: edge sensitive and must be handled by the targeted CPU(s). |
| config_6 | 13:12 | ro | 0x2 | Configuration for interrupt ID#6 10: edge sensitive and must be handled by the targeted CPU(s). |
| config_5 | 11:10 | ro | 0x2 | Configuration for interrupt ID#5 10: edge sensitive and must be handled by the targeted CPU(s). |
| config_4 | 9:8 | ro | 0x2 | Configuration for interrupt ID#4 10: edge sensitive and must be handled by the targeted CPU(s). |
| config_3 | 7:6 | ro | 0x2 | Configuration for interrupt ID#3 10: edge sensitive and must be handled by the targeted CPU(s). |
| config_2 | 5:4 | ro | 0x2 | Configuration for interrupt ID#2 10: edge sensitive and must be handled by the targeted CPU(s). |
| config_1 | 3:2 | ro | 0x2 | Configuration for interrupt ID#1 10: edge sensitive and must be handled by the targeted CPU(s). |
| config_0 | 1:0 | ro | 0x2 | Configuration for interrupt ID#0 10: edge sensitive and must be handled by the targeted CPU(s). |

Register ([mpcore](#)) ICDICFR1

Name ICDICFR1
 Relative Address 0x00001C04
 Absolute Address 0xF8F01C04
 Width 32 bits
 Access Type rw

Reset Value 0x7DC00000
 Description Interrupt Configuration Register 1

Register ICDICFR1 Details

The ICD ICFR 1 register controls the interrupt sensitivity of the CPU Private Peripheral Interrupts (PPI), IRQ ID #27 to ID #31. This read-only register has two bits per interrupt. This two bit field is either equal to 01 (low-level active) or equal to 11 (edge sensitive). The LSB is always 1 because only the local CPU handles its own PPI interrupts.

Note: There are two instances of this register at the same address. One register is accessible by CPU 0 and the other register is accessible by CPU 1.

| Field Name | Bits | Type | Reset Value | Description |
|------------|-------|------|-------------|--|
| config_31 | 31:30 | rw | 0x1 | Configuration for interrupt ID#31 (nIRQ) 01: low-level active |
| config_30 | 29:28 | rw | 0x3 | Configuration for interrupt ID#30 (CPU watchdog timer) 11: edge sensitive |
| config_29 | 27:26 | rw | 0x3 | Configuration for interrupt ID#29 (CPU private timer) 11: edge sensitive |
| config_28 | 25:24 | rw | 0x1 | Configuration for interrupt ID#28 (nFIQ) 01: low-level active |
| config_27 | 23:22 | rw | 0x3 | Configuration for interrupt ID#27 (global timer) 11: edge sensitive |
| reserved | 21:0 | rw | 0x0 | Reserved |

Register ([mpcore](#)) ICDICFR2

Name ICDICFR2
 Relative Address 0x00001C08
 Absolute Address 0xF8F01C08
 Width 32 bits
 Access Type rw
 Reset Value 0x55555555
 Description Interrupt Configuration Register 2

Register ICDICFR2 Details

The ICDICFR 2 register control the interrupt sensitivity of the Shared Peripheral Interrupts (SPI), IRQ ID #32 to ID #47 (IRQ 36 is reserved). This register has two bits per interrupt. This two bit field is either equal to 01 (high-level active) or equal to 11 (rising-edge sensitive). The LSB is always 1 because only one CPU will handle a SPI interrupt, regardless of the number of CPUs targeted.

Refer to UG585 TRM Section 7.2.3 Shared Peripheral Interrupts (SPI) for the required sensitivity type for the SPI interrupts. The SPI interrupts must match the expected sensitivity. Interrupts from the PL may be high-level or rising edge sensitive; this must be coordinated with the PL hardware and software.

| Field Name | Bits | Type | Reset Value | Description |
|------------|-------|------|-------------|--|
| config_47 | 31:30 | rw | 0x1 | Configuration for interrupt ID#47 01: high-level active 11: rising-edge The lower bit is read-only and is always 1. |
| config_46 | 29:28 | rw | 0x1 | Configuration for interrupt ID#46 01: high-level active 11: rising-edge The lower bit is read-only and is always 1. |
| config_45 | 27:26 | rw | 0x1 | Configuration for interrupt ID#45 01: high-level active 11: rising-edge The lower bit is read-only and is always 1. |
| config_44 | 25:24 | rw | 0x1 | Configuration for interrupt ID#44 01: high-level active 11: rising-edge The lower bit is read-only and is always 1. |
| config_43 | 23:22 | rw | 0x1 | Configuration for interrupt ID#43 01: high-level active 11: rising-edge The lower bit is read-only and is always 1. |
| config_42 | 21:20 | rw | 0x1 | Configuration for interrupt ID#42 01: high-level active 11: rising-edge The lower bit is read-only and is always 1. |
| config_41 | 19:18 | rw | 0x1 | Configuration for interrupt ID#41 01: high-level active 11: rising-edge The lower bit is read-only and is always 1. |
| config_40 | 17:16 | rw | 0x1 | Configuration for interrupt ID#40 01: high-level active 11: rising-edge The lower bit is read-only and is always 1. |
| config_39 | 15:14 | rw | 0x1 | Configuration for interrupt ID#39 01: high-level active 11: rising-edge The lower bit is read-only and is always 1. |
| config_38 | 13:12 | rw | 0x1 | Configuration for interrupt ID#38 01: high-level active 11: rising-edge The lower bit is read-only and is always 1. |

| Field Name | Bits | Type | Reset Value | Description |
|------------|-------|------|-------------|--|
| config_37 | 11:10 | rw | 0x1 | Configuration for interrupt ID#37 01: high-level active 11: rising-edge The lower bit is read-only and is always 1. |
| config_36 | 9:8 | rw | 0x1 | Configuration for interrupt ID#36 01: high-level active 11: rising-edge The lower bit is read-only and is always 1. |
| config_35 | 7:6 | rw | 0x1 | Configuration for interrupt ID#35 01: high-level active 11: rising-edge The lower bit is read-only and is always 1. |
| config_34 | 5:4 | rw | 0x1 | Configuration for interrupt ID#34 01: high-level active 11: rising-edge The lower bit is read-only and is always 1. |
| config_33 | 3:2 | rw | 0x1 | Configuration for interrupt ID#33 01: high-level active 11: rising-edge The lower bit is read-only and is always 1. |
| config_32 | 1:0 | rw | 0x1 | Configuration for interrupt ID#32 01: high-level active 11: rising-edge The lower bit is read-only and is always 1. |

Register ([mpcore](#)) ICDICFR3

| | |
|------------------|------------------------------------|
| Name | ICDICFR3 |
| Relative Address | 0x00001C0C |
| Absolute Address | 0xF8F01C0C |
| Width | 32 bits |
| Access Type | rw |
| Reset Value | 0x55555555 |
| Description | Interrupt Configuration Register 3 |

Register ICDICFR3 Details

The ICDICFR 3 register control the interrupt sensitivity of the Shared Peripheral Interrupts (SPI), IRQ ID #48 to ID #63. This register has two bits per interrupt. This two bit field is either equal to 01 (high-level active) or equal to 11 (rising-edge sensitive). The LSB is always 1 because only one CPU will handle a SPI interrupt, regardless of the number of CPUs targeted.

Refer to UG585 TRM Section 7.2.3 Shared Peripheral Interrupts (SPI) for the required sensitivity type for the SPI interrupts. The SPI interrupts must match the expected sensitivity. Interrupts from the PL

may be high-level or rising edge sensitive; this must be coordinated with the PL hardware and software.

| Field Name | Bits | Type | Reset Value | Description |
|------------|-------|------|-------------|--|
| config_63 | 31:30 | rw | 0x1 | Configuration for interrupt ID#63 01: high-level active 11: rising-edge The lower bit is read-only and is always 1. |
| config_62 | 29:28 | rw | 0x1 | Configuration for interrupt ID#62 01: high-level active 11: rising-edge The lower bit is read-only and is always 1. |
| config_61 | 27:26 | rw | 0x1 | Configuration for interrupt ID#61 01: high-level active 11: rising-edge The lower bit is read-only and is always 1. |
| config_60 | 25:24 | rw | 0x1 | Configuration for interrupt ID#60 01: high-level active 11: rising-edge The lower bit is read-only and is always 1. |
| config_59 | 23:22 | rw | 0x1 | Configuration for interrupt ID#59 01: high-level active 11: rising-edge The lower bit is read-only and is always 1. |
| config_58 | 21:20 | rw | 0x1 | Configuration for interrupt ID#58 01: high-level active 11: rising-edge The lower bit is read-only and is always 1. |
| config_57 | 19:18 | rw | 0x1 | Configuration for interrupt ID#57 01: high-level active 11: rising-edge The lower bit is read-only and is always 1. |
| config_56 | 17:16 | rw | 0x1 | Configuration for interrupt ID#56 01: high-level active 11: rising-edge The lower bit is read-only and is always 1. |
| config_55 | 15:14 | rw | 0x1 | Configuration for interrupt ID#55 01: high-level active 11: rising-edge The lower bit is read-only and is always 1. |
| config_54 | 13:12 | rw | 0x1 | Configuration for interrupt ID#54 01: high-level active 11: rising-edge The lower bit is read-only and is always 1. |

| Field Name | Bits | Type | Reset Value | Description |
|------------|-------|------|-------------|--|
| config_53 | 11:10 | rw | 0x1 | Configuration for interrupt ID#53 01: high-level active 11: rising-edge The lower bit is read-only and is always 1. |
| config_52 | 9:8 | rw | 0x1 | Configuration for interrupt ID#52 01: high-level active 11: rising-edge The lower bit is read-only and is always 1. |
| config_51 | 7:6 | rw | 0x1 | Configuration for interrupt ID#51 01: high-level active 11: rising-edge The lower bit is read-only and is always 1. |
| config_50 | 5:4 | rw | 0x1 | Configuration for interrupt ID#50 01: high-level active 11: rising-edge The lower bit is read-only and is always 1. |
| config_49 | 3:2 | rw | 0x1 | Configuration for interrupt ID#49 01: high-level active 11: rising-edge The lower bit is read-only and is always 1. |
| config_48 | 1:0 | rw | 0x1 | Configuration for interrupt ID#48 01: high-level active 11: rising-edge The lower bit is read-only and is always 1. |

Register ([mpcore](#)) ICDICFR4

| | |
|------------------|------------------------------------|
| Name | ICDICFR4 |
| Relative Address | 0x00001C10 |
| Absolute Address | 0xF8F01C10 |
| Width | 32 bits |
| Access Type | rw |
| Reset Value | 0x55555555 |
| Description | Interrupt Configuration Register 4 |

Register ICDICFR4 Details

The ICDICFR 4 register control the interrupt sensitivity of the Shared Peripheral Interrupts (SPI), IRQ ID #64 to ID #79. This register has two bits per interrupt. This two bit field is either equal to 01 (high-level active) or equal to 11 (rising-edge sensitive). The LSB is always 1 because only one CPU will handle a SPI interrupt, regardless of the number of CPUs targeted.

Refer to UG585 TRM Section 7.2.3 Shared Peripheral Interrupts (SPI) for the required sensitivity type for the SPI interrupts. The SPI interrupts must match the expected sensitivity. Interrupts from the PL

may be high-level or rising edge sensitive; this must be coordinated with the PL hardware and software.

| Field Name | Bits | Type | Reset Value | Description |
|------------|-------|------|-------------|--|
| config_79 | 31:30 | rw | 0x1 | Configuration for interrupt ID#79 01: high-level active 11: rising-edge The lower bit is read-only and is always 1. |
| config_78 | 29:28 | rw | 0x1 | Configuration for interrupt ID#78 01: high-level active 11: rising-edge The lower bit is read-only and is always 1. |
| config_77 | 27:26 | rw | 0x1 | Configuration for interrupt ID#77 01: high-level active 11: rising-edge The lower bit is read-only and is always 1. |
| config_76 | 25:24 | rw | 0x1 | Configuration for interrupt ID#76 01: high-level active 11: rising-edge The lower bit is read-only and is always 1. |
| config_75 | 23:22 | rw | 0x1 | Configuration for interrupt ID#75 01: high-level active 11: rising-edge The lower bit is read-only and is always 1. |
| config_74 | 21:20 | rw | 0x1 | Configuration for interrupt ID#74 01: high-level active 11: rising-edge The lower bit is read-only and is always 1. |
| config_73 | 19:18 | rw | 0x1 | Configuration for interrupt ID#73 01: high-level active 11: rising-edge The lower bit is read-only and is always 1. |
| config_72 | 17:16 | rw | 0x1 | Configuration for interrupt ID#72 01: high-level active 11: rising-edge The lower bit is read-only and is always 1. |
| config_71 | 15:14 | rw | 0x1 | Configuration for interrupt ID#71 01: high-level active 11: rising-edge The lower bit is read-only and is always 1. |
| config_70 | 13:12 | rw | 0x1 | Configuration for interrupt ID#70 01: high-level active 11: rising-edge The lower bit is read-only and is always 1. |

| Field Name | Bits | Type | Reset Value | Description |
|------------|-------|------|-------------|--|
| config_69 | 11:10 | rw | 0x1 | Configuration for interrupt ID#69 01: high-level active 11: rising-edge The lower bit is read-only and is always 1. |
| config_68 | 9:8 | rw | 0x1 | Configuration for interrupt ID#68 01: high-level active 11: rising-edge The lower bit is read-only and is always 1. |
| config_67 | 7:6 | rw | 0x1 | Configuration for interrupt ID#67 01: high-level active 11: rising-edge The lower bit is read-only and is always 1. |
| config_66 | 5:4 | rw | 0x1 | Configuration for interrupt ID#66 01: high-level active 11: rising-edge The lower bit is read-only and is always 1. |
| config_65 | 3:2 | rw | 0x1 | Configuration for interrupt ID#65 01: high-level active 11: rising-edge The lower bit is read-only and is always 1. |
| config_64 | 1:0 | rw | 0x1 | Configuration for interrupt ID#64 01: high-level active 11: rising-edge The lower bit is read-only and is always 1. |

Register ([mpcore](#)) ICDICFR5

| | |
|------------------|------------------------------------|
| Name | ICDICFR5 |
| Relative Address | 0x00001C14 |
| Absolute Address | 0xF8F01C14 |
| Width | 32 bits |
| Access Type | rw |
| Reset Value | 0x55555555 |
| Description | Interrupt Configuration Register 5 |

Register ICDICFR5 Details

The ICDICFR 5 register control the interrupt sensitivity of the Shared Peripheral Interrupts (SPI), IRQ ID #80 to ID #95 (reserved: 93, 94, 95). This register has two bits per interrupt. This two bit field is either equal to 01 (high-level active) or equal to 11 (rising-edge sensitive). The LSB is always 1 because only one CPU will handle a SPI interrupt, regardless of the number of CPUs targeted.

Refer to UG585 TRM Section 7.2.3 Shared Peripheral Interrupts (SPI) for the required sensitivity type for the SPI interrupts. The SPI interrupts must match the expected sensitivity. Interrupts from the PL

may be high-level or rising edge sensitive; this must be coordinated with the PL hardware and software.

| Field Name | Bits | Type | Reset Value | Description |
|------------|-------|------|-------------|--|
| config_95 | 31:30 | rw | 0x1 | Configuration for interrupt ID#95 01: high-level active 11: rising-edge The lower bit is read-only and is always 1. |
| config_94 | 29:28 | rw | 0x1 | Configuration for interrupt ID#94 01: high-level active 11: rising-edge The lower bit is read-only and is always 1. |
| config_93 | 27:26 | rw | 0x1 | Configuration for interrupt ID#93 01: high-level active 11: rising-edge The lower bit is read-only and is always 1. |
| config_92 | 25:24 | rw | 0x1 | Configuration for interrupt ID#92 01: high-level active 11: rising-edge The lower bit is read-only and is always 1. |
| config_91 | 23:22 | rw | 0x1 | Configuration for interrupt ID#91 01: high-level active 11: rising-edge The lower bit is read-only and is always 1. |
| config_90 | 21:20 | rw | 0x1 | Configuration for interrupt ID#90 01: high-level active 11: rising-edge The lower bit is read-only and is always 1. |
| config_89 | 19:18 | rw | 0x1 | Configuration for interrupt ID#89 01: high-level active 11: rising-edge The lower bit is read-only and is always 1. |
| config_88 | 17:16 | rw | 0x1 | Configuration for interrupt ID#88 01: high-level active 11: rising-edge The lower bit is read-only and is always 1. |
| config_87 | 15:14 | rw | 0x1 | Configuration for interrupt ID#87 01: high-level active 11: rising-edge The lower bit is read-only and is always 1. |
| config_86 | 13:12 | rw | 0x1 | Configuration for interrupt ID#86 01: high-level active 11: rising-edge The lower bit is read-only and is always 1. |

| Field Name | Bits | Type | Reset Value | Description |
|------------|-------|------|-------------|--|
| config_85 | 11:10 | rw | 0x1 | Configuration for interrupt ID#85 01: high-level active 11: rising-edge The lower bit is read-only and is always 1. |
| config_84 | 9:8 | rw | 0x1 | Configuration for interrupt ID#84 01: high-level active 11: rising-edge The lower bit is read-only and is always 1. |
| config_83 | 7:6 | rw | 0x1 | Configuration for interrupt ID#83 01: high-level active 11: rising-edge The lower bit is read-only and is always 1. |
| config_82 | 5:4 | rw | 0x1 | Configuration for interrupt ID#82 01: high-level active 11: rising-edge The lower bit is read-only and is always 1. |
| config_81 | 3:2 | rw | 0x1 | Configuration for interrupt ID#81 01: high-level active 11: rising-edge The lower bit is read-only and is always 1. |
| config_80 | 1:0 | rw | 0x1 | Configuration for interrupt ID#80 01: high-level active 11: rising-edge The lower bit is read-only and is always 1. |

Register ([mpcore](#)) ppi_status

| | |
|------------------|---------------------|
| Name | ppi_status |
| Relative Address | 0x00001D00 |
| Absolute Address | 0xF8F01D00 |
| Width | 32 bits |
| Access Type | ro |
| Reset Value | 0x00000000 |
| Description | PPI Status Register |

Register ppi_status Details

| Field Name | Bits | Type | Reset Value | Description |
|------------|-------|------|-------------|--|
| reserved | 31:16 | ro | 0x0 | Reserved. Writes are ignored, read data is always zero |
| ppi_status | 15:11 | ro | 0x0 | Returns the status of the PPI(4:0) inputs on the distributor: * PPI[4] is nIRQ * PPI[3] is the private watchdog * PPI[2] is the private timer * PPI[1] is nFIQ * PPI[0] is the global timer. PPI[1] and PPI[4] are active LOW PPI[0], PPI[2] and PPI[3] are active HIGH. Note These bits return the actual status of the PPI(4:0) signals. The ICDISPRn and ICDICPRn registers can also provide the PPI(4:0) status but because you can write to these registers then they might not contain the actual status of the PPI(4:0) signals. |
| SBZ | 10:0 | ro | 0x0 | SBZ |

Register ([mpcore](#)) spi_status_0

| | |
|------------------|-----------------------|
| Name | spi_status_0 |
| Relative Address | 0x00001D04 |
| Absolute Address | 0xF8F01D04 |
| Width | 32 bits |
| Access Type | ro |
| Reset Value | 0x00000000 |
| Description | SPI Status Register 0 |

Register spi_status_0 Details

| Field Name | Bits | Type | Reset Value | Description |
|------------|------|------|-------------|---|
| spi_status | 31:0 | ro | 0x0 | Returns the status of the IRQ ID32 to ID63 inputs on the distributor. These bits return the actual status of the IRQ signals. Note: The ICDISPR1 and ICDICPR1 registers can also provide the IRQ status but because you can write to these registers then they might not contain the actual status of the IRQ signals. |

Register ([mpcore](#)) spi_status_1

| | |
|------------------|-----------------------|
| Name | spi_status_1 |
| Relative Address | 0x00001D08 |
| Absolute Address | 0xF8F01D08 |
| Width | 32 bits |
| Access Type | ro |
| Reset Value | 0x00000000 |
| Description | SPI Status Register 1 |

Register spi_status_1 Details

| Field Name | Bits | Type | Reset Value | Description |
|------------|------|------|-------------|---|
| spi_status | 31:0 | ro | 0x0 | Returns the status of the IRQ ID64 to ID95 inputs on the distributor. These bits return the actual status of the IRQ signals. Note: The ICDISPR2 and ICDICPR2 registers can also provide the IRQ status but because you can write to these registers then they might not contain the actual status of the IRQ signals. |

Register ([mpcore](#)) ICDSGIR

| | |
|------------------|---------------------------------------|
| Name | ICDSGIR |
| Relative Address | 0x00001F00 |
| Absolute Address | 0xF8F01F00 |
| Width | 32 bits |
| Access Type | rw |
| Reset Value | 0x00000000 |
| Description | Software Generated Interrupt Register |

Register ICDSGIR Details

| Field Name | Bits | Type | Reset Value | Description |
|------------------|-------|------|-------------|---|
| reserved | 31:26 | rw | 0x0 | reserved |
| TargetListFilter | 25:24 | rw | 0x0 | 0b00: send the interrupt to the CPU interfaces specified in the CPUTargetList field 0b01: send the interrupt to all CPU interfaces except the CPU interface that requested the interrupt 0b10: send the interrupt on only to the CPU interface that requested the interrupt 0b11: reserved |

| Field Name | Bits | Type | Reset Value | Description |
|---------------|-------|------|-------------|---|
| CPUTargetList | 23:16 | rw | 0x0 | When TargetListFilter is 0b00, defines the CPU interfaces the Distributor must send the interrupt to. Each bit refers to the corresponding CPU interface. |
| SATT | 15 | rw | 0x0 | Determines the condition for sending the SGI specified in the SGIINTID field to a specified CPU interfaces: 0: only if the SGI is configured as Secure on that interface. 1: only if the SGI is configured as Non-secure on that interface. |
| SBZ | 14:4 | rw | 0x0 | SBZ |
| SGIINTID | 3:0 | rw | 0x0 | The Interrupt ID of the SGI to send to the specified CPU interfaces. |

Register ([mpcore](#)) ICPIDR4

| | |
|------------------|----------------|
| Name | ICPIDR4 |
| Relative Address | 0x00001FD0 |
| Absolute Address | 0xF8F01FD0 |
| Width | 32 bits |
| Access Type | rw |
| Reset Value | 0x00000004 |
| Description | Peripheral ID4 |

Register ICPIDR4 Details

| Field Name | Bits | Type | Reset Value | Description |
|------------------|------|------|-------------|------------------------------------|
| reserved | 31:4 | rw | 0x0 | reserved |
| ContinuationCode | 3:0 | rw | 0x4 | Arm-defined ContinuationCode field |

Register ([mpcore](#)) ICPIDR5

| | |
|------------------|----------------|
| Name | ICPIDR5 |
| Relative Address | 0x00001FD4 |
| Absolute Address | 0xF8F01FD4 |
| Width | 32 bits |
| Access Type | rw |
| Reset Value | 0x00000000 |
| Description | Peripheral ID5 |

Register ICPIDR5 Details

| Field Name | Bits | Type | Reset Value | Description |
|------------|------|------|-------------|-------------|
| reserved | 31:0 | rw | 0x0 | Reserved |

Register ([mpcore](#)) ICPIDR6

| | |
|------------------|----------------|
| Name | ICPIDR6 |
| Relative Address | 0x00001FD8 |
| Absolute Address | 0xF8F01FD8 |
| Width | 32 bits |
| Access Type | rw |
| Reset Value | 0x00000000 |
| Description | Peripheral ID6 |

Register ICPIDR6 Details

| Field Name | Bits | Type | Reset Value | Description |
|------------|------|------|-------------|-------------|
| reserved | 31:0 | rw | 0x0 | Reserved |

Register ([mpcore](#)) ICPIDR7

| | |
|------------------|----------------|
| Name | ICPIDR7 |
| Relative Address | 0x00001FDC |
| Absolute Address | 0xF8F01FDC |
| Width | 32 bits |
| Access Type | rw |
| Reset Value | 0x00000000 |
| Description | Peripheral ID7 |

Register ICPIDR7 Details

| Field Name | Bits | Type | Reset Value | Description |
|------------|------|------|-------------|-------------|
| reserved | 31:0 | rw | 0x0 | Reserved |

Register ([mpcore](#)) ICPIDR0

| | |
|------------------|------------|
| Name | ICPIDR0 |
| Relative Address | 0x00001FE0 |

Absolute Address 0xF8F01FE0
 Width 32 bits
 Access Type rw
 Reset Value 0x00000090
 Description Peripheral ID0

Register ICPIDR0 Details

| Field Name | Bits | Type | Reset Value | Description |
|------------|------|------|-------------|------------------------------|
| reserved | 31:8 | rw | 0x0 | reserved |
| DevID_low | 7:0 | rw | 0x90 | Arm-defined DevID[7:0] field |

Register ([mpcore](#)) ICPIDR1

Name ICPIDR1
 Relative Address 0x00001FE4
 Absolute Address 0xF8F01FE4
 Width 32 bits
 Access Type rw
 Reset Value 0x000000B3
 Description Peripheral ID1

Register ICPIDR1 Details

| Field Name | Bits | Type | Reset Value | Description |
|------------|------|------|-------------|-------------------------------|
| reserved | 31:8 | rw | 0x0 | reserved |
| ARchID_low | 7:4 | rw | 0xB | Arm-defined ArchID[3:0] field |
| DevID_high | 3:0 | rw | 0x3 | Arm-defined DevID[11:8] field |

Register ([mpcore](#)) ICPIDR2

Name ICPIDR2
 Relative Address 0x00001FE8
 Absolute Address 0xF8F01FE8
 Width 32 bits
 Access Type rw
 Reset Value 0x0000001B
 Description Peripheral ID2

Register ICPIDR2 Details

| Field Name | Bits | Type | Reset Value | Description |
|-------------|------|------|-------------|------------------------------------|
| reserved | 31:8 | rw | 0x0 | reserved |
| ArchRev | 7:4 | rw | 0x1 | Arm-defined ArchRev field |
| UsesJEPcode | 3 | rw | 0x1 | Arm-defined ContinuationCode field |
| ArchID_high | 2:0 | rw | 0x3 | Arm-defined ArchID[6:4] field |

Register ([mpcore](#)) ICPIDR3

| | |
|------------------|----------------|
| Name | ICPIDR3 |
| Relative Address | 0x00001FEC |
| Absolute Address | 0xF8F01FEC |
| Width | 32 bits |
| Access Type | rw |
| Reset Value | 0x00000000 |
| Description | Peripheral ID3 |

Register ICPIDR3 Details

| Field Name | Bits | Type | Reset Value | Description |
|------------|------|------|-------------|----------------------------|
| reserved | 31:8 | rw | 0x0 | reserved |
| Revision | 7:4 | rw | 0x0 | Arm-defined Revision field |
| reserved | 3:0 | rw | 0x0 | reserved |

Register ([mpcore](#)) ICCIDR0

| | |
|------------------|---------------|
| Name | ICCIDR0 |
| Relative Address | 0x00001FF0 |
| Absolute Address | 0xF8F01FF0 |
| Width | 32 bits |
| Access Type | rw |
| Reset Value | 0x0000000D |
| Description | Component ID0 |

Register ICCIDR0 Details

| Field Name | Bits | Type | Reset Value | Description |
|------------|------|------|-------------|---|
| | 31:0 | rw | 0xD | Arm-defined fixed values for the preamble for component discovery |

Register ([mpcore](#)) ICCIDR1

| | |
|------------------|---------------|
| Name | ICCIDR1 |
| Relative Address | 0x00001FF4 |
| Absolute Address | 0xF8F01FF4 |
| Width | 32 bits |
| Access Type | rw |
| Reset Value | 0x000000F0 |
| Description | Component ID1 |

Register ICCIDR1 Details

| Field Name | Bits | Type | Reset Value | Description |
|------------|------|------|-------------|---|
| | 31:0 | rw | 0xF0 | Arm-defined fixed values for the preamble for component discovery |

Register ([mpcore](#)) ICCIDR2

| | |
|------------------|---------------|
| Name | ICCIDR2 |
| Relative Address | 0x00001FF8 |
| Absolute Address | 0xF8F01FF8 |
| Width | 32 bits |
| Access Type | rw |
| Reset Value | 0x00000005 |
| Description | Component ID2 |

Register ICCIDR2 Details

| Field Name | Bits | Type | Reset Value | Description |
|------------|------|------|-------------|---|
| | 31:0 | rw | 0x5 | Arm-defined fixed values for the preamble for component discovery |

Register ([mpcore](#)) ICCIDR3

| | |
|------------------|---------------|
| Name | ICCIDR3 |
| Relative Address | 0x00001FFC |
| Absolute Address | 0xF8F01FFC |
| Width | 32 bits |
| Access Type | rw |
| Reset Value | 0x000000B1 |
| Description | Component ID3 |

Register ICCIDR3 Details

| Field Name | Bits | Type | Reset Value | Description |
|------------|------|------|-------------|---|
| | 31:0 | rw | 0xB1 | Arm-defined fixed values for the preamble for component discovery |

B.25 On-Chip Memory (ocm)

| | |
|--------------|--------------------------|
| Module Name | On-Chip Memory (ocm) |
| Base Address | 0xF800C000 ocm |
| Description | On-Chip Memory Registers |
| Vendor Info | Xilinx |

Register Summary

| Register Name | Address | Width | Type | Reset Value | Description |
|---------------------------------------|------------|-------|-------|-------------|--|
| OCM_PARITY_CTRL | 0x00000000 | 32 | mixed | 0x00000000 | Control fields for RAM parity operation |
| OCM_PARITY_ERRADDRESS | 0x00000004 | 32 | mixed | 0x00000000 | Stores the first parity error access address. This register is sticky and will retain its value unless explicitly cleared (written with 1's) with an APB write access. The physical RAM address is logged. |
| OCM_IRQ_STS | 0x00000008 | 32 | mixed | 0x00000000 | Status of OCM Interrupt |
| OCM_CONTROL | 0x0000000C | 32 | mixed | 0x00000000 | Control fields for OCM |

Register ([ocm](#)) OCM_PARITY_CTRL

| | |
|------------------|---|
| Name | OCM_PARITY_CTRL |
| Relative Address | 0x00000000 |
| Absolute Address | 0xF800C000 |
| Width | 32 bits |
| Access Type | mixed |
| Reset Value | 0x00000000 |
| Description | Control fields for RAM parity operation |

Register OCM_PARITY_CTRL Details

| Field Name | Bits | Type | Reset Value | Description |
|------------------------|-------|------|-------------|--|
| reserved | 31:21 | ro | 0x0 | Returns 0 when read |
| OddParityEn | 20:5 | rw | 0x0 | Enable RAM Odd Parity Generation. The default computed parity is even but this can be changed to odd parity via this APB register field. Note that, on reads, parity is always computed as even parity. The odd parity generation option is useful for verification purposes, enabling parity errors to be injected. One control bit per data byte (OddParity[0] controls Data[7:0] e.t.c) 0: Even Parity generated 1: Odd Parity generated |
| LockFailErrIrqEn | 4 | rw | 0x0 | Enable interrupt when an AXI LOCK ("locked access") command is detected. |
| MultipleParityErrIrqEn | 3 | rw | 0x0 | Same as SingleParityErrIrqEn, but enables IRQ on multiple parity errors detected. 0: IRQ is not generated when parity error detected and ParityCheckDis=0 1: IRQ is generated when parity error detected and ParityCheckDis=0. |
| SingleParityErrIrqEn | 2 | rw | 0x0 | Enable interrupt when a single parity error is detected. Note that even if this field is 0, the OCM_IRQ_STS register will still log the error if ParityCheckDis=0. This allows software the option of polling if an error occurred. 0: IRQ is not generated when parity error detected and ParityCheckDis=0 1: IRQ is generated when parity error detected and ParityCheckDis=0. |
| RdRespParityErrEn | 1 | rw | 0x0 | Enable AXI read 'SLVERR' response for parity error detection. 0: Error will not be sent on AXI read channel when parity error detected 1: Error will be sent on AXI read channel when parity error detected and ParityCheckDis=0 |
| ParityCheckDis | 0 | rw | 0x0 | Disable RAM Parity Checking. No checking or logging of status will occur when 1. 0: RAM Parity checking is enabled 1: RAM Parity checking is disabled |

Register (ocm) OCM_PARITY_ERRADDRESS

Name OCM_PARITY_ERRADDRESS
Relative Address 0x00000004

| | |
|------------------|--|
| Absolute Address | 0xF800C004 |
| Width | 32 bits |
| Access Type | mixed |
| Reset Value | 0x00000000 |
| Description | Stores the first parity error access address. This register is sticky and will retain its value unless explicitly cleared (written with 1's) with an APB write access. The physical RAM address is logged. |

Register OCM_PARITY_ERRADDRESS Details

| Field Name | Bits | Type | Reset Value | Description |
|------------------|-------|------|-------------|---|
| reserved | 31:14 | ro | 0x0 | Return 0 when read |
| ParityErrAddress | 13:0 | wtc | 0x0 | When a parity Error occurs, the access address associated with the error is logged here. The first error address will be held if multiple parity errors occur. Need an explicit write of all '1's' to reset/clear this field. |

Register ([ocm](#)) OCM_IRQ_STS

| | |
|------------------|-------------------------|
| Name | OCM_IRQ_STS |
| Relative Address | 0x00000008 |
| Absolute Address | 0xF800C008 |
| Width | 32 bits |
| Access Type | mixed |
| Reset Value | 0x00000000 |
| Description | Status of OCM Interrupt |

Register OCM_IRQ_STS Details

| Field Name | Bits | Type | Reset Value | Description |
|-------------|------|------|-------------|---|
| reserved | 31:3 | ro | 0x0 | Return 0 when read |
| LockFailErr | 2 | wtc | 0x0 | When set (1), indicates that an AXI LOCK has been attempted (not supported by OCM). This is a sticky bit. Once set it can only be cleared by explicitly writing a 1 to this field. This field drives the interrupt pin. (Associated irq enable bit must be set) |

| Field Name | Bits | Type | Reset Value | Description |
|-------------------|------|------|-------------|--|
| MultipleParityErr | 1 | wtc | 0x0 | Status of OCM multiple parity error. This is a sticky bit. Once set it can only be cleared by explicitly writing a 1 to this field. This field drives the interrupt pin. (Associated irq enable bit must be set) 0: Multiple OCM parity Errors have not occurred 1: Multiple OCM parity Errors have occurred |
| SingleParityErr | 0 | wtc | 0x0 | Status of OCM single parity error. This is a sticky bit. Once set it can only be cleared by explicitly writing a 1 to this field. This field drives the interrupt pin (Associated irq enable bit must be set) 0: Single OCM parity Error has not occurred 1: Single OCM parity Error has occurred |

Register ([ocm](#)) OCM_CONTROL

| | |
|------------------|------------------------|
| Name | OCM_CONTROL |
| Relative Address | 0x0000000C |
| Absolute Address | 0xF800C00C |
| Width | 32 bits |
| Access Type | mixed |
| Reset Value | 0x00000000 |
| Description | Control fields for OCM |

Register OCM_CONTROL Details

| Field Name | Bits | Type | Reset Value | Description |
|-----------------------|------|------|-------------|---|
| reserved | 31:3 | ro | 0x0 | Return 0 when read |
| ArbShareTopSwScuWrDls | 2 | rw | 0x0 | Controls the arbitration to memory between the topswitch port and the scuwr port. 0: The topsw and the scuWr port share the memory bandwidth - 50% each. 1: The scuWr takes higher priority over the topswitch port (unless the ScuWrPriorityLo bit is set) |
| reserved | 1 | rw | 0x0 | Reserved. Do not modify. |
| ScuWrPriorityLo | 0 | rw | 0x0 | When set (1), changes the priority of the SCU write port to LOW from Medium |

B.26 Quad-SPI Flash Controller (qspi)

| | |
|---------------|----------------------------------|
| Module Name | Quad-SPI Flash Controller (qspi) |
| Software Name | XQSPIPS |
| Base Address | 0xE000D000 qspi |
| Description | LQSPI module Registers |
| Vendor Info | Xilinx lqspi |

Register Summary

| Register Name | Address | Width | Type | Reset Value | Description |
|---------------------------------------|------------|-------|-------|-------------|--|
| XQSPIPS_CR_OFFSET | 0x00000000 | 32 | mixed | 0x80020000 | QSPI configuration register |
| XQSPIPS_SR_OFFSET | 0x00000004 | 32 | mixed | 0x00000004 | QSPI interrupt status register |
| XQSPIPS_IER_OFFSET | 0x00000008 | 32 | mixed | 0x00000000 | Interrupt Enable register. |
| XQSPIPS_IDR_OFFSET | 0x0000000C | 32 | mixed | 0x00000000 | Interrupt disable register. |
| XQSPIPS_IMR_OFFSET | 0x00000010 | 32 | ro | 0x00000000 | Interrupt mask register |
| XQSPIPS_ER_OFFSET | 0x00000014 | 32 | mixed | 0x00000000 | SPI_Enable Register |
| XQSPIPS_DR_OFFSET | 0x00000018 | 32 | rw | 0x00000000 | Delay Register |
| XQSPIPS_TXD_00_OFFSET | 0x0000001C | 32 | wo | 0x00000000 | Transmit Data Register. Keyhole addresses for the Transmit data FIFO. See also TXD1-3. |
| XQSPIPS_RXD_OFFSET | 0x00000020 | 32 | ro | 0x00000000 | Receive Data Register |
| XQSPIPS_SICR_OFFSET | 0x00000024 | 32 | mixed | 0x000000FF | Slave Idle Count Register |
| XQSPIPS_TXWR_OFFSET | 0x00000028 | 32 | rw | 0x00000001 | TX_FIFO Threshold Register |
| RX_thres_REG | 0x0000002C | 32 | rw | 0x00000001 | RX FIFO Threshold Register |
| GPIO | 0x00000030 | 32 | rw | 0x00000001 | General Purpose Inputs and Outputs Register for the Quad-SPI Controller core |
| LPBK_DLY_ADJ | 0x00000038 | 32 | rw | 0x0000002D | Loopback Master Clock Delay Adjustment Register |
| XQSPIPS_TXD_01_OFFSET | 0x00000080 | 32 | wo | 0x00000000 | Transmit Data Register. Keyhole addresses for the Transmit data FIFO. |
| XQSPIPS_TXD_10_OFFSET | 0x00000084 | 32 | wo | 0x00000000 | Transmit Data Register. Keyhole addresses for the Transmit data FIFO. |
| XQSPIPS_TXD_11_OFFSET | 0x00000088 | 32 | wo | 0x00000000 | Transmit Data Register. Keyhole addresses for the Transmit data FIFO. |

| Register Name | Address | Width | Type | Reset Value | Description |
|--|------------|-------|------|-------------|--|
| XQSPIPS_LQSPI_CR_OF_FSET | 0x000000A0 | 32 | rw | x | Configuration Register specifically for the Linear Quad-SPI Controller |
| XQSPIPS_LQSPI_SR_OF_FSET | 0x000000A4 | 9 | rw | 0x00000000 | Status Register specifically for the Linear Quad-SPI Controller |
| MOD_ID | 0x000000FC | 32 | rw | 0x01090101 | Module Identification register |

Register ([qspi](#)) XQSPIPS_CR_OFFSET

| | |
|------------------|-----------------------------|
| Name | XQSPIPS_CR_OFFSET |
| Software Name | CR |
| Relative Address | 0x00000000 |
| Absolute Address | 0xE000D000 |
| Width | 32 bits |
| Access Type | mixed |
| Reset Value | 0x80020000 |
| Description | QSPI configuration register |

Register XQSPIPS_CR_OFFSET Details

| Field Name | Bits | Type | Reset Value | Description |
|---------------------------------|-------|------|-------------|---|
| XQSPIPS_CR_IFMODE_MASK (IFMODE) | 31 | rw | 0x1 | Flash memory interface mode control: 0: legacy SPI mode 1: Flash memory interface mode This control is required to enable or disable automatic recognition of instruction bytes in the first byte of a transfer. If this mode is disabled, the core will operate in standard SPI mode, with no dual- or quad-bit input or output capability; the extended bits will be configured as inputs to prevent any driver contention on these pins. If enabled, flash memory interface instructions are automatically recognized and the I/O configured accordingly. |
| reserved | 30:27 | ro | 0x0 | Reserved, read as zero, ignored on write. |
| XQSPIPS_CR_ENDIAN_MASK (ENDIAN) | 26 | rw | 0x0 | 0 for little endian format when writing to the transmit data register 0x1C or reading from the receive data register 0x20. 1 for big endian format when writing to the transmit data register 0x1C or reading from the receive data register 0x20. |
| reserved | 25:20 | ro | 0x0 | Reserved, read as zero, ignored on write. |

| Field Name | Bits | Type | Reset Value | Description |
|---|-------|------|-------------|---|
| Holdb_dr | 19 | rw | 0x0 | If set, Holdb and WPn pins are actively driven by the qspi controller in 1-bit and 2-bit modes . If not set, then external pull up is required on HOLDb and WPn pins . Note that this bit doesn't affect the quad(4-bit) mode as Controller always drives these pins in quad mode. It is highly recommended to set this bit always(irrespective of mode of operation) while using QSPI |
| reserved | 18 | rw | 0x0 | Reserved |
| reserved | 17 | rw | 0x1 | Reserved |
| XQSPIPS_CR_MANSTRT_MASK (MANSTRT) | 16 | wo | 0x0 | Manual Start Command 1: start transmission of data 0: don't care |
| XQSPIPS_CR_MANSTRT_EN_MASK (MANSTRTEN) | 15 | rw | 0x0 | Manual Start Enable 1: enables manual start 0: auto mode |
| XQSPIPS_CR_SSFORCE_MASK (SSFORCE) | 14 | rw | 0x0 | Manual CS 1: manual CS mode 0: auto mode |
| reserved | 13:11 | rw | 0x0 | Reserved |
| PCS | 10 | rw | 0x0 | Peripheral chip select line, directly drive n_ss_out if Manual_C is set |
| reserved | 9 | rw | 0x0 | Reserved |
| REF_CLK | 8 | rw | 0x0 | Reserved. Must be 0 |
| FIFO_WIDTH | 7:6 | rw | 0x0 | FIFO width Must be set to 2'b11 (32bits). All other settings are not supported. |
| BAUD_RATE_DIV | 5:3 | rw | 0x0 | Master mode baud rate divisor 000: divide by 2. This is the only baud rate setting that can be used if the loopback clock is enabled (USE_LPBK). This setting also works in non-loopback mode. 001: divide by 4 010: divide by 8 011: divide by 16 100: divide by 32 101: divide by 64 110: divide by 128 111: divide by 256 |
| XQSPIPS_CR_CPHA_MASK (CPHA) | 2 | rw | 0x0 | Clock phase 1: the QSPI clock is inactive outside the word 0: the QSPI clock is active outside the word Note : For {CLK_PH, CLK_POL}, only 2'b11 and 2'b00 are supported. |

| Field Name | Bits | Type | Reset Value | Description |
|------------------------------------|------|------|-------------|--|
| XQSPIPS_CR_CPOL_MASK (CPOL) | 1 | rw | 0x0 | Clock polarity outside QSPI word 1: The QSPI clock is quiescent high 0: The QSPI clock is quiescent low Note : For {CLK_PH, CLK_POL}, only 2'b11 and 2'b00 are supported. |
| XQSPIPS_CR_MSTREN_MASK (MSTREN) | 0 | rw | 0x0 | Mode select 1: The QSPI is in master mode 0: RESERVED In QSPI boot mode, ROM code will set this bit. In other boot modes, this bit must be set before using QSPI. |

Register ([qspi](#)) XQSPIPS_SR_OFFSET

| | |
|------------------|--------------------------------|
| Name | XQSPIPS_SR_OFFSET |
| Software Name | SR |
| Relative Address | 0x00000004 |
| Absolute Address | 0xE000D004 |
| Width | 32 bits |
| Access Type | mixed |
| Reset Value | 0x00000004 |
| Description | QSPI interrupt status register |

Register XQSPIPS_SR_OFFSET Details

This register is set when the described event occurs. Interrupt mask value does not affect interrupt status register. Mask value is only used to mask interrupt output.

Bit 0 and 6 are write to clear. All other bits are read only.

| Field Name | Bits | Type | Reset Value | Description |
|---|------|------|-------------|---|
| reserved | 31:7 | ro | 0x0 | Reserved, read as zero, ignored on write. |
| XQSPIPS_IXR_TXUF_MASK (IXR_TXUF) | 6 | wtc | 0x0 | TX FIFO underflow, write one to this bit location to clear. 1: underflow is detected 0: no underflow has been detected Write 1 to this bit location to clear |
| XQSPIPS_IXR_RXFULL_MASK (IXR_RXFULL) | 5 | ro | 0x0 | RX FIFO full (current FIFO status) 1: FIFO is full 0: FIFO is not full |

| Field Name | Bits | Type | Reset Value | Description |
|---|------|------|-------------|--|
| XQSPIPS_IXR_RXNEMPTY_MASK (IXR_RXNEMPTY) | 4 | ro | 0x0 | RX FIFO not empty (current FIFO status) 1: FIFO has more than or equal to THRESHOLD entries 0: FIFO has less than RX THRESHOLD entries |
| XQSPIPS_IXR_TXFULL_MASK (IXR_TXFULL) | 3 | ro | 0x0 | TX FIFO full (current FIFO status) 1: FIFO is full 0: FIFO is not full |
| XQSPIPS_IXR_TXOW_MASK (IXR_TXOW) | 2 | ro | 0x1 | TX FIFO not full (current FIFO status) 1: FIFO has less than THRESHOLD entries 0: FIFO has more than or equal to THRESHOLD entries |
| reserved | 1 | ro | 0x0 | Reserved, read as zero, ignored on write. |
| XQSPIPS_IXR_RXOVR_MASK (IXR_RXOVR) | 0 | wtc | 0x0 | Receive Overflow interrupt, write one to this bit location to clear. 1: overflow occurred 0: no overflow occurred Write 1 to this bit location to clear |

Register ([qspi](#)) XQSPIPS_IER_OFFSET

| | |
|------------------|----------------------------|
| Name | XQSPIPS_IER_OFFSET |
| Software Name | IER |
| Relative Address | 0x00000008 |
| Absolute Address | 0xE000D008 |
| Width | 32 bits |
| Access Type | mixed |
| Reset Value | 0x00000000 |
| Description | Interrupt Enable register. |

Register XQSPIPS_IER_OFFSET Details

Writing a 1 to this register sets the corresponding bits of the interrupt mask register.

| Field Name | Bits | Type | Reset Value | Description |
|-------------------------------------|------|------|-------------|---|
| reserved | 31:7 | ro | 0x0 | Reserved, read as zero, ignored on write. |
| XQSPIPS_IXR_TXUF_MASK (IXR_TXUF) | 6 | wo | 0x0 | TX FIFO underflow enable 1: enable the interrupt 0: no effect |

| Field Name | Bits | Type | Reset Value | Description |
|---|------|------|-------------|--|
| XQSPIPS_IXR_RXFULL_MASK (IXR_RXFULL) | 5 | wo | 0x0 | RX FIFO full enable 1: enable the interrupt 0: no effect |
| XQSPIPS_IXR_RXNEMPTY_MASK (IXR_RXNEMPTY) | 4 | wo | 0x0 | RX FIFO not empty enable 1: enable the interrupt 0: no effect |
| XQSPIPS_IXR_TXFULL_MASK (IXR_TXFULL) | 3 | wo | 0x0 | TX FIFO full enable 1: enable the interrupt 0: no effect |
| XQSPIPS_IXR_TXOW_MASK (IXR_TXOW) | 2 | wo | 0x0 | TX FIFO not full enable 1: enable the interrupt 0: no effect |
| reserved | 1 | wo | 0x0 | Reserved, read as zero, ignored on write. |
| XQSPIPS_IXR_RXOVR_MASK (IXR_RXOVR) | 0 | wo | 0x0 | Receive Overflow interrupt enable 1: enable the interrupt 0: no effect |

Register ([qspi](#)) XQSPIPS_IDR_OFFSET

| | |
|------------------|-----------------------------|
| Name | XQSPIPS_IDR_OFFSET |
| Software Name | IDR |
| Relative Address | 0x0000000C |
| Absolute Address | 0xE000D00C |
| Width | 32 bits |
| Access Type | mixed |
| Reset Value | 0x00000000 |
| Description | Interrupt disable register. |

Register XQSPIPS_IDR_OFFSET Details

| Field Name | Bits | Type | Reset Value | Description |
|-------------------------------------|------|------|-------------|---|
| reserved | 31:7 | ro | 0x0 | Reserved, read as zero, ignored on write. |
| XQSPIPS_IXR_TXUF_MASK (IXR_TXUF) | 6 | wo | 0x0 | TX FIFO underflow enable 1: disables the interrupt 0: no effect |

| Field Name | Bits | Type | Reset Value | Description |
|---|------|------|-------------|--|
| XQSPIPS_IXR_RXFULL_MASK (IXR_RXFULL) | 5 | wo | 0x0 | RX FIFO full enable 1: disables the interrupt 0: no effect |
| XQSPIPS_IXR_RXNEMPTY_MASK (IXR_RXNEMPTY) | 4 | wo | 0x0 | RX FIFO not empty enable 1: disables the interrupt 0: no effect |
| XQSPIPS_IXR_TXFULL_MASK (IXR_TXFULL) | 3 | wo | 0x0 | TX FIFO full enable 1: disables the interrupt 0: no effect |
| XQSPIPS_IXR_TXOW_MASK (IXR_TXOW) | 2 | wo | 0x0 | TX FIFO not full enable 1: disables the interrupt 0: no effect |
| reserved | 1 | wo | 0x0 | Reserved |
| XQSPIPS_IXR_RXOVR_MASK (IXR_RXOVR) | 0 | wo | 0x0 | Receive Overflow interrupt enable 1: disables the interrupt 0: no effect |

Register ([qspi](#)) XQSPIPS_IMR_OFFSET

| | |
|------------------|-------------------------|
| Name | XQSPIPS_IMR_OFFSET |
| Software Name | IMR |
| Relative Address | 0x00000010 |
| Absolute Address | 0xE000D010 |
| Width | 32 bits |
| Access Type | ro |
| Reset Value | 0x00000000 |
| Description | Interrupt mask register |

Register XQSPIPS_IMR_OFFSET Details

| Field Name | Bits | Type | Reset Value | Description |
|-------------------------------------|------|------|-------------|---|
| reserved | 31:7 | ro | 0x0 | Reserved, read as zero, ignored on write. |
| XQSPIPS_IXR_TXUF_MASK (IXR_TXUF) | 6 | ro | 0x0 | TX FIFO underflow enable 0: interrupt is disabled 1: interrupt is enabled |

| Field Name | Bits | Type | Reset Value | Description |
|---|------|------|-------------|--|
| XQSPIPS_IXR_RXFULL_MASK (IXR_RXFULL) | 5 | ro | 0x0 | RX FIFO full enable 0: interrupt is disabled 1: interrupt is enabled |
| XQSPIPS_IXR_RXNEMPTY_MASK (IXR_RXNEMPTY) | 4 | ro | 0x0 | RX FIFO not empty enable 0: interrupt is disabled 1: interrupt is enabled |
| XQSPIPS_IXR_TXFULL_MASK (IXR_TXFULL) | 3 | ro | 0x0 | TX FIFO full enable 0: interrupt is disabled 1: interrupt is enabled |
| XQSPIPS_IXR_TXOW_MASK (IXR_TXOW) | 2 | ro | 0x0 | TX FIFO not full enable 0: interrupt is disabled 1: interrupt is enabled |
| reserved | 1 | ro | 0x0 | Reserved |
| XQSPIPS_IXR_RXOVR_MASK (IXR_RXOVR) | 0 | ro | 0x0 | Receive Overflow interrupt enable 0: interrupt is disabled 1: interrupt is enabled |

Register ([qspi](#)) XQSPIPS_ER_OFFSET

| | |
|------------------|---------------------|
| Name | XQSPIPS_ER_OFFSET |
| Software Name | ER |
| Relative Address | 0x00000014 |
| Absolute Address | 0xE000D014 |
| Width | 32 bits |
| Access Type | mixed |
| Reset Value | 0x00000000 |
| Description | SPI_Enable Register |

Register XQSPIPS_ER_OFFSET Details

| Field Name | Bits | Type | Reset Value | Description |
|------------------------------------|------|------|-------------|---|
| reserved | 31:1 | ro | 0x0 | Reserved, read as zero, ignored on write. |
| XQSPIPS_ER_ENABLE_MASK (ENABLE) | 0 | rw | 0x0 | SPI_Enable 1: enable the SPI 0: disable the SPI |

Register ([qspi](#)) XQSPIPS_DR_OFFSET

| | |
|------------------|-------------------|
| Name | XQSPIPS_DR_OFFSET |
| Software Name | DR |
| Relative Address | 0x00000018 |
| Absolute Address | 0xE000D018 |
| Width | 32 bits |
| Access Type | rw |
| Reset Value | 0x00000000 |
| Description | Delay Register |

Register XQSPIPS_DR_OFFSET Details

This register is only used in master mode to introduce relative delays into the generation of the master output signals. All timings are defined in cycles of the SPI REFERENCE CLOCK/ext_clk, defined in this table as SPI master ref clock.

| Field Name | Bits | Type | Reset Value | Description |
|--------------------------------------|-------|------|-------------|---|
| d_nss | 31:24 | rw | 0x0 | Delay in SPI REFERENCE CLOCK or ext_clk cycles for the length that the master mode chip select outputs are de-asserted between words when cpha=0. |
| XQSPIPS_DR_BTWN_M ASK (BTWN) | 23:16 | rw | 0x0 | Delay in SPI REFERENCE CLOCK or ext_clk cycles between one chip select being de-activated and the activation of another |
| XQSPIPS_DR_AFTER_M ASK (AFTER) | 15:8 | rw | 0x0 | Delay in SPI REFERENCE CLOCK or ext_clk cycles between last bit of current word and the first bit of the next word. |
| XQSPIPS_DR_INIT_MAS K (INIT) | 7:0 | rw | 0x0 | Added delay in SPI REFERENCE CLOCK or ext_clk cycles between setting n_ss_out low and first bit transfer. |

Register ([qspi](#)) XQSPIPS_TXD_00_OFFSET

| | |
|------------------|--|
| Name | XQSPIPS_TXD_00_OFFSET |
| Software Name | TXD_00 |
| Relative Address | 0x0000001C |
| Absolute Address | 0xE000D01C |
| Width | 32 bits |
| Access Type | wo |
| Reset Value | 0x00000000 |
| Description | Transmit Data Register. Keyhole addresses for the Transmit data FIFO. See also TXD1-3. |

Register XQSPIPS_TXD_00_OFFSET Details

| Field Name | Bits | Type | Reset Value | Description |
|------------|------|------|-------------|--|
| TXD | 31:0 | wo | 0x0 | Data to TX FIFO, for 4-byte instruction for normal read/write data transfer. |

Register ([qspi](#)) XQSPIPS_RXD_OFFSET

| | |
|------------------|-----------------------|
| Name | XQSPIPS_RXD_OFFSET |
| Software Name | RXD |
| Relative Address | 0x00000020 |
| Absolute Address | 0xE000D020 |
| Width | 32 bits |
| Access Type | ro |
| Reset Value | 0x00000000 |
| Description | Receive Data Register |

Register XQSPIPS_RXD_OFFSET Details

| Field Name | Bits | Type | Reset Value | Description |
|--------------|------|------|-------------|-------------------|
| RX_FIFO_data | 31:0 | ro | 0x0 | Data from TX FIFO |

Register ([qspi](#)) XQSPIPS_SICR_OFFSET

| | |
|------------------|---------------------------|
| Name | XQSPIPS_SICR_OFFSET |
| Software Name | SICR |
| Relative Address | 0x00000024 |
| Absolute Address | 0xE000D024 |
| Width | 32 bits |
| Access Type | mixed |
| Reset Value | 0x000000FF |
| Description | Slave Idle Count Register |

Register XQSPIPS_SICR_OFFSET Details

| Field Name | Bits | Type | Reset Value | Description |
|--------------------------|------|------|-------------|---|
| reserved | 31:8 | ro | 0x0 | Reserved, read as zero, ignored on write. |
| XQSPIPS_SICR_MASK (MASK) | 7:0 | rw | 0xFF | SPI in slave mode detects a start only when the external SPI master serial clock (sclk_in) is stable (quiescent state) for SPI REFERENCE CLOCK cycles specified by slave idle count register or when the SPI is deselected. |

Register ([qspi](#)) XQSPIPS_TXWR_OFFSET

| | |
|------------------|----------------------------|
| Name | XQSPIPS_TXWR_OFFSET |
| Software Name | TXWR |
| Relative Address | 0x00000028 |
| Absolute Address | 0xE000D028 |
| Width | 32 bits |
| Access Type | rw |
| Reset Value | 0x00000001 |
| Description | TX_FIFO Threshold Register |

Register XQSPIPS_TXWR_OFFSET Details

| Field Name | Bits | Type | Reset Value | Description |
|----------------------|------|------|-------------|--|
| Threshold_of_TX_FIFO | 31:0 | rw | 0x1 | Defines the level at which the TX FIFO not full interrupt is generated |

Register ([qspi](#)) RX_thres_REG

| | |
|------------------|----------------------------|
| Name | RX_thres_REG |
| Relative Address | 0x0000002C |
| Absolute Address | 0xE000D02C |
| Width | 32 bits |
| Access Type | rw |
| Reset Value | 0x00000001 |
| Description | RX FIFO Threshold Register |

Register RX_thres_REG Details

| Field Name | Bits | Type | Reset Value | Description |
|----------------------|------|------|-------------|---|
| Threshold_of_RX_FIFO | 31:0 | rw | 0x1 | Defines the level at which the RX FIFO not empty interrupt is generated |

Register ([qspi](#)) GPIO

| | |
|------------------|--|
| Name | GPIO |
| Relative Address | 0x00000030 |
| Absolute Address | 0xE000D030 |
| Width | 32 bits |
| Access Type | rw |
| Reset Value | 0x00000001 |
| Description | General Purpose Inputs and Outputs Register for the Quad-SPI Controller core |

Register GPIO Details

| Field Name | Bits | Type | Reset Value | Description |
|------------|------|------|-------------|---|
| reserved | 31:1 | rw | 0x0 | Reserved for future GPIO. |
| WP_N | 0 | rw | 0x1 | Write Protect. Write Protect output for flash devices supporting this function. Active low (may be inverted externally to the core if required for flash devices requiring active high write protect signal.) |

Register ([qspi](#)) LPBK_DLY_ADJ

| | |
|------------------|---|
| Name | LPBK_DLY_ADJ |
| Relative Address | 0x00000038 |
| Absolute Address | 0xE000D038 |
| Width | 32 bits |
| Access Type | rw |
| Reset Value | 0x0000002D |
| Description | Loopback Master Clock Delay Adjustment Register |

Register LPBK_DLY_ADJ Details

Register for enabling the internal loopback for high-speed read data capturing (>40MHz). This feature is only active if bit 5 is set AND if the baud rate divisor is programmed to 2 (i.e., 000).

| Field Name | Bits | Type | Reset Value | Description |
|------------|------|------|-------------|--|
| reserved | 31:6 | rw | 0x0 | Reserved |
| USE_LPBK | 5 | rw | 0x1 | Use internal loopback master clock for read data capturing when baud rate divisor (reg 0x00) is 2 |
| DLY1 | 4:3 | rw | 0x2 | Must be set to 00 if Loopback clock is used. Note: Change this value only when controller is not communicating with the memory device. |
| DLY0 | 2:0 | rw | 0x3 | Must be set to 00 if Loopback clock is used. Note: Change this value only when controller is not communicating with the memory device. |

Register ([qspi](#)) XQSPIPS_TXD_01_OFFSET

| | |
|------------------|---|
| Name | XQSPIPS_TXD_01_OFFSET |
| Software Name | TXD_01 |
| Relative Address | 0x00000080 |
| Absolute Address | 0xE000D080 |
| Width | 32 bits |
| Access Type | wo |
| Reset Value | 0x00000000 |
| Description | Transmit Data Register. Keyhole addresses for the Transmit data FIFO. |

Register XQSPIPS_TXD_01_OFFSET Details

| Field Name | Bits | Type | Reset Value | Description |
|------------|------|------|-------------|---|
| TXD | 31:0 | wo | 0x0 | Data to TX FIFO, for 1-byte instruction, not for normal data transfer. In little endian mode (default), only bits 7:0 are valid, bits 31:8 are ignored. In big endian mode, only the 8 MS bits are valid. |

Register ([qspi](#)) XQSPIPS_TXD_10_OFFSET

| | |
|------------------|---|
| Name | XQSPIPS_TXD_10_OFFSET |
| Software Name | TXD_10 |
| Relative Address | 0x00000084 |
| Absolute Address | 0xE000D084 |
| Width | 32 bits |
| Access Type | wo |
| Reset Value | 0x00000000 |
| Description | Transmit Data Register. Keyhole addresses for the Transmit data FIFO. |

Register XQSPIPS_TXD_10_OFFSET Details

| Field Name | Bits | Type | Reset Value | Description |
|------------|------|------|-------------|--|
| TXD | 31:0 | wo | 0x0 | Data to TX FIFO, for 2-byte instruction, not for normal data transfer. In little endian mode (default), only bits 15:0 are valid, bits 31:16 are ignored. In big endian mode, only the 16 MS bits are valid. |

Register ([qspi](#)) XQSPIPS_TXD_11_OFFSET

| | |
|------------------|---|
| Name | XQSPIPS_TXD_11_OFFSET |
| Software Name | TXD_11 |
| Relative Address | 0x00000088 |
| Absolute Address | 0xE000D088 |
| Width | 32 bits |
| Access Type | wo |
| Reset Value | 0x00000000 |
| Description | Transmit Data Register. Keyhole addresses for the Transmit data FIFO. |

Register XQSPIPS_TXD_11_OFFSET Details

| Field Name | Bits | Type | Reset Value | Description |
|------------|------|------|-------------|--|
| TXD | 31:0 | wo | 0x0 | Data to TX FIFO, for 3-byte instruction, not for normal data transfer. In little endian mode (default), only bits 23:0 are valid, bits 31:24 are ignored. In big endian mode, only the 24 MS bits are valid. |

Register ([qspi](#)) XQSPIPS_LQSPI_CR_OFFSET

| | |
|------------------|--|
| Name | XQSPIPS_LQSPI_CR_OFFSET |
| Software Name | LQSPI_CR |
| Relative Address | 0x000000A0 |
| Absolute Address | 0xE000D0A0 |
| Width | 32 bits |
| Access Type | rw |
| Reset Value | x |
| Description | Configuration Register specifically for the Linear Quad-SPI Controller |

Register XQSPIPS_LQSPI_CR_OFFSET Details

| Field Name | Bits | Type | Reset Value | Description |
|--|------|------|-------------|---|
| XQSPIPS_LQSPI_CR_LINEAR_MASK (LINEAR) | 31 | rw | 0x0 | Linear quad SPI mode, if set, else quad SPI mode |
| XQSPIPS_LQSPI_CR_TWO_MEM_MASK (TWO_MEM) | 30 | rw | 0x0 | Both upper and lower memories are active, if set |
| XQSPIPS_LQSPI_CR_SEP_BUS_MASK (SEP_BUS) | 29 | rw | 0x0 | Separate memory bus, if set. Only has meaning if bit 30 is set |
| XQSPIPS_LQSPI_CR_UPPER_PAGE_MASK (U_PAGE) | 28 | rw | 0x0 | Upper memory page, if set. Only has meaning if bit 30 is set AND bit 29 is clear AND bit 31 is clear. In LQSPI mode, address bit 25 will indicate lower (0) or upper (1) page. In IO mode, this bit is used to select the lower or upper memory for configuration or read/write operations. |
| reserved | 27 | rw | 0x0 | Reserved |
| reserved | 26 | rw | 0x1 | This field should be set to 1'b0. |
| XQSPIPS_LQSPI_CR_MODE_EN_MASK (MODE_EN) | 25 | rw | 0x1 | Enable MODE_BITS[23:16] to be sent, if set. This bit MUST BE SET for dual I/O or quad I/O read (specified through [7:0]). This bit MUST BE CLEAR for all other read modes as they do not have mode bits. If this bit is 0, bits 24, and [23:16] are ignored. Here is a summary of how bits 25, 24 and 23:16 are related: if ([Bit25 == 0] && [Bit24 == x]) then [Bits23:16 = x] if ([Bit25 == 1] && [Bit24 == 0]) then [Bits23:16 = ~(8'bxx10xxxx)] if ([Bit25 == 1] && [Bit24 == 1]) then [Bits23:16 = 8'bxx10xxxx] |
| XQSPIPS_LQSPI_CR_MODE_ON_MASK (MODE_ON) | 24 | rw | 0x1 | This bit is only relevant if bit 25 is set, else it is ignored. If this bit is set, instruction code is only sent for the very first read transfer. If this bit is clear, instruction code will be sent for all read transfers. This bit is configured in association with the MODE_BITS. For Winbond devices, this bit MUST BE SET if the MODE_BITS are 8'bxx10xxxx, else this bit MUST BE CLEAR. |

| Field Name | Bits | Type | Reset Value | Description |
|--|-------|------|-------------|--|
| XQSPIPS_LQSPI_CR_MODE_BITS_MASK (MODE_BITS) | 23:16 | rw | 0xA0 | These bits are only relevant if bit 25 is set, else it is ignored. If bit 25 is set, this value is required for both dual I/O read and quad I/O read. See vendor's datasheet for more information. For Winbond's device, the continuous read mode value is 8'bxx10xxxx to skip the instruction code for the next read transfer, else instruction code is sent for all read transfers. Bit 24 has to be configured accordingly with this value. |
| reserved | 15:11 | rw | x | Reserved, value is undefined when read. |
| XQSPIPS_LQSPI_CR_DUMMY_MASK (DUMMY) | 10:8 | rw | 0x2 | Number of dummy bytes between address and return read data |
| XQSPIPS_LQSPI_CR_INST_MASK (INST) | 7:0 | rw | 0xEB | Read instruction code. The known read instruction codes are: 8'h03 - Read 8'h0B - Fast read 8'h3B - Fast read dual output 8'h6B - Fast read quad output 8'hBB - Fast read dual I/O 8'hEB - Fast read quad I/O |

Register ([qspi](#)) XQSPIPS_LQSPI_SR_OFFSET

| | |
|------------------|---|
| Name | XQSPIPS_LQSPI_SR_OFFSET |
| Software Name | LQSPI_SR |
| Relative Address | 0x000000A4 |
| Absolute Address | 0xE000D0A4 |
| Width | 9 bits |
| Access Type | rw |
| Reset Value | 0x00000000 |
| Description | Status Register specifically for the Linear Quad-SPI Controller |

Register XQSPIPS_LQSPI_SR_OFFSET Details

| Field Name | Bits | Type | Reset Value | Description |
|--|------|------|-------------|------------------------|
| reserved | 8:3 | rw | 0x0 | Reserved |
| XQSPIPS_LQSPI_SR_FB_RECVD_MASK (FB_RECVD) | 2 | rw | 0x0 | Data FSM error, if set |

| Field Name | Bits | Type | Reset Value | Description |
|---|------|------|-------------|------------------------------------|
| XQSPIPS_LQSPI_SR_WR_RECVD_MASK (WR_RECVD) | 1 | rw | 0x0 | AXI write command received, if set |
| reserved | 0 | rw | 0x0 | Reserved |

Register ([qspi](#)) MOD_ID

| | |
|------------------|--------------------------------|
| Name | MOD_ID |
| Relative Address | 0x000000FC |
| Absolute Address | 0xE000D0FC |
| Width | 32 bits |
| Access Type | rw |
| Reset Value | 0x01090101 |
| Description | Module Identification register |

Register MOD_ID Details

| Field Name | Bits | Type | Reset Value | Description |
|------------|------|------|-------------|------------------|
| | 31:0 | rw | 0x1090101 | Module ID value. |

B.27 SD Controller (sdio)

Module Name SD Controller (sdio)
 Base Address 0xE0100000 sd0
 0xE0101000 sd1
 Description SD2.0/ SDIO2.0/ MMC3.31 AHB Host ControllerRegisters
 Vendor Info

Register Summary

| Register Name | Address | Width | Type | Reset Value | Description |
|--|------------|-------|-------|-------------|---|
| SDMA_system_address_register | 0x00000000 | 32 | rw | 0x00000000 | System DMA Address Register |
| Block_Size_Block_Count | 0x00000004 | 32 | mixed | 0x00000000 | Block size register Block count register |
| Argument | 0x00000008 | 32 | rw | 0x00000000 | Argument register |
| Transfer_Mode_Command | 0x0000000C | 32 | mixed | 0x00000000 | Transfer mode register Command register |
| Response0 | 0x00000010 | 32 | ro | 0x00000000 | Response register |
| Response1 | 0x00000014 | 32 | ro | 0x00000000 | Response register |
| Response2 | 0x00000018 | 32 | ro | 0x00000000 | Response register |
| Response3 | 0x0000001C | 32 | ro | 0x00000000 | Response register |
| Buffer_Data_Port | 0x00000020 | 32 | rw | 0x00000000 | Buffer data port register |
| Present_State | 0x00000024 | 25 | ro | 0x01F20000 | Present State register |
| Host_control_Power_control_Block_Gap_Control_Wakeup_control | 0x00000028 | 32 | mixed | 0x00000000 | Host control register Power control register Block gap control register Wake-up control register |
| Clock_Control_Timeout_control_Software_reset | 0x0000002C | 27 | mixed | 0x00000000 | Clock Control register Timeout control register Software reset register |
| Normal_interrupt_status_Error_interrupt_status | 0x00000030 | 30 | mixed | 0x00000000 | Normal interrupt status register Error interrupt status register |
| Normal_interrupt_status_enable_Error_interrupt_status_enable | 0x00000034 | 30 | mixed | 0x00000000 | Normal interrupt status enable register Error interrupt status enable register |
| Normal_interrupt_signal_enable_Error_interrupt_signal_enable | 0x00000038 | 30 | mixed | 0x00000000 | Normal interrupt signal enable register Error interrupt signal enable register |

| Register Name | Address | Width | Type | Reset Value | Description |
|--|------------|-------|-------|-------------|--|
| Auto_CMD12_error_status | 0x0000003C | 8 | ro | 0x00000000 | Auto CMD12 error status register |
| Capabilities | 0x00000040 | 31 | ro | 0x69EC0080 | Capabilities register |
| Maximum_current_capabilities | 0x00000048 | 24 | ro | 0x00000001 | Maximum current capabilities register |
| Force_event_for_AutoCMD12_Error_Status_Force_event_register_for_error_interrupt_status | 0x00000050 | 32 | mixed | 0x00000000 | Force event register for Auto CMD12 error status register Force event register for error interrupt status |
| ADMA_error_status | 0x00000054 | 3 | mixed | 0x00000000 | ADMA error status register |
| ADMA_system_address | 0x00000058 | 32 | rw | 0x00000000 | ADMA system address register |
| Boot_Timeout_control | 0x00000060 | 32 | rw | 0x00000000 | Boot Timeout control register |
| Debug_Selection | 0x00000064 | 1 | wo | 0x00000000 | Debug Selection Register |
| SPI_interrupt_support | 0x000000F0 | 8 | rw | 0x00000000 | SPI interrupt support register |
| Slot_interrupt_status_Host_controller_version | 0x000000FC | 32 | ro | 0x89010000 | Slot interrupt status register and Host controller version register |

Register ([sdio](#)) SDMA_system_address_register

| | |
|------------------|------------------------------------|
| Name | SDMA_system_address_register |
| Relative Address | 0x00000000 |
| Absolute Address | sd0: 0xE0100000 sd1: 0xE0101000 |
| Width | 32 bits |
| Access Type | rw |
| Reset Value | 0x00000000 |
| Description | System DMA Address Register |

Register SDMA_system_address_register Details

This register contains the system memory address for a DMA transfer. When the Host Controller (HC) stops a DMA transfer, this register shall point to the system address of the next contiguous data position. It can be accessed only if no transaction is executing (i.e. after a transaction has stopped). Read operations during transfer return an invalid value. The Host Driver (HD) shall initialize this register before starting a DMA transaction. After DMA has stopped, the next system address of the next contiguous data position can be read from this register. The DMA transfer waits at every boundary specified by the Host DMA Buffer Size in the Block Size register. The Host Controller generates DMA Interrupt to request to update this register. The HD sets the next system address of the next data position to this register. When most upper byte of this register (003h) is written, the HC restart the DMA transfer. When restarting DMA by the resume command or by setting Continue Request in the Block Gap Control register, the HC shall start at the next contiguous address stored here in the System Address register

| Field Name | Bits | Type | Reset Value | Description |
|---------------------|------|------|-------------|--|
| SDMA_System_Address | 31:0 | rw | 0x0 | Watchdog enable - if set, the watchdog is enabled and can generate any signals that are enabled. |

Register ([sdio](#)) Block_Size_Block_Count

| | |
|------------------|---|
| Name | Block_Size_Block_Count |
| Relative Address | 0x00000004 |
| Absolute Address | sd0: 0xE0100004 sd1: 0xE0101004 |
| Width | 32 bits |
| Access Type | mixed |
| Reset Value | 0x00000000 |
| Description | Block size register Block count register |

Register Block_Size_Block_Count Details

| Field Name | Bits | Type | Reset Value | Description |
|-----------------------------------|-------|------|-------------|--|
| Blocks_Count_for_Current_Transfer | 31:16 | rw | 0x0 | This register is enabled when Block Count Enable in the Transfer Mode register is set to 1 and is valid only for multiple block transfers. The HC decrements the block count after each block transfer and stops when the count reaches zero. It can be accessed only if no transaction is executing (i.e. after a transaction has stopped). Read operations during transfer return an invalid value and write operations shall be ignored. When saving transfer context as a result of Suspend command, the number of blocks yet to be transferred can be determined by reading this register. When restoring transfer context prior to issuing a Resume command, the HD shall restore the previously save block count. 0000h - Stop Count 0001h - 1 block 0002h - 2 blocks ---- FFFFh - 65535 blocks |
| reserved | 15 | ro | 0x0 | Reserved |

| Field Name | Bits | Type | Reset Value | Description |
|-----------------------|-------|------|-------------|---|
| Host_SDMA_Buffer_Size | 14:12 | rw | 0x0 | <p>To perform long DMA transfer, the System Address register shall be updated at every system boundary during a DMA transfer. These bits specify the size of contiguous buffer in the system memory. The DMA transfer shall wait at every boundary specified by these fields and the HC generates the DMA Interrupt to request the HD to update the System Address register.</p> <p>These bits shall support when the DMA Support in the Capabilities register is set to 1 and this function is active when the DMA Enable in the Transfer Mode register is set to 1.</p> <p>000b - 4KB(Detects A11 Carry out) 001b - 8KB(Detects A12 Carry out) 010b - 16KB(Detects A13 Carry out) 011b - 32KB(Detects A14 Carry out) 100b - 64KB(Detects A15 Carry out) 101b -128KB(Detects A16 Carry out) 110b - 256KB(Detects A17 Carry out) 111b - 512KB(Detects A18 Carry out)</p> |
| Transfer_Block_Size | 11:0 | rw | 0x0 | <p>This register specifies the block size for block data transfers for CMD17, CMD18, CMD24, CMD25, and CMD53. It can be accessed only if no transaction is executing (i.e. after a transaction has stopped). Read operations during transfer return an invalid value and write operations shall be ignored.</p> <p>0000h - No Data Transfer 0001h - 1 Byte 0002h - 2 Bytes 0003h - 3 Bytes 0004h - 4 Bytes --- --- 01FFh - 511 Bytes 0200h - 512 Bytes --- --- 0800h - 2048 Bytes</p> |

Register ([sdio](#)) Argument

| | |
|------------------|------------------------------------|
| Name | Argument |
| Relative Address | 0x00000008 |
| Absolute Address | sd0: 0xE0100008 sd1: 0xE0101008 |
| Width | 32 bits |
| Access Type | rw |
| Reset Value | 0x00000000 |

Description Argument register

Register Argument Details

| Field Name | Bits | Type | Reset Value | Description |
|------------------|------|------|-------------|---|
| Command_Argument | 31:0 | rw | 0x0 | The SD Command Argument is specified as bit 39-8 of Command-Format. |

Register ([sdio](#)) Transfer_Mode_Command

Name Transfer_Mode_Command
 Relative Address 0x0000000C
 Absolute Address sd0: 0xE010000C
 sd1: 0xE010100C
 Width 32 bits
 Access Type mixed
 Reset Value 0x00000000
 Description Transfer mode register
 Command register

Register Transfer_Mode_Command Details

| Field Name | Bits | Type | Reset Value | Description |
|---------------|-------|------|-------------|--|
| reserved | 31:30 | ro | 0x0 | Reserved |
| Command_Index | 29:24 | rw | 0x0 | This bit shall be set to the command number (CMD0-63, ACMD0-63). |

| Field Name | Bits | Type | Reset Value | Description |
|----------------------------|-------|------|-------------|--|
| Command_Type | 23:22 | rw | 0x0 | <p>There are three types of special commands. Suspend, Resume and Abort. These bits shall be set to 00b for all other commands. Suspend Command If the Suspend command succeeds, the HC shall assume the SD Bus has been released and that it is possible to issue the next command which uses the DAT line. The HC shall de-assert Read Wait for read transactions and stop checking busy for write transactions. The Interrupt cycle shall start, in 4-bit mode. If the Suspend command fails, the HC shall maintain its current state. and the HD shall restart the transfer by setting Continue Request in the Block Gap Control Register. Resume Command The HD re-starts the data transfer by restoring the registers in the range of 000-00Dh. The HC shall check for busy before starting write transfers. Abort Command If this command is set when executing a read transfer, the HC shall stop reads to the buffer. If this command is set when executing a write transfer, the HC shall stop driving the DAT line. After issuing the Abort command, the HD should issue a software reset</p> <p>00b - Normal 01b - Suspend 10b - Resume 11b - Abort</p> |
| Data_Present_Select | 21 | rw | 0x0 | <p>This bit is set to 1 to indicate that data is present and shall be transferred using the DAT line. If is set to 0 for the following:</p> <ol style="list-style-type: none"> 1. Commands using only CMD line (ex. CMD52) 2. Commands with no data transfer but using busy signal on DAT[0] line (R1b or R5b ex. CMD38) 3. Resume Command <p>0 - No Data Present 1 - Data Present</p> |
| Command_Index_Check_Enable | 20 | rw | 0x0 | <p>If this bit is set to 1, the HC shall check the index field in the response to see if it has the same value as the command index. If it is not, it is reported as a Command Index Error. If this bit is set to 0, the Index field is not checked.</p> <p>0 - Disable 1 - Enable</p> |
| Command_CRC_Check_Enable | 19 | rw | 0x0 | <p>If this bit is set to 1, the HC shall check the CRC field in the response. If an error is detected, it is reported as a Command CRC Error. If this bit is set to 0, the CRC field is not checked.</p> <p>0 - Disable 1 - Enable</p> |
| reserved | 18 | ro | 0x0 | Reserved |

| Field Name | Bits | Type | Reset Value | Description |
|--------------------------------|-------|------|-------------|---|
| Response_Type_Select | 17:16 | rw | 0x0 | Response Type Select 00 - No Response 01 - Response length 136 10 - Response length 48 11 - Response length 48 check Busy after response |
| reserved | 15:6 | ro | 0x0 | Reserved |
| Multi_Single_Block_Select | 5 | rw | 0x0 | This bit enables multiple block DAT line data transfers. 0 - Single Block 1 - Multiple Block |
| Data_Transfer_Direction_Select | 4 | rw | 0x0 | This bit defines the direction of DAT line data transfers. 0 - Write (Host to Card) 1 - Read (Card to Host) |
| reserved | 3 | ro | 0x0 | Reserved |
| Auto_CMD12_Enable | 2 | rw | 0x0 | Multiple block transfers for memory require CMD12 to stop the transaction. When this bit is set to 1, the HC shall issue CMD12 automatically when last block transfer is completed. The HD shall not set this bit to issue commands that do not require CMD12 to stop data transfer. 0 - Disable 1 - Enable |
| Block_Count_Enable | 1 | rw | 0x0 | This bit is used to enable the Block count register, which is only relevant for multiple block transfers. When this bit is 0, the Block Count register is disabled, which is useful in executing an infinite transfer. 0 - Disable 1 - Enable |
| DMA_Enable | 0 | rw | 0x0 | DMA can be enabled only if DMA Support bit in the Capabilities register is set. If this bit is set to 1, a DMA operation shall begin when the HD writes to the upper byte of Command register (00Fh). 0 - Disable 1 - Enable |

Register ([sdio](#)) Response0

Name Response0
 Relative Address 0x00000010
 Absolute Address sd0: 0xE0100010
 sd1: 0xE0101010
 Width 32 bits

Access Type ro
 Reset Value 0x00000000
 Description Response register

Note: This register is the first in an array of 4 identical registers listed in the table below. The details provided in this section apply to the entire array.

| Name | Address |
|-----------|------------|
| Response0 | 0xe0100010 |
| Response1 | 0xe0100014 |
| Response2 | 0xe0100018 |
| Response3 | 0xe010001c |

Register Response0 to Response3 Details

| Field Name | Bits | Type | Reset Value | Description |
|------------------|------|------|-------------|-----------------------------|
| Command_Response | 31:0 | ro | 0x0 | command responses registers |

Register ([sdio](#)) Buffer_Data_Port

Name Buffer_Data_Port
 Relative Address 0x00000020
 Absolute Address sd0: 0xE0100020
 sd1: 0xE0101020
 Width 32 bits
 Access Type rw
 Reset Value 0x00000000
 Description Buffer data port register

Register Buffer_Data_Port Details

| Field Name | Bits | Type | Reset Value | Description |
|-------------|------|------|-------------|--|
| Buffer_Data | 31:0 | rw | 0x0 | The Host Controller Buffer can be accessed through this 32-bit Data Port Register. |

Register ([sdio](#)) Present_State

Name Present_State
 Relative Address 0x00000024

Absolute Address sd0: 0xE0100024
 sd1: 0xE0101024
 Width 25 bits
 Access Type ro
 Reset Value 0x01F20000
 Description Present State register

Register Present_State Details

| Field Name | Bits | Type | Reset Value | Description |
|---------------------------------|-------|------|-------------|--|
| CMD_Line_Signal_Level | 24 | ro | 0x1 | This status is used to check CMD line level to recover from errors, and for debugging. |
| DAT_Bit3_Bit0_Line_Signal_Level | 23:20 | ro | 0xF | This status is used to check DAT line level to recover from errors, and for debugging. This is especially useful in detecting the busy signal level from DAT[0]. D23 - DAT[3] D22 - DAT[2] D21 - DAT[1] D20 - DAT[0] |
| Write_Protect_Switch_Pin_Level | 19 | ro | 0x0 | The Write Protect Switch is supported for memory and combo cards. This bit reflects the inversion of the SDx_WP pin. 0 - Write protected (SDx_WP pin = High) 1 - Write enabled (SDx_WP pin = Low) |
| Card_Detect_Pin_Level | 18 | ro | 0x0 | This bit reflects the inverse value of the SDx_CDn pin. 0 - No Card present (SDx_CDn = High) 1 - Card present (SDx_CDn = Low) |
| Card_State_Stable | 17 | ro | 0x1 | This bit is used for testing. If it is 0, the Card Detect Pin Level is not stable. If this bit is set to 1, it means the Card Detect Pin Level is stable. The Software Reset For All in the Software Reset Register shall not affect this bit. 0 - Reset of Debouncing 1 - No Card or Inserted |

| Field Name | Bits | Type | Reset Value | Description |
|---------------------|-------|------|-------------|--|
| Card_Inserted | 16 | ro | 0x0 | <p>This bit indicates whether a card has been inserted. Changing from 0 to 1 generates a Card Insertion interrupt in the Normal Interrupt Status register and changing from 1 to 0 generates a Card Removal Interrupt in the Normal Interrupt Status register. The Software Reset For All in the Software Reset register shall not affect this bit. If a Card is removed while its power is on and its clock is oscillating, the HC shall clear SD Bus Power in the Power Control register and SD Clock Enable in the Clock control register. In addition the HD should clear the HC by the Software Reset For All in Software register. The card detect is active regardless of the SD Bus Power.</p> <p>0 - Reset or Debouncing or No Card 1 - Card Inserted</p> |
| reserved | 15:12 | ro | 0x0 | Reserved |
| Buffer_Read_Enable | 11 | ro | 0x0 | <p>This status is used for non-DMA read transfers. This read only flag indicates that valid data exists in the host side buffer status. If this bit is 1, readable data exists in the buffer. A change of this bit from 1 to 0 occurs when all the block data is read from the buffer. A change of this bit from 0 to 1 occurs when all the block data is ready in the buffer and generates the Buffer Read Ready Interrupt.</p> <p>0 - Read Disable 1 - Read Enable.</p> |
| Buffer_Write_Enable | 10 | ro | 0x0 | <p>This status is used for non-DMA write transfers. This read only flag indicates if space is available for write data. If this bit is 1, data can be written to the buffer. A change of this bit from 1 to 0 occurs when all the block data is written to the buffer. A change of this bit from 0 to 1 occurs when top of block data can be written to the buffer and generates the Buffer Write Ready Interrupt.</p> <p>0 - Write Disable 1 - Write Enable.</p> |

| Field Name | Bits | Type | Reset Value | Description |
|-----------------------|------|------|-------------|---|
| Read_Transfer_Active | 9 | ro | 0x0 | <p>This status is used for detecting completion of a read transfer.</p> <p>This bit is set to 1 for either of the following conditions:</p> <ol style="list-style-type: none"> 1. After the end bit of the read command 2. When writing a 1 to continue Request in the Block Gap Control register to restart a read transfer <p>This bit is cleared to 0 for either of the following conditions:</p> <ol style="list-style-type: none"> 1. When the last data block as specified by block length is transferred to the system. 2. When all valid data blocks have been transferred to the system and no current block transfers are being sent as a result of the Stop At Block Gap Request set to 1. A transfer complete interrupt is generated when this bit changes to 0. <p>1 - Transferring data 0 - No valid data</p> |
| Write_Transfer_Active | 8 | ro | 0x0 | <p>This status indicates a write transfer is active. If this bit is 0, it means no valid write data exists in the HC. This bit is set in either of the following cases:</p> <ol style="list-style-type: none"> 1. After the end bit of the write command. 2. When writing a 1 to Continue Request in the Block Gap Control register to restart a write transfer. <p>This bit is cleared in either of the following cases:</p> <ol style="list-style-type: none"> 1. After getting the CRC status of the last data block as specified by the transfer count (Single or Multiple) 2. After getting a CRC status of any block where data transmission is about to be stopped by a Stop At Block Gap Request. <p>During a write transaction, a Block Gap Event interrupt is generated when this bit is changed to 0, as a result of the Stop At Block Gap Request being set. This status is useful for the HD in determining when to issue commands during write busy.</p> <p>1 - transferring data 0 - No valid data</p> |
| reserved | 7:3 | ro | 0x0 | Reserved |
| DAT_Line_Active | 2 | ro | 0x0 | <p>This bit indicates whether one of the DAT line on SD bus is in use.</p> <p>1 - DAT line active 0 - DAT line inactive</p> |

| Field Name | Bits | Type | Reset Value | Description |
|---------------------|------|------|-------------|---|
| Command_Inhibit_DAT | 1 | ro | 0x0 | <p>This status bit is generated if either the DAT Line Active or the Read transfer Active is set to 1. If this bit is 0, it indicates the HC can issue the next SD command. Commands with busy signal belong to Command Inhibit (DAT) (ex. R1b, R5b type). Changing from 1 to 0 generates a Transfer Complete interrupt in the Normal interrupt status register.</p> <p>Note: The SD Host Driver can save registers in the range of 000-00Dh for a suspend transaction after this bit has changed from 1 to 0.</p> <p>1 - cannot issue command which uses the DAT line 0 - Can issue command which uses the DAT line</p> |
| Command_Inhibit_CMD | 0 | ro | 0x0 | <p>If this bit is 0, it indicates the CMD line is not in use and the HC can issue a SD command using the CMD line. This bit is set immediately after the Command register (00Fh) is written. This bit is cleared when the command response is received. Even if the Command Inhibit (DAT) is set to 1, Commands using only the CMD line can be issued if this bit is 0. Changing from 1 to 0 generates a Command complete interrupt in the Normal Interrupt Status register. If the HC cannot issue the command because of a command conflict error or because of Command Not Issued By Auto CMD12 Error, this bit shall remain 1 and the Command Complete is not set. Status issuing Auto CMD12 is not read from this bit. Note: The SD host controller requires couple of clocks to update this register bit after the command is posted to command register.</p> |

Register ([sdio](#))

Host_control_Power_control_Block_Gap_Control_Wakeup_control

| | |
|------------------|---|
| Name | Host_control_Power_control_Block_Gap_Control_Wakeup_control |
| Relative Address | 0x00000028 |
| Absolute Address | sd0: 0xE0100028 sd1: 0xE0101028 |
| Width | 32 bits |
| Access Type | mixed |
| Reset Value | 0x00000000 |
| Description | Host control register Power control register Block gap control register Wake-up control register |

Register Host_control_Power_control_Block_Gap_Control_Wakeup_control Details

| Field Name | Bits | Type | Reset Value | Description |
|--|-------|------|-------------|--|
| reserved | 31:27 | ro | 0x0 | Reserved |
| Wakeup_Event_Enable_On_SD_Card_Removal | 26 | rw | 0x0 | This bit enables wakeup event via Card Removal assertion in the Normal Interrupt Status register. FN_WUS (Wake up Support) in CIS does not affect this bit. 1 - Enable 0 - Disable |
| Wakeup_Event_Enable_On_SD_Card_Insertion | 25 | rw | 0x0 | This bit enables wakeup event via Card Insertion assertion in the Normal Interrupt Status register. FN_WUS (Wake up Support) in CIS does not affect this bit. 1 - Enable 0 - Disable |
| Wakeup_Event_Enable_On_Card_Interrupt | 24 | rw | 0x0 | This bit enables wakeup event via Card Interrupt assertion in the Normal Interrupt Status register. This bit can be set to 1 if FN_WUS (Wake Up Support) in CIS is set to 1. 1 - Enable 0 - Disable |
| reserved | 23:20 | ro | 0x0 | Reserved |
| Interrupt_At_Block_Gap | 19 | rw | 0x0 | This bit is valid only in 4-bit mode of the SDIO card and selects a sample point in the interrupt cycle. Setting to 1 enables interrupt detection at the block gap for a multiple block transfer. If the SD card cannot signal an interrupt during a multiple block transfer, this bit should be set to 0. When the HD detects an SD card insertion, it shall set this bit according to the CCCR of the SDIO card. |

| Field Name | Bits | Type | Reset Value | Description |
|-------------------|------|------|-------------|---|
| Read_Wait_Control | 18 | rw | 0x0 | <p>The read wait function is optional for SDIO cards. If the card supports read wait, set this bit to enable use of the read wait protocol to stop read data using DAT[2] line. Otherwise the HC has to stop the SD clock to hold read data, which restricts commands generation. When the HD detects an SD card insertion, it shall set this bit according to the CCCR of the SDIO card. If the card does not support read wait, this bit shall never be set to 1 otherwise DAT line conflict may occur. If this bit is set to 0, Suspend / Resume cannot be supported</p> <p>1 - Enable Read Wait Control 0 - Disable Read Wait Control</p> |
| Continue_Request | 17 | rw | 0x0 | <p>This bit is used to restart a transaction which was stopped using the Stop At Block Gap Request. To cancel stop at the block gap, set Stop At block Gap Request to 0 and set this bit to restart the transfer.</p> <p>The HC automatically clears this bit in either of the following cases:</p> <p>1) In the case of a read transaction, the DAT Line Active changes from 0 to 1 as a read transaction restarts.</p> <p>2) In the case of a write transaction, the Write transfer active changes from 0 to 1 as the write transaction restarts.</p> <p>Therefore it is not necessary for Host driver to set this bit to 0. If Stop At Block Gap Request is set to 1, any write to this bit is ignored.</p> <p>1 - Restart 0 - Ignored</p> |

| Field Name | Bits | Type | Reset Value | Description |
|------------------------------|-------|------|-------------|---|
| Stop_At_Block_Gap_Request | 16 | rw | 0x0 | This bit is used to stop executing a transaction at the next block gap for non- DMA,SDMA and ADMA transfers. Until the transfer complete is set to 1, indicating a transfer completion the HD shall leave this bit set to 1. Clearing both the Stop At Block Gap Request and Continue Request shall not cause the transaction to restart. Read Wait is used to stop the read transaction at the block gap. The HC shall honor Stop At Block Gap Request for write transfers, but for read transfers it requires that the SD card support Read Wait. Therefore the HD shall not set this bit during read transfers unless the SD card supports Read Wait and has set Read Wait Control to 1. In case of write transfers in which the HD writes data to the Buffer Data Port register, the HD shall set this bit after all block data is written. If this bit is set to 1, the HD shall not write data to Buffer data port register. This bit affects Read Transfer Active, Write Transfer Active, DAT line active and Command Inhibit (DAT) in the Present State register. 1 - Stop 0 - Transfer |
| reserved | 15:12 | ro | 0x0 | Reserved |
| SD_Bus_Voltage_Select | 11:9 | rw | 0x0 | By setting these bits, the HD selects the voltage level for the SD card. Before setting this register, the HD shall check the voltage support bits in the capabilities register. If an unsupported voltage is selected, the Host System shall not supply SD bus voltage 111b - 3.3 Flattop.) 110b - 3.0 V(Typ.) 101b - 1.8 V(Typ.) 100b - 000b - Reserved |
| SD_Bus_Power | 8 | rw | 0x0 | Before setting this bit, the SD host driver shall set SD Bus Voltage Select. If the HC detects the No Card State, this bit shall be cleared. 1 - Power on 0 - Power off |
| Card_detect_signal_detection | 7 | rw | 0x0 | This bit selects source for card detection. 1- The card detect test level is selected 0 -SDCD# is selected (for normal use) |
| Card_Detect_Test_Level | 6 | rw | 0x0 | This bit is enabled while the Card Detect Signal Selection is set to 1 and it indicates card inserted or not. Generates (card ins or card removal) interrupt when the normal int sts enable bit is set. 1 - Card Inserted 0 - No Card |

| Field Name | Bits | Type | Reset Value | Description |
|------------------------------------|------|------|-------------|---|
| reserved | 5 | ro | 0x0 | Reserved |
| DMA_Select | 4:3 | rw | 0x0 | One of supported DMA modes can be selected. The host driver shall check support of DMA modes by referring the Capabilities register. 00 - SDMA is selected 01 - 32-bit Address ADMA1 is selected 10 -32-bit Address ADMA2 is selected 11 - 64-bit Address ADMA2 is selected |
| High_Speed_Enable | 2 | rw | 0x0 | This bit is optional. Before setting this bit, the HD shall check the High Speed Support in the capabilities register. If this bit is set to 0 (default), the HC outputs CMD line and DAT lines at the falling edge of the SD clock (up to 25 MHz/20 MHz for MMC). If this bit is set to 1, the HC outputs CMD line and DAT lines at the rising edge of the SD clock (up to 50 MHz for SD/52 MHz for MMC) 1 - High Speed Mode 0 - Normal Speed Mode |
| Data_Transfer_Width_S D1_or_SD4 | 1 | rw | 0x0 | This bit selects the data width of the HC. The HD shall select it to match the data width of the SD card. 1 - 4 bit mode 0 - 1 bit mode |
| LED_Control | 0 | rw | 0x0 | This bit is used to caution the user not to remove the card while the SD card is being accessed. If the software is going to issue multiple SD commands, this bit can be set during all transactions. It is not necessary to change for each transaction. 1 - LED on 0 - LED off |

Register ([sdio](#)) **Clock_Control_Timeout_control_Software_reset**

| | |
|------------------|---|
| Name | Clock_Control_Timeout_control_Software_reset |
| Relative Address | 0x0000002C |
| Absolute Address | sd0: 0xE010002C sd1: 0xE010102C |
| Width | 27 bits |
| Access Type | mixed |
| Reset Value | 0x00000000 |
| Description | Clock Control register Timeout control register Software reset register |

Register Clock_Control_Timeout_control_Software_reset Details

| Field Name | Bits | Type | Reset Value | Description |
|---------------------------------|-------|------|-------------|---|
| Software_Reset_for_DAT_Line | 26 | rw | 0x0 | Only part of data circuit is reset. The following registers and bits are cleared by this bit: Buffer Data Port Register Buffer is cleared and Initialized. Present State register Buffer read Enable Buffer write Enable Read Transfer Active Write Transfer Active DAT Line Active Command Inhibit (DAT) Block Gap Control register Continue Request Stop At Block Gap Request Normal Interrupt Status register Buffer Read Ready Buffer Write Ready Block Gap Event Transfer Complete 1 - Reset 0 - Work |
| Software_Reset_for_COMMAND_Line | 25 | rw | 0x0 | Only part of command circuit is reset. The following registers and bits are cleared by this bit: Present State register Command Inhibit (CMD) Normal Interrupt Status register Command Complete 1 - Reset 0 - Work |
| Software_Reset_for_All | 24 | rw | 0x0 | This reset affects the entire HC except for the card detection circuit. Register bits of type ROC, RW, RW1C, RWAC are cleared to 0. During its initialization, the HD shall set this bit to 1 to reset the HC. The HC shall reset this bit to 0 when capabilities registers are valid and the HD can read them. Additional use of Software Reset For All may not affect the value of the Capabilities registers. If this bit is set to 1, the SD card shall reset itself and must be re initialized by the HD. 1 - Reset 0 - Work |
| reserved | 23:20 | ro | 0x0 | Reserved |

| Field Name | Bits | Type | Reset Value | Description |
|-----------------------------|-------|------|-------------|--|
| Data_Timeout_Counter_Value_ | 19:16 | rw | 0x0 | <p>This value determines the interval by which DAT line time-outs are detected. Refer to the Data Timeout Error in the Error Interrupt Status register for information on factors that dictate Timeout generation. Timeout clock frequency will be generated by dividing the sdclockTMCLK by this value. When setting this register, prevent inadvertent Timeout events by clearing the Data Time-out Error Status Enable (in the Error Interrupt Status Enable register)</p> <p>1111 - Reserved 1110 - TMCLK * 2²⁷ ----- ----- 0001 - TMCLK * 2¹⁴ 0000 - TMCLK * 2¹³</p> |
| SDCLK_Frequency_Select | 15:8 | rw | 0x0 | <p>This register is used to select the frequency of the SDCLK pin. The frequency is not programmed directly; rather this register holds the divisor of the Base Clock Frequency For SD clock in the capabilities register. Only the following settings are allowed.</p> <p>80h - base clock divided by 256 40h - base clock divided by 128 20h - base clock divided by 64 10h - base clock divided by 32 08h - base clock divided by 16 04h - base clock divided by 8 02h - base clock divided by 4 01h - base clock divided by 2 00h - base clock(10MHz-63MHz)</p> <p>Setting 00h specifies the highest frequency of the SD Clock. When setting multiple bits, the most significant bit is used as the divisor. But multiple bits should not be set. The two default divider values can be calculated by the frequency that is defined by the Base Clock Frequency For SD Clock in the Capabilities register.</p> <p>1) 25 MHz divider value 2) 400 KHz divider value</p> <p>The frequency of the SDCLK is set by the following formula: Clock Frequency = (Baseclock) / divisor. Thus choose the smallest possible divisor which results in a clock frequency that is less than or equal to the target frequency. Maximum Frequency for SD = 50Mhz (base clock) Maximum Frequency for MMC = 52Mhz (base clock) Minimum Frequency = 195.3125Khz (50Mhz / 256), same calc for MMC also</p> |

| Field Name | Bits | Type | Reset Value | Description |
|-----------------------|------|------|-------------|--|
| reserved | 7:3 | ro | 0x0 | Reserved |
| SD_Clock_Enable | 2 | rw | 0x0 | The HC shall stop SDCLK when writing this bit to 0. SDCLK frequency Select can be changed when this bit is 0. Then, the HC shall maintain the same clock frequency until SDCLK is stopped (Stop at SDCLK = 0). If the HC detects the No Card state, this bit shall be cleared. 1 - Enable 0 - Disable |
| Internal_Clock_Stable | 1 | ro | 0x0 | This bit is set to 1 when SD clock is stable after writing to Internal Clock Enable in this register to 1. The SD Host Driver shall wait to set SD Clock Enable until this bit is set to 1. Note: This is useful when using PLL for a clock oscillator that requires setup time. 1 - Ready 0 - Not Ready |
| Internal_Clock_Enable | 0 | rw | 0x0 | This bit is set to 0 when the HD is not using the HC or the HC awaits a wakeup event. The HC should stop its internal clock to go very low power state. Still, registers shall be able to be read and written. Clock starts to oscillate when this bit is set to 1. When clock oscillation is stable, the HC shall set Internal Clock Stable in this register to 1. This bit shall not affect card detection. 1 - Oscillate 0 - Stop |

Register ([sdio](#)) Normal_interrupt_status_Error_interrupt_status

Name Normal_interrupt_status_Error_interrupt_status

Relative Address 0x00000030

Absolute Address sd0: 0xE0100030
sd1: 0xE0101030

Width 30 bits

Access Type mixed

Reset Value 0x00000000

Description Normal interrupt status register
Error interrupt status register

Register Normal_interrupt_status_Error_interrupt_status Details

| Field Name | Bits | Type | Reset Value | Description |
|-----------------------|-------|------|-------------|---|
| Ceata_Error_Status | 29 | wtc | 0x0 | Occurs when ATA command termination has occurred due to an error condition the device has encountered. 0 - no error 1 - error |
| Target_Response_error | 28 | wtc | 0x0 | Occurs when detecting ERROR in m_hresp(dma transaction) 0 - no error 1 - error |
| reserved | 27:26 | ro | 0x0 | Reserved |
| ADMA_Error | 25 | wtc | 0x0 | This bit is set when the Host Controller detects errors during ADMA based data transfer. The state of the ADMA at an error occurrence is saved in the ADMA Error Status Register. 1- Error 0 -No error |
| Auto_CMD12_Error | 24 | wtc | 0x0 | Occurs when detecting that one of the bits in Auto CMD12 Error Status register has changed from 0 to 1. This bit is set to 1 also when Auto CMD12 is not executed due to the previous command error. 0 - No Error 1 - Error |
| Current_Limit_Error | 23 | wtc | 0x0 | By setting the SD Bus Power bit in the Power Control Register, the HC is requested to supply power for the SD Bus. If the HC supports the Current Limit Function, it can be protected from an Illegal card by stopping power supply to the card in which case this bit indicates a failure status. Reading 1 means the HC is not supplying power to SD card due to some failure. Reading 0 means that the HC is supplying power and no error has occurred. This bit shall always set to be 0, if the HC does not support this function. 0 - No Error 1 - Power Fail |
| Data_End_Bit_Error | 22 | wtc | 0x0 | Occurs when detecting 0 at the end bit position of read data which uses the DAT line or the end bit position of the CRC status. 0 - No Error 1 - Error |
| Data_CRC_Error | 21 | wtc | 0x0 | Occurs when detecting CRC error when transferring read data which uses the DAT line or when detecting the Write CRC Status having a value of other than '010'. 0 - No Error 1 - Error |

| Field Name | Bits | Type | Reset Value | Description |
|--------------------------|-------|------|-------------|--|
| Data_Timeout_Error | 20 | wtc | 0x0 | Occurs when detecting one of following timeout conditions. 1. Busy Timeout for R1b, R5b type. 2. Busy Timeout after Write CRC status 3. Write CRC status Timeout 4. Read Data Timeout 0 - No Error 1 - Timeout |
| Command_Index_Error | 19 | wtc | 0x0 | Occurs if a Command Index error occurs in the Command Response. 0 - No Error 1 - Error |
| Command_End_Bit_Error | 18 | wtc | 0x0 | Occurs when detecting that the end bit of a command response is 0. 0 - No Error 1 - End Bit Error Generated |
| Command_CRC_Error | 17 | wtc | 0x0 | Command CRC Error is generated in two cases. 1. If a response is returned and the Command Timeout Error is set to 0, this bit is set to 1 when detecting a CRT error in the command response 2. The HC detects a CMD line conflict by monitoring the CMD line when a command is issued. If the HC drives the CMD line to 1 level, but detects 0 level on the CMD line at the next SDCLK edge, then the HC shall abort the command (Stop driving CMD line) and set this bit to 1. The Command Timeout Error shall also be set to 1 to distinguish CMD line conflict. 0 - No Error 1 - CRC Error Generated |
| Command_Timeout_Error | 16 | wtc | 0x0 | Occurs only if the no response is returned within 64 SDCLK cycles from the end bit of the command. If the HC detects a CMD line conflict, in which case Command CRC Error shall also be set. This bit shall be set without waiting for 64 SDCLK cycles because the command will be aborted by the HC. 0 - No Error 1 - Timeout |
| Error_Interrupt | 15 | ro | 0x0 | If any of the bits in the Error Interrupt Status Register are set, then this bit is set. Therefore the HD can test for an error by checking this bit first. 0 - No Error. 1 - Error. |
| reserved | 14:11 | ro | 0x0 | Reserved |
| Boot_terminate_Interrupt | 10 | wtc | 0x0 | This status is set if the boot operation get terminated 0 - Boot operation is not terminated. 1 - Boot operation is terminated |

| Field Name | Bits | Type | Reset Value | Description |
|-------------------|------|------|-------------|---|
| Boot_ack_rcv | 9 | wtc | 0x0 | This status is set if the boot acknowledge is received from device. 0 - Boot ack is not received. 1 - Boot ack is received. |
| Card_Interrupt | 8 | ro | 0x0 | Writing this bit to 1 does not clear this bit. It is cleared by resetting the SD card interrupt factor. In 1-bit mode, the HC shall detect the Card Interrupt without SD Clock to support wakeup. In 4-bit mode, the card interrupt signal is sampled during the interrupt cycle, so there are some sample delays between the interrupt signal from the card and the interrupt to the Host system. when this status has been set and the HD needs to start this interrupt service, Card Interrupt Status Enable in the Normal Interrupt Status register shall be set to 0 in order to clear the card interrupt statuses latched in the HC and stop driving the Host System. After completion of the card interrupt service (the reset factor in the SD card and the interrupt signal may not be asserted), set Card Interrupt Status Enable to 1 and start sampling the interrupt signal again. 0 - No Card Interrupt 1 - Generate Card Interrupt |
| Card_Removal | 7 | wtc | 0x0 | This status is set if the Card Inserted in the Present State register changes from 1 to 0. When the HD writes this bit to 1 to clear this status the status of the Card Inserted in the Present State register should be confirmed. Because the card detect may possibly be changed when the HD clear this bit an Interrupt event may not be generated. 0 - Card State Stable or Debouncing 1 - Card Removed |
| Card_Insertion | 6 | wtc | 0x0 | This status is set if the Card Inserted in the Present State register changes from 0 to 1. When the HD writes this bit to 1 to clear this status the status of the Card Inserted in the Present State register should be confirmed. Because the card detect may possibly be changed when the HD clear this bit an Interrupt event may not be generated. 0 - Card State Stable or Debouncing 1 - Card Inserted |
| Buffer_Read_Ready | 5 | wtc | 0x0 | This status is set if the Buffer Read Enable changes from 0 to 1. 0 - Not Ready to read Buffer. 1 - Ready to read Buffer. |

| Field Name | Bits | Type | Reset Value | Description |
|--------------------|------|------|-------------|--|
| Buffer_Write_Ready | 4 | wtc | 0x0 | This status is set if the Buffer Write Enable changes from 0 to 1. 0 - Not Ready to Write Buffer. 1 - Ready to Write Buffer. |
| DMA_Interrupt | 3 | wtc | 0x0 | This status is set if the HC detects the Host DMA Buffer Boundary in the Block Size register. 0 - No DMA Interrupt 1 - DMA Interrupt is Generated |
| Block_Gap_Event | 2 | wtc | 0x0 | If the Stop At Block Gap Request in the Block Gap Control Register is set, this bit is set. Read Transaction: This bit is set at the falling edge of the DAT Line Active Status (When the transaction is stopped at SD Bus timing. The Read Wait must be supported in order to use this function). Write Transaction: This bit is set at the falling edge of Write Transfer Active Status (After getting CRC status at SD Bus timing). 0 - No Block Gap Event 1 - Transaction stopped at Block Gap |

| Field Name | Bits | Type | Reset Value | Description |
|-------------------|------|------|-------------|---|
| Transfer_Complete | 1 | wtc | 0x0 | <p>This bit is set when a read / write transaction is completed.</p> <p>Read Transaction: This bit is set at the falling edge of Read Transfer Active Status.</p> <p>There are two cases in which the Interrupt is generated. The first is when a data transfer is completed as specified by data length (After the last data has been read to the Host System). The second is when data has stopped at the block gap and completed the data transfer by setting the Stop At Block Gap Request in the Block Gap Control Register (After valid data has been read to the Host System).</p> <p>Write Transaction: This bit is set at the falling edge of the DAT Line Active Status.</p> <p>There are two cases in which the Interrupt is generated. The first is when the last data is written to the card as specified by data length and Busy signal is released. The second is when data transfers are stopped at the block gap by setting Stop At Block Gap Request in the Block Gap Control Register and data transfers completed. (After valid data is written to the SD card and the busy signal is released).</p> <p>Note: Transfer Complete has higher priority than Data Timeout Error. If both bits are set to 1, the data transfer can be considered complete 0 - No Data Transfer Complete 1 - Data Transfer Complete</p> |
| Command_Complete | 0 | wtc | 0x0 | <p>This bit is set when get the end bit of the command response (Except Auto CMD12).</p> <p>Note: Command Timeout Error has higher priority than Command Complete. If both are set to 1, it can be considered that the response was not received correctly.</p> <p>0 - No Command Complete 1 - Command Complete</p> |

Register ([sdio](#))

Normal_interrupt_status_enable_Error_interrupt_status_enable

Name Normal_interrupt_status_enable_Error_interrupt_status_enable

Relative Address 0x00000034

Absolute Address sd0: 0xE0100034
sd1: 0xE0101034

Width 30 bits

Access Type mixed
 Reset Value 0x00000000
 Description Normal interrupt status enable register
 Error interrupt status enable register

Register Normal_interrupt_status_enable_Error_interrupt_status_enable Details

| Field Name | Bits | Type | Reset Value | Description |
|-------------------------------------|-------|------|-------------|---|
| Ceata_Error_Status_Enable | 29 | rw | 0x0 | 0 - Masked 1 - Enabled |
| Target_Response_Error_Status_Enable | 28 | rw | 0x0 | 0 - Masked 1 - Enabled |
| reserved | 27:26 | ro | 0x0 | Reserved |
| ADMA_Error_Status_Enable | 25 | rw | 0x0 | 0 - Masked 1 - Enabled |
| Auto_CMD12_Error_Status_Enable | 24 | rw | 0x0 | 0 - Masked 1 - Enabled |
| Current_Limit_Error_Status_Enable | 23 | rw | 0x0 | 0 - Masked 1 - Enabled |
| Data_End_Bit_Error_Status_Enable | 22 | rw | 0x0 | 0 - Masked 1 - Enabled |
| Data_CRC_Error_Status_Enable | 21 | rw | 0x0 | 0 - Masked 1 - Enabled |
| Data_Timeout_Error_Status_Enable | 20 | rw | 0x0 | 0 - Masked 1 - Enabled |
| Command_Index_Error_Status_Enable | 19 | rw | 0x0 | 0 - Masked 1 - Enabled |
| Command_End_Bit_Error_Status_Enable | 18 | rw | 0x0 | 0 - Masked 1 - Enabled |
| Command_CRC_Error_Status_Enable | 17 | rw | 0x0 | 0 - Masked 1 - Enabled |
| Command_Timeout_Error_Status_Enable | 16 | rw | 0x0 | 0 - Masked 1 - Enabled |
| Fixed_to_0 | 15 | ro | 0x0 | The HC shall control error Interrupts using the Error Interrupt Status Enable register. |
| reserved | 14:11 | ro | 0x0 | Reserved |
| Boot_terminate_Interrupt_enable | 10 | rw | 0x0 | 0 - Masked 1 - Enabled |
| Boot_ack_rcv_enable | 9 | rw | 0x0 | 0 - Masked 1 - Enabled |

| Field Name | Bits | Type | Reset Value | Description |
|----------------------------------|------|------|-------------|--|
| Card_Interrupt_Status_Enable | 8 | rw | 0x0 | If this bit is set to 0, the HC shall clear Interrupt request to the System. The Card Interrupt detection is stopped when this bit is cleared and restarted when this bit is set to 1. The HD should clear the Card Interrupt Status Enable before servicing the Card Interrupt and should set this bit again after all Interrupt requests from the card are cleared to prevent inadvertent Interrupts. 0 - Masked 1 - Enabled |
| Card_Removal_Status_Enable | 7 | rw | 0x0 | 0 - Masked 1 - Enabled |
| Card_Insertion_Status_Enable | 6 | rw | 0x0 | 0 - Masked 1 - Enabled |
| Buffer_Read_Ready_Status_Enable | 5 | rw | 0x0 | 0 - Masked 1 - Enabled |
| Buffer_Write_Ready_Status_Enable | 4 | rw | 0x0 | 0 - Masked 1 - Enabled |
| DMA_Interrupt_Status_Enable | 3 | rw | 0x0 | 0 - Masked 1 - Enabled |
| Block_Gap_Event_Status_Enable | 2 | rw | 0x0 | 0 - Masked 1 - Enabled |
| Transfer_Complete_Status_Enable | 1 | rw | 0x0 | 0 - Masked 1 - Enabled |
| Command_Complete_Status_Enable | 0 | rw | 0x0 | 0 - Masked 1 - Enabled |

Register ([sdio](#))

Normal_interrupt_signal_enable_Error_interrupt_signal_enable

| | |
|------------------|---|
| Name | Normal_interrupt_signal_enable_Error_interrupt_signal_enable |
| Relative Address | 0x00000038 |
| Absolute Address | sd0: 0xE0100038 sd1: 0xE0101038 |
| Width | 30 bits |
| Access Type | mixed |
| Reset Value | 0x00000000 |
| Description | Normal interrupt signal enable register Error interrupt signal enable register |

Register Normal_interrupt_signal_enable_Error_interrupt_signal_enable Details

| Field Name | Bits | Type | Reset Value | Description |
|--|-------|------|-------------|---|
| Ceata_Error_Signal_Enable | 29 | rw | 0x0 | 0 - Masked 1 - Enabled |
| Target_Response_Error_Signal_Enable | 28 | rw | 0x0 | 0 - Masked 1 - Enabled |
| reserved | 27:26 | ro | 0x0 | Reserved |
| ADMA_Error_Signal_Enable | 25 | rw | 0x0 | 0 - Masked 1 - Enabled |
| Auto_CMD12_Error_Signal_Enable | 24 | rw | 0x0 | 0 - Masked 1 - Enabled |
| Current_Limit_Error_Signal_Enable | 23 | rw | 0x0 | 0 - Masked 1 - Enabled |
| Data_End_Bit_Error_Signal_Enable | 22 | rw | 0x0 | 0 - Masked 1 - Enabled |
| Data_CRC_Error_Signal_Enable | 21 | rw | 0x0 | 0 - Masked 1 - Enabled |
| Data_Timeout_Error_Signal_Enable | 20 | rw | 0x0 | 0 - Masked 1 - Enabled |
| Command_Index_Error_Signal_Enable | 19 | rw | 0x0 | 0 - Masked 1 - Enabled |
| Command_End_Bit_Error_Signal_Enable | 18 | rw | 0x0 | 0 - Masked 1 - Enabled |
| Command_CRC_Error_Signal_Enable | 17 | rw | 0x0 | 0 - Masked 1 - Enabled |
| Command_Timeout_Error_Signal_Enable | 16 | rw | 0x0 | 0 - Masked 1 - Enabled |
| Fixed_to_0 | 15 | ro | 0x0 | The HD shall control error Interrupts using the Error Interrupt Signal Enable register. |
| reserved | 14:11 | ro | 0x0 | Reserved |
| Boot_terminate_Interrupt_signal_enable | 10 | rw | 0x0 | 0 - Masked 1 - Enabled |
| Boot_ack_rcv_signal_enable | 9 | rw | 0x0 | 0 - Masked 1 - Enabled |
| Card_Interrupt_Signal_Enable | 8 | rw | 0x0 | 0 - Masked 1 - Enabled |
| Card_Removal_Signal_Enable | 7 | rw | 0x0 | 0 - Masked 1 - Enabled |
| Card_Insertion_Signal_Enable | 6 | rw | 0x0 | 0 - Masked 1 - Enabled |

| Field Name | Bits | Type | Reset Value | Description |
|----------------------------------|------|------|-------------|---------------------------|
| Buffer_Read_Ready_Signal_Enable | 5 | rw | 0x0 | 0 - Masked 1 - Enabled |
| Buffer_Write_Ready_Signal_Enable | 4 | rw | 0x0 | 0 - Masked 1 - Enabled |
| DMA_Interrupt_Signal_Enable | 3 | rw | 0x0 | 0 - Masked 1 - Enabled |
| Block_Gap_Event_Signal_Enable | 2 | rw | 0x0 | 0 - Masked 1 - Enabled |
| Transfer_Complete_Signal_Enable | 1 | rw | 0x0 | 0 - Masked 1 - Enabled |
| Command_Complete_Signal_Enable | 0 | rw | 0x0 | 0 - Masked 1 - Enabled |

Register ([sdio](#)) Auto_CMD12_error_status

| | |
|------------------|------------------------------------|
| Name | Auto_CMD12_error_status |
| Relative Address | 0x0000003C |
| Absolute Address | sd0: 0xE010003C sd1: 0xE010103C |
| Width | 8 bits |
| Access Type | ro |
| Reset Value | 0x00000000 |
| Description | Auto CMD12 error status register |

Register Auto_CMD12_error_status Details

When Auto CMD12 Error Status is set, the HD shall check this register to identify what kind of error Auto CMD12 indicated. This register is valid only when the Auto CMD12 Error is set.

| Field Name | Bits | Type | Reset Value | Description |
|--|------|------|-------------|---|
| Command_Not_Issued_By_Auto_CMD12_Error | 7 | ro | 0x0 | Setting this bit to 1 means CMD_wo_DAT is not executed due to an Auto CMD12 error (D04 - D01) in this register. 0 - No Error 1 - Not Issued |
| reserved | 6:5 | ro | 0x0 | Reserved |
| Auto_CMD12_Index_Error | 4 | ro | 0x0 | Occurs if the Command Index error occurs in response to a command. 0 - No Error 1 - Error |

| Field Name | Bits | Type | Reset Value | Description |
|--------------------------|------|------|-------------|---|
| Auto_CMD12_End_Bit_Error | 3 | ro | 0x0 | Occurs when detecting that the end bit of command response is 0. 0 - No Error 1 - End Bit Error Generated |
| Auto_CMD12_CRC_Error | 2 | ro | 0x0 | Occurs when detecting a CRC error in the command response. 0 - No Error 1 - CRC Error Generated |
| Auto_CMD12_Timeout_Error | 1 | ro | 0x0 | Occurs if the no response is returned within 64 SDCLK cycles from the end bit of the command. If this bit is set to 1, the other error status bits (D04 - D02) are meaningless. 0 - No Error 1 - Timeout |
| Auto_CMD12_not_Executed | 0 | ro | 0x0 | If memory multiple block data transfer is not started due to command error, this bit is not set because it is not necessary to issue Auto CMD12. Setting this bit to 1 means the HC cannot issue Auto CMD12 to stop memory multiple block transfer due to some error. If this bit is set to 1, other error status bits (D04 - D01) are meaningless. 0 - Executed 1 - Not Executed |

Register ([sdio](#)) Capabilities

| | |
|------------------|------------------------------------|
| Name | Capabilities |
| Relative Address | 0x00000040 |
| Absolute Address | sd0: 0xE0100040 sd1: 0xE0101040 |
| Width | 31 bits |
| Access Type | ro |
| Reset Value | 0x69EC0080 |
| Description | Capabilities register |

Register Capabilities Details

This register provides the HD with information specific to the HC implementation. The HC may implement these values as fixed or loaded from flash memory during power on initialization.

| Field Name | Bits | Type | Reset Value | Description |
|----------------------------|------|------|-------------|--|
| Spi_block_mode | 30 | ro | 0x1 | Spi block mode 0 - Not Supported 1 - Supported |
| Spi_mode | 29 | ro | 0x1 | Spi mode 0 - Not Supported 1 - Supported |
| 64_bit_System_Bus_Support | 28 | ro | 0x0 | 1 - supports 64 bit system address 0 - Does not support 64 bit system address |
| Interrupt_mode | 27 | ro | 0x1 | Interrupt mode 0 - Not Supported 1 - Supported |
| Voltage_Support_1_8_V | 26 | ro | 0x0 | 0 - 1.8 V Not Supported 1 - 1.8 V Supported |
| Voltage_Support_3_0_V | 25 | ro | 0x0 | 0 - 3.0 V Not Supported 1 - 3.0 V Supported |
| Voltage_Support_3_3_V | 24 | ro | 0x1 | 0 - 3.3 V Not Supported 1 - 3.3 V Supported |
| Suspend_Resume_Support | 23 | ro | 0x1 | This bit indicates whether the HC supports Suspend / Resume functionality. If this bit is 0, the Suspend and Resume mechanism are not supported and the HD shall not issue either Suspend / Resume commands. 0 - Not Supported 1 - Supported |
| SDMA_Support | 22 | ro | 0x1 | This bit indicates whether the HC is capable of using DMA to transfer data between system memory and the HC directly. 0 - SDMA Not Supported 1 - SDMA Supported. |
| High_Speed_Support | 21 | ro | 0x1 | This bit indicates whether the HC and the Host System support High Speed mode and they can supply SD Clock frequency from 25Mhz to 50 MHz (for SD)/ 20MHz to 52MHz (for MMC). 0 - High Speed Not Supported 1 - High Speed Supported |
| reserved | 20 | ro | 0x0 | Reserved |
| ADMA2_Support | 19 | ro | 0x1 | 1 - ADMA2 support. 0 - ADMA2 not support |
| Extended_Media_Bus_Support | 18 | ro | 0x1 | This bit indicates whether the Host Controller is capable bus. 1 - Extended Media Bus Supported 0 - Extended Media Bus not Supported |

| Field Name | Bits | Type | Reset Value | Description |
|--------------------|-------|------|-------------|--|
| Max_Block_Length | 17:16 | ro | 0x0 | This value indicates the maximum block size that the HD can read and write to the buffer in the HC. The buffer shall transfer this block size without wait cycles. Three sizes can be defined as indicated below. 00 - 512 byte 01 - 1024 byte 10 - 2048 byte 11 - 4096 byte |
| reserved | 15:14 | ro | 0x0 | Reserved |
| reserved | 13:8 | ro | 0x0 | Reserved. Do not modify. |
| Timeout_Clock_Unit | 7 | ro | 0x1 | This bit shows the unit of base clock frequency used to detect Data Timeout Error. 0 - KHz 1 - MHz |
| reserved | 6 | ro | 0x0 | Reserved |
| reserved | 5:0 | ro | 0x0 | Reserved. Do not modify. |

Register ([sdio](#)) Maximum_current_capabilities

| | |
|------------------|---------------------------------------|
| Name | Maximum_current_capabilities |
| Relative Address | 0x00000048 |
| Absolute Address | sd0: 0xE0100048 sd1: 0xE0101048 |
| Width | 24 bits |
| Access Type | ro |
| Reset Value | 0x00000001 |
| Description | Maximum current capabilities register |

Register Maximum_current_capabilities Details

| Field Name | Bits | Type | Reset Value | Description |
|--------------------------|-------|------|-------------|--------------------------|
| Maximum_Current_for_1_8V | 23:16 | ro | 0x0 | Maximum Current for 1.8V |
| Maximum_Current_for_3_0V | 15:8 | ro | 0x0 | Maximum Current for 3.0V |
| Maximum_Current_for_3_3V | 7:0 | ro | 0x1 | Maximum Current for 3.3V |

Register ([sdio](#))

Force_event_for_AutoCmd12_Error_Status_Force_event_register_for_error_interrupt_status

| | |
|------------------|--|
| Name | Force_event_for_AutoCmd12_Error_Status_Force_event_register_for_error_interrupt_status |
| Relative Address | 0x00000050 |
| Absolute Address | sd0: 0xE0100050 sd1: 0xE0101050 |
| Width | 32 bits |
| Access Type | mixed |
| Reset Value | 0x00000000 |
| Description | Force event register for Auto CMD12 error status register Force event register for error interrupt status |

Register

Force_event_for_AutoCmd12_Error_Status_Force_event_register_for_error_interrupt_status Details

The Force Event Register is not a physically implemented register. Rather, it is an address at which the Auto CMD12 Error Status Register can be written.

Writing 1:set each bit of the Auto CMD12 Error Status Register

Writing 0:no effect.

The Force Event Register is not a physically implemented register. Rather, it is an address at which the Error Interrupt Status register can be written. The effect of a write to this address will be reflected in the Error Interrupt Status Register if the corresponding bit of the Error Interrupt Status Enable Register is set.

Writing 1:set each bit of the Error Interrupt Status Register

Writing 0:no effect

| Field Name | Bits | Type | Reset Value | Description |
|--|-------|------|-------------|---|
| Force_Event_for_Vendor_Specific_Error_Status | 31:30 | wo | 0x0 | Additional status bits can be defined in this register by the vendor. 1 - Interrupt is generated 0 - No interrupt |
| Force_Event_for_Ceata_error | 29 | wo | 0x0 | Force Event for Ceata Error 1 - Interrupt is generated 0 - No interrupt |
| Force_event_for_Target_Response_error | 28 | wo | 0x0 | Force Event for Target Response Error 1 - Interrupt is generated 0 - No interrupt |

| Field Name | Bits | Type | Reset Value | Description |
|--|-------|------|-------------|---|
| reserved | 27:26 | ro | 0x0 | Reserved |
| Force_Event_for_ADMA_Error | 25 | wo | 0x0 | Force Event for ADMA Error 1 - Interrupt is generated 0 - No interrupt |
| Force_Event_for_Auto_CMD12_Error | 24 | wo | 0x0 | Force Event for Auto CMD12 Error 1 - Interrupt is generated 0 - No interrupt |
| Force_Event_for_Current_Limit_Error | 23 | wo | 0x0 | Force Event for Current Limit Error 1 - Interrupt is generated 0 - No interrupt |
| Force_Event_for_Data_End_Bit_Error | 22 | wo | 0x0 | Force Event for Data End Bit Error 1 - Interrupt is generated 0 - No interrupt |
| Force_Event_for_Data_CRC_Error | 21 | wo | 0x0 | Force Event for Data CRC Error 1 - Interrupt is generated 0 - No interrupt |
| Force_Event_for_Data_Timeout_Error | 20 | wo | 0x0 | Force Event for Data Timeout Error 1 - Interrupt is generated 0 - No interrupt |
| Force_Event_for_Command_Index_Error | 19 | wo | 0x0 | Force Event for Command Index Error 1 - Interrupt is generated 0 - No interrupt |
| Force_Event_for_Command_End_Bit_Error | 18 | wo | 0x0 | Force Event for Command End Bit Error 1 - Interrupt is generated 0 - No interrupt |
| Force_Event_for_Command_CRC_Error | 17 | wo | 0x0 | Force Event for Command CRC Error 1 - Interrupt is generated 0 - No interrupt |
| Force_Event_for_Command_Timeout_Error | 16 | wo | 0x0 | Force Event for Command Timeout Error 1 - Interrupt is generated 0 - No interrupt |
| reserved | 15:8 | ro | 0x0 | Reserved |
| Force_Event_for_command_not_issued_by_Auto_CMD12_Error | 7 | wo | 0x0 | 1 - Interrupt is generated 0 - no interrupt |
| reserved | 6:5 | ro | 0x0 | Reserved |
| Force_Event_for_Auto_CMD12_Index_Error | 4 | wo | 0x0 | 1 - Interrupt is generated 0 - no interrupt |
| Force_Event_for_Auto_CMD12_End_bit_Error | 3 | wo | 0x0 | 1 - Interrupt is generated 0 - no interrupt |
| Force_Event_for_Auto_CMD12_CRC_Error | 2 | wo | 0x0 | 1 - Interrupt is generated 0 - no interrupt |

| Field Name | Bits | Type | Reset Value | Description |
|--|------|------|-------------|--|
| Force_Event_for_Auto_CMD12_timeout_Error | 1 | wo | 0x0 | 1 - Interrupt is generated 0 - no interrupt |
| Force_Event_for_Auto_CMD12_NOT_Executed | 0 | wo | 0x0 | 1 - Interrupt is generated 0 - no interrupt |

Register ([sdio](#)) ADMA_error_status

| | |
|------------------|------------------------------------|
| Name | ADMA_error_status |
| Relative Address | 0x00000054 |
| Absolute Address | sd0: 0xE0100054 sd1: 0xE0101054 |
| Width | 3 bits |
| Access Type | mixed |
| Reset Value | 0x00000000 |
| Description | ADMA error status register |

Register ADMA_error_status Details

When ADMA Error Interrupt occurs, the ADMA Error States field in this register holds the ADMA state and the ADMA System Address Register holds the address around the error descriptor.

| Field Name | Bits | Type | Reset Value | Description |
|----------------------------|------|------|-------------|---|
| ADMA_Length_Mismatch_Error | 2 | wtc | 0x0 | This error occurs in the following 2 cases. 1. While Block Count Enable being set, the total data length specified by the Descriptor table is different from that specified by the Block Count and Block Length. 2. Total data length can not be divided by the block length. 1 - Error 0 - No error |
| ADMA_Error_State | 1:0 | ro | 0x0 | This field indicates the state of ADMA when error is occurred during ADMA data transfer. This field never indicates "10" because ADMA never stops in this state. D01 - D00 : ADMA Error State when error is occurred Contents of SYS_SDR register 00 - ST_STOP (Stop DMA) Points next of the error descriptor 01 - ST_FDS (Fetch Descriptor) Points the error descriptor 10 - Never set this state (Not used) 11 - ST_TFR (Transfer Data) Points the next of the error descriptor |

Register ([sdio](#)) ADMA_system_address

Name ADMA_system_address
 Relative Address 0x00000058
 Absolute Address sd0: 0xE0100058
 sd1: 0xE0101058
 Width 32 bits
 Access Type rw
 Reset Value 0x00000000
 Description ADMA system address register

Register ADMA_system_address Details

| Field Name | Bits | Type | Reset Value | Description |
|---------------------|------|------|-------------|--|
| ADMA_System_Address | 31:0 | rw | 0x0 | <p>This register holds byte address of executing command of the Descriptor table. 32-bit Address Descriptor uses lower 32-bit of this register. At the start of ADMA, the Host Driver shall set start address of the Descriptor table. The ADMA increments this register address, which points to next line, when every fetching a Descriptor line. When the ADMA Error Interrupt is generated, this register shall hold valid Descriptor address depending on the ADMA state. The Host Driver shall program Descriptor Table on 32-bit boundary and set 32-bit boundary address to this register. ADMA2 ignores lower 2-bit of this register and assumes it to be 00b.</p> <p>32-bit Address ADMA Register Value 32-bit System Address 0x00000000 0x00000000 0x00000004 0x00000004 to 0xFFFFFFFFC 0xFFFFFFFFC</p> |

Register ([sdio](#)) Boot_Timeout_control

| | |
|------------------|------------------------------------|
| Name | Boot_Timeout_control |
| Relative Address | 0x00000060 |
| Absolute Address | sd0: 0xE0100060 sd1: 0xE0101060 |
| Width | 32 bits |
| Access Type | rw |
| Reset Value | 0x00000000 |
| Description | Boot Timeout control register |

Register Boot_Timeout_control Details

| Field Name | Bits | Type | Reset Value | Description |
|---------------------------------|------|------|-------------|--|
| Boot_Data_Timeout_Counter_Value | 31:0 | rw | 0x0 | This value determines the interval by which DAT line time-outs are detected during boot operation for MMC3.31 card. The value is in number of sd clock. |

Register ([sdio](#)) Debug_Selection

| | |
|------------------|------------------------------------|
| Name | Debug_Selection |
| Relative Address | 0x00000064 |
| Absolute Address | sd0: 0xE0100064 sd1: 0xE0101064 |
| Width | 1 bits |
| Access Type | wo |
| Reset Value | 0x00000000 |
| Description | Debug Selection Register |

Register Debug_Selection Details

| Field Name | Bits | Type | Reset Value | Description |
|------------|------|------|-------------|---|
| Debug_sel | 0 | wo | 0x0 | 1- cmd register, Interrupt status, transmitter module, ahb_iface module and clk sdcard signals are probed out. 0 - receiver module and fifo_ctrl module signals are probed out |

Register ([sdio](#)) SPI_interrupt_support

| | |
|------------------|------------------------------------|
| Name | SPI_interrupt_support |
| Relative Address | 0x000000F0 |
| Absolute Address | sd0: 0xE01000F0 sd1: 0xE01010F0 |
| Width | 8 bits |
| Access Type | rw |
| Reset Value | 0x00000000 |
| Description | SPI interrupt support register |

Register SPI_interrupt_support Details

| Field Name | Bits | Type | Reset Value | Description |
|-----------------|------|------|-------------|--|
| SPI_INT_SUPPORT | 7:0 | rw | 0x0 | This bit is set to indicate the assertion of interrupts in the SPI mode at any time, irrespective of the status of the card select (CS) line. If this bit is zero, then SDIO card can only assert the interrupt line in the SPI mode when the CS line is asserted. |

Register ([sdio](#)) Slot_interrupt_status_Host_controller_version

| | |
|------------------|---|
| Name | Slot_interrupt_status_Host_controller_version |
| Relative Address | 0x000000FC |
| Absolute Address | sd0: 0xE01000FC sd1: 0xE01010FC |
| Width | 32 bits |
| Access Type | ro |
| Reset Value | 0x89010000 |
| Description | Slot interrupt status register and Host controller version register |

Register Slot_interrupt_status_Host_controller_version Details

| Field Name | Bits | Type | Reset Value | Description |
|------------------------------|-------|------|-------------|---|
| Vendor_Version_Number | 31:24 | ro | 0x89 | This status is reserved for the vendor version number. The HD should not use this status. |
| Specification_Version_Number | 23:16 | ro | 0x1 | This status indicates the Host Controller Spec. Version. The upper and lower 4-bits indicate the version. 00 - SD Host Specification version 1.0 01 - SD Host Specification version 2.00 including only the feature of the Test Register others - Reserved |

| Field Name | Bits | Type | Reset Value | Description |
|--------------------------------|------|------|-------------|--|
| reserved | 15:8 | ro | 0x0 | Reserved |
| Interrupt_Signal_for_Each_Slot | 7:0 | ro | 0x0 | <p>These status bit indicate the logical OR of Interrupt signal and Wakeup signal for each slot. A maximum of 8 slots can be defined. If one interrupt signal is associated with multiple slots. the HD can know which interrupt is generated by reading these status bits. By a power on reset or by Software Reset For All, the Interrupt signal shall be de asserted and this status shall read 00h.</p> <p>Bit 00 - Slot 1 Bit 01 - Slot 2 Bit 02 - Slot 3 ----- Bit 07 - Slot 8</p> |

B.28 System Level Control Registers (slcr)

| | |
|--------------|---------------------------------------|
| Module Name | System Level Control Registers (slcr) |
| Base Address | 0xF8000000 slcr |
| Description | System Level Control Registers |
| Vendor Info | Xilinx Zynq slcr |

Register Summary

| Register Name | Address | Width | Type | Reset Value | Description |
|--------------------------------|------------|-------|------|-------------|---------------------------------------|
| SCL | 0x00000000 | 32 | rw | 0x00000000 | Secure Configuration Lock |
| SLCR_LOCK | 0x00000004 | 32 | wo | 0x00000000 | SLCR Write Protection Lock |
| SLCR_UNLOCK | 0x00000008 | 32 | wo | 0x00000000 | SLCR Write Protection Unlock |
| SLCR_LOCKSTA | 0x0000000C | 32 | ro | 0x00000001 | SLCR Write Protection Status |
| ARM_PLL_CTRL | 0x00000100 | 32 | rw | 0x0001A008 | Arm PLL Control |
| DDR_PLL_CTRL | 0x00000104 | 32 | rw | 0x0001A008 | DDR PLL Control |
| IO_PLL_CTRL | 0x00000108 | 32 | rw | 0x0001A008 | IO PLL Control |
| PLL_STATUS | 0x0000010C | 32 | ro | 0x0000003F | PLL Status |
| ARM_PLL_CFG | 0x00000110 | 32 | rw | 0x00177EA0 | Arm PLL Configuration |
| DDR_PLL_CFG | 0x00000114 | 32 | rw | 0x00177EA0 | DDR PLL Configuration |
| IO_PLL_CFG | 0x00000118 | 32 | rw | 0x00177EA0 | IO PLL Configuration |
| ARM_CLK_CTRL | 0x00000120 | 32 | rw | 0x1F000400 | CPU Clock Control |
| DDR_CLK_CTRL | 0x00000124 | 32 | rw | 0x18400003 | DDR Clock Control |
| DCI_CLK_CTRL | 0x00000128 | 32 | rw | 0x01E03201 | DCI clock control |
| APER_CLK_CTRL | 0x0000012C | 32 | rw | 0x01FFCCCD | AMBA Peripheral Clock Control |
| USB0_CLK_CTRL | 0x00000130 | 32 | rw | 0x00101941 | USB 0 ULPI Clock Control |
| USB1_CLK_CTRL | 0x00000134 | 32 | rw | 0x00101941 | USB 1 ULPI Clock Control |
| GEM0_RCLK_CTRL | 0x00000138 | 32 | rw | 0x00000001 | GigE 0 Rx Clock and Rx Signals Select |
| GEM1_RCLK_CTRL | 0x0000013C | 32 | rw | 0x00000001 | GigE 1 Rx Clock and Rx Signals Select |
| GEM0_CLK_CTRL | 0x00000140 | 32 | rw | 0x00003C01 | GigE 0 Ref Clock Control |
| GEM1_CLK_CTRL | 0x00000144 | 32 | rw | 0x00003C01 | GigE 1 Ref Clock Control |
| SMC_CLK_CTRL | 0x00000148 | 32 | rw | 0x00003C21 | SMC Ref Clock Control |
| LQSPI_CLK_CTRL | 0x0000014C | 32 | rw | 0x00002821 | Quad SPI Ref Clock Control |
| SDIO_CLK_CTRL | 0x00000150 | 32 | rw | 0x00001E03 | SDIO Ref Clock Control |
| UART_CLK_CTRL | 0x00000154 | 32 | rw | 0x00003F03 | UART Ref Clock Control |

| Register Name | Address | Width | Type | Reset Value | Description |
|---------------------------------|------------|-------|------|-------------|------------------------------------|
| SPI_CLK_CTRL | 0x00000158 | 32 | rw | 0x00003F03 | SPI Ref Clock Control |
| CAN_CLK_CTRL | 0x0000015C | 32 | rw | 0x00501903 | CAN Ref Clock Control |
| CAN_MIOCLK_CTRL | 0x00000160 | 32 | rw | 0x00000000 | CAN MIO Clock Control |
| DBG_CLK_CTRL | 0x00000164 | 32 | rw | 0x00000F03 | SoC Debug Clock Control |
| PCAP_CLK_CTRL | 0x00000168 | 32 | rw | 0x00000F01 | PCAP Clock Control |
| TOPSW_CLK_CTRL | 0x0000016C | 32 | rw | 0x00000000 | Central Interconnect Clock Control |
| FPGA0_CLK_CTRL | 0x00000170 | 32 | rw | 0x00101800 | PL Clock 0 Output control |
| FPGA0_THR_CTRL | 0x00000174 | 32 | rw | 0x00000000 | PL Clock 0 Throttle control |
| FPGA0_THR_CNT | 0x00000178 | 32 | rw | 0x00000000 | PL Clock 0 Throttle Count control |
| FPGA0_THR_STA | 0x0000017C | 32 | ro | 0x00010000 | PL Clock 0 Throttle Status read |
| FPGA1_CLK_CTRL | 0x00000180 | 32 | rw | 0x00101800 | PL Clock 1 Output control |
| FPGA1_THR_CTRL | 0x00000184 | 32 | rw | 0x00000000 | PL Clock 1 Throttle control |
| FPGA1_THR_CNT | 0x00000188 | 32 | rw | 0x00000000 | PL Clock 1 Throttle Count |
| FPGA1_THR_STA | 0x0000018C | 32 | ro | 0x00010000 | PL Clock 1 Throttle Status control |
| FPGA2_CLK_CTRL | 0x00000190 | 32 | rw | 0x00101800 | PL Clock 2 output control |
| FPGA2_THR_CTRL | 0x00000194 | 32 | rw | 0x00000000 | PL Clock 2 Throttle Control |
| FPGA2_THR_CNT | 0x00000198 | 32 | rw | 0x00000000 | PL Clock 2 Throttle Count |
| FPGA2_THR_STA | 0x0000019C | 32 | ro | 0x00010000 | PL Clock 2 Throttle Status |
| FPGA3_CLK_CTRL | 0x000001A0 | 32 | rw | 0x00101800 | PL Clock 3 output control |
| FPGA3_THR_CTRL | 0x000001A4 | 32 | rw | 0x00000000 | PL Clock 3 Throttle Control |
| FPGA3_THR_CNT | 0x000001A8 | 32 | rw | 0x00000000 | PL Clock 3 Throttle Count |
| FPGA3_THR_STA | 0x000001AC | 32 | ro | 0x00010000 | PL Clock 3 Throttle Status |
| CLK_621_TRUE | 0x000001C4 | 32 | rw | 0x00000001 | CPU Clock Ratio Mode select |
| PSS_RST_CTRL | 0x00000200 | 32 | rw | 0x00000000 | PS Software Reset Control |
| DDR_RST_CTRL | 0x00000204 | 32 | rw | 0x00000000 | DDR Software Reset Control |
| TOPSW_RST_CTRL | 0x00000208 | 32 | rw | 0x00000000 | Central Interconnect Reset Control |
| DMAC_RST_CTRL | 0x0000020C | 32 | rw | 0x00000000 | DMAC Software Reset Control |
| USB_RST_CTRL | 0x00000210 | 32 | rw | 0x00000000 | USB Software Reset Control |
| GEM_RST_CTRL | 0x00000214 | 32 | rw | 0x00000000 | Gigabit Ethernet SW Reset Control |
| SDIO_RST_CTRL | 0x00000218 | 32 | rw | 0x00000000 | SDIO Software Reset Control |
| SPI_RST_CTRL | 0x0000021C | 32 | rw | 0x00000000 | SPI Software Reset Control |
| CAN_RST_CTRL | 0x00000220 | 32 | rw | 0x00000000 | CAN Software Reset Control |
| I2C_RST_CTRL | 0x00000224 | 32 | rw | 0x00000000 | I2C Software Reset Control |

| Register Name | Address | Width | Type | Reset Value | Description |
|----------------------------------|------------|-------|-------|-------------|---------------------------------------|
| UART_RST_CTRL | 0x00000228 | 32 | rw | 0x00000000 | UART Software Reset Control |
| GPIO_RST_CTRL | 0x0000022C | 32 | rw | 0x00000000 | GPIO Software Reset Control |
| LQSPI_RST_CTRL | 0x00000230 | 32 | rw | 0x00000000 | Quad SPI Software Reset Control |
| SMC_RST_CTRL | 0x00000234 | 32 | rw | 0x00000000 | SMC Software Reset Control |
| OCM_RST_CTRL | 0x00000238 | 32 | rw | 0x00000000 | OCM Software Reset Control |
| FPGA_RST_CTRL | 0x00000240 | 32 | rw | 0x01F33F0F | FPGA Software Reset Control |
| A9_CPU_RST_CTRL | 0x00000244 | 32 | rw | 0x00000000 | CPU Reset and Clock control |
| RS_AWDT_CTRL | 0x0000024C | 32 | rw | 0x00000000 | Watchdog Timer Reset Control |
| REBOOT_STATUS | 0x00000258 | 32 | rw | 0x00400000 | Reboot Status, persistent |
| BOOT_MODE | 0x0000025C | 32 | mixed | x | Boot Mode Strapping Pins |
| APU_CTRL | 0x00000300 | 32 | rw | 0x00000000 | APU Control |
| WDT_CLK_SEL | 0x00000304 | 32 | rw | 0x00000000 | SWDT clock source select |
| TZ_DMA_NS | 0x00000440 | 32 | rw | 0x00000000 | DMAC TrustZone Config |
| TZ_DMA_IRQ_NS | 0x00000444 | 32 | rw | 0x00000000 | DMAC TrustZone Config for Interrupts |
| TZ_DMA_PERIPH_NS | 0x00000448 | 32 | rw | 0x00000000 | DMAC TrustZone Config for Peripherals |
| PSS_IDCODE | 0x00000530 | 32 | ro | x | PS IDCODE |
| DDR_URGENT | 0x00000600 | 32 | rw | 0x00000000 | DDR Urgent Control |
| DDR_CAL_START | 0x0000060C | 32 | mixed | 0x00000000 | DDR Calibration Start Triggers |
| DDR_REF_START | 0x00000614 | 32 | mixed | 0x00000000 | DDR Refresh Start Triggers |
| DDR_CMD_STA | 0x00000618 | 32 | mixed | 0x00000000 | DDR Command Store Status |
| DDR_URGENT_SEL | 0x0000061C | 32 | rw | 0x00000000 | DDR Urgent Select |
| DDR_DFI_STATUS | 0x00000620 | 32 | mixed | 0x00000000 | DDR DFI status |
| MIO_PIN_00 | 0x00000700 | 32 | rw | 0x00001601 | MIO Pin 0 Control |
| MIO_PIN_01 | 0x00000704 | 32 | rw | 0x00001601 | MIO Pin 1 Control |
| MIO_PIN_02 | 0x00000708 | 32 | rw | 0x00000601 | MIO Pin 2 Control |
| MIO_PIN_03 | 0x0000070C | 32 | rw | 0x00000601 | MIO Pin 3 Control |
| MIO_PIN_04 | 0x00000710 | 32 | rw | 0x00000601 | MIO Pin 4 Control |
| MIO_PIN_05 | 0x00000714 | 32 | rw | 0x00000601 | MIO Pin 5 Control |
| MIO_PIN_06 | 0x00000718 | 32 | rw | 0x00000601 | MIO Pin 6 Control |
| MIO_PIN_07 | 0x0000071C | 32 | rw | 0x00000601 | MIO Pin 7 Control |
| MIO_PIN_08 | 0x00000720 | 32 | rw | 0x00000601 | MIO Pin 8 Control |
| MIO_PIN_09 | 0x00000724 | 32 | rw | 0x00001601 | MIO Pin 9 Control |
| MIO_PIN_10 | 0x00000728 | 32 | rw | 0x00001601 | MIO Pin 10 Control |
| MIO_PIN_11 | 0x0000072C | 32 | rw | 0x00001601 | MIO Pin 11 Control |
| MIO_PIN_12 | 0x00000730 | 32 | rw | 0x00001601 | MIO Pin 12 Control |

| Register Name | Address | Width | Type | Reset Value | Description |
|----------------------------|------------|-------|------|-------------|--------------------|
| MIO_PIN_13 | 0x00000734 | 32 | rw | 0x00001601 | MIO Pin 13 Control |
| MIO_PIN_14 | 0x00000738 | 32 | rw | 0x00001601 | MIO Pin 14 Control |
| MIO_PIN_15 | 0x0000073C | 32 | rw | 0x00001601 | MIO Pin 15 Control |
| MIO_PIN_16 | 0x00000740 | 32 | rw | 0x00001601 | MIO Pin 16 Control |
| MIO_PIN_17 | 0x00000744 | 32 | rw | 0x00001601 | MIO Pin 17 Control |
| MIO_PIN_18 | 0x00000748 | 32 | rw | 0x00001601 | MIO Pin 18 Control |
| MIO_PIN_19 | 0x0000074C | 32 | rw | 0x00001601 | MIO Pin 19 Control |
| MIO_PIN_20 | 0x00000750 | 32 | rw | 0x00001601 | MIO Pin 20 Control |
| MIO_PIN_21 | 0x00000754 | 32 | rw | 0x00001601 | MIO Pin 21 Control |
| MIO_PIN_22 | 0x00000758 | 32 | rw | 0x00001601 | MIO Pin 22 Control |
| MIO_PIN_23 | 0x0000075C | 32 | rw | 0x00001601 | MIO Pin 23 Control |
| MIO_PIN_24 | 0x00000760 | 32 | rw | 0x00001601 | MIO Pin 24 Control |
| MIO_PIN_25 | 0x00000764 | 32 | rw | 0x00001601 | MIO Pin 25 Control |
| MIO_PIN_26 | 0x00000768 | 32 | rw | 0x00001601 | MIO Pin 26 Control |
| MIO_PIN_27 | 0x0000076C | 32 | rw | 0x00001601 | MIO Pin 27 Control |
| MIO_PIN_28 | 0x00000770 | 32 | rw | 0x00001601 | MIO Pin 28 Control |
| MIO_PIN_29 | 0x00000774 | 32 | rw | 0x00001601 | MIO Pin 29 Control |
| MIO_PIN_30 | 0x00000778 | 32 | rw | 0x00001601 | MIO Pin 30 Control |
| MIO_PIN_31 | 0x0000077C | 32 | rw | 0x00001601 | MIO Pin 31 Control |
| MIO_PIN_32 | 0x00000780 | 32 | rw | 0x00001601 | MIO Pin 32 Control |
| MIO_PIN_33 | 0x00000784 | 32 | rw | 0x00001601 | MIO Pin 33 Control |
| MIO_PIN_34 | 0x00000788 | 32 | rw | 0x00001601 | MIO Pin 34 Control |
| MIO_PIN_35 | 0x0000078C | 32 | rw | 0x00001601 | MIO Pin 35 Control |
| MIO_PIN_36 | 0x00000790 | 32 | rw | 0x00001601 | MIO Pin 36 Control |
| MIO_PIN_37 | 0x00000794 | 32 | rw | 0x00001601 | MIO Pin 37 Control |
| MIO_PIN_38 | 0x00000798 | 32 | rw | 0x00001601 | MIO Pin 38 Control |
| MIO_PIN_39 | 0x0000079C | 32 | rw | 0x00001601 | MIO Pin 39 Control |
| MIO_PIN_40 | 0x000007A0 | 32 | rw | 0x00001601 | MIO Pin 40 Control |
| MIO_PIN_41 | 0x000007A4 | 32 | rw | 0x00001601 | MIO Pin 41 Control |
| MIO_PIN_42 | 0x000007A8 | 32 | rw | 0x00001601 | MIO Pin 42 Control |
| MIO_PIN_43 | 0x000007AC | 32 | rw | 0x00001601 | MIO Pin 43 Control |
| MIO_PIN_44 | 0x000007B0 | 32 | rw | 0x00001601 | MIO Pin 44 Control |
| MIO_PIN_45 | 0x000007B4 | 32 | rw | 0x00001601 | MIO Pin 45 Control |
| MIO_PIN_46 | 0x000007B8 | 32 | rw | 0x00001601 | MIO Pin 46 Control |
| MIO_PIN_47 | 0x000007BC | 32 | rw | 0x00001601 | MIO Pin 47 Control |
| MIO_PIN_48 | 0x000007C0 | 32 | rw | 0x00001601 | MIO Pin 48 Control |
| MIO_PIN_49 | 0x000007C4 | 32 | rw | 0x00001601 | MIO Pin 49 Control |

| Register Name | Address | Width | Type | Reset Value | Description |
|---|------------|-------|-------|--------------|---|
| MIO_PIN_50 | 0x000007C8 | 32 | rw | 0x00001601 | MIO Pin 50 Control |
| MIO_PIN_51 | 0x000007CC | 32 | rw | 0x00001601 | MIO Pin 51 Control |
| MIO_PIN_52 | 0x000007D0 | 32 | rw | 0x00001601 | MIO Pin 52 Control |
| MIO_PIN_53 | 0x000007D4 | 32 | rw | 0x00001601 | MIO Pin 53 Control |
| MIO_LOOPBACK | 0x00000804 | 32 | rw | 0x00000000 | Loopback function within MIO |
| MIO_MST_TRI0 | 0x0000080C | 32 | rw | 0xFFFFFFFF | MIO pin Tri-state Enables, 31:0 |
| MIO_MST_TRI1 | 0x00000810 | 32 | rw | 0x003FFFFFFF | MIO pin Tri-state Enables, 53:32 |
| SD0_WP_CD_SEL | 0x00000830 | 32 | rw | 0x00000000 | SDIO 0 WP CD select |
| SD1_WP_CD_SEL | 0x00000834 | 32 | rw | 0x00000000 | SDIO 1 WP CD select |
| LVL_SHFTR_EN | 0x00000900 | 32 | rw | 0x00000000 | Level Shifters Enable |
| OCM_CFG | 0x00000910 | 32 | rw | 0x00000000 | OCM Address Mapping |
| Reserved | 0x00000A1C | 32 | rw | 0x00010101 | Reserved |
| GPIOB_CTRL | 0x00000B00 | 32 | rw | 0x00000000 | PS IO Buffer Control |
| GPIOB_CFG_CMOS18 | 0x00000B04 | 32 | rw | 0x00000000 | MIO GPIOB CMOS 1.8V config |
| GPIOB_CFG_CMOS25 | 0x00000B08 | 32 | rw | 0x00000000 | MIO GPIOB CMOS 2.5V config |
| GPIOB_CFG_CMOS33 | 0x00000B0C | 32 | rw | 0x00000000 | MIO GPIOB CMOS 3.3V config |
| GPIOB_CFG_HSTL | 0x00000B14 | 32 | rw | 0x00000000 | MIO GPIOB HSTL config |
| GPIOB_DRV_BIAS_CTRL | 0x00000B18 | 32 | mixed | 0x00000000 | MIO GPIOB Driver Bias Control |
| DDRIOB_ADDR0 | 0x00000B40 | 32 | rw | 0x00000800 | DDR IOB Config for A[14:0], CKE and DRST_B |
| DDRIOB_ADDR1 | 0x00000B44 | 32 | rw | 0x00000800 | DDR IOB Config for BA[2:0], ODT, CS_B, WE_B, RAS_B and CAS_B |
| DDRIOB_DATA0 | 0x00000B48 | 32 | rw | 0x00000800 | DDR IOB Config for Data 15:0 |
| DDRIOB_DATA1 | 0x00000B4C | 32 | rw | 0x00000800 | DDR IOB Config for Data 31:16 |
| DDRIOB_DIFF0 | 0x00000B50 | 32 | rw | 0x00000800 | DDR IOB Config for DQS 1:0 |
| DDRIOB_DIFF1 | 0x00000B54 | 32 | rw | 0x00000800 | DDR IOB Config for DQS 3:2 |
| DDRIOB_CLOCK | 0x00000B58 | 32 | rw | 0x00000800 | DDR IOB Config for Clock Output |
| DDRIOB_DRIVE_SLEW_ADDR | 0x00000B5C | 32 | rw | 0x00000000 | Drive and Slew controls for Address and Command pins of the DDR Interface |
| DDRIOB_DRIVE_SLEW_DATA | 0x00000B60 | 32 | rw | 0x00000000 | Drive and Slew controls for DQ pins of the DDR Interface |
| DDRIOB_DRIVE_SLEW_DIFF | 0x00000B64 | 32 | rw | 0x00000000 | Drive and Slew controls for DQS pins of the DDR Interface |
| DDRIOB_DRIVE_SLEW_CLOCK | 0x00000B68 | 32 | rw | 0x00000000 | Drive and Slew controls for Clock pins of the DDR Interface |
| DDRIOB_DDR_CTRL | 0x00000B6C | 32 | rw | 0x00000000 | DDR IOB Buffer Control |

| Register Name | Address | Width | Type | Reset Value | Description |
|-----------------------------------|------------|-------|-------|-------------|--------------------------|
| DDRIOB_DCI_CTRL | 0x00000B70 | 32 | rw | 0x00000020 | DDR IOB DCI Config |
| DDRIOB_DCI_STATUS | 0x00000B74 | 32 | mixed | 0x00000000 | DDR IO Buffer DCI Status |

Register ([slcr](#)) SCL

| | |
|------------------|---------------------------|
| Name | SCL |
| Relative Address | 0x00000000 |
| Absolute Address | 0xF8000000 |
| Width | 32 bits |
| Access Type | rw |
| Reset Value | 0x00000000 |
| Description | Secure Configuration Lock |

Register SCL Details

| Field Name | Bits | Type | Reset Value | Description |
|------------|------|------|-------------|---|
| reserved | 31:1 | rw | 0x0 | Reserved. Writes are ignored, read data is zero. |
| LOCK | 0 | rw | 0x0 | Secure configuration lock for these slcr registers: SCL, PSS_RST_CTRL, APU_CTRL, and WDT_CLK_SEL. Read: 0: unlocked, Secure writes to secure configuration registers are enabled. 1: locked, all writes to secure configuration registers are ignored. Write: 0: noaffect. 1: lock the secure configuration registers. Once the secure registers are locked, they remain locked until a power-on reset cycle (PS_POR_B). |

Register ([slcr](#)) SLCR_LOCK

| | |
|------------------|----------------------------|
| Name | SLCR_LOCK |
| Relative Address | 0x00000004 |
| Absolute Address | 0xF8000004 |
| Width | 32 bits |
| Access Type | wo |
| Reset Value | 0x00000000 |
| Description | SLCR Write Protection Lock |

Register SLCR_LOCK Details

| Field Name | Bits | Type | Reset Value | Description |
|------------|-------|------|-------------|---|
| reserved | 31:16 | wo | 0x0 | Reserved. Writes are ignored, read data is zero. |
| LOCK_KEY | 15:0 | wo | 0x0 | Write the lock key, 0x767B, to write protect the slcr registers: all slcr registers, 0xF800_0000 to 0xF800_0B74, are write protected until the unlock key is written to the SLCR_UNLOCK register. A read of this register returns zero. |

Register ([slcr](#)) SLCR_UNLOCK

| | |
|------------------|------------------------------|
| Name | SLCR_UNLOCK |
| Relative Address | 0x00000008 |
| Absolute Address | 0xF8000008 |
| Width | 32 bits |
| Access Type | wo |
| Reset Value | 0x00000000 |
| Description | SLCR Write Protection Unlock |

Register SLCR_UNLOCK Details

| Field Name | Bits | Type | Reset Value | Description |
|------------|-------|------|-------------|--|
| reserved | 31:16 | wo | 0x0 | Reserved. Writes are ignored, read data is zero. |
| UNLOCK_KEY | 15:0 | wo | 0x0 | Write the unlock key, 0xDF0D, to enable writes to the slcr registers. All slcr registers, 0xF800_0000 to 0xF800_0B74, are writeable until locked using the SLCR_LOCK register. A read of this register returns zero. |

Register ([slcr](#)) SLCR_LOCKSTA

| | |
|------------------|------------------------------|
| Name | SLCR_LOCKSTA |
| Relative Address | 0x0000000C |
| Absolute Address | 0xF800000C |
| Width | 32 bits |
| Access Type | ro |
| Reset Value | 0x00000001 |
| Description | SLCR Write Protection Status |

Register SLCR_LOCKSTA Details

| Field Name | Bits | Type | Reset Value | Description |
|-------------|------|------|-------------|---|
| reserved | 31:1 | ro | 0x0 | Reserved. Writes are ignored, read data is zero. |
| LOCK_STATUS | 0 | ro | 0x1 | Current state of write protection mode of SLCR: 0: Registers are writeable. Use the slcr.SLCR_LOCK register to lock the slcr registers. 1: Registers are not writeable. Any attempt to write to an slcr register is ignored, but reads will return valid register values. Use the slcr.SLCR_UNLOCK register to unlock the slcr registers. |

Register ([slcr](#)) ARM_PLL_CTRL

| | |
|------------------|-----------------|
| Name | ARM_PLL_CTRL |
| Relative Address | 0x00000100 |
| Absolute Address | 0xF8000100 |
| Width | 32 bits |
| Access Type | rw |
| Reset Value | 0x0001A008 |
| Description | Arm PLL Control |

Register ARM_PLL_CTRL Details

| Field Name | Bits | Type | Reset Value | Description |
|------------------|-------|------|-------------|--|
| reserved | 31:19 | rw | 0x0 | Reserved. Writes are ignored, read data is zero. |
| PLL_FDIV | 18:12 | rw | 0x1A | Provide the feedback divisor for the PLL. Note: Before changing this value, the PLL must first be bypassed and then put into reset mode. Refer to the Zynq-7000 TRM, UG585, Clocks chapter for CP/RES/CNT values for the PLL. |
| reserved | 11:5 | rw | 0x0 | Reserved. Writes are ignored, read data is zero. |
| PLL_BYPASS_FORCE | 4 | rw | 0x0 | Arm PLL Bypass override control: PLL_BYPASS_QUAL = 0: 0: enabled, not bypassed. 1: bypassed. PLL_BYPASS_QUAL = 1 (QUAL bit default value): 0: PLL mode is set based on pin strap setting. 1: PLL bypassed regardless of the pin strapping. |

| Field Name | Bits | Type | Reset Value | Description |
|-----------------|------|------|-------------|---|
| PLL_BYPASS_QUAL | 3 | rw | 0x1 | Select the source for the Arm PLL Bypass Control: 0: controlled by the PLL_BYPASS_FORCE bit, bit 4. 1: controlled by the value of the sampled BOOT_MODE pin strapping resistor PLL_BYPASS. This can be read using the BOOT_MODE[4] bit. |
| reserved | 2 | rw | 0x0 | Reserved. Writes are ignored, read data is zero. |
| PLL_PWRDWN | 1 | rw | 0x0 | PLL Power-down control: 0: PLL powered up 1: PLL powered down |
| PLL_RESET | 0 | rw | 0x0 | PLL reset control: 0: de-assert (PLL operating) 1: assert (PLL held in reset) |

Register ([slcr](#)) DDR_PLL_CTRL

| | |
|------------------|-----------------|
| Name | DDR_PLL_CTRL |
| Relative Address | 0x00000104 |
| Absolute Address | 0xF8000104 |
| Width | 32 bits |
| Access Type | rw |
| Reset Value | 0x0001A008 |
| Description | DDR PLL Control |

Register DDR_PLL_CTRL Details

| Field Name | Bits | Type | Reset Value | Description |
|------------------|-------|------|-------------|---|
| reserved | 31:19 | rw | 0x0 | Reserved. Writes are ignored, read data is zero. |
| PLL_FDIV | 18:12 | rw | 0x1A | Provide the feedback divisor for the PLL. Note: Before changing this value, the PLL must first be bypassed and then put into reset mode. Refer to the Zynq-7000 TRM, UG585, Clocks chapter for CP/RES/CNT values for the PLL. |
| reserved | 11:5 | rw | 0x0 | Reserved. Writes are ignored, read data is zero. |
| PLL_BYPASS_FORCE | 4 | rw | 0x0 | DDR PLL Bypass override control: PLL_BYPASS_QUAL = 0 0: enabled, not bypassed. 1: bypassed. PLL_BYPASS_QUAL = 1 (QUAL bit default value) 0: PLL mode is set based on pin strap setting. 1: PLL bypass is enabled regardless of the pin strapping. |

| Field Name | Bits | Type | Reset Value | Description |
|-----------------|------|------|-------------|---|
| PLL_BYPASS_QUAL | 3 | rw | 0x1 | Select the source for the DDR PLL Bypass: 0: controlled by the PLL_BYPASS_FORCE bit. 1: controlled by the value of the sampled BOOT_MODE pin strapping resistor PLL_BYPASS. This can be read using the slcr.BOOT_MODE[4] bit. |
| reserved | 2 | rw | 0x0 | Reserved. Writes are ignored, read data is zero. |
| PLL_PWRDWN | 1 | rw | 0x0 | PLL Power-down control: 0: PLL powered up 1: PLL powered down |
| PLL_RESET | 0 | rw | 0x0 | PLL reset control: 0: de-assert (PLL operating) 1: assert (PLL held in reset) |

Register ([slcr](#)) IO_PLL_CTRL

| | |
|------------------|----------------|
| Name | IO_PLL_CTRL |
| Relative Address | 0x00000108 |
| Absolute Address | 0xF8000108 |
| Width | 32 bits |
| Access Type | rw |
| Reset Value | 0x0001A008 |
| Description | IO PLL Control |

Register IO_PLL_CTRL Details

| Field Name | Bits | Type | Reset Value | Description |
|------------------|-------|------|-------------|--|
| reserved | 31:19 | rw | 0x0 | Reserved. Writes are ignored, read data is zero. |
| PLL_FDIV | 18:12 | rw | 0x1A | Provide the feedback divisor for the PLL. Note: Before changing this value, the PLL must first be bypassed and then put into reset mode. Refer to the Zynq-7000 TRM, UG585, Clocks chapter for CP/RES/CNT values for programming the PLL. |
| reserved | 11:5 | rw | 0x0 | Reserved. Writes are ignored, read data is zero. |
| PLL_BYPASS_FORCE | 4 | rw | 0x0 | IO PLL Bypass override control: PLL_BYPASS_QUAL = 0 0: enabled, not bypassed. 1: bypassed. PLL_BYPASS_QUAL = 1 (QUAL bit default value) 0: PLL mode is set based on pin strap setting. 1: PLL bypass is enabled regardless of the pin strapping. |

| Field Name | Bits | Type | Reset Value | Description |
|-----------------|------|------|-------------|--|
| PLL_BYPASS_QUAL | 3 | rw | 0x1 | Select the source for the IO PLL Bypass: 0: controlled by the PLL_BYPASS_FORCE bit. 1: controlled by the value of the sampled BOOT_MODE pin strapping resistor PLL_BYPASS. This can be read using the slcr.BOOT_MODE[4] bit. |
| reserved | 2 | rw | 0x0 | Reserved. Writes are ignored, read data is zero. |
| PLL_PWRDWN | 1 | rw | 0x0 | PLL Power-down control: 0: PLL powered up 1: PLL powered down |
| PLL_RESET | 0 | rw | 0x0 | PLL Reset control: 0: de-assert (PLL operating) 1: assert (PLL held in reset) |

Register ([slcr](#)) PLL_STATUS

| | |
|------------------|------------|
| Name | PLL_STATUS |
| Relative Address | 0x0000010C |
| Absolute Address | 0xF800010C |
| Width | 32 bits |
| Access Type | ro |
| Reset Value | 0x0000003F |
| Description | PLL Status |

Register PLL_STATUS Details

Note: Reset condition is actually 0, but will read a 1 by the time this register can be read by software if PLLs are enabled by BOOT_MODE.

| Field Name | Bits | Type | Reset Value | Description |
|----------------|------|------|-------------|--|
| reserved | 31:6 | ro | 0x0 | Reserved. Writes are ignored, read data is zero. |
| IO_PLL_STABLE | 5 | ro | 0x1 | IO PLL clock stable status: 0: not locked and not in bypass 1: locked or bypassed |
| DDR_PLL_STABLE | 4 | ro | 0x1 | DDR PLL clock stable status: 0: not locked and not in bypass 1: locked or bypassed |
| ARM_PLL_STABLE | 3 | ro | 0x1 | Arm PLL clock stable status: 0: not locked and not in bypass 1: locked or bypassed |
| IO_PLL_LOCK | 2 | ro | 0x1 | IO PLL lock status: 0: not locked, 1: locked |

| Field Name | Bits | Type | Reset Value | Description |
|--------------|------|------|-------------|--|
| DDR_PLL_LOCK | 1 | ro | 0x1 | DDR PLL lock status: 0: not locked, 1: locked |
| ARM_PLL_LOCK | 0 | ro | 0x1 | Arm PLL lock status: 0: not locked, 1: locked |

Register ([slcr](#)) ARM_PLL_CFG

| | |
|------------------|-----------------------|
| Name | ARM_PLL_CFG |
| Relative Address | 0x00000110 |
| Absolute Address | 0xF8000110 |
| Width | 32 bits |
| Access Type | rw |
| Reset Value | 0x00177EA0 |
| Description | Arm PLL Configuration |

Register ARM_PLL_CFG Details

| Field Name | Bits | Type | Reset Value | Description |
|------------|-------|------|-------------|---|
| reserved | 31:22 | rw | 0x0 | Reserved. Writes are ignored, read data is zero. |
| LOCK_CNT | 21:12 | rw | 0x177 | Drive the LOCK_CNT[9:0] input of the PLL to set the number of clock cycles the PLL needs to have clkref and clkfb aligned with a certain window before syaing locked. |
| PLL_CP | 11:8 | rw | 0xE | Drive the PLL_CP[3:0] input of the PLL to set the PLL charge pump control |
| PLL_RES | 7:4 | rw | 0xA | Drive the PLL_RES[3:0] input of the PLL to set the PLL loop filter resistor control |
| reserved | 3:0 | rw | 0x0 | Reserved. Writes are ignored, read data is zero. |

Register ([slcr](#)) DDR_PLL_CFG

| | |
|------------------|-----------------------|
| Name | DDR_PLL_CFG |
| Relative Address | 0x00000114 |
| Absolute Address | 0xF8000114 |
| Width | 32 bits |
| Access Type | rw |
| Reset Value | 0x00177EA0 |
| Description | DDR PLL Configuration |

Register DDR_PLL_CFG Details

| Field Name | Bits | Type | Reset Value | Description |
|------------|-------|------|-------------|--|
| reserved | 31:22 | rw | 0x0 | Reserved. Writes are ignored, read data is zero. |
| LOCK_CNT | 21:12 | rw | 0x177 | Drive the LOCK_CNT[9:0] input of the PLL to set the number of clock cycles the PLL needs to have clkref and clkfb aligned with a certain window before staying locked. |
| PLL_CP | 11:8 | rw | 0xE | Drive the PLL_CP[3:0] input of the PLL to set the PLL charge pump control. |
| PLL_RES | 7:4 | rw | 0xA | Drive the PLL_RES[3:0] input of the PLL to set the PLL loop filter resistor control. |
| reserved | 3:0 | rw | 0x0 | Reserved. Writes are ignored, read data is zero. |

Register ([slcr](#)) IO_PLL_CFG

| | |
|------------------|----------------------|
| Name | IO_PLL_CFG |
| Relative Address | 0x00000118 |
| Absolute Address | 0xF8000118 |
| Width | 32 bits |
| Access Type | rw |
| Reset Value | 0x00177EA0 |
| Description | IO PLL Configuration |

Register IO_PLL_CFG Details

| Field Name | Bits | Type | Reset Value | Description |
|------------|-------|------|-------------|--|
| reserved | 31:22 | rw | 0x0 | Reserved. Writes are ignored, read data is zero. |
| LOCK_CNT | 21:12 | rw | 0x177 | Drive the LOCK_CNT[9:0] input of the PLL to set the number of clock cycles the PLL needs to have clkref and clkfb aligned with a certain window before staying locked. |
| PLL_CP | 11:8 | rw | 0xE | Drive the PLL_CP[3:0] input of the PLL to set the PLL charge pump control. |
| PLL_RES | 7:4 | rw | 0xA | Drive the PLL_RES[3:0] input of the PLL to set the PLL loop filter resistor control. |
| reserved | 3:0 | rw | 0x0 | Reserved. Writes are ignored, read data is zero. |

Register ([slcr](#)) ARM_CLK_CTRL

| | |
|------------------|--------------|
| Name | ARM_CLK_CTRL |
| Relative Address | 0x00000120 |

Absolute Address 0xF8000120
 Width 32 bits
 Access Type rw
 Reset Value 0x1F000400
 Description CPU Clock Control

Register ARM_CLK_CTRL Details

| Field Name | Bits | Type | Reset Value | Description |
|-----------------|-------|------|-------------|---|
| reserved | 31:29 | rw | 0x0 | Reserved. Writes are ignored, read data is zero. |
| CPU_PERI_CLKACT | 28 | rw | 0x1 | Clock active: 0: Clock is disabled 1: Clock is enabled |
| CPU_1XCLKACT | 27 | rw | 0x1 | CPU_1x Clock control: 0: disable, 1: enable |
| CPU_2XCLKACT | 26 | rw | 0x1 | CPU_2x Clock control: 0: disable, 1: enable |
| CPU_3OR2XCLKACT | 25 | rw | 0x1 | CPU_3x2x Clock control: 0: disable, 1: enable |
| CPU_6OR4XCLKACT | 24 | rw | 0x1 | CPU_6x4x Clock control: 0: disable, 1: enable |
| reserved | 23:14 | rw | 0x0 | Reserved. Writes are ignored, read data is zero. |
| DIVISOR | 13:8 | rw | 0x4 | Frequency divisor for the CPU clock source. 0, 1: do not use. 2: divide by 2. 3: divide by 3. ... 3Fh: divide by 63. |
| reserved | 7:6 | rw | 0x0 | Reserved. Writes are ignored, read data is zero. |
| SRCSEL | 5:4 | rw | 0x0 | Select the source used to generate the CPU clock: 0x: Arm PLL 10: DDR PLL 11: IO PLL This field is reset by POR only. |
| reserved | 3:0 | rw | 0x0 | Reserved. Writes are ignored, read data is zero. |

Register ([slcr](#)) DDR_CLK_CTRL

Name DDR_CLK_CTRL
 Relative Address 0x00000124
 Absolute Address 0xF8000124
 Width 32 bits

Access Type rw
 Reset Value 0x18400003
 Description DDR Clock Control

Register DDR_CLK_CTRL Details

Note: the DDR_3x and DDR_2x clocks are asynchronous to each other and without a fixed frequency ratio. The frequency of each DDR clock is independently programmed. Generally, the DDR_3x clock runs faster than the DDR2x clock.

| Field Name | Bits | Type | Reset Value | Description |
|-------------------|-------|------|-------------|--|
| DDR_2XCLK_DIVISOR | 31:26 | rw | 0x6 | Frequency divisor for the ddr_2x clock |
| DDR_3XCLK_DIVISOR | 25:20 | rw | 0x4 | Frequency divisor for the ddr_3x clock. (Only even divisors are allowed) |
| reserved | 19:2 | rw | 0x0 | Reserved. Writes are ignored, read data is zero. |
| DDR_2XCLKACT | 1 | rw | 0x1 | DDR_2x Clock control: 0: disable, 1: enable |
| DDR_3XCLKACT | 0 | rw | 0x1 | DDR_3x Clock control: 0: disable, 1: enable |

Register ([slcr](#)) DCI_CLK_CTRL

Name DCI_CLK_CTRL
 Relative Address 0x00000128
 Absolute Address 0xF8000128
 Width 32 bits
 Access Type rw
 Reset Value 0x01E03201
 Description DCI clock control

Register DCI_CLK_CTRL Details

| Field Name | Bits | Type | Reset Value | Description |
|------------|-------|------|-------------|---|
| reserved | 31:26 | rw | 0x0 | Reserved. Writes are ignored, read data is zero. |
| DIVISOR1 | 25:20 | rw | 0x1E | Provides the divisor used to divide the source clock to generate the required generated clock frequency. Second cascade divider |
| reserved | 19:14 | rw | 0x0 | Reserved. Writes are ignored, read data is zero. |
| DIVISOR0 | 13:8 | rw | 0x32 | Provides the divisor used to divide the source clock to generate the required generated clock frequency. |

| Field Name | Bits | Type | Reset Value | Description |
|------------|------|------|-------------|--|
| reserved | 7:1 | rw | 0x0 | Reserved. Writes are ignored, read data is zero. |
| CLKACT | 0 | rw | 0x1 | DCI clock control 0: Disable 1: Enable |

Register ([slcr](#)) APER_CLK_CTRL

| | |
|------------------|-------------------------------|
| Name | APER_CLK_CTRL |
| Relative Address | 0x0000012C |
| Absolute Address | 0xF800012C |
| Width | 32 bits |
| Access Type | rw |
| Reset Value | 0x01FFCCCD |
| Description | AMBA Peripheral Clock Control |

Register APER_CLK_CTRL Details

Please note that these clocks must be enabled if you want to read from the peripheral register space.

| Field Name | Bits | Type | Reset Value | Description |
|--------------------|-------|------|-------------|--|
| reserved | 31:25 | rw | 0x0 | Reserved. Writes are ignored, read data is zero. |
| SMC_CPU_1XCLKACT | 24 | rw | 0x1 | SMC AMBA Clock control 0: disable, 1: enable |
| LQSPI_CPU_1XCLKACT | 23 | rw | 0x1 | Quad SPI AMBA Clock control 0: disable, 1: enable |
| GPIO_CPU_1XCLKACT | 22 | rw | 0x1 | GPIO AMBA Clock control 0: disable, 1: enable |
| UART1_CPU_1XCLKACT | 21 | rw | 0x1 | UART 1 AMBA Clock control 0: disable, 1: enable |
| UART0_CPU_1XCLKACT | 20 | rw | 0x1 | UART 0 AMBA Clock control 0: disable, 1: enable |
| I2C1_CPU_1XCLKACT | 19 | rw | 0x1 | I2C 1 AMBA Clock control 0: disable, 1: enable |
| I2C0_CPU_1XCLKACT | 18 | rw | 0x1 | I2C 0 AMBA Clock control 0: disable, 1: enable |
| CAN1_CPU_1XCLKACT | 17 | rw | 0x1 | CAN 1 AMBA Clock control 0: disable, 1: enable |
| CAN0_CPU_1XCLKACT | 16 | rw | 0x1 | CAN 0 AMBA Clock control 0: disable, 1: enable |
| SPI1_CPU_1XCLKACT | 15 | rw | 0x1 | SPI 1 AMBA Clock control 0: disable, 1: enable |

| Field Name | Bits | Type | Reset Value | Description |
|-------------------|------|------|-------------|--|
| SPI0_CPU_1XCLKACT | 14 | rw | 0x1 | SPI 0 AMBA Clock control 0: disable, 1: enable |
| reserved | 13 | rw | 0x0 | Reserved. Writes are ignored, read data is zero. |
| reserved | 12 | rw | 0x0 | Reserved. Writes are ignored, read data is zero. |
| SDI1_CPU_1XCLKACT | 11 | rw | 0x1 | SDIO controller 1 AMBA Clock control 0: disable, 1: enable |
| SDI0_CPU_1XCLKACT | 10 | rw | 0x1 | SDIO controller 0 AMBA Clock 0: disable, 1: enable |
| reserved | 9 | rw | 0x0 | Reserved. Writes are ignored, read data is zero. |
| reserved | 8 | rw | 0x0 | Reserved. Writes are ignored, read data is zero. |
| GEM1_CPU_1XCLKACT | 7 | rw | 0x1 | Gigabit Ethernet 1 AMBA Clock control 0: disable, 1: enable |
| GEM0_CPU_1XCLKACT | 6 | rw | 0x1 | Gigabit Ethernet 0 AMBA Clock control 0: disable, 1: enable |
| reserved | 5 | rw | 0x0 | Reserved. Writes are ignored, read data is zero. |
| reserved | 4 | rw | 0x0 | Reserved. Writes are ignored, read data is zero. |
| USB1_CPU_1XCLKACT | 3 | rw | 0x1 | USB controller 1 AMBA Clock control 0: disable, 1: enable |
| USB0_CPU_1XCLKACT | 2 | rw | 0x1 | USB controller 0 AMBA Clock control 0: disable, 1: enable |
| reserved | 1 | rw | 0x0 | Reserved. Writes are ignored, read data is zero. |
| DMA_CPU_2XCLKACT | 0 | rw | 0x1 | DMA controller AMBA Clock control 0: disable, 1: enable |

Register ([slcr](#)) USB0_CLK_CTRL

| | |
|------------------|--------------------------|
| Name | USB0_CLK_CTRL |
| Relative Address | 0x00000130 |
| Absolute Address | 0xF8000130 |
| Width | 32 bits |
| Access Type | rw |
| Reset Value | 0x00101941 |
| Description | USB 0 ULPI Clock Control |

Register USB0_CLK_CTRL Details

| Field Name | Bits | Type | Reset Value | Description |
|------------|-------|------|-------------|--|
| reserved | 31:26 | rw | 0x0 | Reserved. Writes are ignored, read data is zero. |
| reserved | 25:20 | rw | 0x1 | Reserved. Do not modify. |
| reserved | 19:14 | rw | 0x0 | Reserved. Writes are ignored, read data is zero. |
| reserved | 13:8 | rw | 0x19 | Reserved. Do not modify. |
| reserved | 7 | rw | 0x0 | Reserved. Writes are ignored, read data is zero. |
| SRCSEL | 6:4 | rw | 0x4 | Select the source to generate USB controller 0 ULPI clock: 1xx: USB 0 MIO ULPI clock (top level MIO ULPI clock is an input) |
| reserved | 3:1 | rw | 0x0 | Reserved. Writes are ignored, read data is zero. |
| reserved | 0 | rw | 0x1 | Reserved. Do not modify. |

Register ([slcr](#)) USB1_CLK_CTRL

| | |
|------------------|--------------------------|
| Name | USB1_CLK_CTRL |
| Relative Address | 0x00000134 |
| Absolute Address | 0xF8000134 |
| Width | 32 bits |
| Access Type | rw |
| Reset Value | 0x00101941 |
| Description | USB 1 ULPI Clock Control |

Register USB1_CLK_CTRL Details

| Field Name | Bits | Type | Reset Value | Description |
|------------|-------|------|-------------|--|
| reserved | 31:26 | rw | 0x0 | Reserved. Writes are ignored, read data is zero. |
| reserved | 25:20 | rw | 0x1 | Reserved. Do not modify. |
| reserved | 19:14 | rw | 0x0 | Reserved. Writes are ignored, read data is zero. |
| reserved | 13:8 | rw | 0x19 | Reserved. Do not modify. |
| reserved | 7 | rw | 0x0 | Reserved. Writes are ignored, read data is zero. |
| SRCSEL | 6:4 | rw | 0x4 | Select the source to generate USB controller 1 ULPI clock: 1xx: USB 1 MIO ULPI clock (top level MIO ULPI clock is an input) |
| reserved | 3:1 | rw | 0x0 | Reserved. Writes are ignored, read data is zero. |
| reserved | 0 | rw | 0x1 | Reserved. Do not modify. |

Register ([slcr](#)) GEM0_RCLK_CTRL

Name GEM0_RCLK_CTRL
 Relative Address 0x00000138
 Absolute Address 0xF8000138
 Width 32 bits
 Access Type rw
 Reset Value 0x00000001
 Description GigE 0 Rx Clock and Rx Signals Select

Register GEM0_RCLK_CTRL Details

| Field Name | Bits | Type | Reset Value | Description |
|------------|------|------|-------------|---|
| reserved | 31:5 | rw | 0x0 | Reserved. Writes are ignored, read data is zero. |
| SRCSEL | 4 | rw | 0x0 | Select the source of the Rx clock, control and data signals: 0: MIO 1: EMIO |
| reserved | 3:1 | rw | 0x0 | Reserved. Writes are ignored, read data is zero. |
| CLKACT | 0 | rw | 0x1 | Ethernet Controller 0 Rx Clock control 0: disable, 1: enable |

Register ([slcr](#)) GEM1_RCLK_CTRL

Name GEM1_RCLK_CTRL
 Relative Address 0x0000013C
 Absolute Address 0xF800013C
 Width 32 bits
 Access Type rw
 Reset Value 0x00000001
 Description GigE 1 Rx Clock and Rx Signals Select

Register GEM1_RCLK_CTRL Details

| Field Name | Bits | Type | Reset Value | Description |
|------------|------|------|-------------|---|
| reserved | 31:5 | rw | 0x0 | Reserved. Writes are ignored, read data is zero. |
| SRCSEL | 4 | rw | 0x0 | Select the source of the Rx clock, control and data signals: 0: MIO 1: EMIO |

| Field Name | Bits | Type | Reset Value | Description |
|------------|------|------|-------------|---|
| reserved | 3:1 | rw | 0x0 | Reserved. Writes are ignored, read data is zero. |
| CLKACT | 0 | rw | 0x1 | Ethernet Controller 1 Rx Clock control 0: disable, 1: enable |

Register ([slcr](#)) GEM0_CLK_CTRL

| | |
|------------------|--------------------------|
| Name | GEM0_CLK_CTRL |
| Relative Address | 0x00000140 |
| Absolute Address | 0xF8000140 |
| Width | 32 bits |
| Access Type | rw |
| Reset Value | 0x00003C01 |
| Description | GigE 0 Ref Clock Control |

Register GEM0_CLK_CTRL Details

| Field Name | Bits | Type | Reset Value | Description |
|------------|-------|------|-------------|--|
| reserved | 31:26 | rw | 0x0 | Reserved. Writes are ignored, read data is zero. |
| DIVISOR1 | 25:20 | rw | 0x0 | Second divisor for Ethernet controller 0 source clock. |
| reserved | 19:14 | rw | 0x0 | Reserved. Writes are ignored, read data is zero. |
| DIVISOR | 13:8 | rw | 0x3C | First divisor for Ethernet controller 0 source clock. |
| reserved | 7 | rw | 0x0 | Reserved. Writes are ignored, read data is zero. |
| SRCSEL | 6:4 | rw | 0x0 | Selects the source to generate the reference clock 00x: IO PLL. 010: Arm PLL. 011: DDR PLL 1xx: Ethernet controller 0 EMIO clock |
| reserved | 3:1 | rw | 0x0 | Reserved. Writes are ignored, read data is zero. |
| CLKACT | 0 | rw | 0x1 | Ethernet Controller 0 Reference Clock control 0: disable, 1: enable |

Register ([slcr](#)) GEM1_CLK_CTRL

| | |
|------------------|---------------|
| Name | GEM1_CLK_CTRL |
| Relative Address | 0x00000144 |
| Absolute Address | 0xF8000144 |
| Width | 32 bits |
| Access Type | rw |

Reset Value 0x00003C01
 Description GigE 1 Ref Clock Control

Register GEM1_CLK_CTRL Details

| Field Name | Bits | Type | Reset Value | Description |
|------------|-------|------|-------------|--|
| reserved | 31:26 | rw | 0x0 | Reserved. Writes are ignored, read data is zero. |
| DIVISOR1 | 25:20 | rw | 0x0 | Second divisor for Ethernet controller 1 source clock. |
| reserved | 19:14 | rw | 0x0 | Reserved. Writes are ignored, read data is zero. |
| DIVISOR | 13:8 | rw | 0x3C | First divisor for Ethernet controller 1 source clock. |
| reserved | 7 | rw | 0x0 | Reserved. Writes are ignored, read data is zero. |
| SRCSEL | 6:4 | rw | 0x0 | Selects the source to generate the reference clock 00x: IO PLL. 010: Arm PLL. 011: DDR PLL 1xx: Ethernet controller 1 EMIO clock |
| reserved | 3:1 | rw | 0x0 | Reserved. Writes are ignored, read data is zero. |
| CLKACT | 0 | rw | 0x1 | Ethernet Controller 1 Reference Clock control 0: disable, 1: enable |

Register ([slcr](#)) SMC_CLK_CTRL

Name SMC_CLK_CTRL
 Relative Address 0x00000148
 Absolute Address 0xF8000148
 Width 32 bits
 Access Type rw
 Reset Value 0x00003C21
 Description SMC Ref Clock Control

Register SMC_CLK_CTRL Details

| Field Name | Bits | Type | Reset Value | Description |
|------------|-------|------|-------------|---|
| reserved | 31:14 | rw | 0x0 | Reserved. Writes are ignored, read data is zero. |
| DIVISOR | 13:8 | rw | 0x3C | Divisor for SMC source clock. |
| reserved | 7:6 | rw | 0x0 | Reserved. Writes are ignored, read data is zero. |
| SRCSEL | 5:4 | rw | 0x2 | Select clock source generate SMC clock: 0x: IO PLL, 10: Arm PLL, 11: DDR PLL |

| Field Name | Bits | Type | Reset Value | Description |
|------------|------|------|-------------|--|
| reserved | 3:1 | rw | 0x0 | Reserved. Writes are ignored, read data is zero. |
| CLKACT | 0 | rw | 0x1 | SMC Reference Clock control 0: disable, 1: enable |

Register ([slcr](#)) LQSPI_CLK_CTRL

| | |
|------------------|----------------------------|
| Name | LQSPI_CLK_CTRL |
| Relative Address | 0x0000014C |
| Absolute Address | 0xF800014C |
| Width | 32 bits |
| Access Type | rw |
| Reset Value | 0x00002821 |
| Description | Quad SPI Ref Clock Control |

Register LQSPI_CLK_CTRL Details

| Field Name | Bits | Type | Reset Value | Description |
|------------|-------|------|-------------|--|
| reserved | 31:14 | rw | 0x0 | Reserved. Writes are ignored, read data is zero. |
| DIVISOR | 13:8 | rw | 0x28 | Divisor for Quad SPI Controller source clock. |
| reserved | 7:6 | rw | 0x0 | Reserved. Writes are ignored, read data is zero. |
| SRCSEL | 5:4 | rw | 0x2 | Select clock source generate Quad SPI clock: 0x: IO PLL, 10: Arm PLL, 11: DDR PLL |
| reserved | 3:1 | rw | 0x0 | Reserved. Writes are ignored, read data is zero. |
| CLKACT | 0 | rw | 0x1 | Quad SPI Controller Reference Clock control 0: disable, 1: enable |

Register ([slcr](#)) SDIO_CLK_CTRL

| | |
|------------------|------------------------|
| Name | SDIO_CLK_CTRL |
| Relative Address | 0x00000150 |
| Absolute Address | 0xF8000150 |
| Width | 32 bits |
| Access Type | rw |
| Reset Value | 0x00001E03 |
| Description | SDIO Ref Clock Control |

Register SDIO_CLK_CTRL Details

| Field Name | Bits | Type | Reset Value | Description |
|------------|-------|------|-------------|--|
| reserved | 31:14 | rw | 0x0 | Reserved. Writes are ignored, read data is zero. |
| DIVISOR | 13:8 | rw | 0x1E | Provides the divisor used to divide the source clock to generate the required generated clock frequency. |
| reserved | 7:6 | rw | 0x0 | Reserved. Writes are ignored, read data is zero. |
| SRCSEL | 5:4 | rw | 0x0 | Select the source used to generate the clock. 0x: Source for generated clock is IO PLL. 10: Source for generated clock is Arm PLL. 11: Source for generated clock is DDR PLL. |
| reserved | 3:2 | rw | 0x0 | Reserved. Writes are ignored, read data is zero. |
| CLKACT1 | 1 | rw | 0x1 | SDIO Controller 1 Clock control. 0: disable, 1: enable |
| CLKACT0 | 0 | rw | 0x1 | SDIO Controller 0 Clock control. 0: disable, 1: enable |

Register ([slcr](#)) UART_CLK_CTRL

| | |
|------------------|------------------------|
| Name | UART_CLK_CTRL |
| Relative Address | 0x00000154 |
| Absolute Address | 0xF8000154 |
| Width | 32 bits |
| Access Type | rw |
| Reset Value | 0x00003F03 |
| Description | UART Ref Clock Control |

Register UART_CLK_CTRL Details

| Field Name | Bits | Type | Reset Value | Description |
|------------|-------|------|-------------|---|
| reserved | 31:14 | rw | 0x0 | Reserved. Writes are ignored, read data is zero. |
| DIVISOR | 13:8 | rw | 0x3F | Divisor for UART Controller source clock. |
| reserved | 7:6 | rw | 0x0 | Reserved. Writes are ignored, read data is zero. |
| SRCSEL | 5:4 | rw | 0x0 | Selects the PLL source to generate the clock. 0x: IO PLL 10: Arm PLL 11: DDR PLL |
| reserved | 3:2 | rw | 0x0 | Reserved. Writes are ignored, read data is zero. |

| Field Name | Bits | Type | Reset Value | Description |
|------------|------|------|-------------|---|
| CLKACT1 | 1 | rw | 0x1 | UART 1 reference clock active: 0: Clock is disabled 1: Clock is enabled |
| CLKACT0 | 0 | rw | 0x1 | UART 0 Reference clock control. 0: disable, 1: enable |

Register ([slcr](#)) SPI_CLK_CTRL

| | |
|------------------|-----------------------|
| Name | SPI_CLK_CTRL |
| Relative Address | 0x00000158 |
| Absolute Address | 0xF8000158 |
| Width | 32 bits |
| Access Type | rw |
| Reset Value | 0x00003F03 |
| Description | SPI Ref Clock Control |

Register SPI_CLK_CTRL Details

| Field Name | Bits | Type | Reset Value | Description |
|------------|-------|------|-------------|--|
| reserved | 31:14 | rw | 0x0 | Reserved. Writes are ignored, read data is zero. |
| DIVISOR | 13:8 | rw | 0x3F | Provides the divisor used to divide the source clock to generate the required generated clock frequency. |
| reserved | 7:6 | rw | 0x0 | Reserved. Writes are ignored, read data is zero. |
| SRCSEL | 5:4 | rw | 0x0 | Select the source used to generate the clock: 0x: Source for generated clock is IO PLL. 10: Source for generated clock is Arm PLL. 11: Source for generated clock is DDR PLL. |
| reserved | 3:2 | rw | 0x0 | Reserved. Writes are ignored, read data is zero. |
| CLKACT1 | 1 | rw | 0x1 | SPI 1 reference clock active: 0: Clock is disabled 1: Clock is enabled |
| CLKACT0 | 0 | rw | 0x1 | SPI 0 reference clock active: 0: Clock is disabled 1: Clock is enabled |

Register ([slcr](#)) CAN_CLK_CTRL

| | |
|------------------|--------------|
| Name | CAN_CLK_CTRL |
| Relative Address | 0x0000015C |

Absolute Address 0xF800015C
 Width 32 bits
 Access Type rw
 Reset Value 0x00501903
 Description CAN Ref Clock Control

Register CAN_CLK_CTRL Details

| Field Name | Bits | Type | Reset Value | Description |
|------------|-------|------|-------------|--|
| reserved | 31:26 | rw | 0x0 | Reserved. Writes are ignored, read data is zero. |
| DIVISOR1 | 25:20 | rw | 0x5 | Provides the divisor used to divide the source clock to generate the required generated clock frequency. Second cascade divider. |
| reserved | 19:14 | rw | 0x0 | Reserved. Writes are ignored, read data is zero. |
| DIVISOR0 | 13:8 | rw | 0x19 | Provides the divisor used to divide the source clock to generate the required generated clock frequency. First cascade divider |
| reserved | 7:6 | rw | 0x0 | Reserved. Writes are ignored, read data is zero. |
| SRCSEL | 5:4 | rw | 0x0 | Select the source used to generate the clock: 0x: Source for generated clock is IO PLL. 10: Source for generated clock is Arm PLL. 11: Source for generated clock is DDR PLL. |
| reserved | 3:2 | rw | 0x0 | Reserved. Writes are ignored, read data is zero. |
| CLKACT1 | 1 | rw | 0x1 | CAN 1 Reference Clock active: 0: Clock is disabled 1: Clock is enabled |
| CLKACT0 | 0 | rw | 0x1 | CAN 0 Reference Clock active: 0: Clock is disabled 1: Clock is enabled |

Register ([slcr](#)) CAN_MIOCLK_CTRL

Name CAN_MIOCLK_CTRL
 Relative Address 0x00000160
 Absolute Address 0xF8000160
 Width 32 bits
 Access Type rw
 Reset Value 0x00000000
 Description CAN MIO Clock Control

Register CAN_MIOCLK_CTRL Details

| Field Name | Bits | Type | Reset Value | Description |
|--------------|-------|------|-------------|---|
| reserved | 31:23 | rw | 0x0 | Reserved. Writes are ignored, read data is zero. |
| CAN1_REF_SEL | 22 | rw | 0x0 | CAN 1 Reference Clock selection: 0: From internal PLL. 1: From MIO based on the next field |
| CAN1_MUX | 21:16 | rw | 0x0 | CAN 1 mux selection for MIO. Setting this to zero will select MIO[0] as the clock source. Only values 0-53 are valid. |
| reserved | 15:7 | rw | 0x0 | Reserved. Writes are ignored, read data is zero. |
| CAN0_REF_SEL | 6 | rw | 0x0 | CAN 0 Reference Clock selection: 0: From internal PLL 1: From MIO based on the next field |
| CAN0_MUX | 5:0 | rw | 0x0 | CAN 0 mux selection for MIO. Setting this to zero will select MIO[0] as the clock source. Only values 0-53 are valid. |

Register ([slcr](#)) DBG_CLK_CTRL

| | |
|------------------|-------------------------|
| Name | DBG_CLK_CTRL |
| Relative Address | 0x00000164 |
| Absolute Address | 0xF8000164 |
| Width | 32 bits |
| Access Type | rw |
| Reset Value | 0x00000F03 |
| Description | SoC Debug Clock Control |

Register DBG_CLK_CTRL Details

| Field Name | Bits | Type | Reset Value | Description |
|------------|-------|------|-------------|--|
| reserved | 31:14 | rw | 0x0 | Reserved. Writes are ignored, read data is zero. |
| DIVISOR | 13:8 | rw | 0xF | Provides the divisor used to divide the source clock to generate the required generated debug trace clock frequency. |
| reserved | 7 | rw | 0x0 | Reserved. Writes are ignored, read data is zero. |
| SRCSEL | 6:4 | rw | 0x0 | Select the source used to generate the clock: 1xx: Source for generated clock EMIO trace clock 00x: Source for generated clock is IO PLL 010: Source for generated clock is Arm PLL 011: Source for generated clock is DDR PLL |

| Field Name | Bits | Type | Reset Value | Description |
|--------------|------|------|-------------|---|
| reserved | 3:2 | rw | 0x0 | Reserved. Writes are ignored, read data is zero. |
| CPU_1XCLKACT | 1 | rw | 0x1 | Debug CPU 1x Clock active. 0 - Clocks are disabled. 1 - Clocks are enabled |
| CLKACT_TRC | 0 | rw | 0x1 | Debug Trace Clock active: 0: Clock is disabled 1: Clock is enabled |

Register ([slcr](#)) PCAP_CLK_CTRL

| | |
|------------------|--------------------|
| Name | PCAP_CLK_CTRL |
| Relative Address | 0x00000168 |
| Absolute Address | 0xF8000168 |
| Width | 32 bits |
| Access Type | rw |
| Reset Value | 0x00000F01 |
| Description | PCAP Clock Control |

Register PCAP_CLK_CTRL Details

| Field Name | Bits | Type | Reset Value | Description |
|------------|-------|------|-------------|--|
| reserved | 31:14 | rw | 0x0 | Reserved. Writes are ignored, read data is zero. |
| DIVISOR | 13:8 | rw | 0xF | Provides the divisor used to divide the source clock to generate the required generated clock frequency. |
| reserved | 7:6 | rw | 0x0 | Reserved. Writes are ignored, read data is zero. |
| SRCSEL | 5:4 | rw | 0x0 | Select the source used to generate the clock: 0x: Source for generated clock is IO PLL. 10: Source for generated clock is Arm PLL. 11: Source for generated clock is DDR PLL. |
| reserved | 3:1 | rw | 0x0 | Reserved. Writes are ignored, read data is zero. |
| CLKACT | 0 | rw | 0x1 | Clock active: 0: Clock is disabled 1: Clock is enabled |

Register ([slcr](#)) TOPSW_CLK_CTRL

| | |
|------------------|----------------|
| Name | TOPSW_CLK_CTRL |
| Relative Address | 0x0000016C |
| Absolute Address | 0xF800016C |

Width 32 bits
 Access Type rw
 Reset Value 0x00000000
 Description Central Interconnect Clock Control

Register TOPSW_CLK_CTRL Details

| Field Name | Bits | Type | Reset Value | Description |
|------------|------|------|-------------|--|
| reserved | 31:1 | rw | 0x0 | Reserved. Writes are ignored, read data is zero. |
| CLK_DIS | 0 | rw | 0x0 | Clock disable control: 0: Clock is not disabled 1: Clock can be disabled |

Register ([slcr](#)) FPGA0_CLK_CTRL

Name FPGA0_CLK_CTRL
 Relative Address 0x00000170
 Absolute Address 0xF8000170
 Width 32 bits
 Access Type rw
 Reset Value 0x00101800
 Description PL Clock 0 Output control

Register FPGA0_CLK_CTRL Details

| Field Name | Bits | Type | Reset Value | Description |
|------------|-------|------|-------------|--|
| reserved | 31:26 | rw | 0x0 | Reserved. Writes are ignored, read data is zero. |
| DIVISOR1 | 25:20 | rw | 0x1 | Provides the divisor used to divide the source clock to generate the required generated clock frequency. Second cascade divide |
| reserved | 19:14 | rw | 0x0 | Reserved. Writes are ignored, read data is zero. |
| DIVISOR0 | 13:8 | rw | 0x18 | Provides the divisor used to divide the source clock to generate the required generated clock frequency. First cascade divider. |
| reserved | 7:6 | rw | 0x0 | Reserved. Writes are ignored, read data is zero. |
| SRCSEL | 5:4 | rw | 0x0 | Select the source used to generate the clock: 0x: Source for generated clock is IO PLL. 10: Source for generated clock is Arm PLL. 11: Source for generated clock is DDR PLL. |
| reserved | 3:0 | rw | 0x0 | Reserved. Writes are ignored, read data is zero. |

Register ([slcr](#)) FPGA0_THR_CTRL

| | |
|------------------|-----------------------------|
| Name | FPGA0_THR_CTRL |
| Relative Address | 0x00000174 |
| Absolute Address | 0xF8000174 |
| Width | 32 bits |
| Access Type | rw |
| Reset Value | 0x00000000 |
| Description | PL Clock 0 Throttle control |

Register FPGA0_THR_CTRL Details

| Field Name | Bits | Type | Reset Value | Description |
|------------|------|------|-------------|---|
| reserved | 31:4 | rw | 0x0 | Reserved. Writes are ignored, read data is zero. |
| reserved | 3 | rw | 0x0 | Must be set to 1'b0 to use this feature |
| reserved | 2 | rw | 0x0 | Must be set to 1'b1 to use this feature |
| CNT_RST | 1 | rw | 0x0 | Reset clock throttle counter when in halt state: 0: No effect 1: Causes counter to be reset once HALT state is entered |
| CPU_START | 0 | rw | 0x0 | Start or restart count on detection of 0 to 1 transition in the value of this bit. A read will return the written value. (Reminder that bits 2&3 must be programmed according to description.) 0: No effect 1: Start count or restart count if previous value was 0 |

Register ([slcr](#)) FPGA0_THR_CNT

| | |
|------------------|-----------------------------------|
| Name | FPGA0_THR_CNT |
| Relative Address | 0x00000178 |
| Absolute Address | 0xF8000178 |
| Width | 32 bits |
| Access Type | rw |
| Reset Value | 0x00000000 |
| Description | PL Clock 0 Throttle Count control |

Register FPGA0_THR_CNT Details

| Field Name | Bits | Type | Reset Value | Description |
|------------|-------|------|-------------|--|
| reserved | 31:20 | rw | 0x0 | Reserved. Writes are ignored, read data is zero. |
| reserved | 19:16 | rw | 0x0 | Reserved. Do not modify. |
| LAST_CNT | 15:0 | rw | 0x0 | Last count value. Specifies the total number of clocks output in debug mode by the clock throttle logic. |

Register ([slcr](#)) FPGA0_THR_STA

| | |
|------------------|---------------------------------|
| Name | FPGA0_THR_STA |
| Relative Address | 0x0000017C |
| Absolute Address | 0xF800017C |
| Width | 32 bits |
| Access Type | ro |
| Reset Value | 0x00010000 |
| Description | PL Clock 0 Throttle Status read |

Register FPGA0_THR_STA Details

| Field Name | Bits | Type | Reset Value | Description |
|------------|-------|------|-------------|---|
| reserved | 31:17 | ro | 0x0 | Reserved. Writes are ignored, read data is zero. |
| RUNNING | 16 | ro | 0x1 | Current running status of FPGA clock output: 0: Clock is stopped or in normal mode (OK to change configuration). 1: Clock is running in debug mode (Keep configuration static). |
| CURR_VAL | 15:0 | ro | 0x0 | Current clock throttle counter value, which indicates the number of clock pulses output so far (only accurate when halted). |

Register ([slcr](#)) FPGA1_CLK_CTRL

| | |
|------------------|---------------------------|
| Name | FPGA1_CLK_CTRL |
| Relative Address | 0x00000180 |
| Absolute Address | 0xF8000180 |
| Width | 32 bits |
| Access Type | rw |
| Reset Value | 0x00101800 |
| Description | PL Clock 1 Output control |

Register FPGA1_CLK_CTRL Details

| Field Name | Bits | Type | Reset Value | Description |
|------------|-------|------|-------------|--|
| reserved | 31:26 | rw | 0x0 | Reserved. Writes are ignored, read data is zero. |
| DIVISOR1 | 25:20 | rw | 0x1 | Provides the divisor used to divide the source clock to generate the required generated clock frequency. Second cascade divide |
| reserved | 19:14 | rw | 0x0 | Reserved. Writes are ignored, read data is zero. |
| DIVISOR0 | 13:8 | rw | 0x18 | Provides the divisor used to divide the source clock to generate the required generated clock frequency. First cascade divider. |
| reserved | 7:6 | rw | 0x0 | Reserved. Writes are ignored, read data is zero. |
| SRCSEL | 5:4 | rw | 0x0 | Select the source used to generate the clock: 0x: Source for generated clock is IO PLL. 10: Source for generated clock is Arm PLL. 11: Source for generated clock is DDR PLL. |
| reserved | 3:0 | rw | 0x0 | Reserved. Writes are ignored, read data is zero. |

Register ([slcr](#)) FPGA1_THR_CTRL

| | |
|------------------|-----------------------------|
| Name | FPGA1_THR_CTRL |
| Relative Address | 0x00000184 |
| Absolute Address | 0xF8000184 |
| Width | 32 bits |
| Access Type | rw |
| Reset Value | 0x00000000 |
| Description | PL Clock 1 Throttle control |

Register FPGA1_THR_CTRL Details

| Field Name | Bits | Type | Reset Value | Description |
|------------|------|------|-------------|--|
| reserved | 31:4 | rw | 0x0 | Reserved. Writes are ignored, read data is zero. |
| reserved | 3 | rw | 0x0 | Must be set to 1'b0 to use this feature |
| reserved | 2 | rw | 0x0 | Must be set to 1'b1 to use this feature |

| Field Name | Bits | Type | Reset Value | Description |
|------------|------|------|-------------|---|
| CNT_RST | 1 | rw | 0x0 | Reset clock throttle counter when in halt state: 0: No effect 1: Causes counter to be reset once HALT state is entered |
| CPU_START | 0 | rw | 0x0 | Start or restart count on detection of 0 to 1 transition in the value of this bit. A read will return the written value. (Reminder that bits 2&3 must be programmed according to description.) 0: No effect 1: Start count or restart count if previous value was 0 |

Register ([slcr](#)) FPGA1_THR_CNT

| | |
|------------------|---------------------------|
| Name | FPGA1_THR_CNT |
| Relative Address | 0x00000188 |
| Absolute Address | 0xF8000188 |
| Width | 32 bits |
| Access Type | rw |
| Reset Value | 0x00000000 |
| Description | PL Clock 1 Throttle Count |

Register FPGA1_THR_CNT Details

| Field Name | Bits | Type | Reset Value | Description |
|------------|-------|------|-------------|--|
| reserved | 31:20 | rw | 0x0 | Reserved. Writes are ignored, read data is zero. |
| reserved | 19:16 | rw | 0x0 | Reserved. Do not modify. |
| LAST_CNT | 15:0 | rw | 0x0 | Last count value. Specifies the total number of clocks output in debug mode by the clock throttle logic. |

Register ([slcr](#)) FPGA1_THR_STA

| | |
|------------------|------------------------------------|
| Name | FPGA1_THR_STA |
| Relative Address | 0x0000018C |
| Absolute Address | 0xF800018C |
| Width | 32 bits |
| Access Type | ro |
| Reset Value | 0x00010000 |
| Description | PL Clock 1 Throttle Status control |

Register FPGA1_THR_STA Details

| Field Name | Bits | Type | Reset Value | Description |
|------------|-------|------|-------------|---|
| reserved | 31:17 | ro | 0x0 | Reserved. Writes are ignored, read data is zero. |
| RUNNING | 16 | ro | 0x1 | Current running status of FPGA clock output: 0: Clock is stopped or in normal mode (OK to change configuration). 1: Clock is running in debug mode (Keep configuration static). |
| CURR_VAL | 15:0 | ro | 0x0 | Current clock throttle counter value, which indicates the number of clock pulses output so far (only accurate when halted). |

Register ([slcr](#)) FPGA2_CLK_CTRL

| | |
|------------------|---------------------------|
| Name | FPGA2_CLK_CTRL |
| Relative Address | 0x00000190 |
| Absolute Address | 0xF8000190 |
| Width | 32 bits |
| Access Type | rw |
| Reset Value | 0x00101800 |
| Description | PL Clock 2 output control |

Register FPGA2_CLK_CTRL Details

| Field Name | Bits | Type | Reset Value | Description |
|------------|-------|------|-------------|--|
| reserved | 31:26 | rw | 0x0 | Reserved. Writes are ignored, read data is zero. |
| DIVISOR1 | 25:20 | rw | 0x1 | Provides the divisor used to divide the source clock to generate the required generated clock frequency. Second cascade divide |
| reserved | 19:14 | rw | 0x0 | Reserved. Writes are ignored, read data is zero. |
| DIVISOR0 | 13:8 | rw | 0x18 | Provides the divisor used to divide the source clock to generate the required generated clock frequency. First cascade divider. |
| reserved | 7:6 | rw | 0x0 | Reserved. Writes are ignored, read data is zero. |
| SRCSEL | 5:4 | rw | 0x0 | Select the source used to generate the clock: 0x: Source for generated clock is IO PLL. 10: Source for generated clock is Arm PLL. 11: Source for generated clock is DDR PLL. |
| reserved | 3:0 | rw | 0x0 | Reserved. Writes are ignored, read data is zero. |

Register ([slcr](#)) FPGA2_THR_CTRL

| | |
|------------------|-----------------------------|
| Name | FPGA2_THR_CTRL |
| Relative Address | 0x00000194 |
| Absolute Address | 0xF8000194 |
| Width | 32 bits |
| Access Type | rw |
| Reset Value | 0x00000000 |
| Description | PL Clock 2 Throttle Control |

Register FPGA2_THR_CTRL Details

| Field Name | Bits | Type | Reset Value | Description |
|------------|------|------|-------------|---|
| reserved | 31:4 | rw | 0x0 | Reserved. Writes are ignored, read data is zero. |
| reserved | 3 | rw | 0x0 | Must be set to 1'b0 to use this feature |
| reserved | 2 | rw | 0x0 | Must be set to 1'b1 to use this feature |
| CNT_RST | 1 | rw | 0x0 | Reset clock throttle counter when in halt state: 0: No effect 1: Causes counter to be reset once HALT state is entered |
| CPU_START | 0 | rw | 0x0 | Start or restart count on detection of 0 to 1 transition in the value of this bit. A read will return the written value. (Reminder that bits 2&3 must be programmed according to description.) 0: No effect 1: Start count or restart count if previous value was 0 |

Register ([slcr](#)) FPGA2_THR_CNT

| | |
|------------------|---------------------------|
| Name | FPGA2_THR_CNT |
| Relative Address | 0x00000198 |
| Absolute Address | 0xF8000198 |
| Width | 32 bits |
| Access Type | rw |
| Reset Value | 0x00000000 |
| Description | PL Clock 2 Throttle Count |

Register FPGA2_THR_CNT Details

| Field Name | Bits | Type | Reset Value | Description |
|------------|-------|------|-------------|--|
| reserved | 31:20 | rw | 0x0 | Reserved. Writes are ignored, read data is zero. |
| reserved | 19:16 | rw | 0x0 | Reserved. Do not modify. |
| LAST_CNT | 15:0 | rw | 0x0 | Last count value. Specifies the total number of clocks output in debug mode by the clock throttle logic. |

Register ([slcr](#)) FPGA2_THR_STA

| | |
|------------------|----------------------------|
| Name | FPGA2_THR_STA |
| Relative Address | 0x0000019C |
| Absolute Address | 0xF800019C |
| Width | 32 bits |
| Access Type | ro |
| Reset Value | 0x00010000 |
| Description | PL Clock 2 Throttle Status |

Register FPGA2_THR_STA Details

| Field Name | Bits | Type | Reset Value | Description |
|------------|-------|------|-------------|---|
| reserved | 31:17 | ro | 0x0 | Reserved. Writes are ignored, read data is zero. |
| RUNNING | 16 | ro | 0x1 | Current running status of FPGA clock output: 0: Clock is stopped or in normal mode (OK to change configuration). 1: Clock is running in debug mode (Keep configuration static). |
| CURR_VAL | 15:0 | ro | 0x0 | Current clock throttle counter value, which indicates the number of clock pulses output so far (only accurate when halted). |

Register ([slcr](#)) FPGA3_CLK_CTRL

| | |
|------------------|---------------------------|
| Name | FPGA3_CLK_CTRL |
| Relative Address | 0x000001A0 |
| Absolute Address | 0xF80001A0 |
| Width | 32 bits |
| Access Type | rw |
| Reset Value | 0x00101800 |
| Description | PL Clock 3 output control |

Register FPGA3_CLK_CTRL Details

| Field Name | Bits | Type | Reset Value | Description |
|------------|-------|------|-------------|--|
| reserved | 31:26 | rw | 0x0 | Reserved. Writes are ignored, read data is zero. |
| DIVISOR1 | 25:20 | rw | 0x1 | Provides the divisor used to divide the source clock to generate the required generated clock frequency. Second cascade divide |
| reserved | 19:14 | rw | 0x0 | Reserved. Writes are ignored, read data is zero. |
| DIVISOR0 | 13:8 | rw | 0x18 | Provides the divisor used to divide the source clock to generate the required generated clock frequency. First cascade divider. |
| reserved | 7:6 | rw | 0x0 | Reserved. Writes are ignored, read data is zero. |
| SRCSEL | 5:4 | rw | 0x0 | Select the source used to generate the clock: 0x: Source for generated clock is IO PLL. 10: Source for generated clock is Arm PLL. 11: Source for generated clock is DDR PLL. |
| reserved | 3:0 | rw | 0x0 | Reserved. Writes are ignored, read data is zero. |

Register ([slcr](#)) FPGA3_THR_CTRL

| | |
|------------------|-----------------------------|
| Name | FPGA3_THR_CTRL |
| Relative Address | 0x000001A4 |
| Absolute Address | 0xF80001A4 |
| Width | 32 bits |
| Access Type | rw |
| Reset Value | 0x00000000 |
| Description | PL Clock 3 Throttle Control |

Register FPGA3_THR_CTRL Details

| Field Name | Bits | Type | Reset Value | Description |
|------------|------|------|-------------|--|
| reserved | 31:4 | rw | 0x0 | Reserved. Writes are ignored, read data is zero. |
| reserved | 3 | rw | 0x0 | Must be set to 1'b0 to use this feature |
| reserved | 2 | rw | 0x0 | Must be set to 1'b1 to use this feature |

| Field Name | Bits | Type | Reset Value | Description |
|------------|------|------|-------------|---|
| CNT_RST | 1 | rw | 0x0 | Reset clock throttle counter when in halt state: 0: No effect 1: Causes counter to be reset once HALT state is entered |
| CPU_START | 0 | rw | 0x0 | Start or restart count on detection of 0 to 1 transition in the value of this bit. A read will return the written value. (Reminder that bits 2&3 must be programmed according to description.) 0: No effect 1: Start count or restart count if previous value was 0 |

Register ([slcr](#)) FPGA3_THR_CNT

| | |
|------------------|---------------------------|
| Name | FPGA3_THR_CNT |
| Relative Address | 0x000001A8 |
| Absolute Address | 0xF80001A8 |
| Width | 32 bits |
| Access Type | rw |
| Reset Value | 0x00000000 |
| Description | PL Clock 3 Throttle Count |

Register FPGA3_THR_CNT Details

| Field Name | Bits | Type | Reset Value | Description |
|------------|-------|------|-------------|--|
| reserved | 31:20 | rw | 0x0 | Reserved. Writes are ignored, read data is zero. |
| reserved | 19:16 | rw | 0x0 | Reserved. Do not modify. |
| LAST_CNT | 15:0 | rw | 0x0 | Last count value. Specifies the total number of clocks output in debug mode by the clock throttle logic. |

Register ([slcr](#)) FPGA3_THR_STA

| | |
|------------------|----------------------------|
| Name | FPGA3_THR_STA |
| Relative Address | 0x000001AC |
| Absolute Address | 0xF80001AC |
| Width | 32 bits |
| Access Type | ro |
| Reset Value | 0x00010000 |
| Description | PL Clock 3 Throttle Status |

Register FPGA3_THR_STA Details

| Field Name | Bits | Type | Reset Value | Description |
|------------|-------|------|-------------|---|
| reserved | 31:17 | ro | 0x0 | Reserved. Writes are ignored, read data is zero. |
| RUNNING | 16 | ro | 0x1 | Current running status of FPGA clock output: 0: Clock is stopped or in normal mode (OK to change configuration). 1: Clock is running in debug mode (Keep configuration static). |
| CURR_VAL | 15:0 | ro | 0x0 | Current clock throttle counter value, which indicates the number of clock pulses output so far (only accurate when halted). |

Register ([slcr](#)) CLK_621_TRUE

| | |
|------------------|-----------------------------|
| Name | CLK_621_TRUE |
| Relative Address | 0x000001C4 |
| Absolute Address | 0xF80001C4 |
| Width | 32 bits |
| Access Type | rw |
| Reset Value | 0x00000001 |
| Description | CPU Clock Ratio Mode select |

Register CLK_621_TRUE Details

| Field Name | Bits | Type | Reset Value | Description |
|--------------|------|------|-------------|--|
| reserved | 31:1 | rw | 0x0 | Reserved. Writes are ignored, read data is zero. |
| CLK_621_TRUE | 0 | rw | 0x1 | Select the CPU clock ratio: (When this register changes, no access are allowed to OCM.) 0: 4:2:1 1: 6:2:1 |

Register ([slcr](#)) PSS_RST_CTRL

| | |
|------------------|--------------|
| Name | PSS_RST_CTRL |
| Relative Address | 0x00000200 |
| Absolute Address | 0xF8000200 |
| Width | 32 bits |
| Access Type | rw |
| Reset Value | 0x00000000 |

Description PS Software Reset Control

Register PSS_RST_CTRL Details

| Field Name | Bits | Type | Reset Value | Description |
|------------|------|------|-------------|--|
| reserved | 31:1 | rw | 0x0 | Reserved. Writes are ignored, read data is zero. |
| SOFT_RST | 0 | rw | 0x0 | Processing System software reset control signal. 0: no affect 1: asserts PS software reset pulse (entire system except clock generator) There is no need to write a 0, the hardware generates a pulse everytime a 1 is written. |

Register ([slcr](#)) DDR_RST_CTRL

Name DDR_RST_CTRL
 Relative Address 0x00000204
 Absolute Address 0xF8000204
 Width 32 bits
 Access Type rw
 Reset Value 0x00000000
 Description DDR Software Reset Control

Register DDR_RST_CTRL Details

| Field Name | Bits | Type | Reset Value | Description |
|------------|------|------|-------------|--|
| reserved | 31:1 | rw | 0x0 | Reserved. Writes are ignored, read data is zero. |
| DDR_RST | 0 | rw | 0x0 | DDR software reset control signal 0: disable, 1: enable |

Register ([slcr](#)) TOPSW_RST_CTRL

Name TOPSW_RST_CTRL
 Relative Address 0x00000208
 Absolute Address 0xF8000208
 Width 32 bits
 Access Type rw
 Reset Value 0x00000000
 Description Central Interconnect Reset Control

Register TOPSW_RST_CTRL Details

| Field Name | Bits | Type | Reset Value | Description |
|------------|------|------|-------------|---|
| reserved | 31:1 | rw | 0x0 | Reserved. Writes are ignored, read data is zero. |
| TOPSW_RST | 0 | rw | 0x0 | Central Interconnect Reset Control: 0: de-assert (no reset) 1: assert Care must be taken to ensure that the AXI interconnect does not have outstanding transactions and the bus is idle. |

Register ([slcr](#)) DMAC_RST_CTRL

| | |
|------------------|-----------------------------|
| Name | DMAC_RST_CTRL |
| Relative Address | 0x0000020C |
| Absolute Address | 0xF800020C |
| Width | 32 bits |
| Access Type | rw |
| Reset Value | 0x00000000 |
| Description | DMAC Software Reset Control |

Register DMAC_RST_CTRL Details

| Field Name | Bits | Type | Reset Value | Description |
|------------|------|------|-------------|--|
| reserved | 31:1 | rw | 0x0 | Reserved. Writes are ignored, read data is zero. |
| DMAC_RST | 0 | rw | 0x0 | DMA Controller software reset signal. 0: de-assert (DMA controller TrustZone register is read only) 1: assert (DMA controller TrustZone register is writeable) |

Register ([slcr](#)) USB_RST_CTRL

| | |
|------------------|----------------------------|
| Name | USB_RST_CTRL |
| Relative Address | 0x00000210 |
| Absolute Address | 0xF8000210 |
| Width | 32 bits |
| Access Type | rw |
| Reset Value | 0x00000000 |
| Description | USB Software Reset Control |

Register USB_RST_CTRL Details

| Field Name | Bits | Type | Reset Value | Description |
|----------------|------|------|-------------|--|
| reserved | 31:2 | rw | 0x0 | Reserved. Writes are ignored, read data is zero. |
| USB1_CPU1X_RST | 1 | rw | 0x0 | USB 1 master and slave AMBA interfaces software reset: 0: de-assert (no reset) 1: assert (held in reset) |
| USB0_CPU1X_RST | 0 | rw | 0x0 | USB 0 master and slave AMBA interfaces software reset: 0: de-assert (no reset) 1: assert (held in reset) |

Register ([slcr](#)) GEM_RST_CTRL

| | |
|------------------|-----------------------------------|
| Name | GEM_RST_CTRL |
| Relative Address | 0x00000214 |
| Absolute Address | 0xF8000214 |
| Width | 32 bits |
| Access Type | rw |
| Reset Value | 0x00000000 |
| Description | Gigabit Ethernet SW Reset Control |

Register GEM_RST_CTRL Details

Each Gigabit Ethernet controller has 3 clock domains and each clock domain has a reset control:

- * Reference clock domain reset
- * RxClock domain reset
- * CPU_1x clock domain reset

| Field Name | Bits | Type | Reset Value | Description |
|--------------|------|------|-------------|--|
| reserved | 31:8 | rw | 0x0 | Reserved. Writes are ignored, read data is zero. |
| GEM1_REF_RST | 7 | rw | 0x0 | Gigabit Ethernet 1 reference clock reset: 0: de-assert (no reset) 1: assert (interfaces are held in reset) |
| GEM0_REF_RST | 6 | rw | 0x0 | Gigabit Ethernet 0 reference clock domain reset: 0: de-assert (no reset) 1: assert (controller is held in reset) |
| GEM1_RX_RST | 5 | rw | 0x0 | Gigabit Ethernet 1 Rx clock domain reset: 0: de-assert (no reset) 1: assert (held in reset) |

| Field Name | Bits | Type | Reset Value | Description |
|----------------|------|------|-------------|---|
| GEM0_RX_RST | 4 | rw | 0x0 | Gigabit Ethernet 0 Rx clock domain reset: 0: de-assert (no reset) 1: assert (held in reset) |
| reserved | 3:2 | rw | 0x0 | Reserved. Writes are ignored, read data is zero. |
| GEM1_CPU1X_RST | 1 | rw | 0x0 | Gigabit Ethernet 1 CPU_1x clock domain reset: 0: de-assert (no reset) 1: assert (held in reset) |
| GEM0_CPU1X_RST | 0 | rw | 0x0 | Gigabit Ethernet 0 CPU_1x clock domain reset: 0: de-assert (no reset) 1: assert (held in reset) |

Register ([slcr](#)) SDIO_RST_CTRL

| | |
|------------------|-----------------------------|
| Name | SDIO_RST_CTRL |
| Relative Address | 0x00000218 |
| Absolute Address | 0xF8000218 |
| Width | 32 bits |
| Access Type | rw |
| Reset Value | 0x00000000 |
| Description | SDIO Software Reset Control |

Register SDIO_RST_CTRL Details

| Field Name | Bits | Type | Reset Value | Description |
|-----------------|------|------|-------------|--|
| reserved | 31:6 | rw | 0x0 | Reserved. Writes are ignored, read data is zero. |
| SDIO1_REF_RST | 5 | rw | 0x0 | SDIO 1 reference clock domain reset: 0: de-assert (no reset) 1: assert (controller is held in reset) |
| SDIO0_REF_RST | 4 | rw | 0x0 | SDIO 0 reference clock domain reset: 0: de-assert (no reset) 1: assert (controller is held in reset) |
| reserved | 3:2 | rw | 0x0 | Reserved. Writes are ignored, read data is zero. |
| SDIO1_CPU1X_RST | 1 | rw | 0x0 | SDIO 1 master and slave AMBA interfaces reset: 0: de-assert (no reset) 1: assert (held in reset) |
| SDIO0_CPU1X_RST | 0 | rw | 0x0 | SDIO 0 master and slave AMBA interfaces reset: 0: de-assert (no reset) 1: assert (held in reset) |

Register ([slcr](#)) SPI_RST_CTRL

| | |
|------------------|----------------------------|
| Name | SPI_RST_CTRL |
| Relative Address | 0x0000021C |
| Absolute Address | 0xF800021C |
| Width | 32 bits |
| Access Type | rw |
| Reset Value | 0x00000000 |
| Description | SPI Software Reset Control |

Register SPI_RST_CTRL Details

| Field Name | Bits | Type | Reset Value | Description |
|----------------|------|------|-------------|---|
| reserved | 31:4 | rw | 0x0 | Reserved. Writes are ignored, read data is zero. |
| SPI1_REF_RST | 3 | rw | 0x0 | SPI 1 Reference software reset. On assertion of this reset, the Reference clock portion of the SPI 1 subsystem will be reset. 0: No reset 1: Reference clock portion of SPI 1 subsystem held in reset |
| SPI0_REF_RST | 2 | rw | 0x0 | SPI 0 Reference software reset. On assertion of this reset, the Reference clock portion of the SPI 0 subsystem will be reset. 0: No reset 1: Reference clock portion of SPI 0 subsystem held in reset |
| SPI1_CPU1X_RST | 1 | rw | 0x0 | SPI 1 AMBA software reset. On assertion of this reset, the AMBA clock portion of the SPI 1 subsystem will be reset. 0: No reset 1: AMBA clock portion of SPI 1 subsystem held in reset |
| SPI0_CPU1X_RST | 0 | rw | 0x0 | SPI 0 AMBA software reset. On assertion of this reset, the AMBA clock portion of the SPI 0 subsystem will be reset. 0: No reset 1: AMBA clock portion of SPI 0 subsystem held in reset |

Register ([slcr](#)) CAN_RST_CTRL

| | |
|------------------|--------------|
| Name | CAN_RST_CTRL |
| Relative Address | 0x00000220 |
| Absolute Address | 0xF8000220 |

Width 32 bits
 Access Type rw
 Reset Value 0x00000000
 Description CAN Software Reset Control

Register CAN_RST_CTRL Details

| Field Name | Bits | Type | Reset Value | Description |
|----------------|------|------|-------------|--|
| reserved | 31:4 | rw | 0x0 | Reserved. Writes are ignored, read data is zero. |
| reserved | 3 | rw | 0x0 | Reserved. Writes will maintain value |
| reserved | 2 | rw | 0x0 | Reserved. Writes will maintain value |
| CAN1_CPU1X_RST | 1 | rw | 0x0 | CAN 1 AMBA software reset. On assertion of this reset, the AMBA clock portion of the CAN 1 subsystem will be reset. 0: No reset 1: AMBA clock portion of CAN 1 subsystem held in reset |
| CAN0_CPU1X_RST | 0 | rw | 0x0 | CAN 0 AMBA software reset. On assertion of this reset, the AMBA clock portion of the CAN 0 subsystem will be reset. 0: No reset 1: AMBA clock portion of CAN 0 subsystem held in reset |

Register ([slcr](#)) I2C_RST_CTRL

Name I2C_RST_CTRL
 Relative Address 0x00000224
 Absolute Address 0xF8000224
 Width 32 bits
 Access Type rw
 Reset Value 0x00000000
 Description I2C Software Reset Control

Register I2C_RST_CTRL Details

| Field Name | Bits | Type | Reset Value | Description |
|----------------|------|------|-------------|--|
| reserved | 31:2 | rw | 0x0 | Reserved. Writes are ignored, read data is zero. |
| I2C1_CPU1X_RST | 1 | rw | 0x0 | I2C 1 AMBA software reset. On assertion of this reset, the AMBA clock portion of the I2C 1 subsystem will be reset. 0: No reset 1: AMBA clock portion of I2C 1 subsystem held in reset |
| I2C0_CPU1X_RST | 0 | rw | 0x0 | I2C 0 AMBA software reset. On assertion of this reset, the AMBA clock portion of the I2C 0 subsystem will be reset. 0: No reset 1: AMBA clock portion of I2C 0 subsystem held in reset |

Register ([slcr](#)) UART_RST_CTRL

| | |
|------------------|-----------------------------|
| Name | UART_RST_CTRL |
| Relative Address | 0x00000228 |
| Absolute Address | 0xF8000228 |
| Width | 32 bits |
| Access Type | rw |
| Reset Value | 0x00000000 |
| Description | UART Software Reset Control |

Register UART_RST_CTRL Details

| Field Name | Bits | Type | Reset Value | Description |
|---------------|------|------|-------------|--|
| reserved | 31:4 | rw | 0x0 | Reserved. Writes are ignored, read data is zero. |
| UART1_REF_RST | 3 | rw | 0x0 | UART 1 Reference software reset. 0: deassert soft reset 1: assert soft reset |
| UART0_REF_RST | 2 | rw | 0x0 | UART 0 Reference software reset. 0: deassert soft reset 1: assert soft reset |

| Field Name | Bits | Type | Reset Value | Description |
|-----------------|------|------|-------------|---|
| UART1_CPU1X_RST | 1 | rw | 0x0 | UART 1 AMBA software reset. On assertion of this reset, the AMBA clock portion of the UART 1 subsystem will be reset. 0: No reset 1: AMBA clock portion of UART 1 subsystem held in reset |
| UART0_CPU1X_RST | 0 | rw | 0x0 | UART 0 AMBA software reset. On assertion of this reset, the AMBA clock portion of the UART 0 subsystem will be reset. 0: No reset 1: AMBA clock portion of UART 0 subsystem held in reset |

Register ([slcr](#)) GPIO_RST_CTRL

| | |
|------------------|-----------------------------|
| Name | GPIO_RST_CTRL |
| Relative Address | 0x0000022C |
| Absolute Address | 0xF800022C |
| Width | 32 bits |
| Access Type | rw |
| Reset Value | 0x00000000 |
| Description | GPIO Software Reset Control |

Register GPIO_RST_CTRL Details

| Field Name | Bits | Type | Reset Value | Description |
|----------------|------|------|-------------|---|
| reserved | 31:1 | rw | 0x0 | Reserved. Writes are ignored, read data is zero. |
| GPIO_CPU1X_RST | 0 | rw | 0x0 | GPIO AMBA software reset. On assertion of this reset, the AMBA clock portion of the GPIO subsystem will be reset. 0: No reset 1: AMBA clock portion of GPIO subsystem held in reset |

Register ([slcr](#)) LQSPI_RST_CTRL

| | |
|------------------|----------------|
| Name | LQSPI_RST_CTRL |
| Relative Address | 0x00000230 |
| Absolute Address | 0xF8000230 |
| Width | 32 bits |
| Access Type | rw |
| Reset Value | 0x00000000 |

Description Quad SPI Software Reset Control

Register LQSPI_RST_CTRL Details

| Field Name | Bits | Type | Reset Value | Description |
|-----------------|------|------|-------------|--|
| reserved | 31:2 | rw | 0x0 | Reserved. Writes are ignored, read data is zero. |
| QSPI_REF_RST | 1 | rw | 0x0 | Quad SPI Reference software reset. On assertion of this reset, the Reference clock portion of the QSPI subsystem will be reset. 0: No reset. 1: Reference clock portion of QSPI subsystem held in reset. |
| LQSPI_CPU1X_RST | 0 | rw | 0x0 | Quad SPI AMBA software reset. On assertion of this reset, the AMBA clock portion of the LQSPI subsystem will be reset. 0: No reset 1: AMBA clock portion of QSPI subsystem held in reset |

Register ([slcr](#)) SMC_RST_CTRL

Name SMC_RST_CTRL
 Relative Address 0x00000234
 Absolute Address 0xF8000234
 Width 32 bits
 Access Type rw
 Reset Value 0x00000000
 Description SMC Software Reset Control

Register SMC_RST_CTRL Details

| Field Name | Bits | Type | Reset Value | Description |
|---------------|------|------|-------------|---|
| reserved | 31:2 | rw | 0x0 | Reserved. Writes are ignored, read data is zero. |
| SMC_REF_RST | 1 | rw | 0x0 | SMC Reference software reset. On assertion of this reset, the Reference clock portion of the SMC subsystem will be reset. 0: No reset 1: Reference clock portion of SMC subsystem held in reset |
| SMC_CPU1X_RST | 0 | rw | 0x0 | SMC AMBA software reset. On assertion of this reset, the AMBA clock portion of the SMC subsystem will be reset. 0: No reset 1: AMBA clock portion of SMC subsystem held in reset |

Register ([slcr](#)) OCM_RST_CTRL

| | |
|------------------|----------------------------|
| Name | OCM_RST_CTRL |
| Relative Address | 0x00000238 |
| Absolute Address | 0xF8000238 |
| Width | 32 bits |
| Access Type | rw |
| Reset Value | 0x00000000 |
| Description | OCM Software Reset Control |

Register OCM_RST_CTRL Details

| Field Name | Bits | Type | Reset Value | Description |
|------------|------|------|-------------|---|
| reserved | 31:1 | rw | 0x0 | Reserved. Writes are ignored, read data is zero. |
| OCM_RST | 0 | rw | 0x0 | OCM software reset. On assertion of this reset, the OCM subsystem will be reset. 0: No reset 1: OCM subsystem held in reset |

Register ([slcr](#)) FPGA_RST_CTRL

| | |
|------------------|-----------------------------|
| Name | FPGA_RST_CTRL |
| Relative Address | 0x00000240 |
| Absolute Address | 0xF8000240 |
| Width | 32 bits |
| Access Type | rw |
| Reset Value | 0x01F33F0F |
| Description | FPGA Software Reset Control |

Register FPGA_RST_CTRL Details

| Field Name | Bits | Type | Reset Value | Description |
|------------|-------|------|-------------|--|
| reserved | 31:25 | rw | 0x0 | Reserved. Writes are ignored, read data is zero. |
| reserved | 24 | rw | 0x1 | Reserved - always write with 0 |
| reserved | 23 | rw | 0x1 | Reserved - always write with 0 |
| reserved | 22 | rw | 0x1 | Reserved - always write with 0 |
| reserved | 21 | rw | 0x1 | Reserved - always write with 0 |
| reserved | 20 | rw | 0x1 | Reserved - always write with 0 |
| reserved | 19:18 | rw | 0x0 | Reserved. Writes are ignored, read data is zero. |

| Field Name | Bits | Type | Reset Value | Description |
|---------------|-------|------|-------------|--|
| reserved | 17 | rw | 0x1 | Reserved - always write with 0 |
| reserved | 16 | rw | 0x1 | Reserved - always write with 0 |
| reserved | 15:14 | rw | 0x0 | Reserved. Writes are ignored, read data is zero. |
| reserved | 13 | rw | 0x1 | Reserved - always write with 0 |
| reserved | 12 | rw | 0x1 | Reserved - always write with 0 |
| reserved | 11 | rw | 0x1 | Reserved - always write with 0 |
| reserved | 10 | rw | 0x1 | Reserved - always write with 0 |
| reserved | 9 | rw | 0x1 | Reserved - always write with 0 |
| reserved | 8 | rw | 0x1 | Reserved - always write with 0 |
| reserved | 7:4 | rw | 0x0 | Reserved. Writes are ignored, read data is zero. |
| FPGA3_OUT_RST | 3 | rw | 0x1 | PL Reset 3 (FCLKRESETN3 output signal). Refer to the PS7 wrapper in EDK for possible signal inversion. Logic level on the FCLKRESETN3 signal: 0: De-assert reset (High logic level). 1: Assert Reset (Low logic state) |
| FPGA2_OUT_RST | 2 | rw | 0x1 | PL Reset 2 (FCLKRESETN2 output signal). Refer to the PS7 wrapper in EDK for possible signal inversion. Logic level on the FCLKRESETN2 signal: 0: De-assert reset (High logic level). 1: Assert Reset (Low logic state) |
| FPGA1_OUT_RST | 1 | rw | 0x1 | PL Reset 1 (FCLKRESETN1 output signal). Refer to the PS7 wrapper in EDK for possible signal inversion. Logic level on the FCLKRESETN1 signal: 0: De-assert reset (High logic level). 1: Assert Reset (Low logic state) |
| FPGA0_OUT_RST | 0 | rw | 0x1 | PL Reset 0 (FCLKRESETN0 output signal). Refer to the PS7 wrapper in EDK for possible signal inversion. Logic level on the FCLKRESETN0 signal: 0: De-assert reset (High logic level). 1: Assert Reset (Low logic state) |

Register ([slcr](#)) A9_CPU_RST_CTRL

| | |
|------------------|-----------------------------|
| Name | A9_CPU_RST_CTRL |
| Relative Address | 0x00000244 |
| Absolute Address | 0xF8000244 |
| Width | 32 bits |
| Access Type | rw |
| Reset Value | 0x00000000 |
| Description | CPU Reset and Clock control |

Register A9_CPU_RST_CTRL Details

| Field Name | Bits | Type | Reset Value | Description |
|-------------|------|------|-------------|---|
| reserved | 31:9 | rw | 0x0 | Reserved. Writes are ignored, read data is zero. |
| PERI_RST | 8 | rw | 0x0 | CPU peripheral soft reset. 0: de-assert (no reset) 1: assert (held in reset) |
| reserved | 7:6 | rw | 0x0 | Reserved. Writes are ignored, read data is zero. |
| A9_CLKSTOP1 | 5 | rw | 0x0 | CPU 1 clock stop control: 0: no stop (CPU runs) 1: clock stopped |
| A9_CLKSTOP0 | 4 | rw | 0x0 | CPU 0 clock stop control: 0: no stop (CPU runs) 1: clock stopped |
| reserved | 3:2 | rw | 0x0 | Reserved. Writes are ignored, read data is zero. |
| A9_RST1 | 1 | rw | 0x0 | CPU 1 software reset control: 0: de-assert (no reset) 1: assert (held in reset) |
| A9_RST0 | 0 | rw | 0x0 | CPU 0 software reset control: 0: de-assert (no reset) 1: assert (held in reset) |

Register ([slcr](#)) RS_AWDT_CTRL

| | |
|------------------|------------------------------|
| Name | RS_AWDT_CTRL |
| Relative Address | 0x0000024C |
| Absolute Address | 0xF800024C |
| Width | 32 bits |
| Access Type | rw |
| Reset Value | 0x00000000 |
| Description | Watchdog Timer Reset Control |

Register RS_AWDT_CTRL Details

| Field Name | Bits | Type | Reset Value | Description |
|------------|------|------|-------------|--|
| reserved | 31:2 | rw | 0x0 | Reserved. Writes are ignored, read data is zero. |

| Field Name | Bits | Type | Reset Value | Description |
|------------|------|------|-------------|--|
| CTRL1 | 1 | rw | 0x0 | Select the target for the APU watchdog timer 1 reset signal. Route the WDT reset to: 0: the same system level as PS_SRST_B 1: the CPU associated with the watchdog timer |
| CTRL0 | 0 | rw | 0x0 | Select the target for the APU watchdog timer 0 reset signal. Route the WDT reset to: 0: the same system level as PS_SRST_B 1: the CPU associated with the watchdog timer |

Register ([slcr](#)) REBOOT_STATUS

| | |
|------------------|---------------------------|
| Name | REBOOT_STATUS |
| Relative Address | 0x00000258 |
| Absolute Address | 0xF8000258 |
| Width | 32 bits |
| Access Type | rw |
| Reset Value | 0x00400000 |
| Description | Reboot Status, persistent |

Register REBOOT_STATUS Details

The Reboot Status persistent through all resets except Power-on reset.

| Field Name | Bits | Type | Reset Value | Description |
|--------------|-------|------|-------------|--|
| REBOOT_STATE | 31:24 | rw | 0x0 | General 32-bit R/W field to allow software to store information that persists through all resets except power-on reset. This field is reset by POR only. The ROM will put the last known reset reason into this register. |
| reserved | 23 | rw | 0x0 | Reserved. |
| POR | 22 | rw | 0x1 | Last reset was due to POR (power on reset), if set. This field is written by ROM code. |
| SRST_B | 21 | rw | 0x0 | Last reset was due to SRST_B (soft reset), if set. This field is written by ROM code. |
| DBG_RST | 20 | rw | 0x0 | Last reset was due to debug system reset, if set. This field is written by ROM code. |
| SLC_RST | 19 | rw | 0x0 | Last reset was due to SLC soft reset, if set. This field is written by ROM code. |
| AWDT1_RST | 18 | rw | 0x0 | Last reset was due to APU watchdog timer 1, if set. This field is written by ROM code. |
| AWDT0_RST | 17 | rw | 0x0 | Last reset was due to APU watchdog timer 0, if set. This field is written by ROM code. |

| Field Name | Bits | Type | Reset Value | Description |
|--------------------|------|------|-------------|---|
| SWDT_RST | 16 | rw | 0x0 | Last reset was due to system watchdog timeout, if set (see watchdog status for more details). This field is written by ROM code |
| BOOTROM_ERROR_CODE | 15:0 | rw | 0x0 | This field is written by the BootROM to describe errors that occur during the boot process. Refer to the BootROM debug status section in the Zynq-7000 Technical Reference Manual, UG585. |

Register ([slcr](#)) BOOT_MODE

| | |
|------------------|--------------------------|
| Name | BOOT_MODE |
| Relative Address | 0x0000025C |
| Absolute Address | 0xF800025C |
| Width | 32 bits |
| Access Type | mixed |
| Reset Value | x |
| Description | Boot Mode Strapping Pins |

Register BOOT_MODE Details

Boot mode strapping pins are sampled when Power-on Reset deasserts. The logic levels are stored in this register. The explanation of these boot mode pin settings are explained in the boot mode section of the Zynq Technical Reference Manual.

| Field Name | Bits | Type | Reset Value | Description |
|------------|------|------|-------------|--|
| reserved | 31:5 | rw | 0x0 | Reserved. Writes are ignored, read data is zero. |
| PLL_BYPASS | 4 | ro | 0x0 | Boot mode pins are sampled when Power-on Reset deasserts. The logic levels are stored in this register. The PLL_BYPASS pin sets the initial operating mode of all three PLL clocks (Arm, IO and DDR): 0: PLLs are enabled and their outputs are routed to the clock generators 1: PLLs are disabled and bypassed |
| BOOT_MODE | 3:0 | ro | x | Boot mode pins are sampled when Power-on Reset deasserts. The logic levels are stored in this register. The interpretation of these boot mode values are explained in the boot mode section of the Zynq Technical Reference Manual. |

Register ([slcr](#)) APU_CTRL

| | |
|------------------|------------|
| Name | APU_CTRL |
| Relative Address | 0x00000300 |

Absolute Address 0xF8000300
 Width 32 bits
 Access Type rw
 Reset Value 0x00000000
 Description APU Control

Register APU_CTRL Details

| Field Name | Bits | Type | Reset Value | Description |
|--------------|------|------|-------------|---|
| reserved | 31:3 | rw | 0x0 | Reserved. Writes are ignored, read data is zero. |
| CFGSDISABLE | 2 | rw | 0x0 | Disable write access to some system control processor registers, and some GIC registers. Set only. Once set, individual core reset cannot reset this value. This field is reset by POR only. |
| CP15SDISABLE | 1:0 | rw | 0x0 | Disable write access to some system control processor (CP15) registers, in each processor. Set only. Once set, individual core reset cannot reset this value. This field is reset by POR only. |

Register ([slcr](#)) WDT_CLK_SEL

Name WDT_CLK_SEL
 Relative Address 0x00000304
 Absolute Address 0xF8000304
 Width 32 bits
 Access Type rw
 Reset Value 0x00000000
 Description SWDT clock source select

Register WDT_CLK_SEL Details

| Field Name | Bits | Type | Reset Value | Description |
|------------|------|------|-------------|---|
| reserved | 31:1 | rw | 0x0 | Reserved. Writes are ignored, read data is zero. |
| SEL | 0 | rw | 0x0 | System watchdog timer clock source selection: 0: internal clock CPU_1x 1: external clock from PL via EMIO, or from pinout via MIO |

Register ([slcr](#)) TZ_DMA_NS

| | |
|------------------|-----------------------|
| Name | TZ_DMA_NS |
| Relative Address | 0x00000440 |
| Absolute Address | 0xF8000440 |
| Width | 32 bits |
| Access Type | rw |
| Reset Value | 0x00000000 |
| Description | DMAC TrustZone Config |

Register TZ_DMA_NS Details

| Field Name | Bits | Type | Reset Value | Description |
|------------|------|------|-------------|---|
| reserved | 31:1 | rw | 0x0 | Should Be Zero |
| DMAC_NS | 0 | rw | 0x0 | TZ security (connected to boot_manager_ns on DMAC): 0: secure, DMAC operates in the secure state. 1: non-secure, DMAC operates in the non-secure state. |

Register ([slcr](#)) TZ_DMA_IRQ_NS

| | |
|------------------|--------------------------------------|
| Name | TZ_DMA_IRQ_NS |
| Relative Address | 0x00000444 |
| Absolute Address | 0xF8000444 |
| Width | 32 bits |
| Access Type | rw |
| Reset Value | 0x00000000 |
| Description | DMAC TrustZone Config for Interrupts |

Register TZ_DMA_IRQ_NS Details

| Field Name | Bits | Type | Reset Value | Description |
|------------|-------|------|-------------|---|
| reserved | 31:16 | rw | 0x0 | Should Be Zero |
| DMA_IRQ_NS | 15:0 | rw | 0x0 | TZ security (connected to boot_irq_ns on DMAC): 0: secure, DMAC operates in the secure state. 1: non-secure, DMAC interrupt/event bit is in the non-secure state. |

Register ([slcr](#)) TZ_DMA_PERIPH_NS

| | |
|------------------|---------------------------------------|
| Name | TZ_DMA_PERIPH_NS |
| Relative Address | 0x00000448 |
| Absolute Address | 0xF8000448 |
| Width | 32 bits |
| Access Type | rw |
| Reset Value | 0x00000000 |
| Description | DMAC TrustZone Config for Peripherals |

Register TZ_DMA_PERIPH_NS Details

| Field Name | Bits | Type | Reset Value | Description |
|----------------|------|------|-------------|--|
| reserved | 31:4 | rw | 0x0 | Should Be Zero |
| DMAC_PERIPH_NS | 3:0 | rw | 0x0 | TZ security (connected to boot_periph_ns on DMAC): 0: secure, DMAC operates in the secure state. 1: non-secure, reset value: DMAC peripheral i/f is in the non-secure state. |

Register ([slcr](#)) PSS_IDCODE

| | |
|------------------|------------|
| Name | PSS_IDCODE |
| Relative Address | 0x00000530 |
| Absolute Address | 0xF8000530 |
| Width | 32 bits |
| Access Type | ro |
| Reset Value | x |
| Description | PS IDCODE |

Register PSS_IDCODE Details

| Field Name | Bits | Type | Reset Value | Description |
|------------|-------|------|-------------|----------------|
| REVISION | 31:28 | ro | x | Revision code |
| FAMILY | 27:21 | ro | 0x1B | Family code |
| SUBFAMILY | 20:17 | ro | 0x9 | Subfamily code |

| Field Name | Bits | Type | Reset Value | Description |
|-----------------|-------|------|-------------|--|
| DEVICE | 16:12 | ro | x | Device code 7z010: 0x02 7z015: 0x1b 7z020: 0x07 7z030: 0x0c 7z045: 0x11 |
| MANUFACTURER_ID | 11:1 | ro | 0x49 | Manufacturer ID |
| reserved | 0 | ro | 0x1 | Reserved. Writes are ignored, read data is one. |

Register ([slcr](#)) DDR_URGENT

| | |
|------------------|--------------------|
| Name | DDR_URGENT |
| Relative Address | 0x00000600 |
| Absolute Address | 0xF8000600 |
| Width | 32 bits |
| Access Type | rw |
| Reset Value | 0x00000000 |
| Description | DDR Urgent Control |

Register DDR_URGENT Details

| Field Name | Bits | Type | Reset Value | Description |
|-------------|------|------|-------------|----------------------------------|
| reserved | 31:8 | rw | 0x0 | Reserved |
| S3_ARURGENT | 7 | rw | 0x0 | Set Read port 3 prioritization. |
| S2_ARURGENT | 6 | rw | 0x0 | Set Read port 3 prioritization. |
| S1_ARURGENT | 5 | rw | 0x0 | Set Read port 2 prioritization. |
| S0_ARURGENT | 4 | rw | 0x0 | Set Read port 0 prioritization. |
| S3_AWURGENT | 3 | rw | 0x0 | Set Write port 3 prioritization. |
| S2_AWURGENT | 2 | rw | 0x0 | Set Write port 2 prioritization. |
| S1_AWURGENT | 1 | rw | 0x0 | Set Write port 1 prioritization. |
| S0_AWURGENT | 0 | rw | 0x0 | Set Write port 0 prioritization. |

Register ([slcr](#)) DDR_CAL_START

| | |
|------------------|---------------|
| Name | DDR_CAL_START |
| Relative Address | 0x0000060C |
| Absolute Address | 0xF800060C |
| Width | 32 bits |

Access Type mixed
 Reset Value 0x00000000
 Description DDR Calibration Start Triggers

Register DDR_CAL_START Details

| Field Name | Bits | Type | Reset Value | Description |
|-----------------|------|------|-------------|--|
| reserved | 31:2 | rw | 0x0 | Reserved. Writes are ignored, read data is zero. |
| START_CAL_DLL | 1 | wo | 0x0 | This register creates a pulse that is first synchronised into the ddr_clk domain and then directly drives the co_gs_dll_calib input into the DDR controller. This signal is a command that indicates to the controller to issue a dll_calib to the DRAM. This signal should pulse for 1 ddr_core_clk clock cycle to request a dll_calib to be issued. This is only required if the DDR controller register reg_ddrc_dis_dll_calib is 1. If reg_ddrc_dis_dll_calib is 0, the controller will automatically issue DLL Calibs. 0: Do nothing. 1: Start DLL calibration command. A read of this register returns zero. |
| START_CAL_SHORT | 0 | wo | 0x0 | This register creates a pulse that is first synchronized into the ddr_clk domain and then directly drives the co_gs_zq_calib_short input into the DDR controller. This is required to pulse for 1 clock to issue ZQ Calibration Short Command to the DDR. There should be a minimum of 512 clks gap between 2 ZQ Calib Short commands from the core. If DDR controller register reg_ddrc_dis_auto_zq=0, asserting co_gs_zq_calib_short is not required, as this will be done automatically. If reg_ddrc_dis_auto_zq=1, then the core logic is required to assert co_gs_zq_calib_short periodically to update DDR3 ZQ calibration. 0: Do nothing. 1: Start ZQ calibration short command. A read of this register returns zero. |

Register ([slcr](#)) DDR_REF_START

Name DDR_REF_START
 Relative Address 0x00000614
 Absolute Address 0xF8000614
 Width 32 bits
 Access Type mixed
 Reset Value 0x00000000

Description DDR Refresh Start Triggers

Register DDR_REF_START Details

| Field Name | Bits | Type | Reset Value | Description |
|------------|------|------|-------------|--|
| reserved | 31:1 | rw | 0x0 | Reserved. Writes are ignored, read data is zero. |
| START_REF | 0 | wo | 0x0 | <p>This register creates a pulse that is first synchronized into the ddr_clk domain and then directly drives the co_gs_rank_refresh input into the DDR controller. This register must be used with the Virage DRAM controller register bit reg_ddrc_dis_auto_refresh.</p> <p>This signal is a command that indicates to the controller to issue a refresh to the DRAM. One bit per rank. This signal should pulse for 1 ddr_core_clk clock cycle to request a refresh to be issued.</p> <p>0: Do nothing. 1: Start refresh.</p> <p>A read of this register returns zero.</p> |

Register ([slcr](#)) DDR_CMD_STA

Name DDR_CMD_STA
 Relative Address 0x00000618
 Absolute Address 0xF8000618
 Width 32 bits
 Access Type mixed
 Reset Value 0x00000000
 Description DDR Command Store Status

Register DDR_CMD_STA Details

| Field Name | Bits | Type | Reset Value | Description |
|--------------|------|------|-------------|---|
| reserved | 31:1 | rw | 0x0 | Reserved. Writes are ignored, read data is zero. |
| CMD_Q_NEMPTY | 0 | ro | 0x0 | <p>DDR controller command store fill status.</p> <p>0: indicates DDRC command store is empty. 1: indicates there are commands pending in DDRC command store.</p> <p>This register is a continuous monitor of the ddr_co_q_not_empty output from the DDR controller, which is first synchronised from ddr_clk into amba1x_clk.</p> |

Register ([slcr](#)) DDR_URGENT_SEL

| | |
|------------------|-------------------|
| Name | DDR_URGENT_SEL |
| Relative Address | 0x0000061C |
| Absolute Address | 0xF800061C |
| Width | 32 bits |
| Access Type | rw |
| Reset Value | 0x00000000 |
| Description | DDR Urgent Select |

Register DDR_URGENT_SEL Details

| Field Name | Bits | Type | Reset Value | Description |
|---------------|-------|------|-------------|--|
| reserved | 31:16 | rw | 0x0 | Reserved. Writes are ignored, read data is zero. |
| S3_ARQOS_MODE | 15:14 | rw | 0x0 | Selects between the AXI port s3_awqos[3], fabric signal or static register to drive the DDRC urgent bit. 00: DDRC s3_awurgent bit is driven from the 'S3_AWURGENT' field of the DDR_URGENT_VAL register. 01: DDRC s3_awurgent bit is driven from the s3_awqos bit. 10: DDRC s3_awurgent bit is driven from the fabric ddr_arb[3] input. 11: undefined |
| S2_ARQOS_MODE | 13:12 | rw | 0x0 | Selects between the AXI port s2_arqos[3], fabric signal or static register to drive the DDRC urgent bit. 00: DDRC s2_arurgent bit is driven from the 'S2_ARURGENT' field of the DDR_URGENT_VAL register. 01: DDRC s2_arurgent bit is driven from the s2_arqos bit. 10: DDRC s2_arurgent bit is driven from the fabric ddr_arb[2] input. 11: undefined |
| S1_ARQOS_MODE | 11:10 | rw | 0x0 | Selects between the AXI port s1_arqos[3], fabric signal or static register to drive the DDRC urgent bit. 00: DDRC s1_arurgent bit is driven from the 'S1_ARURGENT' field of the DDR_URGENT_VAL register. 01: DDRC s1_arurgent bit is driven from the s1_arqos bit. 10: DDRC s1_arurgent bit is driven from the fabric ddr_arb[1] input. 11: undefined. |

| Field Name | Bits | Type | Reset Value | Description |
|---------------|------|------|-------------|---|
| S0_ARQOS_MODE | 9:8 | rw | 0x0 | Selects between the fabric signal or static register to drive the DDRC urgent bit. 00: DDRC s0_arurgent bit is driven from the 'S0_ARURGENT' field of the DDR_URGENT_VAL register. x1: undefined 10: DDRC s0_arurgent bit is driven from the fabric ddr_arb[0] input. 11: undefined |
| S3_AWQOS_MODE | 7:6 | rw | 0x0 | Selects between the AXI port s3_awqos[3], fabric signal or static register to drive the DDRC urgent bit. 00: DDRC s3_awurgent bit is driven from the 'S3_AWURGENT' field of the DDR_URGENT_VAL register. 01: DDRC s3_awurgent bit is driven from the s3_awqos bit. 10: DDRC s3_awurgent bit is driven from the fabric ddr_arb[3] input. 11: undefined |
| S2_AWQOS_MODE | 5:4 | rw | 0x0 | Selects between the AXI port s2_awqos[3], fabric signal or static register to drive the DDRC urgent bit. 00: DDRC s2_awurgent bit is driven from the 'S2_AWURGENT' field of the DDR_URGENT_VAL register. 01: DDRC s2_awurgent bit is driven from the s2_awqos bit. 10: DDRC s2_awurgent bit is driven from the fabric ddr_arb[2] input. 11: undefined |

| Field Name | Bits | Type | Reset Value | Description |
|---------------|------|------|-------------|---|
| S1_AWQOS_MODE | 3:2 | rw | 0x0 | Selects between the AXI port s1_awqos[3], fabric signal or static register to drive the DDRC urgent bit. 00: DDRC s1_awurgent bit is driven from the 'S1_AWURGENT' field of the DDR_URGENT_VAL register. 01: DDRC s1_awurgent bit is driven from the s1_awqos bit. 10: DDRC s1_awurgent bit is driven from the fabric ddr_arb[1] input. 11: undefined |
| S0_AWQOS_MODE | 1:0 | rw | 0x0 | Selects between the fabric signal or static register to drive the DDRC urgent bit. 00: The DDRC s0_awurgent bit is driven from the 'S0_AWURGENT' field of the DDR_URGENT_VAL register. x1: undefined 10: The DDRC s0_awurgent bit is driven from the fabric ddr_arb[0] input. 11: undefined |

Register ([slcr](#)) DDR_DFI_STATUS

| | |
|------------------|----------------|
| Name | DDR_DFI_STATUS |
| Relative Address | 0x00000620 |
| Absolute Address | 0xF8000620 |
| Width | 32 bits |
| Access Type | mixed |
| Reset Value | 0x00000000 |
| Description | DDR DFI status |

Register DDR_DFI_STATUS Details

| Field Name | Bits | Type | Reset Value | Description |
|------------|------|------|-------------|---|
| reserved | 31:1 | rw | 0x0 | Reserved. Writes are ignored, read data is zero. |
| DFI_CAL_ST | 0 | ro | 0x0 | This signal is intended to allow a calibration of the IOB's at a time when the DDR controller is in its calibration mode, i.e. during an idle period. |

Register ([slcr](#)) MIO_PIN_00

| | |
|------------------|------------|
| Name | MIO_PIN_00 |
| Relative Address | 0x00000700 |

Absolute Address 0xF8000700
 Width 32 bits
 Access Type rw
 Reset Value 0x00001601
 Description MIO Pin 0 Control

Register MIO_PIN_00 Details

| Field Name | Bits | Type | Reset Value | Description |
|-------------|-------|------|-------------|---|
| reserved | 31:14 | rw | 0x0 | reserved |
| DisableRcvr | 13 | rw | 0x0 | Disable HSTL Input Buffer to save power when it is an output-only (IO_Type must be HSTL). 0: enable 1: disable |
| PULLUP | 12 | rw | 0x1 | Enables Pullup on IO Buffer pin 0: disable 1: enable |
| IO_Type | 11:9 | rw | 0x3 | Select the IO Buffer Type. 000: Reserved 001: LVC MOS18 010: LVC MOS25 011: LVC MOS33 100: HSTL 101: Reserved 110: Reserved 111: Reserved |
| Speed | 8 | rw | 0x0 | Select IO Buffer Edge Rate, applicable when IO_Type is LVC MOS18, LVC MOS25 or LVC MOS33. 0: Slow CMOS edge 1: Fast CMOS edge |
| L3_SEL | 7:5 | rw | 0x0 | Level 3 Mux Select 000: GPIO 0 (bank 0), Input/Output others: reserved |
| L2_SEL | 4:3 | rw | 0x0 | Level 2 Mux Select 00: Level 3 Mux 01: SRAM/NOR Chip Select 0, Output 10: NAND Flash Chip Select, Output 11: SDIO 0 Power Control, Output |
| L1_SEL | 2 | rw | 0x0 | Level 1 Mux Select 0: Level 2 Mux 1: reserved |

| Field Name | Bits | Type | Reset Value | Description |
|------------|------|------|-------------|---|
| L0_SEL | 1 | rw | 0x0 | Level 0 Mux Select 0: Level 1 Mux 1: Quad SPI 1 chip select, Output |
| TRI_ENABLE | 0 | rw | 0x1 | Tri-state enable, active high. 0: disable 1: enable |

Register ([slcr](#)) MIO_PIN_01

| | |
|------------------|-------------------|
| Name | MIO_PIN_01 |
| Relative Address | 0x00000704 |
| Absolute Address | 0xF8000704 |
| Width | 32 bits |
| Access Type | rw |
| Reset Value | 0x00001601 |
| Description | MIO Pin 1 Control |

Register MIO_PIN_01 Details

| Field Name | Bits | Type | Reset Value | Description |
|-------------|-------|------|-------------|--|
| reserved | 31:14 | rw | 0x0 | reserved |
| DisableRcvr | 13 | rw | 0x0 | Operates the same as MIO_PIN_00[DisableRcvr] |
| PULLUP | 12 | rw | 0x1 | Operates the same as MIO_PIN_00[PULLUP] |
| IO_Type | 11:9 | rw | 0x3 | Operates the same as MIO_PIN_00[IO_Type] |
| Speed | 8 | rw | 0x0 | Operates the same as MIO_PIN_00[Speed] |
| L3_SEL | 7:5 | rw | 0x0 | Level 3 Mux Select 000: GPIO 1 (bank 0), Input/Output others: reserved |
| L2_SEL | 4:3 | rw | 0x0 | Level 2 Mux Select 00: Level 3 Mux 01: SRAM Address Bit 25, Output 10: SRAM/NOR Chip Select 1, Output 11: SDIO 1 Power Control, Output |
| L1_SEL | 2 | rw | 0x0 | Level 1 Mux Select 0: Level 2 Mux 1: reserved |
| L0_SEL | 1 | rw | 0x0 | Level 0 Mux Select 0: Level 1 Mux 1: Quad SPI 0 Chip Select, Output |
| TRI_ENABLE | 0 | rw | 0x1 | Operates the same as MIO_PIN_00[TRI_ENABLE] |

Register ([slcr](#)) MIO_PIN_02

| | |
|------------------|-------------------|
| Name | MIO_PIN_02 |
| Relative Address | 0x00000708 |
| Absolute Address | 0xF8000708 |
| Width | 32 bits |
| Access Type | rw |
| Reset Value | 0x00000601 |
| Description | MIO Pin 2 Control |

Register MIO_PIN_02 Details

| Field Name | Bits | Type | Reset Value | Description |
|-------------|-------|------|-------------|--|
| reserved | 31:14 | rw | 0x0 | reserved |
| DisableRcvr | 13 | rw | 0x0 | Operates the same as MIO_PIN_00[DisableRcvr] |
| PULLUP | 12 | rw | 0x0 | Operates the same as MIO_PIN_00[PULLUP] |
| IO_Type | 11:9 | rw | 0x3 | Operates the same as MIO_PIN_00[IO_Type] |
| Speed | 8 | rw | 0x0 | Operates the same as MIO_PIN_00[Speed] |
| L3_SEL | 7:5 | rw | 0x0 | Level 3 Mux Select 000: GPIO 2 (bank 0), Input/Output others: reserved |
| L2_SEL | 4:3 | rw | 0x0 | Level 2 Mux Select 00: Level 3 Mux 01: reserved 10: NAND Flash ALEn, Output 11: SDIO 0 Power Control, Output |
| L1_SEL | 2 | rw | 0x0 | Level 1 Mux Select 0: Level 2 Mux 1: Trace Port Data Bit 8, Output |
| L0_SEL | 1 | rw | 0x0 | Level 0 Mux Select 0: Level 1 Mux 1: Quad SPI 0 IO Bit 0, Input/Output |
| TRI_ENABLE | 0 | rw | 0x1 | Operates the same as MIO_PIN_00[TRI_ENABLE] |

Register ([slcr](#)) MIO_PIN_03

| | |
|------------------|------------|
| Name | MIO_PIN_03 |
| Relative Address | 0x0000070C |
| Absolute Address | 0xF800070C |
| Width | 32 bits |
| Access Type | rw |

Reset Value 0x00000601
 Description MIO Pin 3 Control

Register MIO_PIN_03 Details

| Field Name | Bits | Type | Reset Value | Description |
|-------------|-------|------|-------------|--|
| reserved | 31:14 | rw | 0x0 | reserved |
| DisableRcvr | 13 | rw | 0x0 | Operates the same as MIO_PIN_00[DisableRcvr] |
| PULLUP | 12 | rw | 0x0 | Operates the same as MIO_PIN_00[PULLUP] |
| IO_Type | 11:9 | rw | 0x3 | Operates the same as MIO_PIN_00[IO_Type] |
| Speed | 8 | rw | 0x0 | Operates the same as MIO_PIN_00[Speed] |
| L3_SEL | 7:5 | rw | 0x0 | Level 3 Mux Select 000: GPIO 3 (bank 0), Input/Output others: reserved |
| L2_SEL | 4:3 | rw | 0x0 | Level 2 Mux Select 00: Level 3 Mux 01: SRAM/NOR Data bit 0, Input/Output 10: NAND WE_B, Output 11: SDIO 1 Card Power, Output |
| L1_SEL | 2 | rw | 0x0 | Level 1 Mux Select 0: Level 2 Mux 1: Trace Port Data Bit 9, Output |
| L0_SEL | 1 | rw | 0x0 | Level 0 Mux Select 0: Level 1 Mux 1: Quad SPI 0 IO Bit 1, Input/Output |
| TRI_ENABLE | 0 | rw | 0x1 | Operates the same as MIO_PIN_00[TRI_ENABLE] |

Register ([slcr](#)) MIO_PIN_04

Name MIO_PIN_04
 Relative Address 0x00000710
 Absolute Address 0xF8000710
 Width 32 bits
 Access Type rw
 Reset Value 0x00000601
 Description MIO Pin 4 Control

Register MIO_PIN_04 Details

| Field Name | Bits | Type | Reset Value | Description |
|-------------|-------|------|-------------|---|
| reserved | 31:14 | rw | 0x0 | reserved |
| DisableRcvr | 13 | rw | 0x0 | Operates the same as MIO_PIN_00[DisableRcvr] |
| PULLUP | 12 | rw | 0x0 | Operates the same as MIO_PIN_00[PULLUP] |
| IO_Type | 11:9 | rw | 0x3 | Operates the same as MIO_PIN_00[IO_Type] |
| Speed | 8 | rw | 0x0 | Operates the same as MIO_PIN_00[Speed] |
| L3_SEL | 7:5 | rw | 0x0 | Level 3 Mux Select 000: GPIO 4 (bank 0), Input/Output others: reserved |
| L2_SEL | 4:3 | rw | 0x0 | Level 2 Mux Select 00: Level 3 Mux 01: SRAM/NOR Data Bit 1, Input/Output 10: NAND Flash IO Bit 2, Input/Output 11: SDIO 0 Power Control, Output |
| L1_SEL | 2 | rw | 0x0 | Level 1 Mux Select 0: Level 2 Mux 1: Trace Port Data Bit 10, Output |
| L0_SEL | 1 | rw | 0x0 | Level 0 Mux Select 0: Level 1 Mux 1: Quad SPI 0 IO Bit 2, Input/Output |
| TRI_ENABLE | 0 | rw | 0x1 | Operates the same as MIO_PIN_00[TRI_ENABLE] |

Register ([slcr](#)) MIO_PIN_05

| | |
|------------------|-------------------|
| Name | MIO_PIN_05 |
| Relative Address | 0x00000714 |
| Absolute Address | 0xF8000714 |
| Width | 32 bits |
| Access Type | rw |
| Reset Value | 0x00000601 |
| Description | MIO Pin 5 Control |

Register MIO_PIN_05 Details

| Field Name | Bits | Type | Reset Value | Description |
|-------------|-------|------|-------------|--|
| reserved | 31:14 | rw | 0x0 | reserved |
| DisableRcvr | 13 | rw | 0x0 | Operates the same as MIO_PIN_00[DisableRcvr] |
| PULLUP | 12 | rw | 0x0 | Operates the same as MIO_PIN_00[PULLUP] |
| IO_Type | 11:9 | rw | 0x3 | Operates the same as MIO_PIN_00[IO_Type] |

| Field Name | Bits | Type | Reset Value | Description |
|------------|------|------|-------------|--|
| Speed | 8 | rw | 0x0 | Operates the same as MIO_PIN_00[Speed] |
| L3_SEL | 7:5 | rw | 0x0 | Level 3 Mux Select 000: GPIO 5 (bank 0), Input/Output others: reserved |
| L2_SEL | 4:3 | rw | 0x0 | Level 2 Mux Select 00: Level 3 Mux 01: SRAM/NOR Data Bit 2, Input/Output 10: NAND Flash IO Bit 0, Input/Output 11: SDIO 1 Power Control, Output |
| L1_SEL | 2 | rw | 0x0 | Level 1 Mux Select 0: Level 2 Mux 1: Trace Port Data Bit 11, Output |
| L0_SEL | 1 | rw | 0x0 | Level 0 Mux Select 0: Level 1 Mux 1: Quad SPI 0 IO Bit 3, Input/Output |
| TRI_ENABLE | 0 | rw | 0x1 | Operates the same as MIO_PIN_00[TRI_ENABLE] |

Register ([slcr](#)) MIO_PIN_06

| | |
|------------------|-------------------|
| Name | MIO_PIN_06 |
| Relative Address | 0x00000718 |
| Absolute Address | 0xF8000718 |
| Width | 32 bits |
| Access Type | rw |
| Reset Value | 0x00000601 |
| Description | MIO Pin 6 Control |

Register MIO_PIN_06 Details

| Field Name | Bits | Type | Reset Value | Description |
|-------------|-------|------|-------------|--|
| reserved | 31:14 | rw | 0x0 | reserved |
| DisableRcvr | 13 | rw | 0x0 | Operates the same as MIO_PIN_00[DisableRcvr] |
| PULLUP | 12 | rw | 0x0 | Operates the same as MIO_PIN_00[PULLUP] |
| IO_Type | 11:9 | rw | 0x3 | Operates the same as MIO_PIN_00[IO_Type] |
| Speed | 8 | rw | 0x0 | Operates the same as MIO_PIN_00[Speed] |
| L3_SEL | 7:5 | rw | 0x0 | Level 3 Mux Select 000: GPIO 6 (bank 0), Input/Output others: reserved |

| Field Name | Bits | Type | Reset Value | Description |
|------------|------|------|-------------|---|
| L2_SEL | 4:3 | rw | 0x0 | Level 2 Mux Select 00: Level 3 Mux 01: SRAM/NOR Data Bit 3, Input/Output 10: NAND Flash IO Bit 1, Input/Output 11: SDIO 0 Power Control, Output |
| L1_SEL | 2 | rw | 0x0 | Level 1 Mux Select 0: Level 2 Mux 1: Trace Port Data Bit 12, Output |
| L0_SEL | 1 | rw | 0x0 | Level 0 Mux Select 0: Level 1 Mux 1: Quad SPI 0 Clock, Output |
| TRI_ENABLE | 0 | rw | 0x1 | Operates the same as MIO_PIN_00[TRI_ENABLE] |

Register ([slcr](#)) MIO_PIN_07

| | |
|------------------|-------------------|
| Name | MIO_PIN_07 |
| Relative Address | 0x0000071C |
| Absolute Address | 0xF800071C |
| Width | 32 bits |
| Access Type | rw |
| Reset Value | 0x00000601 |
| Description | MIO Pin 7 Control |

Register MIO_PIN_07 Details

| Field Name | Bits | Type | Reset Value | Description |
|-------------|-------|------|-------------|--|
| reserved | 31:14 | rw | 0x0 | reserved |
| DisableRcvr | 13 | rw | 0x0 | Operates the same as MIO_PIN_00[DisableRcvr] |
| PULLUP | 12 | rw | 0x0 | Operates the same as MIO_PIN_00[PULLUP] |
| IO_Type | 11:9 | rw | 0x3 | Operates the same as MIO_PIN_00[IO_Type] |
| Speed | 8 | rw | 0x0 | Operates the same as MIO_PIN_00[Speed] |
| L3_SEL | 7:5 | rw | 0x0 | Level 3 Mux Select 000: GPIO 7 (bank 0), Output-only others: reserved |
| L2_SEL | 4:3 | rw | 0x0 | Level 2 Mux Select 00: Level 3 Mux 01: SRAM/NOR OE_B, Output 10: NAND Flash CLE_B, Output 11: SDIO 1 Power Control, Output |

| Field Name | Bits | Type | Reset Value | Description |
|------------|------|------|-------------|---|
| L1_SEL | 2 | rw | 0x0 | Level 1 Mux Select 0: Level 2 Mux 1: Trace Port Data Bit 13, Output |
| L0_SEL | 1 | rw | 0x0 | Level 0 Mux Select 0: Level 1 Mux 1: reserved |
| TRI_ENABLE | 0 | rw | 0x1 | Operates the same as MIO_PIN_00[TRI_ENABLE] |

Register ([slcr](#)) MIO_PIN_08

| | |
|------------------|-------------------|
| Name | MIO_PIN_08 |
| Relative Address | 0x00000720 |
| Absolute Address | 0xF8000720 |
| Width | 32 bits |
| Access Type | rw |
| Reset Value | 0x00000601 |
| Description | MIO Pin 8 Control |

Register MIO_PIN_08 Details

| Field Name | Bits | Type | Reset Value | Description |
|-------------|-------|------|-------------|---|
| reserved | 31:14 | rw | 0x0 | reserved |
| DisableRcvr | 13 | rw | 0x0 | Operates the same as MIO_PIN_00[DisableRcvr] |
| PULLUP | 12 | rw | 0x0 | Operates the same as MIO_PIN_00[PULLUP] |
| IO_Type | 11:9 | rw | 0x3 | Operates the same as MIO_PIN_00[IO_Type] |
| Speed | 8 | rw | 0x0 | Operates the same as MIO_PIN_00[Speed] |
| L3_SEL | 7:5 | rw | 0x0 | Level 3 Mux Select 000: GPIO 8 (bank 0), Output-only 001: CAN 1 Tx, Output 010: SRAM/NOR BLS_B, Output 011 to 110: reserved 111: UART 1 Tx, Output |
| L2_SEL | 4:3 | rw | 0x0 | Level 2 Mux Select 00: Level 3 Mux 01: reserved 10: NAND Flash RD_B, Output 11: SDIO 0 Power Control, Output |
| L1_SEL | 2 | rw | 0x0 | Level 1 Mux Select 0: Level 2 Mux 1: Trace Port Data Bit 14, Output |

| Field Name | Bits | Type | Reset Value | Description |
|------------|------|------|-------------|--|
| L0_SEL | 1 | rw | 0x0 | Level 0 Mux Select 0: Level 1 Mux 1: Quad SPI Feedback Clock, Output |
| TRI_ENABLE | 0 | rw | 0x1 | Operates the same as MIO_PIN_00[TRI_ENABLE] |

Register ([slcr](#)) MIO_PIN_09

| | |
|------------------|-------------------|
| Name | MIO_PIN_09 |
| Relative Address | 0x00000724 |
| Absolute Address | 0xF8000724 |
| Width | 32 bits |
| Access Type | rw |
| Reset Value | 0x00001601 |
| Description | MIO Pin 9 Control |

Register MIO_PIN_09 Details

| Field Name | Bits | Type | Reset Value | Description |
|-------------|-------|------|-------------|--|
| reserved | 31:14 | rw | 0x0 | reserved |
| DisableRcvr | 13 | rw | 0x0 | Operates the same as MIO_PIN_00[DisableRcvr] |
| PULLUP | 12 | rw | 0x1 | Operates the same as MIO_PIN_00[PULLUP] |
| IO_Type | 11:9 | rw | 0x3 | Operates the same as MIO_PIN_00[IO_Type] |
| Speed | 8 | rw | 0x0 | Operates the same as MIO_PIN_00[Speed] |
| L3_SEL | 7:5 | rw | 0x0 | Level 3 Mux Select 000: GPIO 9 (bank 0), Input/Output 001: CAN 1 Rx, Input 010 to 110: reserved 111: UART 1 RxD, Input |
| L2_SEL | 4:3 | rw | 0x0 | Level 2 Mux Select 00: Level 3 Mux 01: SRAM/NOR Data Bit 6, Input/Output 10: NAND Flash IO Bit 4, Input/Output 11: SDIO 1 Power Control, Output |
| L1_SEL | 2 | rw | 0x0 | Level 1 Mux Select 0: Level 2 Mux 1: Trace Port Data Bit 15, Output |
| L0_SEL | 1 | rw | 0x0 | Level 0 Mux Select 0: Level 1 Mux 1: Quad SPI 1 Flash Memory Clock, Output |
| TRI_ENABLE | 0 | rw | 0x1 | Operates the same as MIO_PIN_00[TRI_ENABLE] |

Register ([slcr](#)) MIO_PIN_10

| | |
|------------------|--------------------|
| Name | MIO_PIN_10 |
| Relative Address | 0x00000728 |
| Absolute Address | 0xF8000728 |
| Width | 32 bits |
| Access Type | rw |
| Reset Value | 0x00001601 |
| Description | MIO Pin 10 Control |

Register MIO_PIN_10 Details

| Field Name | Bits | Type | Reset Value | Description |
|-------------|-------|------|-------------|---|
| reserved | 31:14 | rw | 0x0 | reserved |
| DisableRcvr | 13 | rw | 0x0 | Operates the same as MIO_PIN_00[DisableRcvr] |
| PULLUP | 12 | rw | 0x1 | Operates the same as MIO_PIN_00[PULLUP] |
| IO_Type | 11:9 | rw | 0x3 | Operates the same as MIO_PIN_00[IO_Type] |
| Speed | 8 | rw | 0x0 | Operates the same as MIO_PIN_00[Speed] |
| L3_SEL | 7:5 | rw | 0x0 | Level 3 Mux Select 000: GPIO 10 (bank 0), Input/Output 001: CAN 0 Rx, Input 010: I2C 0 Serial Clock, Input/Output 011: PJTAG TDI, Input 100: SDIO 1 IO Bit 0, Input/Output 101: SPI 1 MOSI, Input/Output 110: reserved 111: UART 0 RxD, Input |
| L2_SEL | 4:3 | rw | 0x0 | Level 2 Mux Select 00: Level 3 Mux 01: SRAM/NOR Data Bit 7, Input/Output 10: NAND Flash IO Bit 5, Input/Output 11: SDIO 0 Power Control, Output |
| L1_SEL | 2 | rw | 0x0 | Level 1 Mux Select 0: Level 2 Mux 1: Trace Port Data Bit 2, Output |
| L0_SEL | 1 | rw | 0x0 | Level 0 Mux Select 0: Level 1 Mux 1: Quad SPI 1 IO Bit 0, Input/Output |
| TRI_ENABLE | 0 | rw | 0x1 | Operates the same as MIO_PIN_00[TRI_ENABLE] |

Register ([slcr](#)) MIO_PIN_11

| | |
|------------------|--------------------|
| Name | MIO_PIN_11 |
| Relative Address | 0x0000072C |
| Absolute Address | 0xF800072C |
| Width | 32 bits |
| Access Type | rw |
| Reset Value | 0x00001601 |
| Description | MIO Pin 11 Control |

Register MIO_PIN_11 Details

| Field Name | Bits | Type | Reset Value | Description |
|-------------|-------|------|-------------|--|
| reserved | 31:14 | rw | 0x0 | reserved |
| DisableRcvr | 13 | rw | 0x0 | Operates the same as MIO_PIN_00[DisableRcvr] |
| PULLUP | 12 | rw | 0x1 | Operates the same as MIO_PIN_00[PULLUP] |
| IO_Type | 11:9 | rw | 0x3 | Operates the same as MIO_PIN_00[IO_Type] |
| Speed | 8 | rw | 0x0 | Operates the same as MIO_PIN_00[Speed] |
| L3_SEL | 7:5 | rw | 0x0 | Level 3 Mux Select 000: GPIO 11 (bank 0), Input/Output 001: CAN 0 Tx, Output 010: I2C 0 Serial Data, Input/Output 011: PJTAG TDO, Output 100: SDIO 1 Command, Input/Output 101: SPI 1 MISO, Input/Output 110: reserved 111: UART 0 TxD, Output |
| L2_SEL | 4:3 | rw | 0x0 | Level 2 Mux Select 00: Level 3 Mux 01: SRAM/NOR Data Bit 4, Input/Output 10: NAND Flash IO Bit 6, Input/Output 11: SDIO 1 Power Control, Output |
| L1_SEL | 2 | rw | 0x0 | Level 1 Mux Select 0: Level 2 Mux 1: Trace Port Data Bit 3, Output |
| L0_SEL | 1 | rw | 0x0 | Level 0 Mux Select 0: Level 1 Mux 1: Quad SPI 1 IO Bit 1, Input/Output |
| TRI_ENABLE | 0 | rw | 0x1 | Operates the same as MIO_PIN_00[TRI_ENABLE] |

Register ([slcr](#)) MIO_PIN_12

| | |
|------------------|--------------------|
| Name | MIO_PIN_12 |
| Relative Address | 0x00000730 |
| Absolute Address | 0xF8000730 |
| Width | 32 bits |
| Access Type | rw |
| Reset Value | 0x00001601 |
| Description | MIO Pin 12 Control |

Register MIO_PIN_12 Details

| Field Name | Bits | Type | Reset Value | Description |
|-------------|-------|------|-------------|---|
| reserved | 31:14 | rw | 0x0 | reserved |
| DisableRcvr | 13 | rw | 0x0 | Operates the same as MIO_PIN_00[DisableRcvr] |
| PULLUP | 12 | rw | 0x1 | Operates the same as MIO_PIN_00[PULLUP] |
| IO_Type | 11:9 | rw | 0x3 | Operates the same as MIO_PIN_00[IO_Type] |
| Speed | 8 | rw | 0x0 | Operates the same as MIO_PIN_00[Speed] |
| L3_SEL | 7:5 | rw | 0x0 | Level 3 Mux Select 000: GPIO 12 (bank 0), Input/Output 001: CAN 1 Tx, Output 010: I2C 1 Serial Clock, Input/Output 011: PJTAG TCK, Input 100: SDIO 1 Clock, Input/Output 101: SPI 1 Serial Clock, Input/Output 110: reserved 111: UART 1 Tx/D, Output |
| L2_SEL | 4:3 | rw | 0x0 | Level 2 Mux Select 00: Level 3 Mux 01: reserved 10: NAND Flash IO Bit 7, Input/Output 11: SDIO 0 Power Control, Output |
| L1_SEL | 2 | rw | 0x0 | Level 1 Mux Select 0: Level 2 Mux 1: Trace Port Clock, Output |
| L0_SEL | 1 | rw | 0x0 | Level 0 Mux Select 0: Level 1 Mux 1: Quad SPI 1 IO Bit 2, Input/Output |
| TRI_ENABLE | 0 | rw | 0x1 | Operates the same as MIO_PIN_00[TRI_ENABLE] |

Register ([slcr](#)) MIO_PIN_13

| | |
|------------------|--------------------|
| Name | MIO_PIN_13 |
| Relative Address | 0x00000734 |
| Absolute Address | 0xF8000734 |
| Width | 32 bits |
| Access Type | rw |
| Reset Value | 0x00001601 |
| Description | MIO Pin 13 Control |

Register MIO_PIN_13 Details

| Field Name | Bits | Type | Reset Value | Description |
|-------------|-------|------|-------------|---|
| reserved | 31:14 | rw | 0x0 | reserved |
| DisableRcvr | 13 | rw | 0x0 | Operates the same as MIO_PIN_00[DisableRcvr] |
| PULLUP | 12 | rw | 0x1 | Operates the same as MIO_PIN_00[PULLUP] |
| IO_Type | 11:9 | rw | 0x3 | Operates the same as MIO_PIN_00[IO_Type] |
| Speed | 8 | rw | 0x0 | Operates the same as MIO_PIN_00[Speed] |
| L3_SEL | 7:5 | rw | 0x0 | Level 3 Mux Select 000: GPIO 13 (bank 0), Input/Output 001: CAN 1 Rx, Input 010: I2C 1 Serial Data, Input/Output 011: PJTAG TMS, Input 100: SDIO 1 IO Bit 1, Input/Output 101: SPI 1 Slave Select 0, Input/Output 110: reserved 111: UART 1 Rx/D, Input |
| L2_SEL | 4:3 | rw | 0x0 | Level 2 Mux Select 00: Level 3 Mux 01: SRAM/NOR Data Bit 5, Input/Output 10: NAND Flash IO Bit 3, Input/Output 11: SDIO 1 Power Control, Output |
| L1_SEL | 2 | rw | 0x0 | Level 1 Mux Select 0: Level 2 Mux 1: Trace Port Control Signal, Output |
| L0_SEL | 1 | rw | 0x0 | Level 0 Mux Select 0: Level 1 Mux 1: Quad SPI 1 IO Bit 3, Input/Output |
| TRI_ENABLE | 0 | rw | 0x1 | Operates the same as MIO_PIN_00[TRI_ENABLE] |

Register ([slcr](#)) MIO_PIN_14

| | |
|------------------|--------------------|
| Name | MIO_PIN_14 |
| Relative Address | 0x00000738 |
| Absolute Address | 0xF8000738 |
| Width | 32 bits |
| Access Type | rw |
| Reset Value | 0x00001601 |
| Description | MIO Pin 14 Control |

Register MIO_PIN_14 Details

| Field Name | Bits | Type | Reset Value | Description |
|-------------|-------|------|-------------|--|
| reserved | 31:14 | rw | 0x0 | reserved |
| DisableRcvr | 13 | rw | 0x0 | Operates the same as MIO_PIN_00[DisableRcvr] |
| PULLUP | 12 | rw | 0x1 | Operates the same as MIO_PIN_00[PULLUP] |
| IO_Type | 11:9 | rw | 0x3 | Operates the same as MIO_PIN_00[IO_Type] |
| Speed | 8 | rw | 0x0 | Operates the same as MIO_PIN_00[Speed] |
| L3_SEL | 7:5 | rw | 0x0 | Level 3 Mux Select 000: GPIO 14 (bank 0), Input/Output 001: CAN 0 Rx, Input 010: I2C 0 Serial Clock, Input/Output 011: SWDT Clock, Input 100: SDIO 1 IO Bit 2, Input/Output 101: SPI 1 slave select 1, Output 110: reserved 111: UART 0 RxD, Input |
| L2_SEL | 4:3 | rw | 0x0 | Level 2 Mux Select 00: Level 3 Mux 01: reserved 10: NAND Flash Busy, Input 11: SDIO 0 Power Control, Output |
| L1_SEL | 2 | rw | 0x0 | Level 1 Mux Select 0: Level 2 Mux 1: Trace Port Data Bit 0, Output |
| L0_SEL | 1 | rw | 0x0 | Level 0 Mux Select 0: Level 1 Mux 1= Not Used |
| TRI_ENABLE | 0 | rw | 0x1 | Operates the same as MIO_PIN_00[TRI_ENABLE] |

Register ([slcr](#)) MIO_PIN_15

| | |
|------------------|--------------------|
| Name | MIO_PIN_15 |
| Relative Address | 0x0000073C |
| Absolute Address | 0xF800073C |
| Width | 32 bits |
| Access Type | rw |
| Reset Value | 0x00001601 |
| Description | MIO Pin 15 Control |

Register MIO_PIN_15 Details

| Field Name | Bits | Type | Reset Value | Description |
|-------------|-------|------|-------------|---|
| reserved | 31:14 | rw | 0x0 | reserved |
| DisableRcvr | 13 | rw | 0x0 | Operates the same as MIO_PIN_00[DisableRcvr] |
| PULLUP | 12 | rw | 0x1 | Operates the same as MIO_PIN_00[PULLUP] |
| IO_Type | 11:9 | rw | 0x3 | Operates the same as MIO_PIN_00[IO_Type] |
| Speed | 8 | rw | 0x0 | Operates the same as MIO_PIN_00[Speed] |
| L3_SEL | 7:5 | rw | 0x0 | Level 3 Mux Select 000: GPIO 15 (bank 0), Input/Output 001: CAN 0 Tx, Output 010: I2C 0 Serial Data, Input/Output 011: SWDT Reset, Output 100: SDIO 1 IO Bit 3, Input/Output 101: SPI 1 Slave Select 2, Output 110: reserved 111: UART 0 Tx, Output |
| L2_SEL | 4:3 | rw | 0x0 | Level 2 Mux Select 00: Level 3 Mux 01: SRAM/NOR Address Bit 0, Output 10: reserved 11: SDIO 1 Power Control, Output |
| L1_SEL | 2 | rw | 0x0 | Level 1 Mux Select 0: Level 2 Mux 1: Trace Port Data Bit 1, Output |
| L0_SEL | 1 | rw | 0x0 | Level 0 Mux Select 0: Level 1 Mux 1= Not Used |
| TRI_ENABLE | 0 | rw | 0x1 | Operates the same as MIO_PIN_00[TRI_ENABLE] |

Register ([slcr](#)) MIO_PIN_16

| | |
|------------------|--------------------|
| Name | MIO_PIN_16 |
| Relative Address | 0x00000740 |
| Absolute Address | 0xF8000740 |
| Width | 32 bits |
| Access Type | rw |
| Reset Value | 0x00001601 |
| Description | MIO Pin 16 Control |

Register MIO_PIN_16 Details

| Field Name | Bits | Type | Reset Value | Description |
|-------------|-------|------|-------------|---|
| reserved | 31:14 | rw | 0x0 | reserved |
| DisableRcvr | 13 | rw | 0x0 | Operates the same as MIO_PIN_00[DisableRcvr] |
| PULLUP | 12 | rw | 0x1 | Operates the same as MIO_PIN_00[PULLUP] |
| IO_Type | 11:9 | rw | 0x3 | Operates the same as MIO_PIN_00[IO_Type] |
| Speed | 8 | rw | 0x0 | Operates the same as MIO_PIN_00[Speed] |
| L3_SEL | 7:5 | rw | 0x0 | Level 3 Mux Select 000: GPIO 16 (bank 0), Input/Output 001: CAN 1 Tx, Output 010: I2C 1 Serial Clock, Input/Output 011: reserved 100: SDIO 0 Clock, Input/Output 101: SPI 0 Serial Clock, Input/Output 110: TTC 1 Wave, Output 111: UART 1 Tx, Output |
| L2_SEL | 4:3 | rw | 0x0 | Level 2 Mux Select 00: Level 3 Mux 01: SRAM/NOR Address Bit 1, Output 10: NAND Flash IO Bit 8, Input/Output 11: SDIO 0 Power Control, Output |
| L1_SEL | 2 | rw | 0x0 | Level 1 Mux Select 0: Level 2 Mux 1: Trace Port Data Bit 4, Output |
| L0_SEL | 1 | rw | 0x0 | Level 0 Mux Select 0: Level 1 Mux 1: Ethernet 0 RGMII Tx Clock, Output |
| TRI_ENABLE | 0 | rw | 0x1 | Operates the same as MIO_PIN_00[TRI_ENABLE] |

Register ([slcr](#)) MIO_PIN_17

| | |
|------------------|--------------------|
| Name | MIO_PIN_17 |
| Relative Address | 0x00000744 |
| Absolute Address | 0xF8000744 |
| Width | 32 bits |
| Access Type | rw |
| Reset Value | 0x00001601 |
| Description | MIO Pin 17 Control |

Register MIO_PIN_17 Details

| Field Name | Bits | Type | Reset Value | Description |
|-------------|-------|------|-------------|--|
| reserved | 31:14 | rw | 0x0 | reserved |
| DisableRcvr | 13 | rw | 0x0 | Operates the same as MIO_PIN_00[DisableRcvr] |
| PULLUP | 12 | rw | 0x1 | Operates the same as MIO_PIN_00[PULLUP] |
| IO_Type | 11:9 | rw | 0x3 | Operates the same as MIO_PIN_00[IO_Type] |
| Speed | 8 | rw | 0x0 | Operates the same as MIO_PIN_00[Speed] |
| L3_SEL | 7:5 | rw | 0x0 | Level 3 Mux Select 000: GPIO 17 (bank 0), Input/Output 001: CAN 1 Rx, Input 010: I2C 1 Serial Data, Input/Output 011: reserved 100: SDIO 0 Command, Input/Output 101: SPI 0 MISO, Input/Output 110 TTC 1 Clock, Input 111: UART 1 RxD, Input |
| L2_SEL | 4:3 | rw | 0x0 | Level 2 Mux Select 00: Level 3 Mux 01: SRAM/NOR Address Bit 2, Output 10: NAND Flash IO Bit 9, Input/Output 11: SDIO 1 Power Control, Output |
| L1_SEL | 2 | rw | 0x0 | Level 1 Mux Select 0: Level 2 Mux 1: Trace Port Data Bit 5, Output |
| L0_SEL | 1 | rw | 0x0 | Level 0 Mux Select 0: Level 1 Mux 1: Ethernet 0 RGMII TxD Bit 0, Output |
| TRI_ENABLE | 0 | rw | 0x1 | Operates the same as MIO_PIN_00[TRI_ENABLE] |

Register ([slcr](#)) MIO_PIN_18

| | |
|------------------|--------------------|
| Name | MIO_PIN_18 |
| Relative Address | 0x00000748 |
| Absolute Address | 0xF8000748 |
| Width | 32 bits |
| Access Type | rw |
| Reset Value | 0x00001601 |
| Description | MIO Pin 18 Control |

Register MIO_PIN_18 Details

| Field Name | Bits | Type | Reset Value | Description |
|-------------|-------|------|-------------|---|
| reserved | 31:14 | rw | 0x0 | reserved |
| DisableRcvr | 13 | rw | 0x0 | Operates the same as MIO_PIN_00[DisableRcvr] |
| PULLUP | 12 | rw | 0x1 | Operates the same as MIO_PIN_00[PULLUP] |
| IO_Type | 11:9 | rw | 0x3 | Operates the same as MIO_PIN_00[IO_Type] |
| Speed | 8 | rw | 0x0 | Operates the same as MIO_PIN_00[Speed] |
| L3_SEL | 7:5 | rw | 0x0 | Level 3 Mux Select 000: GPIO 18 (bank 0), Input/Output 001: CAN 0 Rx, Input 010: I2C 0 Serial Clock, Input/Output 011: reserved 100: SDIO 0 IO Bit 0, Input/Output 101: SPI 0 Slave Select 0, Input/Output 110: TTC 0 Wave, Output 111: UART 0 RxD, Input |
| L2_SEL | 4:3 | rw | 0x0 | Level 2 Mux Select 00: Level 3 Mux 01: SRAM/NOR Address Bit 3, Output 10: NAND Flash IO Bit 10, Input/Output 11: SDIO 0 Power Control, Output |
| L1_SEL | 2 | rw | 0x0 | Level 1 Mux Select 0: Level 2 Mux 1: Trace Port Data Bit 6, Output |
| L0_SEL | 1 | rw | 0x0 | Level 0 Mux Select 0: Level 1 Mux 1: Ethernet 0 RGMII TxD Bit 1, Output |
| TRI_ENABLE | 0 | rw | 0x1 | Operates the same as MIO_PIN_00[TRI_ENABLE] |

Register ([slcr](#)) MIO_PIN_19

| | |
|------------------|--------------------|
| Name | MIO_PIN_19 |
| Relative Address | 0x0000074C |
| Absolute Address | 0xF800074C |
| Width | 32 bits |
| Access Type | rw |
| Reset Value | 0x00001601 |
| Description | MIO Pin 19 Control |

Register MIO_PIN_19 Details

| Field Name | Bits | Type | Reset Value | Description |
|-------------|-------|------|-------------|--|
| reserved | 31:14 | rw | 0x0 | reserved |
| DisableRcvr | 13 | rw | 0x0 | Operates the same as MIO_PIN_00[DisableRcvr] |
| PULLUP | 12 | rw | 0x1 | Operates the same as MIO_PIN_00[PULLUP] |
| IO_Type | 11:9 | rw | 0x3 | Operates the same as MIO_PIN_00[IO_Type] |
| Speed | 8 | rw | 0x0 | Operates the same as MIO_PIN_00[Speed] |
| L3_SEL | 7:5 | rw | 0x0 | Level 3 Mux Select 000: GPIO 19 (bank 0), Input/Output 001: CAN 0 Tx, Output 010: I2C 0 Serial Data, Input/Output 011: reserved 100: SDIO 0 IO Bit 1, Input/Output 101: SPI 0 Slave Select 1, Output 110: TTC 0 Clock, Input 111: UART 0 TxD, Output |
| L2_SEL | 4:3 | rw | 0x0 | Level 2 Mux Select 00: Level 3 Mux 01: SRAM/NOR Address Bit 4, Output 10: NAND Flash IO Bit 11, Input/Output 11: SDIO 1 Power Control, Output |
| L1_SEL | 2 | rw | 0x0 | Level 1 Mux Select 0: Level 2 Mux 1: Trace Port Data Bit 7, Output |
| L0_SEL | 1 | rw | 0x0 | Level 0 Mux Select 0: Level 1 Mux 1: Ethernet 0 RGMII TxD Bit 2, Output |
| TRI_ENABLE | 0 | rw | 0x1 | Operates the same as MIO_PIN_00[TRI_ENABLE] |

Register ([slcr](#)) MIO_PIN_20

| | |
|------------------|--------------------|
| Name | MIO_PIN_20 |
| Relative Address | 0x00000750 |
| Absolute Address | 0xF8000750 |
| Width | 32 bits |
| Access Type | rw |
| Reset Value | 0x00001601 |
| Description | MIO Pin 20 Control |

Register MIO_PIN_20 Details

| Field Name | Bits | Type | Reset Value | Description |
|-------------|-------|------|-------------|---|
| reserved | 31:14 | rw | 0x0 | reserved |
| DisableRcvr | 13 | rw | 0x0 | Operates the same as MIO_PIN_00[DisableRcvr] |
| PULLUP | 12 | rw | 0x1 | Operates the same as MIO_PIN_00[PULLUP] |
| IO_Type | 11:9 | rw | 0x3 | Operates the same as MIO_PIN_00[IO_Type] |
| Speed | 8 | rw | 0x0 | Operates the same as MIO_PIN_00[Speed] |
| L3_SEL | 7:5 | rw | 0x0 | Level 3 Mux Select 000: GPIO 20 (bank 0), Input/Output 001: CAN 1 Tx, Output 010: I2C 1 Serial Clock, Input/Output 011: reserved 100: SDIO 0 IO Bit 2, Input/Output 101: SPI 0 Slave Select 2, Output 110: reserved 111: UART 1 TxD, Output |
| L2_SEL | 4:3 | rw | 0x0 | Level 2 Mux Select 00: Level 3 Mux 01: SRAM/NOR Address Bit 5, Output 10: NAND Flash IO Bit 12, Input/Output 11: SDIO 0 Power Control, Output |
| L1_SEL | 2 | rw | 0x0 | Level 1 Mux Select 0: Level 2 Mux 1: reserved |
| L0_SEL | 1 | rw | 0x0 | Level 0 Mux Select 0: Level 1 Mux 1: Ethernet 0 RGMII TxD Bit 3, Output |
| TRI_ENABLE | 0 | rw | 0x1 | Operates the same as MIO_PIN_00[TRI_ENABLE] |

Register ([slcr](#)) MIO_PIN_21

| | |
|------------------|--------------------|
| Name | MIO_PIN_21 |
| Relative Address | 0x00000754 |
| Absolute Address | 0xF8000754 |
| Width | 32 bits |
| Access Type | rw |
| Reset Value | 0x00001601 |
| Description | MIO Pin 21 Control |

Register MIO_PIN_21 Details

| Field Name | Bits | Type | Reset Value | Description |
|-------------|-------|------|-------------|--|
| reserved | 31:14 | rw | 0x0 | reserved |
| DisableRcvr | 13 | rw | 0x0 | Operates the same as MIO_PIN_00[DisableRcvr] |
| PULLUP | 12 | rw | 0x1 | Operates the same as MIO_PIN_00[PULLUP] |
| IO_Type | 11:9 | rw | 0x3 | Operates the same as MIO_PIN_00[IO_Type] |
| Speed | 8 | rw | 0x0 | Operates the same as MIO_PIN_00[Speed] |
| L3_SEL | 7:5 | rw | 0x0 | Level 3 Mux Select 000: GPIO 21 (bank 0), Input/Output 001: CAN 1 Rx, Input 010: I2C 1 Serial Data, Input/Output 011: reserved 100: SDIO 0 IO Bit 3, Input/Output 101: SPI 0 MOSI, Input/Output 110: reserved 111: UART 1 RxD, Input |
| L2_SEL | 4:3 | rw | 0x0 | Level 2 Mux Select 00: Level 3 Mux 01: SRAM/NOR Address Bit 6, Output 10: NAND Flash IO Bit 13, Input/Output 11: SDIO 1 Power Control, Output |
| L1_SEL | 2 | rw | 0x0 | Level 1 Mux Select 0: Level 2 Mux 1: reserved |
| L0_SEL | 1 | rw | 0x0 | Level 0 Mux Select 0: Level 1 Mux 1: Ethernet 0 RGMII Tx Control, Output |
| TRI_ENABLE | 0 | rw | 0x1 | Operates the same as MIO_PIN_00[TRI_ENABLE] |

Register ([slcr](#)) MIO_PIN_22

| | |
|------------------|--------------------|
| Name | MIO_PIN_22 |
| Relative Address | 0x00000758 |
| Absolute Address | 0xF8000758 |
| Width | 32 bits |
| Access Type | rw |
| Reset Value | 0x00001601 |
| Description | MIO Pin 22 Control |

Register MIO_PIN_22 Details

| Field Name | Bits | Type | Reset Value | Description |
|-------------|-------|------|-------------|---|
| reserved | 31:14 | rw | 0x0 | reserved |
| DisableRcvr | 13 | rw | 0x0 | Operates the same as MIO_PIN_00[DisableRcvr] |
| PULLUP | 12 | rw | 0x1 | Operates the same as MIO_PIN_00[PULLUP] |
| IO_Type | 11:9 | rw | 0x3 | Operates the same as MIO_PIN_00[IO_Type] |
| Speed | 8 | rw | 0x0 | Operates the same as MIO_PIN_00[Speed] |
| L3_SEL | 7:5 | rw | 0x0 | Level 3 Mux Select 000: GPIO 22 (bank 0), Input/Output 001: CAN 0 Rx, Input 010: I2C 0 Serial Clock, Input/Output 011: PJTAG TDI, Input 100: SDIO 1 IO Bit 0, Input/Output 101: SPI 1 MOSI, Input/Output 110: reserved 111: UART 0 RxD, Input |
| L2_SEL | 4:3 | rw | 0x0 | Level 2 Mux Select 00: Level 3 Mux 01: SRAM/NOR Address Bit 7, Output 10: NAND Flash IO Bit 14, Input/Output 11: SDIO 0 Power Control, Output |
| L1_SEL | 2 | rw | 0x0 | Level 1 Mux Select 0: Level 2 Mux 1: Trace Port Data Bit 2, Output |
| L0_SEL | 1 | rw | 0x0 | Level 0 Mux Select 0: Level 1 Mux 1: Ethernet 0 RGMII Rx Clock, Input |
| TRI_ENABLE | 0 | rw | 0x1 | Operates the same as MIO_PIN_00[TRI_ENABLE] |

Register ([slcr](#)) MIO_PIN_23

| | |
|------------------|--------------------|
| Name | MIO_PIN_23 |
| Relative Address | 0x0000075C |
| Absolute Address | 0xF800075C |
| Width | 32 bits |
| Access Type | rw |
| Reset Value | 0x00001601 |
| Description | MIO Pin 23 Control |

Register MIO_PIN_23 Details

| Field Name | Bits | Type | Reset Value | Description |
|-------------|-------|------|-------------|---|
| reserved | 31:14 | rw | 0x0 | reserved |
| DisableRcvr | 13 | rw | 0x0 | Operates the same as MIO_PIN_00[DisableRcvr] |
| PULLUP | 12 | rw | 0x1 | Operates the same as MIO_PIN_00[PULLUP] |
| IO_Type | 11:9 | rw | 0x3 | Operates the same as MIO_PIN_00[IO_Type] |
| Speed | 8 | rw | 0x0 | Operates the same as MIO_PIN_00[Speed] |
| L3_SEL | 7:5 | rw | 0x0 | Level 3 Mux Select 000: GPIO 23 (bank 0), Input/Output 001: CAN 0 Tx, Output 010: I2C 0 Serial Data, Input/Output 011: PJTAG TDO, Output 100: SDIO 1 Command, Input/Output 101: SPI 1 MISO, Input/Output 110: reserved 111: UART 0 Tx/D, Output |
| L2_SEL | 4:3 | rw | 0x0 | Level 2 Mux Select 00: Level 3 Mux 01: SRAM/NOR Address Bit 8, Output 10: NAND Flash IO Bit 15, Input/Output 11: SDIO 1 Power Control, Output |
| L1_SEL | 2 | rw | 0x0 | Level 1 Mux Select 0: Level 2 Mux 1: Trace Port Data Bit 3, Output |
| L0_SEL | 1 | rw | 0x0 | Level 0 Mux Select 0: Level 1 Mux 1: Ethernet 0 RGMII Rx/D 0, Input |
| TRI_ENABLE | 0 | rw | 0x1 | Operates the same as MIO_PIN_00[TRI_ENABLE] |

Register ([slcr](#)) MIO_PIN_24

| | |
|------------------|--------------------|
| Name | MIO_PIN_24 |
| Relative Address | 0x00000760 |
| Absolute Address | 0xF8000760 |
| Width | 32 bits |
| Access Type | rw |
| Reset Value | 0x00001601 |
| Description | MIO Pin 24 Control |

Register MIO_PIN_24 Details

| Field Name | Bits | Type | Reset Value | Description |
|-------------|-------|------|-------------|---|
| reserved | 31:14 | rw | 0x0 | reserved |
| DisableRcvr | 13 | rw | 0x0 | Operates the same as MIO_PIN_00[DisableRcvr] |
| PULLUP | 12 | rw | 0x1 | Operates the same as MIO_PIN_00[PULLUP] |
| IO_Type | 11:9 | rw | 0x3 | Operates the same as MIO_PIN_00[IO_Type] |
| Speed | 8 | rw | 0x0 | Operates the same as MIO_PIN_00[Speed] |
| L3_SEL | 7:5 | rw | 0x0 | Level 3 Mux Select 000: GPIO 24 (bank 0), Input/Output 001: CAN 1 Tx, Output 010: I2C 1 Serial Clock, Input/Output 011: PJTAG TCK, Input 100: SDIO 1 Clock, Input/Output 101: SPI 1 Serial Clock, Input/Output 110: reserved 111: UART 1 Tx/D, Output |
| L2_SEL | 4:3 | rw | 0x0 | Level 2 Mux Select 00: Level 3 Mux 01: SRAM/NOR Address Bit 9, Output 10: reserved 11: SDIO 0 Power Control, Output |
| L1_SEL | 2 | rw | 0x0 | Level 1 Mux Select 0: Level 2 Mux 1: Trace Port Clock output, Output |
| L0_SEL | 1 | rw | 0x0 | Level 0 Mux Select 0: Level 1 Mux 1: Ethernet 0 RGMII Rx/D Bit 1, Input |
| TRI_ENABLE | 0 | rw | 0x1 | Operates the same as MIO_PIN_00[TRI_ENABLE] |

Register ([slcr](#)) MIO_PIN_25

| | |
|------------------|--------------------|
| Name | MIO_PIN_25 |
| Relative Address | 0x00000764 |
| Absolute Address | 0xF8000764 |
| Width | 32 bits |
| Access Type | rw |
| Reset Value | 0x00001601 |
| Description | MIO Pin 25 Control |

Register MIO_PIN_25 Details

| Field Name | Bits | Type | Reset Value | Description |
|-------------|-------|------|-------------|--|
| reserved | 31:14 | rw | 0x0 | reserved |
| DisableRcvr | 13 | rw | 0x0 | Operates the same as MIO_PIN_00[DisableRcvr] |
| PULLUP | 12 | rw | 0x1 | Operates the same as MIO_PIN_00[PULLUP] |
| IO_Type | 11:9 | rw | 0x3 | Operates the same as MIO_PIN_00[IO_Type] |
| Speed | 8 | rw | 0x0 | Operates the same as MIO_PIN_00[Speed] |
| L3_SEL | 7:5 | rw | 0x0 | Level 3 Mux Select 000: GPIO 25 (bank 0), Input/Output 001: CAN 1 Rx, Input 010: I2C 1 Serial Data, Input/Output 011: PJTAG TMS, Input 100: SDIO 1 IO Bit 1, Input/Output 101: SPI 1 Slave Select 0, Input/Output 110: reserved 111: UART 1 RxD, Input |
| L2_SEL | 4:3 | rw | 0x0 | Level 2 Mux Select 00: Level 3 Mux 01: SRAM/NOR Address Bit 10, Output 10: reserved 11: SDIO 1 Power Control, Output |
| L1_SEL | 2 | rw | 0x0 | Level 1 Mux Select 0: Level 2 Mux 1: Trace Port Control Signal, Output |
| L0_SEL | 1 | rw | 0x0 | Level 0 Mux Select 0: Level 1 Mux 1: Ethernet 0 RGMII RxD Bit2, Input |
| TRI_ENABLE | 0 | rw | 0x1 | Operates the same as MIO_PIN_00[TRI_ENABLE] |

Register ([slcr](#)) MIO_PIN_26

| | |
|------------------|--------------------|
| Name | MIO_PIN_26 |
| Relative Address | 0x00000768 |
| Absolute Address | 0xF8000768 |
| Width | 32 bits |
| Access Type | rw |
| Reset Value | 0x00001601 |
| Description | MIO Pin 26 Control |

Register MIO_PIN_26 Details

| Field Name | Bits | Type | Reset Value | Description |
|-------------|-------|------|-------------|--|
| reserved | 31:14 | rw | 0x0 | reserved |
| DisableRcvr | 13 | rw | 0x0 | Operates the same as MIO_PIN_00[DisableRcvr] |
| PULLUP | 12 | rw | 0x1 | Operates the same as MIO_PIN_00[PULLUP] |
| IO_Type | 11:9 | rw | 0x3 | Operates the same as MIO_PIN_00[IO_Type] |
| Speed | 8 | rw | 0x0 | Operates the same as MIO_PIN_00[Speed] |
| L3_SEL | 7:5 | rw | 0x0 | Level 3 Mux Select 000: GPIO 26 (bank 0), Input/Output 001: CAN 0 Rx, Input 010: I2C 0 Serial Clock, Input/Output 011: SWDT Clock, Input 100: SDIO 1 IO Bit 2, Input/Output 101: SPI 1 Slave Select 1, Output 110: reserved 111: UART 0 RxD, Input |
| L2_SEL | 4:3 | rw | 0x0 | Level 2 Mux Select 00: Level 3 Mux 01: SRAM/NOR Address Bit 11, Output 10: reserved 11: SDIO 0 Power Control, Output |
| L1_SEL | 2 | rw | 0x0 | Level 1 Mux Select 0: Level 2 Mux 1: Trace Port Data Bit 0, Output |
| L0_SEL | 1 | rw | 0x0 | Level 0 Mux Select 0: Level 1 Mux 1: Ethernet 0 RGMII RxD Bit 3, Input |
| TRI_ENABLE | 0 | rw | 0x1 | Operates the same as MIO_PIN_00[TRI_ENABLE] |

Register ([slcr](#)) MIO_PIN_27

| | |
|------------------|--------------------|
| Name | MIO_PIN_27 |
| Relative Address | 0x0000076C |
| Absolute Address | 0xF800076C |
| Width | 32 bits |
| Access Type | rw |
| Reset Value | 0x00001601 |
| Description | MIO Pin 27 Control |

Register MIO_PIN_27 Details

| Field Name | Bits | Type | Reset Value | Description |
|-------------|-------|------|-------------|---|
| reserved | 31:14 | rw | 0x0 | reserved |
| DisableRcvr | 13 | rw | 0x0 | Operates the same as MIO_PIN_00[DisableRcvr] |
| PULLUP | 12 | rw | 0x1 | Operates the same as MIO_PIN_00[PULLUP] |
| IO_Type | 11:9 | rw | 0x3 | Operates the same as MIO_PIN_00[IO_Type] |
| Speed | 8 | rw | 0x0 | Operates the same as MIO_PIN_00[Speed] |
| L3_SEL | 7:5 | rw | 0x0 | Level 3 Mux Select 000: GPIO 27 (bank 0), Input/Output 001: CAN 0 Tx, Output 010: I2C 0 Serial Data, Input/Output 011: SWDT Reset, Output 100: SDIO 1 IO Bit 3, Input/Output 101: SPI 1 Slave Select 2, Output 110: reserved 111: UART 0 Tx, Output |
| L2_SEL | 4:3 | rw | 0x0 | Level 2 Mux Select 00: Level 3 Mux 01: SRAM/NOR Address Bit 12, Output 10: reserved 11: SDIO 1 Power Control, Output |
| L1_SEL | 2 | rw | 0x0 | Level 1 Mux Select 0: Level 2 Mux 1: Trace Port Data Bit 1, Output |
| L0_SEL | 1 | rw | 0x0 | Level 0 Mux Select 0: Level 1 Mux 1: Ethernet 0 RGMII Rx Control, Input |
| TRI_ENABLE | 0 | rw | 0x1 | Operates the same as MIO_PIN_00[TRI_ENABLE] |

Register ([slcr](#)) MIO_PIN_28

| | |
|------------------|--------------------|
| Name | MIO_PIN_28 |
| Relative Address | 0x00000770 |
| Absolute Address | 0xF8000770 |
| Width | 32 bits |
| Access Type | rw |
| Reset Value | 0x00001601 |
| Description | MIO Pin 28 Control |

Register MIO_PIN_28 Details

| Field Name | Bits | Type | Reset Value | Description |
|-------------|-------|------|-------------|--|
| reserved | 31:14 | rw | 0x0 | reserved |
| DisableRcvr | 13 | rw | 0x0 | Operates the same as MIO_PIN_00[DisableRcvr] |
| PULLUP | 12 | rw | 0x1 | Operates the same as MIO_PIN_00[PULLUP] |
| IO_Type | 11:9 | rw | 0x3 | Operates the same as MIO_PIN_00[IO_Type] |
| Speed | 8 | rw | 0x0 | Operates the same as MIO_PIN_00[Speed] |
| L3_SEL | 7:5 | rw | 0x0 | Level 3 Mux Select 000: GPIO 28 (bank 0), Input/Output 001: CAN 1 Tx, Output 010: I2C 1 Serial Clock, Input/Output 011: reserved 100: SDIO 0 Clock, Input/Output 101: SPI 0 Serial Clock, Input/Output 110: TTC 1 Wave, Output 111: UART 1 TxD, Output |
| L2_SEL | 4:3 | rw | 0x0 | Level 2 Mux Select 00: Level 3 Mux 01: SRAM/NOR Address Bit 13, Output 10: reserved 11: SDIO 0 Power Control, Output |
| L1_SEL | 2 | rw | 0x0 | Level 1 Mux Select 0: Level 2 Mux 1: USB 0 ULPI Data Bit 4, Input/Output |
| L0_SEL | 1 | rw | 0x0 | Level 0 Mux Select 0: Level 1 Mux 1: Ethernet 1 RGMII Tx Clock, Output |
| TRI_ENABLE | 0 | rw | 0x1 | Operates the same as MIO_PIN_00[TRI_ENABLE] |

Register ([slcr](#)) MIO_PIN_29

| | |
|------------------|--------------------|
| Name | MIO_PIN_29 |
| Relative Address | 0x00000774 |
| Absolute Address | 0xF8000774 |
| Width | 32 bits |
| Access Type | rw |
| Reset Value | 0x00001601 |
| Description | MIO Pin 29 Control |

Register MIO_PIN_29 Details

| Field Name | Bits | Type | Reset Value | Description |
|-------------|-------|------|-------------|--|
| reserved | 31:14 | rw | 0x0 | reserved |
| DisableRcvr | 13 | rw | 0x0 | Operates the same as MIO_PIN_00[DisableRcvr] |
| PULLUP | 12 | rw | 0x1 | Operates the same as MIO_PIN_00[PULLUP] |
| IO_Type | 11:9 | rw | 0x3 | Operates the same as MIO_PIN_00[IO_Type] |
| Speed | 8 | rw | 0x0 | Operates the same as MIO_PIN_00[Speed] |
| L3_SEL | 7:5 | rw | 0x0 | Level 3 Mux Select 000: GPIO 29 (bank 0), Input/Output 001: CAN 1 Rx, Input 010: I2C 1 Serial Data, Input/Output 011: reserved 100: SDIO 0 Command, Input/Output 101: SPI 0 MISO, Input/Output 110: TTC 1 Clock, Input 111: UART 1 Rx, Input |
| L2_SEL | 4:3 | rw | 0x0 | Level 2 Mux Select 00: Level 3 Mux 01: SRAM/NOR Address Bit 14, Output 10: reserved 11: SDIO 1 Power Control, Output |
| L1_SEL | 2 | rw | 0x0 | Level 1 Mux Select 0: Level 2 Mux 1: USB 0 ULPI Direction, Input |
| L0_SEL | 1 | rw | 0x0 | Level 0 Mux Select 0: Level 1 Mux 1: Ethernet 1 RGMII Tx, Output |
| TRI_ENABLE | 0 | rw | 0x1 | Operates the same as MIO_PIN_00[TRI_ENABLE] |

Register ([slcr](#)) MIO_PIN_30

| | |
|------------------|--------------------|
| Name | MIO_PIN_30 |
| Relative Address | 0x00000778 |
| Absolute Address | 0xF8000778 |
| Width | 32 bits |
| Access Type | rw |
| Reset Value | 0x00001601 |
| Description | MIO Pin 30 Control |

Register MIO_PIN_30 Details

| Field Name | Bits | Type | Reset Value | Description |
|-------------|-------|------|-------------|---|
| reserved | 31:14 | rw | 0x0 | reserved |
| DisableRcvr | 13 | rw | 0x0 | Operates the same as MIO_PIN_00[DisableRcvr] |
| PULLUP | 12 | rw | 0x1 | Operates the same as MIO_PIN_00[PULLUP] |
| IO_Type | 11:9 | rw | 0x3 | Operates the same as MIO_PIN_00[IO_Type] |
| Speed | 8 | rw | 0x0 | Operates the same as MIO_PIN_00[Speed] |
| L3_SEL | 7:5 | rw | 0x0 | Level 3 Mux Select 000: GPIO 30 (bank 0), Input/Output 001: CAN 0 Rx, Input 010: I2C 0 Serial Clock, Input/Output 011: reserved 100: SDIO 0 IO Bit 0, Input/Output 101: SPI 0 Slave Select 0, Input/Output 110: TTC 0 Wave, Output 111: UART 0 RxD, Input |
| L2_SEL | 4:3 | rw | 0x0 | Level 2 Mux Select 00: Level 3 Mux 01: SRAM/NOR Address Bit 15, Output 10: reserved 11: SDIO 0 Power Control, Output |
| L1_SEL | 2 | rw | 0x0 | Level 1 Mux Select 0: Level 2 Mux 1: USB 0 ULPI Stop, Output |
| L0_SEL | 1 | rw | 0x0 | Level 0 Mux Select 0: Level 1 Mux 1: Ethernet 1 RGMII TxD Bit 1, Output |
| TRI_ENABLE | 0 | rw | 0x1 | Operates the same as MIO_PIN_00[TRI_ENABLE] |

Register ([slcr](#)) MIO_PIN_31

| | |
|------------------|--------------------|
| Name | MIO_PIN_31 |
| Relative Address | 0x0000077C |
| Absolute Address | 0xF800077C |
| Width | 32 bits |
| Access Type | rw |
| Reset Value | 0x00001601 |
| Description | MIO Pin 31 Control |

Register MIO_PIN_31 Details

| Field Name | Bits | Type | Reset Value | Description |
|-------------|-------|------|-------------|--|
| reserved | 31:14 | rw | 0x0 | reserved |
| DisableRcvr | 13 | rw | 0x0 | Operates the same as MIO_PIN_00[DisableRcvr] |
| PULLUP | 12 | rw | 0x1 | Operates the same as MIO_PIN_00[PULLUP] |
| IO_Type | 11:9 | rw | 0x3 | Operates the same as MIO_PIN_00[IO_Type] |
| Speed | 8 | rw | 0x0 | Operates the same as MIO_PIN_00[Speed] |
| L3_SEL | 7:5 | rw | 0x0 | Level 3 Mux Select 000: GPIO 31 (bank 0), Input/Output 001: CAN 0 Tx, Output 010: I2C 0 Serial Data, Input/Output 011: reserved 100: SDIO 0 IO Bit 1, Input/Output 101: SPI 0 Slave Select 1, Output 110: TTC 0 Clock, Input 111: UART 0 TxD, Output |
| L2_SEL | 4:3 | rw | 0x0 | Level 2 Mux Select 00: Level 3 Mux 01: SRAM/NOR Address Bit 16, Output 10: reserved 11: SDIO 1 Power Control, Output |
| L1_SEL | 2 | rw | 0x0 | Level 1 Mux Select 0: Level 2 Mux 1: USB 0 ULPI Next, Input |
| L0_SEL | 1 | rw | 0x0 | Level 0 Mux Select 0: Level 1 Mux 1: Ethernet 1 RGMII TxD Bit 2, Output |
| TRI_ENABLE | 0 | rw | 0x1 | Operates the same as MIO_PIN_00[TRI_ENABLE] |

Register ([slcr](#)) MIO_PIN_32

| | |
|------------------|--------------------|
| Name | MIO_PIN_32 |
| Relative Address | 0x00000780 |
| Absolute Address | 0xF8000780 |
| Width | 32 bits |
| Access Type | rw |
| Reset Value | 0x00001601 |
| Description | MIO Pin 32 Control |

Register MIO_PIN_32 Details

| Field Name | Bits | Type | Reset Value | Description |
|-------------|-------|------|-------------|--|
| reserved | 31:14 | rw | 0x0 | reserved |
| DisableRcvr | 13 | rw | 0x0 | Operates the same as MIO_PIN_00[DisableRcvr] |
| PULLUP | 12 | rw | 0x1 | Operates the same as MIO_PIN_00[PULLUP] |
| IO_Type | 11:9 | rw | 0x3 | Operates the same as MIO_PIN_00[IO_Type] |
| Speed | 8 | rw | 0x0 | Operates the same as MIO_PIN_00[Speed] |
| L3_SEL | 7:5 | rw | 0x0 | Level 3 Mux Select 000: GPIO 32 (bank 1), Input/Output 001: CAN 1 Tx, Output 010: I2C 1 Serial Clock, Input/Output 011: reserved 100: SDIO 0 IO Bit 2, Input/Output 101: SPI 0 Slave Select 2, Output 110: reserved 111: UART 1 Tx/D, Output |
| L2_SEL | 4:3 | rw | 0x0 | Level 2 Mux Select 00: Level 3 Mux 01: SRAM/NOR Address Bit 17, Output 10: reserved 11: SDIO 0 Power Control, Output |
| L1_SEL | 2 | rw | 0x0 | Level 1 Mux Select 0: Level 2 Mux 1: USB 0 ULPI Data Bit 0, Input/Output |
| L0_SEL | 1 | rw | 0x0 | Level 0 Mux Select 0: Level 1 Mux 1: Ethernet 1 RGMII Tx/D Bit 3, Output |
| TRI_ENABLE | 0 | rw | 0x1 | Operates the same as MIO_PIN_00[TRI_ENABLE] |

Register ([slcr](#)) MIO_PIN_33

| | |
|------------------|--------------------|
| Name | MIO_PIN_33 |
| Relative Address | 0x00000784 |
| Absolute Address | 0xF8000784 |
| Width | 32 bits |
| Access Type | rw |
| Reset Value | 0x00001601 |
| Description | MIO Pin 33 Control |

Register MIO_PIN_33 Details

| Field Name | Bits | Type | Reset Value | Description |
|-------------|-------|------|-------------|---|
| reserved | 31:14 | rw | 0x0 | reserved |
| DisableRcvr | 13 | rw | 0x0 | Operates the same as MIO_PIN_00[DisableRcvr] |
| PULLUP | 12 | rw | 0x1 | Operates the same as MIO_PIN_00[PULLUP] |
| IO_Type | 11:9 | rw | 0x3 | Operates the same as MIO_PIN_00[IO_Type] |
| Speed | 8 | rw | 0x0 | Operates the same as MIO_PIN_00[Speed] |
| L3_SEL | 7:5 | rw | 0x0 | Level 3 Mux Select 000: GPIO 33 (Bank 1), Input/Output 001: CAN 1 Rx, Input 010: I2C 1 Serial Data, Input/Output 011: reserved 100: SDIO 0 IO Bit 3, Input/Output 101: SPI 0 MOSI, Input/Output 110: reserved 111: UART 1 Rx/D, Input |
| L2_SEL | 4:3 | rw | 0x0 | Level 2 Mux Select 00: Level 3 Mux 01: SRAM/NOR Address Bit 18, Output 10: reserved 11: SDIO 1 Power Control, Output |
| L1_SEL | 2 | rw | 0x0 | Level 1 Mux Select 0: Level 2 Mux 1: USB 0 ULPI Data Bit 1, Input/Output |
| L0_SEL | 1 | rw | 0x0 | Level 0 Mux Select 0: Level 1 Mux 1: Ethernet 1 RGMII Tx Control, Output |
| TRI_ENABLE | 0 | rw | 0x1 | Operates the same as MIO_PIN_00[TRI_ENABLE] |

Register ([slcr](#)) MIO_PIN_34

| | |
|------------------|--------------------|
| Name | MIO_PIN_34 |
| Relative Address | 0x00000788 |
| Absolute Address | 0xF8000788 |
| Width | 32 bits |
| Access Type | rw |
| Reset Value | 0x00001601 |
| Description | MIO Pin 34 Control |

Register MIO_PIN_34 Details

| Field Name | Bits | Type | Reset Value | Description |
|-------------|-------|------|-------------|---|
| reserved | 31:14 | rw | 0x0 | reserved |
| DisableRcvr | 13 | rw | 0x0 | Operates the same as MIO_PIN_00[DisableRcvr] |
| PULLUP | 12 | rw | 0x1 | Operates the same as MIO_PIN_00[PULLUP] |
| IO_Type | 11:9 | rw | 0x3 | Operates the same as MIO_PIN_00[IO_Type] |
| Speed | 8 | rw | 0x0 | Operates the same as MIO_PIN_00[Speed] |
| L3_SEL | 7:5 | rw | 0x0 | Level 3 Mux Select 000: GPIO 34 (bank 1), Input/Output 001: CAN 0 Rx, Input 010: I2C 0 Serial Clock, Input/Output 011: PJTAG TDI, Input 100: SDIO 1 IO Bit 0, Input/Output 101: SPI 1 MOSI, Input/Output 110: reserved 111: UART 0 RxD, Input |
| L2_SEL | 4:3 | rw | 0x0 | Level 2 Mux Select 00: Level 3 Mux 01: SRAM/NOR Address Bit 19, Output 10: reserved 11: SDIO 0 Power Control, Output |
| L1_SEL | 2 | rw | 0x0 | Level 1 Mux Select 0: Level 2 Mux 1: USB 0 ULPI Data Bit 2, Input/Output |
| L0_SEL | 1 | rw | 0x0 | Level 0 Mux Select 0: Level 1 Mux 1: Ethernet 1 RGMII Rx Clock, Input |
| TRI_ENABLE | 0 | rw | 0x1 | Operates the same as MIO_PIN_00[TRI_ENABLE] |

Register ([slcr](#)) MIO_PIN_35

| | |
|------------------|--------------------|
| Name | MIO_PIN_35 |
| Relative Address | 0x0000078C |
| Absolute Address | 0xF800078C |
| Width | 32 bits |
| Access Type | rw |
| Reset Value | 0x00001601 |
| Description | MIO Pin 35 Control |

Register MIO_PIN_35 Details

| Field Name | Bits | Type | Reset Value | Description |
|-------------|-------|------|-------------|---|
| reserved | 31:14 | rw | 0x0 | reserved |
| DisableRcvr | 13 | rw | 0x0 | Operates the same as MIO_PIN_00[DisableRcvr] |
| PULLUP | 12 | rw | 0x1 | Operates the same as MIO_PIN_00[PULLUP] |
| IO_Type | 11:9 | rw | 0x3 | Operates the same as MIO_PIN_00[IO_Type] |
| Speed | 8 | rw | 0x0 | Operates the same as MIO_PIN_00[Speed] |
| L3_SEL | 7:5 | rw | 0x0 | Level 3 Mux Select 000: GPIO 35 (bank 1), Input/Output 001: CAN 0 Tx, Output 010: I2C 0 Serial Data, Input/Output 011: PJTAG TDO, Output 100: SDIO 1 Command, Input/Output 101: SPI 1 MISO, Input/Output 110: reserved 111: UART 0 Tx/D, Output |
| L2_SEL | 4:3 | rw | 0x0 | Level 2 Mux Select 00: Level 3 Mux 01: SRAM/NOR Address Bit 20, Output 10: reserved 11: SDIO 1 Power Control, Output |
| L1_SEL | 2 | rw | 0x0 | Level 1 Mux Select 0: Level 2 Mux 1: USB 0 ULPI Data Bit 3, Input/Output |
| L0_SEL | 1 | rw | 0x0 | Level 0 Mux Select 0: Level 1 Mux 1: Ethernet 1 RGMII Rx/D data Bit 0, Input |
| TRI_ENABLE | 0 | rw | 0x1 | Operates the same as MIO_PIN_00[TRI_ENABLE] |

Register ([slcr](#)) MIO_PIN_36

| | |
|------------------|--------------------|
| Name | MIO_PIN_36 |
| Relative Address | 0x00000790 |
| Absolute Address | 0xF8000790 |
| Width | 32 bits |
| Access Type | rw |
| Reset Value | 0x00001601 |
| Description | MIO Pin 36 Control |

Register MIO_PIN_36 Details

| Field Name | Bits | Type | Reset Value | Description |
|-------------|-------|------|-------------|--|
| reserved | 31:14 | rw | 0x0 | reserved |
| DisableRcvr | 13 | rw | 0x0 | Operates the same as MIO_PIN_00[DisableRcvr] |
| PULLUP | 12 | rw | 0x1 | Operates the same as MIO_PIN_00[PULLUP] |
| IO_Type | 11:9 | rw | 0x3 | Operates the same as MIO_PIN_00[IO_Type] |
| Speed | 8 | rw | 0x0 | Operates the same as MIO_PIN_00[Speed] |
| L3_SEL | 7:5 | rw | 0x0 | Level 3 Mux Select 000: GPIO 36 (bank 1), Input/Output 001: CAN 1 Tx, Output 010: I2C 1 Serial Clock, Input/Output 011: PJTAG TCK, Input 100: SDIO 1 Clock, Input/Output 101: SPI 1 Clock, Input/Output 110: reserved 111: UART 1 Tx/D, Output |
| L2_SEL | 4:3 | rw | 0x0 | Level 2 Mux Select 00: Level 3 Mux 01: SRAM/NOR Address Bit 21, Output 10: reserved 11: SDIO 0 Power Control, Output |
| L1_SEL | 2 | rw | 0x0 | Level 1 Mux Select 0: Level 2 Mux 1: USB 0 ULPI Clock, Input/Output |
| L0_SEL | 1 | rw | 0x0 | Level 0 Mux Select 0: Level 1 Mux 1: Ethernet 1 RGMII Data Bit 1 |
| TRI_ENABLE | 0 | rw | 0x1 | Operates the same as MIO_PIN_00[TRI_ENABLE] |

Register ([slcr](#)) MIO_PIN_37

| | |
|------------------|--------------------|
| Name | MIO_PIN_37 |
| Relative Address | 0x00000794 |
| Absolute Address | 0xF8000794 |
| Width | 32 bits |
| Access Type | rw |
| Reset Value | 0x00001601 |
| Description | MIO Pin 37 Control |

Register MIO_PIN_37 Details

| Field Name | Bits | Type | Reset Value | Description |
|-------------|-------|------|-------------|---|
| reserved | 31:14 | rw | 0x0 | reserved |
| DisableRcvr | 13 | rw | 0x0 | Operates the same as MIO_PIN_00[DisableRcvr] |
| PULLUP | 12 | rw | 0x1 | Operates the same as MIO_PIN_00[PULLUP] |
| IO_Type | 11:9 | rw | 0x3 | Operates the same as MIO_PIN_00[IO_Type] |
| Speed | 8 | rw | 0x0 | Operates the same as MIO_PIN_00[Speed] |
| L3_SEL | 7:5 | rw | 0x0 | Level 3 Mux Select 000: GPIO 37 (bank 1), Input/Output 001: CAN 1 Rx, Input 010: I2C 1 Serial Data, Input/Output 011: PJTAG TMS, Input 100: SDIO 1 IO Bit 1, Input/Output 101: SPI 1 Slave Select 0, Input/Output 110: reserved 111: UART 1 Rx/D, Input |
| L2_SEL | 4:3 | rw | 0x0 | Level 2 Mux Select 00: Level 3 Mux 01: SRAM/NOR Address Bit 22, Output 10: reserved 11: SDIO 1 Power Control, Output |
| L1_SEL | 2 | rw | 0x0 | Level 1 Mux Select 0: Level 2 Mux 1: USB 0 ULPI Data Bit 5, Input/Output |
| L0_SEL | 1 | rw | 0x0 | Level 0 Mux Select 0: Level 1 Mux 1: Ethernet 1 RGMII Rx/D Data Bit 2, Input |
| TRI_ENABLE | 0 | rw | 0x1 | Operates the same as MIO_PIN_00[TRI_ENABLE] |

Register ([slcr](#)) MIO_PIN_38

| | |
|------------------|--------------------|
| Name | MIO_PIN_38 |
| Relative Address | 0x00000798 |
| Absolute Address | 0xF8000798 |
| Width | 32 bits |
| Access Type | rw |
| Reset Value | 0x00001601 |
| Description | MIO Pin 38 Control |

Register MIO_PIN_38 Details

| Field Name | Bits | Type | Reset Value | Description |
|-------------|-------|------|-------------|---|
| reserved | 31:14 | rw | 0x0 | reserved |
| DisableRcvr | 13 | rw | 0x0 | Operates the same as MIO_PIN_00[DisableRcvr] |
| PULLUP | 12 | rw | 0x1 | Operates the same as MIO_PIN_00[PULLUP] |
| IO_Type | 11:9 | rw | 0x3 | Operates the same as MIO_PIN_00[IO_Type] |
| Speed | 8 | rw | 0x0 | Operates the same as MIO_PIN_00[Speed] |
| L3_SEL | 7:5 | rw | 0x0 | Level 3 Mux Select 000: GPIO 38 (bank 1), Input/Output 001: CAN 0 Rx, Input 010: I2C 0 Serial Clock, Input/Output 011: SWDT Clock, Input 100: SDIO 1 IO Bit 2, Input/Output 101: SPI 1 Slave Select 1, Output 110: reserved 111: UART 0 Rx, Input |
| L2_SEL | 4:3 | rw | 0x0 | Level 2 Mux Select 00: Level 3 Mux 01: SRAM/NOR Address Bit 23, Output 10: reserved 11: SDIO 0 Power Control, Output |
| L1_SEL | 2 | rw | 0x0 | Level 1 Mux Select 0: Level 2 Mux 1: USB 0 ULPI Data Bit 6, Input/Output |
| L0_SEL | 1 | rw | 0x0 | Level 0 Mux Select 0: Level 1 Mux 1: Ethernet 1 RGMII Rx, Input |
| TRI_ENABLE | 0 | rw | 0x1 | Operates the same as MIO_PIN_00[TRI_ENABLE] |

Register ([slcr](#)) MIO_PIN_39

| | |
|------------------|--------------------|
| Name | MIO_PIN_39 |
| Relative Address | 0x0000079C |
| Absolute Address | 0xF800079C |
| Width | 32 bits |
| Access Type | rw |
| Reset Value | 0x00001601 |
| Description | MIO Pin 39 Control |

Register MIO_PIN_39 Details

| Field Name | Bits | Type | Reset Value | Description |
|-------------|-------|------|-------------|---|
| reserved | 31:14 | rw | 0x0 | reserved |
| DisableRcvr | 13 | rw | 0x0 | Operates the same as MIO_PIN_00[DisableRcvr] |
| PULLUP | 12 | rw | 0x1 | Operates the same as MIO_PIN_00[PULLUP] |
| IO_Type | 11:9 | rw | 0x3 | Operates the same as MIO_PIN_00[IO_Type] |
| Speed | 8 | rw | 0x0 | Operates the same as MIO_PIN_00[Speed] |
| L3_SEL | 7:5 | rw | 0x0 | Level 3 Mux Select 000: GPIO 39 (bank 1), Input/Output 001: CAN 0 Tx, Output 010: I2C 0 Serial Data, Input/Output 011: SWDT Reset, Output 100: SDIO 1 IO Bit 3, Input/Output 101: SPI 1 Slave Select 2, Output 110: reserved 111: UART 0 Tx, Output |
| L2_SEL | 4:3 | rw | 0x0 | Level 2 Mux Select 00: Level 3 Mux 01: SRAM/NOR Address Bit 24, Output 10: reserved 11: SDIO 1 Power Control, Output |
| L1_SEL | 2 | rw | 0x0 | Level 1 Mux Select 0: Level 2 Mux 1: USB 0 ULPI Data Bit 7, Input/Output |
| L0_SEL | 1 | rw | 0x0 | Level 0 Mux Select 0: Level 1 Mux 1: Ethernet 1 RGMII Rx Control, Input |
| TRI_ENABLE | 0 | rw | 0x1 | Operates the same as MIO_PIN_00[TRI_ENABLE] |

Register ([slcr](#)) MIO_PIN_40

| | |
|------------------|--------------------|
| Name | MIO_PIN_40 |
| Relative Address | 0x000007A0 |
| Absolute Address | 0xF80007A0 |
| Width | 32 bits |
| Access Type | rw |
| Reset Value | 0x00001601 |
| Description | MIO Pin 40 Control |

Register MIO_PIN_40 Details

| Field Name | Bits | Type | Reset Value | Description |
|-------------|-------|------|-------------|---|
| reserved | 31:14 | rw | 0x0 | reserved |
| DisableRcvr | 13 | rw | 0x0 | Operates the same as MIO_PIN_00[DisableRcvr] |
| PULLUP | 12 | rw | 0x1 | Operates the same as MIO_PIN_00[PULLUP] |
| IO_Type | 11:9 | rw | 0x3 | Operates the same as MIO_PIN_00[IO_Type] |
| Speed | 8 | rw | 0x0 | Operates the same as MIO_PIN_00[Speed] |
| L3_SEL | 7:5 | rw | 0x0 | Level 3 Mux Select 000: GPIO 40 (bank 1), Input/Output 001: CAN 1 Tx, Output 010: I2C 1 Serial Clock, Input/Output 011: reserved 100: SDIO 0 Clock, Input/Output 101: SPI 0 Serial Clock, Input/Output 110: TTC 1 Wave, Output 111: UART 1 Tx, Output |
| L2_SEL | 4:3 | rw | 0x0 | Level 2 Mux Select 00: Level 3 Mux 01: reserved 10: reserved 11: SDIO 0 Power Control, Output |
| L1_SEL | 2 | rw | 0x0 | Level 1 Mux Select 0: Level 2 Mux 1: USB 1 ULPI Data Bit 4, Input/Output |
| L0_SEL | 1 | rw | 0x0 | Level 0 Mux Select 0: Level 1 Mux 1: reserved |
| TRI_ENABLE | 0 | rw | 0x1 | Operates the same as MIO_PIN_00[TRI_ENABLE] |

Register ([slcr](#)) MIO_PIN_41

| | |
|------------------|--------------------|
| Name | MIO_PIN_41 |
| Relative Address | 0x000007A4 |
| Absolute Address | 0xF80007A4 |
| Width | 32 bits |
| Access Type | rw |
| Reset Value | 0x00001601 |
| Description | MIO Pin 41 Control |

Register MIO_PIN_41 Details

| Field Name | Bits | Type | Reset Value | Description |
|-------------|-------|------|-------------|--|
| reserved | 31:14 | rw | 0x0 | reserved |
| DisableRcvr | 13 | rw | 0x0 | Operates the same as MIO_PIN_00[DisableRcvr] |
| PULLUP | 12 | rw | 0x1 | Operates the same as MIO_PIN_00[PULLUP] |
| IO_Type | 11:9 | rw | 0x3 | Operates the same as MIO_PIN_00[IO_Type] |
| Speed | 8 | rw | 0x0 | Operates the same as MIO_PIN_00[Speed] |
| L3_SEL | 7:5 | rw | 0x0 | Level 3 Mux Select 000: GPIO 41 (bank 1), Input/Output 001: CAN 1 Rx, Input 010: I2C 1 Serial Data, Input/Output 011: reserved 100: SDIO 0 Command, Input/Output 101: SPI 0 MISO, Input/Output 110: TTC 1 Clock, Input 111: UART 1 Rx/D, Input |
| L2_SEL | 4:3 | rw | 0x0 | Level 2 Mux Select 00: Level 3 Mux 01: reserved 10: reserved 11: SDIO 1 Power Control, Output |
| L1_SEL | 2 | rw | 0x0 | Level 1 Mux Select 0: Level 2 Mux 1: USB 1 ULPI Direction, Input |
| L0_SEL | 1 | rw | 0x0 | Level 0 Mux Select 0: Level 1 Mux 1: reserved |
| TRI_ENABLE | 0 | rw | 0x1 | Operates the same as MIO_PIN_00[TRI_ENABLE] |

Register ([slcr](#)) MIO_PIN_42

| | |
|------------------|--------------------|
| Name | MIO_PIN_42 |
| Relative Address | 0x000007A8 |
| Absolute Address | 0xF80007A8 |
| Width | 32 bits |
| Access Type | rw |
| Reset Value | 0x00001601 |
| Description | MIO Pin 42 Control |

Register MIO_PIN_42 Details

| Field Name | Bits | Type | Reset Value | Description |
|-------------|-------|------|-------------|---|
| reserved | 31:14 | rw | 0x0 | reserved |
| DisableRcvr | 13 | rw | 0x0 | Operates the same as MIO_PIN_00[DisableRcvr] |
| PULLUP | 12 | rw | 0x1 | Operates the same as MIO_PIN_00[PULLUP] |
| IO_Type | 11:9 | rw | 0x3 | Operates the same as MIO_PIN_00[IO_Type] |
| Speed | 8 | rw | 0x0 | Operates the same as MIO_PIN_00[Speed] |
| L3_SEL | 7:5 | rw | 0x0 | Level 3 Mux Select 000: GPIO 42 (bank 1), Input/Output 001: CAN 0 Rx, Input 010: I2C 0 Serial Clock, Input/Output 011: reserved 100: SDIO 0 IO Bit 0, Input/Output 101: SPI 0 Slave Select 0, Input/Output 110: TTC 0 Wave, Output 111: UART 0 RxD, Input |
| L2_SEL | 4:3 | rw | 0x0 | Level 2 Mux Select 00: Level 3 Mux 01: reserved 10: reserved 11: SDIO 0 Power Control, Output |
| L1_SEL | 2 | rw | 0x0 | Level 1 Mux Select 0: Level 2 Mux 1: USB 1 ULPI Stop, Output |
| L0_SEL | 1 | rw | 0x0 | Level 0 Mux Select 0: Level 1 Mux 1= Not Used |
| TRI_ENABLE | 0 | rw | 0x1 | Operates the same as MIO_PIN_00[TRI_ENABLE] |

Register ([slcr](#)) MIO_PIN_43

| | |
|------------------|--------------------|
| Name | MIO_PIN_43 |
| Relative Address | 0x000007AC |
| Absolute Address | 0xF80007AC |
| Width | 32 bits |
| Access Type | rw |
| Reset Value | 0x00001601 |
| Description | MIO Pin 43 Control |

Register MIO_PIN_43 Details

| Field Name | Bits | Type | Reset Value | Description |
|-------------|-------|------|-------------|--|
| reserved | 31:14 | rw | 0x0 | reserved |
| DisableRcvr | 13 | rw | 0x0 | Operates the same as MIO_PIN_00[DisableRcvr] |
| PULLUP | 12 | rw | 0x1 | Operates the same as MIO_PIN_00[PULLUP] |
| IO_Type | 11:9 | rw | 0x3 | Operates the same as MIO_PIN_00[IO_Type] |
| Speed | 8 | rw | 0x0 | Operates the same as MIO_PIN_00[Speed] |
| L3_SEL | 7:5 | rw | 0x0 | Level 3 Mux Select 000: GPIO 43 (bank 1), Input/Output 001: CAN 0 Tx, Output 010: I2C 0 Serial Data, Input/Output 011: reserved 100: SDIO 0 IO Bit 1, Input/Output 101: SPI 0 Slave Select 1, Output 110: TTC 0 Clock, Input 111: UART 0 TxD, Output |
| L2_SEL | 4:3 | rw | 0x0 | Level 2 Mux Select 00: Level 3 Mux 01: reserved 10: reserved 11: SDIO 1 Power Control, Output |
| L1_SEL | 2 | rw | 0x0 | Level 1 Mux Select 0: Level 2 Mux 1: USB 1 ULPI Next, Input |
| L0_SEL | 1 | rw | 0x0 | Level 0 Mux Select 0: Level 1 Mux 1: reserved |
| TRI_ENABLE | 0 | rw | 0x1 | Operates the same as MIO_PIN_00[TRI_ENABLE] |

Register ([slcr](#)) MIO_PIN_44

| | |
|------------------|--------------------|
| Name | MIO_PIN_44 |
| Relative Address | 0x000007B0 |
| Absolute Address | 0xF80007B0 |
| Width | 32 bits |
| Access Type | rw |
| Reset Value | 0x00001601 |
| Description | MIO Pin 44 Control |

Register MIO_PIN_44 Details

| Field Name | Bits | Type | Reset Value | Description |
|-------------|-------|------|-------------|--|
| reserved | 31:14 | rw | 0x0 | reserved |
| DisableRcvr | 13 | rw | 0x0 | Operates the same as MIO_PIN_00[DisableRcvr] |
| PULLUP | 12 | rw | 0x1 | Operates the same as MIO_PIN_00[PULLUP] |
| IO_Type | 11:9 | rw | 0x3 | Operates the same as MIO_PIN_00[IO_Type] |
| Speed | 8 | rw | 0x0 | Operates the same as MIO_PIN_00[Speed] |
| L3_SEL | 7:5 | rw | 0x0 | Level 3 Mux Select 000: GPIO 44 (bank 1), Input/Output 001: CAN 1 Tx, Output 010: I2C 1 Serial Clock, Input/Output 011: reserved 100: SDIO 0 IO Bit 2, Input/Output 101: SPI 0 Slave Select 2, Output 110: reserved 111: UART 1 Tx/D, Output |
| L2_SEL | 4:3 | rw | 0x0 | Level 2 Mux Select 00: Level 3 Mux 01: reserved 10: reserved 11: SDIO 0 Power Control, Output |
| L1_SEL | 2 | rw | 0x0 | Level 1 Mux Select 0: Level 2 Mux 1: USB 1 ULPI Data Bit 0, Input/Output |
| L0_SEL | 1 | rw | 0x0 | Level 0 Mux Select 0: Level 1 Mux 1: reserved |
| TRI_ENABLE | 0 | rw | 0x1 | Operates the same as MIO_PIN_00[TRI_ENABLE] |

Register ([slcr](#)) MIO_PIN_45

| | |
|------------------|--------------------|
| Name | MIO_PIN_45 |
| Relative Address | 0x000007B4 |
| Absolute Address | 0xF80007B4 |
| Width | 32 bits |
| Access Type | rw |
| Reset Value | 0x00001601 |
| Description | MIO Pin 45 Control |

Register MIO_PIN_45 Details

| Field Name | Bits | Type | Reset Value | Description |
|-------------|-------|------|-------------|--|
| reserved | 31:14 | rw | 0x0 | reserved |
| DisableRcvr | 13 | rw | 0x0 | Operates the same as MIO_PIN_00[DisableRcvr] |
| PULLUP | 12 | rw | 0x1 | Operates the same as MIO_PIN_00[PULLUP] |
| IO_Type | 11:9 | rw | 0x3 | Operates the same as MIO_PIN_00[IO_Type] |
| Speed | 8 | rw | 0x0 | Operates the same as MIO_PIN_00[Speed] |
| L3_SEL | 7:5 | rw | 0x0 | Level 3 Mux Select 000: GPIO 45 (bank 1), Input/Output 001: CAN 1 Rx, Input 010: I2C 1 Serial Data, Input/Output 011: reserved 100: SDIO 0 IO Bit 3, Input/Output 101: SPI 0 MOSI, Input/Output 110: reserved 111: UART 1 RxD, Input |
| L2_SEL | 4:3 | rw | 0x0 | Level 2 Mux Select 00: Level 3 Mux 01: reserved 10: reserved 11: SDIO 1 Power Control, Output |
| L1_SEL | 2 | rw | 0x0 | Level 1 Mux Select 0: Level 2 Mux 1: USB 1 ULPI Data Bit 1, Input/Output |
| L0_SEL | 1 | rw | 0x0 | Level 0 Mux Select 0: Level 1 Mux 1: reserved |
| TRI_ENABLE | 0 | rw | 0x1 | Operates the same as MIO_PIN_00[TRI_ENABLE] |

Register ([slcr](#)) MIO_PIN_46

| | |
|------------------|--------------------|
| Name | MIO_PIN_46 |
| Relative Address | 0x000007B8 |
| Absolute Address | 0xF80007B8 |
| Width | 32 bits |
| Access Type | rw |
| Reset Value | 0x00001601 |
| Description | MIO Pin 46 Control |

Register MIO_PIN_46 Details

| Field Name | Bits | Type | Reset Value | Description |
|-------------|-------|------|-------------|---|
| reserved | 31:14 | rw | 0x0 | reserved |
| DisableRcvr | 13 | rw | 0x0 | Operates the same as MIO_PIN_00[DisableRcvr] |
| PULLUP | 12 | rw | 0x1 | Operates the same as MIO_PIN_00[PULLUP] |
| IO_Type | 11:9 | rw | 0x3 | Operates the same as MIO_PIN_00[IO_Type] |
| Speed | 8 | rw | 0x0 | Operates the same as MIO_PIN_00[Speed] |
| L3_SEL | 7:5 | rw | 0x0 | Level 3 Mux Select 000: GPIO 46 (bank 1), Input/Output 001: CAN 0 Rx, Input 010: I2C 0 Serial Clock, Input/Output 011: PJTAG TDI, Input 100: SDIO 1 IO Bit 0, Input/Output 101: SPI 1 MOSI, Input/Output 110: reserved 111: UART 0 RxD, Input |
| L2_SEL | 4:3 | rw | 0x0 | Level 2 Mux Select 00: Level 3 Mux 01: reserved 10: reserved 11: SDIO 0 Power Control, Output |
| L1_SEL | 2 | rw | 0x0 | Level 1 Mux Select 0: Level 2 Mux 1: USB 1 ULPI Data Bit 2, Input/Output |
| L0_SEL | 1 | rw | 0x0 | Level 0 Mux Select 0: Level 1 Mux 1: reserved |
| TRI_ENABLE | 0 | rw | 0x1 | Operates the same as MIO_PIN_00[TRI_ENABLE] |

Register ([slcr](#)) MIO_PIN_47

| | |
|------------------|--------------------|
| Name | MIO_PIN_47 |
| Relative Address | 0x000007BC |
| Absolute Address | 0xF80007BC |
| Width | 32 bits |
| Access Type | rw |
| Reset Value | 0x00001601 |
| Description | MIO Pin 47 Control |

Register MIO_PIN_47 Details

| Field Name | Bits | Type | Reset Value | Description |
|-------------|-------|------|-------------|--|
| reserved | 31:14 | rw | 0x0 | reserved |
| DisableRcvr | 13 | rw | 0x0 | Operates the same as MIO_PIN_00[DisableRcvr] |
| PULLUP | 12 | rw | 0x1 | Operates the same as MIO_PIN_00[PULLUP] |
| IO_Type | 11:9 | rw | 0x3 | Operates the same as MIO_PIN_00[IO_Type] |
| Speed | 8 | rw | 0x0 | Operates the same as MIO_PIN_00[Speed] |
| L3_SEL | 7:5 | rw | 0x0 | Level 3 Mux Select 000: GPIO 47 (bank 1), Input/Output 001: CAN 0 Tx, Output 010: I2C 0 Serial Data, Input/Output 011: PJTAG TDO, Output 100: SDIO 1 Command, Input/Output 101: SPI 1 MISO, Input/Output 110: reserved 111: UART 0 TxD, Output |
| L2_SEL | 4:3 | rw | 0x0 | Level 2 Mux Select 00: Level 3 Mux 01: reserved 10: reserved 11: SDIO 1 Power Control, Output |
| L1_SEL | 2 | rw | 0x0 | Level 1 Mux Select 0: Level 2 Mux 1: USB 1 ULPI Data Bit 3, Input/Output |
| L0_SEL | 1 | rw | 0x0 | Level 0 Mux Select 0: Level 1 Mux 1: reserved |
| TRI_ENABLE | 0 | rw | 0x1 | Operates the same as MIO_PIN_00[TRI_ENABLE] |

Register ([slcr](#)) MIO_PIN_48

| | |
|------------------|--------------------|
| Name | MIO_PIN_48 |
| Relative Address | 0x000007C0 |
| Absolute Address | 0xF80007C0 |
| Width | 32 bits |
| Access Type | rw |
| Reset Value | 0x00001601 |
| Description | MIO Pin 48 Control |

Register MIO_PIN_48 Details

| Field Name | Bits | Type | Reset Value | Description |
|-------------|-------|------|-------------|---|
| reserved | 31:14 | rw | 0x0 | reserved |
| DisableRcvr | 13 | rw | 0x0 | Operates the same as MIO_PIN_00[DisableRcvr] |
| PULLUP | 12 | rw | 0x1 | Operates the same as MIO_PIN_00[PULLUP] |
| IO_Type | 11:9 | rw | 0x3 | Operates the same as MIO_PIN_00[IO_Type] |
| Speed | 8 | rw | 0x0 | Operates the same as MIO_PIN_00[Speed] |
| L3_SEL | 7:5 | rw | 0x0 | Level 3 Mux Select 000: GPIO 48 (bank 1), Input/Output 001: CAN 1 Tx, Output 010: I2C 1 Serial Clock, Input/Output 011: PJTAG TCK, Input 100: SDIO 1 Clock, Input/Output 101: SPI 1 Serial Clock, Input/Output 110: reserved 111: UART 1 Tx/D, Output |
| L2_SEL | 4:3 | rw | 0x0 | Level 2 Mux Select 00: Level 3 Mux 01: reserved 10: reserved 11: SDIO 0 Power Control, Output |
| L1_SEL | 2 | rw | 0x0 | Level 1 Mux Select 0: Level 2 Mux 1: USB 1 ULPI Clock, Input/Output |
| L0_SEL | 1 | rw | 0x0 | Level 0 Mux Select 0: Level 1 Mux 1: reserved |
| TRI_ENABLE | 0 | rw | 0x1 | Operates the same as MIO_PIN_00[TRI_ENABLE] |

Register ([slcr](#)) MIO_PIN_49

| | |
|------------------|--------------------|
| Name | MIO_PIN_49 |
| Relative Address | 0x000007C4 |
| Absolute Address | 0xF80007C4 |
| Width | 32 bits |
| Access Type | rw |
| Reset Value | 0x00001601 |
| Description | MIO Pin 49 Control |

Register MIO_PIN_49 Details

| Field Name | Bits | Type | Reset Value | Description |
|-------------|-------|------|-------------|--|
| reserved | 31:14 | rw | 0x0 | reserved |
| DisableRcvr | 13 | rw | 0x0 | Operates the same as MIO_PIN_00[DisableRcvr] |
| PULLUP | 12 | rw | 0x1 | Operates the same as MIO_PIN_00[PULLUP] |
| IO_Type | 11:9 | rw | 0x3 | Operates the same as MIO_PIN_00[IO_Type] |
| Speed | 8 | rw | 0x0 | Operates the same as MIO_PIN_00[Speed] |
| L3_SEL | 7:5 | rw | 0x0 | Level 3 Mux Select 000: GPIO 49 (bank 1), Input/Output 001: CAN 1 Rx, Input 010: I2C 1 Serial Data, Input/Output 011: PJTAG TMS, Input 100: SDIO 1 IO Bit 1, Input/Output 101: SPI 1 Select 0, Input/Output 110: reserved 111: UART 1 RxD, Input |
| L2_SEL | 4:3 | rw | 0x0 | Level 2 Mux Select 00: Level 3 Mux 01: reserved 10: reserved 11: SDIO 1 Power Control, Output |
| L1_SEL | 2 | rw | 0x0 | Level 1 Mux Select 0: Level 2 Mux 1: USB 1 ULPI Data Bit 5, Input/Output |
| L0_SEL | 1 | rw | 0x0 | Level 0 Mux Select 0: Level 1 Mux 1: reserved |
| TRI_ENABLE | 0 | rw | 0x1 | Operates the same as MIO_PIN_00[TRI_ENABLE] |

Register ([slcr](#)) MIO_PIN_50

| | |
|------------------|--------------------|
| Name | MIO_PIN_50 |
| Relative Address | 0x000007C8 |
| Absolute Address | 0xF80007C8 |
| Width | 32 bits |
| Access Type | rw |
| Reset Value | 0x00001601 |
| Description | MIO Pin 50 Control |

Register MIO_PIN_50 Details

| Field Name | Bits | Type | Reset Value | Description |
|-------------|-------|------|-------------|--|
| reserved | 31:14 | rw | 0x0 | reserved |
| DisableRcvr | 13 | rw | 0x0 | Operates the same as MIO_PIN_00[DisableRcvr] |
| PULLUP | 12 | rw | 0x1 | Operates the same as MIO_PIN_00[PULLUP] |
| IO_Type | 11:9 | rw | 0x3 | Operates the same as MIO_PIN_00[IO_Type] |
| Speed | 8 | rw | 0x0 | Operates the same as MIO_PIN_00[Speed] |
| L3_SEL | 7:5 | rw | 0x0 | Level 3 Mux Select 000: GPIO 50 (bank 1), Input/Output 001: CAN 0 Rx, Input 010: I2C 0 Serial Clock, Input/Output 011: SWDT Clock, Input 100: SDIO 1 IO Bit 2, Input/Output 101: SPI 1 Slave Select 1, Output 110: reserved 111: UART 0 RxD, Input |
| L2_SEL | 4:3 | rw | 0x0 | Level 2 Mux Select 00: Level 3 Mux 01: reserved 10: reserved 11: SDIO 0 Power Control, Output |
| L1_SEL | 2 | rw | 0x0 | Level 1 Mux Select 0: Level 2 Mux 1: USB 1 ULPI Data Bit 6, Input/Output |
| L0_SEL | 1 | rw | 0x0 | Level 0 Mux Select 0: Level 1 Mux 1: reserved |
| TRI_ENABLE | 0 | rw | 0x1 | Operates the same as MIO_PIN_00[TRI_ENABLE] |

Register ([slcr](#)) MIO_PIN_51

| | |
|------------------|--------------------|
| Name | MIO_PIN_51 |
| Relative Address | 0x000007CC |
| Absolute Address | 0xF80007CC |
| Width | 32 bits |
| Access Type | rw |
| Reset Value | 0x00001601 |
| Description | MIO Pin 51 Control |

Register MIO_PIN_51 Details

| Field Name | Bits | Type | Reset Value | Description |
|-------------|-------|------|-------------|--|
| reserved | 31:14 | rw | 0x0 | reserved |
| DisableRcvr | 13 | rw | 0x0 | Operates the same as MIO_PIN_00[DisableRcvr] |
| PULLUP | 12 | rw | 0x1 | Operates the same as MIO_PIN_00[PULLUP] |
| IO_Type | 11:9 | rw | 0x3 | Operates the same as MIO_PIN_00[IO_Type] |
| Speed | 8 | rw | 0x0 | Operates the same as MIO_PIN_00[Speed] |
| L3_SEL | 7:5 | rw | 0x0 | Level 3 Mux Select 000: GPIO 51 (bank 1), Input/Output 001: CAN 0 Tx, Output 010: I2C 0 Serial Data, Input/Output 011: SWDT Reset, Output 100: SDIO 1 IO Bit 3, Input/Output 101: SPI 1 Slave Select 2, Output 110: reserved 111: UART 0 TxD, Output |
| L2_SEL | 4:3 | rw | 0x0 | Level 2 Mux Select 00: Level 3 Mux 01: reserved 10: reserved 11: SDIO 1 Power Control, Output |
| L1_SEL | 2 | rw | 0x0 | Level 1 Mux Select 0: Level 2 Mux 1: USB 1 ULPI Data Bit 7, Input/Output |
| L0_SEL | 1 | rw | 0x0 | Level 0 Mux Select 0: Level 1 Mux 1: reserved |
| TRI_ENABLE | 0 | rw | 0x1 | Operates the same as MIO_PIN_00[TRI_ENABLE] |

Register ([slcr](#)) MIO_PIN_52

| | |
|------------------|--------------------|
| Name | MIO_PIN_52 |
| Relative Address | 0x000007D0 |
| Absolute Address | 0xF80007D0 |
| Width | 32 bits |
| Access Type | rw |
| Reset Value | 0x00001601 |
| Description | MIO Pin 52 Control |

Register MIO_PIN_52 Details

| Field Name | Bits | Type | Reset Value | Description |
|-------------|-------|------|-------------|--|
| reserved | 31:14 | rw | 0x0 | reserved |
| DisableRcvr | 13 | rw | 0x0 | Operates the same as MIO_PIN_00[DisableRcvr] |
| PULLUP | 12 | rw | 0x1 | Operates the same as MIO_PIN_00[PULLUP] |
| IO_Type | 11:9 | rw | 0x3 | Operates the same as MIO_PIN_00[IO_Type] |
| Speed | 8 | rw | 0x0 | Operates the same as MIO_PIN_00[Speed] |
| L3_SEL | 7:5 | rw | 0x0 | Level 3 Mux Select 000: GPIO 52 (bank 1), Input/Output 001: CAN 1 Tx, Output 010: I2C 1 Serial Clock, Input/Output 011: SWDT Clock, Input 100: MDIO 0 Clock, Output 101: MDIO 1 Clock, Output 110: reserved 111: UART 1 Tx/D, Output |
| L2_SEL | 4:3 | rw | 0x0 | Level 2 Mux Select 00: Level 3 Mux 01: reserved 10: reserved 11: SDIO 0 Power Control, Output |
| L1_SEL | 2 | rw | 0x0 | Level 1 Mux Select 0: Level 2 Mux 1: reserved |
| L0_SEL | 1 | rw | 0x0 | Level 0 Mux Select 0: Level 1 Mux 1: reserved |
| TRI_ENABLE | 0 | rw | 0x1 | Operates the same as MIO_PIN_00[TRI_ENABLE] |

Register ([slcr](#)) MIO_PIN_53

| | |
|------------------|--------------------|
| Name | MIO_PIN_53 |
| Relative Address | 0x000007D4 |
| Absolute Address | 0xF80007D4 |
| Width | 32 bits |
| Access Type | rw |
| Reset Value | 0x00001601 |
| Description | MIO Pin 53 Control |

Register MIO_PIN_53 Details

| Field Name | Bits | Type | Reset Value | Description |
|-------------|-------|------|-------------|--|
| reserved | 31:14 | rw | 0x0 | reserved |
| DisableRcvr | 13 | rw | 0x0 | Operates the same as MIO_PIN_00[DisableRcvr] |
| PULLUP | 12 | rw | 0x1 | Operates the same as MIO_PIN_00[PULLUP] |
| IO_Type | 11:9 | rw | 0x3 | Operates the same as MIO_PIN_00[IO_Type] |
| Speed | 8 | rw | 0x0 | Operates the same as MIO_PIN_00[Speed] |
| L3_SEL | 7:5 | rw | 0x0 | Level 3 Mux Select 000: GPIO 53 (bank 1), Input/Output 001: CAN 1 Rx, Input 010: I2C 1 Serial Data, Input/Output 011: SWDT Reset, Output 100: MDIO 0 Data, Input/Output 101: MDIO 1 Data, Input/Output 110: reserved 111: UART 1 Rx/D, Input |
| L2_SEL | 4:3 | rw | 0x0 | Level 2 Mux Select 00: Level 3 Mux 01: reserved 10: reserved 11: SDIO 1 Power Control, Output |
| L1_SEL | 2 | rw | 0x0 | Level 1 Mux Select 0: Level 2 Mux 1: reserved |
| L0_SEL | 1 | rw | 0x0 | Level 0 Mux Select 0: Level 1 Mux 1: reserved |
| TRI_ENABLE | 0 | rw | 0x1 | Operates the same as MIO_PIN_00[TRI_ENABLE] |

Register ([slcr](#)) MIO_LOOPBACK

| | |
|------------------|------------------------------|
| Name | MIO_LOOPBACK |
| Relative Address | 0x00000804 |
| Absolute Address | 0xF8000804 |
| Width | 32 bits |
| Access Type | rw |
| Reset Value | 0x00000000 |
| Description | Loopback function within MIO |

Register MIO_LOOPBACK Details

| Field Name | Bits | Type | Reset Value | Description |
|----------------|------|------|-------------|---|
| reserved | 31:4 | rw | 0x0 | reserved |
| I2C0_LOOP_I2C1 | 3 | rw | 0x0 | I2C Loopback Control. 0 = Connect I2C inputs according to MIO mapping. 1 = Loop I2C 0 outputs to I2C 1 inputs, and I2C 1 outputs to I2C 0 inputs. |
| CAN0_LOOP_CAN1 | 2 | rw | 0x0 | CAN Loopback Control. 0 = Connect CAN inputs according to MIO mapping. 1 = Loop CAN 0 Tx to CAN 1 Rx, and CAN 1 Tx to CAN 0 Rx. |
| UA0_LOOP_UA1 | 1 | rw | 0x0 | UART Loopback Control. 0 = Connect UART inputs according to MIO mapping. 1 = Loop UART 0 outputs to UART 1 inputs, and UART 1 outputs to UART 0 inputs. RXD/TXD cross-connected. RTS/CTS cross-connected. DSR, DTR, DCD and RI not used. |
| SPI0_LOOP_SPI1 | 0 | rw | 0x0 | SPI Loopback Control. 0 = Connect SPI inputs according to MIO mapping. 1 = Loop SPI 0 outputs to SPI 1 inputs, and SPI 1 outputs to SPI 0 inputs. The other SPI core will appear on the LS Slave Select. |

Register ([slcr](#)) MIO_MST_TRI0

| | |
|------------------|--------------|
| Name | MIO_MST_TRI0 |
| Relative Address | 0x0000080C |

| | |
|------------------|---------------------------------|
| Absolute Address | 0xF800080C |
| Width | 32 bits |
| Access Type | rw |
| Reset Value | 0xFFFFFFFF |
| Description | MIO pin Tri-state Enables, 31:0 |

Register MIO_MST_TRI0 Details

Parallel access to the master tri-state enables for MIO pins

| Field Name | Bits | Type | Reset Value | Description |
|------------|------|------|-------------|---|
| PIN_31_TRI | 31 | rw | 0x1 | Master Tri-state Enable for pin 31, active high |
| PIN_30_TRI | 30 | rw | 0x1 | Master Tri-state Enable for pin 30, active high |
| PIN_29_TRI | 29 | rw | 0x1 | Master Tri-state Enable for pin 29, active high |
| PIN_28_TRI | 28 | rw | 0x1 | Master Tri-state Enable for pin 28, active high |
| PIN_27_TRI | 27 | rw | 0x1 | Master Tri-state Enable for pin 27, active high |
| PIN_26_TRI | 26 | rw | 0x1 | Master Tri-state Enable for pin 26, active high |
| PIN_25_TRI | 25 | rw | 0x1 | Master Tri-state Enable for pin 25, active high |
| PIN_24_TRI | 24 | rw | 0x1 | Master Tri-state Enable for pin 24, active high |
| PIN_23_TRI | 23 | rw | 0x1 | Master Tri-state Enable for pin 23, active high |
| PIN_22_TRI | 22 | rw | 0x1 | Master Tri-state Enable for pin 22, active high |
| PIN_21_TRI | 21 | rw | 0x1 | Master Tri-state Enable for pin 21, active high |
| PIN_20_TRI | 20 | rw | 0x1 | Master Tri-state Enable for pin 20, active high |
| PIN_19_TRI | 19 | rw | 0x1 | Master Tri-state Enable for pin 19, active high |
| PIN_18_TRI | 18 | rw | 0x1 | Master Tri-state Enable for pin 18, active high |
| PIN_17_TRI | 17 | rw | 0x1 | Master Tri-state Enable for pin 17, active high |
| PIN_16_TRI | 16 | rw | 0x1 | Master Tri-state Enable for pin 16, active high |
| PIN_15_TRI | 15 | rw | 0x1 | Master Tri-state Enable for pin 15, active high |
| PIN_14_TRI | 14 | rw | 0x1 | Master Tri-state Enable for pin 14, active high |
| PIN_13_TRI | 13 | rw | 0x1 | Master Tri-state Enable for pin 13, active high |
| PIN_12_TRI | 12 | rw | 0x1 | Master Tri-state Enable for pin 12, active high |
| PIN_11_TRI | 11 | rw | 0x1 | Master Tri-state Enable for pin 11, active high |
| PIN_10_TRI | 10 | rw | 0x1 | Master Tri-state Enable for pin 10, active high |
| PIN_09_TRI | 9 | rw | 0x1 | Master Tri-state Enable for pin 9, active high |
| PIN_08_TRI | 8 | rw | 0x1 | Master Tri-state Enable for pin 8, active high |
| PIN_07_TRI | 7 | rw | 0x1 | Master Tri-state Enable for pin 7, active high |
| PIN_06_TRI | 6 | rw | 0x1 | Master Tri-state Enable for pin 6, active high |
| PIN_05_TRI | 5 | rw | 0x1 | Master Tri-state Enable for pin 5, active high |
| PIN_04_TRI | 4 | rw | 0x1 | Master Tri-state Enable for pin 4, active high |

| Field Name | Bits | Type | Reset Value | Description |
|------------|------|------|-------------|--|
| PIN_03_TRI | 3 | rw | 0x1 | Master Tri-state Enable for pin 3, active high |
| PIN_02_TRI | 2 | rw | 0x1 | Master Tri-state Enable for pin 2, active high |
| PIN_01_TRI | 1 | rw | 0x1 | Master Tri-state Enable for pin 1, active high |
| PIN_00_TRI | 0 | rw | 0x1 | Master Tri-state Enable for pin 0, active high |

Register ([slcr](#)) MIO_MST_TRI1

| | |
|------------------|----------------------------------|
| Name | MIO_MST_TRI1 |
| Relative Address | 0x00000810 |
| Absolute Address | 0xF8000810 |
| Width | 32 bits |
| Access Type | rw |
| Reset Value | 0x003FFFFFF |
| Description | MIO pin Tri-state Enables, 53:32 |

Register MIO_MST_TRI1 Details

Parallel access to the master tri-state enables for MIO pins

| Field Name | Bits | Type | Reset Value | Description |
|------------|-------|------|-------------|---|
| reserved | 31:22 | rw | 0x0 | reserved |
| PIN_53_TRI | 21 | rw | 0x1 | Master Tri-state Enable for pin 53, active high |
| PIN_52_TRI | 20 | rw | 0x1 | Master Tri-state Enable for pin 52, active high |
| PIN_51_TRI | 19 | rw | 0x1 | Master Tri-state Enable for pin 51, active high |
| PIN_50_TRI | 18 | rw | 0x1 | Master Tri-state Enable for pin 50, active high |
| PIN_49_TRI | 17 | rw | 0x1 | Master Tri-state Enable for pin 49, active high |
| PIN_48_TRI | 16 | rw | 0x1 | Master Tri-state Enable for pin 48, active high |
| PIN_47_TRI | 15 | rw | 0x1 | Master Tri-state Enable for pin 47, active high |
| PIN_46_TRI | 14 | rw | 0x1 | Master Tri-state Enable for pin 46, active high |
| PIN_45_TRI | 13 | rw | 0x1 | Master Tri-state Enable for pin 45, active high |
| PIN_44_TRI | 12 | rw | 0x1 | Master Tri-state Enable for pin 44, active high |
| PIN_43_TRI | 11 | rw | 0x1 | Master Tri-state Enable for pin 43, active high |
| PIN_42_TRI | 10 | rw | 0x1 | Master Tri-state Enable for pin 42, active high |
| PIN_41_TRI | 9 | rw | 0x1 | Master Tri-state Enable for pin 41, active high |
| PIN_40_TRI | 8 | rw | 0x1 | Master Tri-state Enable for pin 40, active high |
| PIN_39_TRI | 7 | rw | 0x1 | Master Tri-state Enable for pin 39, active high |
| PIN_38_TRI | 6 | rw | 0x1 | Master Tri-state Enable for pin 38, active high |
| PIN_37_TRI | 5 | rw | 0x1 | Master Tri-state Enable for pin 37, active high |

| Field Name | Bits | Type | Reset Value | Description |
|------------|------|------|-------------|---|
| PIN_36_TRI | 4 | rw | 0x1 | Master Tri-state Enable for pin 36, active high |
| PIN_35_TRI | 3 | rw | 0x1 | Master Tri-state Enable for pin 35, active high |
| PIN_34_TRI | 2 | rw | 0x1 | Master Tri-state Enable for pin 34, active high |
| PIN_33_TRI | 1 | rw | 0x1 | Master Tri-state Enable for pin 33, active high |
| PIN_32_TRI | 0 | rw | 0x1 | Master Tri-state Enable for pin 32, active high |

Register ([slcr](#)) SD0_WP_CD_SEL

| | |
|------------------|---------------------|
| Name | SD0_WP_CD_SEL |
| Relative Address | 0x00000830 |
| Absolute Address | 0xF8000830 |
| Width | 32 bits |
| Access Type | rw |
| Reset Value | 0x00000000 |
| Description | SDIO 0 WP CD select |

Register SD0_WP_CD_SEL Details

| Field Name | Bits | Type | Reset Value | Description |
|--------------|-------|------|-------------|---|
| reserved | 31:22 | rw | 0x0 | reserved |
| SDIO0_CD_SEL | 21:16 | rw | 0x0 | SDIO 0 CD Select. Values 53:0 select MIO input (any pin except bits 7 and 8) Values 63:54 select EMIO input |
| reserved | 15:6 | rw | 0x0 | reserved |
| SDIO0_WP_SEL | 5:0 | rw | 0x0 | SDIO 0 WP Select. Values 53:0 select MIO input (any pin except 7 and 8) Values 63:54 select EMIO input |

Register ([slcr](#)) SD1_WP_CD_SEL

| | |
|------------------|---------------------|
| Name | SD1_WP_CD_SEL |
| Relative Address | 0x00000834 |
| Absolute Address | 0xF8000834 |
| Width | 32 bits |
| Access Type | rw |
| Reset Value | 0x00000000 |
| Description | SDIO 1 WP CD select |

Register SD1_WP_CD_SEL Details

| Field Name | Bits | Type | Reset Value | Description |
|--------------|-------|------|-------------|---|
| reserved | 31:22 | rw | 0x0 | reserved |
| SDIO1_CD_SEL | 21:16 | rw | 0x0 | SDIO 1 CD Select. Values 53:0 select MIO input (any pin except bits 7 and 8) Values 63:54 select EMIO input |
| reserved | 15:6 | rw | 0x0 | reserved |
| SDIO1_WP_SEL | 5:0 | rw | 0x0 | SDIO 1 WP Select. Values 53:0 select MIO input (any pin except 7 and 8) Values 63:54 select EMIO input |

Register ([slcr](#)) LVL_SHFTR_EN

| | |
|------------------|-----------------------|
| Name | LVL_SHFTR_EN |
| Relative Address | 0x00000900 |
| Absolute Address | 0xF8000900 |
| Width | 32 bits |
| Access Type | rw |
| Reset Value | 0x00000000 |
| Description | Level Shifters Enable |

Register LVL_SHFTR_EN Details

| Field Name | Bits | Type | Reset Value | Description |
|-------------------|------|------|-------------|---|
| reserved | 31:5 | rw | 0x0 | Reserved. Writes are ignored, read data is zero. |
| reserved | 4 | rw | 0x0 | Reserved. Do not modify. |
| USER_LVL_SHFTR_EN | 3:0 | rw | 0x0 | Level shifter enable to drive signals between PS and PL. 0x0 = disable all level shifters 0xA = enable PS-to-PL level shifters 0xF = enable all level shifters All other = reserved |

Register ([slcr](#)) OCM_CFG

| | |
|------------------|------------|
| Name | OCM_CFG |
| Relative Address | 0x00000910 |
| Absolute Address | 0xF8000910 |

Width 32 bits
 Access Type rw
 Reset Value 0x00000000
 Description OCM Address Mapping

Register OCM_CFG Details

| Field Name | Bits | Type | Reset Value | Description |
|------------|------|------|-------------|---|
| reserved | 31:5 | rw | 0x0 | Reserved. Writes are ignored, read data is zero. |
| SWAP | 4 | rw | 0x0 | Always write the value that is read. |
| RAM_HI | 3:0 | rw | 0x0 | Maps the OCM RAM (in 64 KB sections) to the high or low address space: 0: low address. 1: high address. RAM_HI [0] is first 64 KB RAM_HI [1] is second 64 KB RAM_HI [2] is third 64 KB RAM_HI [3] is fourth 64 KB Refer to the OCM chapter for more details. |

Register ([slcr](#)) Reserved

Name Reserved
 Relative Address 0x00000A1C
 Absolute Address 0xF8000A1C
 Width 32 bits
 Access Type rw
 Reset Value 0x00010101
 Description Reserved

Register Reserved Details

| Field Name | Bits | Type | Reset Value | Description |
|------------|-------|------|-------------|--|
| reserved | 23:22 | rw | 0x0 | Reserved. Do not modify. |
| reserved | 21 | rw | 0x0 | Reserved. Do not modify. |
| reserved | 20:19 | rw | 0x0 | Reserved. Do not modify. |
| reserved | 18:16 | rw | 0x1 | Must be set to 2. Any other value including the reset value may lead to undefined behavior. |
| reserved | 15:14 | rw | 0x0 | Reserved. Do not modify. |
| reserved | 13 | rw | 0x0 | Reserved. Do not modify. |

| Field Name | Bits | Type | Reset Value | Description |
|------------|-------|------|-------------|--|
| reserved | 12:11 | rw | 0x0 | Reserved. Do not modify. |
| reserved | 10:8 | rw | 0x1 | Must be set to 2. Any other value including the reset value may lead to undefined behavior. |
| reserved | 7:6 | rw | 0x0 | Reserved. Do not modify. |
| reserved | 5 | rw | 0x0 | Reserved. Do not modify. |
| reserved | 4:3 | rw | 0x0 | Reserved. Do not modify. |
| reserved | 2:0 | rw | 0x1 | Must be set to 2. Any other value including the reset value may lead to undefined behavior. |

Register ([slcr](#)) GPIOB_CTRL

| | |
|------------------|----------------------|
| Name | GPIOB_CTRL |
| Relative Address | 0x00000B00 |
| Absolute Address | 0xF8000B00 |
| Width | 32 bits |
| Access Type | rw |
| Reset Value | 0x00000000 |
| Description | PS IO Buffer Control |

Register GPIOB_CTRL Details

| Field Name | Bits | Type | Reset Value | Description |
|------------|-------|------|-------------|--|
| reserved | 31:12 | rw | 0x0 | Reserved. Writes are ignored, read data is zero. |
| VREF_SW_EN | 11 | rw | 0x0 | Enables the VREF switch 0: internal 1: external |
| reserved | 10 | rw | 0x0 | Reserved. Do not modify. |
| reserved | 9 | rw | 0x0 | Reserved. Do not modify. |
| reserved | 8 | rw | 0x0 | Reserved. Do not modify. |
| reserved | 7 | rw | 0x0 | Reserved. Do not modify. |
| VREF_SEL | 6:4 | rw | 0x0 | Specifies GPIO VREF Selection 000: VREF = Disabled 001: VREF = 0.9V Other values reserved |
| reserved | 3 | rw | 0x0 | Reserved. Do not modify. |
| reserved | 2 | rw | 0x0 | Reserved. Do not modify. |

| Field Name | Bits | Type | Reset Value | Description |
|------------|------|------|-------------|---------------------------------|
| reserved | 1 | rw | 0x0 | Reserved. Do not modify. |
| VREF_EN | 0 | rw | 0x0 | Enables VREF internal generator |

Register ([slcr](#)) GPIOB_CFG_CMOS18

| | |
|------------------|----------------------------|
| Name | GPIOB_CFG_CMOS18 |
| Relative Address | 0x0000B04 |
| Absolute Address | 0xF800B04 |
| Width | 32 bits |
| Access Type | rw |
| Reset Value | 0x00000000 |
| Description | MIO GPIOB CMOS 1.8V config |

Register GPIOB_CFG_CMOS18 Details

The only allowed values for this register are 0x00000000 (reset value) and 0x0C301166 (normal operation)

| Field Name | Bits | Type | Reset Value | Description |
|------------|-------|------|-------------|--|
| reserved | 31:28 | rw | 0x0 | Reserved. Writes are ignored, read data is zero. |
| reserved | 27:25 | rw | 0x0 | Reserved. Do not modify. |
| reserved | 24:22 | rw | 0x0 | Reserved. Do not modify. |
| reserved | 21:19 | rw | 0x0 | Reserved. Do not modify. |
| reserved | 18:16 | rw | 0x0 | Reserved. Do not modify. |
| reserved | 15:12 | rw | 0x0 | Reserved. Do not modify. |
| reserved | 11:8 | rw | 0x0 | Reserved. Do not modify. |
| reserved | 7:4 | rw | 0x0 | Reserved. Do not modify. |
| reserved | 3:0 | rw | 0x0 | Reserved. Do not modify. |

Register ([slcr](#)) GPIOB_CFG_CMOS25

| | |
|------------------|----------------------------|
| Name | GPIOB_CFG_CMOS25 |
| Relative Address | 0x0000B08 |
| Absolute Address | 0xF800B08 |
| Width | 32 bits |
| Access Type | rw |
| Reset Value | 0x00000000 |
| Description | MIO GPIOB CMOS 2.5V config |

Register GPIOB_CFG_CMOS25 Details

The only allowed values for this register are 0x00000000 (reset value) and 0x0C301100 (normal operation)

| Field Name | Bits | Type | Reset Value | Description |
|------------|-------|------|-------------|--|
| reserved | 31:28 | rw | 0x0 | Reserved. Writes are ignored, read data is zero. |
| reserved | 27:25 | rw | 0x0 | Reserved. Do not modify. |
| reserved | 24:22 | rw | 0x0 | Reserved. Do not modify. |
| reserved | 21:19 | rw | 0x0 | Reserved. Do not modify. |
| reserved | 18:16 | rw | 0x0 | Reserved. Do not modify. |
| reserved | 15:12 | rw | 0x0 | Reserved. Do not modify. |
| reserved | 11:8 | rw | 0x0 | Reserved. Do not modify. |
| reserved | 7:4 | rw | 0x0 | Reserved. Do not modify. |
| reserved | 3:0 | rw | 0x0 | Reserved. Do not modify. |

Register ([slcr](#)) GPIOB_CFG_CMOS33

| | |
|------------------|----------------------------|
| Name | GPIOB_CFG_CMOS33 |
| Relative Address | 0x00000B0C |
| Absolute Address | 0xF8000B0C |
| Width | 32 bits |
| Access Type | rw |
| Reset Value | 0x00000000 |
| Description | MIO GPIOB CMOS 3.3V config |

Register GPIOB_CFG_CMOS33 Details

The only allowed values for this register are 0x00000000 (reset value) and 0x0C301166 (normal operation)

| Field Name | Bits | Type | Reset Value | Description |
|------------|-------|------|-------------|--|
| reserved | 31:28 | rw | 0x0 | Reserved. Writes are ignored, read data is zero. |
| reserved | 27:25 | rw | 0x0 | Reserved. Do not modify. |
| reserved | 24:22 | rw | 0x0 | Reserved. Do not modify. |
| reserved | 21:19 | rw | 0x0 | Reserved. Do not modify. |
| reserved | 18:16 | rw | 0x0 | Reserved. Do not modify. |
| reserved | 15:12 | rw | 0x0 | Reserved. Do not modify. |
| reserved | 11:8 | rw | 0x0 | Reserved. Do not modify. |

| Field Name | Bits | Type | Reset Value | Description |
|------------|------|------|-------------|--------------------------|
| reserved | 7:4 | rw | 0x0 | Reserved. Do not modify. |
| reserved | 3:0 | rw | 0x0 | Reserved. Do not modify. |

Register ([slcr](#)) GPIOB_CFG_HSTL

| | |
|------------------|-----------------------|
| Name | GPIOB_CFG_HSTL |
| Relative Address | 0x00000B14 |
| Absolute Address | 0xF8000B14 |
| Width | 32 bits |
| Access Type | rw |
| Reset Value | 0x00000000 |
| Description | MIO GPIOB HSTL config |

Register GPIOB_CFG_HSTL Details

The only allowed values for this register are 0x00000000 (reset value) and 0x0C750077 (normal operation).

You must provide a VREF or use the internal VREF generator.

When setting the input to HSTL, you must ensure that

VCCO_MIO is below 1.8V. If not, this will lead to long term damage to the IO.

| Field Name | Bits | Type | Reset Value | Description |
|------------|-------|------|-------------|--|
| reserved | 31:28 | rw | 0x0 | Reserved. Writes are ignored, read data is zero. |
| reserved | 27:25 | rw | 0x0 | Reserved. Do not modify. |
| reserved | 24:22 | rw | 0x0 | Reserved. Do not modify. |
| reserved | 21:19 | rw | 0x0 | Reserved. Do not modify. |
| reserved | 18:16 | rw | 0x0 | Reserved. Do not modify. |
| reserved | 15:12 | rw | 0x0 | Reserved. Do not modify. |
| reserved | 11:8 | rw | 0x0 | Reserved. Do not modify. |
| reserved | 7:4 | rw | 0x0 | Reserved. Do not modify. |
| reserved | 3:0 | rw | 0x0 | Reserved. Do not modify. |

Register ([slcr](#)) GPIOB_DRVR_BIAS_CTRL

| | |
|------------------|----------------------|
| Name | GPIOB_DRVR_BIAS_CTRL |
| Relative Address | 0x00000B18 |
| Absolute Address | 0xF8000B18 |

| | |
|-------------|-------------------------------|
| Width | 32 bits |
| Access Type | mixed |
| Reset Value | 0x00000000 |
| Description | MIO GPIOB Driver Bias Control |

Register GPIOB_DRVR_BIAS_CTRL Details

| Field Name | Bits | Type | Reset Value | Description |
|--------------|-------|------|-------------|---|
| RB_VCFG | 31 | ro | 0x0 | Right Bank (Bank 1 and Bank 501) VCFG (Read Only) |
| RB_DRVR_BIAS | 30:16 | rw | 0x0 | Right Bank driver bias control |
| LB_VCFG | 15 | ro | 0x0 | Left Bank (Bank 0 and Bank 500) VCFG (Read Only) |
| LB_DRVR_BIAS | 14:0 | rw | 0x0 | Left Bank driver bias control |

Register ([slcr](#)) DDRIOB_ADDR0

| | |
|------------------|--|
| Name | DDRIOB_ADDR0 |
| Relative Address | 0x00000B40 |
| Absolute Address | 0xF8000B40 |
| Width | 32 bits |
| Access Type | rw |
| Reset Value | 0x00000800 |
| Description | DDR IOB Config for A[14:0], CKE and DRST_B |

Register DDRIOB_ADDR0 Details

| Field Name | Bits | Type | Reset Value | Description |
|------------|-------|------|-------------|---|
| reserved | 31:12 | rw | 0x0 | Reserved |
| PULLUP_EN | 11 | rw | 0x1 | enables pullup on output 0: no pullup 1: pullup enabled |
| OUTPUT_EN | 10:9 | rw | 0x0 | Enables output mode to enable output ties to 00: ibuf 01 and 10: reserved 11: obuf |

| Field Name | Bits | Type | Reset Value | Description |
|-------------------|------|------|-------------|---|
| TERM_DISABLE_MODE | 8 | rw | 0x0 | Termination is used during read transactions and may be disabled (automatically by hardware) when there are no reads taking place through the DDR Interface. Disabling termination reduces power consumption. 0: termination always enabled 1: use 'dynamic_dci_ts' to disable termination when not in use NOTE: This bit must be 0 during DRAM init/training. It may be set to 1 after init/training completes. |
| IBUF_DISABLE_MODE | 7 | rw | 0x0 | Use ibuf_disable_into control ibuf 0: ibuf is enabled 1: use ibuf_disable_in_to control enable NOTE: This must be 0 during DRAM init/training and can only be set to 1 after init/training completes. |
| DCI_TYPE | 6:5 | rw | 0x0 | DCI Mode Selection: 00: DCI Disabled (DDR2/3L ADDR and CLOCK) 01: DCI Drive (LPDDR2) 10: reserved 11: DCI Termination (DDR2/3/3L DATA and DIFF) |
| TERM_EN | 4 | rw | 0x0 | Tri State Termination Enable: 0: disable 1: enable |
| DCI_UPDATE_B | 3 | rw | 0x0 | DCI Update Enable: 0: disable 1: enable |
| INP_TYPE | 2:1 | rw | 0x0 | Input buffer control: 00: Input off (input signal to selected controller is driven Low). 01: Vref based differential receiver for SSTL, HSTL. 10: Differential input receiver. 11: LVCMOS receiver. |
| reserved | 0 | rw | 0x0 | Reserved. Do not modify. |

Register ([slcr](#)) DDRIOB_ADDR1

| | |
|------------------|--------------|
| Name | DDRIOB_ADDR1 |
| Relative Address | 0x00000B44 |
| Absolute Address | 0xF8000B44 |
| Width | 32 bits |
| Access Type | rw |
| Reset Value | 0x00000800 |

Description DDR IOB Config for BA[2:0], ODT, CS_B, WE_B, RAS_B and CAS_B

Register DDRIOB_ADDR1 Details

| Field Name | Bits | Type | Reset Value | Description |
|-------------------|-------|------|-------------|---|
| reserved | 31:12 | rw | 0x0 | Reserved |
| PULLUP_EN | 11 | rw | 0x1 | enables pullup on output 0: no pullup 1: pullup enabled |
| OUTPUT_EN | 10:9 | rw | 0x0 | Enables output mode to enable output ties to 00: ibuf 01 and 10: reserved 11: obuf |
| TERM_DISABLE_MODE | 8 | rw | 0x0 | Termination is used during read transactions and may be disabled (automatically by hardware) when there are no reads taking place through the DDR Interface. Disabling termination reduces power consumption. 0: termination always enabled 1: use 'dynamic_dci_ts' to disable termination when not in use NOTE: This bit must be 0 during DRAM init/training. It may be set to 1 after init/training completes. |
| IBUF_DISABLE_MODE | 7 | rw | 0x0 | Use ibuf_disable_into control ibuf 0: ibuf is enabled 1: use ibuf_disable_in_to control enable NOTE: This must be 0 during DRAM init/training and can only be set to 1 after init/training completes. |
| DCI_TYPE | 6:5 | rw | 0x0 | DCI Mode Selection: 00: DCI Disabled (DDR2/3L ADDR and CLOCK) 01: DCI Drive (LPDDR2) 10: reserved 11: DCI Termination (DDR2/3/3L DATA and DIFF) |
| TERM_EN | 4 | rw | 0x0 | Tri State Termination Enable: 0: disable 1: enable |
| DCI_UPDATE_B | 3 | rw | 0x0 | DCI Update Enable: 0: disable 1: enable |

| Field Name | Bits | Type | Reset Value | Description |
|------------|------|------|-------------|---|
| INP_TYPE | 2:1 | rw | 0x0 | Input buffer control: 00: Input off (input signal to selected controller is driven Low). 01: Vref based differential receiver for SSTL, HSTL. 10: Differential input receiver. 11: LVCMOS receiver. |
| reserved | 0 | rw | 0x0 | Reserved. Do not modify. |

Register ([slcr](#)) DDRIOB_DATA0

| | |
|------------------|------------------------------|
| Name | DDRIOB_DATA0 |
| Relative Address | 0x00000B48 |
| Absolute Address | 0xF8000B48 |
| Width | 32 bits |
| Access Type | rw |
| Reset Value | 0x00000800 |
| Description | DDR IOB Config for Data 15:0 |

Register DDRIOB_DATA0 Details

| Field Name | Bits | Type | Reset Value | Description |
|-------------------|-------|------|-------------|---|
| reserved | 31:12 | rw | 0x0 | Reserved |
| PULLUP_EN | 11 | rw | 0x1 | enables pullup on output 0: no pullup 1: pullup enabled |
| OUTPUT_EN | 10:9 | rw | 0x0 | Enables output mode to enable output ties to 00: ibuf 01 and 10: reserved 11: obuf |
| TERM_DISABLE_MODE | 8 | rw | 0x0 | Termination is used during read transactions and may be disabled (automatically by hardware) when there are no reads taking place through the DDR Interface. Disabling termination reduces power consumption. 0: termination always enabled 1: use 'dynamic_dci_ts' to disable termination when not in use NOTE: This bit must be 0 during DRAM init/training. It may be set to 1 after init/training completes. |

| Field Name | Bits | Type | Reset Value | Description |
|-------------------|------|------|-------------|---|
| IBUF_DISABLE_MODE | 7 | rw | 0x0 | Use ibuf_disable_into control ibuf 0: ibuf is enabled 1: use ibuf_disable_in_to control enable NOTE: This must be 0 during DRAM init/training and can only be set to 1 after init/training completes. |
| DCI_TYPE | 6:5 | rw | 0x0 | DCI Mode Selection: 00: DCI Disabled (DDR2/3L ADDR and CLOCK) 01: DCI Drive (LPDDR2) 10: reserved 11: DCI Termination (DDR2/3/3L DATA and DIFF) |
| TERM_EN | 4 | rw | 0x0 | Tri State Termination Enable: 0: disable 1: enable |
| DCI_UPDATE_B | 3 | rw | 0x0 | DCI Update Enable: 0: disable 1: enable |
| INP_TYPE | 2:1 | rw | 0x0 | Input buffer control: 00: Input off (input signal to selected controller is driven Low). 01: Vref based differential receiver for SSTL, HSTL. 10: Differential input receiver. 11: LVCMOS receiver. |
| reserved | 0 | rw | 0x0 | Reserved. Do not modify. |

Register ([slcr](#)) DDRIOB_DATA1

| | |
|------------------|-------------------------------|
| Name | DDRIOB_DATA1 |
| Relative Address | 0x00000B4C |
| Absolute Address | 0xF8000B4C |
| Width | 32 bits |
| Access Type | rw |
| Reset Value | 0x00000800 |
| Description | DDR IOB Config for Data 31:16 |

Register DDRIOB_DATA1 Details

| Field Name | Bits | Type | Reset Value | Description |
|------------|-------|------|-------------|---|
| reserved | 31:12 | rw | 0x0 | Reserved |
| PULLUP_EN | 11 | rw | 0x1 | enables pullup on output 0: no pullup 1: pullup enabled |

| Field Name | Bits | Type | Reset Value | Description |
|-------------------|------|------|-------------|---|
| OUTPUT_EN | 10:9 | rw | 0x0 | Enables output mode to enable output ties to 00: ibuf 01 and 10: reserved 11: obuf |
| TERM_DISABLE_MODE | 8 | rw | 0x0 | Termination is used during read transactions and may be disabled (automatically by hardware) when there are no reads taking place through the DDR Interface. Disabling termination reduces power consumption. 0: termination always enabled 1: use 'dynamic_dci_ts' to disable termination when not in use NOTE: This bit must be 0 during DRAM init/training. It may be set to 1 after init/training completes. |
| IBUF_DISABLE_MODE | 7 | rw | 0x0 | Use ibuf_disable_into control ibuf 0: ibuf is enabled 1: use ibuf_disable_in_to control enable NOTE: This must be 0 during DRAM init/training and can only be set to 1 after init/training completes. |
| DCI_TYPE | 6:5 | rw | 0x0 | DCI Mode Selection: 00: DCI Disabled (DDR2/3L ADDR and CLOCK) 01: DCI Drive (LPDDR2) 10: reserved 11: DCI Termination (DDR2/3/3L DATA and DIFF) |
| TERM_EN | 4 | rw | 0x0 | Tri State Termination Enable: 0: disable 1: enable |
| DCI_UPDATE_B | 3 | rw | 0x0 | DCI Update Enable: 0: disable 1: enable |
| INP_TYPE | 2:1 | rw | 0x0 | Input buffer control: 00: Input off (input signal to selected controller is driven Low). 01: Vref based differential receiver for SSTL, HSTL. 10: Differential input receiver. 11: LVCMOS receiver. |
| reserved | 0 | rw | 0x0 | Reserved. Do not modify. |

Register ([slcr](#)) DDRIOB_DIFF0

Name DDRIOB_DIFF0
Relative Address 0x00000B50
Absolute Address 0xF8000B50

Width 32 bits
 Access Type rw
 Reset Value 0x00000800
 Description DDR IOB Config for DQS 1:0

Register DDRIOB_DIFF0 Details

| Field Name | Bits | Type | Reset Value | Description |
|-------------------|-------|------|-------------|---|
| reserved | 31:12 | rw | 0x0 | Reserved |
| PULLUP_EN | 11 | rw | 0x1 | enables pullup on output 0: no pullup 1: pullup enabled |
| OUTPUT_EN | 10:9 | rw | 0x0 | Enables output mode to enable output ties to 00: ibuf 01 and 10: reserved 11: obuf |
| TERM_DISABLE_MODE | 8 | rw | 0x0 | Termination is used during read transactions and may be disabled (automatically by hardware) when there are no reads taking place through the DDR Interface. Disabling termination reduces power consumption. 0: termination always enabled 1: use 'dynamic_dci_ts' to disable termination when not in use NOTE: This bit must be 0 during DRAM init/training. It may be set to 1 after init/training completes. |
| IBUF_DISABLE_MODE | 7 | rw | 0x0 | Use ibuf_disable_into control ibuf 0: ibuf is enabled 1: use ibuf_disable_in_to control enable NOTE: This must be 0 during DRAM init/training and can only be set to 1 after init/training completes. |
| DCI_TYPE | 6:5 | rw | 0x0 | DCI Mode Selection: 00: DCI Disabled (DDR2/3L ADDR and CLOCK) 01: DCI Drive (LPDDR2) 10: reserved 11: DCI Termination (DDR2/3/3L DATA and DIFF) |
| TERM_EN | 4 | rw | 0x0 | Tri State Termination Enable: 0: disable 1: enable |
| DCI_UPDATE_B | 3 | rw | 0x0 | DCI Update Enable: 0: disable 1: enable |

| Field Name | Bits | Type | Reset Value | Description |
|------------|------|------|-------------|---|
| INP_TYPE | 2:1 | rw | 0x0 | Input buffer control: 00: Input off (input signal to selected controller is driven Low). 01: Vref based differential receiver for SSTL, HSTL. 10: Differential input receiver. 11: LVCMOS receiver. |
| reserved | 0 | rw | 0x0 | Reserved. Do not modify. |

Register ([slcr](#)) DDRIOB_DIFF1

| | |
|------------------|----------------------------|
| Name | DDRIOB_DIFF1 |
| Relative Address | 0x00000B54 |
| Absolute Address | 0xF8000B54 |
| Width | 32 bits |
| Access Type | rw |
| Reset Value | 0x00000800 |
| Description | DDR IOB Config for DQS 3:2 |

Register DDRIOB_DIFF1 Details

| Field Name | Bits | Type | Reset Value | Description |
|-------------------|-------|------|-------------|---|
| reserved | 31:12 | rw | 0x0 | Reserved |
| PULLUP_EN | 11 | rw | 0x1 | enables pullup on output 0: no pullup 1: pullup enabled |
| OUTPUT_EN | 10:9 | rw | 0x0 | Enables output mode to enable output ties to 00: ibuf 01 and 10: reserved 11: obuf |
| TERM_DISABLE_MODE | 8 | rw | 0x0 | Termination is used during read transactions and may be disabled (automatically by hardware) when there are no reads taking place through the DDR Interface. Disabling termination reduces power consumption. 0: termination always enabled 1: use 'dynamic_dci_ts' to disable termination when not in use NOTE: This bit must be 0 during DRAM init/training. It may be set to 1 after init/training completes. |

| Field Name | Bits | Type | Reset Value | Description |
|-------------------|------|------|-------------|---|
| IBUF_DISABLE_MODE | 7 | rw | 0x0 | Use ibuf_disable_into control ibuf 0: ibuf is enabled 1: use ibuf_disable_in_to control enable NOTE: This must be 0 during DRAM init/training and can only be set to 1 after init/training completes. |
| DCI_TYPE | 6:5 | rw | 0x0 | DCI Mode Selection: 00: DCI Disabled (DDR2/3L ADDR and CLOCK) 01: DCI Drive (LPDDR2) 10: reserved 11: DCI Termination (DDR2/3/3L DATA and DIFF) |
| TERM_EN | 4 | rw | 0x0 | Tri State Termination Enable: 0: disable 1: enable |
| DCI_UPDATE_B | 3 | rw | 0x0 | DCI Update Enable: 0: disable 1: enable |
| INP_TYPE | 2:1 | rw | 0x0 | Input buffer control: 00: Input off (input signal to selected controller is driven Low). 01: Vref based differential receiver for SSTL, HSTL. 10: Differential input receiver. 11: LVCMOS receiver. |
| reserved | 0 | rw | 0x0 | Reserved. Do not modify. |

Register ([slcr](#)) DDRIOB_CLOCK

| | |
|------------------|---------------------------------|
| Name | DDRIOB_CLOCK |
| Relative Address | 0x00000B58 |
| Absolute Address | 0xF8000B58 |
| Width | 32 bits |
| Access Type | rw |
| Reset Value | 0x00000800 |
| Description | DDR IOB Config for Clock Output |

Register DDRIOB_CLOCK Details

| Field Name | Bits | Type | Reset Value | Description |
|------------|-------|------|-------------|---|
| reserved | 31:12 | rw | 0x0 | Reserved |
| PULLUP_EN | 11 | rw | 0x1 | enables pullup on output 0: no pullup 1: pullup enabled |

| Field Name | Bits | Type | Reset Value | Description |
|-------------------|------|------|-------------|---|
| OUTPUT_EN | 10:9 | rw | 0x0 | Enables output mode to enable output ties to 00: ibuf 01 and 10: reserved 11: obuf |
| TERM_DISABLE_MODE | 8 | rw | 0x0 | Termination is used during read transactions and may be disabled (automatically by hardware) when there are no reads taking place through the DDR Interface. Disabling termination reduces power consumption. 0: termination always enabled 1: use 'dynamic_dci_ts' to disable termination when not in use NOTE: This bit must be 0 during DRAM init/training. It may be set to 1 after init/training completes. |
| IBUF_DISABLE_MODE | 7 | rw | 0x0 | Use ibuf_disable_into control ibuf 0: ibuf is enabled 1: use ibuf_disable_in_to control enable NOTE: This must be 0 during DRAM init/training and can only be set to 1 after init/training completes. |
| DCI_TYPE | 6:5 | rw | 0x0 | DCI Mode Selection: 00: DCI Disabled (DDR2/3L ADDR and CLOCK) 01: DCI Drive (LPDDR2) 10: reserved 11: DCI Termination (DDR2/3/3L DATA and DIFF) |
| TERM_EN | 4 | rw | 0x0 | Tri State Termination Enable: 0: disable 1: enable |
| DCI_UPDATE_B | 3 | rw | 0x0 | DCI Update Enable: 0: disable 1: enable |
| INP_TYPE | 2:1 | rw | 0x0 | Input buffer control: 00: Input off (input signal to selected controller is driven Low). 01: Vref based differential receiver for SSTL, HSTL. 10: Differential input receiver. 11: LVCMOS receiver. |
| reserved | 0 | rw | 0x0 | Reserved. Do not modify. |

Register ([slcr](#)) DDRIOB_DRIVE_SLEW_ADDR

Name DDRIOB_DRIVE_SLEW_ADDR
Relative Address 0x00000B5C
Absolute Address 0xF8000B5C

| | |
|-------------|---|
| Width | 32 bits |
| Access Type | rw |
| Reset Value | 0x00000000 |
| Description | Drive and Slew controls for Address and Command pins of the DDR Interface |

Register DDRIOB_DRIVE_SLEW_ADDR Details

Value of this register is computed by EDK after taking into account the Silicon Revision and DDR Standard and can be found in the initialization TCL file or FSBL code. Values other than the one computed by EDK are not supported

| Field Name | Bits | Type | Reset Value | Description |
|------------|-------|------|-------------|--------------------------|
| reserved | 31:27 | rw | 0x0 | Reserved. Do not modify. |
| reserved | 26:24 | rw | 0x0 | Reserved. Do not modify. |
| reserved | 23:19 | rw | 0x0 | Reserved. Do not modify. |
| reserved | 18:14 | rw | 0x0 | Reserved. Do not modify. |
| reserved | 13:7 | rw | 0x0 | Reserved. Do not modify. |
| reserved | 6:0 | rw | 0x0 | Reserved. Do not modify. |

Register ([slcr](#)) DDRIOB_DRIVE_SLEW_DATA

| | |
|------------------|--|
| Name | DDRIOB_DRIVE_SLEW_DATA |
| Relative Address | 0x00000B60 |
| Absolute Address | 0xF8000B60 |
| Width | 32 bits |
| Access Type | rw |
| Reset Value | 0x00000000 |
| Description | Drive and Slew controls for DQ pins of the DDR Interface |

Register DDRIOB_DRIVE_SLEW_DATA Details

Value of this register is computed by EDK after taking into account the Silicon Revision and DDR Standard and can be found in the initialization TCL file or FSBL code. Values other than the one computed by EDK are not supported

| Field Name | Bits | Type | Reset Value | Description |
|------------|-------|------|-------------|--------------------------|
| reserved | 31:27 | rw | 0x0 | Reserved. Do not modify. |
| reserved | 26:24 | rw | 0x0 | Reserved. Do not modify. |
| reserved | 23:19 | rw | 0x0 | Reserved. Do not modify. |
| reserved | 18:14 | rw | 0x0 | Reserved. Do not modify. |

| Field Name | Bits | Type | Reset Value | Description |
|------------|------|------|-------------|--------------------------|
| reserved | 13:7 | rw | 0x0 | Reserved. Do not modify. |
| reserved | 6:0 | rw | 0x0 | Reserved. Do not modify. |

Register ([slcr](#)) DDRIOB_DRIVE_SLEW_DIFF

| | |
|------------------|---|
| Name | DDRIOB_DRIVE_SLEW_DIFF |
| Relative Address | 0x00000B64 |
| Absolute Address | 0xF8000B64 |
| Width | 32 bits |
| Access Type | rw |
| Reset Value | 0x00000000 |
| Description | Drive and Slew controls for DQS pins of the DDR Interface |

Register DDRIOB_DRIVE_SLEW_DIFF Details

Value of this register is computed by EDK after taking into account the Silicon Revision and DDR Standard and can be found in the initialization TCL file or FSBL code. Values other than the one computed by EDK are not supported

| Field Name | Bits | Type | Reset Value | Description |
|------------|-------|------|-------------|--------------------------|
| reserved | 31:27 | rw | 0x0 | Reserved. Do not modify. |
| reserved | 26:24 | rw | 0x0 | Reserved. Do not modify. |
| reserved | 23:19 | rw | 0x0 | Reserved. Do not modify. |
| reserved | 18:14 | rw | 0x0 | Reserved. Do not modify. |
| reserved | 13:7 | rw | 0x0 | Reserved. Do not modify. |
| reserved | 6:0 | rw | 0x0 | Reserved. Do not modify. |

Register ([slcr](#)) DDRIOB_DRIVE_SLEW_CLOCK

| | |
|------------------|---|
| Name | DDRIOB_DRIVE_SLEW_CLOCK |
| Relative Address | 0x00000B68 |
| Absolute Address | 0xF8000B68 |
| Width | 32 bits |
| Access Type | rw |
| Reset Value | 0x00000000 |
| Description | Drive and Slew controls for Clock pins of the DDR Interface |

Register DDRIOB_DRIVE_SLEW_CLOCK Details

Value of this register is computed by EDK after taking into account the Silicon Revision and DDR Standard and can be found in the initialization TCL file or FSBL code. Values other than the one computed by EDK are not supported

| Field Name | Bits | Type | Reset Value | Description |
|------------|-------|------|-------------|--------------------------|
| reserved | 31:27 | rw | 0x0 | Reserved. Do not modify. |
| reserved | 26:24 | rw | 0x0 | Reserved. Do not modify. |
| reserved | 23:19 | rw | 0x0 | Reserved. Do not modify. |
| reserved | 18:14 | rw | 0x0 | Reserved. Do not modify. |
| reserved | 13:7 | rw | 0x0 | Reserved. Do not modify. |
| reserved | 6:0 | rw | 0x0 | Reserved. Do not modify. |

Register ([slcr](#)) DDRIOB_DDR_CTRL

| | |
|------------------|------------------------|
| Name | DDRIOB_DDR_CTRL |
| Relative Address | 0x00000B6C |
| Absolute Address | 0xF8000B6C |
| Width | 32 bits |
| Access Type | rw |
| Reset Value | 0x00000000 |
| Description | DDR IOB Buffer Control |

Register DDRIOB_DDR_CTRL Details

| Field Name | Bits | Type | Reset Value | Description |
|-------------|-------|------|-------------|---|
| reserved | 31:15 | rw | 0x0 | reserved |
| reserved | 14 | rw | 0x0 | Reserved. Do not modify. |
| reserved | 13 | rw | 0x0 | Reserved. Do not modify. |
| reserved | 12 | rw | 0x0 | Reserved. Do not modify. |
| reserved | 11:10 | rw | 0x0 | Reserved. Do not modify. |
| REFIO_EN | 9 | rw | 0x0 | Enables VRP,VRN 0: VRP/VRN not used 1: VRP/VRN used as refio |
| reserved | 8:7 | rw | 0x0 | Reserved. Do not modify. |
| VREF_EXT_EN | 6:5 | rw | 0x0 | Enables External VREF input x0: Disable External VREF for lower 16 bits x1: Enable External VREF for lower 16 bits 0x: Disable External VREF for upper 16 bits 1x: Enable External VREF for upper 16 bits |

| Field Name | Bits | Type | Reset Value | Description |
|-------------|------|------|-------------|--|
| VREF_SEL | 4:1 | rw | 0x0 | Specifies DDR IOB Vref generator output: 0001: VREF = 0.6V for LPDDR2 with 1.2V IO 0010: VREF = 0.675V for DDR3L with 1.35V IO 0100: VREF = 0.75V for DDR3 with 1.5V IO 1000: VREF = 0.90V for DDR2 with 1.8V IO |
| VREF_INT_EN | 0 | rw | 0x0 | Enables VREF internal generator |

Register ([slcr](#)) DDRIOB_DCI_CTRL

| | |
|------------------|--------------------|
| Name | DDRIOB_DCI_CTRL |
| Relative Address | 0x00000B70 |
| Absolute Address | 0xF8000B70 |
| Width | 32 bits |
| Access Type | rw |
| Reset Value | 0x00000020 |
| Description | DDR IOB DCI Config |

Register DDRIOB_DCI_CTRL Details

| Field Name | Bits | Type | Reset Value | Description |
|----------------|-------|------|-------------|---|
| reserved | 31:28 | rw | 0x0 | Reserved. Writes are ignored, read data is zero. |
| reserved | 27 | rw | 0x0 | Reserved. Do not modify. |
| reserved | 26 | rw | 0x0 | Reserved. Do not modify. |
| reserved | 25 | rw | 0x0 | Reserved. Do not modify. |
| reserved | 24 | rw | 0x0 | Reserved. Do not modify. |
| reserved | 23 | rw | 0x0 | Reserved. Do not modify. |
| reserved | 22 | rw | 0x0 | Reserved. Do not modify. |
| reserved | 21 | rw | 0x0 | Reserved. Do not modify. |
| UPDATE_CONTROL | 20 | rw | 0x0 | DCI Update Mode. Use the values in the Calibration Table. |
| PREF_OPT2 | 19:17 | rw | 0x0 | DCI Calibration. Use the values in the Calibration Table. |
| reserved | 16 | rw | 0x0 | Reserved |
| PREF_OPT1 | 15:14 | rw | 0x0 | DCI Calibration. Use the values in the Calibration Table. |
| NREF_OPT4 | 13:11 | rw | 0x0 | DCI Calibration. Use the values in the Calibration Table. |
| NREF_OPT2 | 10:8 | rw | 0x0 | DCI Calibration. Use the values in the Calibration Table. |

| Field Name | Bits | Type | Reset Value | Description |
|------------|------|------|-------------|--|
| NREF_OPT1 | 7:6 | rw | 0x0 | DCI Calibration. Use the values in the Calibration Table. |
| reserved | 5 | rw | 0x1 | Reserved. Do not modify. |
| reserved | 4 | rw | 0x0 | Reserved. Do not modify. |
| reserved | 3 | rw | 0x0 | Reserved. Do not modify. |
| reserved | 2 | rw | 0x0 | Reserved. Do not modify. |
| ENABLE | 1 | rw | 0x0 | DCI System Enable. Set to 1 if any IOs in DDR IO Bank use DCI Termination. DDR2, DDR3, DDR3L and LPDDR2 (Silicon Revision 2.0+) configurations require this bit set to 1 |
| RESET | 0 | rw | 0x0 | At least toggle once to initialize flops in DCI system |

Register ([slcr](#)) DDRIOB_DCI_STATUS

| | |
|------------------|--------------------------|
| Name | DDRIOB_DCI_STATUS |
| Relative Address | 0x00000B74 |
| Absolute Address | 0xF8000B74 |
| Width | 32 bits |
| Access Type | mixed |
| Reset Value | 0x00000000 |
| Description | DDR IO Buffer DCI Status |

Register DDRIOB_DCI_STATUS Details

| Field Name | Bits | Type | Reset Value | Description |
|------------|-------|------|-------------|--|
| reserved | 31:14 | ro | 0x0 | Reserved. Writes are ignored, read data is zero. |
| DONE | 13 | rw | 0x0 | DCI done signal |
| reserved | 12 | rw | 0x0 | Reserved. Do not modify. |
| reserved | 11 | rw | 0x0 | Reserved. Do not modify. |
| reserved | 10 | ro | 0x0 | Reserved. Do not modify. |
| reserved | 9 | ro | 0x0 | Reserved. Do not modify. |
| reserved | 8 | ro | 0x0 | Reserved. Do not modify. |
| reserved | 7 | ro | 0x0 | Reserved. Do not modify. |
| reserved | 6 | ro | 0x0 | Reserved. Do not modify. |
| reserved | 5 | ro | 0x0 | Reserved. Do not modify. |
| reserved | 4:3 | ro | 0x0 | Reserved. Do not modify. |
| reserved | 2 | ro | 0x0 | Reserved. Do not modify. |

| Field Name | Bits | Type | Reset Value | Description |
|------------|------|------|-------------|----------------------------|
| reserved | 1 | ro | 0x0 | Reserved. Do not modify. |
| LOCK | 0 | ro | 0x0 | DCI Status input Read Only |

B.29 Static Memory Controller (pl353)

| | |
|---------------|----------------------------------|
| Module Name | Static Memory Controller (pl353) |
| Software Name | XNANDPS |
| Base Address | 0xE000E000 smcc |
| Description | Shared memory controller |
| Vendor Info | |

Register Summary

| Register Name | Address | Width | Type | Reset Value | Description |
|--|------------|-------|-------|-------------|--|
| XNANDPS_MEMC_STAT_US_OFFSET | 0x00000000 | 13 | ro | 0x00000000 | Operating and Interrupt Status |
| XNANDPS_MEMC_IF_CONFIG_OFFSET | 0x00000004 | 18 | ro | 0x00011205 | SMC configuration information |
| XNANDPS_MEMC_SET_CONFIG_OFFSET | 0x00000008 | 7 | wo | x | Enable interrupts and lower power state |
| XNANDPS_MEMC_CLR_CONFIG_OFFSET | 0x0000000C | 7 | wo | x | Disable interrupts and exit from low-power state |
| XNANDPS_DIRECT_CMD_OFFSET | 0x00000010 | 26 | wo | x | Issue mem commands and register updates |
| XNANDPS_SET_CYCLES_OFFSET | 0x00000014 | 24 | wo | x | Stage a write to a Cycle register |
| XNANDPS_SET_OPMODE_OFFSET | 0x00000018 | 16 | mixed | x | Stage a write to an OpMode register |
| XNANDPS_REFRESH_PERIOD_0_OFFSET | 0x00000020 | 4 | rw | 0x00000000 | Idle cycles between read/write bursts |
| XNANDPS_REFRESH_PERIOD_1_OFFSET | 0x00000024 | 4 | rw | 0x00000000 | Insert idle cycles between bursts |
| XNANDPS_IF0_CHIP_0_CONFIG_OFFSET | 0x00000100 | 21 | ro | 0x0002B3CC | SRAM/NOR chip select 0 timing, active |
| XNANDPS_OPMODE | 0x00000104 | 32 | ro | 0xE2FE0800 | SRAM/NOR chip select 0 OpCode, active |
| XNANDPS_IF0_CHIP_1_CONFIG_OFFSET | 0x00000120 | 21 | ro | 0x0002B3CC | SRAM/NOR chip select 1 timing, active |
| opmode0_1 | 0x00000124 | 32 | ro | 0xE4FE0800 | SRAM/NOR chip select 1 OpCode, active |
| XNANDPS_IF1_CHIP_0_CONFIG_OFFSET | 0x00000180 | 24 | ro | 0x0024ABCC | NAND Flash timing, active |
| opmode1_0 | 0x00000184 | 32 | ro | 0xE1FF0001 | NAND Flash OpCode, active |
| XNANDPS_USER_STATUS_OFFSET | 0x00000200 | 8 | ro | 0x00000000 | User Status Register |

| Register Name | Address | Width | Type | Reset Value | Description |
|--|------------|-------|------|-------------|-------------------------------------|
| XNANDPS_USER_CONFIG_OFFSET | 0x00000204 | 8 | wo | x | User Configuration Register |
| XNANDPS_IF1_ECC_OFFSET | 0x00000400 | 30 | ro | 0x00000000 | ECC Status and Clear Register 1 |
| ecc_memcfg_1 | 0x00000404 | 13 | rw | 0x00000043 | ECC Memory Configuration Register 1 |
| ecc_memcommand1_1 | 0x00000408 | 25 | rw | 0x01300080 | ECC Memory Command 1 Register 1 |
| ecc_memcommand2_1 | 0x0000040C | 25 | rw | 0x01E00585 | ECC Memory Command 2 Register 1 |
| ecc_addr0_1 | 0x00000410 | 32 | ro | 0x00000000 | ECC Address 0 Register 1 |
| ecc_addr1_1 | 0x00000414 | 24 | ro | 0x00000000 | ECC Address 1 Register 1 |
| ecc_value0_1 | 0x00000418 | 32 | ro | 0x00000000 | ECC Value 0 Register 1 |
| ecc_value1_1 | 0x0000041C | 32 | ro | 0x00000000 | ECC Value 1 Register 1 |
| ecc_value2_1 | 0x00000420 | 32 | ro | 0x00000000 | ECC Value 2 Register 1 |
| ecc_value3_1 | 0x00000424 | 32 | ro | 0x00000000 | ECC Value 3 Register 1 |

Register ([p1353](#)) XNANDPS_MEMC_STATUS_OFFSET

| | |
|------------------|--------------------------------|
| Name | XNANDPS_MEMC_STATUS_OFFSET |
| Software Name | MEMC_STATUS |
| Relative Address | 0x00000000 |
| Absolute Address | 0xE000E000 |
| Width | 13 bits |
| Access Type | ro |
| Reset Value | 0x00000000 |
| Description | Operating and Interrupt Status |

Register XNANDPS_MEMC_STATUS_OFFSET Details

The read-only memc_status Register provides information on the configuration of the SMC and also the current state of the SMC. You cannot read this register in the Reset state

| Field Name | Bits | Type | Reset Value | Description |
|--|------|------|-------------|--|
| XNANDPS_MEMC_STATUS_RAW_ECC_INT1_MASK (RAW_ECC_INT1) | 12 | ro | 0x0 | NAND Flash ECC interrupt raw status: 0: Not asserted 1: Asserted |
| reserved | 11 | ro | 0x0 | Reserved. Do not modify. |

| Field Name | Bits | Type | Reset Value | Description |
|---|------|------|-------------|---|
| XNANDPS_MEMC_STAT_US_ECC_INT1_MASK (ECC_INT1) | 10 | ro | 0x0 | NAND Flash ECC interrupt status after mask/enable: 0: Not asserted 1: Asserted |
| reserved | 9 | ro | 0x0 | Reserved. Do not modify. |
| XNANDPS_MEMC_STAT_US_ECC_INT_EN1_MASK (ECC_INT_EN1) | 8 | ro | 0x0 | NAND Flash ECC interrupt enable setting: 0: Masked 1: Enabled |
| reserved | 7 | ro | 0x0 | Reserved. Do not modify. |
| XNANDPS_MEMC_STAT_US_RAW_INT_STATUS1_MASK (RAW_INT_STATUS1) | 6 | ro | 0x0 | NAND Flash raw interrupt status before mask/enable: 0: Not asserted 1: Asserted |
| XNANDPS_MEMC_STAT_US_RAW_INT_STATUS0_MASK (RAW_INT_STATUS0) | 5 | ro | 0x0 | SRAM/NOR raw interrupt raw status before the mask/enable: 0: Not asserted 1: Asserted |
| XNANDPS_MEMC_STAT_US_INT_STATUS1_MASK (INT_STATUS1) | 4 | ro | 0x0 | NAND Flash interrupt status after the mask/enable: 0: Not asserted 1: Asserted |
| XNANDPS_MEMC_STAT_US_INT_STATUS0_MASK (INT_STATUS0) | 3 | ro | 0x0 | SRAM/NOR interrupt status after the mask/enable : 0: Not asserted 1: Asserted |
| XNANDPS_MEMC_STAT_US_INT_EN1_MASK (INT_EN1) | 2 | ro | 0x0 | NAND Flash interrupt enable status: 0: Disabled 1: Enabled |
| XNANDPS_MEMC_STAT_US_INT_EN0_MASK (INT_EN0) | 1 | ro | 0x0 | SRAM/NOR interface interrupt enable setting: 0: Disabled 1: Enabled |
| XNANDPS_MEMC_STAT_US_STATE_MASK (STATE) | 0 | ro | 0x0 | SMC operating state: 0: Normal 1: Low-power state |

Register ([p1353](#)) XNANDPS_MEMC_IF_CONFIG_OFFSET

| | |
|------------------|-------------------------------|
| Name | XNANDPS_MEMC_IF_CONFIG_OFFSET |
| Software Name | MEMC_IF_CONFIG |
| Relative Address | 0x00000004 |
| Absolute Address | 0xE000E004 |
| Width | 18 bits |

| | |
|-------------|-------------------------------|
| Access Type | ro |
| Reset Value | 0x00011205 |
| Description | SMC configuration information |

Register XNANDPS_MEMC_IF_CONFIG_OFFSET Details

Provides information on the configuration of the memory interface. You cannot read this register in the Reset state. The state of this register cannot be changed.

| Field Name | Bits | Type | Reset Value | Description |
|---|-------|------|-------------|---|
| XNANDPS_MEMC_IF_CONFIG_EX_MONITORS_MASK (EX_MONITORS) | 17:16 | ro | 0x1 | Return the number of exclusive access monitor resources that are implemented in the SMC. B00: 0 monitors b01: 1 monitor b10: 2 monitors b11: 4 monitors |
| reserved | 15 | ro | 0x0 | Reserved |
| XNANDPS_MEMC_IF_CONFIG_REMAP1_MASK (REMAP1) | 14 | ro | 0x0 | Return the value of the remap_1 input. |
| XNANDPS_MEMC_IF_CONFIG_MEMORY_WIDTH_H1_MASK (MEMORY_WIDTHH1) | 13:12 | ro | 0x1 | The width of the NAND Flash interface can be 8 or 16 bits. 00: 8 Bit Interface 01: 16 Bit Interface |
| XNANDPS_MEMC_IF_CONFIG_MEMORY_CHIP_S1_MASK (MEMORY_CHIPS1) | 11:10 | ro | 0x0 | The NAND Flash interface provides one chip select. |
| XNANDPS_MEMC_IF_CONFIG_MEMORY_TYPE_1_MASK (MEMORY_TYPE1) | 9:8 | ro | 0x2 | SMC controller 1 supports the NAND Flash interface with hardware assisted ECC. |
| reserved | 7 | ro | 0x0 | Reserved |
| XNANDPS_MEMC_IF_CONFIG_REMAP0_MASK (REMAP0) | 6 | ro | 0x0 | Return the value of the remap_0 input |
| XNANDPS_MEMC_IF_CONFIG_MEMORY_WIDTH_H0_MASK (MEMORY_WIDTHH0) | 5:4 | ro | 0x0 | The width of the SRAM/NOR interface is 8 bits. |

| Field Name | Bits | Type | Reset Value | Description |
|--|------|------|-------------|--|
| XNANDPS_MEMC_IF_C ONFIG_MEMORY_CHIP S0_MASK (MEMORY_CHIPS0) | 3:2 | ro | 0x1 | The SRAM/NOR interface provides two chip selects. Reads as {0,1} |
| XNANDPS_MEMC_IF_C ONFIG_MEMORY_TYPE 0_MASK (MEMORY_TYPE0) | 1:0 | ro | 0x1 | SMC controller 0 supports the SRAM/NOR interface. |

Register ([pl353](#)) XNANDPS_MEMC_SET_CONFIG_OFFSET

| | |
|------------------|---|
| Name | XNANDPS_MEMC_SET_CONFIG_OFFSET |
| Software Name | MEMC_SET_CONFIG |
| Relative Address | 0x00000008 |
| Absolute Address | 0xE000E008 |
| Width | 7 bits |
| Access Type | wo |
| Reset Value | x |
| Description | Enable interrupts and lower power state |

Register XNANDPS_MEMC_SET_CONFIG_OFFSET Details

The write-only memc_cfg_set enables the SMC to be changed to low-power state, and interrupts enabled. You cannot write to this register in the Reset state.

| Field Name | Bits | Type | Reset Value | Description |
|---|------|------|-------------|---|
| XNANDPS_MEMC_SET_CONFIG_ECC_INT_ENABLE1_MASK (ECC_INT_ENABLE1) | 6 | wo | x | NAND Flash ECC interrupt enable: 0: No change 1: Enable |
| reserved | 5 | wo | x | Reserved. Do not modify. |
| reserved | 4:3 | wo | x | Reserved, write as zero. |
| XNANDPS_MEMC_SET_CONFIG_LOW_POWER_REQ_MASK (LOW_POWER_REQ) | 2 | wo | x | Put SMC into low-power mode when memory interface goes idle: 0: No change 1: Enable low-power state |

| Field Name | Bits | Type | Reset Value | Description |
|---|------|------|-------------|---|
| XNANDPS_MEMC_SET_CONFIG_INT_ENABLE1_MASK (INT_ENABLE1) | 1 | wo | x | NAND Flash interrupt enable: 0: No change 1: Enable |
| XNANDPS_MEMC_SET_CONFIG_INT_ENABLE0_MASK (INT_ENABLE0) | 0 | wo | x | SRAM/NOR interrupt enable: 0: No change 1: Enable |

Register ([pl353](#)) XNANDPS_MEMC_CLR_CONFIG_OFFSET

| | |
|------------------|--|
| Name | XNANDPS_MEMC_CLR_CONFIG_OFFSET |
| Software Name | MEMC_CLR_CONFIG |
| Relative Address | 0x0000000C |
| Absolute Address | 0xE000E00C |
| Width | 7 bits |
| Access Type | wo |
| Reset Value | x |
| Description | Disable interrupts and exit from low-power state |

Register XNANDPS_MEMC_CLR_CONFIG_OFFSET Details

The write-only memc_cfg_clr enables the SMC to be moved out of the low-power state, and the interrupts disabled. You cannot write to this register in the Reset state.

| Field Name | Bits | Type | Reset Value | Description |
|---|------|------|-------------|--|
| XNANDPS_MEMC_CLR_CONFIG_ECC_INT_DISABLE1_MASK (ECC_INT_DISABLE1) | 6 | wo | x | NAND Flash ECC interrupt disable: 0: No change 1: Disable |
| reserved | 5 | wo | x | Reserved. Do not modify. |
| XNANDPS_MEMC_CLR_CONFIG_INT_CLR1_MASK (INT_CLR1) | 4 | wo | x | 0: No effect 1: Clear SMC Interrupt 1 as an alternative to an AXI read |
| XNANDPS_MEMC_CLR_CONFIG_INT_CLR0_MASK (INT_CLR0) | 3 | wo | x | 0: No effect 1: Clear SMC Interrupt 0 as an alternative to an AXI read |
| XNANDPS_MEMC_CLR_CONFIG_LOW_POWER_EXIT_MASK (LOW_POWER_EXIT) | 2 | wo | x | Exit low-power mode. The affect takes place when memory interface goes idle: 0: No change 1: Exit from low-power state |

| Field Name | Bits | Type | Reset Value | Description |
|---|------|------|-------------|--|
| XNANDPS_MEMC_CLR_CONFIG_INT_DISABLE1_MASK (INT_DISABLE1) | 1 | wo | x | NAND Flash interrupt disable: 0: No change 1: disable (apply mask) |
| XNANDPS_MEMC_CLR_CONFIG_INT_DISABLE0_MASK (INT_DISABLE0) | 0 | wo | x | SRAM/NOR interrupt disable: 0: No change 1: disable (apply mask) |

Register ([pl353](#)) XNANDPS_DIRECT_CMD_OFFSET

| | |
|------------------|---|
| Name | XNANDPS_DIRECT_CMD_OFFSET |
| Software Name | DIRECT_CMD |
| Relative Address | 0x00000010 |
| Absolute Address | 0xE000E010 |
| Width | 26 bits |
| Access Type | wo |
| Reset Value | x |
| Description | Issue mem commands and register updates |

Register XNANDPS_DIRECT_CMD_OFFSET Details

The write-only `direct_cmd` passes commands to the external memory, and controls the updating of the chip configuration registers with values held in the `set_cycles` Register and `set_opmode` Register. You cannot write to this register in either the Reset or low-power states.

Note: Arm's PL353 documentation has different timing naming convention (used in `SET_CYCLES` register) than ONFI Specification 1.0.

| Field Name | Bits | Type | Reset Value | Description |
|--|-------|------|-------------|---|
| XNANDPS_DIRECT_CMD_CHIP_SELECT_MASK (CHIP_SELECT) | 25:23 | wo | x | Select register bank to update and enable chip mode register access based on <code>CMD_TYPE</code> : 000: SRAM/NOR chip select 0. 001: SRAM/NOR chip select 1. 100: NAND Flash. others: reserved. |
| XNANDPS_DIRECT_CMD_TYPE_MASK (TYPE) | 22:21 | wo | x | Select the command type: 00: UpdateRegs and AXI 01: ModeReg 10: UpdateRegs 11: ModeReg and UpdateRegs |

| Field Name | Bits | Type | Reset Value | Description |
|-------------------------------------|------|------|-------------|--|
| reserved | 20 | wo | x | Reserved. Do not modify. |
| XNANDPS_DIRECT_CMD_ADDR_MASK (ADDR) | 19:0 | wo | x | When cmd_type = UpdateRegs and AXI then: Bits [15:0] are used to match wdata[15:0] Bits [19:16] are reserved. Write as zero. When cmd_type = ModeReg or ModeReg and UpdateRegs, these bits map to the external memory address bits [19:0]. When cmd_type = UpdateRegs, these bits are reserved. Write as zero. |

Register ([pl353](#)) XNANDPS_SET_CYCLES_OFFSET

| | |
|------------------|-----------------------------------|
| Name | XNANDPS_SET_CYCLES_OFFSET |
| Software Name | SET_CYCLES |
| Relative Address | 0x00000014 |
| Absolute Address | 0xE000E014 |
| Width | 24 bits |
| Access Type | wo |
| Reset Value | x |
| Description | Stage a write to a Cycle register |

Register XNANDPS_SET_CYCLES_OFFSET Details

This write-only register contains values that are written to the sram_cycles register or nand_cycles when the SMC receives a write to the Direct Command Register. You cannot write to this register in either the Reset or low-power states.

| Field Name | Bits | Type | Reset Value | Description |
|---|-------|------|-------------|--|
| XNANDPS_SET_CYCLES_SET_T6_MASK (SET_T6) | 23:20 | wo | x | Timing parameter for SRAM/NOR, bit 20 only (other bits are ignored): o For asynchronous multiplexed transfers this bit controls when the SMC asserts we_n: 0: assert we_n two mclk cycles after asserting cs_n. 1: assert we_n and cs_n together. Timing parameter for NAND Flash, bits 23:20: o Busy to RE timing (t_rr), minimum permitted value = 0. |
| XNANDPS_SET_CYCLES_SET_T5_MASK (SET_T5) | 19:17 | wo | x | Timing parameter for SRAM/NOR: o Turnaround time (t_ta), minimum value = 1. Timing parameter for NAND Flash: o ID read time (t_ar), minimum value = 0. |

| Field Name | Bits | Type | Reset Value | Description |
|---|-------|------|-------------|--|
| XNANDPS_SET_CYCLES_SET_T4_MASK (SET_T4) | 16:14 | wo | x | Timing parameter for SRAM/NOR: o Page cycle time (t _{pc}), minimum value = 1. Timing parameter for NAND Flash: o Page cycle time (t _{clr}), minimum value = 1. |
| XNANDPS_SET_CYCLES_SET_T3_MASK (SET_T3) | 13:11 | wo | x | Timing parameter for SRAM/NOR: o Write Enable (t _{wp}) assertion delay, minimum value = 1. Timing parameter for NAND Flash: o Write Enable (t _{wp}) deassertion delay, minimum value = 1. |
| XNANDPS_SET_CYCLES_SET_T2_MASK (SET_T2) | 10:8 | wo | x | Timing parameter for SRAM/NOR: o Output Enable (t _{ceoe}) assertion delay, minimum value = 1. Timing parameter for NAND Flash: o REA (t _{rea}) assertion delay, minimum value = 1. |
| XNANDPS_SET_CYCLES_SET_T1_MASK (SET_T1) | 7:4 | wo | x | Timing parameter for SRAM/NOR and NAND Flash: Write cycle time, minimum value = 2. |
| XNANDPS_SET_CYCLES_SET_T0_MASK (SET_T0) | 3:0 | wo | x | Timing parameter for SRAM/NOR and NAND Flash: Read cycle time, minimum value = 2. |

Register (p1353) XNANDPS_SET_OPMODE_OFFSET

| | |
|------------------|-------------------------------------|
| Name | XNANDPS_SET_OPMODE_OFFSET |
| Software Name | SET_OPMODE |
| Relative Address | 0x00000018 |
| Absolute Address | 0xE000E018 |
| Width | 16 bits |
| Access Type | mixed |
| Reset Value | x |
| Description | Stage a write to an OpMode register |

Register XNANDPS_SET_OPMODE_OFFSET Details

This write-only register is the holding register for the opmode <x>_<n> Registers. You cannot write to it in either the Reset or low-power states.

| Field Name | Bits | Type | Reset Value | Description |
|---|-------|------|-------------|---|
| reserved | 15:13 | wo | x | Reserved. Do not modify. |
| XNANDPS_SET_OPMODE_SET_BLS_MASK (SET_BLS) | 12 | wo | x | NAND Flash: reserved, write zero. SRAM/NOR: Value written to the byte lane strobe (bls) bit. This bit affects the assertion of the byte-lane strobe outputs. 0: bls timing equals chip select timing. This is the default setting. 1: bls timing equals we_n timing. This setting is used for eight memories that have no bls_n inputs. In this case, the bls_n output of the SMC is connected to the we_n memory input. |
| XNANDPS_SET_OPMODE_SET_ADV_MASK (SET_ADV) | 11 | wo | x | Contains the value to be written to the specific SRAM chip opmode Register address valid (adv) bit. The memory uses the address advance signal adv_n when set. For a NAND memory interface this bit is reserved, and written as zero. |
| XNANDPS_SET_OPMODE_SET_BAA_MASK (SET_BAA) | 10 | rw | x | NAND Flash: reserved, write zero. SRAM/NOR: Value written burst address advance (baa) bit. The memory uses the baa_n signal when set. |
| XNANDPS_SET_OPMODE_SET_WR_BL_MASK (SET_WR_BL) | 9:7 | wo | x | NAND Flash: reserved, write zero. SRAM/NOR: Value written for wr_bl : 000: 1 beat 001: 4 beats 010: 8 beats 011: 16 beats 100: 32 beats 101: continuous others: reserved. |
| reserved | 6 | wo | x | Reserved. Do not modify. |
| XNANDPS_SET_OPMODE_SET_RD_BL_MASK (SET_RD_BL) | 5:3 | wo | x | NAND Flash: reserved, write zero. SRAM/NOR: value written to opmode (rd_bl field). Memory Burst Length: 000: 1 beat 001: 4 beats 010: 8 beats 011: 16 beats 100: 32 beats 101: continuous others: reserved |
| reserved | 2 | wo | x | Reserved. Do not modify. |
| XNANDPS_SET_OPMODE_SET_MW_MASK (SET_MW) | 1:0 | wo | x | SRAM/NOR: mw= 00 (8-bit) NAND Flash: mw= 00 (8-bit) or 01 (16-bit) |

Register ([p1353](#)) XNANDPS_REFRESH_PERIOD_0_OFFSET

| | |
|------------------|---------------------------------------|
| Name | XNANDPS_REFRESH_PERIOD_0_OFFSET |
| Software Name | REFRESH_PERIOD_0 |
| Relative Address | 0x00000020 |
| Absolute Address | 0xE000E020 |
| Width | 4 bits |
| Access Type | rw |
| Reset Value | 0x00000000 |
| Description | Idle cycles between read/write bursts |

Register XNANDPS_REFRESH_PERIOD_0_OFFSET Details

The read/write refresh_period_0 enables the SMC to insert idle cycles during consecutive bursts, that enables the PSRAM devices on memory interface 0, to initiate a refresh cycle. You cannot access this register in either the Reset or low-power states. Note:

You can only access this register when you are using an SRAM memory interface.

| Field Name | Bits | Type | Reset Value | Description |
|--------------------------------------|------|------|-------------|---|
| XNANDPS_REFRESH_PERIOD_0_MASK (MASK) | 3:0 | rw | 0x0 | Set the number of consecutive memory bursts that are permitted, prior to the SMC deasserting chip select to enable the PSRAM to initiate a refresh cycle. The options are: b0000: disable the insertion of idle cycles between consecutive bursts b0001: an idle cycle occurs after each burst b0010: an idle cycle occurs after 2 consecutive bursts b0011: an idle cycle occurs after 3 consecutive bursts b0100: an idle cycle occurs after 4 consecutive bursts ... b1111: an idle cycle occurs after 15 consecutive bursts. |

Register ([p1353](#)) XNANDPS_REFRESH_PERIOD_1_OFFSET

| | |
|------------------|---------------------------------|
| Name | XNANDPS_REFRESH_PERIOD_1_OFFSET |
| Software Name | REFRESH_PERIOD_1 |
| Relative Address | 0x00000024 |
| Absolute Address | 0xE000E024 |
| Width | 4 bits |
| Access Type | rw |

Reset Value 0x00000000
 Description Insert idle cycles between bursts

Register XNANDPS_REFRESH_PERIOD_1_OFFSET Details

The read/write refresh_period_1 Register enables the SMC to insert idle cycles during consecutive bursts, that enables the PSRAM devices on memory interface 1, to initiate a refresh cycle

| Field Name | Bits | Type | Reset Value | Description |
|--|------|------|-------------|---|
| XNANDPS_REFRESH_PERIOD_0_MASK (REFRESH_PERIOD_0) | 3:0 | rw | 0x0 | Set the number of consecutive memory bursts that are permitted, prior to the SMC deasserting chip select to enable the PSRAM to initiate a refresh cycle. The options are: b0000: disable the insertion of idle cycles between consecutive bursts b0001: an idle cycle occurs after each burst b0010: an idle cycle occurs after 2 consecutive bursts b0011: an idle cycle occurs after 3 consecutive bursts b0100: an idle cycle occurs after 4 consecutive bursts ... b1111: an idle cycle occurs after 15 consecutive bursts. |

Register ([p1353](#)) XNANDPS_IF0_CHIP_0_CONFIG_OFFSET

Name XNANDPS_IF0_CHIP_0_CONFIG_OFFSET
 Software Name IF0_CHIP_0_CONFIG
 Relative Address 0x00000100
 Absolute Address 0xE000E100
 Width 21 bits
 Access Type ro
 Reset Value 0x0002B3CC
 Description SRAM/NOR chip select 0 timing, active

Register XNANDPS_IF0_CHIP_0_CONFIG_OFFSET Details

There is an instance of this register for each SRAM chip supported. You cannot read the read-only sram_cycles Register in the Reset state

| Field Name | Bits | Type | Reset Value | Description |
|------------|-------|------|-------------|---|
| we_time | 20 | ro | 0x0 | Asynchronous assertion, refer to SET_CYCLES register. |
| t_tr | 19:17 | ro | 0x1 | Turnaround time, refer to SET_CYCLES register. |
| t_pc | 16:14 | ro | 0x2 | Page cycle time, refer to SET_CYCLES register. |
| t_wp | 13:11 | ro | 0x6 | WE assertion delay, refer to SET_CYCLES register. |
| t_ceoe | 10:8 | ro | 0x3 | OE assertion delay, refer to SET_CYCLES register. |
| t_wc | 7:4 | ro | 0xC | Write cycle time, refer to SET_CYCLES register. |
| t_rc | 3:0 | ro | 0xC | Read cycle time, refer to SET_CYCLES register. |

Register ([pl353](#)) XNANDPS_OPMODE

| | |
|------------------|---------------------------------------|
| Name | XNANDPS_OPMODE |
| Software Name | OPMODE |
| Relative Address | 0x00000104 |
| Absolute Address | 0xE000E104 |
| Width | 32 bits |
| Access Type | ro |
| Reset Value | 0xE2FE0800 |
| Description | SRAM/NOR chip select 0 OpCode, active |

Register XNANDPS_OPMODE Details

| Field Name | Bits | Type | Reset Value | Description |
|--|-------|------|-------------|---|
| XNANDPS_OPMODE_A DDRESS_MATCH_MASK (ADDRESS_MATCH) | 31:24 | ro | 0xE2 | Return the value of this tie-off. This is the comparison value for address bits [31:24] to determine the chip that is selected. |
| XNANDPS_OPMODE_A DDRESS_MASK (ADDRESS) | 23:16 | ro | 0xFE | Return the value of this tie-off. This is the mask for address bits[31:24] to determine the chip that must be selected. A logic 1 indicates the bit is used for comparison. |
| reserved | 15:13 | ro | 0x0 | Reserved. Do not modify. |
| reserved | 12 | ro | 0x0 | Reserved. Do not modify. |
| reserved | 11 | ro | 0x1 | Reserved. Do not modify. |
| XNANDPS_OPMODE_B AA_MASK (BAA) | 10 | ro | 0x0 | The memory uses the burst address advance signal, baa_n, when set. For a NAND memory interface, this bit is reserved. |
| XNANDPS_OPMODE_W R_BL_MASK (WR_BL) | 9:7 | ro | 0x0 | Selects the write burst lengths, see SET_OPMODE register. |
| reserved | 6 | ro | 0x0 | Reserved. Do not modify. |

| Field Name | Bits | Type | Reset Value | Description |
|-----------------------------------|------|------|-------------|---|
| XNANDPS_OPMODE_RD_BL_MASK (RD_BL) | 5:3 | ro | 0x0 | Select memory burst lengths, see SET_OPMODE Register. |
| reserved | 2 | ro | 0x0 | Reserved. Do not modify. |
| XNANDPS_OPMODE_MW_MASK (MW) | 1:0 | ro | 0x0 | Select data bus width (8 or 16), see SET_OPMODE register. |

Register (pl353) XNANDPS_IF0_CHIP_1_CONFIG_OFFSET

| | |
|------------------|---------------------------------------|
| Name | XNANDPS_IF0_CHIP_1_CONFIG_OFFSET |
| Software Name | IF0_CHIP_1_CONFIG |
| Relative Address | 0x00000120 |
| Absolute Address | 0xE000E120 |
| Width | 21 bits |
| Access Type | ro |
| Reset Value | 0x0002B3CC |
| Description | SRAM/NOR chip select 1 timing, active |

Register XNANDPS_IF0_CHIP_1_CONFIG_OFFSET Details

There is an instance of this register for each SRAM chip supported. You cannot read the read-only sram_cycles Register in the Reset state

| Field Name | Bits | Type | Reset Value | Description |
|------------|-------|------|-------------|---|
| we_time | 20 | ro | 0x0 | Asynchronous assertion, refer to SET_CYCLES register. |
| t_tr | 19:17 | ro | 0x1 | Turnaround time, refer to SET_CYCLES register. |
| t_pc | 16:14 | ro | 0x2 | Page cycle time, refer to SET_CYCLES register. |
| t_wp | 13:11 | ro | 0x6 | WE assertion delay, refer to SET_CYCLES register. |
| t_ceoe | 10:8 | ro | 0x3 | OE assertion delay, refer to SET_CYCLES register. |
| t_wc | 7:4 | ro | 0xC | Write cycle time, refer to SET_CYCLES register. |
| t_rc | 3:0 | ro | 0xC | Read cycle time, refer to SET_CYCLES register. |

Register (pl353) opmode0_1

| | |
|------------------|------------|
| Name | opmode0_1 |
| Relative Address | 0x00000124 |
| Absolute Address | 0xE000E124 |
| Width | 32 bits |

Access Type ro
 Reset Value 0xE4FE0800
 Description SRAM/NOR chip select 1 OpCode, active

Register opcode0_1 Details

| Field Name | Bits | Type | Reset Value | Description |
|---|-------|------|-------------|---|
| XNANDPS_OPMODE_A DDRESS_MATCH_MASK (OPMODE_ADDRESS_M ATCH) | 31:24 | ro | 0xE4 | see 0x120 |
| XNANDPS_OPMODE_A DDRESS_MASK (OPMODE_ADDRESS) | 23:16 | ro | 0xFE | see 0x120 |
| XNANDPS_OPMODE_B URST_ALIGN_MASK (OPMODE_BURST_ALIG N) | 15:13 | ro | 0x0 | reserved |
| XNANDPS_OPMODE_B LS_MASK (OPMODE_BLS) | 12 | ro | 0x0 | reserved |
| XNANDPS_OPMODE_A DV_MASK (OPMODE_ADV) | 11 | ro | 0x1 | reserved |
| XNANDPS_OPMODE_B AA_MASK (OPMODE_BAA) | 10 | ro | 0x0 | The memory uses the burst address advance signal, baa_n, when set. For a NAND memory interface, this bit is reserved. |
| XNANDPS_OPMODE_W R_BL_MASK (OPMODE_WR_BL) | 9:7 | ro | 0x0 | Selects the write burst lengths, see SET_OPMODE register. |
| XNANDPS_OPMODE_W R_SYNC_MASK (OPMODE_WR_SYNC) | 6 | ro | 0x0 | SRAM/NOR interface operates in asynchronous mode |
| XNANDPS_OPMODE_R D_BL_MASK (OPMODE_RD_BL) | 5:3 | ro | 0x0 | Select memory burst lengths, see SET_OPMODE Register. |
| XNANDPS_OPMODE_R D_SYNC_MASK (OPMODE_RD_SYNC) | 2 | ro | 0x0 | reserved |
| XNANDPS_OPMODE_M W_MASK (OPMODE_MW) | 1:0 | ro | 0x0 | Data bus width (8 or 16), see SET_OPMODE register. |

Register (pl353) XNANDPS_IF1_CHIP_0_CONFIG_OFFSET

| | |
|------------------|----------------------------------|
| Name | XNANDPS_IF1_CHIP_0_CONFIG_OFFSET |
| Software Name | IF1_CHIP_0_CONFIG |
| Relative Address | 0x00000180 |
| Absolute Address | 0xE000E180 |
| Width | 24 bits |
| Access Type | ro |
| Reset Value | 0x0024ABCC |
| Description | NAND Flash timing, active |

Register XNANDPS_IF1_CHIP_0_CONFIG_OFFSET Details

There is an instance of this register for each NAND chip supported. You cannot read the read-only `nand_cycles` Register in the Reset state

| Field Name | Bits | Type | Reset Value | Description |
|------------|-------|------|-------------|--|
| t_rr | 23:20 | ro | 0x2 | BUSY to RE, refer to SET_CYCLES register. |
| t_ar | 19:17 | ro | 0x2 | ID read time, refer to SET_CYCLES register. |
| t_clr | 16:14 | ro | 0x2 | Page cycle time, refer to SET_CYCLES register. Status read time for NAND chip configurations. Minimum permitted value = 0. |
| t_wp | 13:11 | ro | 0x5 | WE deassertion delay, refer to SET_CYCLES register. |
| t_rea | 10:8 | ro | 0x3 | RE assertion delay, refer to SET_CYCLES register. |
| t_wc | 7:4 | ro | 0xC | Write cycle time, refer to SET_CYCLES register. |
| t_rc | 3:0 | ro | 0xC | Read cycle time, refer to SET_CYCLES register. |

Register (pl353) opmode1_0

| | |
|------------------|---------------------------|
| Name | opmode1_0 |
| Relative Address | 0x00000184 |
| Absolute Address | 0xE000E184 |
| Width | 32 bits |
| Access Type | ro |
| Reset Value | 0xE1FF0001 |
| Description | NAND Flash OpCode, active |

Register `opmode1_0` Details

| Field Name | Bits | Type | Reset Value | Description |
|--|-------|------|-------------|---|
| XNANDPS_OPMODE_ADDRESS_MATCH_MASK (OPMODE_ADDRESS_MATCH) | 31:24 | ro | 0xE1 | Return the value of this tie-off. This is the comparison value for address bits [31:24] to determine the chip that is selected. |
| XNANDPS_OPMODE_ADDRESS_MASK (OPMODE_ADDRESS) | 23:16 | ro | 0xFF | Return the value of this tie-off. This is the mask for address bits[31:24] to determine the chip that must be selected. A logic 1 indicates the bit is used for comparison. |
| reserved | 15:13 | ro | 0x0 | Reserved. Do not modify. |
| reserved | 12 | ro | 0x0 | Reserved. Do not modify. |
| reserved | 11 | ro | 0x0 | Reserved. Do not modify. |
| reserved | 10 | ro | 0x0 | Reserved. Do not modify. |
| reserved | 9:7 | ro | 0x0 | Reserved. Do not modify. |
| reserved | 6 | ro | 0x0 | Reserved. Do not modify. |
| reserved | 5:3 | ro | 0x0 | Reserved. Do not modify. |
| reserved | 2 | ro | 0x0 | Reserved. Do not modify. |
| XNANDPS_OPMODE_MW_MASK (OPMODE_MW) | 1:0 | ro | 0x1 | Data bus width is 8 bits, see SET_OPMODE register. |

Register ([pl353](#)) `XNANDPS_USER_STATUS_OFFSET`

| | |
|------------------|----------------------------|
| Name | XNANDPS_USER_STATUS_OFFSET |
| Software Name | USER_STATUS |
| Relative Address | 0x00000200 |
| Absolute Address | 0xE000E200 |
| Width | 8 bits |
| Access Type | ro |
| Reset Value | 0x00000000 |
| Description | User Status Register |

Register `XNANDPS_USER_STATUS_OFFSET` Details

The `user_status` is read-only and returns the value of the `user_status[7:0]` signals. You can read this register in all operating states.

| Field Name | Bits | Type | Reset Value | Description |
|---------------------------------|------|------|-------------|--|
| XNANDPS_USER_STATUS_MASK (MASK) | 7:0 | ro | 0x0 | This value returns the state of the user_status[7:0] inputs. |

Register (pl353) XNANDPS_USER_CONFIG_OFFSET

| | |
|------------------|-----------------------------|
| Name | XNANDPS_USER_CONFIG_OFFSET |
| Software Name | USER_CONFIG |
| Relative Address | 0x00000204 |
| Absolute Address | 0xE000E204 |
| Width | 8 bits |
| Access Type | wo |
| Reset Value | x |
| Description | User Configuration Register |

Register XNANDPS_USER_CONFIG_OFFSET Details

The user_config

is write-only and controls the status of the user_config[7:0] signals. You can write to this register in all operating states.

| Field Name | Bits | Type | Reset Value | Description |
|---------------------------------|------|------|-------------|--|
| XNANDPS_USER_CONFIG_MASK (MASK) | 7:0 | wo | x | This value sets the state of the user_config[7:0] outputs. |

Register (pl353) XNANDPS_IF1_ECC_OFFSET

| | |
|------------------|---------------------------------|
| Name | XNANDPS_IF1_ECC_OFFSET |
| Software Name | IF1_ECC |
| Relative Address | 0x00000400 |
| Absolute Address | 0xE000E400 |
| Width | 30 bits |
| Access Type | ro |
| Reset Value | 0x00000000 |
| Description | ECC Status and Clear Register 1 |

Register XNANDPS_IF1_ECC_OFFSET Details

The ecc_status

is read-only and contains status information for the ECC. Although this is a read-only register, the bottom five bits can be written to clear the corresponding interrupts. To clear the interrupt, you must write a 1 to the appropriate bit.

| Field Name | Bits | Type | Reset Value | Description |
|---|-------|------|-------------|--|
| XNANDPS_ECC_READ_MASK (ECC_READ) | 29:25 | ro | 0x0 | Read flags for ECC blocks. Indicate whether the stored ECC value for each block has been read from memory: 0: not read 1: read Bit [29] Extra block (if used). Bit [28] Block 3. Bit [27] Block 2. Bit [26] Block 1. Bit [25] Block 0. |
| XNANDPS_ECC_CAN_CORRECT_MASK (ECC_CAN_CORRECT) | 24:20 | ro | 0x0 | Correctable flag for each ECC block: 0: not correctable error 1: correctable error Bit [24] Extra block (if used). Bit [23] Block 3. Bit [22] Block 2. Bit [21] Block 1. Bit [20] Block 0. |
| XNANDPS_ECC_FAIL_MASK (ECC_FAIL) | 19:15 | ro | 0x0 | Pass/fail flag for each ECC block |
| XNANDPS_ECC_VALID_MASK (ECC_VALID) | 14:10 | ro | 0x0 | Valid flag for each ECC block. |
| XNANDPS_ECC_READ_NOT_WRITE_MASK (ECC_READ_NOT_WRITE) | 9 | ro | 0x0 | ECC calculation type: 0: write 1: read |
| XNANDPS_ECC_LAST_MASK (ECC_LAST) | 8:7 | ro | 0x0 | Last ECC result is updated after completing the ECC calculation: 00: Completed successfully. 01: Unaligned Address, or out-of-range. 10: Data stop after incomplete block. 11: Data stopped but values not read/written because of ecc_jump value. |

| Field Name | Bits | Type | Reset Value | Description |
|---|------|------|-------------|--|
| XNANDPS_ECC_STATUS_MASK (ECC_STATUS) | 6 | ro | 0x0 | Status of the ECC block: 0: idle 1: busy |
| XNANDPS_ECC_STATUS_RAW_INT_STATUS_MASK (ECC_STATUS_RAW_INT_STATUS) | 5:0 | ro | 0x0 | The interrupts are: Bit [5] Abort. Bit [4] Extra block (if used). Bit [3] Block 3. Bit [2] Block 2. Bit [1] Block 1. Bit [0] Block 0. To clear the interrupt, write a 1 to the bit. |

Register ([pl353](#)) ecc_memcfg_1

| | |
|------------------|-------------------------------------|
| Name | ecc_memcfg_1 |
| Relative Address | 0x00000404 |
| Absolute Address | 0xE000E404 |
| Width | 13 bits |
| Access Type | rw |
| Reset Value | 0x00000043 |
| Description | ECC Memory Configuration Register 1 |

Register ecc_memcfg_1 Details

The ecc_memcfg Register is read-write and contains information about the structure of the memory. Note; You must not write to this register while the ECC block is busy. You can read the current ECC block status from the ECC Status Register.

| Field Name | Bits | Type | Reset Value | Description |
|---|-------|------|-------------|---|
| XNANDPS_ECC_MEMCFG_ECC_EXTRA_BLOCK_SIZE_MASK (ECC_MEMCFG_ECC_EXTRA_BLOCK_SIZE) | 12:11 | rw | 0x0 | The size of the extra block in memory after the last 512 block: 00: 4 bytes 01: 8 bytes 10: 16 bytes 11: 32 bytes Note: These bits are only present if you configure the SMC to use the ECC Extra Block Enable option. |
| XNANDPS_ECC_MEMCFG_ECC_EXTRA_BLOCK_MASK (ECC_MEMCFG_ECC_EXTRA_BLOCK) | 10 | rw | 0x0 | If configured, this enables a small block for extra information after the last 512 bytes block in the page. Note: These bits are only present if the ECC Extra Block Enable option is configured. |

| Field Name | Bits | Type | Reset Value | Description |
|---|------|------|-------------|---|
| XNANDPS_ECC_MEMCFG_ECC_INT_ABORT_MASK (ECC_MEMCFG_ECC_INT_ABORT) | 9 | rw | 0x0 | Interrupt on ECC abort: 0: don't assert 1: assert |
| XNANDPS_ECC_MEMCFG_ECC_INT_PASS_MASK (ECC_MEMCFG_ECC_INT_PASS) | 8 | rw | 0x0 | Interrupt when a correct ECC value is read from memory: 0: don't assert 1: assert |
| XNANDPS_ECC_MEMCFG_IGNORE_ADD8_MASK (ECC_MEMCFG_IGNORE_ADD8) | 7 | rw | 0x0 | Use to indicate if A8 is output with the address, required to find the aligned start of blocks: 0: A8 is output 1: A8 is not output |
| XNANDPS_ECC_MEMCFG_ECC_JUMP_MASK (ECC_MEMCFG_ECC_JUMP) | 6:5 | rw | 0x2 | Indicate that the memory supports column change address commands: 00: no jumping, reads and writes only occur at end of page 01: jump using column change commands 10: jump using full command 11: reserved |
| XNANDPS_ECC_MEMCFG_ECC_READ_END_MASK (ECC_MEMCFG_ECC_READ_END) | 4 | rw | 0x0 | Indicate when ECC values are read from memory: 0: ECC value for a block must be read immediately after the block. Data access must stop on a 512 byte boundary. 1: ECC values for all blocks are read at the end of the page. |
| XNANDPS_ECC_MEMCFG_ECC_MODE_MASK (ECC_MEMCFG_ECC_MODE) | 3:2 | rw | 0x0 | Specify the mode of the ECC block: 00: bypassed 01: ECC values are calculated and made available on the APB interface. But they are not read to or written from memory. 10: ECC values and calculated and read/written to memory. For a read, the ECC value is checked and the result of the check is made available on the APB interface. 11: reserved |
| XNANDPS_ECC_MEMCFG_PAGE_SIZE_MASK (ECC_MEMCFG_PAGE_SIZE) | 1:0 | rw | 0x3 | The number of 512 byte blocks in a page: 00: No 512 byte blocks. Reserved if an ecc_extra_block is not configured and enabled. 01: One 512 byte block. 10: Two 512 byte blocks. 11: Four 512 byte blocks. |

Register ([pl353](#)) ecc_memcommand1_1

Name ecc_memcommand1_1

| | |
|------------------|---------------------------------|
| Relative Address | 0x00000408 |
| Absolute Address | 0xE000E408 |
| Width | 25 bits |
| Access Type | rw |
| Reset Value | 0x01300080 |
| Description | ECC Memory Command 1 Register 1 |

Register `ecc_memcommand1_1` Details

The `ecc_memcommand1`

is read-write and contains the commands that the ECC block uses to detect the start of an ECC operation.

| Field Name | Bits | Type | Reset Value | Description |
|---|-------|------|-------------|--|
| XNANDPS_ECC_MEMCOMMAND1_RD_CMD_END_VALID_MASK (ECC_MEMCOMMAND1_RD_CMD_END_VALID) | 24 | rw | 0x1 | Use the end command |
| XNANDPS_ECC_MEMCOMMAND1_RD_CMD_END_MASK (ECC_MEMCOMMAND1_RD_CMD_END) | 23:16 | rw | 0x30 | Use the NAND command to initiate a write (0x30). |
| XNANDPS_ECC_MEMCOMMAND1_RD_CMD_MASK (ECC_MEMCOMMAND1_RD_CMD) | 15:8 | rw | 0x0 | Use the NAND command used to initiate a read (0x00). |
| XNANDPS_ECC_MEMCOMMAND1_WR_CMD_MASK (ECC_MEMCOMMAND1_WR_CMD) | 7:0 | rw | 0x80 | Use the NAND command to initiate a write (0x80). |

Register ([p1353](#)) `ecc_memcommand2_1`

| | |
|------------------|---------------------------------|
| Name | <code>ecc_memcommand2_1</code> |
| Relative Address | 0x0000040C |
| Absolute Address | 0xE000E40C |
| Width | 25 bits |
| Access Type | rw |
| Reset Value | 0x01E00585 |
| Description | ECC Memory Command 2 Register 1 |

Register ecc_memcommand2_1 Details

The ecc_memcommand2 Register is read-write and contains the commands that the ECC block uses to access different parts of a NAND page. The reset value is suitable for ONFI 1.0 compliant devices

| Field Name | Bits | Type | Reset Value | Description |
|---|-------|------|-------------|--|
| XNANDPS_ECC_MEMCOMMAND2_RD_COL_CHANGE_END_VALID_MASK (ECC_MEMCOMMAND2_RD_COL_CHANGE_END_VALID) | 24 | rw | 0x1 | Use the end command |
| XNANDPS_ECC_MEMCOMMAND2_RD_COL_CHANGE_END_MASK (ECC_MEMCOMMAND2_RD_COL_CHANGE_END) | 23:16 | rw | 0xE0 | Use the NAND command to initiate a write. |
| XNANDPS_ECC_MEMCOMMAND2_RD_COL_CHANGE_MASK (ECC_MEMCOMMAND2_RD_COL_CHANGE) | 15:8 | rw | 0x5 | Use the NAND command to initiate a read or Spare bits pointer command. |
| XNANDPS_ECC_MEMCOMMAND2_WR_COL_CHANGE_MASK (ECC_MEMCOMMAND2_WR_COL_CHANGE) | 7:0 | rw | 0x85 | The NAND command used to initiate a write |

Register ([pl353](#)) ecc_addr0_1

| | |
|------------------|--------------------------|
| Name | ecc_addr0_1 |
| Relative Address | 0x00000410 |
| Absolute Address | 0xE000E410 |
| Width | 32 bits |
| Access Type | ro |
| Reset Value | 0x00000000 |
| Description | ECC Address 0 Register 1 |

Register ecc_addr0_1 Details

The ecc_addr0 Register is read-only and contains the lower 32 bits of the ECC address

| Field Name | Bits | Type | Reset Value | Description |
|------------|------|------|-------------|----------------------|
| ecc_addr | 31:0 | ro | 0x0 | Address bits 31 to 0 |

Register (pl353) ecc_addr1_1

| | |
|------------------|--------------------------|
| Name | ecc_addr1_1 |
| Relative Address | 0x00000414 |
| Absolute Address | 0xE000E414 |
| Width | 24 bits |
| Access Type | ro |
| Reset Value | 0x00000000 |
| Description | ECC Address 1 Register 1 |

Register ecc_addr1_1 Details

The ecc_addr1 Register is read-only and contains the upper 24 bits of the ECC address.

| Field Name | Bits | Type | Reset Value | Description |
|------------|------|------|-------------|-----------------------|
| ecc_addr | 23:0 | ro | 0x0 | Address bits 55 to 32 |

Register (pl353) ecc_value0_1

| | |
|------------------|------------------------|
| Name | ecc_value0_1 |
| Relative Address | 0x00000418 |
| Absolute Address | 0xE000E418 |
| Width | 32 bits |
| Access Type | ro |
| Reset Value | 0x00000000 |
| Description | ECC Value 0 Register 1 |

Register ecc_value0_1 Details

The five ecc_value Registers are read-only and contain block information for the ECC. Note: Writing any value to an ecc_value Register clears the ecc_int bit.

| Field Name | Bits | Type | Reset Value | Description |
|---|------|------|-------------|---|
| XNANDPS_ECC_VALUE_INT_MASK (ECC_VALUE_INT) | 31 | ro | 0x0 | Interrupt flag for this value |
| XNANDPS_ECC_VALUE_VALID_MASK (ECC_VALUE_VALID) | 30 | ro | 0x0 | Indicate if this value is valid |
| XNANDPS_ECC_VALUE_READ_MASK (ECC_VALUE_READ) | 29 | ro | 0x0 | Indicate if the ECC value has been read from memory |

| Field Name | Bits | Type | Reset Value | Description |
|---|-------|------|-------------|---|
| XNANDPS_ECC_VALUE_FAIL_MASK (ECC_VALUE_FAIL) | 28 | ro | 0x0 | Indicate if this value has failed |
| XNANDPS_ECC_VALUE_CORRECT_MASK (ECC_VALUE_CORRECT) | 27 | ro | 0x0 | Indicate if this block is correctable |
| reserved | 26:24 | ro | 0x0 | Reserved, read undefined |
| XNANDPS_ECC_VALUE_MASK (ECC_VALUE) | 23:0 | ro | 0x0 | ECC value of check result for block, depending on ECC configuration |

Register ([pl353](#)) ecc_value1_1

| | |
|------------------|------------------------|
| Name | ecc_value1_1 |
| Relative Address | 0x0000041C |
| Absolute Address | 0xE000E41C |
| Width | 32 bits |
| Access Type | ro |
| Reset Value | 0x00000000 |
| Description | ECC Value 1 Register 1 |

Register ecc_value1_1 Details

The five ecc_value Registers are read-only and contain block information for the ECC. Note: writing any value to an ecc_value Register clears the ecc_int bit.

| Field Name | Bits | Type | Reset Value | Description |
|---|------|------|-------------|---|
| XNANDPS_ECC_VALUE_INT_MASK (ECC_VALUE_INT) | 31 | ro | 0x0 | Interrupt flag for this value |
| XNANDPS_ECC_VALUE_VALID_MASK (ECC_VALUE_VALID) | 30 | ro | 0x0 | Indicate if this value is valid |
| XNANDPS_ECC_VALUE_READ_MASK (ECC_VALUE_READ) | 29 | ro | 0x0 | Indicate if the ECC value has been read from memory |
| XNANDPS_ECC_VALUE_FAIL_MASK (ECC_VALUE_FAIL) | 28 | ro | 0x0 | Indicate if this value has failed |
| XNANDPS_ECC_VALUE_CORRECT_MASK (ECC_VALUE_CORRECT) | 27 | ro | 0x0 | Indicate if this block is correctable |

| Field Name | Bits | Type | Reset Value | Description |
|---------------------------------------|-------|------|-------------|---|
| reserved | 26:24 | ro | 0x0 | Reserved, read undefined |
| XNANDPS_ECC_VALUE_MASK (ECC_VALUE) | 23:0 | ro | 0x0 | ECC value of check result for block, depending on ECC configuration |

Register ([pl353](#)) ecc_value2_1

| | |
|------------------|------------------------|
| Name | ecc_value2_1 |
| Relative Address | 0x00000420 |
| Absolute Address | 0xE000E420 |
| Width | 32 bits |
| Access Type | ro |
| Reset Value | 0x00000000 |
| Description | ECC Value 2 Register 1 |

Register ecc_value2_1 Details

The five ecc_value Registers are read-only and contain block information for the ECC.

Note: writing any value to an ecc_value Register clears the ecc_int bit.

| Field Name | Bits | Type | Reset Value | Description |
|---|-------|------|-------------|---|
| XNANDPS_ECC_VALUE_INT_MASK (ECC_VALUE_INT) | 31 | ro | 0x0 | Interrupt flag for this value |
| XNANDPS_ECC_VALUE_VALID_MASK (ECC_VALUE_VALID) | 30 | ro | 0x0 | Indicate if this value is valid |
| XNANDPS_ECC_VALUE_READ_MASK (ECC_VALUE_READ) | 29 | ro | 0x0 | Indicate if the ECC value has been read from memory |
| XNANDPS_ECC_VALUE_FAIL_MASK (ECC_VALUE_FAIL) | 28 | ro | 0x0 | Indicate if this value has failed |
| XNANDPS_ECC_VALUE_CORRECT_MASK (ECC_VALUE_CORRECT) | 27 | ro | 0x0 | Indicate if this block is correctable |
| reserved | 26:24 | ro | 0x0 | Reserved, read undefined |
| XNANDPS_ECC_VALUE_MASK (ECC_VALUE) | 23:0 | ro | 0x0 | ECC value of check result for block, depending on ECC configuration |

Register ([pl353](#)) ecc_value3_1

| | |
|------------------|------------------------|
| Name | ecc_value3_1 |
| Relative Address | 0x00000424 |
| Absolute Address | 0xE000E424 |
| Width | 32 bits |
| Access Type | ro |
| Reset Value | 0x00000000 |
| Description | ECC Value 3 Register 1 |

Register ecc_value3_1 Details

The five ecc_value Registers are read-only and contain block information for the ECC. Note: writing any value to an ecc_value Register clears the ecc_int bit.

| Field Name | Bits | Type | Reset Value | Description |
|---|-------|------|-------------|---|
| XNANDPS_ECC_VALUE_INT_MASK (ECC_VALUE_INT) | 31 | ro | 0x0 | Interrupt flag for this value |
| XNANDPS_ECC_VALUE_VALID_MASK (ECC_VALUE_VALID) | 30 | ro | 0x0 | Indicate if this value is valid |
| XNANDPS_ECC_VALUE_READ_MASK (ECC_VALUE_READ) | 29 | ro | 0x0 | Indicate if the ECC value has been read from memory |
| XNANDPS_ECC_VALUE_FAIL_MASK (ECC_VALUE_FAIL) | 28 | ro | 0x0 | Indicate if this value has failed |
| XNANDPS_ECC_VALUE_CORRECT_MASK (ECC_VALUE_CORRECT) | 27 | ro | 0x0 | Indicate if this block is correctable |
| reserved | 26:24 | ro | 0x0 | Reserved, read undefined |
| XNANDPS_ECC_VALUE_MASK (ECC_VALUE) | 23:0 | ro | 0x0 | ECC value of check result for block, depending on ECC configuration |

B.30 SPI Controller (SPI)

| | |
|---------------|------------------------------------|
| Module Name | SPI Controller (SPI) |
| Software Name | XSPIPS |
| Base Address | 0xE0006000 spi0 0xE0007000 spi1 |
| Description | Serial Peripheral Interface |
| Vendor Info | Cadence SPI |

Register Summary

| Register Name | Address | Width | Type | Reset Value | Description |
|------------------------------------|------------|-------|-------|-------------|------------------------|
| XSPIPS_CR_OFFSET | 0x00000000 | 32 | mixed | 0x00020000 | SPI Configuration. |
| XSPIPS_SR_OFFSET | 0x00000004 | 32 | mixed | 0x00000004 | SPI Interrupt Status |
| XSPIPS_IER_OFFSET | 0x00000008 | 32 | mixed | 0x00000000 | Interrupt Enable. |
| XSPIPS_IDR_OFFSET | 0x0000000C | 32 | mixed | 0x00000000 | Interrupt disable. |
| XSPIPS_IMR_OFFSET | 0x00000010 | 32 | ro | 0x00000000 | Interrupt mask. |
| XSPIPS_ER_OFFSET | 0x00000014 | 32 | mixed | 0x00000000 | SPI Controller Enable. |
| XSPIPS_DR_OFFSET | 0x00000018 | 32 | rw | 0x00000000 | Delay Control |
| XSPIPS_TXD_OFFSET | 0x0000001C | 32 | wo | 0x00000000 | Transmit Data. |
| XSPIPS_RXD_OFFSET | 0x00000020 | 32 | ro | 0x00000000 | Receive Data. |
| XSPIPS_SICR_OFFSET | 0x00000024 | 32 | mixed | 0x000000FF | Slave Idle Count. |
| XSPIPS_TXWR_OFFSET | 0x00000028 | 32 | rw | 0x00000001 | TX_FIFO Threshold. |
| RX_thres_reg0 | 0x0000002C | 32 | rw | 0x00000001 | RX FIFO Threshold. |
| Mod_id_reg0 | 0x000000FC | 32 | ro | 0x00090106 | Module ID. |

Register (SPI) XSPIPS_CR_OFFSET

| | |
|------------------|--------------------------------------|
| Name | XSPIPS_CR_OFFSET |
| Software Name | CR |
| Relative Address | 0x00000000 |
| Absolute Address | spi0: 0xE0006000 spi1: 0xE0007000 |
| Width | 32 bits |
| Access Type | mixed |
| Reset Value | 0x00020000 |
| Description | SPI Configuration. |

Register XSPIPS_CR_OFFSET Details

| Field Name | Bits | Type | Reset Value | Description |
|-------------------------------------|-------|------|-------------|--|
| reserved | 31:18 | ro | 0x0 | Reserved, read as zero, ignored on write. |
| Modefail_gen_en | 17 | rw | 0x1 | ModeFail Generation Enable 1: enable 0: disable |
| XSPIPS_CR_MANSTRT_MASK (MANSTRT) | 16 | wo | 0x0 | Manual Start Command 1: start transmission of data 0: don't care |
| Man_start_en | 15 | rw | 0x0 | Manual Start Enable 1: enables manual start 0: auto mode |
| Manual_CS | 14 | rw | 0x0 | Manual CS 1: manual CS mode 0: auto mode |
| CS | 13:10 | rw | 0x0 | Peripheral chip select lines: xxx0 - slave 0 selected xx01 - slave 1 selected x010 - slave 2 selected 0111 - reserved 1111 - No slave selected |
| PERI_SEL | 9 | rw | 0x0 | Peripheral select decode 1: allow external 3-to-8 decode 0: only 1 of 3 selects |
| REF_CLK | 8 | rw | 0x0 | Master reference clock select 1: not supported 0: use SPI REFERENCE CLOCK |
| reserved | 7:6 | rw | 0x0 | Reserved, read as zero, write with 00 |
| BAUD_RATE_DIV | 5:3 | rw | 0x0 | Master mode baud rate divisor controls the amount the spi_ref_clk is divided inside the SPI block 000: not supported 001: divide by 4 010: divide by 8 011: divide by 16 100: divide by 32 101: divide by 64 110: divide by 128 111: divide by 256 |
| XSPIPS_CR_CPHA_MASK (CPHA) | 2 | rw | 0x0 | Clock phase 1: the SPI clock is inactive outside the word 0: the SPI clock is active outside the word |

| Field Name | Bits | Type | Reset Value | Description |
|-----------------------------------|------|------|-------------|--|
| XSPIPS_CR_CPOL_MASK (CPOL) | 1 | rw | 0x0 | Clock polarity outside SPI word 1: the SPI clock is quiescent high 0: the SPI clock is quiescent low |
| XSPIPS_CR_MSTREN_MASK (MSTREN) | 0 | rw | 0x0 | Mode select 1: the SPI is in master mode 0: the SPI is in slave mode |

Register (SPI) XSPIPS_SR_OFFSET

| | |
|------------------|--------------------------------------|
| Name | XSPIPS_SR_OFFSET |
| Software Name | SR |
| Relative Address | 0x00000004 |
| Absolute Address | spi0: 0xE0006004 spi1: 0xE0007004 |
| Width | 32 bits |
| Access Type | mixed |
| Reset Value | 0x00000004 |
| Description | SPI Interrupt Status |

Register XSPIPS_SR_OFFSET Details

This register is set when the described event occurs and the interrupt is enabled in the mask register. When any of these bits are set the interrupt output is asserted high, but may be masked by Intrpt_Mask_reg0 before generating the IRQ interrupt.

Bit writes:

Write 1: clear individual bit.

Write 0: ignored.

Read: see bit descriptions.

| Field Name | Bits | Type | Reset Value | Description |
|--|------|------|-------------|--|
| reserved | 31:7 | ro | 0x0 | Reserved, read as zero, ignored on write. |
| XSPIPS_IXR_TXUF_MASK (IXR_TXUF) | 6 | wtc | 0x0 | TX FIFO underflow, write one to this bit location to clear. 1: underflow is detected 0: no underflow has been detected |
| XSPIPS_IXR_RXFULL_MASK (IXR_RXFULL) | 5 | wtc | 0x0 | RX FIFO full 1: FIFO is full 0: FIFO is not full |

| Field Name | Bits | Type | Reset Value | Description |
|--|------|------|-------------|---|
| XSPIPS_IXR_RXNEMPTY_MASK (IXR_RXNEMPTY) | 4 | wtc | 0x0 | RX FIFO not empty 1: FIFO has more than or equal to THRESHOLD entries 0: FIFO has less than RX THRESHOLD entries |
| XSPIPS_IXR_TXFULL_MASK (IXR_TXFULL) | 3 | wtc | 0x0 | TX FIFO full 1: FIFO is full 0: FIFO is not full |
| XSPIPS_IXR_TXOW_MASK (IXR_TXOW) | 2 | wtc | 0x1 | TX FIFO not full 1: FIFO has less than THRESHOLD entries 0: FIFO has more than or equal to THRESHOLD entries |
| XSPIPS_IXR_MODF_MASK (IXR_MODF) | 1 | wtc | 0x0 | Indicates the voltage on pin n _{ss} _{in} is inconsistent with the SPI mode. Set =1 if n _{ss} _{in} is low in master mode (multi-master contention) or n _{ss} _{in} goes high during a transmission in slave mode. These conditions will clear the spi_enable bit and disable the SPI. This bit is reset only by a system reset and cleared only when this register is read. ModeFail interrupt, write one to this bit location to clear. 1: a mode fault has occurred 0: no mode fault has been detected |
| XSPIPS_IXR_RXOVR_MASK (IXR_RXOVR) | 0 | wtc | 0x0 | Receive Overflow interrupt, write one to this bit location to clear. 1: overflow occurred 0: no overflow occurred |

Register (SPI) XSPIPS_IER_OFFSET

| | |
|------------------|--------------------------------------|
| Name | XSPIPS_IER_OFFSET |
| Software Name | IER |
| Relative Address | 0x00000008 |
| Absolute Address | spi0: 0xE0006008 spi1: 0xE0007008 |
| Width | 32 bits |
| Access Type | mixed |
| Reset Value | 0x00000000 |
| Description | Interrupt Enable. |

Register XSPIPS_IER_OFFSET Details

| Field Name | Bits | Type | Reset Value | Description |
|--|------|------|-------------|--|
| reserved | 31:7 | ro | 0x0 | Reserved, read as zero, ignored on write. |
| XSPIPS_IXR_TXUF_MASK (IXR_TXUF) | 6 | wo | 0x0 | TX FIFO underflow enable 1: enable the interrupt 0: no effect |
| XSPIPS_IXR_RXFULL_MASK (IXR_RXFULL) | 5 | wo | 0x0 | RX FIFO full enable 1: enable the interrupt 0: no effect |
| XSPIPS_IXR_RXNEMPTY_MASK (IXR_RXNEMPTY) | 4 | wo | 0x0 | RX FIFO not empty enable 1: enable the interrupt 0: no effect |
| XSPIPS_IXR_TXFULL_MASK (IXR_TXFULL) | 3 | wo | 0x0 | TX FIFO full enable 1: enable the interrupt 0: no effect |
| XSPIPS_IXR_TXOW_MASK (IXR_TXOW) | 2 | wo | 0x0 | TX FIFO not full enable 1: enable the interrupt 0: no effect |
| XSPIPS_IXR_MODF_MASK (IXR_MODF) | 1 | wo | 0x0 | ModeFail interrupt enable 1: enable the interrupt 0: no effect |
| XSPIPS_IXR_RXOVR_MASK (IXR_RXOVR) | 0 | wo | 0x0 | Receive Overflow interrupt enable 1: enable the interrupt 0: no effect |

Register (SPI) XSPIPS_IDR_OFFSET

| | |
|------------------|--------------------------------------|
| Name | XSPIPS_IDR_OFFSET |
| Software Name | IDR |
| Relative Address | 0x0000000C |
| Absolute Address | spi0: 0xE000600C spi1: 0xE000700C |
| Width | 32 bits |
| Access Type | mixed |
| Reset Value | 0x00000000 |
| Description | Interrupt disable. |

Register XSPIPS_IDR_OFFSET Details

| Field Name | Bits | Type | Reset Value | Description |
|--|------|------|-------------|--|
| reserved | 31:7 | ro | 0x0 | Reserved, read as zero, ignored on write. |
| XSPIPS_IXR_TXUF_MASK (IXR_TXUF) | 6 | wo | 0x0 | TX FIFO underflow enable 1: disables the interrupt 0: no effect |
| XSPIPS_IXR_RXFULL_MASK (IXR_RXFULL) | 5 | wo | 0x0 | RX FIFO full enable 1: disables the interrupt 0: no effect |
| XSPIPS_IXR_RXNEMPTY_MASK (IXR_RXNEMPTY) | 4 | wo | 0x0 | RX FIFO not empty enable 1: disables the interrupt 0: no effect |
| XSPIPS_IXR_TXFULL_MASK (IXR_TXFULL) | 3 | wo | 0x0 | TX FIFO full enable 1: disables the interrupt 0: no effect |
| XSPIPS_IXR_TXOW_MASK (IXR_TXOW) | 2 | wo | 0x0 | TX FIFO not full enable 1: disables the interrupt 0: no effect |
| XSPIPS_IXR_MODF_MASK (IXR_MODF) | 1 | wo | 0x0 | ModeFail interrupt enable 1: disables the interrupt 0: no effect |
| XSPIPS_IXR_RXOVR_MASK (IXR_RXOVR) | 0 | wo | 0x0 | Receive Overflow interrupt enable 1: disables the interrupt 0: no effect |

Register (SPI) XSPIPS_IMR_OFFSET

| | |
|------------------|--------------------------------------|
| Name | XSPIPS_IMR_OFFSET |
| Software Name | IMR |
| Relative Address | 0x00000010 |
| Absolute Address | spi0: 0xE0006010 spi1: 0xE0007010 |
| Width | 32 bits |
| Access Type | ro |
| Reset Value | 0x00000000 |
| Description | Interrupt mask. |

Register XSPIPS_IMR_OFFSET Details

| Field Name | Bits | Type | Reset Value | Description |
|--|------|------|-------------|--|
| reserved | 31:7 | ro | 0x0 | Reserved, read as zero, ignored on write. |
| XSPIPS_IXR_TXUF_MASK (IXR_TXUF) | 6 | ro | 0x0 | TX FIFO underflow enable 1: interrupt is disabled 0: interrupt is enabled |
| XSPIPS_IXR_RXFULL_MASK (IXR_RXFULL) | 5 | ro | 0x0 | RX FIFO full enable 1: interrupt is disabled 0: interrupt is enabled |
| XSPIPS_IXR_RXNEMPTY_MASK (IXR_RXNEMPTY) | 4 | ro | 0x0 | RX FIFO not empty enable 1: interrupt is disabled 0: interrupt is enabled |
| XSPIPS_IXR_TXFULL_MASK (IXR_TXFULL) | 3 | ro | 0x0 | TX FIFO full enable 1: interrupt is disabled 0: interrupt is enabled |
| XSPIPS_IXR_TXOW_MASK (IXR_TXOW) | 2 | ro | 0x0 | TX FIFO not full enable 1: interrupt is disabled 0: interrupt is enabled |
| XSPIPS_IXR_MODF_MASK (IXR_MODF) | 1 | ro | 0x0 | ModeFail interrupt enable 1: interrupt is disabled 0: interrupt is enabled |
| XSPIPS_IXR_RXOVR_MASK (IXR_RXOVR) | 0 | ro | 0x0 | Receive Overflow interrupt enable 1: interrupt is disabled 0: interrupt is enabled |

Register (SPI) XSPIPS_ER_OFFSET

| | |
|------------------|--------------------------------------|
| Name | XSPIPS_ER_OFFSET |
| Software Name | ER |
| Relative Address | 0x00000014 |
| Absolute Address | spi0: 0xE0006014 spi1: 0xE0007014 |
| Width | 32 bits |
| Access Type | mixed |
| Reset Value | 0x00000000 |
| Description | SPI Controller Enable. |

Register XSPIPS_ER_OFFSET Details

| Field Name | Bits | Type | Reset Value | Description |
|--------------------------------|------|------|-------------|---|
| reserved | 31:1 | ro | 0x0 | Reserved, read as zero, ignored on write. |
| XSPIPS_ER_ENABLE_MASK (ENABLE) | 0 | rw | 0x0 | SPI_Enable 1: enable the SPI 0: disable the SPI |

Register (SPI) XSPIPS_DR_OFFSET

| | |
|------------------|--------------------------------------|
| Name | XSPIPS_DR_OFFSET |
| Software Name | DR |
| Relative Address | 0x00000018 |
| Absolute Address | spi0: 0xE0006018 spi1: 0xE0007018 |
| Width | 32 bits |
| Access Type | rw |
| Reset Value | 0x00000000 |
| Description | Delay Control |

Register XSPIPS_DR_OFFSET Details

| Field Name | Bits | Type | Reset Value | Description |
|------------------------------|-------|------|-------------|---|
| d_nss | 31:24 | rw | 0x0 | Delay in SPI REFERENCE CLOCK or ext_clk cycles for the length that the master mode chip select outputs are de-asserted between words when cpha=0. |
| XSPIPS_DR_BTWN_MASK (BTWN) | 23:16 | rw | 0x0 | Delay in SPI REFERENCE CLOCK or ext_clk cycles between one chip select being de-activated and the activation of another |
| XSPIPS_DR_AFTER_MASK (AFTER) | 15:8 | rw | 0x0 | Delay in SPI REFERENCE CLOCK or ext_clk cycles between last bit of current word and the first bit of the next word. |
| XSPIPS_DR_INIT_MASK (INIT) | 7:0 | rw | 0x0 | Added delay in SPI REFERENCE CLOCK or ext_clk cycles between setting n_ss_out low and first bit transfer. |

Register (SPI) XSPIPS_TXD_OFFSET

| | |
|---------------|-------------------|
| Name | XSPIPS_TXD_OFFSET |
| Software Name | TXD |

Relative Address 0x0000001C
 Absolute Address spi0: 0xE000601C
 spi1: 0xE000701C
 Width 32 bits
 Access Type wo
 Reset Value 0x00000000
 Description Transmit Data.

Register XSPIPS_TXD_OFFSET Details

| Field Name | Bits | Type | Reset Value | Description |
|--------------|------|------|-------------|---|
| TX_FIFO_data | 31:0 | wo | 0x0 | Data to TX FIFO. Valid data bits are [7:0]. |

Register (SPI) XSPIPS_RXD_OFFSET

Name XSPIPS_RXD_OFFSET
 Software Name RXD
 Relative Address 0x00000020
 Absolute Address spi0: 0xE0006020
 spi1: 0xE0007020
 Width 32 bits
 Access Type ro
 Reset Value 0x00000000
 Description Receive Data.

Register XSPIPS_RXD_OFFSET Details

| Field Name | Bits | Type | Reset Value | Description |
|--------------|------|------|-------------|---|
| RX_FIFO_data | 31:0 | ro | 0x0 | Data from RX FIFO. Valid data bits are [7:0]. |

Register (SPI) XSPIPS_SICR_OFFSET

Name XSPIPS_SICR_OFFSET
 Software Name SICR
 Relative Address 0x00000024
 Absolute Address spi0: 0xE0006024
 spi1: 0xE0007024
 Width 32 bits
 Access Type mixed

Reset Value 0x000000FF
 Description Slave Idle Count.

Register XSPIPS_SICR_OFFSET Details

| Field Name | Bits | Type | Reset Value | Description |
|-----------------|------|------|-------------|---|
| reserved | 31:8 | ro | 0x0 | Reserved, read as zero, ignored on write. |
| Slave_Idle_coun | 7:0 | rw | 0xFF | SPI in slave mode detects a start only when the external SPI master serial clock (sclk_in) is stable (quiescent state) for SPI REFERENCE CLOCK cycles specified by slave idle count register or when the SPI is deselected. |

Register (SPI) XSPIPS_TXWR_OFFSET

Name XSPIPS_TXWR_OFFSET
 Software Name TXWR
 Relative Address 0x00000028
 Absolute Address spi0: 0xE0006028
 spi1: 0xE0007028
 Width 32 bits
 Access Type rw
 Reset Value 0x00000001
 Description TX_FIFO Threshold.

Register XSPIPS_TXWR_OFFSET Details

| Field Name | Bits | Type | Reset Value | Description |
|----------------------|------|------|-------------|--|
| Threshold_of_TX_FIFO | 31:0 | rw | 0x1 | Defines the level at which the TX FIFO not full interrupt is generated |

Register (SPI) RX_thres_reg0

Name RX_thres_reg0
 Relative Address 0x0000002C
 Absolute Address spi0: 0xE000602C
 spi1: 0xE000702C
 Width 32 bits
 Access Type rw
 Reset Value 0x00000001

Description RX FIFO Threshold.

Register RX_thres_reg0 Details

| Field Name | Bits | Type | Reset Value | Description |
|----------------------|------|------|-------------|---|
| Threshold_of_RX_FIFO | 31:0 | rw | 0x1 | Defines the level at which the RX FIFO not empty interrupt is generated |

Register (SPI) Mod_id_reg0

Name Mod_id_reg0
 Relative Address 0x000000FC
 Absolute Address spi0: 0xE00060FC
 spi1: 0xE00070FC
 Width 32 bits
 Access Type ro
 Reset Value 0x00090106
 Description Module ID.

Register Mod_id_reg0 Details

| Field Name | Bits | Type | Reset Value | Description |
|------------|-------|------|-------------|---|
| reserved | 31:25 | ro | 0x0 | Reserved, read as zero, ignored on write. |
| module_ID | 24:0 | ro | 0x90106 | Module ID number |

B.31 System Watchdog Timer (swdt)

Module Name System Watchdog Timer (swdt)
 Software Name XWDTPS
 Base Address 0xF8005000 swdt
 Description System Watchdog Timer Registers
 Vendor Info

Register Summary

| Register Name | Address | Width | Type | Reset Value | Description |
|--|------------|-------|-------|-------------|--|
| XWDTPS_ZMR_OFFSET | 0x00000000 | 24 | mixed | 0x000001C0 | WD zero mode register |
| XWDTPS_CCR_OFFSET | 0x00000004 | 26 | mixed | 0x00003FFC | Counter Control Register |
| XWDTPS_RESTART_OFF SET | 0x00000008 | 16 | wo | 0x00000000 | Restart key register - this not a real register as no data is stored |
| XWDTPS_SR_OFFSET | 0x0000000C | 1 | ro | 0x00000000 | Status Register |

Register ([swdt](#)) XWDTPS_ZMR_OFFSET

Name XWDTPS_ZMR_OFFSET
 Software Name ZMR
 Relative Address 0x00000000
 Absolute Address 0xF8005000
 Width 24 bits
 Access Type mixed
 Reset Value 0x000001C0
 Description WD zero mode register

Register XWDTPS_ZMR_OFFSET Details

| Field Name | Bits | Type | Reset Value | Description |
|------------------------------|-------|------|-------------|--|
| XWDTPS_ZMR_ZKEY_M ASK (ZKEY) | 23:12 | wo | 0x0 | Zero access key - writes to the zero mode register are only valid if this field is set to 0xABC; this field is write only. |
| reserved | 11:9 | waz | 0x0 | Should be zero (sbz) |

| Field Name | Bits | Type | Reset Value | Description |
|-------------------------------|------|------|-------------|--|
| XWDTPS_ZMR_IRQLN_MASK (IRQLN) | 8:7 | rw | 0x3 | Interrupt request length - selects the number of pclk cycles during which an interrupt request is held active after it is invoked: 00 = 4 01 = 8 10 = 16 11 = 32 |
| reserved | 6:4 | rw | 0x4 | Reserved, set to 0x4. |
| reserved | 3 | waz | 0x0 | Should be zero (sbz) |
| XWDTPS_ZMR_IRQEN_MASK (IRQEN) | 2 | rw | 0x0 | Interrupt request enable - if set, the watchdog will issue an interrupt request when the counter reaches zero, if WDEN = 1. |
| XWDTPS_ZMR_RSTEN_MASK (RSTEN) | 1 | rw | 0x0 | Reset enable - if set, the watchdog will issue an internal reset when the counter reaches zero, if WDEN = 1. |
| XWDTPS_ZMR_WDEN_MASK (WDEN) | 0 | rw | 0x0 | Watchdog enable - if set, the watchdog is enabled and can generate any signals that are enabled. |

Register ([swdt](#)) XWDTPS_CCR_OFFSET

| | |
|------------------|--------------------------|
| Name | XWDTPS_CCR_OFFSET |
| Software Name | CCR |
| Relative Address | 0x00000004 |
| Absolute Address | 0xF8005004 |
| Width | 26 bits |
| Access Type | mixed |
| Reset Value | 0x00003FFC |
| Description | Counter Control Register |

Register XWDTPS_CCR_OFFSET Details

| Field Name | Bits | Type | Reset Value | Description |
|-----------------------------|-------|------|-------------|---|
| XWDTPS_CCR_CKEY_MASK (CKEY) | 25:14 | wo | 0x0 | Counter access key - writes to the control register are only valid if this field is set to 0x248; this field is write only. |

| Field Name | Bits | Type | Reset Value | Description |
|---------------------------------|------|------|-------------|--|
| XWDTPS_CCR_CRV_MASK (CRV) | 13:2 | rw | 0xFFF | Counter restart value - the counter is restarted with the value 0xNNNFFF, where NNN is the value of this field. |
| XWDTPS_CCR_CLKSEL_MASK (CLKSEL) | 1:0 | rw | 0x0 | Counter clock prescale - selects the prescaler division ratio: 00 = pclk divided by 8 01 = pclk divided by 64 10 = pclk divided by 512 11 = pclk divided by 4096 Note: If a restart signal is received the prescaler should be reset. |

Register ([swdt](#)) XWDTPS_RESTART_OFFSET

| | |
|------------------|--|
| Name | XWDTPS_RESTART_OFFSET |
| Software Name | RESTART |
| Relative Address | 0x00000008 |
| Absolute Address | 0xF8005008 |
| Width | 16 bits |
| Access Type | wo |
| Reset Value | 0x00000000 |
| Description | Restart key register - this not a real register as no data is stored |

Register XWDTPS_RESTART_OFFSET Details

| Field Name | Bits | Type | Reset Value | Description |
|----------------------------------|------|------|-------------|--|
| XWDTPS_RESTART_KEY_VAL (KEY_VAL) | 15:0 | wo | 0x0 | Restart key - the watchdog is restarted if this field is set to the value 0x1999 |

Register ([swdt](#)) XWDTPS_SR_OFFSET

| | |
|------------------|------------------|
| Name | XWDTPS_SR_OFFSET |
| Software Name | SR |
| Relative Address | 0x0000000C |
| Absolute Address | 0xF800500C |
| Width | 1 bits |
| Access Type | ro |
| Reset Value | 0x00000000 |
| Description | Status Register |

Register XWDTPS_SR_OFFSET Details

| Field Name | Bits | Type | Reset Value | Description |
|---------------------------------|------|------|-------------|--|
| XWDTPS_SR_WDZ_MAS K (WDZ) | 0 | ro | 0x0 | set when the watchdog reaches zero count |

B.32 Triple Timer Counter (ttc)

| | |
|---------------|------------------------------------|
| Module Name | Triple Timer Counter (ttc) |
| Software Name | XTTCPS |
| Base Address | 0xF8001000 ttc0 0xF8002000 ttc1 |
| Description | Triple Timer Counter |
| Vendor Info | |

Register Summary

| Register Name | Address | Width | Type | Reset Value | Description |
|--|------------|-------|------|-------------|----------------------------|
| XTTCPS_CLK_CNTRL_OFFSET | 0x00000000 | 7 | rw | 0x00000000 | Clock Control register |
| Clock_Control_2 | 0x00000004 | 7 | rw | 0x00000000 | Clock Control register |
| Clock_Control_3 | 0x00000008 | 7 | rw | 0x00000000 | Clock Control register |
| XTTCPS_CNT_CNTRL_OFFSET | 0x0000000C | 7 | rw | 0x00000021 | Operational mode and reset |
| Counter_Control_2 | 0x00000010 | 7 | rw | 0x00000021 | Operational mode and reset |
| Counter_Control_3 | 0x00000014 | 7 | rw | 0x00000021 | Operational mode and reset |
| XTTCPS_COUNT_VALUE_OFFSET | 0x00000018 | 16 | ro | 0x00000000 | Current counter value |
| Counter_Value_2 | 0x0000001C | 16 | ro | 0x00000000 | Current counter value |
| Counter_Value_3 | 0x00000020 | 16 | ro | 0x00000000 | Current counter value |
| XTTCPS_INTERVAL_VAL_OFFSET | 0x00000024 | 16 | rw | 0x00000000 | Interval value |
| Interval_Counter_2 | 0x00000028 | 16 | rw | 0x00000000 | Interval value |
| Interval_Counter_3 | 0x0000002C | 16 | rw | 0x00000000 | Interval value |
| XTTCPS_MATCH_0_OFFSET | 0x00000030 | 16 | rw | 0x00000000 | Match value |
| Match_1_Counter_2 | 0x00000034 | 16 | rw | 0x00000000 | Match value |
| Match_1_Counter_3 | 0x00000038 | 16 | rw | 0x00000000 | Match value |
| XTTCPS_MATCH_1_OFFSET | 0x0000003C | 16 | rw | 0x00000000 | Match value |
| Match_2_Counter_2 | 0x00000040 | 16 | rw | 0x00000000 | Match value |
| Match_2_Counter_3 | 0x00000044 | 16 | rw | 0x00000000 | Match value |
| XTTCPS_MATCH_2_OFFSET | 0x00000048 | 16 | rw | 0x00000000 | Match value |
| Match_3_Counter_2 | 0x0000004C | 16 | rw | 0x00000000 | Match value |

| Register Name | Address | Width | Type | Reset Value | Description |
|---------------------------------------|------------|-------|--------|-------------|--|
| Match_3_Counter_3 | 0x00000050 | 16 | rw | 0x00000000 | Match value |
| XTTCPS_ISR_OFFSET | 0x00000054 | 6 | clonrd | 0x00000000 | Counter 1 Interval, Match, Overflow and Event interrupts |
| Interrupt_Register_2 | 0x00000058 | 6 | clonrd | 0x00000000 | Counter 2 Interval, Match, Overflow and Event interrupts |
| Interrupt_Register_3 | 0x0000005C | 6 | clonrd | 0x00000000 | Counter 3 Interval, Match, Overflow and Event interrupts |
| XTTCPS_IER_OFFSET | 0x00000060 | 6 | rw | 0x00000000 | ANDed with corresponding Interrupt Register |
| Interrupt_Enable_2 | 0x00000064 | 6 | rw | 0x00000000 | ANDed with corresponding Interrupt Register |
| Interrupt_Enable_3 | 0x00000068 | 6 | rw | 0x00000000 | ANDed with corresponding Interrupt Register |
| Event_Control_Timer_1 | 0x0000006C | 3 | rw | 0x00000000 | Enable, pulse and overflow |
| Event_Control_Timer_2 | 0x00000070 | 3 | rw | 0x00000000 | Enable, pulse and overflow |
| Event_Control_Timer_3 | 0x00000074 | 3 | rw | 0x00000000 | Enable, pulse and overflow |
| Event_Register_1 | 0x00000078 | 16 | ro | 0x00000000 | pclk cycle count for event |
| Event_Register_2 | 0x0000007C | 16 | ro | 0x00000000 | pclk cycle count for event |
| Event_Register_3 | 0x00000080 | 16 | ro | 0x00000000 | pclk cycle count for event |

Register (ttc) XTTCPS_CLK_CNTRL_OFFSET

| | |
|------------------|--------------------------------------|
| Name | XTTCPS_CLK_CNTRL_OFFSET |
| Software Name | CLK_CNTRL |
| Relative Address | 0x00000000 |
| Absolute Address | ttc0: 0xF8001000 ttc1: 0xF8002000 |
| Width | 7 bits |
| Access Type | rw |
| Reset Value | 0x00000000 |
| Description | Clock Control register |

Register XTTCPS_CLK_CNTRL_OFFSET Details

| Field Name | Bits | Type | Reset Value | Description |
|--|------|------|-------------|--|
| XTTCPS_CLK_CNTRL_EXT_EDGE_MASK (EXT_EDGE) | 6 | rw | 0x0 | External Clock Edge: when this bit is set and the extend clock is selected, the counter clocks on the negative going edge of the external clock input. |
| XTTCPS_CLK_CNTRL_SRC_MASK (SRC) | 5 | rw | 0x0 | Clock Source: when this bit is set the counter uses the external clock input, ext_clk; the default clock source is pclk. |
| XTTCPS_CLK_CNTRL_PS_VAL_MASK (PS_VAL) | 4:1 | rw | 0x0 | Prescale value (N): if prescale is enabled, the count rate is divided by 2 ^(N+1) |
| XTTCPS_CLK_CNTRL_PS_EN_MASK (PS_EN) | 0 | rw | 0x0 | Prescale enable: when this bit is set the counter, clock source is prescaled; the default clock source is that defined by C_Src.the default |

Register ([ttc](#)) Clock_Control_2

| | |
|------------------|--------------------------------------|
| Name | Clock_Control_2 |
| Relative Address | 0x00000004 |
| Absolute Address | ttc0: 0xF8001004 ttc1: 0xF8002004 |
| Width | 7 bits |
| Access Type | rw |
| Reset Value | 0x00000000 |
| Description | Clock Control register |

Register Clock_Control_2 Details

| Field Name | Bits | Type | Reset Value | Description |
|--|------|------|-------------|--|
| XTTCPS_CLK_CNTRL_EXT_EDGE_MASK (CLK_CNTRL_EXT_EDGE) | 6 | rw | 0x0 | External Clock Edge: when this bit is set and the extend clock is selected, the counter clocks on the negative going edge of the external clock input. |
| XTTCPS_CLK_CNTRL_SRC_MASK (CLK_CNTRL_SRC) | 5 | rw | 0x0 | Clock Source: when this bit is set the counter uses the external clock input, ext_clk; the default clock source is pclk. |
| XTTCPS_CLK_CNTRL_PS_VAL_MASK (CLK_CNTRL_PS_VAL) | 4:1 | rw | 0x0 | Prescale value (N): if prescale is enabled, the count rate is divided by 2 ^(N+1) |
| XTTCPS_CLK_CNTRL_PS_EN_MASK (CLK_CNTRL_PS_EN) | 0 | rw | 0x0 | Prescale enable: when this bit is set the counter, clock source is prescaled; the default clock source is that defined by C_Src.the default |

Register ([ttc](#)) Clock_Control_3

| | |
|------------------|--------------------------------------|
| Name | Clock_Control_3 |
| Relative Address | 0x00000008 |
| Absolute Address | ttc0: 0xF8001008 ttc1: 0xF8002008 |
| Width | 7 bits |
| Access Type | rw |
| Reset Value | 0x00000000 |
| Description | Clock Control register |

Register Clock_Control_3 Details

| Field Name | Bits | Type | Reset Value | Description |
|---|------|------|-------------|--|
| X TTCPS_CLK_CNTRL_EXT_EDGE_MASK (CLK_CNTRL_EXT_EDGE) | 6 | rw | 0x0 | External Clock Edge: when this bit is set and the extend clock is selected, the counter clocks on the negative going edge of the external clock input. |
| X TTCPS_CLK_CNTRL_SRC_MASK (CLK_CNTRL_SRC) | 5 | rw | 0x0 | Clock Source: when this bit is set the counter uses the external clock input, ext_clk; the default clock source is pclk. |
| X TTCPS_CLK_CNTRL_PS_VAL_MASK (CLK_CNTRL_PS_VAL) | 4:1 | rw | 0x0 | Prescale value (N): if prescale is enabled, the count rate is divided by $2^{(N+1)}$ |
| X TTCPS_CLK_CNTRL_PS_EN_MASK (CLK_CNTRL_PS_EN) | 0 | rw | 0x0 | Prescale enable: when this bit is set the counter, clock source is prescaled; the default clock source is that defined by C_Src.the default |

Register ([ttc](#)) XTTCPS_CNT_CNTRL_OFFSET

| | |
|------------------|--------------------------------------|
| Name | XTTCPS_CNT_CNTRL_OFFSET |
| Software Name | CNT_CNTRL |
| Relative Address | 0x0000000C |
| Absolute Address | ttc0: 0xF800100C ttc1: 0xF800200C |
| Width | 7 bits |
| Access Type | rw |
| Reset Value | 0x00000021 |
| Description | Operational mode and reset |

Register XTTCPS_CNT_CNTRL_OFFSET Details

| Field Name | Bits | Type | Reset Value | Description |
|--|------|------|-------------|---|
| XTTCPS_CNT_CNTRL_POL_WAVE_MASK (POL_WAVE) | 6 | rw | 0x0 | Waveform polarity: When this bit is high, the waveform output goes from high to low on Match_1 interrupt and returns high on overflow or interval interrupt; when low, the waveform goes from low to high on Match_1 interrupt and returns low on overflow or interval interrupt. |
| XTTCPS_CNT_CNTRL_EN_WAVE_MASK (EN_WAVE) | 5 | rw | 0x1 | Output waveform enable, active low. |
| XTTCPS_CNT_CNTRL_RST_MASK (RST) | 4 | rw | 0x0 | Setting this bit high resets the counter value and restarts counting; the RST bit is automatically cleared on restart. |
| XTTCPS_CNT_CNTRL_MATCH_MASK (MATCH) | 3 | rw | 0x0 | Register Match mode: when Match is set, an interrupt is generated when the count value matches one of the three match registers and the corresponding bit is set in the Interrupt Enable register. |
| XTTCPS_CNT_CNTRL_DECR_MASK (DECR) | 2 | rw | 0x0 | Decrement: when this bit is high the counter counts down. |
| XTTCPS_CNT_CNTRL_INTERVAL_MASK (INT) | 1 | rw | 0x0 | When this bit is high, the timer is in Interval Mode, and the counter generates interrupts at regular intervals; when low, the timer is in overflow mode. |
| XTTCPS_CNT_CNTRL_DISABLE_MASK (DIS) | 0 | rw | 0x1 | Disable counter: when this bit is high, the counter is stopped, holding its last value until reset, restarted or enabled again. |

Register ([ttc](#)) Counter_Control_2

| | |
|------------------|--------------------------------------|
| Name | Counter_Control_2 |
| Relative Address | 0x00000010 |
| Absolute Address | ttc0: 0xF8001010 ttc1: 0xF8002010 |
| Width | 7 bits |
| Access Type | rw |
| Reset Value | 0x00000021 |
| Description | Operational mode and reset |

Register Counter_Control_2 Details

| Field Name | Bits | Type | Reset Value | Description |
|---|------|------|-------------|---|
| X TTCPS_CNT_CNTRL_P OL_WAVE_MASK (CNT_CNTRL_POL_WAVE) | 6 | rw | 0x0 | Waveform polarity: When this bit is high, the waveform output goes from high to low on Match_1 interrupt and returns high on overflow or interval interrupt; when low, the waveform goes from low to high on Match_1 interrupt and returns low on overflow or interval interrupt. |
| X TTCPS_CNT_CNTRL_E N_WAVE_MASK (CNT_CNTRL_EN_WAVE) | 5 | rw | 0x1 | Output waveform enable, active low. |
| X TTCPS_CNT_CNTRL_R ST_MASK (CNT_CNTRL_RST) | 4 | rw | 0x0 | Setting this bit high resets the counter value and restarts counting; the RST bit is automatically cleared on restart. |
| X TTCPS_CNT_CNTRL_M ATCH_MASK (CNT_CNTRL_MATCH) | 3 | rw | 0x0 | Register Match mode: when Match is set, an interrupt is generated when the count value matches one of the three match registers and the corresponding bit is set in the Interrupt Enable register. |
| X TTCPS_CNT_CNTRL_D ECR_MASK (CNT_CNTRL_DECR) | 2 | rw | 0x0 | Decrement: when this bit is high the counter counts down. |
| X TTCPS_CNT_CNTRL_I NT_MASK (CNT_CNTRL_INT) | 1 | rw | 0x0 | When this bit is high, the timer is in Interval Mode, and the counter generates interrupts at regular intervals; when low, the timer is in overflow mode. |
| X TTCPS_CNT_CNTRL_DI S_MASK (CNT_CNTRL_DIS) | 0 | rw | 0x1 | Disable counter: when this bit is high, the counter is stopped, holding its last value until reset, restarted or enabled again. |

Register (ttc) Counter_Control_3

| | |
|------------------|--------------------------------------|
| Name | Counter_Control_3 |
| Relative Address | 0x00000014 |
| Absolute Address | ttc0: 0xF8001014 ttc1: 0xF8002014 |
| Width | 7 bits |
| Access Type | rw |
| Reset Value | 0x00000021 |
| Description | Operational mode and reset |

Register Counter_Control_3 Details

| Field Name | Bits | Type | Reset Value | Description |
|---|------|------|-------------|---|
| X TTCPS_CNT_CNTRL_P OL_WAVE_MASK (CNT_CNTRL_POL_WAVE) | 6 | rw | 0x0 | Waveform polarity: When this bit is high, the waveform output goes from high to low on Match_1 interrupt and returns high on overflow or interval interrupt; when low, the waveform goes from low to high on Match_1 interrupt and returns low on overflow or interval interrupt. |
| X TTCPS_CNT_CNTRL_E N_WAVE_MASK (CNT_CNTRL_EN_WAVE) | 5 | rw | 0x1 | Output waveform enable, active low. |
| X TTCPS_CNT_CNTRL_R ST_MASK (CNT_CNTRL_RST) | 4 | rw | 0x0 | Setting this bit high resets the counter value and restarts counting; the RST bit is automatically cleared on restart. |
| X TTCPS_CNT_CNTRL_M ATCH_MASK (CNT_CNTRL_MATCH) | 3 | rw | 0x0 | Register Match mode: when Match is set, an interrupt is generated when the count value matches one of the three match registers and the corresponding bit is set in the Interrupt Enable register. |
| X TTCPS_CNT_CNTRL_D ECR_MASK (CNT_CNTRL_DECR) | 2 | rw | 0x0 | Decrement: when this bit is high the counter counts down. |
| X TTCPS_CNT_CNTRL_I NT_MASK (CNT_CNTRL_INT) | 1 | rw | 0x0 | When this bit is high, the timer is in Interval Mode, and the counter generates interrupts at regular intervals; when low, the timer is in overflow mode. |
| X TTCPS_CNT_CNTRL_D S_MASK (CNT_CNTRL_DIS) | 0 | rw | 0x1 | Disable counter: when this bit is high, the counter is stopped, holding its last value until reset, restarted or enabled again. |

Register (ttc) X TTCPS_COUNT_VALUE_OFFSET

| | |
|------------------|--------------------------------------|
| Name | X TTCPS_COUNT_VALUE_OFFSET |
| Software Name | COUNT_VALUE |
| Relative Address | 0x00000018 |
| Absolute Address | ttc0: 0xF8001018 ttc1: 0xF8002018 |
| Width | 16 bits |
| Access Type | ro |
| Reset Value | 0x00000000 |
| Description | Current counter value |

Register XTTCPS_COUNT_VALUE_OFFSET Details

| Field Name | Bits | Type | Reset Value | Description |
|-----------------------------------|------|------|-------------|---|
| XTTCPS_COUNT_VALUE_MASK (MASK) | 15:0 | ro | 0x0 | At any time, a Timer Counter's count value can be read from its Counter Value Register. |

Register ([ttc](#)) Counter_Value_2

| | |
|------------------|--------------------------------------|
| Name | Counter_Value_2 |
| Relative Address | 0x0000001C |
| Absolute Address | ttc0: 0xF800101C ttc1: 0xF800201C |
| Width | 16 bits |
| Access Type | ro |
| Reset Value | 0x00000000 |
| Description | Current counter value |

Register Counter_Value_2 Details

| Field Name | Bits | Type | Reset Value | Description |
|--|------|------|-------------|---|
| XTTCPS_COUNT_VALUE_MASK (COUNT_VALUE) | 15:0 | ro | 0x0 | At any time, a Timer Counter's count value can be read from its Counter Value Register. |

Register ([ttc](#)) Counter_Value_3

| | |
|------------------|--------------------------------------|
| Name | Counter_Value_3 |
| Relative Address | 0x00000020 |
| Absolute Address | ttc0: 0xF8001020 ttc1: 0xF8002020 |
| Width | 16 bits |
| Access Type | ro |
| Reset Value | 0x00000000 |
| Description | Current counter value |

Register Counter_Value_3 Details

| Field Name | Bits | Type | Reset Value | Description |
|---|------|------|-------------|---|
| X TTCPS_COUNT_VALUE_MASK (COUNT_VALUE) | 15:0 | ro | 0x0 | At any time, a Timer Counter's count value can be read from its Counter Value Register. |

Register (ttc) XTTCPS_INTERVAL_VAL_OFFSET

| | |
|------------------|--------------------------------------|
| Name | XTTCPS_INTERVAL_VAL_OFFSET |
| Software Name | INTERVAL_VAL |
| Relative Address | 0x00000024 |
| Absolute Address | ttc0: 0xF8001024 ttc1: 0xF8002024 |
| Width | 16 bits |
| Access Type | rw |
| Reset Value | 0x00000000 |
| Description | Interval value |

Register XTTCPS_INTERVAL_VAL_OFFSET Details

| Field Name | Bits | Type | Reset Value | Description |
|---|------|------|-------------|---|
| X TTCPS_COUNT_VALUE_MASK (COUNT_VALUE) | 15:0 | rw | 0x0 | If interval is enabled, this is the maximum value that the counter will count up to or down from. |

Register (ttc) Interval_Counter_2

| | |
|------------------|--------------------------------------|
| Name | Interval_Counter_2 |
| Relative Address | 0x00000028 |
| Absolute Address | ttc0: 0xF8001028 ttc1: 0xF8002028 |
| Width | 16 bits |
| Access Type | rw |
| Reset Value | 0x00000000 |
| Description | Interval value |

Register Interval_Counter_2 Details

| Field Name | Bits | Type | Reset Value | Description |
|---|------|------|-------------|---|
| X TTCPS_INTERVAL_VAL_MASK (INTERVAL_VAL) | 15:0 | rw | 0x0 | If interval is enabled, this is the maximum value that the counter will count up to or down from. |

Register ([ttc](#)) Interval_Counter_3

| | |
|------------------|--------------------------------------|
| Name | Interval_Counter_3 |
| Relative Address | 0x0000002C |
| Absolute Address | ttc0: 0xF800102C ttc1: 0xF800202C |
| Width | 16 bits |
| Access Type | rw |
| Reset Value | 0x00000000 |
| Description | Interval value |

Register Interval_Counter_3 Details

| Field Name | Bits | Type | Reset Value | Description |
|---|------|------|-------------|---|
| X TTCPS_INTERVAL_VAL_MASK (INTERVAL_VAL) | 15:0 | rw | 0x0 | If interval is enabled, this is the maximum value that the counter will count up to or down from. |

Register ([ttc](#)) X TTCPS_MATCH_0_OFFSET

| | |
|------------------|--------------------------------------|
| Name | X TTCPS_MATCH_0_OFFSET |
| Software Name | MATCH_0 |
| Relative Address | 0x00000030 |
| Absolute Address | ttc0: 0xF8001030 ttc1: 0xF8002030 |
| Width | 16 bits |
| Access Type | rw |
| Reset Value | 0x00000000 |
| Description | Match value |

Register XTTCPS_MATCH_0_OFFSET Details

| Field Name | Bits | Type | Reset Value | Description |
|---------------------------|------|------|-------------|---|
| XTTCPS_MATCH_MASK (MATCH) | 15:0 | rw | 0x0 | When a counter has the same value as is stored in one of its match registers and match mode is enabled, a match interrupt is generated. Each counter has three match registers. |

Register ([ttc](#)) Match_1_Counter_2

| | |
|------------------|--------------------------------------|
| Name | Match_1_Counter_2 |
| Relative Address | 0x00000034 |
| Absolute Address | ttc0: 0xF8001034 ttc1: 0xF8002034 |
| Width | 16 bits |
| Access Type | rw |
| Reset Value | 0x00000000 |
| Description | Match value |

Register Match_1_Counter_2 Details

| Field Name | Bits | Type | Reset Value | Description |
|---------------------------|------|------|-------------|---|
| XTTCPS_MATCH_MASK (MATCH) | 15:0 | rw | 0x0 | When a counter has the same value as is stored in one of its match registers and match mode is enabled, a match interrupt is generated. Each counter has three match registers. |

Register ([ttc](#)) Match_1_Counter_3

| | |
|------------------|--------------------------------------|
| Name | Match_1_Counter_3 |
| Relative Address | 0x00000038 |
| Absolute Address | ttc0: 0xF8001038 ttc1: 0xF8002038 |
| Width | 16 bits |
| Access Type | rw |
| Reset Value | 0x00000000 |
| Description | Match value |

Register Match_1_Counter_3 Details

| Field Name | Bits | Type | Reset Value | Description |
|----------------------------|------|------|-------------|---|
| X TTCPS_MATCH_MASK (MATCH) | 15:0 | rw | 0x0 | When a counter has the same value as is stored in one of its match registers and match mode is enabled, a match interrupt is generated. Each counter has three match registers. |

Register ([ttc](#)) X TTCPS_MATCH_1_OFFSET

| | |
|------------------|--------------------------------------|
| Name | X TTCPS_MATCH_1_OFFSET |
| Software Name | MATCH_1 |
| Relative Address | 0x0000003C |
| Absolute Address | ttc0: 0xF800103C ttc1: 0xF800203C |
| Width | 16 bits |
| Access Type | rw |
| Reset Value | 0x00000000 |
| Description | Match value |

Register X TTCPS_MATCH_1_OFFSET Details

| Field Name | Bits | Type | Reset Value | Description |
|----------------------------|------|------|-------------|---|
| X TTCPS_MATCH_MASK (MATCH) | 15:0 | rw | 0x0 | When a counter has the same value as is stored in one of its match registers and match mode is enabled, a match interrupt is generated. Each counter has three match registers. |

Register ([ttc](#)) Match_2_Counter_2

| | |
|------------------|--------------------------------------|
| Name | Match_2_Counter_2 |
| Relative Address | 0x00000040 |
| Absolute Address | ttc0: 0xF8001040 ttc1: 0xF8002040 |
| Width | 16 bits |
| Access Type | rw |
| Reset Value | 0x00000000 |
| Description | Match value |

Register Match_2_Counter_2 Details

| Field Name | Bits | Type | Reset Value | Description |
|----------------------------|------|------|-------------|---|
| X TTCPS_MATCH_MASK (MATCH) | 15:0 | rw | 0x0 | When a counter has the same value as is stored in one of its match registers and match mode is enabled, a match interrupt is generated. Each counter has three match registers. |

Register ([ttc](#)) Match_2_Counter_3

| | |
|------------------|--------------------------------------|
| Name | Match_2_Counter_3 |
| Relative Address | 0x00000044 |
| Absolute Address | ttc0: 0xF8001044 ttc1: 0xF8002044 |
| Width | 16 bits |
| Access Type | rw |
| Reset Value | 0x00000000 |
| Description | Match value |

Register Match_2_Counter_3 Details

| Field Name | Bits | Type | Reset Value | Description |
|----------------------------|------|------|-------------|---|
| X TTCPS_MATCH_MASK (MATCH) | 15:0 | rw | 0x0 | When a counter has the same value as is stored in one of its match registers and match mode is enabled, a match interrupt is generated. Each counter has three match registers. |

Register ([ttc](#)) X TTCPS_MATCH_2_OFFSET

| | |
|------------------|--------------------------------------|
| Name | X TTCPS_MATCH_2_OFFSET |
| Software Name | MATCH_2 |
| Relative Address | 0x00000048 |
| Absolute Address | ttc0: 0xF8001048 ttc1: 0xF8002048 |
| Width | 16 bits |
| Access Type | rw |
| Reset Value | 0x00000000 |
| Description | Match value |

Register XTTCPS_MATCH_2_OFFSET Details

| Field Name | Bits | Type | Reset Value | Description |
|---------------------------|------|------|-------------|---|
| XTTCPS_MATCH_MASK (MATCH) | 15:0 | rw | 0x0 | When a counter has the same value as is stored in one of its match registers and match mode is enabled, a match interrupt is generated. Each counter has three match registers. |

Register ([ttc](#)) Match_3_Counter_2

| | |
|------------------|--------------------------------------|
| Name | Match_3_Counter_2 |
| Relative Address | 0x0000004C |
| Absolute Address | ttc0: 0xF800104C ttc1: 0xF800204C |
| Width | 16 bits |
| Access Type | rw |
| Reset Value | 0x00000000 |
| Description | Match value |

Register Match_3_Counter_2 Details

| Field Name | Bits | Type | Reset Value | Description |
|---------------------------|------|------|-------------|---|
| XTTCPS_MATCH_MASK (MATCH) | 15:0 | rw | 0x0 | When a counter has the same value as is stored in one of its match registers and match mode is enabled, a match interrupt is generated. Each counter has three match registers. |

Register ([ttc](#)) Match_3_Counter_3

| | |
|------------------|--------------------------------------|
| Name | Match_3_Counter_3 |
| Relative Address | 0x00000050 |
| Absolute Address | ttc0: 0xF8001050 ttc1: 0xF8002050 |
| Width | 16 bits |
| Access Type | rw |
| Reset Value | 0x00000000 |
| Description | Match value |

Register Match_3_Counter_3 Details

| Field Name | Bits | Type | Reset Value | Description |
|----------------------------|------|------|-------------|---|
| X TTCPS_MATCH_MASK (MATCH) | 15:0 | rw | 0x0 | When a counter has the same value as is stored in one of its match registers and match mode is enabled, a match interrupt is generated. Each counter has three match registers. |

Register ([ttc](#)) X TTCPS_ISR_OFFSET

| | |
|------------------|--|
| Name | X TTCPS_ISR_OFFSET |
| Software Name | ISR |
| Relative Address | 0x00000054 |
| Absolute Address | ttc0: 0xF8001054 ttc1: 0xF8002054 |
| Width | 6 bits |
| Access Type | clonrd |
| Reset Value | 0x00000000 |
| Description | Counter 1 Interval, Match, Overflow and Event interrupts |

Register X TTCPS_ISR_OFFSET Details

| Field Name | Bits | Type | Reset Value | Description |
|--|------|--------|-------------|--------------------------------|
| Ev | 5 | clonrd | 0x0 | Event timer overflow interrupt |
| X TTCPS_I XR_CNT_OVR_MASK (I XR_CNT_OVR) | 4 | clonrd | 0x0 | Counter overflow |
| X TTCPS_I XR_MATCH_2_MASK (I XR_MATCH_2) | 3 | clonrd | 0x0 | Match 3 interrupt |
| X TTCPS_I XR_MATCH_1_MASK (I XR_MATCH_1) | 2 | clonrd | 0x0 | Match 2 interrupt |
| X TTCPS_I XR_MATCH_0_MASK (I XR_MATCH_0) | 1 | clonrd | 0x0 | Match 1 interrupt |
| X TTCPS_I XR_INTERVAL_MASK (I XR_INTERVAL) | 0 | clonrd | 0x0 | Interval interrupt |

Register ([ttc](#)) Interrupt_Register_2

Name Interrupt_Register_2
 Relative Address 0x00000058
 Absolute Address ttc0: 0xF8001058
 ttc1: 0xF8002058
 Width 6 bits
 Access Type clonrd
 Reset Value 0x00000000
 Description Counter 2 Interval, Match, Overflow and Event interrupts

Register Interrupt_Register_2 Details

| Field Name | Bits | Type | Reset Value | Description |
|--|------|--------|-------------|--------------------------------|
| Ev | 5 | clonrd | 0x0 | Event timer overflow interrupt |
| XTTCPS_IXR_CNT_OVR_MASK (IXR_CNT_OVR) | 4 | clonrd | 0x0 | Counter overflow |
| XTTCPS_IXR_MATCH_2_MASK (IXR_MATCH_2) | 3 | clonrd | 0x0 | Match 3 interrupt |
| XTTCPS_IXR_MATCH_1_MASK (IXR_MATCH_1) | 2 | clonrd | 0x0 | Match 2 interrupt |
| XTTCPS_IXR_MATCH_0_MASK (IXR_MATCH_0) | 1 | clonrd | 0x0 | Match 1 interrupt |
| XTTCPS_IXR_INTERVAL_MASK (IXR_INTERVAL) | 0 | clonrd | 0x0 | Interval interrupt |

Register ([ttc](#)) Interrupt_Register_3

Name Interrupt_Register_3
 Relative Address 0x0000005C
 Absolute Address ttc0: 0xF800105C
 ttc1: 0xF800205C
 Width 6 bits
 Access Type clonrd
 Reset Value 0x00000000
 Description Counter 3 Interval, Match, Overflow and Event interrupts

Register Interrupt_Register_3 Details

| Field Name | Bits | Type | Reset Value | Description |
|--|------|--------|-------------|--------------------------------|
| Ev | 5 | clonrd | 0x0 | Event timer overflow interrupt |
| X TTCPS_I XR_CNT_OVR_MASK (IXR_CNT_OVR) | 4 | clonrd | 0x0 | Counter overflow |
| X TTCPS_I XR_MATCH_2_MASK (IXR_MATCH_2) | 3 | clonrd | 0x0 | Match 3 interrupt |
| X TTCPS_I XR_MATCH_1_MASK (IXR_MATCH_1) | 2 | clonrd | 0x0 | Match 2 interrupt |
| X TTCPS_I XR_MATCH_0_MASK (IXR_MATCH_0) | 1 | clonrd | 0x0 | Match 1 interrupt |
| X TTCPS_I XR_INTERVAL_MASK (IXR_INTERVAL) | 0 | clonrd | 0x0 | Interval interrupt |

Register ([ttc](#)) X TTCPS_I ER_OFFSET

| | |
|------------------|---|
| Name | X TTCPS_I ER_OFFSET |
| Software Name | IER |
| Relative Address | 0x00000060 |
| Absolute Address | ttc0: 0xF8001060 ttc1: 0xF8002060 |
| Width | 6 bits |
| Access Type | rw |
| Reset Value | 0x00000000 |
| Description | ANDed with corresponding Interrupt Register |

Register X TTCPS_I ER_OFFSET Details

| Field Name | Bits | Type | Reset Value | Description |
|------------|------|------|-------------|---|
| IEN | 5:0 | rw | 0x0 | Enables for bits 05:00 in Interrupt Register: corresponding bits must be set to enable the interrupt. |

Register ([ttc](#)) Interrupt_Enable_2

| | |
|------------------|---|
| Name | Interrupt_Enable_2 |
| Relative Address | 0x00000064 |
| Absolute Address | ttc0: 0xF8001064 ttc1: 0xF8002064 |
| Width | 6 bits |
| Access Type | rw |
| Reset Value | 0x00000000 |
| Description | ANDed with corresponding Interrupt Register |

Register Interrupt_Enable_2 Details

| Field Name | Bits | Type | Reset Value | Description |
|------------|------|------|-------------|---|
| IEN | 5:0 | rw | 0x0 | Enables for bits 05:00 in Interrupt Register: corresponding bits must be set to enable the interrupt. |

Register ([ttc](#)) Interrupt_Enable_3

| | |
|------------------|---|
| Name | Interrupt_Enable_3 |
| Relative Address | 0x00000068 |
| Absolute Address | ttc0: 0xF8001068 ttc1: 0xF8002068 |
| Width | 6 bits |
| Access Type | rw |
| Reset Value | 0x00000000 |
| Description | ANDed with corresponding Interrupt Register |

Register Interrupt_Enable_3 Details

| Field Name | Bits | Type | Reset Value | Description |
|------------|------|------|-------------|---|
| IEN | 5:0 | rw | 0x0 | Enables for bits 05:00 in Interrupt Register: corresponding bits must be set to enable the interrupt. |

Register ([ttc](#)) Event_Control_Timer_1

| | |
|------|-----------------------|
| Name | Event_Control_Timer_1 |
|------|-----------------------|

Relative Address 0x0000006C
 Absolute Address ttc0: 0xF800106C
 ttc1: 0xF800206C
 Width 3 bits
 Access Type rw
 Reset Value 0x00000000
 Description Enable, pulse and overflow

Register Event_Control_Timer_1 Details

| Field Name | Bits | Type | Reset Value | Description |
|------------|------|------|-------------|--|
| E_Ov | 2 | rw | 0x0 | When this bit is low, the event timer is disabled and set to zero when an Event Timer Register overflow occurs; when set high, the timer continues counting on overflow. |
| E_Lo | 1 | rw | 0x0 | When this bit is high, the timer counts pclk cycles during the low level duration of ext_clk; when low, the event timer counts the high level duration of ext_clk. |
| E_En | 0 | rw | 0x0 | Enable timer: when this bit is high, the event timer is enabled. |

Register ([ttc](#)) Event_Control_Timer_2

Name Event_Control_Timer_2
 Relative Address 0x00000070
 Absolute Address ttc0: 0xF8001070
 ttc1: 0xF8002070
 Width 3 bits
 Access Type rw
 Reset Value 0x00000000
 Description Enable, pulse and overflow

Register Event_Control_Timer_2 Details

| Field Name | Bits | Type | Reset Value | Description |
|------------|------|------|-------------|--|
| E_Ov | 2 | rw | 0x0 | When this bit is low, the event timer is disabled and set to zero when an Event Timer Register overflow occurs; when set high, the timer continues counting on overflow. |

| Field Name | Bits | Type | Reset Value | Description |
|------------|------|------|-------------|--|
| E_Lo | 1 | rw | 0x0 | When this bit is high, the timer counts pclk cycles during the low level duration of ext_clk; when low, the event timer counts the high level duration of ext_clk. |
| E_En | 0 | rw | 0x0 | Enable timer: when this bit is high, the event timer is enabled. |

Register ([ttc](#)) Event_Control_Timer_3

| | |
|------------------|--------------------------------------|
| Name | Event_Control_Timer_3 |
| Relative Address | 0x00000074 |
| Absolute Address | ttc0: 0xF8001074 ttc1: 0xF8002074 |
| Width | 3 bits |
| Access Type | rw |
| Reset Value | 0x00000000 |
| Description | Enable, pulse and overflow |

Register Event_Control_Timer_3 Details

| Field Name | Bits | Type | Reset Value | Description |
|------------|------|------|-------------|--|
| E_Ov | 2 | rw | 0x0 | When this bit is low, the event timer is disabled and set to zero when an Event Timer Register overflow occurs; when set high, the timer continues counting on overflow. |
| E_Lo | 1 | rw | 0x0 | When this bit is high, the timer counts pclk cycles during the low level duration of ext_clk; when low, the event timer counts the high level duration of ext_clk. |
| E_En | 0 | rw | 0x0 | Enable timer: when this bit is high, the event timer is enabled. |

Register ([ttc](#)) Event_Register_1

| | |
|------------------|--------------------------------------|
| Name | Event_Register_1 |
| Relative Address | 0x00000078 |
| Absolute Address | ttc0: 0xF8001078 ttc1: 0xF8002078 |
| Width | 16 bits |
| Access Type | ro |
| Reset Value | 0x00000000 |
| Description | pclk cycle count for event |

Register Event_Register_1 Details

| Field Name | Bits | Type | Reset Value | Description |
|------------|------|------|-------------|---|
| Event | 15:0 | ro | 0x0 | This register stores the result of the pclk count during the ext_clk high or low pulse. |

Register ([ttc](#)) Event_Register_2

| | |
|------------------|--------------------------------------|
| Name | Event_Register_2 |
| Relative Address | 0x0000007C |
| Absolute Address | ttc0: 0xF800107C ttc1: 0xF800207C |
| Width | 16 bits |
| Access Type | ro |
| Reset Value | 0x00000000 |
| Description | pclk cycle count for event |

Register Event_Register_2 Details

| Field Name | Bits | Type | Reset Value | Description |
|------------|------|------|-------------|---|
| Event | 15:0 | ro | 0x0 | This register stores the result of the pclk count during the ext_clk high or low pulse. |

Register ([ttc](#)) Event_Register_3

| | |
|------------------|--------------------------------------|
| Name | Event_Register_3 |
| Relative Address | 0x00000080 |
| Absolute Address | ttc0: 0xF8001080 ttc1: 0xF8002080 |
| Width | 16 bits |
| Access Type | ro |
| Reset Value | 0x00000000 |
| Description | pclk cycle count for event |

Register Event_Register_3 Details

| Field Name | Bits | Type | Reset Value | Description |
|------------|------|------|-------------|---|
| Event | 15:0 | ro | 0x0 | This register stores the result of the pclk count during the ext_clk high or low pulse. |

B.33 UART Controller (UART)

| | |
|---------------|---|
| Module Name | UART Controller (UART) |
| Software Name | XUARTPS |
| Base Address | 0xE0000000 uart0 0xE0001000 uart1 |
| Description | Universal Asynchronous Receiver Transmitter |
| Vendor Info | Cadence UART |

Register Summary

| Register Name | Address | Width | Type | Reset Value | Description |
|--|------------|-------|-------|-------------|---|
| XUARTPS_CR_OFFSET | 0x00000000 | 32 | mixed | 0x00000128 | UART Control Register |
| XUARTPS_MR_OFFSET | 0x00000004 | 32 | mixed | 0x00000000 | UART Mode Register |
| XUARTPS_IER_OFFSET | 0x00000008 | 32 | mixed | 0x00000000 | Interrupt Enable Register |
| XUARTPS_IDR_OFFSET | 0x0000000C | 32 | mixed | 0x00000000 | Interrupt Disable Register |
| XUARTPS_IMR_OFFSET | 0x00000010 | 32 | ro | 0x00000000 | Interrupt Mask Register |
| XUARTPS_ISR_OFFSET | 0x00000014 | 32 | wtc | 0x00000000 | Channel Interrupt Status Register |
| XUARTPS_BAUDGEN_OFFSET | 0x00000018 | 32 | mixed | 0x0000028B | Baud Rate Generator Register. |
| XUARTPS_RXTOUT_OFFSET | 0x0000001C | 32 | mixed | 0x00000000 | Receiver Timeout Register |
| XUARTPS_RXWM_OFFSET | 0x00000020 | 32 | mixed | 0x00000020 | Receiver FIFO Trigger Level Register |
| XUARTPS_MODEMCR_OFFSET | 0x00000024 | 32 | mixed | 0x00000000 | Modem Control Register |
| XUARTPS_MODEMSR_OFFSET | 0x00000028 | 32 | mixed | x | Modem Status Register |
| XUARTPS_SR_OFFSET | 0x0000002C | 32 | ro | 0x00000000 | Channel Status Register |
| XUARTPS_FIFO_OFFSET | 0x00000030 | 32 | mixed | 0x00000000 | Transmit and Receive FIFO |
| Baud_rate_divider_reg0 | 0x00000034 | 32 | mixed | 0x0000000F | Baud Rate Divider Register |
| Flow_delay_reg0 | 0x00000038 | 32 | mixed | 0x00000000 | Flow Control Delay Register |
| Tx_FIFO_trigger_level0 | 0x00000044 | 32 | mixed | 0x00000020 | Transmitter FIFO Trigger Level Register |

Register ([UART](#)) XUARTPS_CR_OFFSET

Name XUARTPS_CR_OFFSET

| | |
|------------------|--|
| Software Name | CR |
| Relative Address | 0x00000000 |
| Absolute Address | uart0: 0xE0000000 uart1: 0xE0001000 |
| Width | 32 bits |
| Access Type | mixed |
| Reset Value | 0x00000128 |
| Description | UART Control Register |

Register XUARTPS_CR_OFFSET Details

The UART Control register is used to enable and reset the transmitter and receiver blocks. It also controls the receiver timeout and the transmission of breaks.

| Field Name | Bits | Type | Reset Value | Description |
|--------------------------------|------|------|-------------|---|
| reserved | 31:9 | ro | 0x0 | Reserved, read as zero, ignored on write. |
| XUARTPS_CR_STOPBRK (STOPBRK) | 8 | rw | 0x1 | Stop transmitter break: 0: no affect 1: stop transmission of the break after a minimum of one character length and transmit a high level during 12 bit periods. It can be set regardless of the value of STTBRK. |
| XUARTPS_CR_STARTBRK (STARTBRK) | 7 | rw | 0x0 | Start transmitter break: 0: no affect 1: start to transmit a break after the characters currently present in the FIFO and the transmit shift register have been transmitted. It can only be set if STPBRK (Stop transmitter break) is not high. |
| XUARTPS_CR_TORST (TORST) | 6 | rw | 0x0 | Restart receiver timeout counter: 1: receiver timeout counter is restarted. This bit is self clearing once the restart has completed. |
| XUARTPS_CR_TX_DIS (TX_DIS) | 5 | rw | 0x1 | Transmit disable: 0: enable transmitter 1: disable transmitter |
| XUARTPS_CR_TX_EN (TX_EN) | 4 | rw | 0x0 | Transmit enable: 0: disable transmitter 1: enable transmitter, provided the TXDIS field is set to 0. |
| XUARTPS_CR_RX_DIS (RX_DIS) | 3 | rw | 0x1 | Receive disable: 0: enable 1: disable, regardless of the value of RXEN |

| Field Name | Bits | Type | Reset Value | Description |
|-----------------------------|------|------|-------------|--|
| XUARTPS_CR_RX_EN (RX_EN) | 2 | rw | 0x0 | Receive enable: 0: disable 1: enable When set to one, the receiver logic is enabled, provided the RXDIS field is set to zero. |
| XUARTPS_CR_TXRST (TXRST) | 1 | rw | 0x0 | Software reset for Tx data path: 0: no affect 1: transmitter logic is reset and all pending transmitter data is discarded This bit is self clearing once the reset has completed. |
| XUARTPS_CR_RXRST (RXRST) | 0 | rw | 0x0 | Software reset for Rx data path: 0: no affect 1: receiver logic is reset and all pending receiver data is discarded. This bit is self clearing once the reset has completed. |

Register ([UART](#)) XUARTPS_MR_OFFSET

| | |
|------------------|--|
| Name | XUARTPS_MR_OFFSET |
| Software Name | MR |
| Relative Address | 0x00000004 |
| Absolute Address | uart0: 0xE0000004 uart1: 0xE0001004 |
| Width | 32 bits |
| Access Type | mixed |
| Reset Value | 0x00000000 |
| Description | UART Mode Register |

Register XUARTPS_MR_OFFSET Details

The UART Mode register defines the setup of the data format to be transmitted or received. If this register is modified during transmission or reception, data validity cannot be guaranteed.

| Field Name | Bits | Type | Reset Value | Description |
|------------|-------|------|-------------|---|
| reserved | 31:12 | ro | 0x0 | Reserved, read as zero, ignored on write. |
| reserved | 11 | rw | 0x0 | Reserved. Do not modify. |
| reserved | 10 | rw | 0x0 | Reserved. Do not modify. |

| Field Name | Bits | Type | Reset Value | Description |
|----------------------------|------|------|-------------|---|
| CHMODE | 9:8 | rw | 0x0 | Channel mode: Defines the mode of operation of the UART. 00: normal 01: automatic echo 10: local loopback 11: remote loopback |
| NBSTOP | 7:6 | rw | 0x0 | Number of stop bits: Defines the number of stop bits to detect on receive and to generate on transmit. 00: 1 stop bit 01: 1.5 stop bits 10: 2 stop bits 11: reserved |
| PAR | 5:3 | rw | 0x0 | Parity type select: Defines the expected parity to check on receive and the parity to generate on transmit. 000: even parity 001: odd parity 010: forced to 0 parity (space) 011: forced to 1 parity (mark) 1xx: no parity |
| CHRL | 2:1 | rw | 0x0 | Character length select: Defines the number of bits in each character. 11: 6 bits 10: 7 bits 0x: 8 bits |
| XUARTPS_MR_CLKSEL (CLKSEL) | 0 | rw | 0x0 | Clock source select: This field defines whether a pre-scalar of 8 is applied to the baud rate generator input clock. 0: clock source is uart_ref_clk 1: clock source is uart_ref_clk/8 |

Register ([UART](#)) XUARTPS_IER_OFFSET

| | |
|------------------|--|
| Name | XUARTPS_IER_OFFSET |
| Software Name | IER |
| Relative Address | 0x00000008 |
| Absolute Address | uart0: 0xE0000008 uart1: 0xE0001008 |
| Width | 32 bits |
| Access Type | mixed |
| Reset Value | 0x00000000 |
| Description | Interrupt Enable Register |

Register XUARTPS_IER_OFFSET Details

This write only register is used to enable interrupts. When any bit is written high, the corresponding interrupt is enabled. Writing a low to any bit has no effect.

| Field Name | Bits | Type | Reset Value | Description |
|--|-------|------|-------------|--|
| reserved | 31:13 | ro | 0x0 | Reserved, read as zero, ignored on write. |
| TOVR | 12 | wo | 0x0 | Transmitter FIFO Overflow interrupt: 0: no affect 1: enable (clears mask = 0) |
| TNFUL | 11 | wo | 0x0 | Transmitter FIFO Nearly Full interrupt: 0: no affect 1: enable (clears mask = 0) |
| TTRIG | 10 | wo | 0x0 | Transmitter FIFO Trigger interrupt: 0: disable 1: enable |
| XUARTPS_IXR_DMS (IXR_DMS) | 9 | wo | 0x0 | Delta Modem Status Indicator interrupt: 0: no affect 1: enable (clears mask = 0) |
| XUARTPS_IXR_TOUT (IXR_TOUT) | 8 | wo | 0x0 | Receiver Timeout Error interrupt: 0: no affect 1: enable (clears mask = 0) |
| XUARTPS_IXR_PARITY (IXR_PARITY) | 7 | wo | 0x0 | Receiver Parity Error interrupt: 0: disable 1: enable |
| XUARTPS_IXR_FRAMIN G (IXR_FRAMING) | 6 | wo | 0x0 | Receiver Framing Error interrupt: 0: no affect 1: enable (clears mask = 0) |
| XUARTPS_IXR_OVER (IXR_OVER) | 5 | wo | 0x0 | Receiver Overflow Error interrupt: 0: no affect 1: enable (clears mask = 0) |
| XUARTPS_IXR_TXFULL (IXR_TXFULL) | 4 | wo | 0x0 | Transmitter FIFO Full interrupt: 0: no affect 1: enable (clears mask = 0) |
| XUARTPS_IXR_TXEMPT Y (IXR_TXEMPTY) | 3 | wo | 0x0 | Transmitter FIFO Empty interrupt: 0: disable 1: enable |
| XUARTPS_IXR_RXFULL (IXR_RXFULL) | 2 | wo | 0x0 | Receiver FIFO Full interrupt: 0: no affect 1: enable (clears mask = 0) |
| XUARTPS_IXR_RXEMPT Y (IXR_RXEMPTY) | 1 | wo | 0x0 | Receiver FIFO Empty interrupt: 0: no affect 1: enable (clears mask = 0) |
| XUARTPS_IXR_RXOVR (IXR_RXOVR) | 0 | wo | 0x0 | Receiver FIFO Trigger interrupt: 0: no affect 1: enable (clears mask = 0) |

Register ([UART](#)) XUARTPS_IDR_OFFSET

| | |
|------------------|---------------------------------------|
| Name | XUARTPS_IDR_OFFSET |
| Software Name | IDR |
| Relative Address | 0x0000000C |
| Absolute Address | uart0: 0xE000000C uart1: 0xE00100C |
| Width | 32 bits |
| Access Type | mixed |
| Reset Value | 0x00000000 |
| Description | Interrupt Disable Register |

Register XUARTPS_IDR_OFFSET Details

This write only register is used to disable interrupts. When any bit is written high, the corresponding interrupt is disabled. Writing a low to any bit has no effect.

| Field Name | Bits | Type | Reset Value | Description |
|--|-------|------|-------------|---|
| reserved | 31:13 | ro | 0x0 | Reserved, read as zero, ignored on write. |
| TOVR | 12 | wo | 0x0 | Transmitter FIFO Overflow interrupt: 0: no affect 1: disable (sets mask = 1) |
| TNFUL | 11 | wo | 0x0 | Transmitter FIFO Nearly Full interrupt: 0: no affect 1: disable (sets mask = 1) |
| TTRIG | 10 | wo | 0x0 | Transmitter FIFO Trigger interrupt: 0: no affect 1: disable (sets mask = 1) |
| XUARTPS_IXR_DMS (IXR_DMS) | 9 | wo | 0x0 | Delta Modem Status Indicator interrupt: 0: no affect 1: disable (sets mask = 1) |
| XUARTPS_IXR_TOUT (IXR_TOUT) | 8 | wo | 0x0 | Receiver Timeout Error interrupt: 0: no affect 1: disable (sets mask = 1) |
| XUARTPS_IXR_PARITY (IXR_PARITY) | 7 | wo | 0x0 | Receiver Parity Error interrupt: 0: no affect 1: disable (sets mask = 1) |
| XUARTPS_IXR_FRAMIN G (IXR_FRAMING) | 6 | wo | 0x0 | Receiver Framing Error interrupt: 0: no affect 1: disable (sets mask = 1) |
| XUARTPS_IXR_OVER (IXR_OVER) | 5 | wo | 0x0 | Receiver Overflow Error interrupt: 0: no affect 1: disable (sets mask = 1) |

| Field Name | Bits | Type | Reset Value | Description |
|--------------------------------------|------|------|-------------|---|
| XUARTPS_IXR_TXFULL (IXR_TXFULL) | 4 | wo | 0x0 | Transmitter FIFO Full interrupt: 0: no affect 1: disable (sets mask = 1) |
| XUARTPS_IXR_TXEMPTY (IXR_TXEMPTY) | 3 | wo | 0x0 | Transmitter FIFO Empty interrupt: 0: no affect 1: disable (sets mask = 1) |
| XUARTPS_IXR_RXFULL (IXR_RXFULL) | 2 | wo | 0x0 | Receiver FIFO Full interrupt: 0: no affect 1: disable (sets mask = 1) |
| XUARTPS_IXR_RXEMPTY (IXR_RXEMPTY) | 1 | wo | 0x0 | Receiver FIFO Empty interrupt: 0: no affect 1: disable (sets mask = 1) |
| XUARTPS_IXR_RXOVR (IXR_RXOVR) | 0 | wo | 0x0 | Receiver FIFO Trigger interrupt: 0: no affect 1: disable (sets mask = 1) |

Register ([UART](#)) XUARTPS_IMR_OFFSET

| | |
|------------------|--|
| Name | XUARTPS_IMR_OFFSET |
| Software Name | IMR |
| Relative Address | 0x00000010 |
| Absolute Address | uart0: 0xE0000010 uart1: 0xE0001010 |
| Width | 32 bits |
| Access Type | ro |
| Reset Value | 0x00000000 |
| Description | Interrupt Mask Register |

Register XUARTPS_IMR_OFFSET Details

This read only register, indicates the current state of the interrupts mask. A high value indicates the interrupt is unmasked and therefore is enabled to generate an interrupt. A low value indicates the interrupt is masked and therefore is disabled from generating an interrupt.

| Field Name | Bits | Type | Reset Value | Description |
|------------|-------|------|-------------|--|
| reserved | 31:13 | ro | 0x0 | Reserved, read as zero, ignored on write. |
| TOVR | 12 | ro | 0x0 | Transmitter FIFO Overflow interrupt status: 0: interrupt is disabled 1: interrupt is enabled |
| TNFUL | 11 | ro | 0x0 | Transmitter FIFO Nearly Full interrupt mask status: 0: interrupt is disabled 1: interrupt is enabled |

| Field Name | Bits | Type | Reset Value | Description |
|--------------------------------------|------|------|-------------|--|
| TTRIG | 10 | ro | 0x0 | Transmitter FIFO Trigger interrupt mask status: 0: interrupt is disabled 1: interrupt is enabled |
| XUARTPS_IXR_DMS (IXR_DMS) | 9 | ro | 0x0 | Delta Modem Status Indicator interrupt mask status: 0: interrupt is disabled 1: interrupt is enabled |
| XUARTPS_IXR_TOUT (IXR_TOUT) | 8 | ro | 0x0 | Receiver Timeout Error interrupt mask status: 0: interrupt is disabled 1: interrupt is enabled |
| XUARTPS_IXR_PARITY (IXR_PARITY) | 7 | ro | 0x0 | Receiver Parity Error interrupt mask status: 0: interrupt is disabled 1: interrupt is enabled |
| XUARTPS_IXR_FRAMING (IXR_FRAMING) | 6 | ro | 0x0 | Receiver Framing Error interrupt mask status: 0: interrupt is disabled 1: interrupt is enabled |
| XUARTPS_IXR_OVER (IXR_OVER) | 5 | ro | 0x0 | Receiver Overflow Error interrupt mask status: 0: interrupt is disabled 1: interrupt is enabled |
| XUARTPS_IXR_TXFULL (IXR_TXFULL) | 4 | ro | 0x0 | Transmitter FIFO Full interrupt mask status: 0: interrupt is disabled 1: interrupt is enabled |
| XUARTPS_IXR_TXEMPTY (IXR_TXEMPTY) | 3 | ro | 0x0 | Transmitter FIFO Empty interrupt mask status: 0: interrupt is disabled 1: interrupt is enabled |
| XUARTPS_IXR_RXFULL (IXR_RXFULL) | 2 | ro | 0x0 | Receiver FIFO Full interrupt mask status: 0: interrupt is disabled 1: interrupt is enabled |
| XUARTPS_IXR_RXEMPTY (IXR_RXEMPTY) | 1 | ro | 0x0 | Receiver FIFO Empty interrupt mask status: 0: interrupt is disabled 1: interrupt is enabled |
| XUARTPS_IXR_RXOVR (IXR_RXOVR) | 0 | ro | 0x0 | Receiver FIFO Trigger interrupt mask status: 0: interrupt is disabled 1: interrupt is enabled |

Register ([UART](#)) XUARTPS_ISR_OFFSET

| | |
|------------------|--|
| Name | XUARTPS_ISR_OFFSET |
| Software Name | ISR |
| Relative Address | 0x00000014 |
| Absolute Address | uart0: 0xE0000014 uart1: 0xE0001014 |
| Width | 32 bits |

Access Type wtc
 Reset Value 0x00000000
 Description Channel Interrupt Status Register

Register XUARTPS_ISR_OFFSET Details

The Channel Interrupt Status register indicates any interrupt events that have occurred since this register was last cleared. The bits in this register are compared with the interrupt mask and used to assert the interrupt output.

This register indicated the unmasked status, allowing software to implement a polling method of interrupt handling.

| Field Name | Bits | Type | Reset Value | Description |
|------------|-------|------|-------------|--|
| reserved | 31:13 | wtc | 0x0 | Reserved, read as zero, ignored on write. |
| TOVR | 12 | wtc | 0x0 | Transmitter FIFO Overflow interrupt mask status: This event is triggered whenever a new word is pushed into the transmit FIFO when there is not enough room for all of the data. This will be set as a result of any write when the TFUL flag in Channel_sts_reg0 is already set, or a double byte write when the TNFUL flag in Channel_sts_reg0 is already set. 0: no interrupt occurred 1: interrupt occurred |
| TNFUL | 11 | wtc | 0x0 | Transmitter FIFO Nearly Full interrupt mask status: This event is triggered whenever a new word is pushed into the transmit FIFO causing the fill level to be such that there is not enough space for a further write of the number of bytes currently specified in the WSIZE bits in the Mode register. If this further write were currently attempted it would cause an overflow. Note that when WSIZE is 00, this assumes that a two byte write would be attempted and hence a single byte write is still possible without overflow by driving byte_sel low for the write. 0: no interrupt occurred 1: interrupt occurred |
| TTRIG | 10 | wtc | 0x0 | Transmitter FIFO Trigger interrupt mask status. This event is triggered whenever a new word is pushed into the transmit FIFO causing the fill level to become equal to the value defined by TTRIG. 0: no interrupt occurred 1: interrupt occurred |

| Field Name | Bits | Type | Reset Value | Description |
|--------------------------------------|------|------|-------------|--|
| XUARTPS_IXR_DMS (IXR_DMS) | 9 | wtc | 0x0 | Delta Modem Status Indicator interrupt mask status: This event is triggered whenever the DCTS, DDSR, TERI, or DDCD in the modem status register are being set. 0: no interrupt occurred 1: interrupt occurred |
| XUARTPS_IXR_TOUT (IXR_TOUT) | 8 | wtc | 0x0 | Receiver Timeout Error interrupt mask status: This event is triggered whenever the receiver timeout counter has expired due to a long idle condition. 0: no interrupt occurred 1: interrupt occurred |
| XUARTPS_IXR_PARITY (IXR_PARITY) | 7 | wtc | 0x0 | Receiver Parity Error interrupt mask status: This event is triggered whenever the received parity bit does not match the expected value. 0: no interrupt occurred 1: interrupt occurred |
| XUARTPS_IXR_FRAMING (IXR_FRAMING) | 6 | wtc | 0x0 | Receiver Framing Error interrupt mask status: This event is triggered whenever the receiver fails to detect a valid stop bit. 0: no interrupt occurred 1: interrupt occurred |
| XUARTPS_IXR_OVER (IXR_OVER) | 5 | wtc | 0x0 | Receiver Overflow Error interrupt mask status: This event is triggered whenever the contents of the receiver shift register have not yet been transferred to the receiver FIFO and a new start bit is detected. This may be due to the FIFO being full, or due to excessive clock boundary delays. 0: no interrupt occurred 1: interrupt occurred |
| XUARTPS_IXR_TXFULL (IXR_TXFULL) | 4 | wtc | 0x0 | Transmitter FIFO Full interrupt mask status: This event is triggered whenever a new word is inserted into the transmit FIFO causing it to go from a non-full condition to a full condition. 0: no interrupt occurred 1: interrupt occurred |
| XUARTPS_IXR_TXEMPTY (IXR_TXEMPTY) | 3 | wtc | 0x0 | Transmitter FIFO Empty interrupt mask status: This event is triggered whenever the final word is removed from the transmit FIFO. 0: no interrupt occurred 1: interrupt occurred |
| XUARTPS_IXR_RXFULL (IXR_RXFULL) | 2 | wtc | 0x0 | Receiver FIFO Full interrupt mask status: This event is triggered whenever a new word is inserted into the receive FIFO causing it to go from a non-full condition to a full condition. 0: no interrupt occurred 1: interrupt occurred |

| Field Name | Bits | Type | Reset Value | Description |
|--------------------------------------|------|------|-------------|--|
| XUARTPS_IXR_RXEMPTY (IXR_RXEMPTY) | 1 | wtc | 0x0 | Receiver FIFO Empty interrupt mask status: This event is triggered upon exit of the final word from the receive FIFO. 0: no interrupt occurred 1: interrupt occurred |
| XUARTPS_IXR_RXOVR (IXR_RXOVR) | 0 | wtc | 0x0 | Receiver FIFO Trigger interrupt mask status: This event is triggered whenever a new word is inserted into the receive FIFO . 0: no interrupt occurred 1: interrupt occurred |

Register ([UART](#)) XUARTPS_BAUDGEN_OFFSET

| | |
|------------------|--|
| Name | XUARTPS_BAUDGEN_OFFSET |
| Software Name | BAUDGEN |
| Relative Address | 0x00000018 |
| Absolute Address | uart0: 0xE0000018 uart1: 0xE0001018 |
| Width | 32 bits |
| Access Type | mixed |
| Reset Value | 0x0000028B |
| Description | Baud Rate Generator Register. |

Register XUARTPS_BAUDGEN_OFFSET Details

The read/write baud rate generator control register controls the amount by which to divide sel_clk to generate the bit rate clock enable, baud_sample.

| Field Name | Bits | Type | Reset Value | Description |
|------------|-------|------|-------------|--|
| reserved | 31:16 | ro | 0x0 | Reserved, read as zero, ignored on write. |
| CD | 15:0 | rw | 0x28B | Baud Rate Clock Divisor Value: 0: Disables baud_sample 1: Clock divisor bypass (baud_sample = sel_clk) 2 - 65535: baud_sample |

Register ([UART](#)) XUARTPS_RXTOUT_OFFSET

| | |
|------------------|-----------------------|
| Name | XUARTPS_RXTOUT_OFFSET |
| Software Name | RXTOUT |
| Relative Address | 0x0000001C |

| | |
|------------------|--|
| Absolute Address | uart0: 0xE000001C uart1: 0xE000101C |
| Width | 32 bits |
| Access Type | mixed |
| Reset Value | 0x00000000 |
| Description | Receiver Timeout Register |

Register XUARTPS_RXTOUT_OFFSET Details

The read/write Receiver Timeout register is used to enable the UART to detect an idle condition on the receiver data line. The timeout value (RTO) indicates the maximum delay for which the UART should wait for a new character to arrive before issuing a timeout interrupt.

| Field Name | Bits | Type | Reset Value | Description |
|------------|------|------|-------------|---|
| reserved | 31:8 | ro | 0x0 | Reserved, read as zero, ignored on write. |
| RTO | 7:0 | rw | 0x0 | Receiver timeout value: 0: Disables receiver timeout counter 1 - 255: Receiver timeout in number of baud_sample clocks. |

Register ([UART](#)) XUARTPS_RXWM_OFFSET

| | |
|------------------|--|
| Name | XUARTPS_RXWM_OFFSET |
| Software Name | RXWM |
| Relative Address | 0x00000020 |
| Absolute Address | uart0: 0xE0000020 uart1: 0xE0001020 |
| Width | 32 bits |
| Access Type | mixed |
| Reset Value | 0x00000020 |
| Description | Receiver FIFO Trigger Level Register |

Register XUARTPS_RXWM_OFFSET Details

The read/write Receiver FIFO Trigger Level Register is used to set the value at which the receiver FIFO triggers an interrupt event.

| Field Name | Bits | Type | Reset Value | Description |
|------------|------|------|-------------|---|
| reserved | 31:6 | ro | 0x0 | Reserved, read as zero, ignored on write. |
| RTRIG | 5:0 | rw | 0x20 | Receiver FIFO trigger level value: 0: Disables receiver FIFO trigger level function 1 - 63: Trigger set when receiver FIFO fills to RTRIG bytes |

Register ([UART](#)) XUARTPS_MODEMCR_OFFSET

| | |
|------------------|---------------------------------------|
| Name | XUARTPS_MODEMCR_OFFSET |
| Software Name | MODEMCR |
| Relative Address | 0x00000024 |
| Absolute Address | uart0: 0xE0000024 uart1: 0xE001024 |
| Width | 32 bits |
| Access Type | mixed |
| Reset Value | 0x00000000 |
| Description | Modem Control Register |

Register XUARTPS_MODEMCR_OFFSET Details

The read/write Modem Control register controls the interface with the modem or data set, or a peripheral device emulating a modem.

| Field Name | Bits | Type | Reset Value | Description |
|---------------------------|------|------|-------------|--|
| reserved | 31:6 | ro | 0x0 | Reserved, read as zero, ignored on write. |
| XUARTPS_MODEMCR_FCM (FCM) | 5 | rw | 0x0 | Automatic flow control mode: 0: disable Transmission is continuous regardless of the value of the EMIOUARTxCTSN input, and the EMIOUARTxRTSN output is driven completely under software control. 1: enable Transmission will only occur when the EMIOUARTxCTSN input is asserted low, and the EMIOUARTxRTSN output is driven using a compare of the RX FIFO fill level to the programmed FDEL value. |
| reserved | 4:2 | ro | 0x0 | Reserved, read as zero, ignored on write. |
| XUARTPS_MODEMCR_RTS (RTS) | 1 | rw | 0x0 | Request to send output control: This bit is ignored if automatic flow control mode is enabled by FCM being high. If FCM is low, the value of this bit is inverted when applied to the EMIOUARTxRTSN output. 0: EMIOUARTxRTSN output forced to logic 1 1: EMIOUARTxRTSN output forced to logic 0 |
| XUARTPS_MODEMCR_DTR (DTR) | 0 | rw | 0x0 | Data Terminal Ready: The value of this bit is inverted when applied to the EMIOUARTxDTRN output. 0: EMIOUARTxDTRN output forced to logic 1 1: EMIOUARTxDTRN output forced to logic 0 |

Register ([UART](#)) XUARTPS_MODEMSR_OFFSET

| | |
|------------------|---------------------------------------|
| Name | XUARTPS_MODEMSR_OFFSET |
| Software Name | MODEMSR |
| Relative Address | 0x00000028 |
| Absolute Address | uart0: 0xE0000028 uart1: 0xE001028 |
| Width | 32 bits |
| Access Type | mixed |
| Reset Value | x |
| Description | Modem Status Register |

Register XUARTPS_MODEMSR_OFFSET Details

The Modem Status register indicates the current state of the control lines from the modem, or peripheral device, to the CPU. In addition, four bits of the modem status register provide change of state or delta information. These bits are set to logic 1 whenever a control input from the modem changes state. In the default configuration, these delta bits are all cleared simultaneously when this register is read. This may be parameterised at compile time such that a one must be written to a bit in order to clear it and a read has no effect.

| Field Name | Bits | Type | Reset Value | Description |
|--------------------------------|------|------|-------------|---|
| reserved | 31:9 | ro | x | Reserved, read as zero, ignored on write. |
| XUARTPS_MODEMSR_FCMS (FCMS) | 8 | rw | x | Flow Control Mode: 0: disabled 1: enabled |
| XUARTPS_MODEMSR_DCD (DCD) | 7 | ro | x | Data Carrier Detect (DCD) input signal from PL (EMIOUARTxDCDN) status: 0: input is high 1: input is low |
| XUARTPS_MODEMSR_RI (RI) | 6 | ro | x | Ring Indicator (RI) input signal from PL (EMIOUARTxRIN) status: 0: input is high 1: input is low |
| XUARTPS_MODEMSR_DSR (DSR) | 5 | ro | x | Data Set Ready (DSR) input signal from PL (EMIOUARTxDSRN) status: 0: input is high 1: input is low |
| XUARTPS_MODEMSR_CTS (CTS) | 4 | ro | x | Clear to Send (CTS) input signal from PL (EMIOUARTxCTSN) status: 0: input is high 1: input is low |

| Field Name | Bits | Type | Reset Value | Description |
|--|------|------|-------------|---|
| XUARTPS_MEDEMSR_DCDX (MEDEMSR_DCDX) | 3 | wtc | x | Delta Data Carrier Detect status: Indicates a change in state of the EMIOUARTxDCDN input since this bit was last cleared. 0: No change has occurred 1: Change has occurred |
| XUARTPS_MEDEMSR_RIX (MEDEMSR_RIX) | 2 | wtc | x | Trailing Edge Ring Indicator status: Indicates that the EMIOUARTxRIN input has change from high to low state since this bit was last cleared. 0: No trailing edge has occurred 1: Trailing edge has occurred |
| XUARTPS_MEDEMSR_DSX (MEDEMSR_DSX) | 1 | wtc | x | Delta Data Set Ready status: Indicates a change in state of the EMIOUARTxDSRN input since this bit was last cleared. 0: No change has occurred 1: Change has occurred |
| XUARTPS_MEDEMSR_CTSX (MEDEMSR_CTSX) | 0 | wtc | x | Delta Clear To Send status: Indicates a change in state of the EMIOUARTxCTSN input since this bit was last cleared. 0: No change has occurred 1: Change has occurred |

Register ([UART](#)) XUARTPS_SR_OFFSET

| | |
|------------------|--|
| Name | XUARTPS_SR_OFFSET |
| Software Name | SR |
| Relative Address | 0x0000002C |
| Absolute Address | uart0: 0xE000002C uart1: 0xE000102C |
| Width | 32 bits |
| Access Type | ro |
| Reset Value | 0x00000000 |
| Description | Channel Status Register |

Register XUARTPS_SR_OFFSET Details

The read only Channel Status register is provided to enable the continuous monitoring of the raw unmasked status information of the UART design.

Bits [4:0] and [14:10] are not latched and provide raw status of the FIFO flags, such that if the FIFO level changes these bits are updated immediately.

| Field Name | Bits | Type | Reset Value | Description |
|------------------------------|-------|------|-------------|---|
| reserved | 31:15 | ro | 0x0 | Reserved, read as zero, ignored on write. |
| TNFUL | 14 | ro | 0x0 | Transmitter FIFO Nearly Full continuous status: This indicates that there is not enough space for the number of bytes currently specified in the WSIZE bits in the Mode register. If a write were currently attempted it would cause an overflow. Note that when WSIZE is 00, this assumes that a two byte write would be attempted and hence a single byte write is still possible without overflow by driving byte_sel low for the write. 0: More than one byte is unused in the Tx FIFO 1: Only one byte is free in the Tx FIFO |
| TTRIG | 13 | ro | 0x0 | Transmitter FIFO Trigger continuous status: 0: Tx FIFO fill level is less than TTRIG 1: Tx FIFO fill level is greater than or equal to TTRIG |
| XUARTPS_SR_FLOWDEL (FLOWDEL) | 12 | ro | 0x0 | Receiver flow delay trigger continuous status: 0: Rx FIFO fill level is less than FDEL 1: Rx FIFO fill level is greater than or equal to FDEL |
| XUARTPS_SR_TACTIVE (TACTIVE) | 11 | ro | 0x0 | Transmitter state machine active status: 0: inactive state 1: active state |
| XUARTPS_SR_RACTIVE (RACTIVE) | 10 | ro | 0x0 | Receiver state machine active status: 0: inactive state 1: active state |
| reserved | 9 | ro | 0x0 | Reserved. Do not modify. |
| reserved | 8 | ro | 0x0 | Reserved. Do not modify. |
| reserved | 7 | ro | 0x0 | Reserved. Do not modify. |
| reserved | 6 | ro | 0x0 | Reserved. Do not modify. |
| reserved | 5 | ro | 0x0 | Reserved. Do not modify. |
| XUARTPS_SR_TXFULL (TXFULL) | 4 | ro | 0x0 | Transmitter FIFO Full continuous status: 0: Tx FIFO is not full 1: Tx FIFO is full |
| XUARTPS_SR_TXEMPTY (TXEMPTY) | 3 | ro | 0x0 | Transmitter FIFO Empty continuous status: 0: Tx FIFO is not empty 1: Tx FIFO is empty |
| XUARTPS_SR_RXFULL (RXFULL) | 2 | ro | 0x0 | Receiver FIFO Full continuous status: 1: Rx FIFO is full 0: Rx FIFO is not full |

| Field Name | Bits | Type | Reset Value | Description |
|------------------------------|------|------|-------------|---|
| XUARTPS_SR_RXEMPTY (RXEMPTY) | 1 | ro | 0x0 | Receiver FIFO Full continuous status: 0: Rx FIFO is not empty 1: Rx FIFO is empty |
| XUARTPS_SR_RXOVR (RXOVR) | 0 | ro | 0x0 | Receiver FIFO Trigger continuous status: 0: Rx FIFO fill level is less than RTRIG 1: Rx FIFO fill level is greater than or equal to RTRIG |

Register (UART) XUARTPS_FIFO_OFFSET

| | |
|------------------|--|
| Name | XUARTPS_FIFO_OFFSET |
| Software Name | FIFO |
| Relative Address | 0x00000030 |
| Absolute Address | uart0: 0xE0000030 uart1: 0xE0001030 |
| Width | 32 bits |
| Access Type | mixed |
| Reset Value | 0x00000000 |
| Description | Transmit and Receive FIFO |

Register XUARTPS_FIFO_OFFSET Details

| Field Name | Bits | Type | Reset Value | Description |
|------------|------|------|-------------|---|
| reserved | 31:8 | ro | 0x0 | Reserved, read as zero, ignored on write. |
| FIFO | 7:0 | rw | 0x0 | Operates as Tx FIFO and Rx FIFO. |

Register (UART) Baud_rate_divider_reg0

| | |
|------------------|--|
| Name | Baud_rate_divider_reg0 |
| Relative Address | 0x00000034 |
| Absolute Address | uart0: 0xE0000034 uart1: 0xE0001034 |
| Width | 32 bits |
| Access Type | mixed |
| Reset Value | 0x0000000F |
| Description | Baud Rate Divider Register |

Register Baud_rate_divider_reg0 Details

The baud rate divider register controls how much baud_sample is divided by to generate the baud rate clock enables, baud_rx_rate and baud_tx_rate.

| Field Name | Bits | Type | Reset Value | Description |
|------------|------|------|-------------|--|
| reserved | 31:8 | ro | 0x0 | Reserved, read as zero, ignored on write. |
| BDIV | 7:0 | rw | 0xF | Baud rate divider value: 0 - 3: ignored 4 - 255: Baud rate |

Register (UART) Flow_delay_reg0

| | |
|------------------|--|
| Name | Flow_delay_reg0 |
| Relative Address | 0x00000038 |
| Absolute Address | uart0: 0xE0000038 uart1: 0xE0001038 |
| Width | 32 bits |
| Access Type | mixed |
| Reset Value | 0x00000000 |
| Description | Flow Control Delay Register |

Register Flow_delay_reg0 Details

The Flow Control Delay register is only used if automatic flow control mode is enabled in the FCM field in the Modem Control register. When automatic flow control mode is enabled, this register specifies the receiver FIFO level at which the EMIOUARTxRTSN output is de-asserted. The EMIOUARTxRTSN output is only asserted again once the fill level drops to below four less than FDEL.

| Field Name | Bits | Type | Reset Value | Description |
|------------|------|------|-------------|--|
| reserved | 31:6 | ro | 0x0 | Reserved, read as zero, ignored on write. |
| FDEL | 5:0 | rw | 0x0 | RxFIFO trigger level for Ready To Send (RTS) output signal (EMIOUARTxRTSN) de-assertion: 0 - 3: Flow delay triggering is disabled, since minimum 4 word hysteresis cannot be satisfied. 4 to 65535: EMIOUARTxRTSN is driven high when Rx FIFO fill level equals FDEL |

Register (UART) Tx_FIFO_trigger_level0

| | |
|------------------|------------------------|
| Name | Tx_FIFO_trigger_level0 |
| Relative Address | 0x00000044 |

| | |
|------------------|---|
| Absolute Address | uart0: 0xE0000044 uart1: 0xE0001044 |
| Width | 32 bits |
| Access Type | mixed |
| Reset Value | 0x00000020 |
| Description | Transmitter FIFO Trigger Level Register |

Register Tx_FIFO_trigger_level0 Details

The read/write Transmitter FIFO Trigger Level Register is used to set the value at which the transmitter FIFO triggers an interrupt event.

| Field Name | Bits | Type | Reset Value | Description |
|------------|------|------|-------------|--|
| reserved | 31:6 | ro | 0x0 | Reserved, read as zero, ignored on write. |
| TTRIG | 5:0 | rw | 0x20 | Transmitter FIFO trigger level: 0: Disables transmitter FIFO trigger level function 1 - 63: Trigger set when transmitter FIFO fills to TTRIG bytes |

B.34 USB Controller (usb)

| | |
|---------------|------------------------------------|
| Module Name | USB Controller (usb) |
| Software Name | XUSBPS |
| Base Address | 0xE0002000 usb0 0xE0003000 usb1 |
| Description | USB controller registers |
| Vendor Info | Synopsys |

Register Summary

| Register Name | Address | Width | Type | Reset Value | Description |
|--------------------------------------|------------|-------|-------|-------------|--|
| ID | 0x00000000 | 32 | ro | 0xE441FA05 | IP version and revision, read-only |
| HWGENERAL | 0x00000004 | 12 | ro | 0x00000083 | Misc IP config constants, read-only |
| HWHOST | 0x00000008 | 32 | ro | 0x10020001 | Host Mode IP config constants, read-only |
| HWDEVICE | 0x0000000C | 6 | ro | 0x00000019 | Device Mode IP config constants, read-only |
| HWTXBUF | 0x00000010 | 32 | ro | 0x80060A10 | TxBuffer IP config constants, read-only |
| HWRXBUF | 0x00000014 | 32 | ro | 0x00000A10 | IP constants, RX buffer constants, read-only |
| GPTIMER0LD | 0x00000080 | 24 | rw | 0x00000000 | GP Timer 0 Load Value. |
| GPTIMER0CTRL | 0x00000084 | 32 | mixed | 0x00000000 | GP Timer 1 Control. |
| GPTIMER1LD | 0x00000088 | 24 | rw | 0x00000000 | GP Timer 1 Load Value |
| GPTIMER1CTRL | 0x0000008C | 32 | mixed | 0x00000000 | GP Timer 1 Control |
| SBUSCFG | 0x00000090 | 3 | rw | 0x00000003 | DMA Master AHB Burst Mode |
| CAPLENGTH_HCIVERSION | 0x00000100 | 32 | ro | 0x01000040 | EHCI Addr Space and HCI constants, read-only |
| HCSPARAMS | 0x00000104 | 28 | ro | 0x00010011 | TT counts and EHCI HCS constants, read-only |
| HCCPARAMS | 0x00000108 | 16 | ro | 0x00000006 | EHCI Host Configuration Constants. |
| DCVERSION | 0x00000120 | 16 | ro | 0x00000001 | Device Controller Interface Version. |
| DCCPARAMS | 0x00000124 | 9 | ro | 0x0000018C | EHCI, Device, and Endpoint Capabilities. |
| XUSBPS_CMD_OFFSET | 0x00000140 | 24 | mixed | 0x00080000 | USB Commands (EHCI extended) |

| Register Name | Address | Width | Type | Reset Value | Description |
|---|------------|-------|-------|-------------|--|
| XUSBPS_ISR_OFFSET | 0x00000144 | 26 | mixed | 0x00000000 | Interrupt/Raw Status (EHCI extended) (Host/Device) |
| XUSBPS_IER_OFFSET | 0x00000148 | 26 | mixed | 0x00000000 | Interrupts and Enables |
| XUSBPS_FRAME_OFFSET | 0x0000014C | 14 | rw | 0x00000000 | Frame List Index |
| XUSBPS_LISTBASE_OFFSET | 0x00000154 | 32 | mixed | 0x00000000 | Host/Device Address dual-use |
| XUSBPS_ASYNCLISTADDR_OFFSET | 0x00000158 | 32 | mixed | 0x00000000 | Host/Device dual-use |
| XUSBPS_TTCTRL_OFFSET | 0x0000015C | 32 | mixed | 0x00000000 | TT Control |
| XUSBPS_BURSTSIZE_OFFSET | 0x00000160 | 17 | rw | 0x00001010 | Burst Size |
| XUSBPS_TXFILL_OFFSET | 0x00000164 | 22 | mixed | 0x00000000 | TxFIFO Fill Tuning |
| TXTTFILLTUNING | 0x00000168 | 13 | mixed | 0x00000000 | TT TX latency FIFO |
| IC_USB | 0x0000016C | 32 | mixed | 0x00000000 | Low and Fast Speed Control constants |
| XUSBPS_ULPIVIEW_OFFSET | 0x00000170 | 32 | mixed | 0x08000000 | ULPI Viewport |
| XUSBPS_EPNAKISR_OFFSET | 0x00000178 | 32 | wtc | 0x00000000 | Endpoint NAK (Device mode) |
| XUSBPS_EPNAKIER_OFFSET | 0x0000017C | 32 | rw | 0x00000000 | Endpoint NAK (Device mode) |
| CONFIGFLAG | 0x00000180 | 32 | ro | 0x00000001 | reserved |
| XUSBPS_PORTSCR1_OFFSET | 0x00000184 | 32 | mixed | 0x8C000004 | Port Status & Control |
| XUSBPS_OTGCSR_OFFSET | 0x000001A4 | 32 | mixed | 0x00001020 | OTG Status and Control |
| XUSBPS_MODE_OFFSET | 0x000001A8 | 32 | mixed | 0x00000000 | USB Mode Selection |
| XUSBPS_EPSTAT_OFFSET | 0x000001AC | 16 | wtc | 0x00000000 | Endpoint Status Setup (Device mode) |
| XUSBPS_EPPRIME_OFFSET | 0x000001B0 | 32 | wtc | 0x00000000 | Endpoint Primer (Device mode) |
| XUSBPS_EPFLUSH_OFFSET | 0x000001B4 | 32 | wtc | 0x00000000 | Endpoint Flush (Device mode) |
| XUSBPS_EPRDY_OFFSET | 0x000001B8 | 32 | ro | 0x00000000 | Endpoint Buffer Ready Status (Device mode), RO |
| XUSBPS_EPCOMPL_OFFSET | 0x000001BC | 32 | rw | 0x00000000 | Endpoint Tx Complete (Device mode) |
| XUSBPS_EPCRO_OFFSET | 0x000001C0 | 24 | mixed | 0x00800080 | Endpoint 0 (Device mode) |
| ENDPTCTRL1 | 0x000001C4 | 24 | mixed | 0x00000000 | Endpoints 1 to 11 (Device mode) |
| ENDPTCTRL2 | 0x000001C8 | 24 | mixed | 0x00000000 | Endpoints 1 to 11 (Device mode) |
| ENDPTCTRL3 | 0x000001CC | 24 | mixed | 0x00000000 | Endpoints 1 to 11 (Device mode) |

| Register Name | Address | Width | Type | Reset Value | Description |
|-----------------------------|------------|-------|-------|-------------|---------------------------------|
| ENDPTCTRL4 | 0x000001D0 | 24 | mixed | 0x00000000 | Endpoints 1 to 11 (Device mode) |
| ENDPTCTRL5 | 0x000001D4 | 24 | mixed | 0x00000000 | Endpoints 1 to 11 (Device mode) |
| ENDPTCTRL6 | 0x000001D8 | 24 | mixed | 0x00000000 | Endpoints 1 to 11 (Device mode) |
| ENDPTCTRL7 | 0x000001DC | 24 | mixed | 0x00000000 | Endpoints 1 to 11 (Device mode) |
| ENDPTCTRL8 | 0x000001E0 | 24 | mixed | 0x00000000 | Endpoints 1 to 11 (Device mode) |
| ENDPTCTRL9 | 0x000001E4 | 24 | mixed | 0x00000000 | Endpoints 1 to 11 (Device mode) |
| ENDPTCTRL10 | 0x000001E8 | 24 | mixed | 0x00000000 | Endpoints 1 to 11 (Device mode) |
| ENDPTCTRL11 | 0x000001EC | 24 | mixed | 0x00000000 | Endpoints 1 to 11 (Device mode) |

Register ([usb](#)) ID

| | |
|------------------|--------------------------------------|
| Name | ID |
| Relative Address | 0x00000000 |
| Absolute Address | usb0: 0xE0002000 usb1: 0xE0003000 |
| Width | 32 bits |
| Access Type | ro |
| Reset Value | 0xE441FA05 |
| Description | IP version and revision, read-only |

Register ID Details

IP supplier controller identification (revision and synthesized configuration). Hardwired (constant value).

| Field Name | Bits | Type | Reset Value | Description |
|------------|-------|------|-------------|---|
| CIVERSION | 31:29 | ro | 0x7 | Reserved, reads 111. |
| VERSION | 28:25 | ro | 0x2 | IP entire version code: [VERSION].[REVISION][TAG] refers to IP version 2.20a. |
| REVISION | 24:21 | ro | 0x2 | Refer to [VERSION]. |
| TAG | 20:16 | ro | 0x1 | Refer to [VERSION]. |
| reserved | 15:14 | ro | 0x3 | reserved, writes ignored. |
| NID | 13:8 | ro | 0x3A | Controller ID: Ones complement of [ID]. |
| reserved | 7:6 | ro | 0x0 | reserved, writes ignored. |
| ID | 5:0 | ro | 0x5 | Controller ID: USB controller supports HS, On-the-Go, and FS/LS. |

Register ([usb](#)) HWGENERAL

| | |
|------------------|--------------------------------------|
| Name | HWGENERAL |
| Relative Address | 0x00000004 |
| Absolute Address | usb0: 0xE0002004 usb1: 0xE0003004 |
| Width | 12 bits |
| Access Type | ro |
| Reset Value | 0x00000083 |
| Description | Misc IP config constants, read-only |

Register HWGENERAL Details

General hardware parameters provided by the IP supplier and defined by Xilinx for synthesis.

Hardwired (constant value). Bits [31:12] are reserved.

| Field Name | Bits | Type | Reset Value | Description |
|------------|-------|------|-------------|--|
| SM | 11:10 | ro | 0x0 | VUSB_HS_PHY_SERIAL constant. 0: Parallel I/O Port interface. Note: VUSB_HS_PHY_UTMI = 0 (UTMI not used) and VUSB_HS_PHY_ULPI = 1 (ULPI implemented). |
| PHYM | 9:6 | ro | 0x2 | VUSB_HS_PHY_TYPE constant. 0010: 8-bit ULPI single data rate I/O interface. |
| PHYW | 5:4 | ro | 0x0 | VUSB_HS_PHY16_8 constant. 0: 8-bit data bus |
| BWT | 3 | ro | 0x0 | reserved |
| CLKC | 2:1 | ro | 0x1 | VUSB_HS_CLOCK_CONFIGURATION constant. 1: CPU_1x clock must have a higher frequency than the UTMI clock (60 MHz). |
| RT | 0 | ro | 0x1 | VUSB_HS_RESET_TYPE constant. 1: Asynchronous Reset |

Register ([usb](#)) HWHOST

| | |
|------------------|--------------------------------------|
| Name | HWHOST |
| Relative Address | 0x00000008 |
| Absolute Address | usb0: 0xE0002008 usb1: 0xE0003008 |
| Width | 32 bits |
| Access Type | ro |
| Reset Value | 0x10020001 |

Description Host Mode IP config constants, read-only

Register HWHOST Details

| Field Name | Bits | Type | Reset Value | Description |
|------------|-------|------|-------------|---|
| TTPER | 31:24 | ro | 0x10 | VUSB_HS_TT_PERIODIC_CONTEXTS constant. 0x010: Sixteen periodic contexts in TT. |
| TTASY | 23:16 | ro | 0x2 | VUSB_HS_TT_ASYNC_CONTEXTS constant. 0x02: Two asynchronous contexts in TT. |
| | 15:4 | ro | 0x0 | reserved |
| NPORT | 3:1 | ro | 0x0 | VUSB_HS_NUM_PORT constant. 000: one downstream port supported. |
| HC | 0 | ro | 0x1 | VUSB_HS_HOST constant. 1: Host mode supported. |

Register ([usb](#)) HWDEVICE

Name HWDEVICE
 Relative Address 0x0000000C
 Absolute Address usb0: 0xE000200C
 usb1: 0xE000300C
 Width 6 bits
 Access Type ro
 Reset Value 0x00000019
 Description Device Mode IP config constants, read-only

Register HWDEVICE Details

| Field Name | Bits | Type | Reset Value | Description |
|------------|------|------|-------------|--|
| DEVEP | 5:1 | ro | 0xC | VUSB_HS_DEV_EP constant. 0x0C: Twelve endpoints supported (EP 0 to 11). |
| DC | 0 | ro | 0x1 | Controller supports Device Mode. |

Register ([usb](#)) HWTXBUF

Name HWTXBUF
 Relative Address 0x00000010
 Absolute Address usb0: 0xE0002010
 usb1: 0xE0003010
 Width 32 bits

Access Type ro
 Reset Value 0x80060A10
 Description TxBuffer IP config constants, read-only

Register HWTXBUF Details

| Field Name | Bits | Type | Reset Value | Description |
|------------|-------|------|-------------|--|
| reserved | 31 | ro | 0x1 | reserved |
| reserved | 30:24 | ro | 0x0 | reserved |
| TXCHANADD | 23:16 | ro | 0x6 | VUSB_HS_TX_CHAN_ADD constant. 0x06: Six address bits for each 64-byte endpoint TxBuffer (VBUS_HS_TX_CHAN = 64). |
| TXADD | 15:8 | ro | 0xA | VUSB_HS_TX_ADD constant. 0x0A0: 10-bit address. TxBuffer size is 768. |
| TXBURST | 7:0 | ro | 0x10 | VUSB_HS_TX_BURST constant. 0x010: 16-byte bursts on AHB by DMA engine. |

Register ([usb](#)) HWRXBUF

Name HWRXBUF
 Relative Address 0x00000014
 Absolute Address usb0: 0xE0002014
 usb1: 0xE0003014
 Width 32 bits
 Access Type ro
 Reset Value 0x00000A10
 Description IP constants, RX buffer constants, read-only

Register HWRXBUF Details

| Field Name | Bits | Type | Reset Value | Description |
|------------|-------|------|-------------|---|
| | 31:24 | ro | 0x0 | reserved |
| RXADD | 15:8 | ro | 0xA | VUSB_HS_RX_ADD constant. 0x0A0: 10-bit address. RxBuffer address size is 1024. |
| RXBURST | 7:0 | ro | 0x10 | VUSB_HS_RX_BURST constant. 0x010: 16-byte bursts on AHB by DMA engine. |

Register ([usb](#)) GPTIMEROLD

Name GPTIMEROLD

Relative Address 0x00000080
 Absolute Address usb0: 0xE0002080
 usb1: 0xE0003080
 Width 24 bits
 Access Type rw
 Reset Value 0x00000000
 Description GP Timer 0 Load Value.

Register GPTIMER0LD Details

| Field Name | Bits | Type | Reset Value | Description |
|------------|------|------|-------------|---|
| GPTLD | 23:0 | rw | 0x0 | General Purpose Timer Load Value. This field is loaded into the usb.GPTIMERxCTRL [GPTCNT] countdown timer. The value represents the time in microseconds minus 1 for the timer duration. Example: for a one millisecond timer, load 1000 - 1 = 999 (0x0003E7). Note: Maximum value is 0xFF_FFFF (16.777215 seconds). |

Register ([usb](#)) GPTIMER0CTRL

Name GPTIMER0CTRL
 Relative Address 0x00000084
 Absolute Address usb0: 0xE0002084
 usb1: 0xE0003084
 Width 32 bits
 Access Type mixed
 Reset Value 0x00000000
 Description GP Timer 1 Control.

Register GPTIMER0CTRL Details

This register contains the control for the timer and a data field, which can be queried to determine the running count value.

| Field Name | Bits | Type | Reset Value | Description |
|------------|-------|------|-------------|--|
| GPTRUN | 31 | rw | 0x0 | General Purpose Timer Enable. 0: disable. 1: enable. The setting of [GPTRUN] will not have an effect on the [GPTCNT] counter value. |
| GPTRST | 30 | wo | 0x0 | General Purpose Timer Reset. Write 1 to reload. 0: no affect. 1: Reload the [GPTCNT] with the value in [GPTLD]. |
| | 29:25 | ro | 0x0 | reserved |
| GPTMODE | 24 | rw | 0x0 | Select Countdown Timer mode. 0: One Shot (single timer countdown). The timer will count down to zero, generate an interrupt and stop until the counter is reset by software. 1: Repeat (looped countdown). The timer will count down to zero, generate an interrupt and automatically reload the counter to begin again. |
| GPTCNT | 23:0 | rw | 0x0 | General Purpose Countdown Timer. Value of the running timer. |

Register ([usb](#)) GPTIMER1LD

| | |
|------------------|--------------------------------------|
| Name | GPTIMER1LD |
| Relative Address | 0x00000088 |
| Absolute Address | usb0: 0xE0002088 usb1: 0xE0003088 |
| Width | 24 bits |
| Access Type | rw |
| Reset Value | 0x00000000 |
| Description | GP Timer 1 Load Value |

Register GPTIMER1LD Details

| Field Name | Bits | Type | Reset Value | Description |
|------------|------|------|-------------|--|
| GPTLD | 23:0 | rw | 0x0 | Refer to description for GPTIMER0LD [GPTLD]. |

Register ([usb](#)) GPTIMER1CTRL

| | |
|------------------|--------------------------------------|
| Name | GPTIMER1CTRL |
| Relative Address | 0x0000008C |
| Absolute Address | usb0: 0xE000208C usb1: 0xE000308C |

Width 32 bits
 Access Type mixed
 Reset Value 0x00000000
 Description GP Timer 1 Control

Register GPTIMER1CTRL Details

| Field Name | Bits | Type | Reset Value | Description |
|------------|-------|------|-------------|----------------------------------|
| GPTRUN | 31 | rw | 0x0 | Refer to GPTIMER0CTRL [GPTRUN]. |
| GPTRST | 30 | wo | 0x0 | Refer to GPTIMER0CTRL [GPTRST]. |
| | 29:25 | ro | 0x0 | reserved |
| GPTMODE | 24 | rw | 0x0 | Refer to GPTIMER0CTRL [GPTMODE]. |
| GPTCNT | 23:0 | rw | 0x0 | Refer to GPTIMER0CTRL [GPTCNT]. |

Register ([usb](#)) SBUSCFG

Name SBUSCFG
 Relative Address 0x00000090
 Absolute Address usb0: 0xE0002090
 usb1: 0xE0003090
 Width 3 bits
 Access Type rw
 Reset Value 0x00000003
 Description DMA Master AHB Burst Mode

Register SBUSCFG Details

| Field Name | Bits | Type | Reset Value | Description |
|------------|------|------|-------------|--|
| AHBBRST | 2:0 | rw | 0x3 | VUSB_HS_AHBBRST constant. ABH burst size: INCR16. Non-multiple transfers of INCR16 will be decomposed into INCR8, INCR4 and single transfers. |

Register ([usb](#)) CAPLENGTH_HCIVERSION

Name CAPLENGTH_HCIVERSION
 Relative Address 0x00000100
 Absolute Address usb0: 0xE0002100
 usb1: 0xE0003100
 Width 32 bits

Access Type ro
 Reset Value 0x01000040
 Description EHCI Addr Space and HCI constants, read-only

Register CAPLENGTH_HCIVERSION Details

| Field Name | Bits | Type | Reset Value | Description |
|------------|-------|------|-------------|---|
| HCIVERSION | 31:16 | ro | 0x100 | VUSB_HS_HCIVERSION constant. Host Mode (EHCI). Read-only. |
| CAPLENGTH | 15:0 | ro | 0x40 | Address space taken by the Capability registers. Host Mode (EHCI). Read-only. 0x100: add this offset to the address of the first Capability register to get the address of the first Operational register. |

Register ([usb](#)) HCSPARAMS

Name HCSPARAMS
 Relative Address 0x00000104
 Absolute Address usb0: 0xE0002104
 usb1: 0xE0003104
 Width 28 bits
 Access Type ro
 Reset Value 0x00010011
 Description TT counts and EHCI HCS constants, read-only

Register HCSPARAMS Details

Port steering logic capabilities are confined to the single host port implementation..

| Field Name | Bits | Type | Reset Value | Description |
|------------|-------|------|-------------|--|
| N_TT | 27:24 | ro | 0x0 | Transaction Translators (TT), read-only. 0: none. |
| N_PTT | 23:20 | ro | 0x0 | Number of ports per TT, read-only. 0: single host port. |
| reserved | 19:17 | ro | 0x0 | reserved. |
| PI | 16 | ro | 0x1 | Port Indicator (EHCI constant), read-only. 1: indicator available via EMIO, controlled by usb.PORTSC1 [PIC]. |
| N_CC | 15:12 | ro | 0x0 | Companion controller hardware (EHCI constant). 0: no companion controller hardware, refer to the embeded Transaction Translator (TT). |

| Field Name | Bits | Type | Reset Value | Description |
|------------|------|------|-------------|--|
| N_PCC | 11:8 | ro | 0x0 | Ports supported by each Companion Controller (EHCI constant). 0: no companion controller hardware refer to the embeded Transaction Translator (TT). |
| reserved | 7:5 | ro | 0x0 | reserved |
| PPC | 4 | ro | 0x1 | VBUS Power Control (EHCI constant). 1: signal available via EMIO, see PORTSC1 [PP]. |
| N_PORTS | 3:0 | ro | 0x1 | Downstream ports (EHCI constant). 1: one downstream port. |

Register ([usb](#)) HCCPARAMS

| | |
|------------------|--------------------------------------|
| Name | HCCPARAMS |
| Relative Address | 0x00000108 |
| Absolute Address | usb0: 0xE0002108 usb1: 0xE0003108 |
| Width | 16 bits |
| Access Type | ro |
| Reset Value | 0x00000006 |
| Description | EHCI Host Configuration Constants. |

Register HCCPARAMS Details

This register identifies multiple mode control (time-base bit functionality) addressing capability

| Field Name | Bits | Type | Reset Value | Description |
|------------|------|------|-------------|--|
| EECP | 15:8 | ro | 0x0 | EHCI |
| IST | 7:4 | ro | 0x0 | Isochronous Scheduling Threshold. This field indicates, relative to the current position of the executing host controller, where software can reliably update the isochronous schedule. |
| | 3 | ro | 0x0 | reserved |
| ASP | 2 | ro | 0x1 | Park mode capability. Read-only. Enables the controller to execute a QH transactions successively before traversing to next QH. |
| PFL | 1 | ro | 0x1 | Programmable Frame List sizes (Host mode). Software can specify the size of the frame list for the periodic schedule. Configure the size using the usb.USBCMD [FS2] [FS0] Frame List Size field: 8, 16, 32, 512, 1024. |
| ADC | 0 | ro | 0x0 | 0: 32-bit system memory address. |

Register ([usb](#)) DCIVERSION

| | |
|------------------|--------------------------------------|
| Name | DCIVERSION |
| Relative Address | 0x00000120 |
| Absolute Address | usb0: 0xE0002120 usb1: 0xE0003120 |
| Width | 16 bits |
| Access Type | ro |
| Reset Value | 0x00000001 |
| Description | Device Controller Interface Version. |

Register DCIVERSION Details

| Field Name | Bits | Type | Reset Value | Description |
|------------|------|------|-------------|--|
| DCIVERSION | 15:0 | ro | 0x1 | DCIVERSION is a BCD encoded two-byte register for Device Controller Interface Version. The upper byte indicates a major revision and the lower byte is the minor revision. |

Register ([usb](#)) DCCPARAMS

| | |
|------------------|--|
| Name | DCCPARAMS |
| Relative Address | 0x00000124 |
| Absolute Address | usb0: 0xE0002124 usb1: 0xE0003124 |
| Width | 9 bits |
| Access Type | ro |
| Reset Value | 0x0000018C |
| Description | EHCI, Device, and Endpoint Capabilities. |

Register DCCPARAMS Details

Host and device mode capability.

| Field Name | Bits | Type | Reset Value | Description |
|------------|------|------|-------------|---|
| HC | 8 | ro | 0x1 | 1: the controller supports EHCI compatible mode. |
| DC | 7 | ro | 0x1 | 1: the controller supports Device mode. |
| | 6:5 | ro | 0x0 | reserved |
| DEN | 4:0 | ro | 0xC | Number of endpoints supported in Device mode. 1100: 12 endpoints; control EP0 plus EP {11:1}. |

Register ([usb](#)) XUSBPS_CMD_OFFSET

| | |
|------------------|--------------------------------------|
| Name | XUSBPS_CMD_OFFSET |
| Software Name | CMD |
| Relative Address | 0x00000140 |
| Absolute Address | usb0: 0xE0002140 usb1: 0xE0003140 |
| Width | 24 bits |
| Access Type | mixed |
| Reset Value | 0x00080000 |
| Description | USB Commands (EHCI extended) |

Register XUSBPS_CMD_OFFSET Details

The serial bus host/device controller executes the command indicated in this register

| Field Name | Bits | Type | Reset Value | Description |
|--------------------------------------|-------|------|-------------|--|
| XUSBPS_CMD_ITC_MAS K (ITC) | 23:16 | rw | 0x8 | Interrupt Threshold Control (EHCI) (Host and mode). Program the maximum rate at which the host controller will issue an interrupt. 0x00: Immediate 0x01: 1 micro-frame. 0x02: 2 micro-frames. 0x04: 4 micro-frames. 0x08: 8 micro-frames. (1 ms) 0x10: 16 micro-frames. 0x20: 32 micro-frames. 0x40: 64 micro-frames. others: reserved. |
| XUSBPS_CMD_FS2_MA SK (FS2) | 15 | rw | 0x0 | MSB bit of Frame List Size. Refer to [FS0] bit field for description. |
| XUSBPS_CMD_ATDTW_ MASK (ATDTW) | 14 | rw | 0x0 | Add dTD TripWire (Host extended). This bit is used as a semaphore to ensure the proper addition of a new dTD to an active (primed) endpoint's linked list. |
| XUSBPS_CMD_SUTW_ MASK (SUTW) | 13 | rw | 0x0 | Setup TripWire (Device mode). This semaphore is between the DCD and the hardware for extracting setup data from QH with out any corruption. Refer to the chapter text for usage. |
| reserved | 12 | ro | 0x0 | reserved |

| Field Name | Bits | Type | Reset Value | Description |
|------------------------------------|------|------|-------------|--|
| XUSBPS_CMD_ASPE_M ASK (ASPE) | 11 | rw | 0x0 | Asynchronous Schedule Park Mode Enable (EHCI). This bit enables/disables the Asynchronous Schedule Park Mode if Asynchronous Park Capability bit in HCCPARAMS is one. Otherwise this bit is zero and Park Mode is disabled. |
| reserved | 10 | ro | 0x0 | reserved |
| XUSBPS_CMD_ASP_MA SK (ASP) | 9:8 | rw | 0x0 | Asynchronous Schudule Park Capability is supported (EHCI). The default is 3. Use any value between 1 and 3. The value 3 gives the maximum throughput in terms of number endpoint transactions compared to 1 or 2. |
| LR | 7 | ro | 0x0 | Light Host/Device Controller Reset (EHCI). 0: not supported. |
| XUSBPS_CMD_IAA_MA SK (IAA) | 6 | rw | 0x0 | Interrupt on Async Schedule Advance Doorbell (EHCI). 0: no affect 1: ring the doorbell when the controller advances the asynchronous schedule. |
| XUSBPS_CMD_ASE_MA SK (ASE) | 5 | rw | 0x0 | Asynchronous Schedule Enable (EHCI) (Host mode). 0: disable Async Schedule processing (the current DMA transactions finishes). 1: enable Async Schedule processing (the memory address for the async schedule is programmed into usb.ASYNCLISTADDR). |
| XUSBPS_CMD_PSE_MA SK (PSE) | 4 | rw | 0x0 | Periodic Schedule Enable (EHCI) (Host mode). 0: disable Periodic Schedule processing 1: enable Periodic Schedule Note: The memory address for the periodic schedule is programmed into usb.PERIODICLISTBASE. |
| XUSBPS_CMD_FS01_M ASK (FS01) | 3:2 | rw | 0x0 | Frame List Size (EHCI extended). usb.USBCMD [15] [3] [2] bits: 000: 1024 elements (4096 bytes) 001: 512 elements (2048 bytes) ... 111: 8 elements (32 bytes) |

| Field Name | Bits | Type | Reset Value | Description |
|---------------------------|------|------|-------------|--|
| XUSBPS_CMD_RST_MASK (RST) | 1 | rw | 0x0 | Controller Reset and Status (ECHI) (Host and Device mode). |
| XUSBPS_CMD_RS_MASK (RS) | 0 | rw | 0x0 | Run/Stop (ECHI) (Host and Device modes). Device Mode: 0: the controller halts activity after the current packet transfer is complete. 1: the controller proceeds to execute the periodic and async schedules. Host Mode: 0: TBD 1: TBD |

Register ([usb](#)) XUSBPS_ISR_OFFSET

| | |
|------------------|--|
| Name | XUSBPS_ISR_OFFSET |
| Software Name | ISR |
| Relative Address | 0x00000144 |
| Absolute Address | usb0: 0xE0002144 usb1: 0xE0003144 |
| Width | 26 bits |
| Access Type | mixed |
| Reset Value | 0x00000000 |
| Description | Interrupt/Raw Status (EHCI extended) (Host/Device) |

Register XUSBPS_ISR_OFFSET Details

Various USB bus and port interrupts, controller state status, controller event and general purpose timer interrupts.

| Field Name | Bits | Type | Reset Value | Description |
|-------------------------------|-------|------|-------------|---|
| XUSBPS_IXR_TI1_MASK (IXR_TI1) | 25 | rw | 0x0 | GP timer 1 raw interrupt (Host/Device). Refer to [TI0] bit description. |
| XUSBPS_IXR_TI0_MASK (IXR_TI0) | 24 | rw | 0x0 | GP timer 0 raw interrupt status (Host/Device). Read -- 0: inactive. 1: active. Hardware sets this bit = 1 when the counter in the GPTIMER0CTRL register transitions to zero. Write -- 0: no effect. 1: clear this bit to 0. |
| reserved | 23:20 | ro | 0x0 | reserved |

| Field Name | Bits | Type | Reset Value | Description |
|----------------------------------|------|------|-------------|---|
| XUSBPS_IXR_UP_MASK (IXR_UP) | 19 | rw | 0x0 | Host Periodic raw interrupt status. (Host mode) Read -- 0: inactive. 1: active. Note: Hardware sets this bit = 1 when a periodic TD is completed with IOC = 1. Write -- 0: no effect. 1: clear the interrupt bit to 0. |
| XUSBPS_IXR_UA_MASK (IXR_UA) | 18 | rw | 0x0 | Host Async Schedule raw interrupt status. (Host mode) Read -- 0: inactive. 1: active. Note: Hardware sets this bit = 1 when an async TD is completed with IOC = 1. Write -- 0: no effect. 1: clear the interrupt bit to 0. |
| reserved | 17 | ro | 0x0 | RESERVED |
| XUSBPS_IXR_NAK_MASK (IXR_NAK) | 16 | ro | 0x0 | NAK Interrupt (Device mode), read-only. Read -- 0: inactive. 1: active. Note: Hardware sets this bit = 1 when the endpoint sends a NAK response and NAK bit is set. Write -- 0: no effect. 1: clear the interrupt bit to 0. |
| XUSBPS_IXR_AS_MASK (IXR_AS) | 15 | ro | 0x0 | Async Schedule Processing Status (EHCI) (Host mode), read-only. 0: inactive. 1: active, async schedule is enabled. Note: This status bit is used with the usb.USBCMD [ASE] enable bit. When the software sets usb.USBCMD [ASE], this bit reflects when HW really enabled processing async schedule. |
| XUSBPS_IXR_PS_MASK (IXR_PS) | 14 | ro | 0x0 | Periodic Schedule Processing Status (EHCI) (Host mode), read-only. 0: inactive. 1: active, periodic schedule is enabled. Note: This status bit is used with the usb.USBCMD [PSE] enable bit. When the software sets usb.USBCMD [PSE], this bit reflects when HW really enabled processing periodic schedule. |
| XUSBPS_IXR_RCL_MASK (IXR_RCL) | 13 | ro | 0x0 | Reclamation (EHCI) (Host mode), read-only. 0: unprocessed async transactions. 1: empty async schedule. |

| Field Name | Bits | Type | Reset Value | Description |
|------------------------------------|------|------|-------------|---|
| XUSBPS_IXR_HCH_MASK (IXR_HCH) | 12 | ro | 0x0 | HCHalted (EHCI) (Host mode). This bit is a zero whenever the Run/Stop bit is a one. The Controller sets this bit to one after it has stopped executing because of the Run/Stop bit being set to 0, either by software or by the Controller hardware (e.g. internal error). |
| reserved | 11 | ro | 0x0 | reserved |
| XUSBPS_IXR_ULPI_MASK (IXR_ULPI) | 10 | rw | 0x0 | ULPI Event Completion Interrupt (Host and Device mode). 0: not completed. 1: completed (write 1 to clear). |
| reserved | 9 | ro | 0x0 | reserved |
| XUSBPS_IXR_SLE_MASK (IXR_SLE) | 8 | rw | 0x0 | DCSuspend (Device mode). Write-to-clear. When the controller enters a suspend state from an active state, this bit will be set to a one. This bit is only cleared by software writing a 1 to it. |
| XUSBPS_IXR_SR_MASK (IXR_SR) | 7 | rw | 0x0 | SOF Received (Device and Host mode). Indicates start-of-frame detected. 0: not detected 1: SOF detected by hardware (write 1 to clear) Device mode -- When the controller detects an SOF on the ULPI bus, this bit is set. This normally occurs at 1 ms or 125 us intervals. Host mode -- The controller sets this bit every 125 us. Host software can use this tic for a time base. |
| XUSBPS_IXR_UR_MASK (IXR_UR) | 6 | rw | 0x0 | USB Reset Received (Device mode). Indicates a USB reset detected by hardware on ULPI bus. 0: not detected 1: reset detected by hardware (write 1 to clear) |
| XUSBPS_IXR_AA_MASK (IXR_AA) | 5 | rw | 0x0 | Async Schedule Advance (EHCI) (Host mode). The async advance interrupt can be generated when the controller advances the async schedule. 0: no change 1: controller advanced (write 1 to clear) This event is primed using the async advance doorbell bit, usb.USBCMD [6]. |
| SEI | 4 | rw | 0x0 | System Error (EHCI). AHB interconnect. 0: no error detected. 1: AHB error received (write 1 to clear) |

| Field Name | Bits | Type | Reset Value | Description |
|----------------------------------|------|------|-------------|---|
| XUSBPS_IXR_FRE_MASK (IXR_FRE) | 3 | rw | 0x0 | Frame List Rollover (EHCI?). Write-to-clear. Read: 0: no rollover. 1: roll over to frame element 0. Write: 0: no effect. 1: clear bit to 0. |
| XUSBPS_IXR_PC_MASK (IXR_PC) | 2 | rw | 0x0 | Port Change Detect. The Controller in host mode sets this bit to a one when on any port a Connect Status occurs, a Port Enable/Disable Change occurs, or the Force Port Resume bit is set as the result of a J-K transition on the suspended port. The Controller in device mode sets this bit to a one when it detects resume signaling or the port controller enters the full or high-speed operational state. When the port controller exits the full or high-speed operation states due to Reset or Suspend events, the notification mechanisms are the USB Reset Received bit and the DCSuspend bits respectively. |
| XUSBPS_IXR_UE_MASK (IXR_UE) | 1 | rw | 0x0 | USB Error Interrupt. When completion of a USB transaction results in an error condition, this bit is set by the Controller |
| XUSBPS_IXR_UI_MASK (IXR_UI) | 0 | rw | 0x0 | USB Packet Interrupt on Completion (IOC). Write-to-clear. This bit is set by the hardware in situations: * after a transaction descriptor (TD or dTD) is finished and it's interrupt on complete (IOC) bit set. * a short packet is detected. A short packet is when the actual number of bytes received was less than expected. |

Register ([usb](#)) XUSBPS_IER_OFFSET

| | |
|------------------|--------------------------------------|
| Name | XUSBPS_IER_OFFSET |
| Software Name | IER |
| Relative Address | 0x00000148 |
| Absolute Address | usb0: 0xE0002148 usb1: 0xE0003148 |
| Width | 26 bits |
| Access Type | mixed |
| Reset Value | 0x00000000 |
| Description | Interrupts and Enables |

Register XUSBPS_IER_OFFSET Details

The to software are enabled with this register. An interrupt is generated when a bit is set and the corresponding interrupt is active. The USB Status register (USBSTS) still shows interrupt sources even if they are disabled by the USBINTR register, allowing polling of interrupt events by the software.

| Field Name | Bits | Type | Reset Value | Description |
|---------------------------------|-------|------|-------------|--|
| XUSBPS_IXR_TI1_MASK (IXR_TI1) | 25 | rw | 0x0 | GP Timer 1 Interrupt Enable (Host/Device). 0: disable. 1: enable. Refer to raw interrupt status: USBSTS [TI1]. |
| XUSBPS_IXR_TI0_MASK (IXR_TI0) | 24 | rw | 0x0 | GP Timer 0 Interrupt Enable (Host/Device). 0: disable. 1: enable. Refer to raw interrupt status: USBSTS [TI0]. |
| reserved | 23:20 | ro | 0x0 | reserved |
| XUSBPS_IXR_UP_MASK (IXR_UP) | 19 | rw | 0x0 | Host Periodic Interrupt Enable (Host mode). 0: disable. 1: enable. Refer to raw interrupt status: USBSTS [UPI]. |
| XUSBPS_IXR_UA_MASK (IXR_UA) | 18 | rw | 0x0 | Host Async Interrupt Enable (Host mode). 0: disable. 1: enable. Refer to raw interrupt status: USBSTS [UAE]. |
| reserved | 17 | ro | 0x0 | reserved |
| XUSBPS_IXR_NAK_MASK (IXR_NAK) | 16 | ro | 0x0 | NAK Interrupt Enable (Device mode). 0: disable. 1: enable. Refer to raw interrupt status: USBSTS [NAKI]. |
| reserved | 11 | ro | 0x0 | reserved [15:11] |
| XUSBPS_IXR_ULPI_MASK (IXR_ULPI) | 10 | rw | 0x0 | ULPI Interrupt Enable (Host/Device). 0: disable. 1: enable. Refer to raw interrupt status: USBSTS [ULPII]. |
| reserved | 9 | ro | 0x0 | reserved |
| XUSBPS_IXR_SLE_MASK (IXR_SLE) | 8 | rw | 0x0 | DCSuspend Interrupt Enable (Device mode). 0: disable. 1: enable. Refer to raw interrupt status: USBSTS [SLI]. |
| XUSBPS_IXR_SR_MASK (IXR_SR) | 7 | rw | 0x0 | SOF Received Interrupt Enable (Device?). 0: disable. 1: enable. Refer to raw interrupt status: USBSTS [SRI]. |

| Field Name | Bits | Type | Reset Value | Description |
|-------------------------------|------|------|-------------|--|
| XUSBPS_IXR_UR_MASK (IXR_UR) | 6 | rw | 0x0 | USB Reset Received Interrupt Enable (Device mode). 0: disable. 1: enable interrupt on receiving USB reset. Refer to raw interrupt status: USBSTS [URI]. |
| XUSBPS_IXR_AA_MASK (IXR_AA) | 5 | rw | 0x0 | Async Advance Interrupt Enable (EHCI). 0: disable. 1: enable. Refer to raw interrupt status: USBSTS [AAI]. |
| SEE | 4 | rw | 0x0 | System Error Interrupt Enable (EHCI). 0: disable. 1: enable. Refer to raw interrupt status: USBSTS [SEI]. |
| XUSBPS_IXR_FRE_MASK (IXR_FRE) | 3 | rw | 0x0 | Frame List Rollover Interrupt Enable (EHCI). 0: disable. 1: enable. Refer to raw interrupt status: USBSTS [FRI]. |
| XUSBPS_IXR_PC_MASK (IXR_PC) | 2 | rw | 0x0 | Port Change Detect Interrupt Enable (EHCI). 0: disable. 1: enable. Refer to raw interrupt status: USBSTS [PCI]. |
| XUSBPS_IXR_UE_MASK (IXR_UE) | 1 | wtc | 0x0 | USB Error Interrupt Enable (EHCI). 0: disable. 1: enable. Refer to raw interrupt status: USBSTS [UEI]. |
| XUSBPS_IXR_UI_MASK (IXR_UI) | 0 | rw | 0x0 | USB Interrupt Enable (EHCI). 0: disable. 1: enable. Refer to raw interrupt status: USBSTS [UI]. |

Register ([usb](#)) XUSBPS_FRAME_OFFSET

| | |
|------------------|--------------------------------------|
| Name | XUSBPS_FRAME_OFFSET |
| Software Name | FRAME |
| Relative Address | 0x0000014C |
| Absolute Address | usb0: 0xE000214C usb1: 0xE000314C |
| Width | 14 bits |
| Access Type | rw |
| Reset Value | 0x00000000 |
| Description | Frame List Index |

Register XUSBPS_FRAME_OFFSET Details

This register is used by the host controller to index the periodic frame list. The register updates every 125 us (once each micro-frame).

| Field Name | Bits | Type | Reset Value | Description |
|------------|------|------|-------------|---|
| FRINDEX | 13:0 | rw | 0x0 | Frame Index (EHCI) (Host and Device mode). Host mode -- Read: current frame index value. Write: set the frame index value. Device mode -- Read-only: frame index from received packet. |

Register ([usb](#)) XUSBPS_LISTBASE_OFFSET

| | |
|------------------|--------------------------------------|
| Name | XUSBPS_LISTBASE_OFFSET |
| Software Name | LISTBASE |
| Relative Address | 0x00000154 |
| Absolute Address | usb0: 0xE0002154 usb1: 0xE0003154 |
| Width | 32 bits |
| Access Type | mixed |
| Reset Value | 0x00000000 |
| Description | Host/Device Address dual-use |

Register XUSBPS_LISTBASE_OFFSET Details

Host mode: PERIODICLISTBASE.

Device mode: Device Address Advance and

| Field Name | Bits | Type | Reset Value | Description |
|------------------|-------|------|-------------|--|
| PERBASE_USBADRA | 31:25 | rw | 0x0 | Host mode ---- Periodic List Base Address. Memory address bits [31:25]. Device Mode ---- Device Address Advance. When this bit is '0b', any writes to USBADR are instantaneous. When this bit is written to a '1' at the same time or before USBADR is written, the write to the USBADR field is staged and held in a hidden register. After an IN occurs on endpoint 0 and is ACKed, USBADR will be loaded from the hidden register. Hardware will automatically clear this bit on the following conditions: 1) IN is ACKed to endpoint 0. (USBADR is updated from hidden register). 2) OUT/SETUP occur to endpoint 0. (USBADR is not updated). 3) Device Reset occurs (USBADR is reset to 0). |
| PERBASE_USBADR | 24 | rw | 0x0 | Host mode ---- Periodic List Base Address. Memory address bits [24]. Device Mode ---- |
| PERBASE_Reserved | 23:12 | rw | 0x0 | Host mode ---- Periodic List Base Address. Memory address bits [23:12]. Device Mode ---- Reserved. |
| reserved | 11:0 | ro | 0x0 | reserved |

Register ([usb](#)) XUSBPS_ASYNC_LISTADDR_OFFSET

| | |
|------------------|--------------------------------------|
| Name | XUSBPS_ASYNC_LISTADDR_OFFSET |
| Software Name | ASYNC_LISTADDR |
| Relative Address | 0x00000158 |
| Absolute Address | usb0: 0xE0002158 usb1: 0xE0003158 |
| Width | 32 bits |
| Access Type | mixed |
| Reset Value | 0x00000000 |
| Description | Host/Device dual-use |

Register XUSBPS_ASYNC_LISTADDR_OFFSET Details

Host mode: ASYNC_LISTADDR.

Device mode: ENDPOINT_LISTADDR.

| Field Name | Bits | Type | Reset Value | Description |
|----------------|-------|------|-------------|--|
| ASYBASE_EPBASE | 31:11 | rw | 0x0 | Host mode -- Async List Base Address. Memory address bits [31:11] point to the Queue Heads (QH) . Refer to [ASYBASE] bit field for [10:5] address bits. Device Mode -- Endpoint List Base Address. Memory address bits [31:11] point to the Queue Heads (QH). There are unused memory locations. The stride for the base address is for a 16-endpoint model using both IN and OUT functions. However, twelve endpoints are implemented. |
| ASYBASE | 10:5 | rw | 0x0 | Host mode ---- Asynchronous List Base Address. Memory address bits [10:5]. Device Mode ---- Reserved. |
| reserved | 4:0 | ro | 0x0 | reserved |

Register ([usb](#)) XUSBPS_TTCTRL_OFFSET

| | |
|------------------|--------------------------------------|
| Name | XUSBPS_TTCTRL_OFFSET |
| Software Name | TTCTRL |
| Relative Address | 0x0000015C |
| Absolute Address | usb0: 0xE000215C usb1: 0xE000315C |
| Width | 32 bits |
| Access Type | mixed |
| Reset Value | 0x00000000 |
| Description | TT Control |

Register XUSBPS_TTCTRL_OFFSET Details

This register contains parameters needed for internal TT operations.

| Field Name | Bits | Type | Reset Value | Description |
|---------------------------------------|-------|------|-------------|--|
| reserved | 31 | ro | 0x0 | reserved |
| XUSBPS_TTCTRL_HUBA_DDR_MASK (HUBADDR) | 30:24 | rw | 0x0 | Internal TT Hub Address Representation. This field is used to match against the Hub Address field in QH & siTD to determine if the packet is routed to the internal TT for directly attached FS/LS devices. If the Hub Address in the QH or siTD does not match this address then the packet will be broadcast on the High Speed ports destined for a downstream High Speed hub with the address in the QH/siTD. |

| Field Name | Bits | Type | Reset Value | Description |
|------------|------|------|-------------|--|
| reserved | 23:2 | ro | 0x0 | reserved |
| TTAS | 1 | rw | 0x0 | Embedded TT Asynchronous Buffers Clear. This field will clear all pending transactions in the embedded TT Asynchronous Buffer(s). The clear will take as much time as necessary to clear buffer without interfering with a transaction in progress. TTAC will return to zero after being set by software only after the actual clear occurs. The TT supports up to two contexts. |
| TTAC | 0 | ro | 0x0 | Embedded TT Async Buffers Status. This read only bit will be '1' if one or more transactions are being held in the embedded TT Asynchronous Buffers. When this bit is a zero, then all outstanding transactions in the embedded TT have been flushed. |

Register ([usb](#)) XUSBPS_BURSTSIZE_OFFSET

| | |
|------------------|--------------------------------------|
| Name | XUSBPS_BURSTSIZE_OFFSET |
| Software Name | BURSTSIZE |
| Relative Address | 0x00000160 |
| Absolute Address | usb0: 0xE0002160 usb1: 0xE0003160 |
| Width | 17 bits |
| Access Type | rw |
| Reset Value | 0x00001010 |
| Description | Burst Size |

Register XUSBPS_BURSTSIZE_OFFSET Details

This register controls the burst size used during data movement on the initiator/master interface.

| Field Name | Bits | Type | Reset Value | Description |
|----------------------------------|------|------|-------------|---|
| XUSBPS_BURSTSIZE_TX_MASK (TX) | 16:8 | rw | 0x10 | <p>Programmable TX Burst Length. Default is the constant VUSB_HS_TX_BURST. This register represents the maximum length of a burst in 32-bit words while moving data from system memory to the USB bus.</p> <p>If field AHBBRST of register SBUSCFG is different from zero, this field TXPBURST will return the value of the INCRx length.</p> <p>Supported values are integer values from 4 to 128. It is recommended to set this value to a integer sub-multiple of VUSB_HS_TX_CHAN. Different values will not use all the available buffer space, preventing proper TX endpoint priming in stream disable mode (SDIS bit of USBMODE register set to '1').</p> |
| XUSBPS_BURSTSIZE_RX_MASK (RX) | 7:0 | rw | 0x10 | <p>Programmable RX Burst Length. Default is the constant VUSB_HS_RX_BURST. This register represents the maximum length of a burst in 32-bit words while moving data from the USB bus to system memory. If field AHBBRST of register SBUSCFG is different from zero, this field RXPBRUST will return the value of the INCRx length.</p> <p>The supported values are integer values from 4 to 128. It is recommended to set this value to a integer sub-multiple of VUSB_HS_RX_DEPTH.</p> |

Register ([usb](#)) XUSBPS_TXFILL_OFFSET

| | |
|------------------|--------------------------------------|
| Name | XUSBPS_TXFILL_OFFSET |
| Software Name | TXFILL |
| Relative Address | 0x00000164 |
| Absolute Address | usb0: 0xE0002164 usb1: 0xE0003164 |
| Width | 22 bits |
| Access Type | mixed |
| Reset Value | 0x00000000 |
| Description | TxFIFO Fill Tuning |

Register XUSBPS_TXFILL_OFFSET Details

The fields in this register control performance tuning associated with how the Controller posts data to the TX latency FIFO before moving the data onto the USB bus.

| Field Name | Bits | Type | Reset Value | Description |
|---|-------|------|-------------|---|
| XUSBPS_TXFILL_BURST_MASK (BURST) | 21:16 | rw | 0x0 | FIFO Burst Threshold: This register controls the number of data bursts that are posted to the TX latency FIFO in host mode before the packet begins on to the bus. The minimum value is 2 and this value should be as low as possible to maximize USB performance. A higher value can be used in systems with unpredictable latency and/or insufficient bandwidth, where the FIFO may under run because the data transferred from the latency FIFO to USB occurs before it can be replenished from system memory. This value is ignored if the Stream Disable bit in USBMODE register is set (SDIS). |
| reserved | 15:13 | ro | 0x0 | reserved |
| XUSBPS_TXFILL_HEALTH_MASK (HEALTH) | 12:8 | rw | 0x0 | Scheduler Health Counter. This register increments when the Controller fails to fill the TX latency FIFO to the level programmed by TXFIFOTHRES before running out of time to send the packet before the next Start-Of-Frame. This health counter measures the number of times this occurs to provide feedback to selecting a proper TXSCHOH. Writing to this register will clear the counter. This counter will max. at 31. |
| reserved | 7 | ro | 0x0 | RESERVED |
| XUSBPS_TXFILL_OVERHEAD_MASK (OVERHEAD) | 6:0 | rw | 0x0 | Scheduler Overhead. This register adds an additional fixed offset to the schedule time estimator described above as Tff. As an approximation, the value chosen for this register should limit the number of back-off events captured in the TXSCHHEALTH to less than 10 per second in a highly utilized bus. Choosing a value that is too high for this register is not desired as it can needlessly reduce USB utilization. The time unit represented in this register is 1.267us when a device is connected in High-Speed Mode for OTG(on the go) & SPH(single port host) implementations. The time unit represented in this register is 6.333us when a device is connected in Low/Full Speed Mode for OTG & SPH implementations. The time unit represented in this register is always 1.267us for the MPH implementation |

Register ([usb](#)) TXTTFILLTUNING

Name TXTTFILLTUNING
Relative Address 0x00000168

Absolute Address usb0: 0xE0002168
 usb1: 0xE0003168

Width 13 bits

Access Type mixed

Reset Value 0x00000000

Description TT TX latency FIFO

Register TXTTFILLTUNING Details

This register provides a function similar to TXFILLTUNING except there is no equivalent to TXFIFOTHRES because the TT TX latency FIFO is always loaded in a single burst. Even

| Field Name | Bits | Type | Reset Value | Description |
|---------------|------|------|-------------|---|
| TXTTSCHHEALTH | 12:8 | rw | 0x0 | TT Scheduler Health Counter Same description as TXSCHHEALTH |
| reserved | 7:5 | ro | 0x0 | reserved |
| TXTTSCHOH | 4:0 | rw | 0x0 | TT Scheduler Overhead Same description as TXSCHOH. The time unit represented in this register is 6.333us. |

Register ([usb](#)) IC_USB

Name IC_USB

Relative Address 0x0000016C

Absolute Address usb0: 0xE000216C
 usb1: 0xE000316C

Width 32 bits

Access Type mixed

Reset Value 0x00000000

Description Low and Fast Speed Control constants

Register IC_USB Details

This register enable and controls the IC_USB FS/LS transceiver.

| Field Name | Bits | Type | Reset Value | Description |
|------------|-------|------|-------------|---|
| IC8 | 31 | ro | 0x0 | Inter-Chip transceiver enable 8. These bits enables the Inter-Chip transceiver for each port (for the MPH case). To enable the interface, the bits PTS must be set to '011b' in the PORTSC8. Writing a '1' to each bit selects the IC_USB interface for that port. |
| IC_VDD8 | 30:28 | ro | 0x0 | Inter-Chip voltage selection 8 It selects which voltage is being supplied to the peripheral through each port This field is read-only and set to '000b' in case of device mode operation. This field is read-only and set to '000b' in case of Single port host controller. |
| IC7 | 27 | ro | 0x0 | Inter-Chip transceiver enable 7. These bits enables the Inter-Chip transceiver for each port (for the MPH case). To enable the interface, the bits PTS must be set to '011b' in the PORTSC7. Writing a '1' to each bit selects the IC_USB interface for that port. |
| IC_VDD7 | 26:24 | ro | 0x0 | Inter-Chip voltage selection 7 It selects which voltage is being supplied to the peripheral through each port This field is read-only and set to '000b' in case of device mode operation. This field is read-only and set to '000b' in case of Single port host controller. |
| IC6 | 23 | ro | 0x0 | Inter-Chip transceiver enable 6. These bits enables the Inter-Chip transceiver for each port (for the MPH case). To enable the interface, the bits PTS must be set to '011b' in the PORTSC6. Writing a '1' to each bit selects the IC_USB interface for that port. |
| IC_VDD6 | 22:20 | ro | 0x0 | Inter-Chip voltage selection 6 It selects which voltage is being supplied to the peripheral through each port This field is read-only and set to '000b' in case of device mode operation. This field is read-only and set to '000b' in case of Single port host controller. |
| IC5 | 19 | ro | 0x0 | Inter-Chip transceiver enable 5. These bits enables the Inter-Chip transceiver for each port (for the MPH case). To enable the interface, the bits PTS must be set to '011b' in the PORTSC5. Writing a '1' to each bit selects the IC_USB interface for that port. |

| Field Name | Bits | Type | Reset Value | Description |
|------------|-------|------|-------------|--|
| IC_VDD5 | 18:16 | ro | 0x0 | Inter-Chip voltage selection 5 It selects which voltage is being supplied to the peripheral through each port This field is read-only and set to '000b' in case of device mode operation. This field is read-only and set to '000b' in case of Single port host controller. |
| IC4 | 15 | ro | 0x0 | Inter-Chip transceiver enable 4. These bits enables the Inter-Chip transceiver for each port (for the MPH case). To enable the interface, the bits PTS must be set to '011b' in the PORTSC4. Writing a '1' to each bit selects the IC_USB interface for that port. |
| IC_VDD4 | 14:12 | ro | 0x0 | Inter-Chip voltage selection 4 It selects which voltage is being supplied to the peripheral through each port This field is read-only and set to '000b' in case of device mode operation. This field is read-only and set to '000b' in case of Single port host controller. |
| IC3 | 11 | ro | 0x0 | Inter-Chip transceiver enable 3. These bits enables the Inter-Chip transceiver for each port (for the MPH case). To enable the interface, the bits PTS must be set to '011b' in the PORTSC3. Writing a '1' to each bit selects the IC_USB interface for that port. |
| IC_VDD3 | 10:8 | ro | 0x0 | Inter-Chip voltage selection 3 It selects which voltage is being supplied to the peripheral through each port. This field is read-only and set to '000b' in case of device mode operation. This field is read-only and set to '000b' in case of Single port host controller. |
| IC2 | 7 | ro | 0x0 | Inter-Chip transceiver enable 2. These bits enables the Inter-Chip transceiver for each port (for the MPH case). To enable the interface, the bits PTS must be set to '011b' in the PORTSC2. Writing a '1' to each bit selects the IC_USB interface for that port. |
| IC_VDD2 | 6:4 | ro | 0x0 | Inter-Chip voltage selection 2 It selects which voltage is being supplied to the peripheral through each port. This field is read-only and set to '000b' in case of device mode operation. This field is read-only and set to '000b' in case of Single port host controller. |

| Field Name | Bits | Type | Reset Value | Description |
|------------|------|------|-------------|---|
| IC1 | 3 | rw | 0x0 | Inter-Chip transceiver enable 1. These bits enables the Inter-Chip transceiver for each port (for the MPH case). To enable the interface, the bits PTS must be set to '011b' in the PORTSC1. Writing a '1' to each bit selects the IC_USB interface for that port. If the Controller is not a MPH implementation, IC8 to IC2 will be '0' and Read-Only. |
| IC_VDD1 | 2:0 | rw | 0x0 | Inter-Chip voltage selection 1 -- Host mode. Select the voltage being supplied to the peripheral: 000: No voltage 001: 1.0V 010: 1.2V 011: 1.5V 100: 1.8V 101: 3.0V 110, 111: reserved The voltage negotiation should happen between enabling port power (PP) in PORTSC1 register and asserting the run/stop bit in USBCMD register. Device Mode: Read-only and equals 000. |

Register ([usb](#)) XUSBPS_ULPIVIEW_OFFSET

| | |
|------------------|--------------------------------------|
| Name | XUSBPS_ULPIVIEW_OFFSET |
| Software Name | ULPIVIEW |
| Relative Address | 0x00000170 |
| Absolute Address | usb0: 0xE0002170 usb1: 0xE0003170 |
| Width | 32 bits |
| Access Type | mixed |
| Reset Value | 0x08000000 |
| Description | ULPI Viewport |

Register XUSBPS_ULPIVIEW_OFFSET Details

The register provides indirect access to the ULPI PHY register set. Although the core performs access to the

ULPI PHY register set, there may be extraordinary circumstances where software may need direct access.

| Field Name | Bits | Type | Reset Value | Description |
|---------------------------------------|-------|------|-------------|--|
| XUSBPS_ULPIVIEW_WU_MASK (WU) | 31 | rw | 0x0 | ULPI Wake Up Operation. Write: 0: no affect. 1: execute the Wake Up operation (no undoing). Read: 0: operation complete. 1: operation in-progress. Note: Do not issue a ULPI Wake Up and ULPI Read/Write (via Viewport operation) with the same register write. |
| XUSBPS_ULPIVIEW_RUN_MASK (RUN) | 30 | rw | 0x0 | ULPI Viewport Transaction. Write: 0: no affect. 1: execute the ULPI viewport transaction (no undoing). Read: 0: transaction complete. 1: transaction in-progress. Note: Do not issue a ULPI Wake Up and Viewport operations with the same register write. |
| XUSBPS_ULPIVIEW_RW_MASK (RW) | 29 | rw | 0x0 | ULPI Viewport Read/Write Select. 0: read operation. 1: write operation. |
| reserved | 28 | ro | 0x0 | reserved |
| XUSBPS_ULPIVIEW_SS_MASK (SS) | 27 | ro | 0x1 | ULPI Synchronous State 0: In another state (i.e. carkit, serial, low power). 1: Normal synchronous state. This bit represents the state of the ULPI interface. Before reading this bit, the ULPIPORT field should be set accordingly if used in a MPH implementation. |
| ULPIPORT | 26:24 | rw | 0x0 | Reserved, always write 0. |
| XUSBPS_ULPIVIEW_ADDR_MASK (ADDR) | 23:16 | rw | 0x0 | ULPI Data Address. When a read or write operation is commanded, the address of the operation is written to this field. |
| XUSBPS_ULPIVIEW_DATRD_MASK (DATRD) | 15:8 | ro | 0x0 | ULPI Data Read. After a read operation completes, the result is placed in this field. |
| XUSBPS_ULPIVIEW_DATWR_MASK (DATWR) | 7:0 | rw | 0x0 | ULPI Data Write. When a write operation is commanded, the data to be sent is written to this field |

Register ([usb](#)) XUSBPS_EPNAKISR_OFFSET

Name XUSBPS_EPNAKISR_OFFSET

Software Name EPNAKISR
 Relative Address 0x00000178
 Absolute Address usb0: 0xE0002178
 usb1: 0xE0003178
 Width 32 bits
 Access Type wtc
 Reset Value 0x00000000
 Description Endpoint NAK (Device mode)

Register XUSBPS_EPNAKISR_OFFSET Details

| Field Name | Bits | Type | Reset Value | Description |
|------------|-------|------|-------------|---|
| EPTN | 31:16 | wtc | 0x0 | TX Endpoint NAK (Device mode). The Endpoint bit is set = 1 when the device controller sends a NAK handshake on a received IN token for the corresponding endpoint. Bit[16]: Endpoint 0. Bit[17]: Endpoint 1. ... Bit[28]: Endpoint 12. Bits[31:29]: reserved. |
| EPRN | 15:0 | wtc | 0x0 | RX Endpoint NAK (Device mode). The bit is set = 1 when the Controller sends a NAK handshake on a received OUT or PING token for the corresponding endpoint. Bit[0]: Endpoint 0. Bit[1]: Endpoint 1. ... Bit[12]: Endpoint 12. Bits[15:13]: reserved. |

Register ([usb](#)) XUSBPS_EPNAKIER_OFFSET

Name XUSBPS_EPNAKIER_OFFSET
 Software Name EPNAKIER
 Relative Address 0x0000017C
 Absolute Address usb0: 0xE000217C
 usb1: 0xE000317C
 Width 32 bits
 Access Type rw
 Reset Value 0x00000000
 Description Endpoint NAK (Device mode)

Register XUSBPS_EPNAKIER_OFFSET Details

| Field Name | Bits | Type | Reset Value | Description |
|------------|-------|------|-------------|---|
| EPTNE | 31:16 | rw | 0x0 | TX Endpoint NAK Enable (Device mode). 0: disable. 1: enable. Each bit is an enable bit for the corresponding TX Endpoint NAK. If NAK is enabled and the corresponding TX Endpoint NAK bit is set, then the NAK Interrupt bit is set. Bit[16]: Endpoint 0. Bit[17]: Endpoint 1. ... Bit[28]: Endpoint 12. Bits[31:29]: reserved. |
| EPRNE | 15:0 | rw | 0x0 | RX Endpoint NAK Enable (Device mode). 0: disable. 1: enable. Each bit is an enable bit for the corresponding RX Endpoint NAK. If NAK is enabled and the corresponding RX Endpoint NAK bit is set, then the NAK Interrupt bit is set. Bit[0]: Endpoint 0. Bit[1]: Endpoint 1. ... Bit[12]: Endpoint 12. Bits[15:13]: reserved. |

Register ([usb](#)) CONFIGFLAG

| | |
|------------------|--------------------------------------|
| Name | CONFIGFLAG |
| Relative Address | 0x00000180 |
| Absolute Address | usb0: 0xE0002180 usb1: 0xE0003180 |
| Width | 32 bits |
| Access Type | ro |
| Reset Value | 0x00000001 |
| Description | reserved |

Register CONFIGFLAG Details

| Field Name | Bits | Type | Reset Value | Description |
|------------|------|------|-------------|-------------|
| reserved | 31:0 | ro | 0x1 | reserved |

Register ([usb](#)) XUSBPS_PORTSCR1_OFFSET

| | |
|------------------|--------------------------------------|
| Name | XUSBPS_PORTSCR1_OFFSET |
| Software Name | PORTSCR1 |
| Relative Address | 0x00000184 |
| Absolute Address | usb0: 0xE0002184 usb1: 0xE0003184 |
| Width | 32 bits |
| Access Type | mixed |
| Reset Value | 0x8C000004 |
| Description | Port Status & Control |

Register XUSBPS_PORTSCR1_OFFSET Details

The Controller implement one The number of port registers implemented by a particular instantiation is documented in the HCSPARAM register. Software uses this information as an input parameter to determine how many ports need service. This implement contains only 1 host port.

| Field Name | Bits | Type | Reset Value | Description |
|--|-------|------|-------------|--|
| PTS | 31:30 | rw | 0x2 | PHY Type Status constant (Host/Device). [PTS2] + [PTS] bit fields: 010: ULPI interface. |
| STS | 29 | ro | 0x0 | Serial Transceiver Select constant (Host/Device). VUSB_HS_PHY_SERIAL = 0. Serial interface engine (SIE) not implemented. |
| PTW | 28 | ro | 0x0 | Parallel Transceiver Width constant (Host/Device). 0: 8-bit (60MHz) UTMI+ interface to ULPI. |
| XUSBPS_PORTSCR_PSP D_MASK (PORTSCR_PSPD) | 27:26 | rw | 0x3 | Port Speed operating mode (Host/Device). 00: Full Speed 01: Low Speed 10: High Speed 11: Not connected (default) |
| PTS2 | 25 | rw | 0x0 | Parallel Transceiver Select MSB (Host/Device). Refer to the [PTS] bit field for a description. |
| XUSBPS_PORTSCR_PFS C_MASK (PORTSCR_PFSC) | 24 | rw | 0x0 | Port Force Full Speed Connect -- Debug. 0: ??? (default) 1: write a 1 to force the port to only connect at Full Speed. Writing a 1 disables the chirp sequence that allows the port to identify itself as High Speed. This is useful for testing FS configurations with a HS host, hub or device. |

| Field Name | Bits | Type | Reset Value | Description |
|--|-------|------|-------------|--|
| XUSBPS_PORTSCR_PHC D_MASK (PORTSCR_PHCD) | 23 | ro | 0x0 | PHY Low Power Clock Disable - RW. Default = 0b. Writing this bit to a '1b' will disable the PHY clock. Writing a '0b' enables it. Reading this bit will indicate the status of the PHY clock. NOTE: The PHY clock cannot be disabled if it is being used as the system clock. In device mode, the PHY can be put into Low Power Clock Disable when the device is not running (USBCMD RS=0b) or the host has signaled suspend (PORTSCx SUSP=1b). Low Power Clock Disable will be cleared automatically when the host has signaled resume. Before forcing a resume from the device, the Controller driver must clear this bit. In host mode, the PHY can be put into Low Power Suspend Clock Disable when the downstream device has been put into suspend mode or when no downstream device is connected. Low Power Clock Disable is completely under the control of software. |
| XUSBPS_PORTSCR_WK OC_MASK (PORTSCR_WKOC) | 22 | ro | 0x0 | Wake on Over-current Enable Writing '1' to this bit enables the port to be sensitive to over-current conditions as wakeup events. This field is zero if Port Power (PP) is '0' or in device mode. This bit is output from the controller as signal pwrctl_wake_ovrcurr_en for use by an external power control circuit. Only used in host mode. |
| XUSBPS_PORTSCR_WK DS_MASK (PORTSCR_WKDS) | 21 | rw | 0x0 | Wake on Disconnect Enable (Host mode). 0: disable 1: enable In device mode, always set = 0. |
| XUSBPS_PORTSCR_WK CN_MASK (PORTSCR_WKCN) | 20 | rw | 0x0 | Wake on Connect Enable (Host mode). 0: disable 1: enable In device mode, always set = 0. |
| XUSBPS_PORTSCR_PTC _MASK (PORTSCR_PTC) | 19:16 | rw | 0x0 | Port Test Control. 0000: Normal operation. All others are test modes: 0001: J_STATE 0010: K_STATE 0011: SE0 (host) / NAK (device) 0100: Packet 0101: FORCE_ENABLE_HS 0110: FORCE_ENABLE_FS 0111: FORCE_ENABLE_LS Others: reserved |

| Field Name | Bits | Type | Reset Value | Description |
|--|-------|------|-------------|---|
| XUSBPS_PORTSCR_PIC_MASK (PORTSCR_PIC) | 15:14 | rw | 0x0 | Port Indicator Control outputs (EHCI) (Host mode). 00: Port indicators are off. 01: Amber (PL output signal EMIOUSBxPORTINDCTL0 is driven High). 10: Green (PL output signal EMIOUSBxPORTINDCTL1 is driven High). 11: undefined. Refer to the USB Specification Revision 2.0 for a description on how these bits are to be used. |
| XUSBPS_PORTSCR_PO_MASK (PORTSCR_PO) | 13 | ro | 0x0 | Port Owner hand off is not implemented. Hardwired to 0. |
| XUSBPS_PORTSCR_PP_MASK (PORTSCR_PP) | 12 | rw | 0x0 | Port Power enable (ECHI) (Host mode). Controls the PL output signal EMIOUSBxVBUSPWSELECT. 0: disable, driven Low. 1: enable, driven High. This bit represents the current setting of the switch ('0'=off, '1'=on). When power is not available on a port (i.e. [PP] equals to '0'), the port is non-functional and will not report attaches, detaches, etc. When an over-current condition is detected on a powered port and [PPC] is a one, the [PP] bit in each affected port may be transitioned by the controller driver from '1' to '0'(removing power from the port). |
| XUSBPS_PORTSCR_LS_MASK (PORTSCR_LS) | 11:10 | ro | 0x0 | Line State: 00: SE0 01: J-state 10: K-state 11: undefined. |
| XUSBPS_PORTSCR_HSP_MASK (PORTSCR_HSP) | 9 | ro | 0x0 | High-Speed Port status (Host and Device mode). 0: LS or FS mode 1: HS mode Note: [HSP] is redundant with [PSPD]. |
| XUSBPS_PORTSCR_PR_MASK (PORTSCR_PR) | 8 | rw | 0x0 | Port Reset - RW. Default = 0b. This field is zero if Port Power(PP) is '0'. Host mode: 1=Port is in Reset. 0=Port is not in Reset. Device Mode: This bit is a read only status bit. Device reset from the USB bus is also indicated in the USBSTS register |

| Field Name | Bits | Type | Reset Value | Description |
|--|------|------|-------------|--|
| XUSBPS_PORTSCR_SUSP_MASK (PORTSCR_SUSP) | 7 | rw | 0x0 | Suspend Host mode: 1=Port in suspend state. 0=Port not in suspend state. Port Enabled bit and Suspend bit of this register define the port states as follows: Bits [Port Enabled, Suspend] Port State 0x Disable 10 Enable 11 Suspend Device mode: Read Only. 1=Port in suspend state. 0=Port not in suspend state. In device mode this bit is a read only status bit. |
| XUSBPS_PORTSCR_FPR_MASK (PORTSCR_FPR) | 6 | rw | 0x0 | Force Port Resume 1= Resume detected/driven on port. 0=No resume (K-state) detected/driven on port. |
| XUSBPS_PORTSCR_OCC_MASK (PORTSCR_OCC) | 5 | rw | 0x0 | Over-current Change This bit gets set to '1' when there is a change to Over-current Active. Software clears this bit by writing a '1' to this bit position. When in host mode implementations the user can provide over-current detection to the vbus_pwr_fault input for this condition. For device mode this bit shall always be '0'. |
| XUSBPS_PORTSCR_OCA_MASK (PORTSCR_OCA) | 4 | ro | 0x0 | Over-current Active Value Meaning '1b' -> This port currently has an over-current condition. '0b' -> This port does not have an over-current condition. This bit will automatically transition from '1' to '0' when the over current condition is removed. For host mode implementations the user can provide over-current detection to the vbus_pwr_fault input for this condition. For device mode implementations this bit shall always be '0'. |
| XUSBPS_PORTSCR_PEC_MASK (PORTSCR_PEC) | 3 | wtc | 0x0 | Port Enabled Change If set to '1' indicates a Port Enabled/Disabled status change. Host mode: For the root hub, this bit gets set to a '1' only when a port is disabled due to disconnect on the port or due to the appropriate conditions existing at the EOF2 point (See Chapter 11 of the USB Specification). Software clears this by writing a '1' to it. This field is '0' if Port Power(PP) is '0'. Device mode: The device port is always enabled. (This bit will be '0'). |

| Field Name | Bits | Type | Reset Value | Description |
|--|------|------|-------------|--|
| XUSBPS_PORTSCR_PE_MASK (PORTSCR_PE) | 2 | wtc | 0x1 | Port Enabled 1 -> Enable 0-> Disable Host mode: Ports can only be enabled by Controller as a part of the reset and enable. Software cannot enable a port by writing a '1' to this field. Ports can be disabled by either a fault condition (disconnect event or other fault condition) or by the software. This field is '0' if Port Power(PP) is '0' in host mode. Device mode: The device port is always enabled. (This bit will be always '1'). |
| XUSBPS_PORTSCR_CSC_MASK (PORTSCR_CSC) | 1 | wtc | 0x0 | Connect Status Change If set to '1' indicates a change in Current Connect Status (CCS). Host mode: Indicates a change has occurred in the port's Current Connect Status. The Controller sets this bit for all changes to the port device connect status, even if system software has not cleared an existing connect status change. For example, the insertion status changes twice before system software has cleared the changed condition, hub hardware will be 'setting' an already-set bit (i.e., the bit will remain set). Software clears this bit by writing a '1' to it. This field is '0' if Port Power(PP) is '0' in host mode. Device mode: This bit is undefined in device mode. |
| XUSBPS_PORTSCR_CCS_MASK (PORTSCR_CCS) | 0 | ro | 0x0 | Current Connect Status. Host mode: 1 -> Device is present on port. 0 -> No device is present. Device mode: 1 -> Attached. 0 -> Not Attached. |

Register ([usb](#)) XUSBPS_OTGCSR_OFFSET

| | |
|------------------|--------------------------------------|
| Name | XUSBPS_OTGCSR_OFFSET |
| Software Name | OTGCSR |
| Relative Address | 0x000001A4 |
| Absolute Address | usb0: 0xE00021A4 usb1: 0xE00031A4 |
| Width | 32 bits |

Access Type mixed
 Reset Value 0x00001020
 Description OTG Status and Control

Register XUSBPS_OTGCSR_OFFSET Details

The OTGSC register has four sections:

- * OTG Interrupt enables (Read/Write)
- * OTG Interrupt status (Read/Write to Clear)
- * OTG Status inputs (Read Only)
- * OTG Controls (Read/Write)

IP Config Note: The Controller implements one On-The-Go (OTG) Status and Control register.

| Field Name | Bits | Type | Reset Value | Description |
|--|------|------|-------------|--|
| reserved | 31 | ro | 0x0 | reserved |
| XUSBPS_OTGSC_DPIE_MASK (OTGSC_DPIE) | 30 | rw | 0x0 | Data Pulse Interrupt Enable. 0: disable. 1: enable usb.OTGSC [DPIS] interrupt. |
| XUSBPS_OTGSC_1MSE_MASK (OTGSC_1MSE) | 29 | rw | 0x0 | 1 ms Timer Interrupt Enable. 0: disable. 1: enable usb.OTGSC [1msS] interrupt. |
| XUSBPS_OTGSC_BSEE_MASK (OTGSC_BSEE) | 28 | rw | 0x0 | B Session End Interrupt Enable. 0: disable. 1: enable usb.OTGSC [BSEIS] interrupt. |
| XUSBPS_OTGSC_BSVIE_MASK (OTGSC_BSVIE) | 27 | rw | 0x0 | B Session Valid Interrupt Enable. 0: disable. 1: enable usb.OTGSC [BSVIS] interrupt. |
| XUSBPS_OTGSC_ASVIE_MASK (OTGSC_ASVIE) | 26 | rw | 0x0 | A Session Valid Interrupt Enable. 0: disable. 1: enable usb.OTGSC [ASVIS] interrupt. |
| XUSBPS_OTGSC_AVVIE_MASK (OTGSC_AVVIE) | 25 | rw | 0x0 | Interrupt Enable. 0: disable. 1: enable usb.OTGSC [AVVIS] interrupt. |
| XUSBPS_OTGSC_IDIE_MASK (OTGSC_IDIE) | 24 | rw | 0x0 | USB ID Interrupt Enable. 0: disable. 1: enable usb.OTGSC [IDIS] interrupt. |
| reserved | 23 | ro | 0x0 | reserved |

| Field Name | Bits | Type | Reset Value | Description |
|--|------|------|-------------|---|
| XUSBPS_OTGSC_DPIS_MASK (OTGSC_DPIS) | 22 | wtc | 0x0 | Data Pulse Interrupt Status. 0: no pulses detected. 1: pulses detected. Write 1 to clear bit. The pulses being detected can be on DP or DM. Data bus pulsing is only detected when usb.USBMODE [CM] = 11 (Host mode) and usb.PORTSC0 [PP] = 0 (off). Non-latched status can be read using the [DPS] bit. |
| XUSBPS_OTGSC_1MSS_MASK (OTGSC_1MSS) | 21 | wtc | 0x0 | 1 millisecond Timer Interrupt Status. 0: no timer alert. 1: timer alert. Write 1 to clear bit. The hardware sets this bit every 1 milliseconds (based on a timer using 60 MHz ULPI). |
| XUSBPS_OTGSC_BSEIS_MASK (OTGSC_BSEIS) | 20 | wtc | 0x0 | B Session End Interrupt Status. 0: no event detected. 1: event detected. Write 1 to clear bit. This bit is set when VBus has fallen below the B session end threshold. |
| XUSBPS_OTGSC_BSVIS_MASK (OTGSC_BSVIS) | 19 | wtc | 0x0 | B Session Valid Interrupt Status. 0: no event detected. 1: event detected. Write 1 to clear bit. This bit is set when VBus has either risen above or fallen below the B session valid threshold (0.8 VDC). |
| XUSBPS_OTGSC_ASVIS_MASK (OTGSC_ASVIS) | 18 | wtc | 0x0 | A Session Valid Interrupt Status. 0: no event detected. 1: event detected. Write 1 to clear bit. This bit is set when VBus has either risen above or fallen below the B session valid threshold (0.8 VDC). |
| XUSBPS_OTGSC_AVVIS_MASK (OTGSC_AVVIS) | 17 | wtc | 0x0 | A Session End Interrupt Status. 0: no event detected. 1: event detected. Write 1 to clear bit. This bit is set when VBus has either risen above or fallen below the VBus valid threshold (4.4 VDC) on an A device. |
| XUSBPS_OTGSC_IDIS_MASK (OTGSC_IDIS) | 16 | wtc | 0x0 | USB ID Interrupt Status. 0: no interrupt latched 1: interrupt detected. Write 1 to clear this bit. This bit is set when a change on the ID input has been detected. |
| reserved | 15 | ro | 0x0 | reserved |
| XUSBPS_OTGSC_DPS_MASK (OTGSC_DPS) | 14 | ro | 0x0 | Data Bus Pulsing Status, read-only. 0: no pulses being detected. 1: pulses are being detected. Note: refer to the [DPSI] bit for more information. |

| Field Name | Bits | Type | Reset Value | Description |
|--|------|------|-------------|--|
| XUSBPS_OTGSC_1MST_MASK (OTGSC_1MST) | 13 | ro | 0x0 | 1 ms Timer High-Low Toggle, read-only. Software will usually read a 0. This bit toggles high-low every millisecond to set the [1msS] bit. |
| XUSBPS_OTGSC_BSE_MASK (OTGSC_BSE) | 12 | ro | 0x1 | B Session End Status, read-only. 0: Vbus not below threshold. 1: Vbus below threshold. |
| XUSBPS_OTGSC_BSV_MASK (OTGSC_BSV) | 11 | ro | 0x0 | B Session Valid Indicates VBus is above the B session valid threshold. |
| XUSBPS_OTGSC_ASV_MASK (OTGSC_ASV) | 10 | ro | 0x0 | A Session Valid Indicates VBus is above the A session valid threshold. |
| XUSBPS_OTGSC_AVV_MASK (OTGSC_AVV) | 9 | ro | 0x0 | A VBus Valid. Indicates VBus is above the A VBus valid threshold. |
| XUSBPS_OTGSC_ID_MASK (OTGSC_ID) | 8 | ro | 0x0 | USB ID'0' = A device, '1' = B device. |
| XUSBPS_OTGSC_HABA_MASK (OTGSC_HABA) | 7 | rw | 0x0 | Hardware assisted B-Disconnect to A-connect. 0: disabled. 1: enable automatic B-Disconnect to A-Connect sequence. |
| XUSBPS_OTGSC_HADP_MASK (OTGSC_HADP) | 6 | rw | 0x0 | Hardware assisted Data-Pulse 0: disable 1: hardware assisted data pulsing sequence starts. |
| XUSBPS_OTGSC_IDPU_MASK (OTGSC_IDPU) | 5 | rw | 0x1 | ID Pullup. Control the ID Pullup resistor. 0: off (the ID input will not be sampled). 1: on. |
| XUSBPS_OTGSC_DP_MASK (OTGSC_DP) | 4 | rw | 0x0 | Data Pulsing enable. 0: 1: pullup on DP is asserted for data pulsing during SRP. |
| XUSBPS_OTGSC_OT_MASK (OTGSC_OT) | 3 | rw | 0x0 | OTG Termination 0: 1: This bit must be set when the Controller is in device mode. It controls the pulldown on DM. |
| XUSBPS_OTGSC_HAAR_MASK (OTGSC_HAAR) | 2 | rw | 0x0 | Hardware Assist Auto-Reset'0' = Disabled, '1' = Enable automatic reset after connect on host port. |
| XUSBPS_OTGSC_VC_MASK (OTGSC_VC) | 1 | rw | 0x0 | VBUS Charge Setting this bit causes the VBus line to be charged. This is used for VBus pulsing during SRP. |
| XUSBPS_OTGSC_VD_MASK (OTGSC_VD) | 0 | rw | 0x0 | VBUS Discharge. Setting this bit causes VBus to discharge through a resistor. |

Register ([usb](#)) XUSBPS_MODE_OFFSET

| | |
|------------------|--------------------------------------|
| Name | XUSBPS_MODE_OFFSET |
| Software Name | MODE |
| Relative Address | 0x000001A8 |
| Absolute Address | usb0: 0xE00021A8 usb1: 0xE00031A8 |
| Width | 32 bits |
| Access Type | mixed |
| Reset Value | 0x00000000 |
| Description | USB Mode Selection |

Register XUSBPS_MODE_OFFSET Details

| Field Name | Bits | Type | Reset Value | Description |
|------------------------------|------|------|-------------|---|
| SRT | 15 | rw | 0x0 | Reseverd, set = 0. (Shorten Reset Time) |
| reserved | 14:6 | ro | 0x0 | reserved |
| VBPS | 5 | rw | 0x0 | Vbus Power Select'0' -> Output is '0''1' -> Output is '1' This bit is connected to the vbus_pwr_select output and can be used for any generic control but is named to be used by logic that selects between an on-chip Vbus power source (charge pump) and an off-chip source in systems when both are available. Only used in host mode. |
| XUSBPS_MODE_SDIS_MASK (SDIS) | 4 | rw | 0x0 | Stream Disable Mode'0' -> Inactive'1' -> Active Device mode: Setting to a '1' disables double priming on both RX and TX for low bandwidth systems. Host Mode: Setting to a '1' ensures that overruns/under runs of the latency FIFO are eliminated for low bandwidth systems where the RX and TX buffers are sufficient to contain the entire packet. |
| XUSBPS_MODE_SLOM_MASK (SLOM) | 3 | rw | 0x0 | Setup Lockout Mode This bit controls behavior of the setup lock mechanism.'0' -> Setup Lockouts On.'1' -> Setup Lockouts Off (DCD requires use of Setup Data Buffer Tripwire in USBCMD). Only used in device mode |

| Field Name | Bits | Type | Reset Value | Description |
|--------------------------|------|------|-------------|---|
| XUSBPS_MODE_ES_MASK (ES) | 2 | ro | 0x0 | Reserved, set = 0. (Endian Select) |
| XUSBPS_MODE_CM_MASK (CM) | 1:0 | rw | 0x0 | Controller Mode is defaulted to the proper mode for host only and device only implementations. For those designs that contain both host & device capability (OTG), the Controller will default to an idle state and will need to be initialized to the desired operating mode after reset. For combination host/device controllers, this register can only be written once after reset. If it is necessary to switch modes, software must reset the controller by writing to the RST bit in the USBCMD register before reprogramming this register. '00b' -> Idle (Default for combination host/device). '01b' -> Reserved. '10b' -> Controller in device mode (Default for device only controller). '11b' -> Controller in host mode (Default for host only controller). |

Register ([usb](#)) XUSBPS_EPSTAT_OFFSET

| | |
|------------------|--------------------------------------|
| Name | XUSBPS_EPSTAT_OFFSET |
| Software Name | EPSTAT |
| Relative Address | 0x000001AC |
| Absolute Address | usb0: 0xE00021AC usb1: 0xE00031AC |
| Width | 16 bits |
| Access Type | wtc |
| Reset Value | 0x00000000 |
| Description | Endpoint Status Setup (Device mode) |

Register XUSBPS_EPSTAT_OFFSET Details

| Field Name | Bits | Type | Reset Value | Description |
|----------------|------|------|-------------|---|
| ENDPTSETUPSTAT | 15:0 | wtc | 0x0 | Setup Endpoint Status (Device mode). When a Setup transaction is received, the corresponding bit is set = 1. Software reads the setup data from the Queue Head and then writes a 1 to clear the status bit. Bit[0]: Endpoint 0. Bit[1]: Endpoint 1. ... Bit[12]: Endpoint 12. Other bits: reserved. |

Register ([usb](#)) XUSBPS_EPPRIME_OFFSET

| | |
|------------------|--------------------------------------|
| Name | XUSBPS_EPPRIME_OFFSET |
| Software Name | EPPRIME |
| Relative Address | 0x000001B0 |
| Absolute Address | usb0: 0xE00021B0 usb1: 0xE00031B0 |
| Width | 32 bits |
| Access Type | wtc |
| Reset Value | 0x00000000 |
| Description | Endpoint Primer (Device mode) |

Register XUSBPS_EPPRIME_OFFSET Details

For each endpoint a corresponding bit is used to request that a buffer be prepared for an operation in order to respond to a USB transaction. Software

writes a 1 to the corresponding bit when posting a new transfer descriptor to an endpoint. Hardware will automatically use this bit to begin parsing for the new transfer descriptor. Hardware clears this bit when the associated endpoint(s) is (are) successfully primed.

Note: These bits will be momentarily set by hardware during hardware re-priming operations when a dTD is retired, and the dQH is updated.

| Field Name | Bits | Type | Reset Value | Description |
|------------|-------|------|-------------|--|
| PETB | 31:16 | wtc | 0x0 | Prime Endpoint TxBuffer (Device mode). Write a 1 to the corresponding bit to request TxBuffer to respond to a USB IN/INTERRUPT transaction. Bit[16]: Endpoint 0. Bit[17]: Endpoint 1. ... Bit[28]: Endpoint 12. Bits[31:29]: reserved. |
| PERB | 15:0 | wtc | 0x0 | Prime Endpoint RxBuffer (Device mode). Write a 1 to the corresponding bit to request RxBuffer to respond to a USB OUT transaction. Bit[0]: Endpoint 0. Bit[1]: Endpoint 1. ... Bit[12]: Endpoint 12. Bits[15:13]: reserved. |

Register ([usb](#)) XUSBPS_EPFLUSH_OFFSET

| | |
|------------------|--------------------------------------|
| Name | XUSBPS_EPFLUSH_OFFSET |
| Software Name | EPFLUSH |
| Relative Address | 0x000001B4 |
| Absolute Address | usb0: 0xE00021B4 usb1: 0xE00031B4 |
| Width | 32 bits |
| Access Type | wtc |
| Reset Value | 0x00000000 |
| Description | Endpoint Flush (Device mode) |

Register XUSBPS_EPFLUSH_OFFSET Details

The Flush operation of an endpoint will clear the usb.ENDPTSTAT bit and reset the RX/TX data buffer. Ready status of that endpoint and re-align the Latency Buffer pointers, but not clear the actual data that resides in the Latency Buffers.

Write a 1 to a bit(s) to cause the associated endpoint(s) to clear any primed buffers. If a packet is in progress for one of the associated endpoints, then that

transfer will continue until completion. Hardware will clear this register after the endpoint flush operation is successful.

| Field Name | Bits | Type | Reset Value | Description |
|------------|-------|------|-------------|---|
| FETB | 31:16 | wtc | 0x0 | Flush Endpoint TxBuffer (Device mode). Write a 1 to the corresponding bit to flush the TxBuffer. Bit[16]: Endpoint 0. Bit[17]: Endpoint 1. ... Bit[28]: Endpoint 12. Bits[31:29]: reserved. |
| FERB | 15:0 | wtc | 0x0 | Flush Endpoint RxBuffer (Device mode). Write a 1 to the corresponding bit to flush the RxBuffer. Bit[0]: Endpoint 0. Bit[1]: Endpoint 1. ... Bit[12]: Endpoint 12. Bits[15:13]: reserved. |

Register ([usb](#)) XUSBPS_EPRDY_OFFSET

| | |
|------|---------------------|
| Name | XUSBPS_EPRDY_OFFSET |
|------|---------------------|

| | |
|------------------|--|
| Software Name | EPRDY |
| Relative Address | 0x000001B8 |
| Absolute Address | usb0: 0xE00021B8 usb1: 0xE00031B8 |
| Width | 32 bits |
| Access Type | ro |
| Reset Value | 0x00000000 |
| Description | Endpoint Buffer Ready Status (Device mode), RO |

Register XUSBPS_EPRDY_OFFSET Details

For each endpoint, there is one buffer ready status (ENDPTSTAT) bit for the TX buffer and one bit for RX buffer.

An ENDPTSTAT bit is set to a 1 by the hardware in a response to receiving an EP prime command (write 1 to usb.ENDPTPRIME register). There will always be a delay between writing a 1 to a usb.ENDPTPRIME register bit and the ENDPTSTAT bit asserting to indicate ready. This delay time varies based upon the current USB traffic and the number of bits in the usb.ENDPTPRIME register that transition from 0 to 1.

An ENDPTSTAT bit is cleared in one of three ways: by a USB reset, by the DMA engine hardware, or by a flush command using the usb.ENDPTFLUSH register.

Note: The ENDPTSTAT bit will be momentarily read = 0 during the time the hardware is retiring a dTD and updating the dQH transfer descriptors.

| Field Name | Bits | Type | Reset Value | Description |
|------------|-------|------|-------------|--|
| ETBR | 31:16 | ro | 0x0 | TxBuffer ready status (Device mode), read-only. 0: cleared by reset, DMA, or ENDPTFLUSH. 1: ENDPTPRIME command received. Bit[16]: Endpoint 0. Bit[17]: Endpoint 1. ... Bit[28]: Endpoint 12. Bits[31:29]: reserved. |
| ERBR | 15:0 | ro | 0x0 | RxBuffer ready status (Device mode), read-only. 0: cleared by reset, DMA, or ENDPTFLUSH. 1: ENDPTPRIME command received. Bit[0]: Endpoint 0. Bit[1]: Endpoint 1. ... Bit[12]: Endpoint 12. Bits[15:13]: reserved. |

Register ([usb](#)) XUSBPS_EPCOMPL_OFFSET

| | |
|------------------|--------------------------------------|
| Name | XUSBPS_EPCOMPL_OFFSET |
| Software Name | EPCOMPL |
| Relative Address | 0x000001BC |
| Absolute Address | usb0: 0xE00021BC usb1: 0xE00031BC |
| Width | 32 bits |
| Access Type | rw |
| Reset Value | 0x00000000 |
| Description | Endpoint Tx Complete (Device mode) |

Register XUSBPS_EPCOMPL_OFFSET Details

Each bit indicates an event (Transmit/Receive) occurred and software should read the corresponding endpoint queue to determine the endpoint status. If the

corresponding IOC bit is set in the Transfer Descriptor, then this bit will be set simultaneously with the USBINT. Writing a 1 will clear the corresponding bit in this register.

| Field Name | Bits | Type | Reset Value | Description |
|------------|-------|------|-------------|--|
| ETCE | 31:16 | rw | 0x0 | Endpoint Transmit Complete Event (Device mode), read-only. 0: not completed. 1: completed. Write a 1 to clear. Bit[16]: Endpoint 0. Bit[17]: Endpoint 1. ... Bit[28]: Endpoint 12. Bits[31:29]: reserved. |
| ERCE | 15:0 | rw | 0x0 | Endpoint Receive Complete Event (Device mode), read-only. 0: not completed. 1: completed. Write a 1 to clear. Bit[0]: Endpoint 0. Bit[1]: Endpoint 1. ... Bit[12]: Endpoint 12. Bits[15:13]: reserved. |

Register ([usb](#)) XUSBPS_EPCRO_OFFSET

| | |
|---------------|---------------------|
| Name | XUSBPS_EPCRO_OFFSET |
| Software Name | EPCRO |

| | |
|------------------|--------------------------------------|
| Relative Address | 0x000001C0 |
| Absolute Address | usb0: 0xE00021C0 usb1: 0xE00031C0 |
| Width | 24 bits |
| Access Type | mixed |
| Reset Value | 0x00800080 |
| Description | Endpoint 0 (Device mode) |

Register XUSBPS_EPCR0_OFFSET Details

Every device controller implements Endpoint 0 as a control endpoint.

Rx and Tx Endpoint Stall bits [0] and [16]:

Software can write a one to a stall bit to force the endpoint to return a STALL handshake to the Host. The device controller will continue returning STALL until the bit is cleared by software or it will automatically be cleared upon receipt of a new SETUP request. After receiving a SETUP request, the stall bit will continue to be cleared by hardware until the associated ENDPTSETUPSTAT bit is cleared. Note: There is a slight delay (50 clocks max.) between the ENDPTSETUPSTAT being cleared and hardware continuing to clear this bit. In most systems it is unlikely the software will observe this delay. However, should the software observe that the stall bit is not set after writing a 1 to it then follow this procedure: continually write this stall bit until it is set or until a new SETUP has been received by checking the associated ENDPTSETUPSTAT bit.

| Field Name | Bits | Type | Reset Value | Description |
|---|-------|------|-------------|---|
| XUSBPS_EPCR_TXE_MASK (EPCR_TXE) | 23 | ro | 0x1 | Transmit Endpoint Enable, read-only. 1: EP 0 is always enabled. |
| reserved | 22:20 | ro | 0x0 | reserved |
| XUSBPS_EPCR_TXT_INTR_MASK (EPCR_TXT_INTR) | 19:18 | ro | 0x0 | TX Endpoint Type, read-only. 00: EP 0 is always a control endpoint. |
| reserved | 17 | ro | 0x0 | reserved |
| XUSBPS_EPCR_TXS_MASK (EPCR_TXS) | 16 | rw | 0x0 | TX Endpoint Stall, read-only. 0: Normal operation. 1: Force Stall handshake. Note: refer to the register description for more description. |
| reserved | 15:8 | ro | 0x0 | reserved |
| XUSBPS_EPCR_RXE_MASK (EPCR_RXE) | 7 | ro | 0x1 | RX Endpoint Enable, read-only. 1: EP 0 is always enabled. |
| reserved | 6:4 | ro | 0x0 | reserved |

| Field Name | Bits | Type | Reset Value | Description |
|--|------|------|-------------|--|
| XUSBPS_EPCR_RXT_INT R_MASK (EPCR_RXT_INTR) | 3:2 | ro | 0x0 | RX Endpoint Type, read-only. 00: EP0 is always a control endpoint. |
| reserved | 1 | ro | 0x0 | reserved |
| XUSBPS_EPCR_RXS_MA SK (EPCR_RXS) | 0 | rw | 0x0 | RX Endpoint Stall. 0: Normal operation. 1: Force Stall handshake. Note: refer to the register description for more description. |

Register ([usb](#)) ENDPTCTRL1

| | |
|------------------|--------------------------------------|
| Name | ENDPTCTRL1 |
| Relative Address | 0x000001C4 |
| Absolute Address | usb0: 0xE00021C4 usb1: 0xE00031C4 |
| Width | 24 bits |
| Access Type | mixed |
| Reset Value | 0x00000000 |
| Description | Endpoints 1 to 11 (Device mode) |

Note: This register is the first in an array of 11 identical registers listed in the table below. The details provided in this section apply to the entire array.

| Name | Address |
|-------------|------------|
| ENDPTCTRL1 | 0xe00021c4 |
| ENDPTCTRL2 | 0xe00021c8 |
| ENDPTCTRL3 | 0xe00021cc |
| ENDPTCTRL4 | 0xe00021d0 |
| ENDPTCTRL5 | 0xe00021d4 |
| ENDPTCTRL6 | 0xe00021d8 |
| ENDPTCTRL7 | 0xe00021dc |
| ENDPTCTRL8 | 0xe00021e0 |
| ENDPTCTRL9 | 0xe00021e4 |
| ENDPTCTRL10 | 0xe00021e8 |
| ENDPTCTRL11 | 0xe00021ec |

Register ENDPTCTRL1 to ENDPTCTRL11 Details

| Field Name | Bits | Type | Reset Value | Description |
|------------|-------|------|-------------|---|
| TXE | 23 | rw | 0x0 | TX Endpoint Enable. 0: disable. 1: enable. Enable an Endpoing after it has been configured. |
| TXR | 22 | rw | 0x0 | TX Data Toggle Reset. Write '1' will reset the PID sequence. Whenever a configuration event is received for this Endpoint, software must write a one to this bit in order to synchronize the data PID's between the host and device. |
| TXI | 21 | ro | 0x0 | TX Data Toggle Inhibit. (testing) 0: PID Sequencing enabled 1: PID Sequencing disabled |
| reserved | 20 | ro | 0x0 | reserved |
| TXT | 19:18 | rw | 0x0 | TX Endpoint Type control. 00: Control 01: Isochronous 10: Bulk 11: Interrupt |
| TXD | 17 | rw | 0x0 | TX Endpoint Data datapath. 0: dual-port memory buffer with a DMA Engine. Always write a 0. |
| TXS | 16 | rw | 0x0 | TX Endpoint Stall. 0: Normal operation. 1: Force Stall handshake. Note: refer to the ENDPTCTRL 0 register description for more description. |
| reserved | 15:8 | ro | 0x0 | reserved |
| RXE | 7 | rw | 0x0 | RX Endpoint Enable 0: Disable 1: Enable Enable an Endpoing after it has been configured. |
| RXR | 6 | rw | 0x0 | RX Data Toggle Reset. Write '1' will reset the PID sequence. Whenever a configuration event is received for this Endpoint, software must write a one to this bit in order to synchronize the data PID's between the host and device. |
| RXI | 5 | rw | 0x0 | RX Data Toggle Inhibit. 0: PID Sequencing enabled 1: PID Sequencing disabled |
| reserved | 4 | rw | 0x0 | reserved |

| Field Name | Bits | Type | Reset Value | Description |
|------------|------|------|-------------|--|
| RXT | 3:2 | rw | 0x0 | RX Endpoint Type. 00: Control 01: Isochronous 10: Bulk 11: Interrupt |
| RXD | 1 | rw | 0x0 | RX Endpoint Data datapath. 0: dual-port memory buffer with a DMA Engine. Always write a 0. |
| RXS | 0 | rw | 0x0 | RX Endpoint Stall. 0: Normal operation. 1: Force Stall handshake. Note: refer to the ENDPTCTRL 0 register description for more description. |

Access Types Legend

| Access Type | Description |
|-------------|---|
| clonrd | Readable, clears value on read |
| clonwr | Readable, clears value on write |
| nsnsro | During non-secure access, if thread is non-secure, it is read only |
| nsnsrw | During non-secure access, if thread is non-secure, it is read write |
| nsnswo | During non-secure access, if thread is non-secure, it is write only |
| nssraz | During non-secure access, if thread is secure, it is read as zero |
| raz | Read as zero |
| ro | Read-only |
| rs | w: no effect, r: sets all bits |
| rud | Read undefined |
| rw | Normal read/write |
| rws0 | Read/write, set only |
| sro | During secure access, it is read only |
| srw | During secure access, it is read write |
| swo | During secure access, it is write only |
| w0c | w: 1/0 no effect on/clears matching bit, r: no effect |
| w0crs | w: 1/0 no effect on/clears matching bit, r: sets all bits |
| w0s | w: 1/0 no effect on/sets matching bit, r: no effect |
| w0src | w: 1/0 no effect on/sets matching bit, r: clears all bits |
| w0t | w: 1/0 no effect on/toggles matching bit, r: no effect |
| w1 | w: first one after ~hard~ reset is as-is, other w have no effects, r: no effect |
| w1crs | w: 1/0 clears/no effect on matching bit, r: sets all bits |

| Access Type | Description |
|-------------|---|
| w1src | w: 1/0 sets/no effect on matching bit, r: clears all bits |
| w1t | w: 1/0 toggles/no effect on matching bit, r: no effect |
| waz | Write as zero |
| wcrs | w: clears all bits, r: sets all bits |
| wo | Write-only |
| wo1 | w: first one after ~hard~ reset is as-is, other w have no effects, r: error |
| woc | w: clears all bits, r: error |
| wos | w: sets all bits, r: error |
| wrc | w: as-is, r: clears all bits |
| wrs | w: as-is, r: sets all bits |
| ws | w: sets all bits, r: no effect |
| wsrc | w: sets all bits, r: clears all bits |
| wtc | Readable, write a 1 to clear |
| z | Access (read or write) as zero |