

LogiCORE IP Block Memory Generator v8.0

Product Guide for Vivado Design Suite

PG058 October 2, 2013

Table of Contents

IP Facts

Chapter 1: Overview

Feature Summary	5
Native Block Memory Generator Feature Summary	7
AXI4 Interface Block Memory Generator Feature Summary	10
Applications	25
Licensing and Ordering Information	26

Chapter 2: Product Specification

Performance	27
Resource Utilization	30
Port Descriptions	33

Chapter 3: Designing with the Core

General Design Guidelines	42
Clocking	77
Resets	77

Chapter 4: Customizing and Generating the Core

Vivado Integrated Design Environment (IDE)	78
Generating the AXI4 Interface Block Memory Generator Core	89
Output Generation	92

Chapter 5: Constraining the Core

Chapter 6: Simulation

Chapter 7: Synthesis and Implementation

Chapter 8: Detailed Example Design

Chapter 9: Test Bench

Core with Native Interface	98
Core with AXI4 Interface	98
Messages and Warnings	98

Appendix A: Verification, Compliance, and Interoperability

Simulation	99
------------------	----

Appendix B: Migrating and Updating

Migrating to the Vivado Design Suite	100
Upgrading in the Vivado Design Suite	100

Appendix C: Debugging

Finding Help on Xilinx.com	101
Debug Tools	102
Simulation Debug	103
Hardware Debug	103

Appendix D: Native Block Memory Generator Supplemental Information

Appendix E: Additional Resources

Xilinx Resources	121
References	121
Revision History	122
Notice of Disclaimer	122

Introduction

The Xilinx LogiCORE™ IP Block Memory Generator (BMG) core is an advanced memory constructor that generates area and performance-optimized memories using embedded block RAM resources in Xilinx FPGAs. Users can quickly create optimized memories to leverage the performance and features of block RAMs in Xilinx FPGAs.

The BMG core supports both Native and AXI4 interfaces.

The AXI4 interface configuration of the BMG core is derived from the Native interface BMG configuration and adds an industry-standard bus protocol interface to the core. Two AXI4 interface styles are available: AXI4 and AXI4-Lite.

Features

For details on the features of each interface, see [Feature Summary in Chapter 1](#).

LogiCORE IP Facts Table	
Core Specifics	
Supported Device Family ⁽¹⁾	Zynq®-7000, Artix®-7, Virtex®-7, Kintex®-7
Supported User Interfaces	AXI4, AXI4-Lite
Resources	See Resource Utilization .
Provided with Core	
Design Files	Encrypted RTL
Example Design	VHDL
Test Bench	VHDL
Constraints File	XDC
Simulation Model	Verilog and VHDL Behavioral ⁽²⁾
Supported S/W Driver	N/A
Tested Design Flows⁽³⁾	
Design Entry	Vivado® Design Suite IP Integrator
Simulation	For support simulators, see the Xilinx Design Tools: Release Notes Guide .
Synthesis	Vivado Synthesis
Support	
Provided by Xilinx @ www.xilinx.com/support	

Notes:

1. For a complete list of supported devices, see Vivado IP catalog.
2. Behavioral models do not precisely model collision behavior. See [Collision Behavior, page 54](#) for details.
3. For the supported versions of the tools, see the [Xilinx Design Tools: Release Notes Guide](#).

Overview

The Block Memory Generator core uses embedded Block Memory primitives in Xilinx FPGAs to extend the functionality and capability of a single primitive to memories of arbitrary widths and depths. Sophisticated algorithms within the Block Memory Generator core produce optimized solutions to provide convenient access to memories for a wide range of configurations.

The Block Memory Generator has two fully independent ports that access a shared memory space. Both A and B ports have a Write and a Read interface. In Zynq-7000 and 7 series FPGA architectures, each of the four interfaces can be uniquely configured with a different data width. When not using all four interfaces, the user can select a simplified memory configuration (for example, a Single-Port Memory or Simple Dual-Port Memory) to reduce FPGA resource utilization.

The Block Memory Generator is not completely backward-compatible with the discontinued legacy Single-Port Block Memory and Dual-Port Block Memory cores; for information about the differences, see [Appendix B, Migrating and Updating](#).

Feature Summary

Features Common to the Native Interface and AXI4 BMG Cores

- Optimized algorithms for minimum block RAM resource utilization or low power utilization
- Configurable memory initialization
- Individual Write enable per byte in Zynq™-7000, Kintex™-7, and Virtex®-7 with or without parity
- Optimized VHDL and Verilog behavioral models for fast simulation times; structural simulation models for precise simulation of memory behaviors
- Selectable operating mode per port: WRITE_FIRST, READ_FIRST, or NO_CHANGE
- Lower data widths for Zynq-7000 and 7 series devices in SDP mode
- VHDL example design and demonstration test bench demonstrating the IP core design flow, including how to instantiate and simulate it

Native Block Memory Generator Specific Features

- Generates Single-port RAM, Simple Dual-port RAM, True Dual-port RAM, Single-port ROM, and Dual-port ROM
- Supports memory sizes up to a maximum of 2 MBytes (byte size 8 or 9) (limited only by memory resources on selected part)
- Configurable port aspect ratios for dual-port configurations and Read-to-Write aspect ratios
- Supports the built-in Hamming Error Correction Capability (ECC). Error injection pins allow insertion of single and double-bit errors
- Supports soft Hamming Error Correction (Soft ECC) for data widths less than 64 bits
- Option to pipeline DOUT bus for improved performance in specific configurations
- Choice of reset priority for output registers between priority of SR (Set Reset) or CE (Clock Enable)
- Performance up to 450 MHz

AXI4 Interface Block Memory Generator Specific Features

- Supports AXI4 and AXI4-Lite interface protocols
- AXI4 compliant Memory and Peripheral Slave types
- Independent Read and Write Channels
- Zero delay datapath
- Supports registered outputs for handshake signals
- INCR burst sizes up to 256 data transfers
- WRAP bursts of 2, 4, 8, and 16 data beats
- AXI narrow and unaligned burst transfers
- Simple Dual-port RAM primitive configurations
- Performance up to 300 MHz
- Supports data widths up to 256 bits and memory depths from 1 to 128 k words (limited only by memory resources on selected part)
- Symmetric aspect ratios
- Asynchronous active low reset

Native Block Memory Generator Feature Summary

Memory Types

The Block Memory Generator core uses embedded block RAM to generate five types of memories:

- Single-port RAM
- Simple Dual-port RAM
- True Dual-port RAM
- Single-port ROM
- Dual-port ROM

For dual-port memories, each port operates independently. Operating mode, clock frequency, optional output registers, and optional pins are selectable per port. For Simple Dual-port RAM, the operating modes are not selectable. See [Collision Behavior, page 54](#) for additional information.

Selectable Memory Algorithm

The core configures block RAM primitives and connects them together using one of the following algorithms:

- **Minimum Area Algorithm:** The memory is generated using the minimum number of block RAM primitives. Both data and parity bits are utilized.
- **Low Power Algorithm:** The memory is generated such that the minimum number of block RAM primitives are enabled during a Read or Write operation.
- **Fixed Primitive Algorithm:** The memory is generated using only one type of block RAM primitive. For a complete list of primitives available for each device family, see the data sheet for that family.

Configurable Width and Depth

The Block Memory Generator can generate memory structures from 1 to 4608 bits wide, and at least two locations deep. The maximum depth of the memory is limited only by the number of block RAM primitives in the target device, as shown in [Table 1-1](#) through [Table 1-3](#).

Table 1-1: BMG Width and Depth (without Byte Write Enable)

Memory Width (bits)	Memory Depth (words)
Less than or equal to 128 (<=128)	Less than or equal to 128k (<=128k)
Greater than 128 and less than or equal to 256 (>128 and <=256)	Less than or equal to 64k (<=64k)
Greater than 256 and less than or equal to 512 (>256 and <=512)	Less than or equal to 32k (<=32k)
Greater than 512 and less than or equal to 1024 (>512 and <=1024)	Less than or equal to 16k (<=16k)
Greater than 1024 and less than or equal to 2048 (>1024 and <=2048)	Less than or equal to 8k (<=8k)
Greater than 2048 and less than or equal to 4608 (>2048 and <=4608)	Less than or equal to 4k (<=4k)

Table 1-2: BMG Width and Depth: Byte Size 8 with Byte Write Enable

Memory Width (bits)	Memory Depth (words)
Less than or equal to 128 (<=128)	Less than or equal to 128k (<=128k)
Greater than 128 and less than or equal to 256 (>128 and <=256)	Less than or equal to 64k (<=64k)
Greater than 256 and less than or equal to 512 (>256 and <=512)	Less than or equal to 32k (<=32k)
Greater than 512 and less than or equal to 1024 (>512 and <=1024)	Less than or equal to 16k (<=16k)
Greater than 1024 and less than or equal to 2048 (>1024 and <=2048)	Less than or equal to 8k (<=8k)
Greater than 2048 and less than or equal to 4096 (>2048 and <=4096)	Less than or equal to 4k (<=4k)

Table 1-3: BMG Width and Depth: Byte Size 9 with Byte Write Enable

Memory Width (bits)	Memory Depth (words)
Less than or equal to 144 (<=144)	Less than or equal to 128k (<=128k)
Greater than 128 and less than or equal to 288 (>144 and <=288)	Less than or equal to 64k (<=64k)
Greater than 288 and less than or equal to 576 (>288 and <=576)	Less than or equal to 32k (<=32k)
Greater than 576 and less than or equal to 1152 (>576 and <=1152)	Less than or equal to 16k (<=16k)
Greater than 1152 and less than or equal to 2304 (>1152 and <=2304)	Less than or equal to 8k (<=8k)
Greater than 2304 and less than or equal to 4608 (>2304 and <=4608)	Less than or equal to 4k (<=4k)

Selectable Operating Mode per Port

The Block Memory Generator supports the following block RAM primitive operating modes: WRITE FIRST, READ FIRST, and NO CHANGE. Each port may be assigned its own operating mode.

Selectable Port Aspect Ratios

The core supports the same port aspect ratios as the block RAM primitives:

- The A port width may differ from the B port width by a factor of 1, 2, 4, 8, 16, or 32.
- The Read width may differ from the Write width by a factor of 1, 2, 4, 8, 16, or 32 for each port. The maximum ratio between any two of the data widths (d_{ina} , d_{outa} , d_{inb} , and d_{outb}) is 32:1.

Optional Byte-Write Enable

The Block Memory Generator core provides byte-Write support for memory widths which are multiples of eight (no parity) or nine bits (with parity).

Optional Output Registers

The Block Memory Generator provides two optional stages of output registering to increase memory performance. The output registers can be chosen for port A and port B separately. The core supports embedded block RAM registers as well as registers implemented in the FPGA fabric. See [Output Register Configurations, page 114](#) for more information about using these registers.

Optional Pipeline Stages

The core provides optional pipeline stages within the MUX, available only when the registers at the output of the memory core are enabled and only for specific configurations. For the available configurations, the number of pipeline stages can be 1, 2, or 3. For detailed information, see [Optional Pipeline Stages, page 57](#).

Optional Enable Pin

The core provides optional port enable pins (ENA and ENB) to control the operation of the memory. When deasserted, no Read, Write, or reset operations are performed on the respective port. If the enable pins are not used, it is assumed that the port is always enabled.

Optional Set/Reset Pin

The core provides optional set/reset pins (`rst_a` and `rst_b`) for each port that initialize the Read output to a programmable value.

Memory Initialization

The memory contents can be optionally initialized using a memory coefficient (`COE`) file or by using the default data option. A `COE` file can define the initial contents of each individual memory location, while the default data option defines the initial content of all locations.

Note: When using IP Integrator, the initialization in BRAM Controller Mode is done only through the MEM file.

Hamming Error Correction Capability

Simple Dual-port RAM memories support the built-in FPGA Hamming Error Correction Capability (ECC) available block RAM primitives for data widths greater than 64 bits. The BuiltIn_ECC (ECC) memory automatically detects single- and double-bit errors, and is able to auto-correct the single-bit errors.

For data widths of 64 bits or less, a soft Hamming Error Correction implementation is available.

AXI4 Interface Block Memory Generator Feature Summary

Overview

AXI4 Interface Block Memories are built on the Native Interface Block Memories (see [Figure 1-1](#)). Two AXI4 interface styles are available - AXI4 and AXI4-Lite. The core can also be further classified as a Memory Slave or as a Peripheral Slave. In addition to applications supported by the Native Interface Block Memories, AXI4 Block Memories can also be used in AXI4 System Bus applications and Point-to-Point applications.

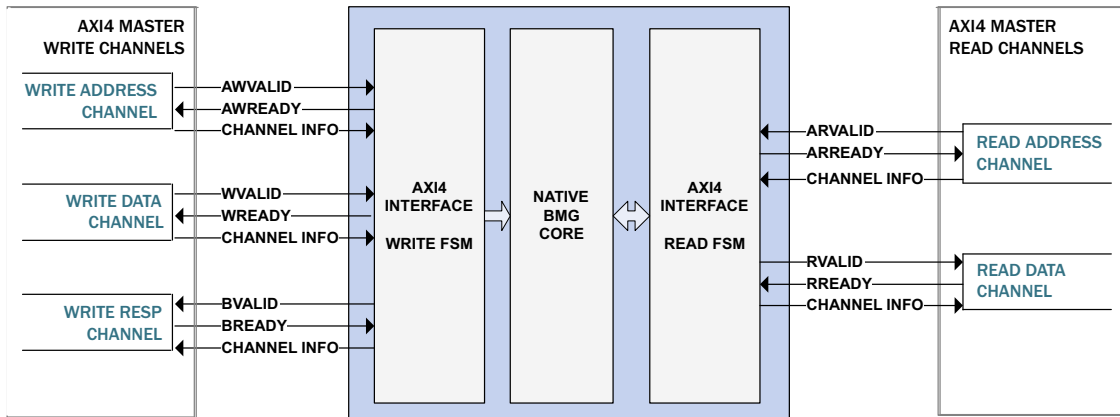

Figure 1-1: AXI4 Interface BMG Block Diagram

All communication in the AXI protocol is performed using five independent channels. Each of the five independent channels consists of a set of information signals and uses a two-way `valid` and `ready` handshake mechanism. The information source uses the `valid` signal to show when valid data or control information is available on the channel. The information destination uses the `ready` signal to show when it can accept the data.

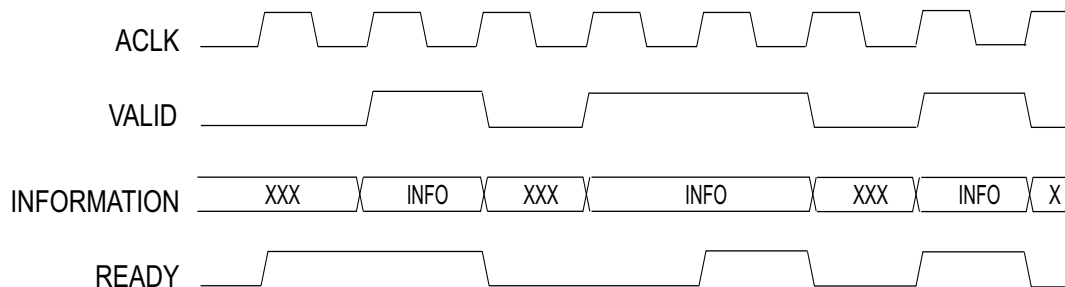

Figure 1-2: AXI4 Interface Handshake Timing Diagram

In [Figure 1-2](#), the information source generates the `valid` signal to indicate when data is available.

The destination generates the `ready` signal to indicate that it can accept the data, and transfer occurs only when both the `valid` and `ready` signals are high.

The AXI4 Block Memory Generator is an AXI4 endpoint Slave IP and can communicate with multiple AXI4 Masters in an AXI4 System or with Standalone AXI4 Masters in point to point applications. The core supports Simple Dual Port RAM configurations. Because AXI4 Block Memories are built using Native interface Block Memories, they share many common features.

All Write operations are initiated on the Write Address Channel (AW) of the AXI bus. The AW channel specifies the type of Write transaction and the corresponding address information. The Write Data Channel (W) communicates all Write data for single or burst Write

operations. The Write Response Channel (B) is used as the handshaking or response to the Write operation.

On Read operations, the Read Address Channel (AR) communicates all address and control information when the AXI master requests a Read transfer. When the Read data is available to send back to the AXI master, the Read Data Channel (R) transfers the data and status of the Read operation

Applications

AXI4 Block Memories - Memory Slave Mode

AXI4 Block Memories in Memory Slave mode are optimized for Memory Mapped System Bus implementations. The AXI4 Memory Slave Interface Type supports aligned, unaligned or narrow transfers for incremental or wrap bursts.

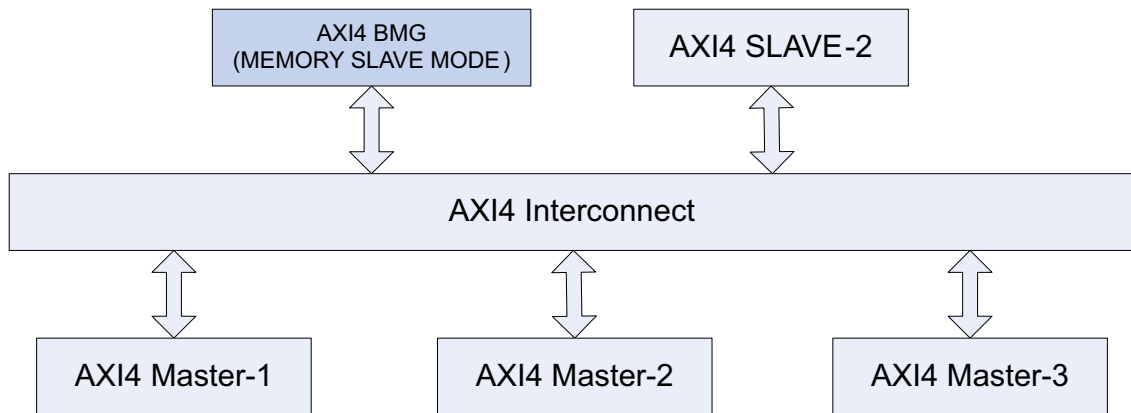

Figure 1-3: AXI4 Memory Slave Application Diagram

Figure 1-3 shows an example application for the AXI4 Memory Slave Interface Type with an AXI4 Interconnect for Multi Master AXI4 applications. Minimum memory requirement for this configuration is set to 4K bytes. Data widths supported by this configuration include 32, 64, 128 or 256 bits

AXI4-Lite Block Memories - Memory Slave Mode

AXI4-Lite Block Memories in Memory Slave mode are optimized for the AXI4-Lite interface. They can be used in implementations requiring simple Control/Status Accesses. AXI4-Lite Memory Slave Interface Type supports only single burst transactions.

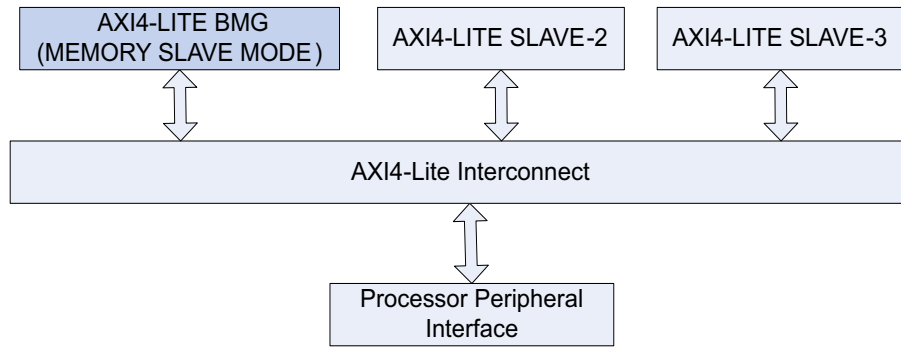

Figure 1-4: AXI4-Lite Memory Slave Application Diagram

Figure 1-4 shows an example application for AXI4-Lite Memory Slave Interface Type with an AXI4-Lite Interconnect to manage Control/Status Accesses. The minimum memory requirement for this configuration is set to 4K bytes. Data widths of 32 and 64 bits are supported by this configuration.

AXI4 Block Memories - Peripheral Slave Mode

AXI4 Block Memories in Peripheral Slave mode are optimized for a system or applications requiring data transfers that are grouped together in packets. The AXI4 Peripheral Slave supports aligned /unaligned addressing for incremental bursts.

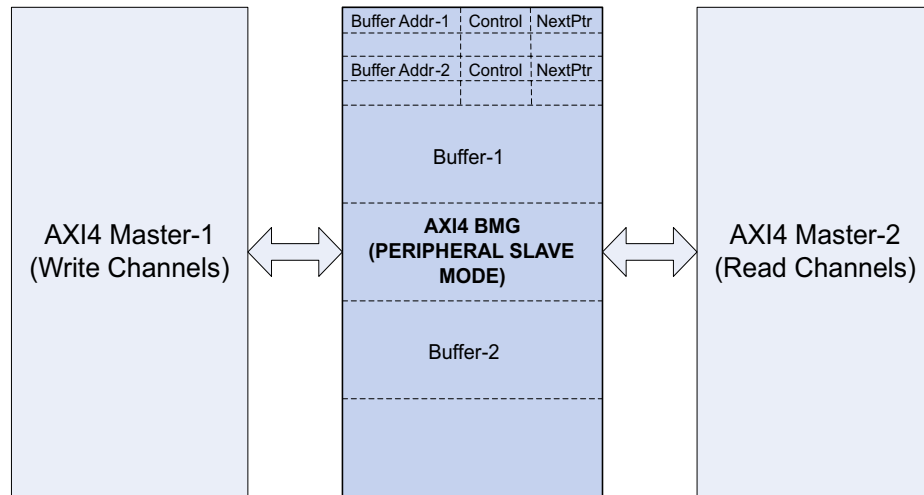

Figure 1-5: AXI4 Peripheral Slave Application Diagram

Figure 1-5 shows an example application for the AXI4 Peripheral Slave Interface Type in a Point-to-point buffered link list application. There is no minimum memory requirement set for this configuration. Data widths supported by this configuration include 8, 16, 32, 64, 128 and 256 bits.

AXI4-Lite Block Memories - Peripheral Slave Mode

AXI4-Lite Block Memories in Peripheral Slave mode are optimized for the AXI4-Lite interface. They can be used in implementations requiring single burst transactions.

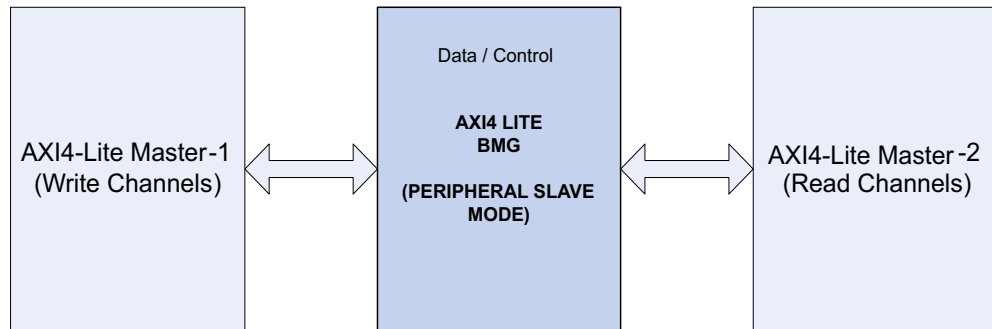

Figure 1-8: AXI4-Lite Peripheral Slave Application Diagram

Figure 1-8 shows an example application for the AXI4-Lite Memory Slave Interface Type in a Point-to-point application. There is no minimum memory requirement set for this configuration. Data widths supported by this configuration include 8, 16, 32 and 64 bits.

AXI4 BMG Core Channel Handshake Sequence

Figure 1-9 and Figure 1-10 illustrates an example handshake sequence for AXI4 BMG core. Figure 1-9 illustrates single burst Write operations to block RAM. By default the `awready` signal is asserted on the bus so that the address can be captured immediately during the clock cycle when both `awvalid` and `awready` are asserted. (With the default set in this manner, there is no need to wait an extra clock cycle `awready` to be asserted first.) By default, the `wready` signal will be de-asserted. Upon detecting `awvalid` being asserted, the `wready` signal will be asserted (AXI4 BMG core has registered an AXI Address and is ready to accept Data), and when `wvalid` is also asserted, writes will be performed to the block RAM. If the write data channel (`wvalid`) is presented prior to the write address channel valid (`awvalid`) assertion, the write transactions will not be initiated until the write address channel has valid information.

The AXI4 Block Memory core will assert `bvalid` for each transaction only after the last data transfer is accepted. The core also will not wait for the master to assert `BREADY` before asserting `bvalid`.

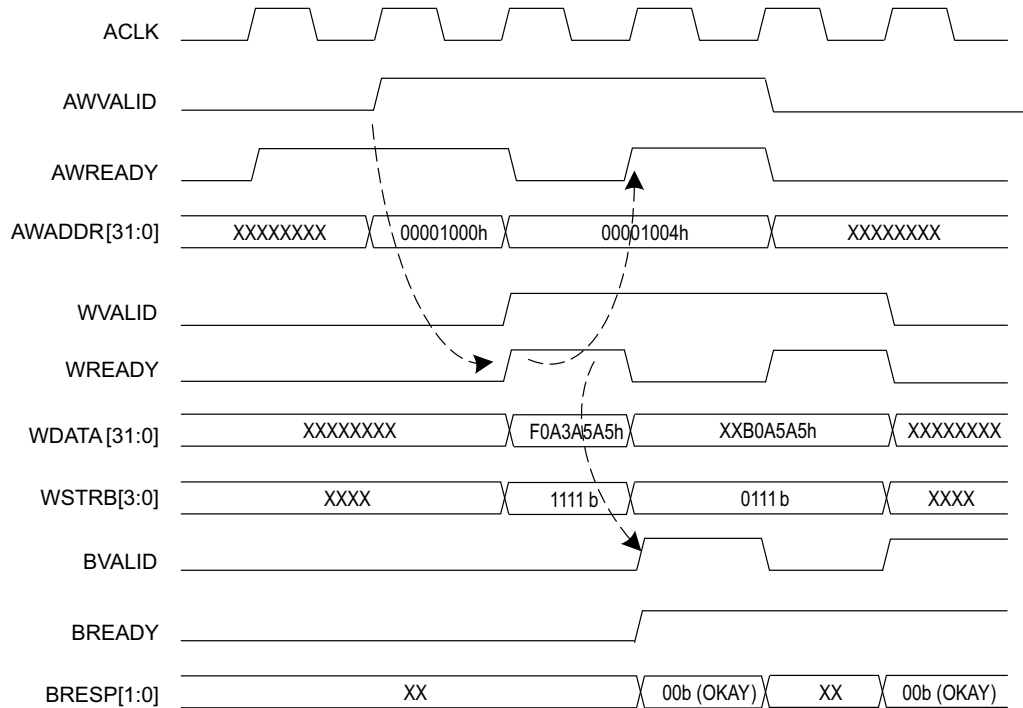

Figure 1-9: AXI4-Lite Single Burst Write Transactions

Figure 1-9 illustrates single burst Read operations to block RAM. The registered `arready` signal output on the AXI Read Address Channel interface defaults to a high assertion. The AXI Read FSM can accept the read address in the clock cycle where the `ARVALID` signal is first valid.

The AXI Read FSM can accept a same clock cycle assertion of the `RREADY` by the master if the master can accept data immediately. When the `RREADY` signal is asserted on the AXI bus by the master, the Read FSM will either negate the `RVALID` signal or will place next valid data on the AXI Bus.

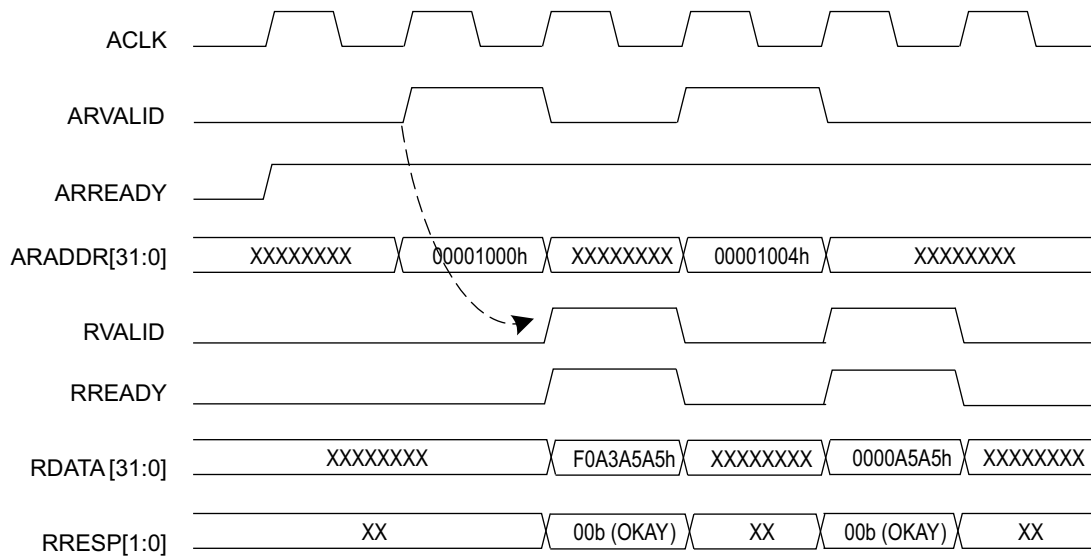

Figure 1-10: AXI4 Lite Single Burst Read Transactions

For more details on AXI4 Channel handshake sequences refer to the “Channel Handshake” section of the *AXI Protocol Specification* [Ref 1].

AXI4 Lite Single Burst Transactions

For AXI4 Lite interfaces, all transactions are burst length of one and all data accesses are the same size as the width of the data bus. Figure 1-9 and Figure 1-10 illustrates timing of AXI 32-bit write operations to the 32-bit wide BRAM. Figure 1-9 example illustrates single burst Write operations to block RAM addresses 0x1000h and 0x1004h. Figure 1-10 illustrates single burst Read operations to block RAM addresses 0x1000h and 0x1004h.

AXI4 Incremental Burst Support

Figure 1-11 illustrates an example of the timing for an AXI Write burst of four words to a 32-bit block RAM. The address Write channel handshaking stage communicates the burst type as INCR, the burst length of two data transfers ($AWLEN = 01h$). The Write burst utilizes all byte lanes of the AXI data bus going to the block RAM ($AWSIZE = 010b$).

In compliance with AXI Protocol, the burst termination boundary for a transaction is determined by the length specified in the $AWLEN$ signal. The allowable burst sizes for INCR bursts are from 1 (00h) to 256 (FFh) data transfers.

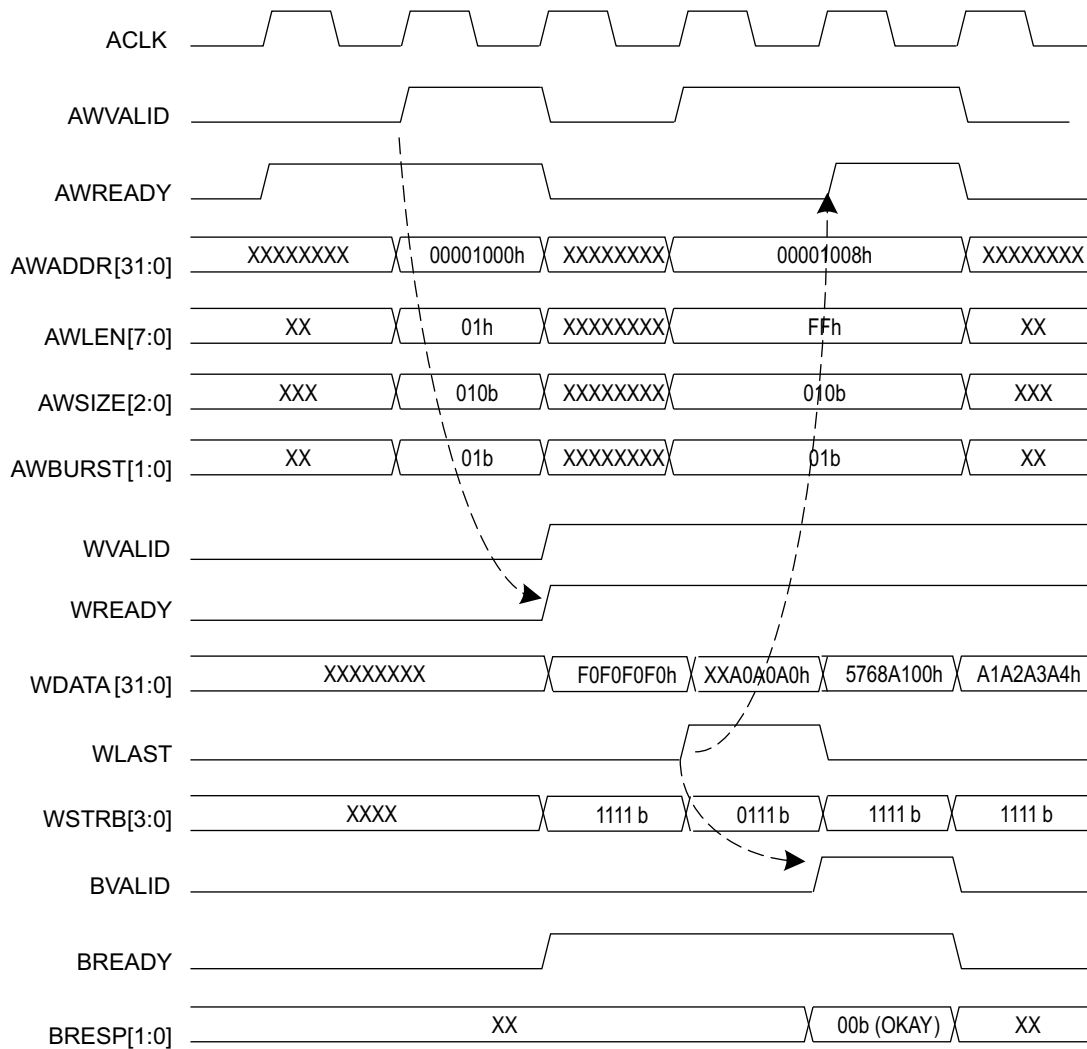

Figure 1-11: AXI4 Incremental Write Burst Transactions

Figure 1-12 illustrates the example timing for an AXI Read burst with block RAM managed by the Read FSM. The memory Read burst starts at address 0x1000h of the block RAM. On the AXI Read Data Channel, the Read FSM enables the AXI master/Interconnect to respond to the RVALID assertion when RREADY is asserted in the same clock cycle. If the requesting AXI master/Interconnect throttles on accepting the Read burst data (by negating RREADY), the Read FSM handles this by holding the data pipeline until RREADY is asserted.

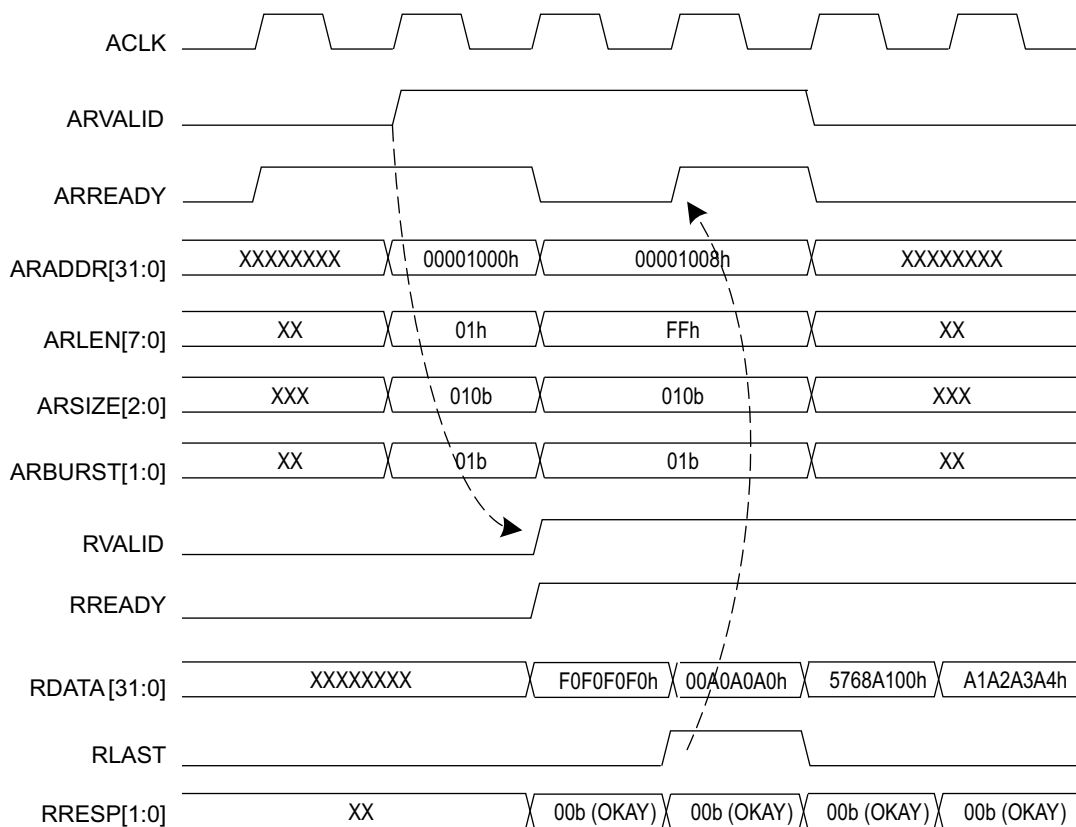

Figure 1-12: AXI4 Incremental Read Burst Transactions

AXI4 Wrap Burst Support

Cache line operations are implemented as WRAP burst types on AXI when presented to the block RAM. The allowable burst sizes for WRAP bursts are 2, 4, 8, and 16. The `AWBURST/ARBURST` must be set to "10" for the WRAP burst type.

WRAP bursts are handled by the address generator logic of the Write and Read FSM. The address seen by the block RAM must increment to the address space boundary, and then wrap back around to the beginning of the cache line address. For example, a processor issues a target word first cache line Read request to address 0x04h. On a 32-bit block RAM, the address space boundary is 0xFFh. So, the block RAM will see the following sequence of addresses for Read requests: 0x04h, 0x08h, 0x0Ch, 0x00h. Note the wrap of the cache line address from 0xCh back to 0x00h at the end.

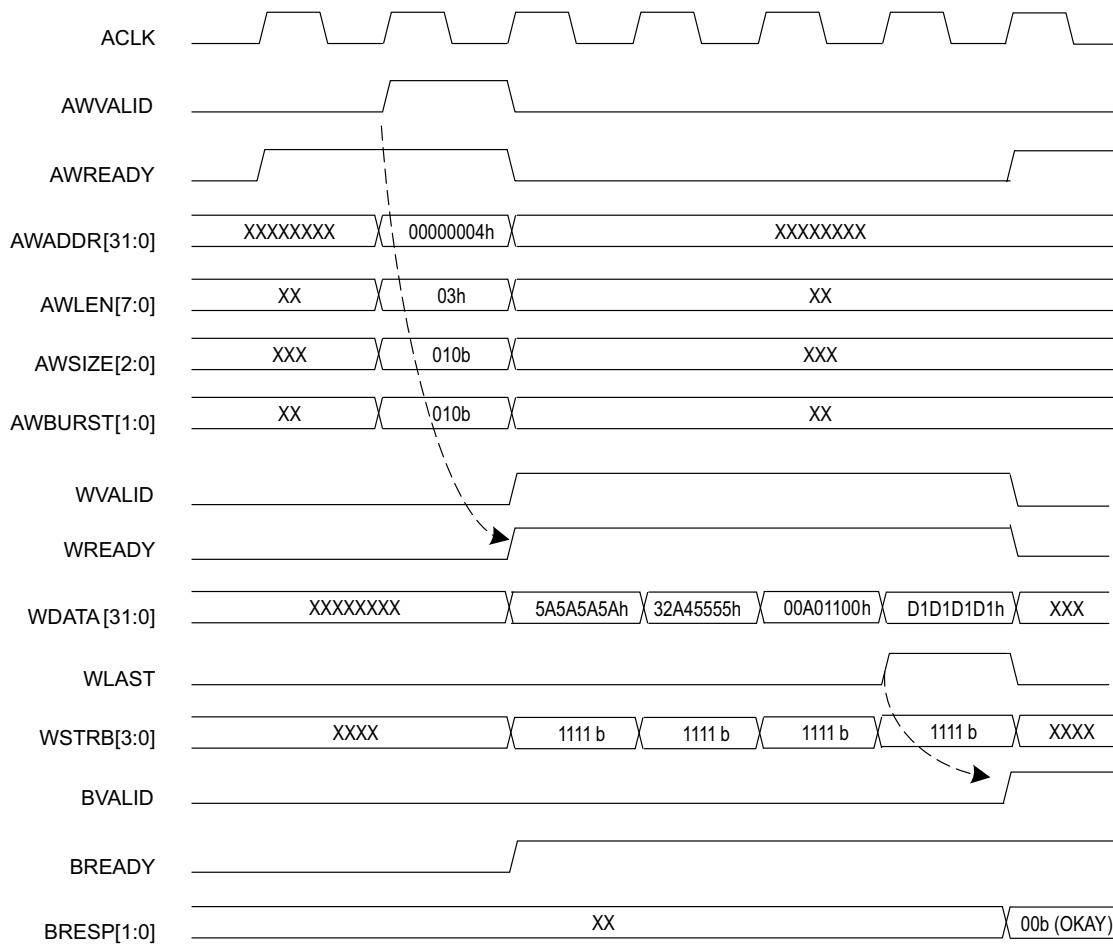

Figure 1-13: AXI4 Wrap Write Burst Transactions

Figure 1-13 illustrates the timing for AXI Wrap or cache line burst transactions. The address generated and presented to the block RAM starts at the target word and wraps around once the address space boundary is reached.

Figure 1-14 illustrates the timing on AXI WRAP or cache line burst Read transactions.

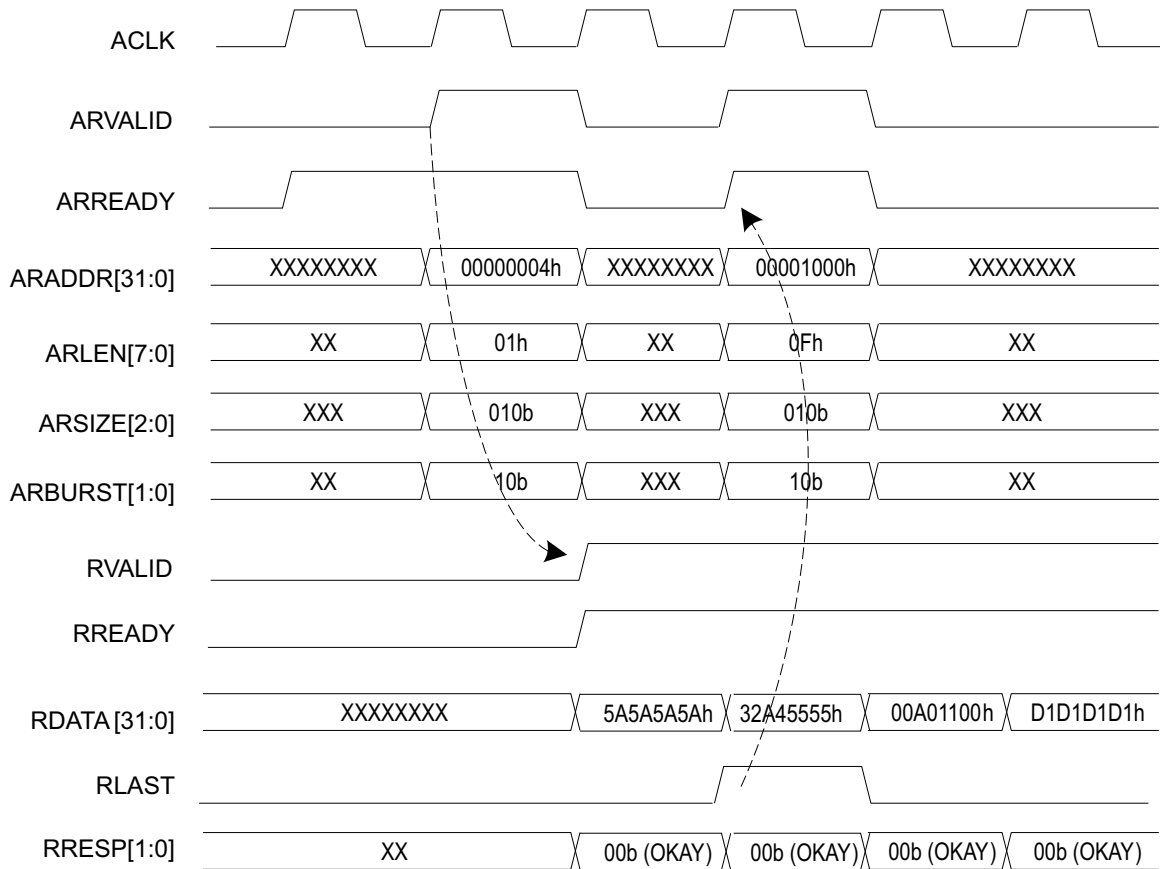

Figure 1-14: AXI4 Wrap Read Burst Transactions

Table 1-4 provides example address sequence to the block RAM for Wrap transactions.

Table 1-4: Example Address Sequence for AXI4 BMG Core Wrap Transactions

Memory Width	Transfer Size	Start Address	Burst Length	AXI4 BMG Core Address Sequence
32-bits	32-bits	0x100Ch	2	0x100Ch ⁽¹⁾ , 0x1008h
32-bits	32-bits	0x1008h	4	0x1008h, 0x100Ch ⁽¹⁾ , 0x1000h, 0x1004h
64-bits	64-bits	0x1008h	8	0x1008h, 0x1010h, 0x1018h, 0x1020h, 0x1028h, 0x1030h, 0x1038h ⁽¹⁾ , 0x1000h
64-bits	16-bits	0x1008h	16	0x1008h, 0x100Ah, 0x100Ch, 0x100Eh, 0x1010, 0x1012, 0x1014, 0x1016h, 0x1018h, 0x101Ah, 0x101Ch, 0x101Eh ⁽¹⁾ , 0x1000h, 0x1002h, 0x1004h, 0x1006h

1. Calculated Wrap Boundary address.

For more details on AXI4 Wrap Burst Transactions and Wrap boundary calculations, refer to the Burst Addressing section of the *AXI Protocol Specification* [Ref 1].

AXI4 Narrow Transactions

A narrow burst is defined as a master bursting a data size smaller than the block RAM data width. If the burst type (AWBURST) is set to INCR or WRAP, then the valid data on the block RAM interface to the AXI bus will rotate for each data beat. The Write and Read FSM handles each data beat on the AXI as a corresponding data beat to the block RAM, regardless of the smaller valid byte lanes. In this scenario, the AXI WSTRB is translated to the block RAM Write enable signals. The block RAM address only increments when the full address (data) width boundary is met with the narrow Write to block RAM.

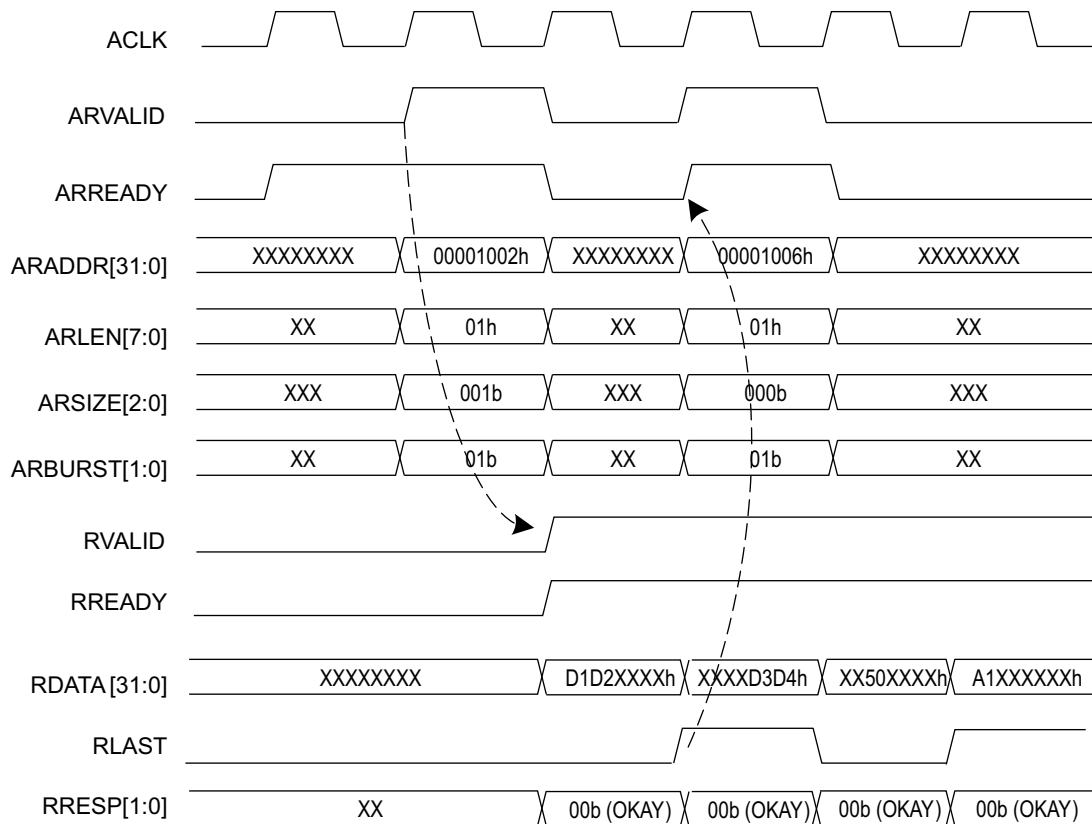

Figure 1-15: AXI4 Narrow Write Burst Transactions

Figure 1-15 illustrates an example of AXI narrow Write bursting with a 32-bit block RAM and the AXI master request is a half-word burst of four data beats. AWSIZE is set to 001b.

Figure 1-16 illustrates an example of AXI "narrow" Read bursting with a 32-bit block RAM and the AXI master request is a half-word burst of 4 data beats. ARSIZE is set to 001b.

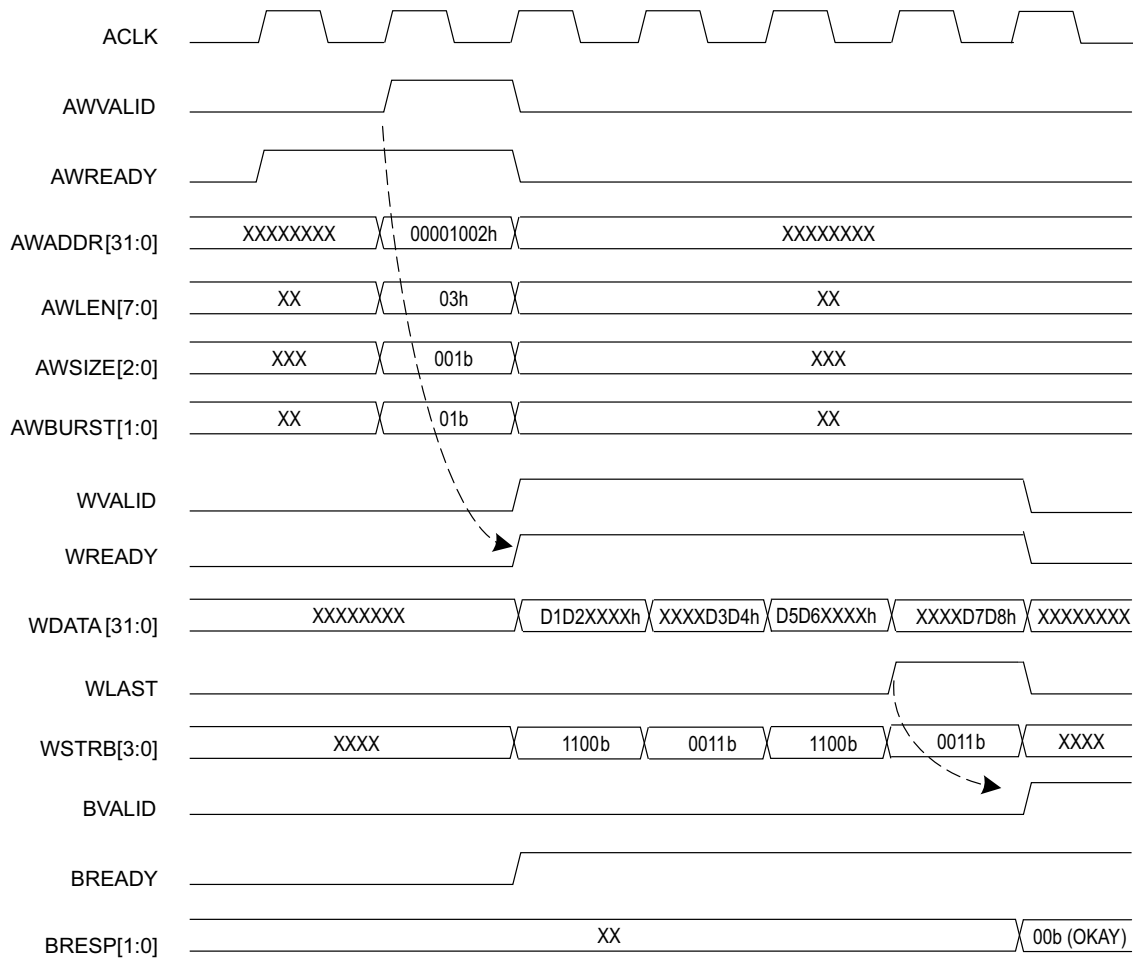

Figure 1-16: AXI4 Narrow Read Burst Transactions

For more details on AXI4 Narrow Transactions refer to the "Narrow transfers" section of the *AXI Protocol Specification* [Ref 1].

AXI4 Unaligned Transactions

Unaligned burst transfers for example, occur when a 32-bit word burst size does not start on an address boundary that matches a word memory location. The starting memory address is permitted to be something other than 0x0h, 0x4h, 0x8h, etc. The example shown in [Figure 1-17](#) illustrates an unaligned word burst transaction of 4 data beats, which starts at address offset, 0x1002h.

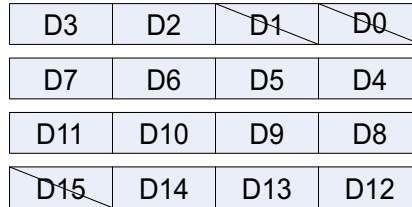

Figure 1-17: **AXI4 Unaligned Transactions**

For more details on AXI4 Narrow Transactions refer to the “about unaligned transfers” section of the *AXI Protocol Specification* [Ref 1].

Configurable Width and Depth

Table 1-5 provides supported Width and Depth for AXI4 Block Memory core.

Table 1-5: **Supported Width and Depth**

Operating Mode	Supported Memory Data Widths	Supported Minimum Memory Depth	
AXI4 Memory Slave	32,64,128, 256	Supports minimum 4kB address range:	
		<u>Data Width</u>	<u>Minimum Depth</u>
		32	1024
		64	512
AXI4 Lite Memory Slave	32,64	Supports minimum 4kB address range:	
		<u>Data Width</u>	<u>Minimum Depth</u>
		32	1024
AXI4 Peripheral Slave	8, 16, 32,64,128, 256	2	
		2	
AXI4 Lite Peripheral Slave	8, 16, 32,64,	2	

For Peripheral Slave configurations, there is no minimum requirement for the number of address bits used by Block Memory core. For Memory Slave configuration, AXI4 Block Memory slave has at least sufficient address bits to fully decode a 4kB address range.

For Peripheral Slave and AXI4 Lite Memory Slave configurations, AXI4 Block Memory core is not required to have low-order address bits to support decoding within the width of the system data bus and assumes that such low-order address bits have a default value of all zeros. For AXI4 Memory Slave configuration, AXI4 Block Memory core supports Narrow Transactions and performs low-order address bits decoding. For more details, see [AXI4 Interface Block Memory Addressing](#).

AXI4 Interface Block Memory Addressing

AXI4 Interface Block Memory cores support 32-bit byte addressing. There is no minimum requirement for the number of address bits supplied by a master. Typically a master is expected to supply 32-bits of addressing. [Table 1-6](#) illustrates some example settings to create a specific size of block RAM in the system.

Table 1-6: AXI4 Interface Block Memory Generator Example Address Ranges

Memory Width x Depth	Memory Size	Address Range Required	Example Base Address	Example Max Address	Block RAM Address
8 x 4096	4K	0x0000_0000 to 0x0000_0FFF	0xA000 0000	0xA000 0FFF	AXI_ADDR[11:0]
16 x 2048	4K	0x0000_0000 to 0x0000_0FFF	0xA000 0000	0xA000 0FFF	AXI_ADDR[11:1]
32 x 1024	4K	0x0000_0000 to 0x0000_0FFF	0xA000 0000	0xA000 0FFF	AXI_ADDR[11:2]
64 x 1024	8K	0x0000_0000 to 0x0000_1FFF	0x2400 0000	0x2400 1FFF	AXI_ADDR[12:3]
128 x 1024	16K	0x0000_0000 to 0x0000_3FFF	0x1F00 0000	0x1F00 3FFF	AXI_ADDR[13:4]
256 x 1024	32K	0x0000_0000 to 0x0000_7FFF	0x3000 0000	0x3000 7FFF	AXI_ADDR[14:5]

The Address Range of AXI Block Memory core must always start at zero. If the master has a different address bus width than that provided by the AXI4 Block Memory Core, follow these guidelines:

- If the Master address is wider than the configured Address Range for AXI Block Memory core, the additional high-order address bits can be connected as is. AXI Block Memory core will ignore these bits.
- If the Master address is narrower than 32-bits, the high-order address bits of the AXI Block Memory core can be left unconnected.

For more details on AXI4 Addressing refer to the “Master Addresses” and “Slave Addresses” section of the *AXI Protocol Specification* [\[Ref 1\]](#).

Throughput & Performance

To achieve 100 percent block RAM interface utilization of the Write port the following conditions must be satisfied.

- No single Write bursts.
- The AXI Master should not apply back pressure on the Write response channel

To achieve 100 percent block RAM interface utilization of the Read port the following conditions must be satisfied.

- The AXI Master should not apply back pressure on the Read data channel

Selectable Port Aspect Ratios

The core currently supports only symmetric aspect ratios (that is, a 1:1 aspect ratio only).

Optional Output Register

The Output Register option is currently not supported.

Optional Pipeline Stages

Pipeline stages are currently not supported.

Memory Initialization Capability

The memory contents can be optionally initialized using a memory coefficient (COE) file or by specifying a default data value. A COE file can define the initial contents of each individual memory location, while the default data value option defines the initial content for all locations.

Memory Initialization is not supported when ECC is enabled.

Applications

The Block Memory Generator core is used to create customized memories to suit any application. Typical applications include:

- **Single-port RAM:** Processor scratch RAM, look-up tables
- **Simple Dual-port RAM:** Content addressable memories, FIFOs
- **True Dual-port RAM:** Multi-processor storage
- **Single-port ROM:** Program code storage, initialization ROM
- **Dual-port ROM:** Single ROM shared between two processors/systems

Licensing and Ordering Information

This Xilinx LogiCORE IP module is provided under the terms of the [Xilinx Core License Agreement](#). The module is shipped as part of the Vivado Design Suite. For full access to all core functionalities in simulation and in hardware, you must purchase a license for the core. Contact your [local Xilinx sales representative](#) for information about pricing and availability.

For more information, visit the [Block Memory Generator product page](#).

Information about other Xilinx LogiCORE IP modules is available at the [Xilinx Intellectual Property](#) page. For information on pricing and availability of other Xilinx LogiCORE IP modules and tools, contact your [local Xilinx sales representative](#).

Product Specification

This chapter includes details on performance and latency.

Performance

Performance and resource utilization for a BMG varies depending on the configuration and features selected during core customization.

Table 2-1: Single Primitive Examples

Memory Type	Options	Width x Depth	Performance (MHz)
Artix-7 FPGAs			
True Dual-port RAM	No Output Registers	36x512	288
		9x2k	288
	Embedded Output Registers	36x512	382
		9x2k	382
Kintex-7 FPGAs			
True Dual-port RAM	No Output Registers	36x512	344
		9x2k	368
	Embedded Output Registers	36x512	382
		9x2k	454
Virtex-7 FPGAs			
True Dual-port RAM	No Output Registers	36x512	336
		9x2k	352
	Embedded Output Registers	36x512	454
		9x2k	454

Table 2-2: Output Register Examples

Memory Type	Width x Depth	Output Register Options	Performance (MHz)
Artix-7 FPGAs			
Single-port RAM	17x5k	No Primitive or Core	281
		Primitive	382
		Core	274
		Primitive and Core	382
True Dual-port RAM	17x5k	No Primitive or Core	274
		Primitive	274
		Core	281
		Primitive and Core	274
Kintex-7 FPGAs			
Single-port RAM	17x5k	No Primitive or Core	344
		Primitive	454
		Core	344
		Primitive and Core	454
True Dual-port RAM	17x5k	No Primitive or Core	336
		Primitive	336
		Core	
		Primitive and Core	344
Virtex-7 FPGAs			
Single-port RAM	17x5k	No Primitive or Core	336
		Primitive	454
		Core	344
		Primitive and Core	454
True Dual-port RAM	17x5k	No Primitive or Core	336
		Primitive	328
		Core	328
		Primitive and Core	336

Table 2-3: Memory Algorithm Examples

Memory Type	Width x Depth	Algorithm Type	Performance (MHz)
Artix-7 FPGAs			

Table 2-3: Memory Algorithm Examples (Cont'd)

Memory Type	Width x Depth	Algorithm Type	Performance (MHz)
Single-port RAM	17x5k	Minimum area	281
		Fixed Primitive using 18x1k block RAM	266
		Low power	258
	36x4k	Minimum area	312
		Fixed Primitive using 36x512 block RAM	258
		Low power	234
Kintex-7			
Single-port RAM	17x5k	Minimum area	344
		Fixed Primitive using 18x1k block RAM	328
		Low power	320
	36x4k	Minimum area	382
		Fixed Primitive using 36x512 block RAM	320
		Low power	304
Virtex-7 FPGAs			
Single-port RAM	17x5k	Minimum area	336
		Fixed Primitive using 18x1k block RAM	328
		Low power	312
	36x4k	Minimum area	368
		Fixed Primitive using 36x512 block RAM	304
		Low power	296

Table 2-4: AXI4 Examples

Memory Type	Options	Width x Depth	Performance (MHz)
Artix-7 FPGAs			
Simple Dual Port RAM	Memory Slave	32x1024	226
		64x512	234
	Peripheral Slave	32x1024	266
		64x512	274
Kintex-7 FPGAs			

Table 2-4: AXI4 Examples (Cont'd)

Memory Type	Options	Width x Depth	Performance (MHz)
Simple Dual Port RAM	Memory Slave	32x1024	344
		64x512	328
	Peripheral Slave	32x1024	360
		64x512	352
Virtex-7 FPGAs			
Simple Dual Port RAM	Memory Slave	32x1024	320
		64x512	274
	Peripheral Slave	32x1024	360
		64x512	344

Latency

The latency of output signals of BMG varies for different configurations. See [Optional Output Registers](#), [Optional Pipeline Stages](#), and [Memory Output Flow Control](#) in Chapter 3 for more details.

Resource Utilization

The following tables show resource utilization data and maximum performance values for a variety of sample BMG configurations.

Native Block Memory Generator

Note: Benchmarking data for Artix-7 and Kintex-7 devices will be available in future release.

The following tables provide examples of actual resource utilization and performance for Native Block Memory Generator implementations. Each section highlights the effects of a specific feature on resource utilization and performance. The actual results obtained will depend on core parameter selections, such as algorithm, optional output registers, and memory size, as well as surrounding logic and packing density.

Benchmarks were taken using a design targeting a Virtex-7 FPGA in the -1 speed grade (XC7VX550T-FFG1927-1). All benchmarks were obtained using the Vivado Design Suite.

In the benchmark designs described below, the core was encased in a wrapper with input and output registers to remove the effects of IO delays from the results; performance may vary depending on the user design. The minimum area algorithm was used unless otherwise noted. It is recommended that users register their inputs to the core for better performance.

The following examples highlight the use of embedded registers in 7 series devices, and the subsequent performance improvement that may result.

Single Primitive

The Block Memory Generator does not add additional logic if the memory can be implemented in a single Block RAM primitive. Table 2-5 through Table 2-7 define performance data for single-primitive memories.

Table 2-5: Single Primitive Examples - Virtex-7 FPGAs

Memory Type	Options	Width x Depth	Resource Utilization				
			Block RAMs		Shift Regs	FFs	LUTs ^a
			36K	18K			
True Dual-port RAM	No Output Registers	36x512	1	0	0	0	0
		9x2k	1	0	0	0	0
	Embedded Output Registers	36x512	1	0	0	0	0
		9x2k	1	0	0	0	0

a. LUTs are reported as the number of 6-input LUTs, and do not reflect the number of LUTs used as a route-through.

Output Registers

The Block Memory Generator optional output registers increase the performance of memories by isolating the block RAM primitive clock-to-out delays and the data output multiplexer delays.

The output registers are only implemented for output ports. For this reason, when output registers are used, a Single-port RAM requires fewer resources than a True Dual-port RAM. Note that the effects of the core output registers are not fully illustrated due to the simple register wrapper used. In a full-scale user design, core output registers may improve performance notably.

In Zynq-7000 and 7 series architectures, the embedded block RAM may be utilized, reducing the FPGA fabric resources required to create the registers.

Table 2-6: Virtex-7 Device Output Register Examples

Memory Type	Width x Depth	Output Register Options	Block RAM			FFs	LUTs ^a
			36K	16K	8K		
Single-port RAM	17x5k		1	3	0	3	18
		Primitive	1	3	0	6	18
		Core	1	3	0	20	18
		Primitive, Core	1	3	0	23	18

Table 2-6: Virtex-7 Device Output Register Examples (Cont'd)

Memory Type	Width x Depth	Output Register Options	Block RAM			FFs	LUTs ^a
			36K	16K	8K		
True Dual-port RAM	17x5k		1	3	0	6	36
		Primitive	1	3	0	9	36
		Core	1	3	0	23	36
		Primitive, Core	1	3	0	26	36

a. LUTs are reported as the number of 6-input LUTs, and do not reflect the number of LUTs used as a route-through.

Aspect Ratios

The Block Memory Generator selectable port and data width aspect ratios may increase block RAM usage and affect performance, because aspect ratios limit the primitive types available to the algorithm, which can reduce packing efficiency. Large aspect ratios, such as 1:32, have a greater impact than small aspect ratios. Note that width and depth are reported with respect to the port A Write interface.

Table 2-7: Virtex-7 Device Aspect Ratio

Memory Type	Width x Depth	Data Width Aspect Ratio	Block RAMs			FFs	LUTs ^a
			36K	16K	8K		
Single-port RAM	17x5k	1:1	2	3	0	6	36
		1:8 ^b	8	1	0	0	0

a. LUTs are reported as the number of 6-input LUTs, and do not reflect the number of LUTs used as a route-through.

b. Read port is 136x640; Write port is 17x5k.

Algorithm

The differences between the minimum area, low power and fixed primitive algorithms are discussed in detail in [Selectable Memory Algorithm, page 7](#). Table 2-8 shows examples of the resource utilization and the performance difference between them for two selected configurations for Virtex-7 FPGA architectures.

Table 2-8: Memory Algorithm Examples Virtex-7 Devices

Memory Type	Width x Depth	Algorithm Type	Block RAM			FFs	LUTs ^a
			36K	16K	8K		
Single-port RAM	17x5k	Minimum area	1	3	0	3	18
		Fixed Primitive using 18x1k block RAM	2	1	0	3	20
		Low power	0	5	0	3	38
	36x4k	Minimum area	4	0	0	0	0
		Fixed Primitive using 36x512 block RAM	4	0	0	2	40
		Low power	4	0	0	3	77

a. LUTs are reported as the number of 6-input LUTs, and do not reflect the number of LUTs used as a route-through.

AXI4 Block Memory Generator

Table 2-9 shows the resource utilization and performance data for a BMG core using the AXI4 interface. Benchmarks were taken using a design targeting a Virtex-7 FPGA in the -1 speed grade (XC7VX550T-FFG1927-1). All benchmarks were obtained using the Vivado Design Suite.

In the benchmark designs, the core was encased in a wrapper with input and output registers to remove the effects of I/O delays from the results. Performance may vary depending on the design.

Table 2-9: AXI4 Block Memory Generator Virtex-7 FPGA

Memory Type	Options	Width X Depth	Resource Utilization					
			Block RAMs			FFs	LUTs	Occupied Slices
			36K	16K	8K			
Simple Dual Port RAM	Memory Slave	32x1024	1	0	0	102	163	48
		64x512	1	0	0	103	174	69
	Peripheral Slave	32x1024	1	0	0	50	100	34
		64x512	1	0	0	48	99	35

Port Descriptions

Native Block Memory Generator Signals

Table 2-10 provides a description of the Block Memory Generator core signals. The widths of the data ports (*dina*, *douta*, *dinb*, and *doutb*) are selected by the user in the GUI. The

address port (addr_a and addr_b) widths are determined by the memory depth with respect to each port, as selected by the user in the GUI. The Write enable ports (we_a and we_b) are busses of width 1 when byte-writes are disabled. When byte-writes are enabled, we_a and we_b widths depend on the byte size and Write data widths selected in the GUI.

Table 2-10: Core Signal Pinout

Name	Direction	Description
clka	Input	Port A Clock: Port A operations are synchronous to this clock. For synchronous operation, this must be driven by the same signal as CLKB.
addr _a	Input	Port A Address: Addresses the memory space for port A Read and Write operations. Available in all configurations.
din _a	Input	Port A Data Input: Data input to be written into the memory via port A. Available in all RAM configurations.
dout _a	Output	Port A Data Output: Data output from Read operations via port A. Available in all configurations except Simple Dual-port RAM.
ena	Input	Port A Clock Enable: Enables Read, Write, and reset operations via port A. Optional in all configurations.
we _a	Input	Port A Write Enable: Enables Write operations via port A. Available in all RAM configurations.
rsta	Input	Port A Set/Reset: Resets the Port A memory output latch or output register. Optional in all configurations.
regcea	Input	Port A Register Enable: Enables the last output register of port A. Optional in all configurations with port A output registers.
clkb	Input	Port B Clock: Port B operations are synchronous to this clock. Available in dual-port configurations. For synchronous operation, this must be driven by the same signal as CLKA.
addr _b	Input	Port B address: Addresses the memory space for port B Read and Write operations. Available in dual-port configurations.
din _b	Input	Port B Data Input: Data input to be written into the memory via port B. Available in True Dual-port RAM configurations.
dout _b	Output	Port B Data Output: Data output from Read operations via Port B. Available in dual-port configurations.
enb	Input	Port B Clock Enable: Enables Read, Write, and reset operations via Port B. Optional in dual-port configurations.
we _b	Input	Port B Write Enable: Enables Write operations via Port B. Available in Dual-port RAM configurations.
rstb	Input	Port B Set/Reset: Resets the Port B memory output latch or output register. Optional in all configurations.
regceb	Input	Port B Register Enable: Enables the last output register of port B. Optional in dual-port configurations with port B output registers.
sbiterr	Output	Single-Bit Error: Flags the presence of a single-bit error in memory which has been auto-corrected on the output bus.

Table 2-10: Core Signal Pinout (Cont'd)

Name	Direction	Description
dbiterr	Output	Double-Bit Error: Flags the presence of a double-bit error in memory. Double-bit errors cannot be auto-corrected by the built-in ECC decode module.
injectsbiterr	Input	Inject Single-Bit Error: Available only for Zynq-7000 and 7 series ECC configurations.
injectdbiterr	Input	Inject Double-Bit Error: Available only for Zynq-7000 and 7 series ECC configurations.
rdadrecc	Output	Read Address for ECC Error output: Available only for Zynq-7000 and 7 series ECC configurations.

AXI4 Interface Block Memory Generator Signals

AXI4 Interface - Global Signals

Table 2-11: AXI4 or AXI4-Lite- Global Interface Signals

Name	Direction	Description
AXI4 or AXI4-Lite Global Interface Signals		
s_aclk	Input	Global Slave Interface Clock: All signals are sampled on the rising edge of this clock.
s_aresetn	Input	Global Reset: This signal is active low.

AXI4-Interface Signals

Table 2-12: AXI4 Write Channel Interface Signals

Name	Direction	Description
AXI4 Write Address Channel Interface Signals		
s_axi_awid[m:0]	Input	Write Address ID: This signal is the identification tag for the Write address group of signals. Write address ID is optional for Memory Slave configuration and is not supported for Peripheral Slave configuration.
s_axi_awaddr[31:0]	Input	Write Address: The Write address bus gives the address of the first transfer in a Write burst transaction. The associated control signals are used to determine the addresses of the remaining transfers in the burst.
s_axi_awlen[7:0]	Input	Burst Length: The burst length gives the exact number of transfers in a burst. This information determines the number of data transfers associated with the address.
s_axi_awsz[2:0]	Input	Burst Size: This signal indicates the size of each transfer in the burst. Byte lane strobes indicate exactly which byte lanes to update. Burst size should always be less than or equal to the width of the Write Data. Burst Size input is not supported for Peripheral Slave configuration.

Table 2-12: AXI4 Write Channel Interface Signals (Cont'd)

Name	Direction	Description
s_axi_awburst[1:0]	Input	<p>Burst Type: The burst type, coupled with the size information, details how the address for each transfer within the burst is calculated.</p> <p>Burst type for Memory Slave configuration could be either incremental or wrap.</p> <p>Burst type input is not supported for Peripheral Slave configuration, Burst type for Peripheral Slave is always internally set to incremental.</p>
s_axi_awvalid	Input	<p>Write Address Valid: This signal indicates that valid Write address and control information are available:</p> <ul style="list-style-type: none"> • 1 = address and control information available. • 0 = address and control information not available. The address and control information remain stable until the address acknowledge signal, awready, goes High.
s_axi_awready	Output	<p>Write Address Ready: This signal indicates that the slave is ready to accept an address and associated control signals:</p> <ul style="list-style-type: none"> • 1 = Slave ready • 0 = Slave not ready
AXI4 Write Data Channel Interface Signals		
s_axi_wdata[m-1:0]	Input	<p>Write Data: For Memory Slave configurations, the Write data bus can be 32, 64, 128, or 256 bits wide. For Peripheral Slave configurations, the Write data bus can be 8, 16, 32, 64, 128, or 256 bits wide.</p>
s_axi_wstrb[m/8-1:0]	Input	<p>Write Strobes: This signal indicates which byte lanes to update in memory. There is one Write strobe for each eight bits of the Write data bus. Therefore, WSTRB[n] corresponds to WDATA[(8 × n) + 7:(8 × n)].</p>
s_axi_wlast	Input	<p>Write Last: This signal indicates the last transfer in a Write burst.</p>
s_axi_wvalid	Input	<p>Write Valid: This signal indicates that valid Write data and strobes are available:</p> <ul style="list-style-type: none"> • 1 = Write data and strobes available • 0 = Write data and strobes not available
s_axi_wready	Output	<p>Write Ready: This signal indicates that the slave can accept the Write data:</p> <ul style="list-style-type: none"> • 1 = slave ready • 0 = slave not ready
AXI4 Write Response Channel Interface Signals		
s_axi_bid[m:0]	Output	<p>Response ID: The identification tag of the Write response. The BID value must match the AWID value of the Write transaction to which the slave is responding.</p> <p>Response ID is optional for Memory Slave configuration and is not supported for Peripheral Slave configuration.</p> <p>Response ID can be 1 to 16 bits wide.</p>

Table 2-12: AXI4 Write Channel Interface Signals (Cont'd)

Name	Direction	Description
s_axi_bresp[1:0]	Output	Write Response: This signal indicates the status of the Write transaction. The allowable responses are OKAY, EXOKAY, SLVERR, and DECERR. Write response is always set to OKAY. Write response is generated only when AXI4 ID is enabled for Memory Slave. Write response is not supported for Peripheral Slave configuration.
s_axi_bvalid	Output	Write Response Valid: This signal indicates that a valid Write response is available: <ul style="list-style-type: none"> • 1 = Write response available • 0 = Write response not available
s_axi_bready	Input	Response Ready: This signal indicates that the master can accept the response information. <ul style="list-style-type: none"> • 1 = Master ready • 0 = Master not ready

Table 2-13: AXI4 Read Channel Interface Signals

Name	Direction	Description
AXI4 Read Address Channel Interface Signals		
s_axi_arid[m:0]	Input	Read Address ID: This signal is the identification tag for the Read address group of signals. Read address ID is optional for Memory Slave configuration and is not supported for Peripheral Slave configuration. Read address ID can be 1 to 16 bits wide.
s_axi_araddr[31:0]	Input	Read Address: The Read address bus gives the initial address of a Read burst transaction. Only the start address of the burst is provided and the control signals that are issued alongside the address detail how the address is calculated for the remaining transfers in the burst.
s_axi_arlen[7:0]	Input	Burst Length: The burst length gives the exact number of transfers in a burst. This information determines the number of data transfers associated with the address.
s_axi_arsize[2:0]	Input	Burst Size: This signal indicates the size of each transfer in the burst. Burst size should always be less than or equal to the width of the Read Data. Burst Size input is not supported for Peripheral Slave configuration.
s_axi_arburst[1:0]	Input	Burst Type: The burst type, coupled with the size information, details how the address for each transfer within the burst is calculated. Burst type for Memory Slave configuration could be either incremental or wrap. Burst type input is not supported for Peripheral Slave configuration, Burst type for Peripheral Slave is always internally set to incremental.

Table 2-13: AXI4 Read Channel Interface Signals (Cont'd)

Name	Direction	Description
s_axi_arvalid	Input	<p>Read Address Valid: This signal indicates, when High, that the Read address and control information is valid and will remain stable until the address acknowledge signal, arready, is high.</p> <ul style="list-style-type: none"> • 1 = address and control information valid • 0 = address and control information not valid
s_axi_arready	Output	<p>Read Address Ready: This signal indicates that the slave is ready to accept an address and associated control signals:</p> <ul style="list-style-type: none"> • 1 = slave ready • 0 = slave not ready
AXI4 Read Data Channel Interface Signals		
s_axi_rid[m:0]	Output	<p>Read ID Tag: This signal is the ID tag of the Read data group of signals. The RID value is generated by the slave and must match the ARID value of the Read transaction to which it is responding. Read ID tag is optional for Memory Slave configuration and is not supported for Peripheral Slave configuration. Read ID can be 1 to 16 bits wide.</p>
s_axi_rdata[m-1:0]	Output	<p>Read Data: For Memory Slave configurations, the Read data bus can be 32, 64, 128, or 256 bits wide. For Peripheral Slave configurations, the Read data bus can be 8, 16, 32, 64, 128, or 256 bits wide.</p>
s_axi_rresp[1:0]	Output	<p>Read Response: This signal indicates the status of the Read transfer. The allowable responses are OKAY, EXOKAY, SLVERR, and DECERR. Read response is always set to OKAY. Read response is generated only when AXI4 ID is enabled for Memory Slave. Read response is not supported for Peripheral Slave configuration.</p>
s_axi_rlast	Output	<p>Read Last: This signal indicates the last transfer in a Read burst.</p>
s_axi_rvalid	Output	<p>Read Valid: This signal indicates that the required Read data is available and the Read transfer can complete:</p> <ul style="list-style-type: none"> • 1 = Read data available • 0 = Read data not available
s_axi_rready	Input	<p>Read Ready: This signal indicates that the master can accept the Read data and response information:</p> <ul style="list-style-type: none"> • 1 = Master ready • 0 = Master not ready

AXI4-Lite Interface Signals

Table 2-14: AXI4-Lite Write Channel Interface Signals

Name	Direction	Description
AXI4-Lite Write Address Channel Interface Signals		
s_axi_awaddr[31:0]	Input	Write Address: The Write address bus gives the address of the first transfer in a Write burst transaction. The associated control signals are used to determine the addresses of the remaining transfers in the burst.
s_axi_awvalid	Input	Write Address Valid: This signal indicates that valid Write address and control information are available: <ul style="list-style-type: none"> • 1 = address and control information available • 0 = address and control information not available. The address and control information remain stable until the address acknowledge signal, awready, goes High
s_axi_awready	Output	Write Address Ready: This signal indicates that the slave is ready to accept an address and associated control signals: <ul style="list-style-type: none"> • 1 = slave ready • 0 = slave not ready
s_axi_awid[m:0]	Input	Write Address ID: This signal is the identification tag for the Write address group of signals Write address ID is optional for Memory Slave configuration and is not supported for Peripheral Slave configuration. Write address ID can be 1 to 16 bits wide.
AXI4-Lite Write Data Channel Interface Signals		
s_axi_wdata[m-1:0]	Input	Write Data: For Memory Slave configurations, the Write data bus can be 32 or 64 bits wide. For Peripheral Slave configurations, the Write data bus can be 8, 16, 32 or 64 bits wide.
s_axi_wstrb[m/8-1:0]	Input	Write Strobes: This signal indicates which byte lanes to update in memory. There is one Write strobe for each eight bits of the Write data bus. Therefore, WSTRB[n] corresponds to WDATA[(8 × n) + 7:(8 × n)].
s_axi_wvalid	Input	Write Valid: This signal indicates that valid Write data and strobes are available: <ul style="list-style-type: none"> 1 = Write data and strobes available 0 = Write data and strobes not available
s_axi_wready	Output	Write Ready: This signal indicates that the slave can accept the Write data: <ul style="list-style-type: none"> • 1 = Slave ready • 0 = Slave not ready
AXI4-Lite Write Response Channel Interface Signals		
s_axi_bvalid	Output	Write Response Valid: This signal indicates that a valid Write response is available: <ul style="list-style-type: none"> • 1 = Write response available • 0 = Write response not available

Table 2-14: AXI4-Lite Write Channel Interface Signals (Cont'd)

Name	Direction	Description
s_axi_bready	Input	Response Ready: This signal indicates that the master can accept the response information. <ul style="list-style-type: none"> • 1 = Master ready • 0 = Master not ready
s_axi_bid[m:0]	Output	Response ID: The identification tag of the Write response. The BID value must match the AWID value of the Write transaction to which the slave is responding. Response ID is optional for Memory Slave configuration and is not supported for Peripheral Slave configuration. Response ID can be 1 to 16 bits wide.
s_axi_bresp[1:0]	Output	Write Response: This signal indicates the status of the Write transaction. The allowable responses are OKAY, EXOKAY, SLVERR, and DECERR. Write response is always set to OKAY. Write response is generated only when AXI4 ID is enabled for Memory Slave. Write response is not supported for Peripheral Slave configuration.

Table 2-15: AXI4-Lite Read Channel Interface Signals

Name	Direction	Description
AXI4-Lite Read Address Channel Interface Signals		
s_axi_araddr[31:0]	Input	Read Address: The Read address bus gives the initial address of a Read burst transaction. Only the start address of the burst is provided and the control signals that are issued alongside the address detail how the address is calculated for the remaining transfers in the burst.
s_axi_arid[m:0]	Input	Read Address ID: This signal is the identification tag for the Read address group of signals. Read address ID is optional for Memory Slave configuration and is not supported for Peripheral Slave configuration. Read address ID can be 1 to 16 bits wide.
s_axi_arvalid	Input	Read Address Valid: This signal indicates, when High, that the Read address and control information is valid and will remain stable until the address acknowledge signal, arready, is High. <ul style="list-style-type: none"> • 1 = Address and control information valid • 0 = Address and control information not valid
s_axi_arready	Output	Read Address Ready: This signal indicates that the slave is ready to accept an address and associated control signals: <ul style="list-style-type: none"> • 1 = Slave ready • 0 = Slave not ready
AXI4-Lite Read Data Channel Interface Signals		
s_axi_rdata[m-1:0]	Output	Read Data: For Memory Slave configurations, the Read data bus can be 32 or 64 bits wide. For Peripheral Slave configurations, the Read data bus can be 8, 16, 32 or 64 bits wide.

Table 2-15: AXI4-Lite Read Channel Interface Signals (Cont'd)

Name	Direction	Description
s_axi_rresp[1:0]	Output	<p>Read Response: This signal indicates the status of the Read transfer. The allowable responses are OKAY, EXOKAY, SLVERR, and DECERR. Read response is always set to OKAY. Read response is generated only when AXI4 ID is enabled for Memory Slave. Read response is not supported for Peripheral Slave configuration.</p>
s_axi_rid[m:0]	Output	<p>Read ID Tag: This signal is the ID tag of the Read data group of signals. The RID value is generated by the slave and must match the ARID value of the Read transaction to which it is responding. Read ID tag is optional for Memory Slave configuration and is not supported for Peripheral Slave configuration. Read ID tag can be 1 to 16 bits wide.</p>
s_axi_rvalid	Output	<p>Read Valid: This signal indicates that the required Read data is available and the Read transfer can complete:</p> <ul style="list-style-type: none"> • 1 = Read data available • 0 = Read data not available
s_axi_rready	Input	<p>Read Ready: This signal indicates that the master can accept the Read data and response information:</p> <ul style="list-style-type: none"> • 1 = Master ready • 0 = Master not ready

Designing with the Core

This chapter describes the steps required to turn a Block memory Generator core into a fully functioning design integrated with the user application logic. It is important to note that depending on the configuration of the BMG core, only a subset of the implementation details provided are applicable. The guidelines in this chapter provide details about creating the most successful implementation of the core.

General Design Guidelines

The Block Memory Generator is used to build custom memory modules from block RAM primitives in Xilinx FPGAs. The core implements an optimal memory by arranging block RAM primitives based on user selections, automating the process of primitive instantiation and concatenation. Using the Vivado Design Suite IP Catalog, users can configure the core and rapidly generate a highly optimized custom memory solution.

Memory Type

The Block Memory Generator creates five memory types: Single-port RAM, Simple Dual-port RAM, True Dual-port RAM, Single-port ROM, and Dual-port ROM. [Figure 3-1](#) through [Figure 3-5](#) illustrate the signals available for each type. Optional pins are displayed in italics.

For each configuration, optimizations are made within the core to minimize the total resources used. For example, a Simple Dual-port RAM with symmetric ports can utilize the special Simple Dual-port RAM primitive in 7 series devices, which can save as much as fifty percent of the block RAM resources for memories 512 words deep or fewer. The Single-port ROM allows Read access to the memory space through a single port, as illustrated in [Figure 3-1](#).

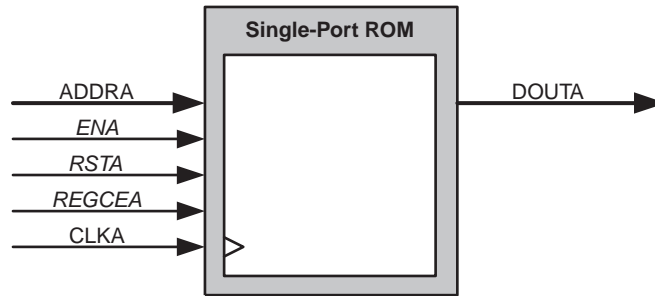

Figure 3-1: Single-port ROM

The Dual-port ROM allows Read access to the memory space through two ports, as shown in Figure 3-2.

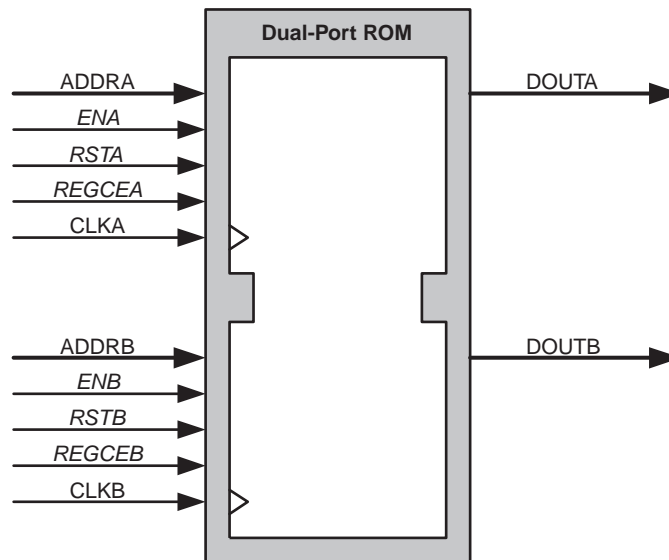

Figure 3-2: Dual-port ROM

The Single-port RAM allows Read and Write access to the memory through a single port, as shown in Figure 3-3.

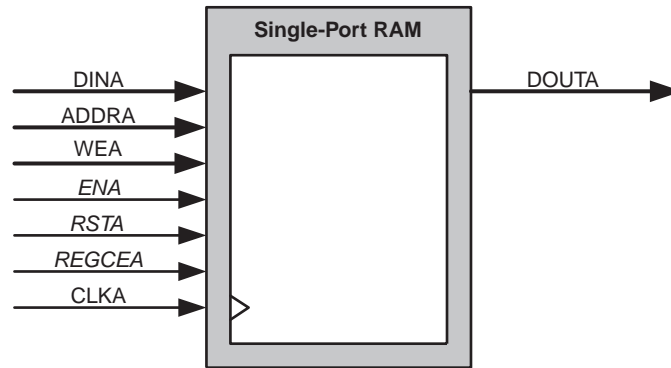

Figure 3-3: Single-port RAM

The Simple Dual-port RAM provides two ports, A and B, as illustrated in Figure 3-4. Write access to the memory is allowed via port A, and Read access is allowed via port B.



IMPORTANT: For 7 series family architectures, though the diagram below shows port A as write port and port B as Read Port, in the FPGA the BRAM primitives do Read access via port A and Write access via port B.

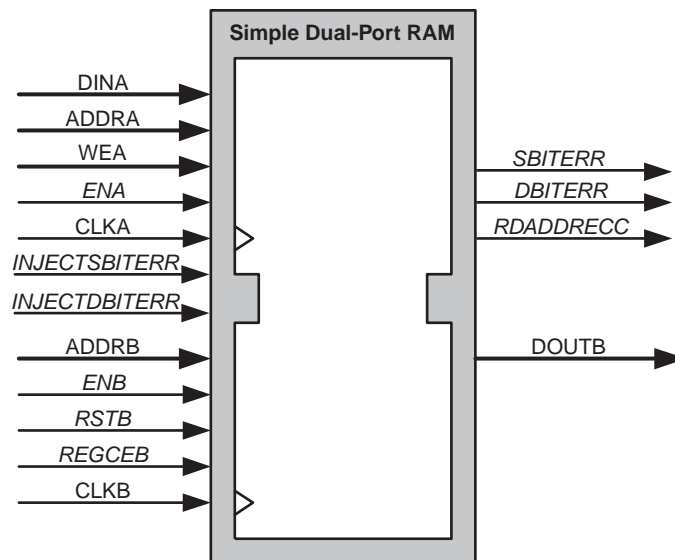

Figure 3-4: Simple Dual-port RAM

The True Dual-port RAM provides two ports, A and B, as illustrated in Figure 3-5. Read and Write accesses to the memory are allowed on either port.

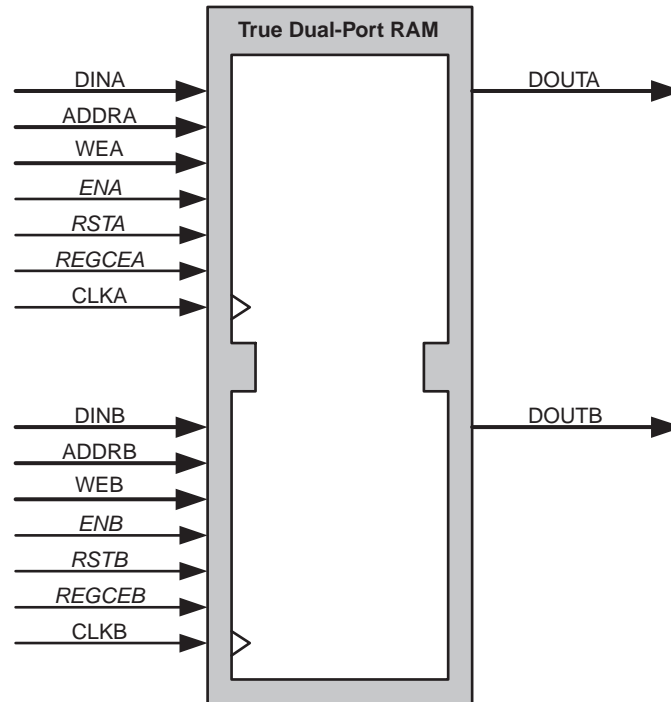

Figure 3-5: True Dual-port RAM

Selectable Memory Algorithm

The Block Memory Generator core arranges block RAM primitives according to one of three algorithms: the minimum area algorithm, the low power algorithm and the fixed primitive algorithm.

Minimum Area Algorithm

The minimum area algorithm provides a highly optimized solution, resulting in a minimum number of block RAM primitives used, while reducing output multiplexing. [Figure 3-6](#) shows two examples of memories built using the minimum area algorithm.

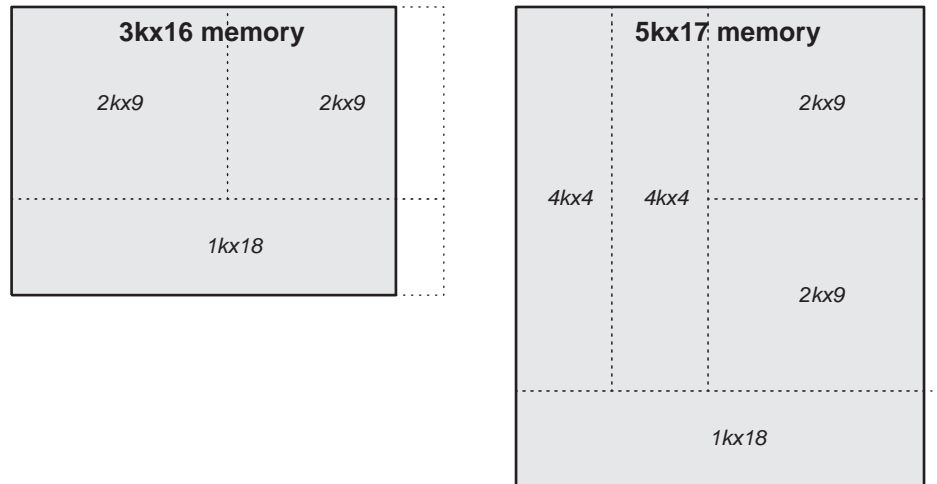

Figure 3-6: Examples of the Minimum Area Algorithm

In the first example, a 3kx16 memory is implemented using three block RAMs. While it may have been possible to concatenate three 1kx18 block RAMs in depth, this would require more output multiplexing. The minimum area algorithm maximizes performance in this way while maintaining minimum block RAM usage.

In the second example, a 5kx17 memory, further demonstrates how the algorithm can pack block RAMs efficiently to use the fewest resources while maximizing performance by reducing output multiplexing.

Low Power Algorithm

The low power algorithm provides a solution that minimizes the number of primitives enabled during a Read or Write operation. This algorithm is not optimized for area and may use more block RAMs and multiplexers than the minimum area algorithm. Figure 3-7 shows two examples of memories built using the low power algorithm.

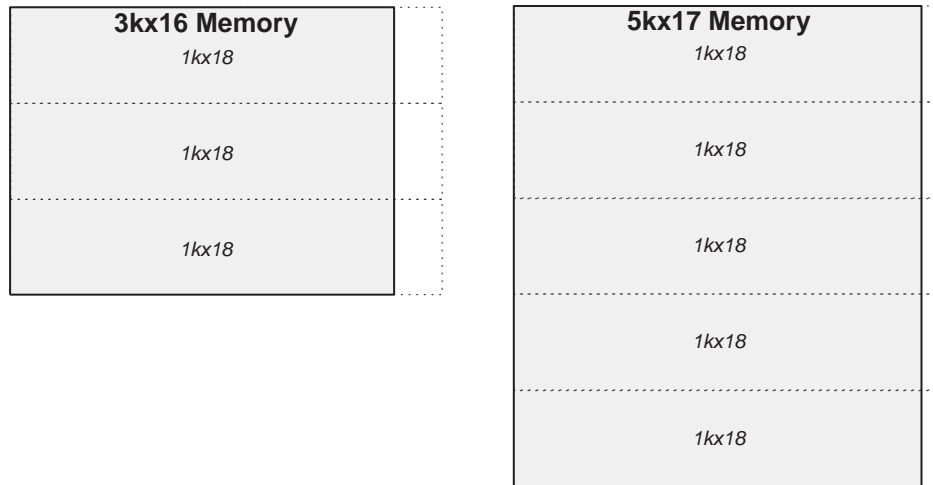

Figure 3-7: Examples of the Low Power Algorithm

Fixed Primitive Algorithm

The fixed primitive algorithm allows the user to select a single block RAM primitive type. The core will build the memory by concatenating this single primitive type in width and depth. It is useful in systems that require a fixed primitive type. Figure 3-8 depicts two 3kx16 memories, one built using the 2kx9 primitive type, the other built using the 4kx4 primitive type.

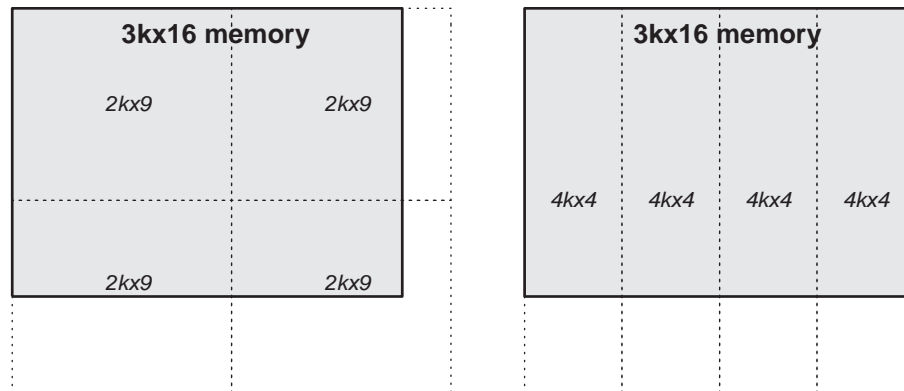

Figure 3-8: Examples of the Fixed Primitive Algorithm

Note that both implementations use four block RAMs, and that some of the resources utilized extend beyond the usable memory space. It is up to the user to decide which primitive type is best for their application.

The fixed primitive algorithm provides a choice of 16kx1, 8kx2, 4kx4, 2kx9, 1kx18, and 512x36 primitives. The primitive type selected is used to guide the construction of the total user memory space. Whenever possible, optimizations are made automatically that use deeper embedded memory structures to enhance performance. Table 3-1 shows the

primitives used to construct a memory given the specified architecture and primitive selection.

Table 3-1: Memory Primitives Used Based on Architecture (Supported in Native BMG)

Architecture	Primitive Selection	Primitives Used
Zynq-7000	16kx1	64x1, 32kx1, 16kx1
	8kx2	16kx2, 8kx2
	4kx4	4kx4, 8kx4
	2kx9	2kx9, 4kx9
	1kx18	1kx18, 2kx18
	512x36	512x36 (SP RAM/ROM and SDP configurations only), 1kx36
Artix-7	16kx1	64x1, 32kx1, 16kx1
	8kx2	16kx2, 8kx2
	4kx4	4kx4, 8kx4
	2kx9	2kx9, 4kx9
	1kx18	1kx18, 2kx18
	512x36	512x36 (SP RAM/ROM and SDP configurations only), 1kx36
Kintex-7	16kx1	64x1, 32kx1, 16kx1
	8kx2	16kx2, 8kx2
	4kx4	4kx4, 8kx4
	2kx9	2kx9, 4kx9
	1kx18	1kx18, 2kx18
	512x36	512x36 (SP RAM/ROM and SDP configurations only), 1kx36
Virtex-7	16kx1	64x1, 32kx1, 16kx1
	8kx2	16kx2, 8kx2
	4kx4	4kx4, 8kx4
	2kx9	2kx9, 4kx9
	1kx18	1kx18, 2kx18
	512x36	512x36 (SP RAM/ROM and SDP configurations only), 1kx36

Notes:

1. Refer to Additional memory collision restrictions in [Collision Behavior, page 54](#).

When using data-width aspect ratios, the primitive type dimensions are chosen with respect to the A port Write width. Note that primitive selection may limit port aspect ratios as described in [Aspect Ratio Limitations, page 52](#). When using the byte Write feature, only the 2kx9, 1kx18, and 512kx36 primitive choices are available.

Selectable Width and Depth

The Block Memory Generator generates memories with widths from 1 to 4608 bits, and with depths of two or more words. The memory is built by concatenating block RAM primitives, and total memory size is limited only by the number of block RAMs on the target device.

Write operations to out-of-range addresses are guaranteed not to corrupt data in the memory, while Read operations to out-of-range addresses will return invalid data. Note that the set/reset function should not be asserted while accessing an out-of-range address as this also results in invalid data on the output in the present or following clock cycles depending upon the output register stages of the core.

Operating Mode

The operating mode for each port determines the relationship between the Write and Read interfaces for that port. Port A and port B can be configured independently with any one of three Write modes: Write First Mode, Read First Mode, or No Change Mode. These operating modes are described in the sections that follow.

The operating modes have an effect on the relationship between the A and B ports when the A and B port addresses have a collision. For detailed information about collision behavior, see [Collision Behavior, page 54](#). For more information about operating modes, see the block RAM section of the user guide specific to the device family.

- Write First Mode:** In WRITE_FIRST mode, the input data is simultaneously written into memory and driven on the data output, as shown in [Figure 3-9](#). This transparent mode offers the flexibility of using the data output bus during a Write operation on the same port.

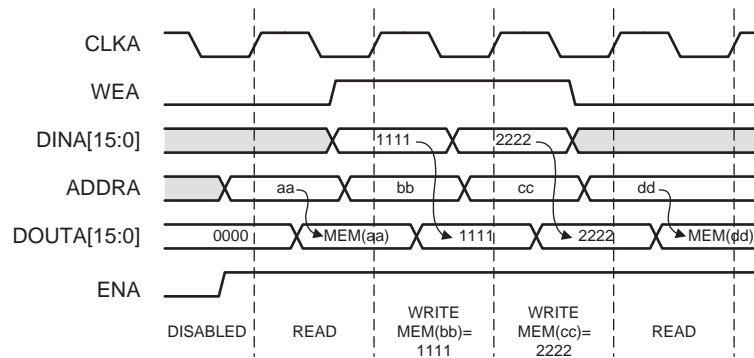

Figure 3-9: Write First Mode Example

Note: The WRITE_FIRST operation is affected by the optional byte-Write feature. It is also affected by the optional Read-to-Write aspect ratio feature. For detailed information, see [Write First Mode Considerations, page 53](#).

- Read First Mode:** In READ_FIRST mode, data previously stored at the Write address appears on the data output, while the input data is being stored in memory. This Read-before-Write behavior is illustrated in [Figure 3-10](#).

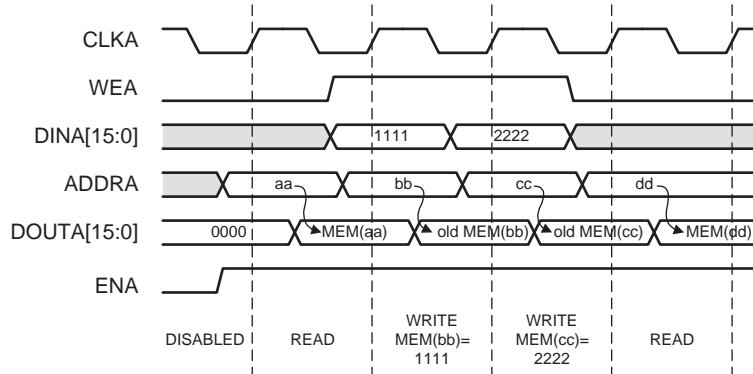

Figure 3-10: Read First Mode Example

- No Change Mode:** In NO_CHANGE mode, the output latches remain unchanged during a Write operation. As shown in Figure 3-11, the data output is still the previous Read data and is unaffected by a Write operation on the same port.

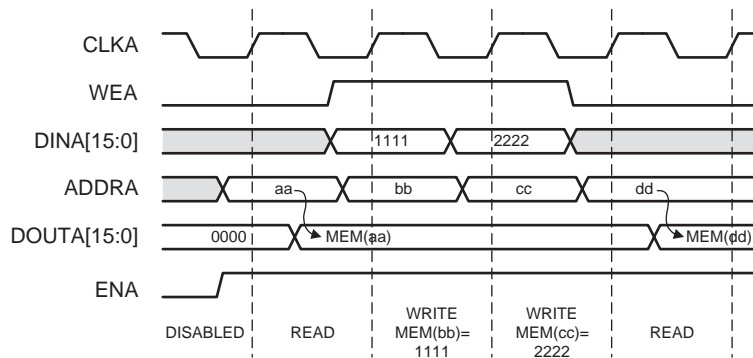

Figure 3-11: No Change Mode Example

Data Width Aspect Ratios

The Block Memory Generator supports data width aspect ratios. This allows the port A data width to be different than the port B data width, as described in Port Aspect Ratios in the following section. All four data buses (*dina*, *douta*, *dinb*, and *doutb*) can have different widths, as described in [Read-to-Write Aspect Ratios, page 51](#).

The limitations of the data width aspect ratio feature (some of which are imposed by other optional features) are described in [Aspect Ratio Limitations, page 52](#). The Vivado IP Catalog GUI ensures only valid aspect ratios are selected.

Port Aspect Ratios

The Block Memory Generator supports port aspect ratios of 1:32, 1:16, 1:8, 1:4, 1:2, 1:1, 2:1, 4:1, 8:1, 16:1, and 32:1. The port A data width can be up to 32 times larger than the port B data width, or vice versa. The smaller data words are arranged in little-endian format, as illustrated in [Figure 3-12](#).

Port Aspect Ratio Example

Consider a True Dual-port RAM of 32x2048, which is the A port width and depth. From the perspective of an 8-bit B port, the depth would be 8192. The `addra` bus is 11 bits, while the `addrb` bus is 13 bits. The data is stored little-endian, as shown in Figure 3-12. Note that A_n is the data word at address n , with respect to the A port. B_n is the data word at address n with respect to the B port. A_0 is comprised of $B_3, B_2, B_1,$ and B_0 .

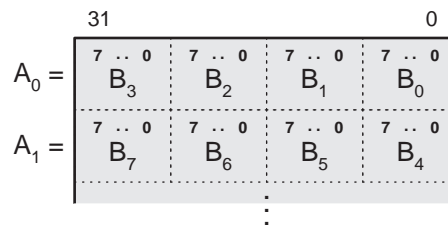

Figure 3-12: Port Aspect Ratio Example Memory Map

Read-to-Write Aspect Ratios

When implementing RAMs, the Block Memory Generator allows Read and Write aspect ratios on either port. On each port A and port B, the Read to Write data width ratio of that port can be 1:32, 1:16, 1:8, 1:4, 1:2, 1:1, 2:1, 4:1, 8:1, 16:1, or 32:1.

Because the Read and Write interfaces of each port can differ, it is possible for all four data buses (`dina`, `douta`, `dinb`, and `doutb`) of True Dual-port RAMs to have a different width. For Single-port RAMs, `dina` and `douta` widths can be independent. The maximum ratio between any two data buses is 32:1. The widest data bus can be no larger than 4608 bits.

If the Read and Write data widths on a port are different, the memory depth is different with respect to Read and Write accesses. For example, if the Read interface of port A is twice as wide as the Write interface, then it is also half as deep. The ratio of the widths is *always* the inverse of the ratio of the depths. Because a single address bus is used for both the Write and Read interface of a port, the address bus must be large enough to address the deeper of the two depths. For the shallower interface, the least significant bits of the address bus are ignored. The data words are arranged in little-endian format, as illustrated in Figure 3-13.

Read-to-Write Aspect Ratio Example

Consider a True Dual-port RAM of 64x512, which is the port A Write width and depth. Table 3-2 defines the four data-port widths and their respective depths for this example.

Table 3-2: Read-to-Write Aspect Ratio Example Ports

Interface	Data Width	Memory Depth
Port A Write	64	512
Port A Read	16	2048

Table 3-2: Read-to-Write Aspect Ratio Example Ports

Interface	Data Width	Memory Depth
Port B Write	256	128
Port B Read	32	1024

The `addr_a` width is determined by the larger of the A port depths (2048). For this reason, `addr_a` is 11 bits wide. On port A, Read operations utilize the entire `addr_a` bus, while Write operations ignore the least significant 2 bits.

In the same way, the `addr_b` width is determined by the larger of the B port depths (1024). For this reason, `addr_b` is 10 bits wide. On port B, Read operations utilize the entire `addr_b` bus, while Write operations ignore the least significant 3 bits.

The memory map in Figure 3-13 shows how port B Write words are related to port A Write words, in a little-endian arrangement. Note that AW_n is the Write data word at address n with respect to port A, while BW_n is the Write data word at address n with respect to port B.

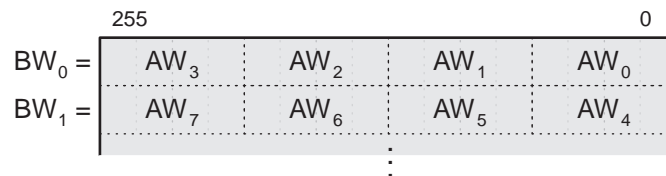

Figure 3-13: Read-to-Write Aspect Ratio Example Memory Map

BW_0 is made up of AW_3 , AW_2 , AW_1 , and AW_0 . In the same way, BR_0 is made up of AR_1 and AR_0 , and AW_0 is made up of BR_1 and BR_0 . In the example above, the largest data width ratio is port B Write words (256 bits) to port A Read words (16 bits); this ratio is 16:1.

Aspect Ratio Limitations

In general, no port data width can be wider than 4096 bits, and no two data widths can have a ratio greater than 32:1. However, the following optional features further limit data width aspect ratios:

- **Byte-writes:** When using byte-writes, no two data widths can have a ratio greater than 4:1.
- **Fixed primitive algorithm:** When using the fixed primitive algorithm with an N-bit wide primitive, aspect ratios are limited to 32:N and 1:N from the port A Write width. For example, using the 4kx4 primitive type, the other ports may be no more than 8 times (32:4) larger than port A Write width and no less than 4 times (1:4) smaller.

Byte-Writes

The Block Memory Generator provides byte-Write support. Byte-writes are available using either 8-bit or 9-bit byte sizes. When using an 8-bit byte size, no parity bits are used and the

memory width is restricted to multiples of 8 bits. When using a 9-bit byte size, each byte includes a parity bit, and the memory width is restricted to multiples of 9 bits.

When byte-writes are enabled, the $we[a|b]$ (wea or web) bus is N bits wide, where N is the number of bytes in $din[a|b]$. The most significant bit in the Write enable bus corresponds to the most significant byte in the input word. Bytes will be stored in memory only if the corresponding bit in the Write enable bus is asserted during the Write operation.

When 8-bit bytes are selected, the din and $dout$ data buses are constructed from 8-bit bytes, with no parity. When 9-bit bytes are selected, the din and $dout$ data buses are constructed from 9-bit bytes, with the 9th bit of each byte in the data word serving as a parity bit for that byte.

The byte-Write feature may be used in conjunction with the data width aspect ratios, which may limit the choice of data widths as described in [Data Width Aspect Ratios, page 50](#). However, it may not be used with the NO_CHANGE operating mode. This is because if a memory configuration uses multiple primitives in width, and only one primitive is being written to (using partial byte writes), then the NO_CHANGE mode only applies to that single primitive. The NO_CHANGE mode does not apply to the other primitives that are not being written to, so these primitives can still be read. The byte-Write feature also affects the operation of WRITE_FIRST mode, as described in [Write First Mode Considerations, page 53](#).

Byte-Write Example

Consider a Single-port RAM with a data width of 24 bits, or 3 bytes with byte size of 8 bits. The Write enable bus, wea , consists of 3 bits. [Figure 3-14](#) illustrates the use of byte-writes, and shows the contents of the RAM at address 0. Assume all memory locations are initialized to 0.

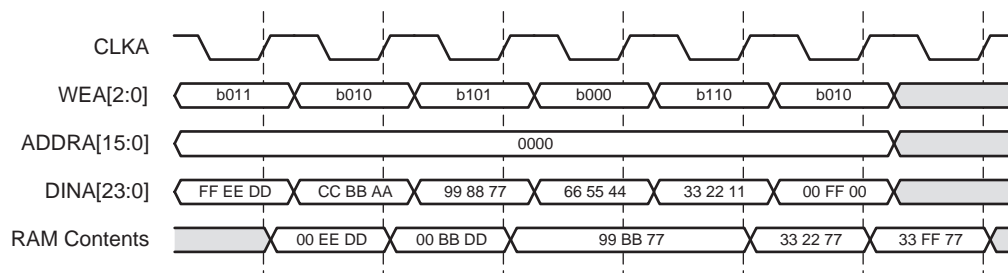

Figure 3-14: Byte-Write Example

Write First Mode Considerations

When performing a Write operation in WRITE_FIRST mode, the concurrent Read operation shows the newly written data on the output of the core. However, when using the byte-Write or the Read-to-Write aspect ratio feature, the output of the memory cannot be guaranteed.

Collision Behavior

The Block Memory Generator core supports Dual-port RAM implementations. Each port is equivalent and independent, yet they access the same memory space. In such an arrangement, is it possible to have data collisions. The ramifications of this behavior are described for both asynchronous and synchronous clocks below.

Collisions and Asynchronous Clocks: General Guidelines

Using asynchronous clocks, when one port writes data to a memory location, the other port must not Read or Write that location for a specified amount of time. This clock-to-clock setup time is defined in the device data sheet, along with other block RAM switching characteristics.

Collisions and Synchronous Clocks: General Guidelines

Synchronous clocks cause a number of special case collision scenarios, described below.

- **Synchronous Write-Write Collisions:** A Write-Write collision occurs if both ports attempt to Write to the same location in memory. The resulting contents of the memory location are unknown. Note that Write-Write collisions affect memory content, as opposed to Write-Read collisions which only affect data output.
- **Using Byte-Writes:** When using byte-writes, memory contents are not corrupted when separate bytes are written in the same data word. RAM contents are corrupted only when both ports attempt to Write the same byte. [Figure 3-15](#) illustrates this case. Assume $addr_a = addr_b = 0$.

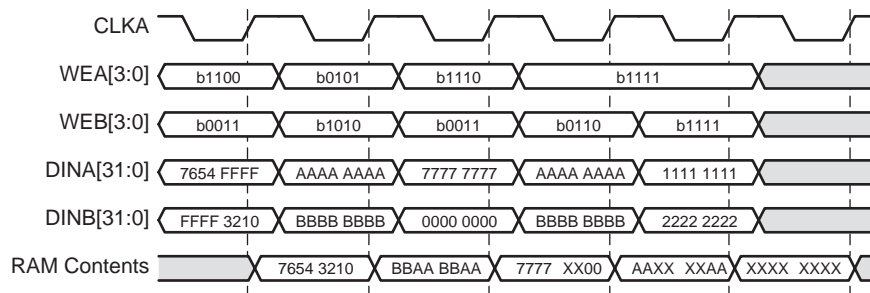

Figure 3-15: Write-Write Collision Example

- **Synchronous Write-Read Collisions:** A synchronous Write-Read collision may occur if a port attempts to Write a memory location and the other port reads the same location. While memory contents are not corrupted in Write-Read collisions, the validity of the output data depends on the Write port operating mode.
 - If the Write port is in READ_FIRST mode, the other port can reliably read the old memory contents.
 - If the Write port is in WRITE_FIRST or NO_CHANGE mode, data on the output of the Read port is invalid.

- In the case of byte-writes, only bytes which are updated will be invalid on the Read port output.

Figure 3-16 illustrates Write-Read collisions and the effects of byte-writes. `doutb` is shown for when port A is in WRITE_FIRST mode and READ_FIRST mode. Assume `addr_a = addr_b = 0`, port B is always reading, and all memory locations are initialized to 0. The RAM contents are never corrupted in Write-Read collisions.

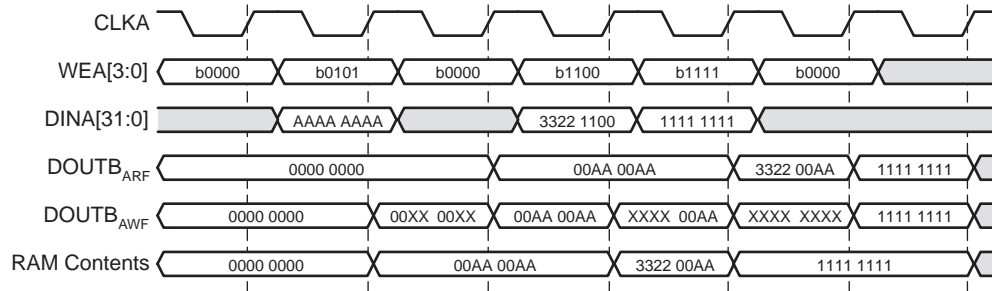

Figure 3-16: Write-Read Collision Example

Collisions and Simple Dual-port RAM

For Simple Dual-port RAM, the operating modes are not selectable, but are automatically set to either READ_FIRST or WRITE_FIRST depending on the target device family and clocking configuration (synchronous or asynchronous). The Simple Dual-port RAM is like a true dual-port RAM where only the Write interface of the A port and the Read interface of B port are connected. The operating modes define the Write-to-Read relationship of the A or B ports, and only impact the relationship between A and B ports during an address collision.

For Synchronous Clocking and during a collision, the Write mode of port A can be configured so that a Read operation on port B either produces data (acting like READ_FIRST), or produces undefined data (Xs). For this reason, the core is hard-coded to produce READ_FIRST-like behavior when configured as a Simple Dual-port RAM. For detailed information about this behavior, see [Collision Behavior, page 54](#).

Exceptions: The operating mode (READ_FIRST or WRITE_FIRST respectively) is determined by whether the clocking mode selection is Synchronous (Common Clock) or Asynchronous.

Additional Memory Collision Restrictions: Address Space Overlap

The 7 series FPGA block RAM memories have additional collision restrictions in the following configurations:

- When configured as True Dual Port (TDP)
- When CLKA (port A) and CLKB (port B) are Asynchronous
- In applications that perform a simultaneous Read and Write

- When either port A, port B, or both ports are configured with Write Mode configured as READ_FIRST

When using TDP Memory with Write Mode = READ_FIRST (TDP-RF mode) in conjunction with asynchronous clocking, see the "Conflict Avoidance" section of the *7 Series FPGAs Memory Resources User Guide* (UG473).

Optional Output Registers

The Block Memory Generator allows optional output registers, which may improve the performance of the core. The user may choose to include register stages at two places: at the output of the block RAM primitives and at the output of the core.

Registers at the output of the block RAM primitives reduce the impact of the clock-to-out delay of the primitives. Registers at the output of the core isolate the delay through the output multiplexers, improving the clock-to-out delay of the Block Memory Generator core. Each of the two optional register stages can be chosen for port A and port B separately. Note that each optional register stage used adds an additional clock cycle of latency to the Read operation.

The Register Port [A|B] Output of Memory Primitives option may be implemented using the embedded block RAM registers, requiring no further FPGA resources. All other register stages are implemented in FPGA fabric. [Figure 3-17](#) shows an example of memory that has been configured using both output register stages for one of the ports.

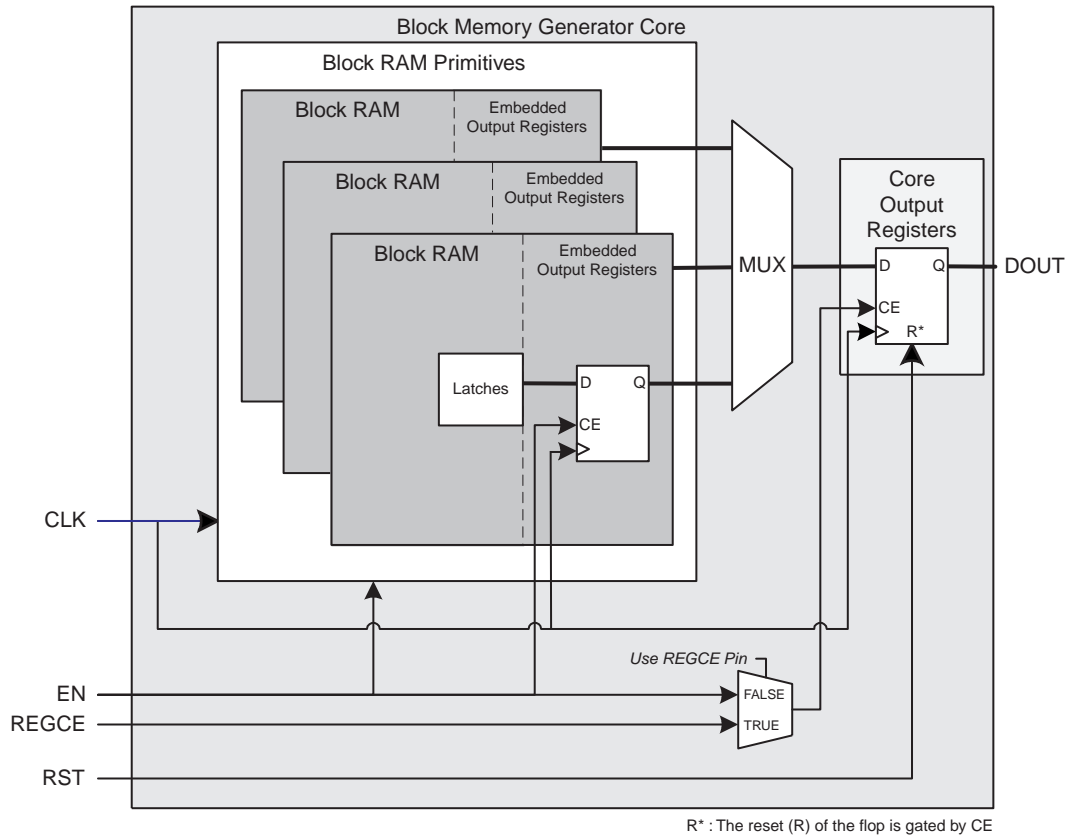

Figure 3-17: Block Memory with Register Port [A|B] Output of Memory Primitives and Register Port [A|B] Output of Memory Core Options Enabled

For a complete description of the supported output options, see [Output Register Configurations in Appendix D](#).

Optional Pipeline Stages

The Block Memory Generator core allows optional pipeline stages within the MUX, which may improve core performance. Users can add up to three pipeline stages within the MUX, excluding the registers at the output of the core. This optional pipeline stages option is available only when the registers at the output of the memory core are enabled and when the constructed memory has more than one primitive in depth, so that a MUX is needed on the output.

The pipeline stages are common for port A and port B and can be a value of 1, 2, or 3 if the Register Output of Memory Core option is selected in the GUI for both port A and port B. Note that each pipeline stage adds an additional clock cycle of latency to the Read operation.

If the configuration has BuiltIn_ECC (ECC), the SBITERR and DBITERR outputs are delayed to align with DOUT. Note that adding pipeline stages within the MUX improves performance only if the critical path in the design is the data through the MUX. The MUX size displayed

in the GUI can be used to determine the number of pipeline stages to use within the MUX. Figure 3-18 shows a memory configuration with an 8:1 MUX and two pipeline stages within the MUX. In the figure, the 8:1 MUX is pipelined internally with two register stages.

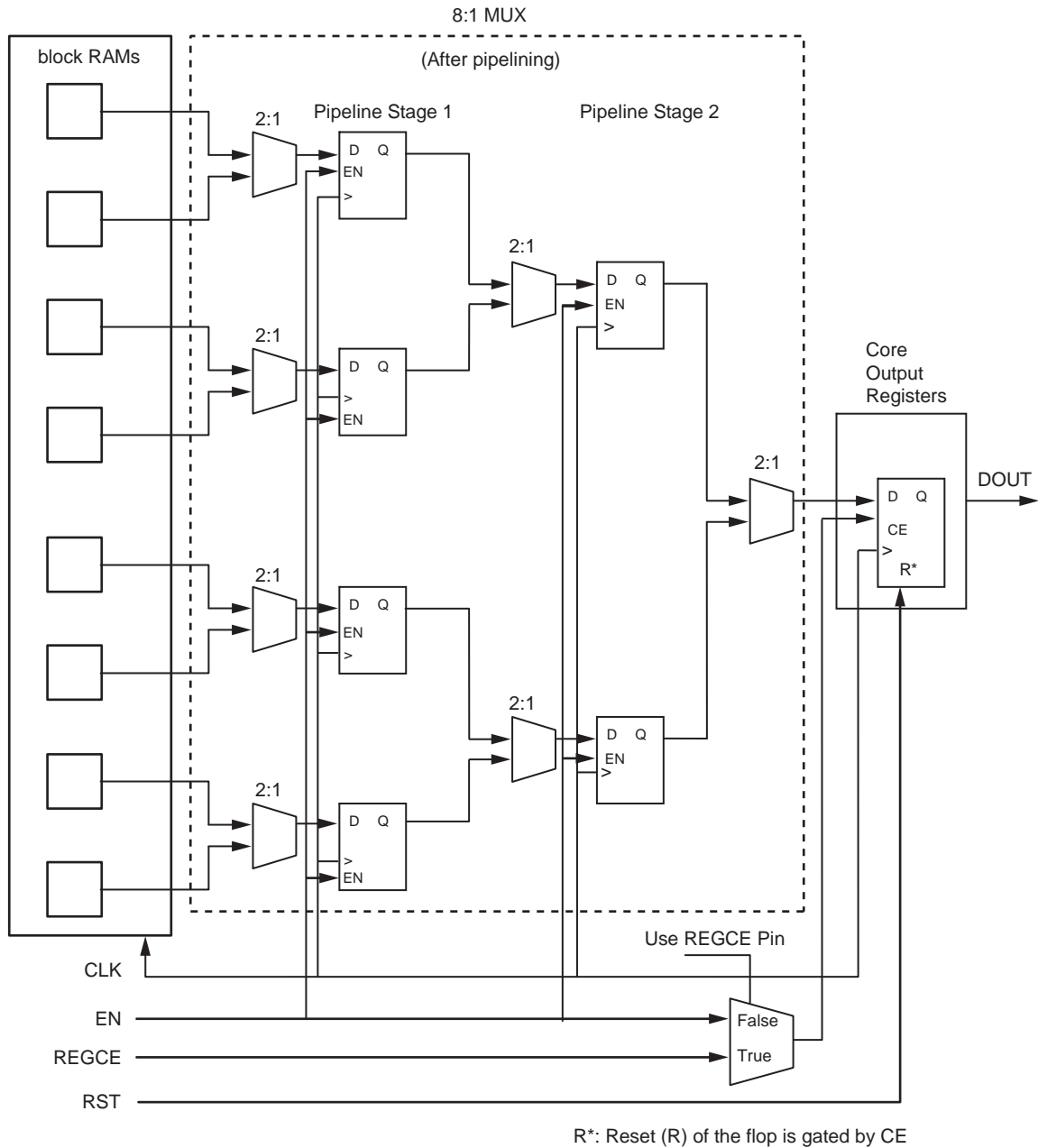

Figure 3-18: Memory Configuration with 8:1 MUX and Two Pipeline Stages within the MUX

Note: The Enable signal must be connected to each pipeline stage in the core and must be asserted for N clock cycles, where N is the number of pipeline stages.

Optional Register Clock Enable Pins

The optional output registers are enabled by the `en` signal by default. However, when the **Use REGCEA/REGCEB Pin** option is selected, the output register stage of the corresponding port is controlled by the `regcea/regceb` pins; the data output from the core can be controlled independent of the flow of data through the rest of the core. When using the `regce` pin, the last output register operates independent of the `en` signal.

Optional Set/Reset Pins

The set/reset pins (`rsta` and `rstb`) control the reset operation of the last register in the output stage. For memories with no output registers, the reset pins control the memory output latches.

When `rst` and `regce` are asserted on a given port, the data on the output of that port is driven to the reset value defined in the Vivado IP Catalog GUI. (The reset occurs on `rst` and `en` when the Use REGCE Pin option is not selected.) The set/reset behavior differs when the reset behavior option is selected. See [Special Reset Behavior](#), page 62 for more information.

Memory Output Flow Control

The combination of the enable (`en`), reset (`rst`), and register enable (`REGCE`) pins allow a wide range of data flows in the output stage. [Figure 3-19](#) and [Figure 3-20](#) are examples on how this can be accomplished. Keep in mind that the `rst` and `REGCE` pins apply only to the last register stage.

[Figure 3-19](#) depicts how `rst` can be used to control the data output to allow only intended data through. Assume that both output registers are used for port A, the port A reset value is `0xFFFF`, and that `en` and `regce` are always asserted. The data on the block RAM memory latch is labeled `LATCH`, while the output of the block RAM embedded register is labeled `REG1`. The output of the last register is the output of the core, `dout`.

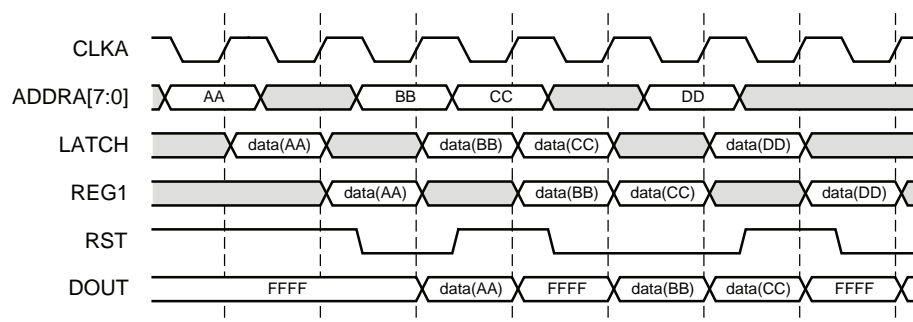

Figure 3-19: Flow Control Using `rst`

[Figure 3-20](#) depicts how `REGCE` can be used to latch the data output to allow only intended data through. Assume that only the memory primitive registers are used for port A, and that `en` is always asserted and `rst` is always deasserted. The data on the block RAM memory

latch is labeled latch, while the output of the last register, the block RAM embedded register, is the core output, dout.

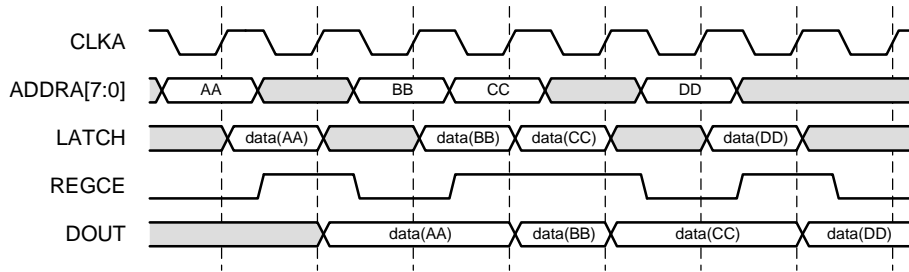

Figure 3-20: Flow Control Using REGCE

Read Data and Read Enable Latency

Figure 3-21 shows the read data (LATCH) and read enable (en) latency when there are no output registers used is shown below. The LATCH signal is the data at the output of the primitive.

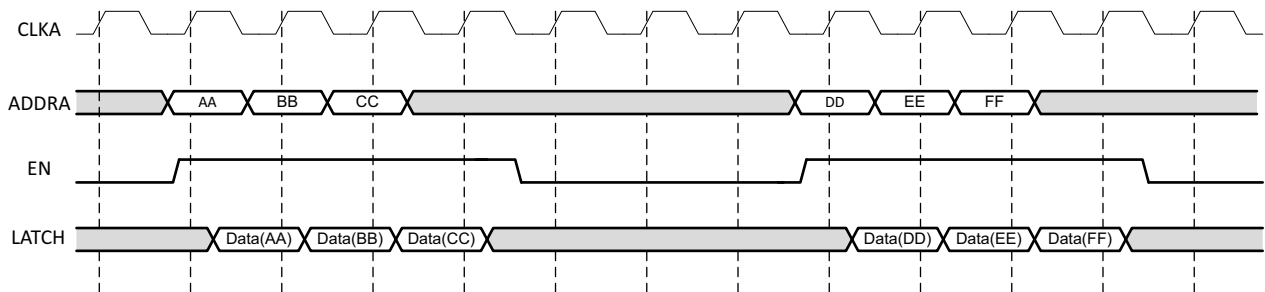

Figure 3-21: Read Data and Read Enable Latency with no Output Registers

Figure 3-22 shows the read data (REG1) and read enable (en) latency when the primitive output register is used. REG1 is the data at the output of the primitive output register.

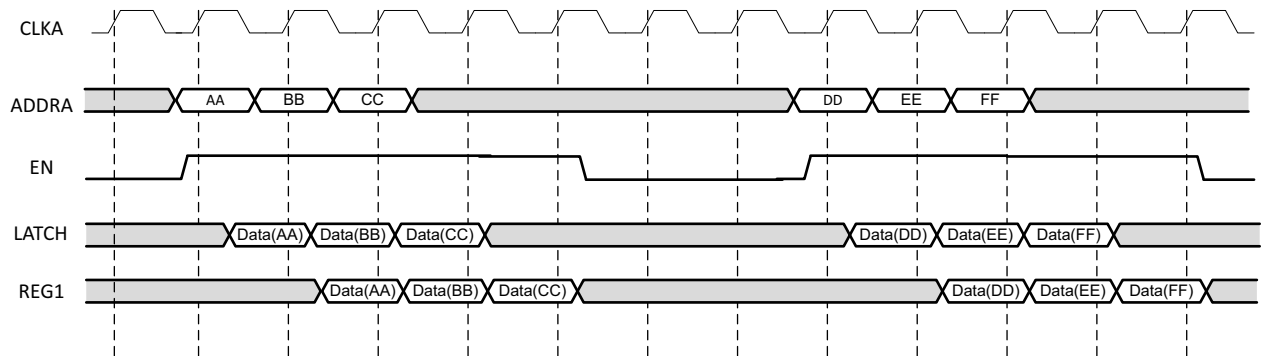

Figure 3-22: Read Data and Read Enable Latency with Primitive Output Registers

Figure 3-23 shows the read data (REG2, REG3) and read enable (en) latency when two pipeline stages are used along with the primitive output register. REG2 is the data at the output of the pipeline stage 1, and REG3 is the data at the output of the pipeline stage 2.

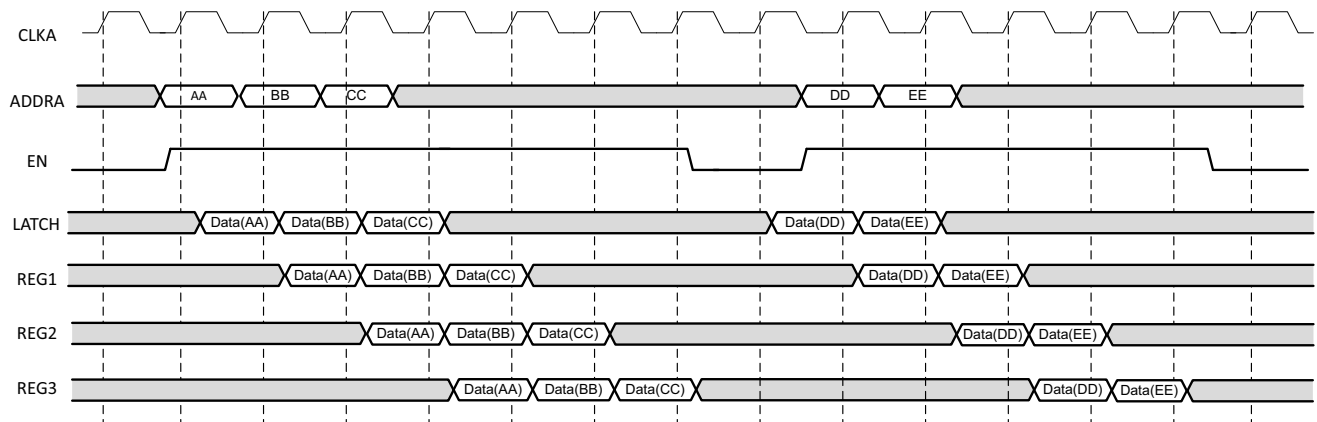

Figure 3-23: Read Data and Read Enable Latency with Two Pipeline Stages Used

Figure 3-24 shows the read data (dout) and read enable (en) latency when the core output registers are used along with the primitive output register and two pipeline stages. dout is the data at the output of the core output register.

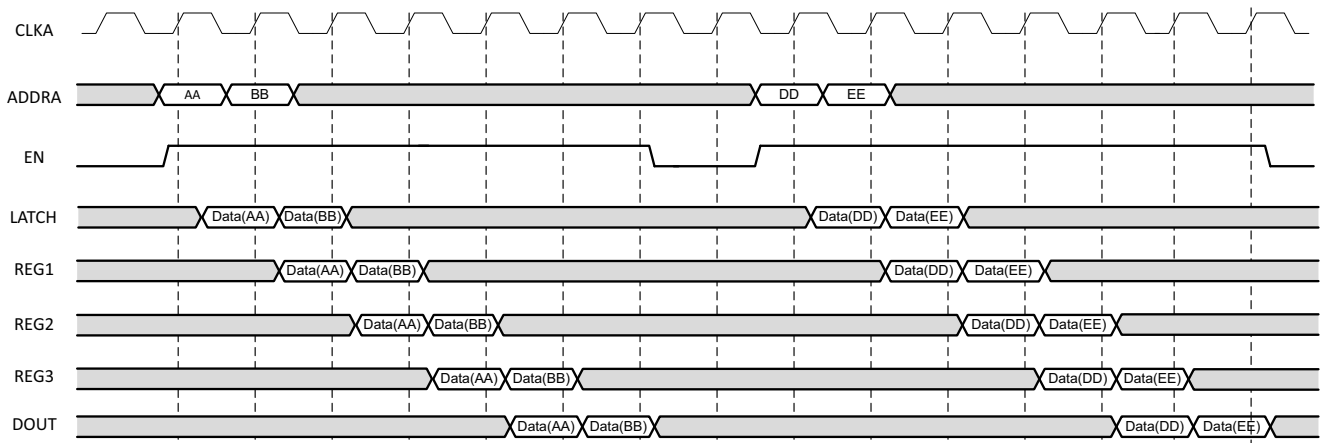

Figure 3-24: Read Data and Read Enable Latency with Core and Primitive Output Registers

Reset Priority

The Block Memory Generator core provides the option to choose the reset priority of the output stages of the Block Memory. Reset priority can be set only for the output registers and not for the memory latch. When CE is the selected priority, then CE (regcea or regceb) has a priority over reset (rsta or rstb). When SR is the selected reset priority, then reset has a priority over CE.

Figure 3-25 illustrates the reset behavior when the Reset Priority option is set to CE. Here, the first reset operation occurs successfully because en is High, but the second reset operation does not cause any change in output because en is Low.

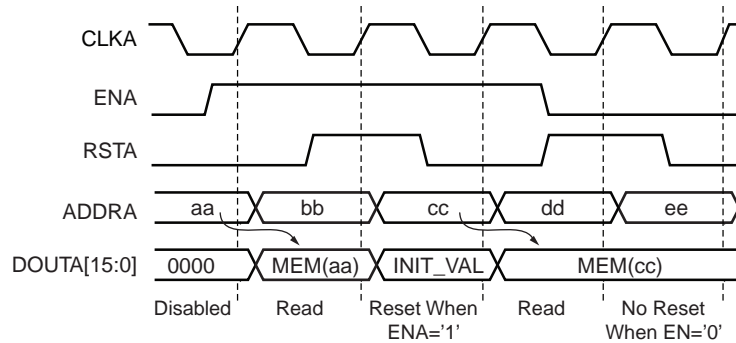

Figure 3-25: Reset Behavior When Reset Priority is Set to CE

Figure 3-26 illustrates the reset behavior when the Reset Priority option is set to SR. Here, reset is not dependent on enable and both reset operations occur successfully.

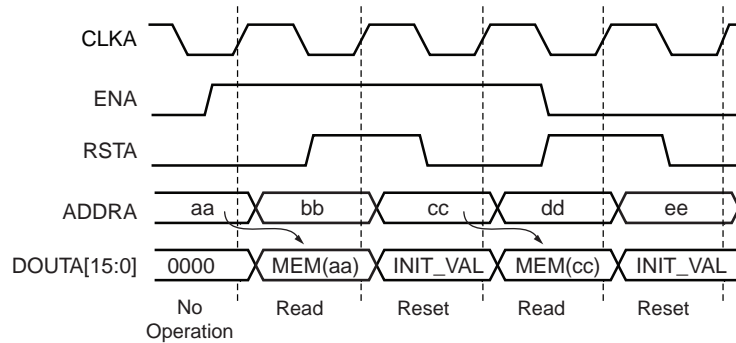

Figure 3-26: Reset Behavior When Reset Priority is Set to SR

Special Reset Behavior

The Block Memory Generator provides the option to reset both the memory latch and the embedded primitive output register. This Reset Behavior option is available to users when they choose to have a primitive output register, but no core output register. When a user chooses the option to Reset the Memory Latch besides the primitive output register, then the reset value is asserted at the output for two clock cycles. However, when the user does not choose the option to Reset the Memory Latch in the presence of a primitive output register, the reset value is asserted at the output for only one clock cycle, since only the primitive output register is reset.

Note that the duration of reset assertion specified here is the minimum duration when the latch and register are always enabled, and the rst input is held high for only one clock cycle. If the enable signals are de-asserted or the rst input is held high for more than one clock cycle, the reset value may be asserted at the output for a longer duration.

The latch and the embedded output register can be reset independently using two separate inputs (*rstreg* and *rstram*) that are connected to the primitive. So, if the user does not choose to reset the memory latch, only the embedded output register is reset.

Figure 3-27 and Figure 3-28 illustrate the difference between the standard reset behavior similar to previous architectures obtained when the memory latch is not reset, and the special reset behavior in the new architectures, obtained when the memory latch is reset. Note that there is an extra clock cycle of latency in the data output because of the presence of the primitive output register.

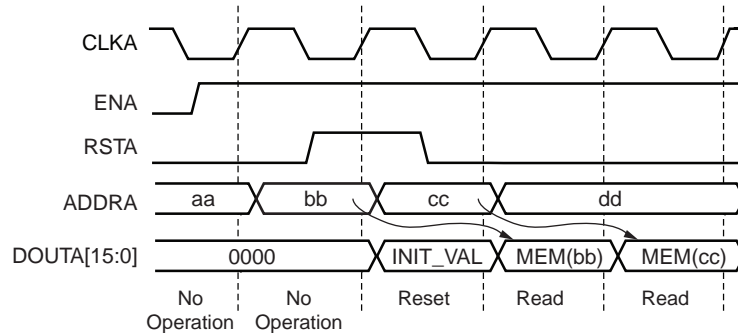

Figure 3-27: Standard Reset Behavior Similar to Previous Architectures

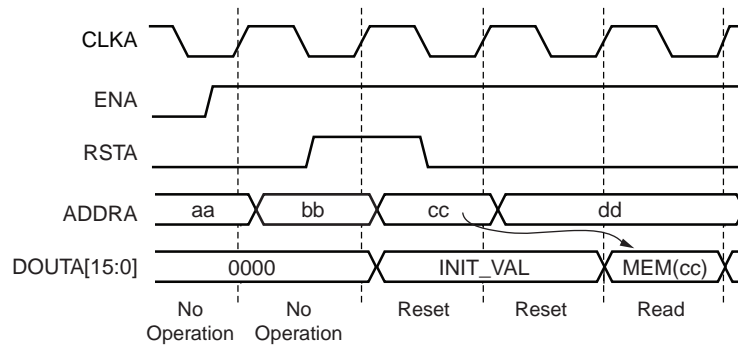

Figure 3-28: Special Reset Behavior using the Reset Memory Latch Option

The reset of the memory latch is gated by *en*, and the reset of the embedded register is gated by *ce*. As shown in Figure 3-29, both *ENA* and *REGCEA* are high at the time of the first reset, and the reset value is asserted at the output for two clock cycles. At the time of the second reset, *ena* is High, but *regcea* is Low; so the reset value does not appear at the output. At the time of the third reset, only *regcea* is High; so the reset value is asserted at the output for only one clock cycle.

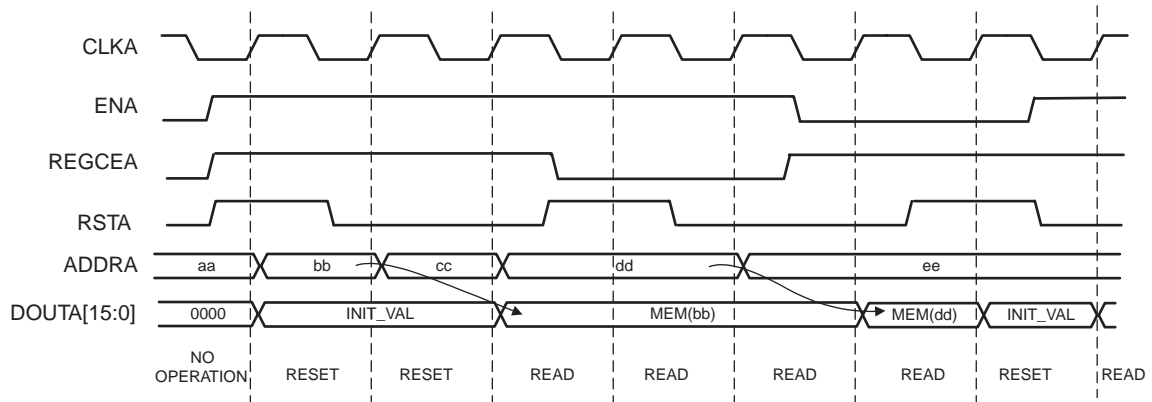

Figure 3-29: Reset Gated by CE with Reset Memory Latch Option

Controlling Reset Operations

The reset operation is dependent on the following generics:

- **Use RST[A|B] Pin:** These options determine the presence or absence of rst pins at the output of the core.
- **Reset Memory Latch (for Port A and Port B):** This option determines if the memory latch will be reset in addition to the embedded primitive output register for the respective port.
- **Reset Priority (for Port A and Port B):** This option determines the priority of clock enable over reset or reset over clock enable for the respective port.

In addition to the above options, the options of output registers also affects reset functionality, since the option to reset the memory latch depends on these options. [Table 3-3](#) lists the dependency of the reset behavior with these parameters. In these configurations, the core output register does not exist. The reset behavior detailed in [Table 3-3](#) uses Port A as an example. The reset behavior for Port B is identical.

Table 3-3: Control of Reset Behavior for Single Port

Use rsta Pin	Register Port A Output of Memory Primitives	Reset Memory Latch	Reset Priority for Port A	Virtex-7 Device Reset Behavior
0	X	X	X	No control over reset
1	0	(cannot be selected)	"CE", "SR"	Since no primitive output register exists, the reset applies only to the latch. The priority of SR cannot be set for the latch. Therefore, reset occurs synchronously when the enable input is '1'. The reset value is asserted for only one clock cycle (only if input rst signal is high for only one clock and en is high continuously).
1	1	0	"CE"	The priority cannot be set for the latch. Therefore reset priority of "SR" is not supported. Reset occurs synchronously, and is dependent or independent of the input enable signal. Reset value asserted for one clock cycle (only if input rst signal is high for only one clock and regce is high continuously).
1	1	1	"CE", "SR"	The priority cannot be set for the latch. Therefore reset priority of "SR" is not supported. Both memory latch and embedded output register of primitive are reset. Reset occurs synchronously at both these stages, and is dependent or independent of the input enable signal. Reset value is asserted for at least two clock cycles when enable inputs of both stages are '1', and may be more depending on the input rst and enable signals. If rst is asserted when the latch en input is '1' and the register enable input is '0', the memory latch alone gets reset and this reset value gets output only when the register enable goes High.
1	1	0	"SR"	Not applicable.
1	1	1	"SR"	Not applicable.
1	X	X	"SR", "CE"	Not applicable.

Built-in Error Correction Capability and Error Injection

The Block Memory Generator core supports built-in Hamming Error Correction Capability (ECC) for the block RAM primitives. For device support, see [Table 3-4](#). Each Write operation generates eight protection bits for every 64 bits of data, which are stored with the data in memory. These bits are used during each Read operation to correct any single-bit error, or to detect (but not correct) any double-bit error.

Table 3-4: Hard ECC Data width Support

	Zynq-7000	7 Series
Block RAM Mode	SDP Mode + Read First	SDP Mode + Read First
Supported Data Widths	≥ 64	≥ 64
Bit Error Insertion Support	Yes	Yes

This operation is transparent to the user. Two status outputs (`sbiterr` and `dbiterr`) indicate the three possible Read results: no error, single error corrected, and double error detected. For single-bit errors, the Read operation does not correct the error in the memory array; it only presents corrected data on `dout`. `BuiltIn_ECC` is only available when the Simple Dual-port RAM memory type is selected.

When using `BuiltIn_ECC`, the Block Memory Generator constructs the memory from special primitives available in the FPGA architectures. The `BuiltIn_ECC` memory block is 512x64, and is composed of two 18k block RAMs combined with dedicated `BuiltIn_ECC` encoding and decoding hardware. The 512x64 primitives are used to build memory sufficient for the desired user memory space.

The `BuiltIn_ECC` primitives calculate `BuiltIn_ECC` for a 64-bit wide data input. If the data width chosen by a user is not an integral multiple of 64 (for example, there are spare bits in any `BuiltIn_ECC` primitive), then a double-bit error (`dbiterr`) may indicate that one or more errors have occurred in the spare bits. So, the accuracy of the `dbiterr` signal cannot be guaranteed in this case. For example, if the user's data width is 32, then 32 bits of the primitive are left spare. If two of the spare bits are corrupted, the `dbiterr` signal would be asserted even though the actual user data is not corrupt.

When using `BuiltIn_ECC`, the following limitations apply:

- Byte-Write enable is not available
- All port widths must be identical
- Read First Operating Mode is supported
- Use `RST[A|B]` Pin and the Output Reset Value options are not available
- Memory Initialization is not supported
- No Algorithm selection is available

Figure 3-30 illustrates a typical Write and Read operation for a Block Memory Generator core in Simple Dual-port RAM mode with `BuiltIn_ECC` enabled, and no additional output registers.

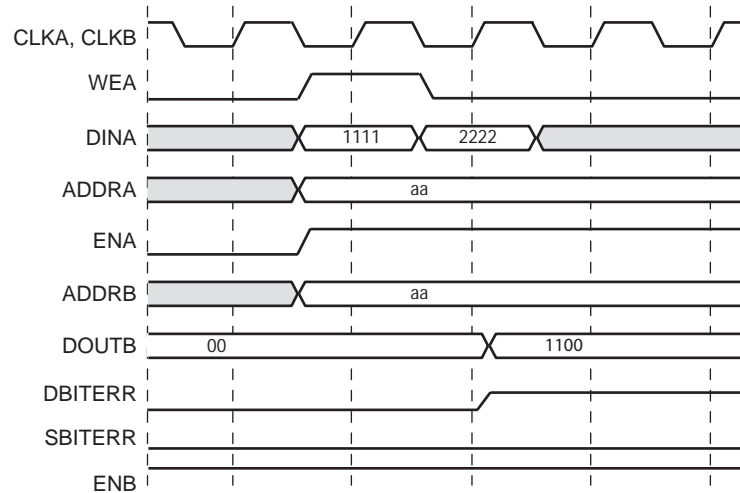

Figure 3-30: Read and Write Operation with BuiltIn_ECC

Error Injection

The Block Memory Generator core supports error injection through two optional pins: `injectsbiterr` and `injectdbiterr`. Users can use these optional error injection pins as debug pins to inject single or double-bit errors into specific locations during Write operations. The user can then check the assertion of the `sbiterr` and `dbiterr` signals at the output of those addresses. The user has the option to have no error injection pins, or to have only one or both of the error injection pins.

The `RDADDRECC` output port indicates the address at which a `sbiterr` or `dbiterr` has occurred. The `rdaddrecc` port, the two error injection ports, and the two error output ports are optional and become available only when the `BuiltIn_ECC` option is chosen. If the `BuiltIn_ECC` feature is not selected by the user, the primitive's `injectsbiterr` and `injectdbiterr` ports are internally driven to '0', and the primitive's outputs `sbiterr`, `dbiterr`, and `rdaddrecc` are not connected externally.

Figure 3-31 shows the assertion of the `sbiterr` and `dbiterr` output signals when errors are injected through the error injection pins during a Write operation.

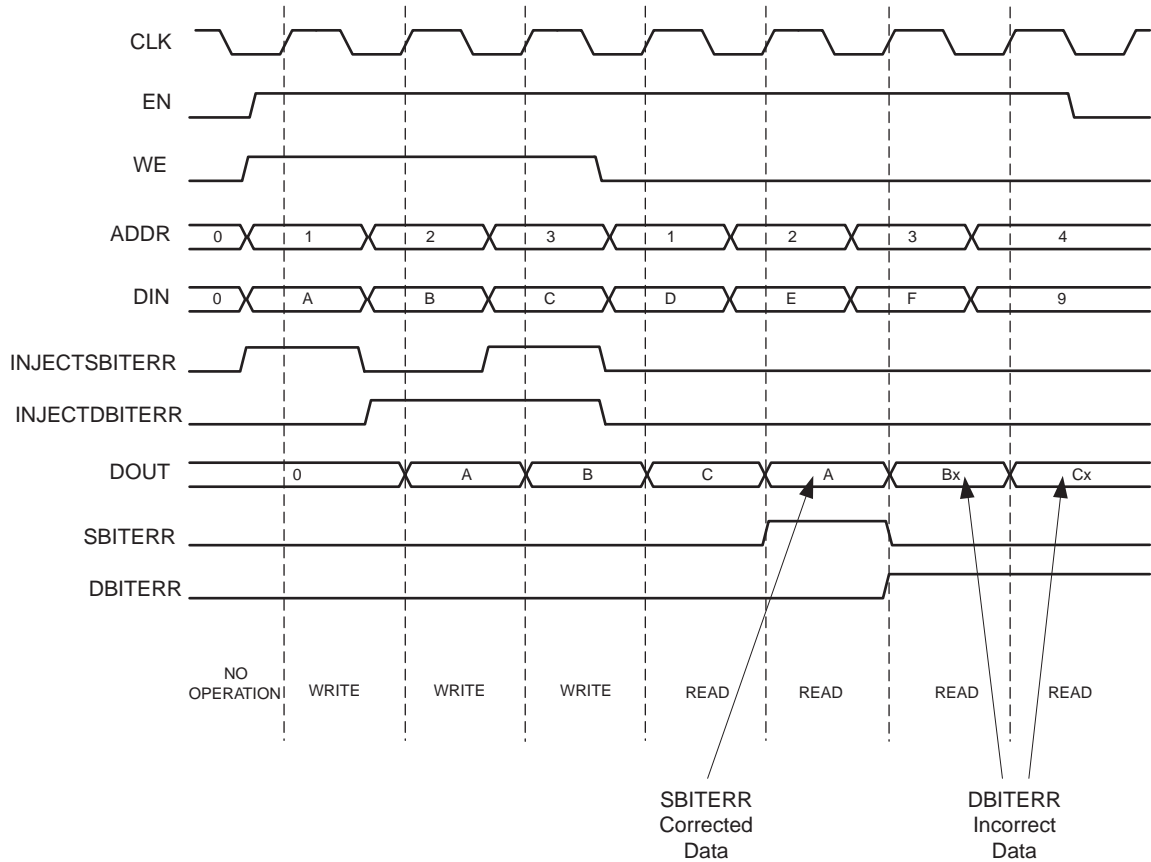

Figure 3-31: Assertion of SBITERR and DBITERR Signals by Using Error Injection Pins

When the `injectsbiterr` and `injectdbiterr` inputs are asserted together at the same time for the same address during a Write operation (as in the case of address 3 in Figure 3-31), the `injectdbiterr` input takes precedence, and only the `dbiterr` output is asserted for that address during a Read operation. The data output for this address is not corrected.

Soft Error Correction Capability and Error injection

This section describes the implementation and usage of the Soft Error Correction Control (Soft ECC) module that is supported in the Block Memory Generator.

Overview

The Soft ECC module detects and corrects all single-bit errors in a code word consisting of up to 64 bits of data and up to eight parity bits. In addition, it detects double-bit errors in the data. This design uses Hamming code, which is an efficient method for ECC operations.

Features

- Supports Soft ECC for data widths less than or equal to 64 bits

- Uses Hamming error code correction
 - Single-bit errors are corrected
 - Double-bit errors are detected
- Supports Simple Dual-port RAM memory type
- Supports optional Input and/or Output Registering stages
- Supported Block Memory Generator features include:
 - Minimum Area, Fixed Primitive and Low Power Algorithms
 - Mux Pipelining Stages
 - Embedded Primitive Registers
 - Core Output Registers
 - Optional Enable Inputs
- Fully parameterized implementation enables optimization of resources

Details

Each Write operation generates between 4 and 8 protection bits for 1 to 64 bits of data, which are stored with the data in memory. These bits are used during each Read operation to correct any single-bit error, or to detect (but not correct) any double-bit error.

The two status outputs (`sbiterr` and `dbiterr`) indicate the three possible Read results: no error, single error corrected, and double error detected. For single-bit errors, the Read operation does not correct the error in the memory array; it only presents corrected data on DOUT.

When using Soft ECC, the Block Memory Generator can construct the memory from the available primitives. The Soft ECC feature is implemented as an overlay on top of the Block Memory Generator core. This allows users to select algorithm options and registering options in the core. When Soft ECC is selected, limited core options include:

- Byte-Write enable is not available
- All port widths must be identical
- Use RST[A|B] Pin and the Output Reset Value options are not available
- Memory Initialization is not supported

The Soft ECC implementation is optimized to generate the core for different data widths, as shown in [Table 3-5](#). For the selected data width, the number of check bits appended is shown in [Table 3-6](#). The operation of appending the additional check bits for the given data width is done within the Block Memory Generator core and is transparent to the user.

Table 3-5: Soft ECC Data width Support

	Zynq-7000	7 Series
Block RAM mode	SDP Mode	SDP Mode
Supported Data Widths	≤ 64 bits	≤ 64 bits
Bit Error Insertion Support	Yes	Yes

Table 3-6: Memory Width Calculation for Selected User Data Width

User Input Data Width	Added Check Bits	Total Memory Width in Bits
1-4	4	5-8
5-11	5	10-16
12-26	6	18-32
27-57	7	34-64
58-64	8	66-72

Figure 3-32 illustrates the implementation of Soft ECC logic for the Block Memory Generator core. The implementation shown in Figure 3-32 is for 64 bits of data; the implementation is parameterized for other data widths.

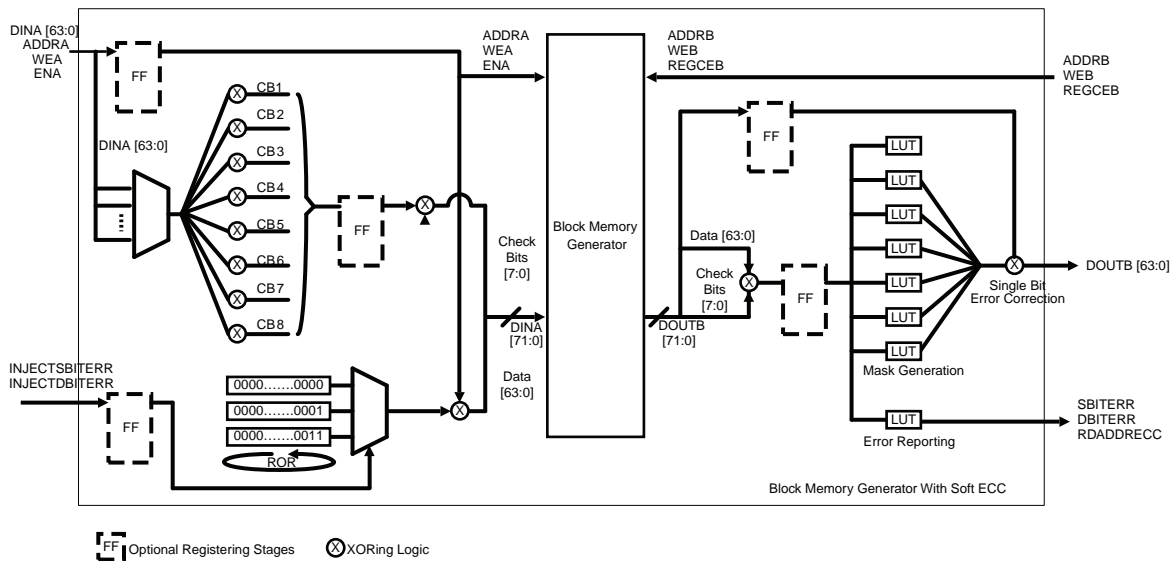

Figure 3-32: Block Memory Generator with Soft ECC

The optional input and output registering stages can be enabled by setting the values of parameters `register_porta_input_of_softecc` and `register_portb_output_of_softecc` appropriately. These registers improve the performance of the Soft ECC logic. By default, the input and output registering stages are disabled.

With Soft ECC, error injection is supported through two optional pins: `injectsbiterr` and `injectdbiterr`. The error injection operation is performed on both data bits and added check bits. Users can use these optional error injection pins as debug pins to inject

single or double-bit errors into specific locations during Write operations. Then, the user can check the assertion of the `sbiterr` and `dbiterr` signals at the output of those addresses. The user may select no error injection pins, one error injection pin or both.

The `RDADDRECC` output port indicates the address at which a single or double-bit error has occurred. The `RDADDRECC` port, the two error injection ports, and the two error output ports are optional and become available only when the Soft ECC option is chosen. If the Soft ECC feature is not selected, the outputs `sbiterr`, `dbiterr`, and `rdaddrecc` are not connected externally.

Parameters

- **softecc**: This parameter enables the Soft ECC logic.
- **register_porta_input_of_softecc**: This parameter registers the input ports in the design.
- **register_portb_output_of_softecc**: This parameter registers the output ports in the design.
- **use_error_injection_pins**: This parameter enables single and/or double-bit error injection capability during Write operations
- **error_injection_type**: This parameter specifies the type of the error injection done in the Soft ECC logic. The error injection type can be either "Single_Bit_Error_Injection" or "Double_Bit_Error_Injection" or "Single_and_Double_Bit_Error_Injection."

Parameter - Port dependencies

- When the **softecc** parameter is enabled: `sbiterr`, `dbiterr`, and `rdaddrecc` ports are made available on the IO interface.
- When the **use_error_injection_pins** parameter is enabled and "Single_Bit_Error_Injection" option is selected: `injectsbiterr` port is made available on the IO interface.
- When the **use_error_injection_pins** parameter is enabled and "Double_Bit_Error_Injection" option is selected: `injectdbiterr` port is made available on the IO interface
- When the **use_error_injection_pins** parameter is enabled and "Single_and_Double_Bit_Error_Injection" option is selected: `injectsbiterr` and `injectdbiterr` ports are made available on the IO interface

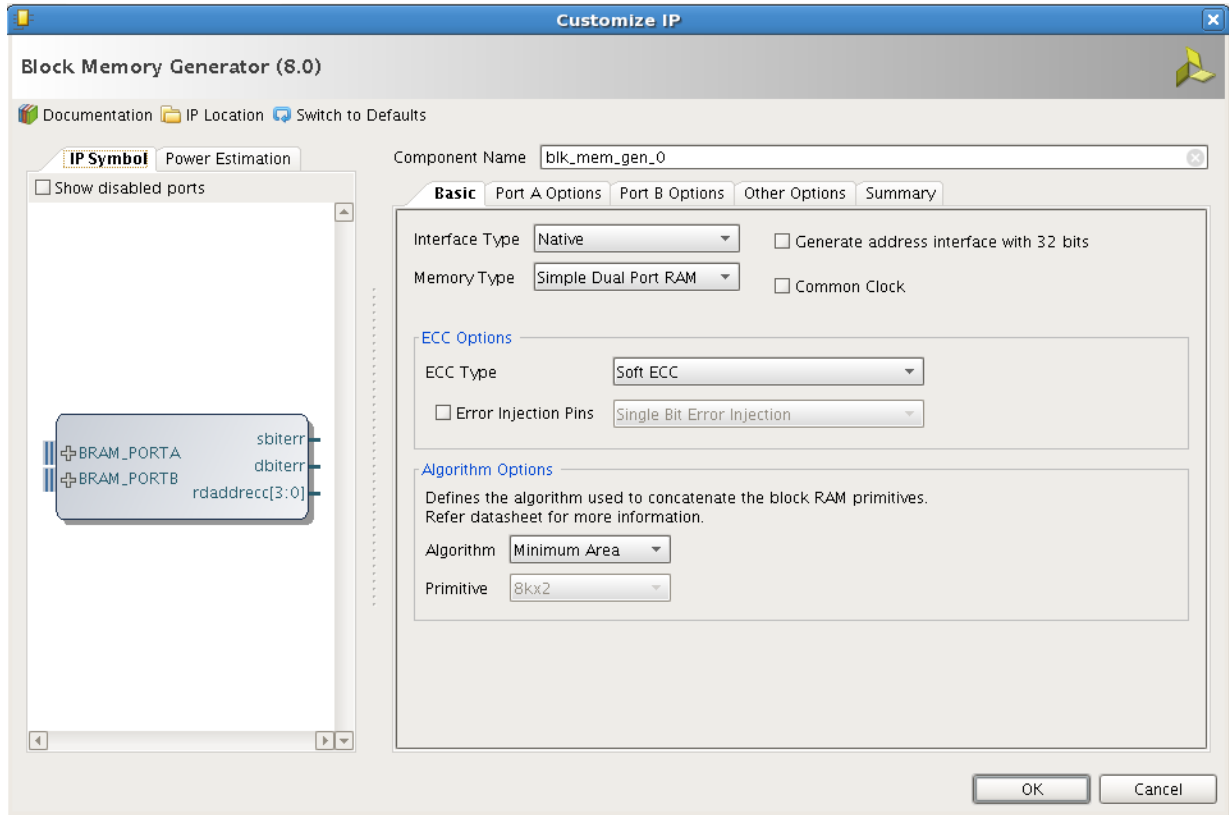

Figure 3-33: Enabling Soft ECC Option

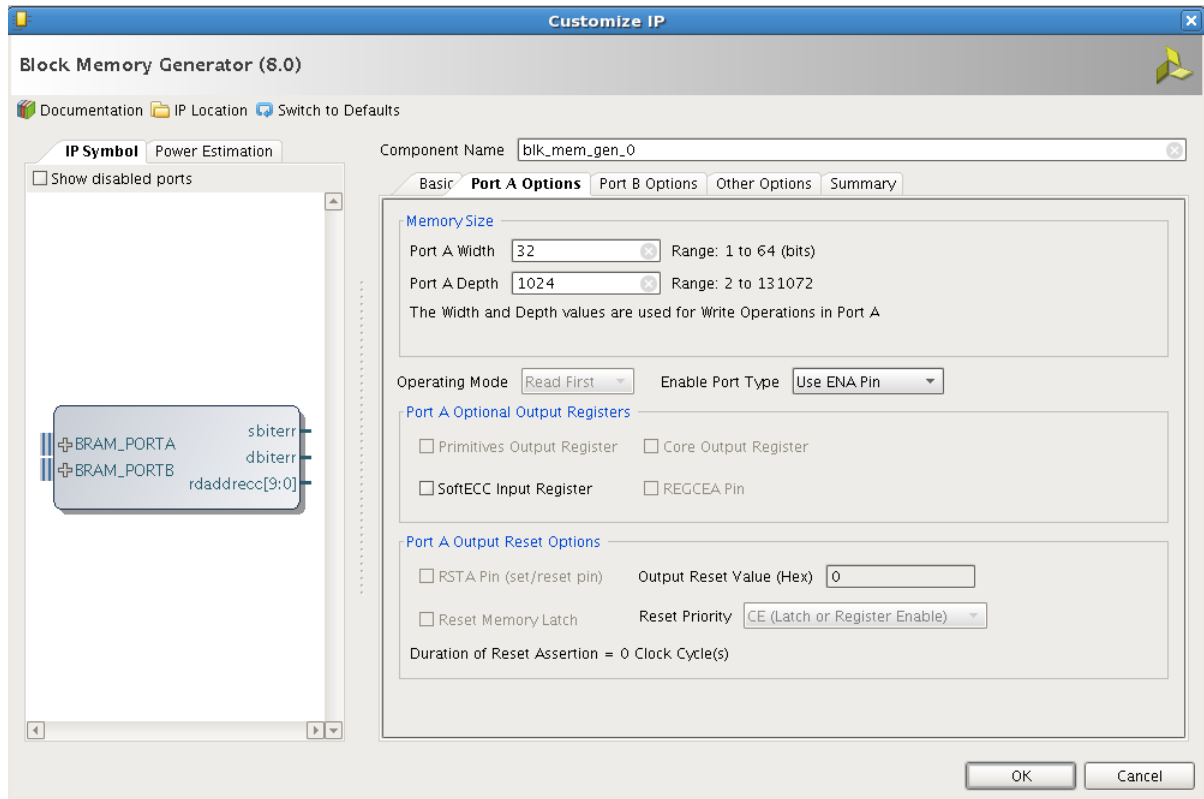

Figure 3-34: Enabling Input Registering Stages

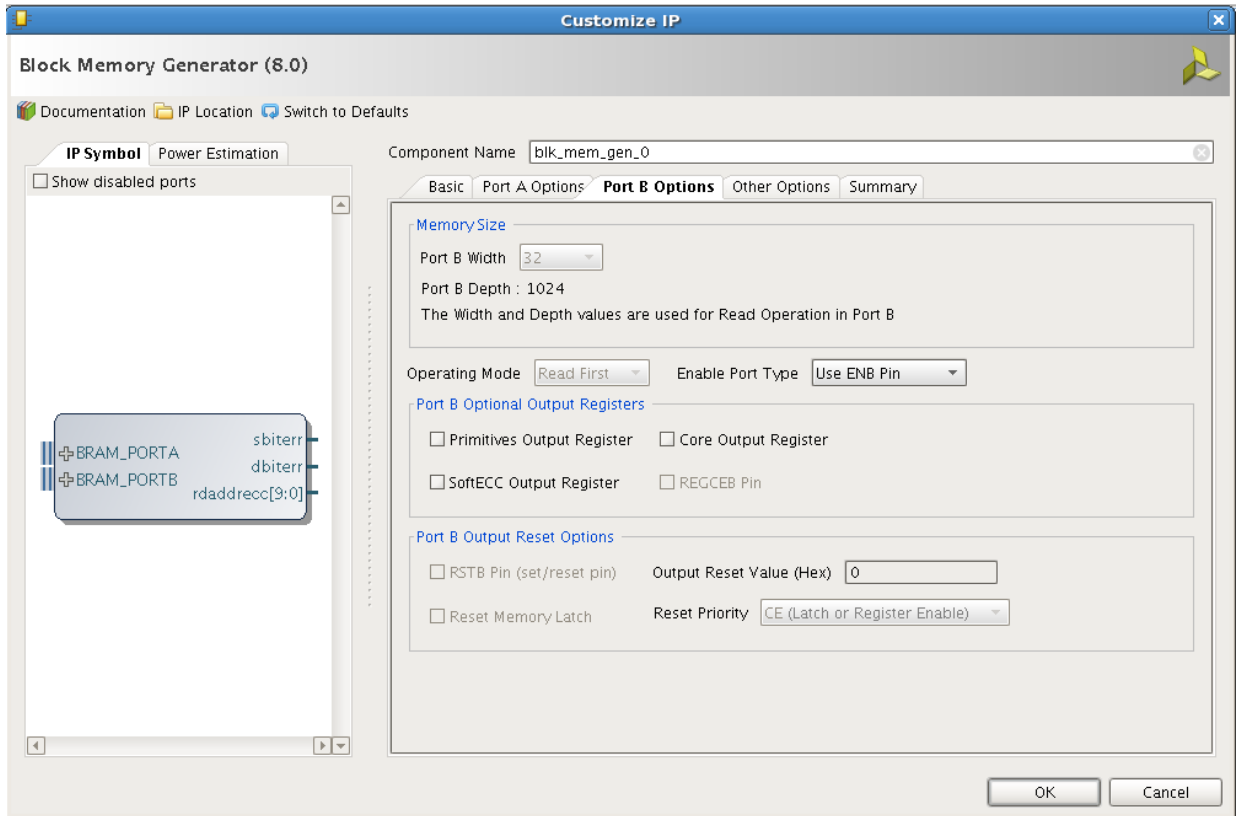

Figure 3-35: Enabling Output Registering Stages

Timing Diagrams

Figure 3-36 illustrates a typical Write and Read operation for a core with a simple dual-port RAM configuration with Soft ECC enabled and no additional input or output registers.

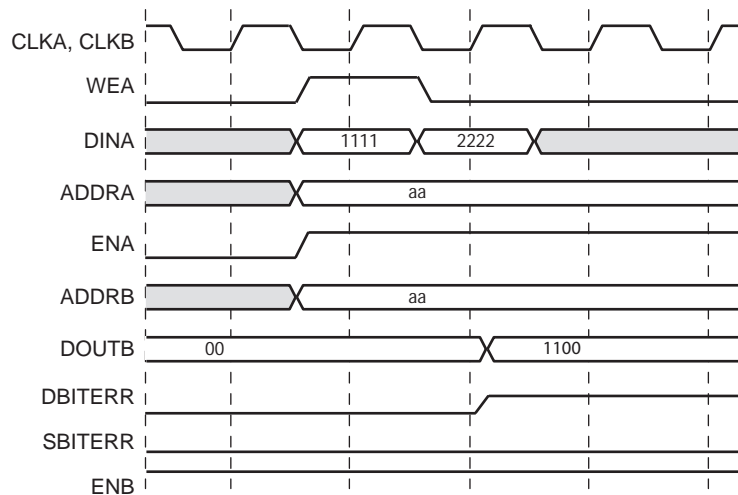

Figure 3-36: Read and Write Operations with Soft ECC

Figure 3-37 shows the assertion of the `sbiterr` and `dbiterr` output signals when errors are injected through the error injection pins during a Write operation.

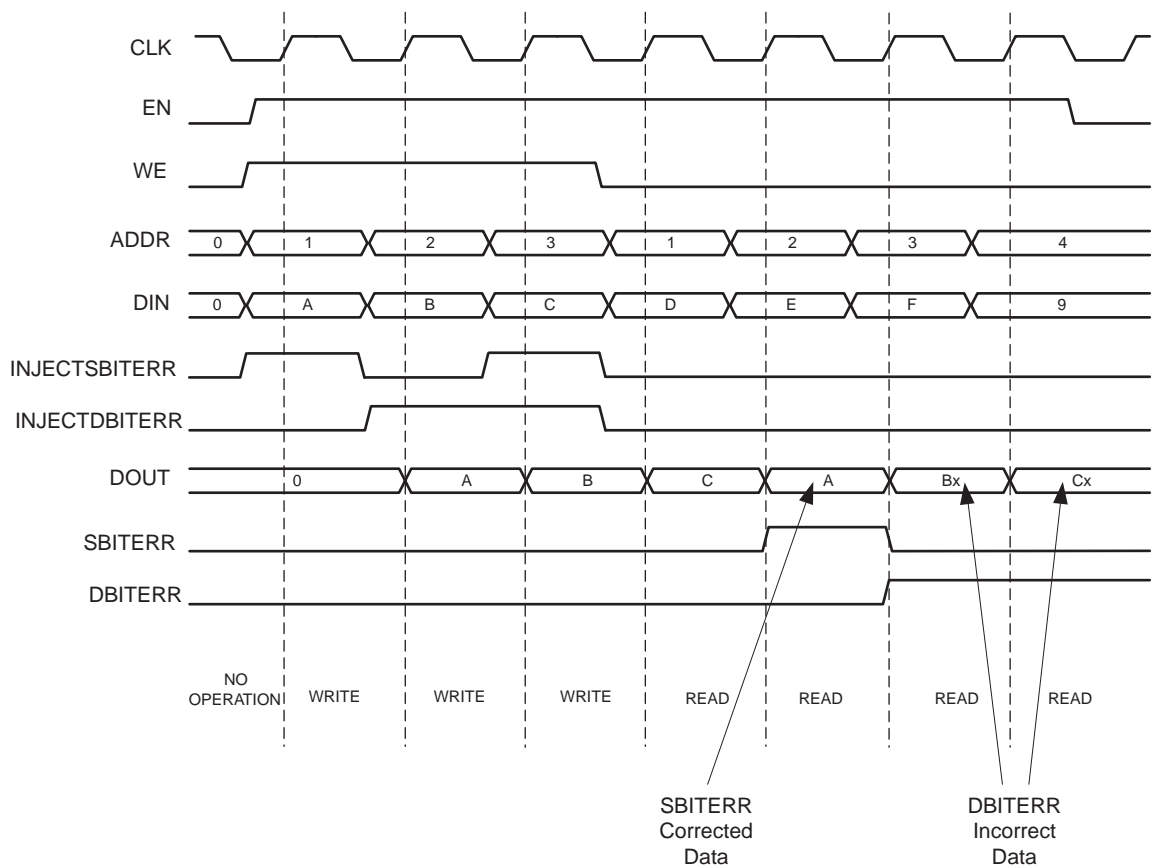

Figure 3-37: Assertion of SBITERR and DBITERR Signals

When the `injectsbiterr` and `injectdbiterr` inputs are asserted together at the same time for the same address during a Write operation (address 3 in Figure 3-37), then the `injectdbiterr` input takes precedence. Only the `dbiterr` output is asserted for that address during a Read operation. The data output for this address is not corrected.

Device Utilization and Performance Benchmarks

Table 3-7: Resource utilization for Virtex-7 Devices (XC7VX550T-FFG1927-1)^{a b}

Depth x Width	Mode	Check Bits	Resource Utilization ^c			Performance ^d
			Block RAMs	Slice LUTs	FF	Max Freq (MHz)
1Kx8	W/o ECC		1	0	0	368
	With ECC	5	1	32	10	352
1Kx16	W/o ECC		1	0	0	360
	With ECC	6	1	61	10	352

Table 3-7: Resource utilization for Virtex-7 Devices (XC7VX550T-FFG1927-1)^{a b} (Cont'd)

Depth x Width	Mode	Check Bits	Resource Utilization ^c			Performance ^d
			Block RAMs	Slice LUTs	FF	Max Freq (MHz)
1Kx32	W/o ECC		1	0	0	344
	With ECC	7	2	95	10	344
1Kx64	W/o ECC		2	0	0	352
	With ECC	8	2	181	10	288

- a. Uses Fixed Primitive Algorithm (Primitive Configuration is 512x36).
- b. Memory type is SDP.
- c. No register stage.
- d. Uses Memory Core Output Register.

Lower Data Widths in SDP Configurations

The SDP primitives support lower data widths. Width combinations are possible for Port A and Port B, as shown in [Table 3-8](#).

Table 3-8: Data Widths Supported by SDP Primitives⁽¹⁾⁽²⁾⁽³⁾

Primitive	Read Port Width	Write Port Width	Read Port Width	Write Port Width
RAMB18 SDP Primitive	x1	x32	x32	x1
	x2	x32	x32	x2
	x4	x32	x32	x4
	x9	x36	x36	x9
	x18	x36	x36	x18
	x36	x36	-	-
RAMB36 SDP Primitive	x1	x64	x64	x1
	x2	x64	x64	x2
	x4	x64	x64	x4
	x9	x72	x72	x9
	x18	x72	x72	x18
	x36	x72	x72	x36
	x72	x72	-	-

Notes:

- 1. Refer to [Additional Memory Collision Restrictions: Address Space Overlap](#), page 55.
- 2. The selection of SDP primitives depends on the algorithm selected.
- 3. Asymmetric data widths cause the SDP to be not selected.

Clocking

The Block Memory Generator core has two clocks: `clk_a` and `clk_b`. Depending on the configuration, one or two clocks can be enabled.

Resets

The Block Memory Generator core has two resets. Depending on the configuration, the core can have different reset operations as explained in [Optional Set/Reset Pins](#), [Reset Priority](#), and [Special Reset Behavior](#).

Customizing and Generating the Core

This chapter includes information on using Vivado tools to customize and generate the core.

Vivado Integrated Design Environment (IDE)

You can customize the IP for use in your design by specifying values for the various parameters associated with the IP core using the following steps:

1. Select the IP from the IP catalog. The Block Memory Generator is available in the Vivado IP catalog. To open the Block Memory core, go to **IP Catalog > Memories & Storage Elements > RAMs & ROMs**.
2. Double-click the selected IP or select the Customize IP command from the toolbar or popup menu.

For details, see the sections, “Working with IP” and “Customizing IP for the Design” in the *Vivado Design Suite User Guide: Designing with IP* (UG896) [Ref 5] and the “Working with the Vivado IDE” section in the *Vivado Design Suite User Guide: Getting Started* (UG910) [Ref 8].



IMPORTANT: For details about customizing this core with IP Integrator, see [Customizing the Core with IP Integrator](#).

Note: Figures in this chapter are illustrations of the Vivado IDE. This layout may vary from the current version. The actual Vivado IDE screens depend on the user configuration.

The following section defines the possible customization options in the Block Memory Generator Vivado IDE screens. The Native interface Block Memory Generator Vivado IDE includes six main screens:

- [Native Block Memory Generator First Screen](#)
- [Port Options Screen](#)
- [Other Options Screen](#)
- [Summary Screen](#)
- [Power Estimate Options Screen](#)

- [Interface Type Selection Screen](#)
- [AXI4 Interface Options Screen](#)

In addition, all the screens share common tabs and buttons to provide information about the core and to navigate the Block Memory Generator Vivado IDE.

Native Block Memory Generator First Screen

The main Block Memory Generator screen is used to define the component name and provides the Interface Options for the core.

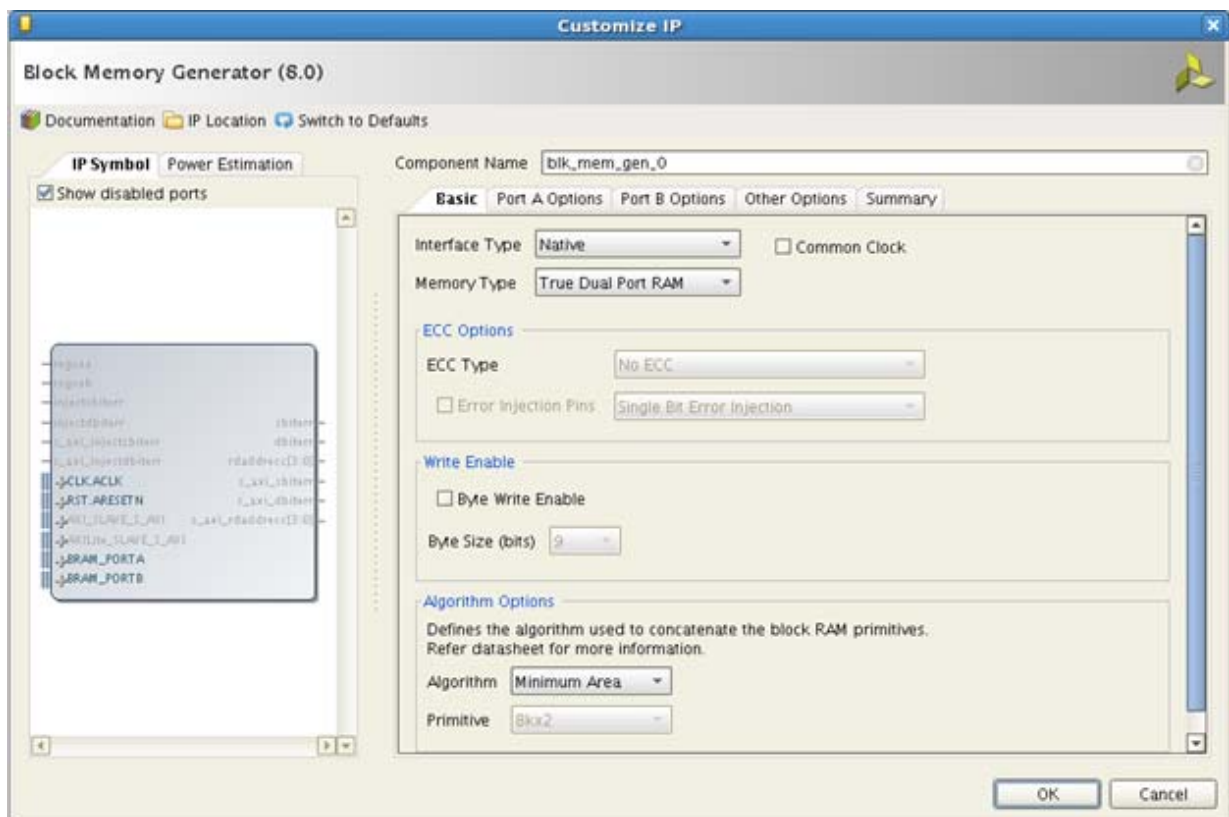

Figure 4-1: Block Memory Generator Main Screen

- **Interface Type**
 - Native: Implements a Native Block Memory Generator Core compatible with previously released versions of the Block Memory Generator.
- **Memory Type:** Select the type of memory to be generated.
 - Single-port RAM
 - Simple Dual-port RAM
 - True Dual-port RAM

- Single-port ROM
- Dual-port ROM
- **ECC Options:** When the Simple dual-port RAM memory type is selected, the ECC Type option becomes available. It provides the user the choice to select the type of ECC required.
 - Built-In ECC: When the selected ECC Type is BuiltIn_ECC, the built-in Hamming Error Correction is enabled.

The Use Error Injection Pins option is available for selection if the ECC option is selected. This option enables error injection pins. On choosing this option, additional options are available to have Single-Bit Error Injection (INJECTSBITERR), Double-Bit Error Injection (INJECTDBITERR), or both. See [Hamming Error Correction Capability in Chapter 1](#) for more information.

When using ECC, the following limitations apply:

- Byte-Write Enable is not available.
- All port widths must be identical.
- Read First Operating Mode is supported when the **Common Clock** option is selected.
- The Use RST[A|B] Pin and the Output Reset Value options are not available.
- Memory Initialization is not supported.
- No algorithm selection is available.
- Generating a 32-bit address interface is not supported.
- Soft ECC: When the selected ECC Type is Soft_ECC, soft error correction (using Hamming code) is enabled.

The Use Error Injection Pins option is available for selection if the Soft ECC option is selected. This option enables error injection pins. On choosing this option, additional options are available to have Single-Bit Error Injection (INJECTSBITERR), Double-Bit Error Injection (INJECTDBITERR), or both. See [Soft Error Correction Capability and Error injection in Chapter 3](#) for more information about this option and the limitations that apply.

When using Soft ECC, the following conditions apply:

- Supports Soft ECC for data widths less than or equal to 64 bits
- Uses Hamming error code correction: Single-bit errors are corrected and double-bit errors are detected.
- Supports Simple Dual-port RAM memory type
- Supports optional Input and/or Output Registering stages

- Supported Block Memory Generator features include:
 - Minimum Area, Fixed Primitive and Low Power Algorithms
 - Mux Pipelining Stages
 - Embedded Primitive Registers
 - Core Output Registers
 - Optional Enable Inputs
- Fully parameterized implementation for optimized resource utilization
- **Common Clock:** Select the Common Clock option when the clock (CLKA and CLKB) inputs are driven by the same clock buffer.



IMPORTANT: For devices with `COMMON_CLOCK` selected, `WRITE_MODE` is set as `READ_FIRST` for Simple Dual Port RAM Memory type, otherwise `WRITE_MODE` is set as `WRITE_FIRST`.

- **Write Enable:** Selects whether to use the byte-Write enable feature. Byte size is either 8-bits (no parity) or 9-bits (including parity). The data width of the memory will be multiples of the selected byte-size.
- **Algorithm:** Select the algorithm used to implement the memory:
 - **Minimum Area Algorithm:** Generates a core using the least number of primitives.
 - **Low Power Algorithm:** Generates a core such that the minimum number of block RAM primitives are enabled during a Read or Write operation.
 - **Fixed Primitive Algorithm:** Generates a core that concatenates a single primitive type to implement the memory. Choose which primitive type to use in the drop-down list.

Port Options Screen

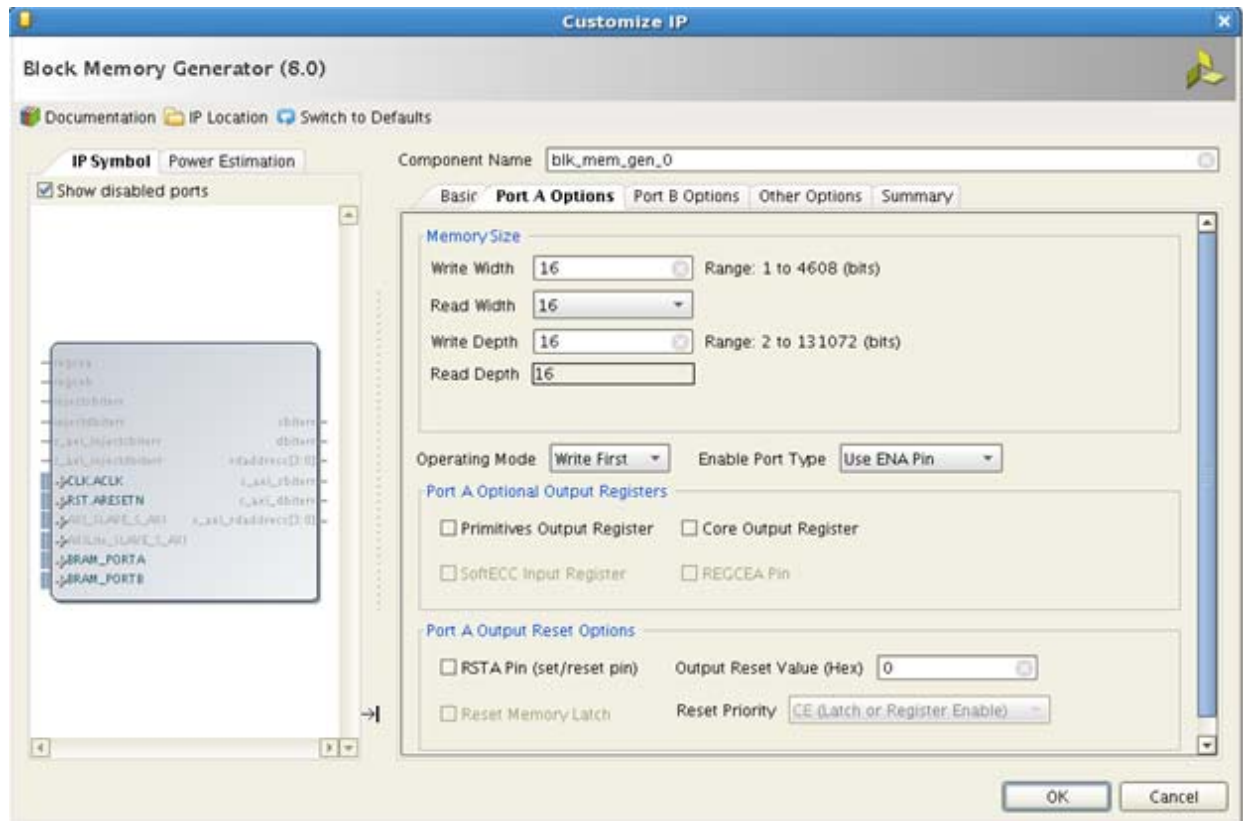

Figure 4-2: Port A Options

- **Memory Size:** Specify the port [A|B] Write width and depth. Select the port [A|B] Read width from the drop-down list of valid choices. The Read depth is calculated automatically.
- **Operating Mode:** Specify the port [A|B] operating mode.
 - READ_FIRST
 - WRITE_FIRST
 - NO_CHANGE
- **Enable Port Type:** Select the enable type:
 - Always enabled (no ENA | ENB pin available)
 - Use ENA | ENB pin
- **Port [A|B] Optional Output Registers:** Select the output register stages to include:
 - Primitives Output Register: Select to insert output register after the memory primitives for port A and port B separately. The embedded output registers in the block RAM primitives are used if the user chooses to register the output of the

memory primitives. See [Output Register Configurations in Appendix D](#) for more information.

- Core Output Register: Select for each port (A or B) to insert a register on the output of the memory core for that port. When selected, registers are implemented using FPGA slices to register the core's output.
- REGCE[A|B] Pin: Select to use a separate REGCEA or REGCEB input pin to control the enable of the last output register stage in the memory. When unselected, all register stages are enabled by ENA/ENB.
- **Port [A|B] Output Reset Options**
 - Use RST[A|B] Pin (Set/Reset Pin): Choose whether a set/reset pin (RST[A|B]) is needed.
 - Reset Priority: The Reset Priority option for each port is available only when the Use RST Pin option of the corresponding port is chosen. The user can set the reset priority to either CE or SR. For more information on the reset priority feature, see Reset Priority in Chapter 3.
 - Reset Behavior: The Reset Behavior (Reset Memory Latch) options for each port are available only when the Use RST Pin option and the Register Output of Memory Primitives option of the corresponding port are chosen, and the Register Memory Core option of the corresponding port is not chosen.
 - The Reset Memory Latch option modifies the behavior of the reset and changes the duration for which the reset value is asserted. The minimum duration of reset assertion is displayed as information in the GUI based upon the choice for this option. For more information on the Reset Memory Latch option, see Special Reset Behavior in Chapter 3.
 - Output Reset Value (Hex): Specify the reset value of the memory output latch and output registers. These values are with respect to the Read port widths.

Other Options Screen

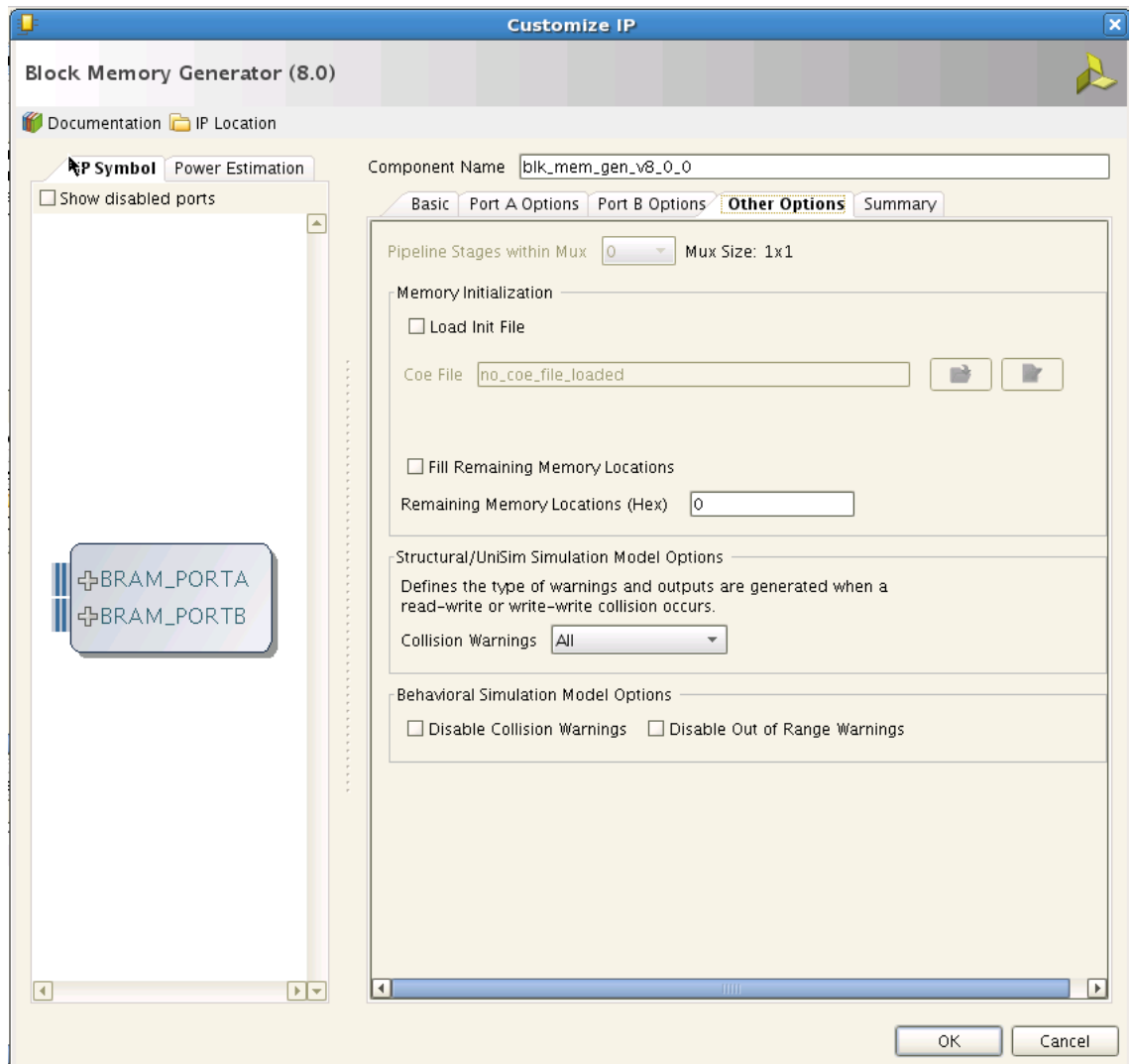

Figure 4-3: Other Options Screen

- **Pipeline Stages within Mux:** Available only when the Register Output of Memory Core option is selected for both port A and port B and when the constructed memory has more than one primitive in depth, so that a MUX is needed at the output. Select a value of 0, 1, 2, or 3 from the drop-down list.

The MUX size displayed in the GUI can be used to determine the number of pipeline stages to use within the MUX. Select the appropriate number of pipeline stages for your design based on the device architecture.

- **Memory Initialization:** Select whether to initialize the memory contents using a COE file, and whether to initialize the remaining memory contents with a default value. When using asymmetric port widths or data widths, the COE file and the default value are with respect to the port A Write width.

- **Structural/UNISIM Simulation Model Options:** Select the type of warning messages and outputs generated by the structural simulation model in the event of collisions. For the options of ALL, WARNING_ONLY and GENERATE_X_ONLY, the collision detection feature will be enabled in the UniSim models to handle collision under any condition.

The NONE selection is intended for designs that have no collisions and clocks (Port A and Port B) that are never in phase or within 3000 ps in skew. If NONE is selected, the collision detection feature will be disabled in the models, and the behavior during collisions is left for the simulator to handle. So, the output will be unpredictable if the clocks are in phase or from the same clock source or within 3000 ps in skew, and the addresses are the same for both ports. The option NONE is intended for design with clocks never in phase.

- **Behavioral Simulation Model Options:** Select the type of warning messages generated by the behavioral simulation model. Select whether the model should assume synchronous clocks (Common Clock) for collision warnings.

Summary Screen

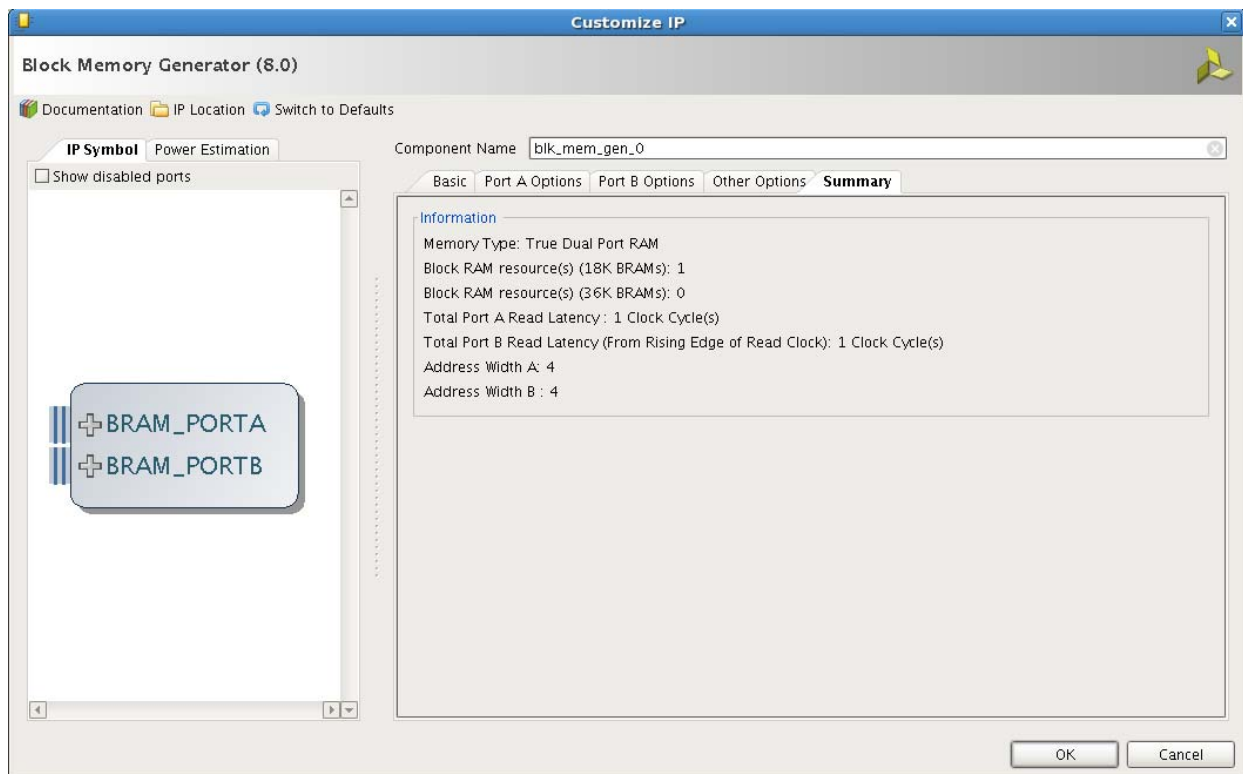

Figure 4-4: Summary Screen

Power Estimate Options Screen

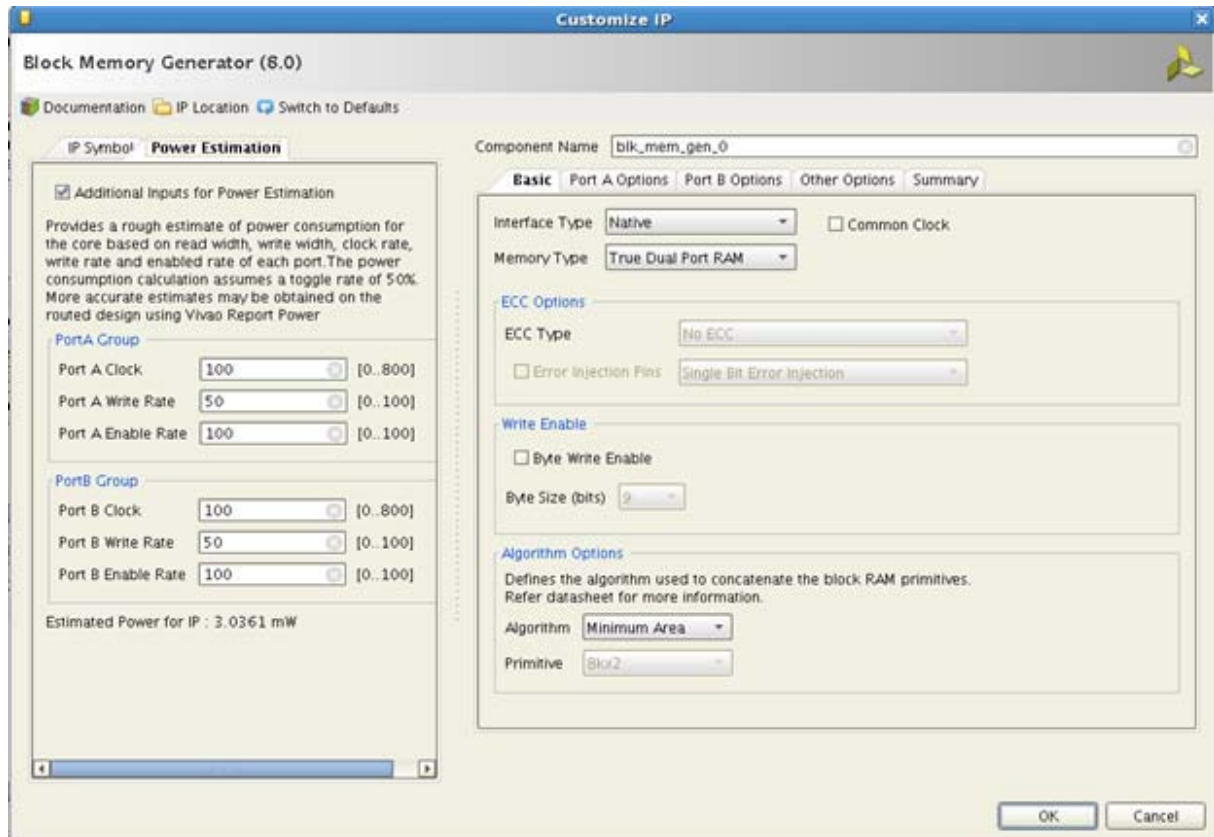

Figure 4-5: Power Estimate Options Screen

The Power Estimation tab on the left side of the GUI screen shown in [Figure 4-5](#) provides a rough estimate of power consumption for the core based on the configured Read width, Write width, clock rate, Write rate and enable rate of each port. The power consumption calculation assumes a toggle rate 50%. More accurate estimates can be obtained on the routed design using the XPower Analyzer tool. See www.xilinx.com/power for more information on the XPower Analyzer.

The screen has an option to provide "Additional Inputs for Power Estimation" apart from configuration parameters. The following parameters can be entered by the user for power calculation:

- **Clock Frequency [A|B]:** The operating clock frequency of the two ports A and B respectively.
- **Write Rate [A|B]:** Write rate of ports A and B respectively.
- **Enable Rate [A|B]:** Average access rate of port A and B respectively.

Information Section

This section displays an informational summary of the selected core options.

- **Memory Type:** Reports the selected memory type.
- **Block RAM Resources:** Reports the exact number of 18K and 36K block RAM primitives which will be used to construct the core.
- **Total Port A Read Latency:** The number of clock cycles for a Read operation for port A. This value is controlled by the optional output registers options for port A on the previous screen.
- **Total Port B Read Latency:** The number of clock cycles for a Read operation for port B. This value is controlled by the optional output registers options for port B on the previous screen.
- **Address Width:** The actual width of the address bus to each port.

Specifying Initial Memory Contents

The Block Memory Generator core supports memory initialization using a memory coefficient (COE) file or the default data option in the Vivado IP Catalog GUI, or a combination of both.

The COE file can specify the initial contents of each memory location, while default data specifies the contents of all memory locations. When used in tandem, the COE file can specify a portion of the memory space, while default data fills the rest of the remaining memory space. COE files and default data is formatted with respect to the port A Write width (or port A Read width for ROMs).

A COE is a text file which specifies two parameters:

- **memory_initialization_radix:** The radix of the values in the memory_initialization_vector. Valid choices are 2, 10, or 16.
- **memory_initialization_vector:** Defines the contents of each memory element. Each value is LSB-justified and assumed to be in the radix defined by memory_initialization_radix.

The following is an example COE file. Note that semi-colon is the end of line character.

```
; Sample initialization file for a
; 8-bit wide by 16 deep RAM
memory_initialization_radix = 16;
memory_initialization_vector =
12, 34, 56, 78, AB, CD, EF, 12, 34, 56, 78, 90, AA, A5, 5A, BA;
```

Coefficients can be separated by a space, a comma, or by placing one value in each line with a carriage return.

Block RAM Usage

The Information panel (screen 5 of the Block Memory Generator GUI) reports the actual number of 18K and 36K block RAM blocks to be used.

To estimate this value when using the fixed primitive algorithm, the number of block RAM primitives used is equal to the width ratio (rounded up) multiplied by the depth ratio (rounded up), where the width ratio is the width of the memory divided by the width of the selected primitive, and the depth ratio is the depth of the memory divided by the depth of the primitive selected.

To estimate block RAM usage when using the low power algorithm requires a few more calculations:

- If the memory width is an integral multiple of the width of the widest available primitive for the chosen architecture, then the number of primitives used is calculated in the same way as the fixed primitive algorithm. The width and depth ratios are calculated using the width and depth of the widest primitive. For example, for a memory configuration of 2kx72, the width ratio is 2 and the depth ratio is 4 using the widest primitive of 512x36. As a result, the total available primitives used is 8.
- If the memory width is greater than an integral multiple of the widest primitive, then in addition to the above calculated primitives, more primitives are needed to cover the remaining width. This additional number is obtained by dividing the memory depth by the depth of the additional primitive chosen to cover the remaining width. For example, a memory configuration of 17kx37 requires one 512x36 primitive to cover the width of 36, and an additional 16kx1 primitive to cover the remaining width of 1. To cover the depth of 17K, 34 512x36 primitives and 2 16kx1 primitives are needed. As a result, the total number of primitives used for this configuration is 36.
- If the memory width is less than the width of the widest primitive, then the smallest possible primitive that covers the memory width is chosen for the solution. The total number of primitives used is obtained by dividing the memory depth by the depth of the chosen primitive. For example, for a memory configuration of 2kx32, the chosen primitive is 512x36, and the total number of primitives used is 2k divided by 512, which is 4.

When using the minimum area algorithm, it is not as easy to determine the exact block RAM count. This is because the actual algorithms perform complex manipulations to produce optimal solutions. The optimistic estimate of the number of 18K block RAMs is total memory bits divided by 18k (the total number of bits per primitive) rounded up. Given that this algorithm packs block RAMs very efficiently, this estimate is often very accurate for most memories.

LUT Utilization and Performance

The LUT utilization and performance of the core are directly related to the arrangement of primitives and the selection of output registers. Particularly, the number of primitives cascaded in depth to implement a memory determines the size of the output multiplexer and the size of the input decoder, which are implemented in the FPGA fabric.

Note: Although the primary goal of the minimum area algorithm is to use the minimum number of block RAM primitives, it has a secondary goal of maximizing performance – as long as block RAM usage does not increase.

Generating the AXI4 Interface Block Memory Generator Core

The AXI4 Interface Block Memory Generator GUI includes two additional screens followed by Native BMG configuration screens:

- [Interface Type Selection Screen](#)
- [AXI4 Interface Options Screen](#)

Interface Type Selection Screen

The main Block Memory Generator screen is used to define the component name and provides the Interface Options for the core.

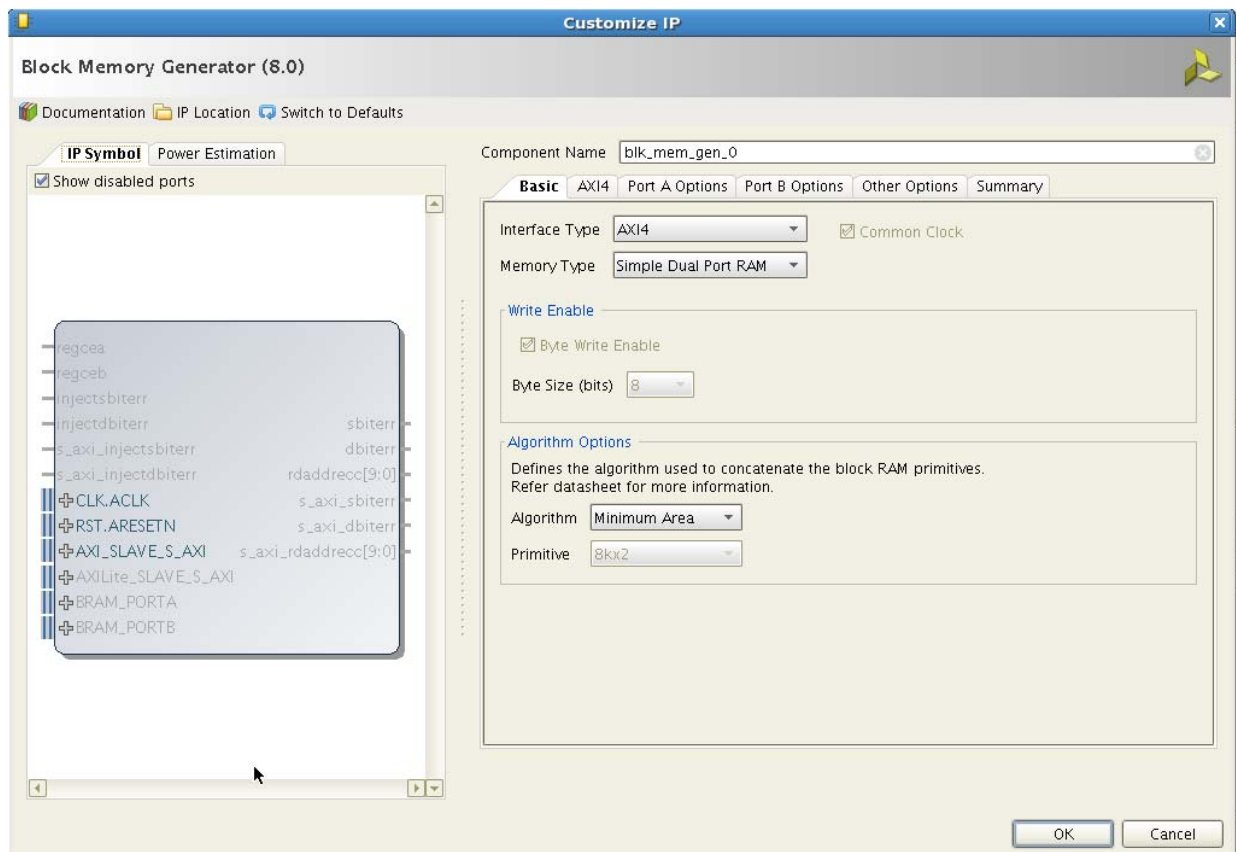

Figure 4-6: AXI4 Interface Selection Screen of Block Memory Generator

Component Name

Base name of the output files generated for this core. The name must begin with a letter and be composed of the following characters: a to z, 0 to 9, and “_”.

- **Interface Type:**
 - AXI4: Implements an AXI4 Interface Block Memory Generator Core.

AXI4 Interface Options Screen

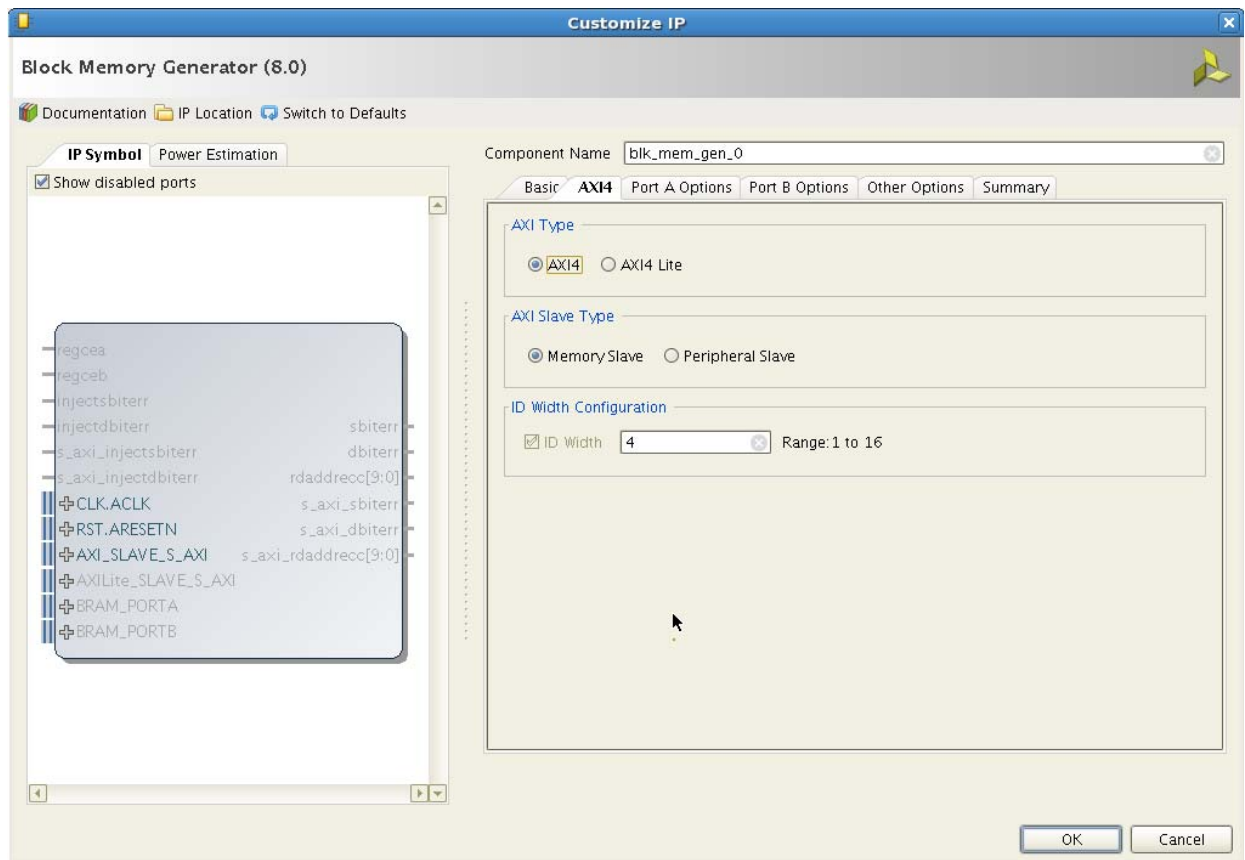

Figure 4-7: AXI4 Interface Options

- **AXI4 Interface Options:**
 - AXI4: Implements an AXI4 Block Memory Generator Core.
 - AXI4-Lite: Implements an AXI4-Lite Block Memory Generator Core.
- **AXI4 Slave Options:**
 - Memory Slave: Implements a AXI4 Interface Block Memory Generator Core in Memory Slave mode

- Peripheral Slave: Implements a AXI4 Interface Block Memory Generator Core in Peripheral Slave mode
- **ID Width Configurations:**
 - ID Width: When enabled supports AWID/BID/ARID/RID generation, ID Width can be configured from 1 to 16 bits

Customizing the Core with IP Integrator

Figure 4-8 shows the Block Memory Generator in IP Integrator with default options.

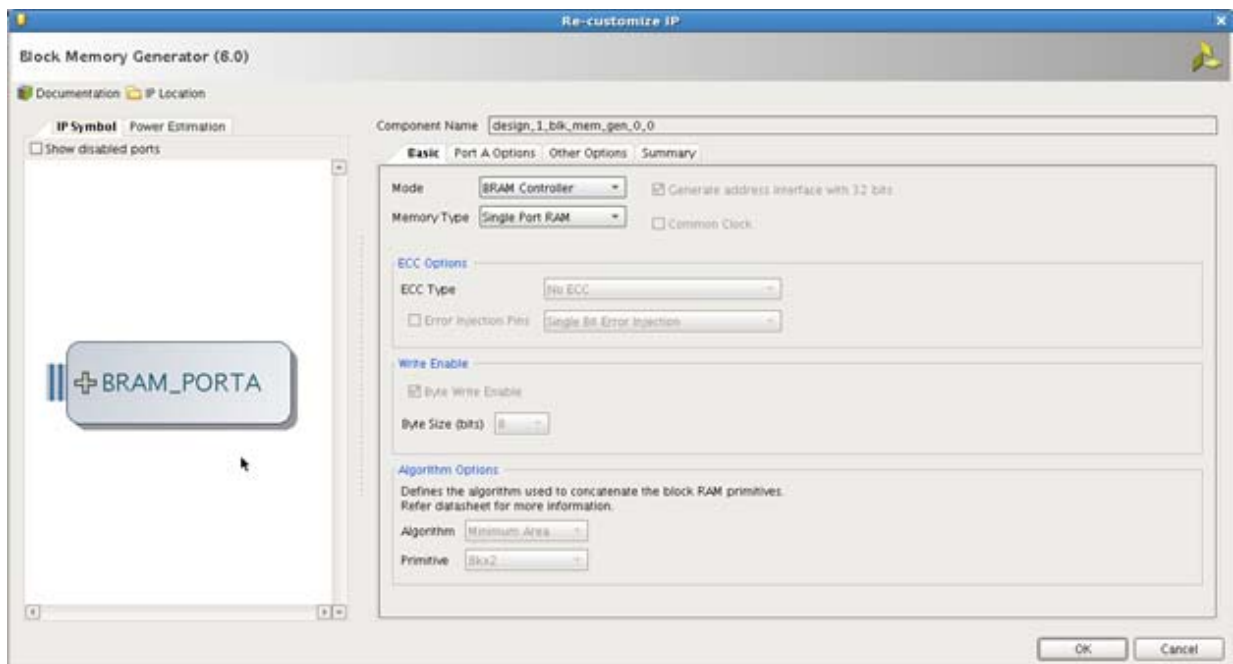

Figure 4-8: Customizing using IP Integrator

- **Mode:** The mode in which the Block Memory Generator is used in the IP Integrator. There are two modes available when using IP Integrator, and the default is **BRAM Controller**.
 - BRAM Controller Mode: This mode is selected when the Block Memory Generator is connected to either an AXI BRAM Controller or a Local Memory Bus Interface controller.
 - Stand Alone Mode: select this mode for connecting to all other devices.
- **Memory Type:** In the BRAM Controller mode, the Memory Type options are **Single Port RAM** or **True Dual Port RAM**.

Mode and memory are the only options available. All other parameters are set during validation of the design through parameter propagation.

Output Generation

For details about files generated with the core, see "Generating IP Output Products" in the *Vivado Design Suite User Guide: Designing with IP* (UG896) [Ref 5].

Constraining the Core

There are no constraints associated with this core.

Simulation

This chapter contains information about simulating in the Vivado® Design Suite environment. For details, see the *Vivado Design Suite User Guide: Logic Simulation* (UG900) [\[Ref 3\]](#).

Synthesis and Implementation

This chapter contains information about simulating and implementing in the Vivado® Design Suite environment. For details about synthesis and implementation, see “Synthesizing IP” and “Implementing IP” in the *Vivado Design Suite User Guide: Designing with IP* (UG896) [Ref 5].

Detailed Example Design

This chapter contains details about the Block Memory Generator example design using the Vivado Design Suite.

The Block Memory Generator example design includes the following:

- HDL wrapper which instantiates the Block Memory Generator netlist
- Block Memory Generator constraint file

The Block Memory Generator example design has been tested with Vivado Design Suite.

Test Bench

This chapter contains details about the Block Memory Generator test bench. The demonstration test bench is a straightforward VHDL file to exercise the example design and the core itself. The test bench consists of the following:

- Clock generators
- Address and data generator module
- Stimulus generator module
- Data checker
- Protocol checks for the AXI4 protocol

Figure 9-1 shows a block diagram of the demonstration test bench.

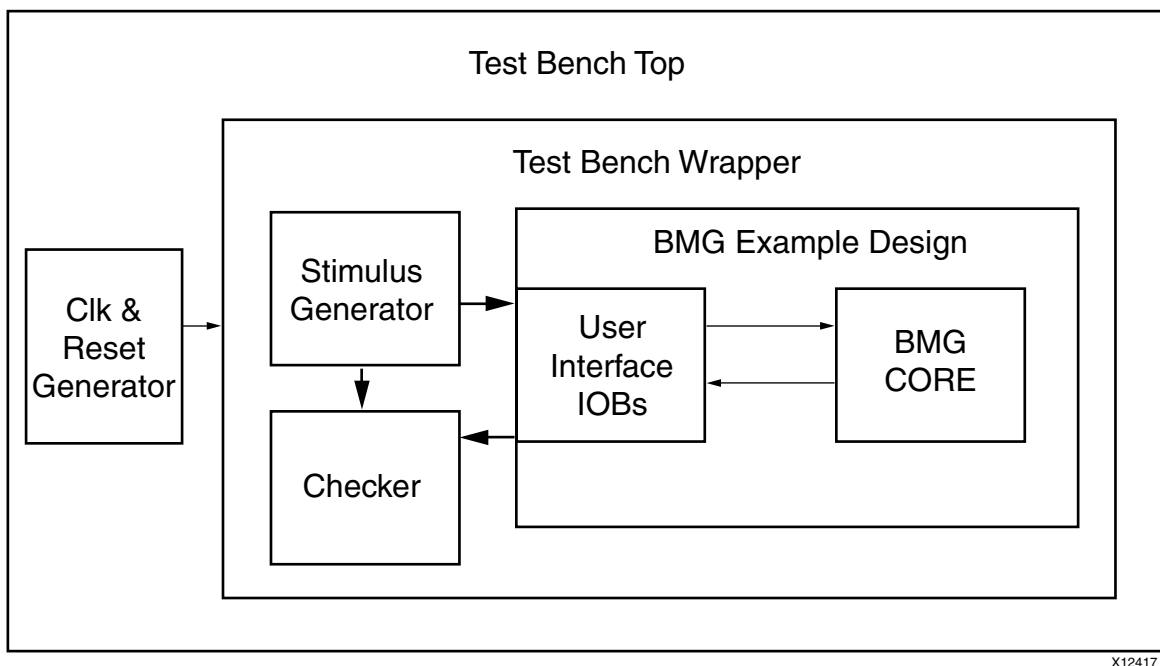

X12417

Figure 9-1: Test Bench Block Diagram

Core with Native Interface

The demonstration test bench in a core with a Native interface performs the following tasks:

- Generates input clock signals.
- Applies a reset to the example design. Address is generated in a linear, incremented format.
- Generates pseudo-random data and inputs this data to the Block Memory Generator data input port.
- Compares the outgoing data during reads with another pseudo-random generator with the same seed.
- Exercises the core with 256 write and read transactions.

Core with AXI4 Interface

The demonstration test bench in a core with an AXI4 interface performs the following tasks:

- Generates input clock signals.
- Applies a reset to the example design.
- Generates a stimulus only when incremented by burst. Narrow transactions are not exercised.
- Generates addresses in a linear, incremented format.
- Generates pseudo-random data for `wdata`.
- Determines the length (`awlen/arlen`) randomly.
- Compares RDATA during a read with another pseudo-random generator with the same seed as WDATA random data generator.
- Checks for AXI4 protocol violations with a basic AXI4 protocol checker.
- Exercises the core with 256 AXI4 write and read transactions.

Messages and Warnings

When the functional or timing simulation has completed successfully, the test bench displays the following message, and it is safe to ignore this message.

```
Failure: Test Completed Successfully
```

Verification, Compliance, and Interoperability

The Block Memory Generator core and the simulation models delivered with it are rigorously verified using advanced verification techniques, including a constrained random configuration generator and a cycle-accurate bus functional model.

Simulation

The Block Memory Generator has been tested with Xilinx Vivado Design Suite, Xilinx XSIM, Cadence Incisive Enterprise Simulator (IES), Synopsys VCS and VCS MX and Mentor Graphics Questa SIM.

Migrating and Updating

This appendix contains information about migrating a design from ISE® to the Vivado® Design Suite, and for upgrading to a more recent version of the IP core. For customers upgrading in the Vivado Design Suite, important details (where applicable) about any port changes and other impact to user logic are included.



TIP: For new designs, Xilinx recommends that you use the most recent version of the Block Memory Generator core for all block memory function requirements.

Migrating to the Vivado Design Suite

For information about migrating to the Vivado Design Suite, see *the ISE to Vivado Design Suite Migration Guide* (UG911) [Ref 6].

Upgrading in the Vivado Design Suite

Auto Upgrade Feature

The Block Memory Generator core has an auto upgrade feature for updating older versions of the Block Memory Generator core to the latest version. The auto upgrade feature can be seen by right clicking the already generated older version of Block Memory Generator core in the **Project IP** tab of the Vivado Design Suite. This feature can be initiated by selecting **Upgrade to Latest Version and Regenerate**. This option upgrades an older Block Memory Generator Core to the latest version. Any earlier version of Block Memory Generator core can be upgraded to v8.0.

Debugging

This appendix includes details about resources available on the Xilinx Support website and debugging tools.



TIP: *If the IP generation halts with an error, there may be a license issue. See [Licensing and Ordering Information in Chapter 1](#) for more details.*

Finding Help on Xilinx.com

To help in the design and debug process when using the Block Memory Generator, the [Xilinx Support web page](http://www.xilinx.com/support) (www.xilinx.com/support) contains key resources such as product documentation, release notes, answer records, information about known issues, and links for obtaining further product support.

Documentation

This product guide is the main document associated with the Block Memory Generator. This guide, along with documentation related to all products that aid in the design process, can be found on the Xilinx Support web page (www.xilinx.com/support) or by using the Xilinx Documentation Navigator.

Download the Xilinx Documentation Navigator from the Design Tools tab on the Downloads page (www.xilinx.com/download). For more information about this tool and the features available, open the online help after installation.

Answer Records

Answer Records include information about commonly encountered problems, helpful information on how to resolve these problems, and any known issues with a Xilinx product. Answer Records are created and maintained daily ensuring that users have access to the most accurate information available.

Answer Records can also be located by using the Search Support box on the main [Xilinx support web page](http://www.xilinx.com/support). To maximize your search results, use proper keywords such as

- Product name

- Tool message(s)
- Summary of the issue encountered

A filter search is available after results are returned to further target the results.

Master Answer Record for the Block Memory Generator

AR [50918](#)

Contacting Technical Support

Xilinx provides technical support at www.xilinx.com/support for this LogiCORE™ IP product when used as described in the product documentation. Xilinx cannot guarantee timing, functionality, or support of product if implemented in devices that are not defined in the documentation, if customized beyond that allowed in the product documentation, or if changes are made to any section of the design labeled DO NOT MODIFY.

Xilinx provides premier technical support for customers encountering issues that require additional assistance. To contact Xilinx Technical Support:

1. Navigate to www.xilinx.com/support.
2. Open a WebCase by selecting the [WebCase](#) link located under Additional Resources.

When opening a WebCase, include:

- Target FPGA including package and speed grade.
- All applicable Xilinx Design Tools and simulator software versions.
- Additional files based on the specific issue might also be required. See the relevant sections in this debug guide for guidelines about which file(s) to include with the WebCase.

Note: Access to WebCase is not available in all cases. Login to the WebCase tool to see your specific support options.

Debug Tools

Vivado Lab Tools

Vivado® lab tools insert logic analyzer and virtual I/O cores directly into your design. Vivado lab tools allow you to set trigger conditions to capture application and integrated block port signals in hardware. Captured signals can then be analyzed. This feature represents the functionality in the Vivado IDE that is used for logic debugging and validation of a design running in Xilinx FPGA devices in hardware.

The Vivado logic analyzer is used to interact with the logic debug LogiCORE IP cores, including:

- ILA 2.0 (and later versions)
- VIO 2.0 (and later versions)

Simulation Debug

For details about simulating a design in the Vivado Design Suite, see the *Vivado Logic Simulation User Guide* (UG900) [Ref 3].

Hardware Debug

Hardware issues can range from link bring-up to problems seen after hours of testing. This section provides debug steps for common issues.

General Checks

Ensure that all the timing constraints for the core were properly incorporated from the example design and that all constraints were met during implementation.

- Does it work in post-place and route timing simulation? If problems are seen in hardware but not in timing simulation, this could indicate a PCB issue. Ensure that all clock sources are active and clean.
- If using MMCMs in the design, ensure that all MMCMs have obtained lock by monitoring the `LOCKED` port.
- If your outputs go to 0, check your licensing.

Native Block Memory Generator Supplemental Information

The following sections provide additional information about working with the Block Memory Generator core.

- [Low Power Designs](#): Provides information on the Low Power algorithm and methods that can be followed by the user to optimize power consumption in block RAM designs.
- [Native Block Memory Generator SIM Parameters](#): Defines the SIM parameters used to specify the core configuration.
- [Output Register Configurations](#): Provides information optional output registers used to improve core performance.

Low Power Designs

The Block Memory Generator core also supports a Low Power implementation algorithm. When this option is selected, the configuration of the core is optimized to minimize dynamic power consumption. This contrasts with the Minimum Area algorithm, which optimizes the core implementation with the sole purpose of minimizing resource utilization.

The Low Power algorithm reduces power through the following mechanisms:

- Minimizing the number of block RAMs enabled for a Write or Read operation for a given memory size.
- Unlike the Minimum Area algorithm, smaller block RAM blocks are not grouped to form larger blocks in the Low Power algorithm. For example, two 18K block RAMs are not combined to form a 36K block RAM in Virtex-7 devices.
- The “Always Enabled” option is not available to the user for the Port A and Port B enable pins. This prevents the block RAMs from being enabled at all times.
- The NO_CHANGE mode is set as the default operating mode.

XPE is a pre-implementation power estimation tool appropriate for estimating power requirements in the early stages of a design. For more accurate power consumption estimates and power analysis, the Xilinx Power Analyzer tool (XPA) available in Vivado tools can be run on designs after place and route.

Power data shown in the following tables was collected assuming a 50% toggle rate and 50% Write rate. A frequency of 300 MHz was specified for Virtex-7 devices.

Note: Always use the latest version of each target architecture XPE spreadsheet to get the most accurate estimate.

Besides using the Low Power algorithm, the following design considerations are recommended for power optimizations:

- The Low Power algorithm disables the “Always Enabled” option for the Port A and Port B enable pins, and the user is forced to have these pins at the output (the **Use EN[A|B] Pin** option). These pins must not be permanently tied to ‘1’ if it is desired that power be conserved. Each port’s enable pin must be asserted high only when that port of the block RAM needs to be accessed.
- Use of output registers improves performance, but also increases power consumption. Even if used in the design, the output registers should be disabled when the block RAMs are not being accessed.
- The user can choose the operating mode even in the Low Power algorithm based upon design requirements; however it is recommended that the default operating mode of the Low Power algorithm (NO_CHANGE mode) be used. This mode results in lower power consumption as compared to the WRITE_FIRST and READ_FIRST modes.

Native Block Memory Generator SIM Parameters

Table D-1 defines the SIM parameters used to specify the configuration of the core. These parameters are only used to manually instantiate the core in HDL, calling the CORE Generator dynamically.

Table D-1: Native Interface SIM Parameters

	SIM Parameter	Type	Values	Description
1	C_FAMILY	String	virtex7 , kintex7, artix7, zynq7000	Target device family
2	C_XDEVICEFAMILY	String	virtex7 , kintex7, artix7, zynq7000	Finest resolution target family derived from the parent C_FAMILY
3	C_ELABORATION_DIR	String		Elaboration Directory
4	C_USE_BRAM_BLOCK	Integer	0: Standalone 1: BRAM Controller	Used in IPI Mode only. Defines whether the BMG works in conjunction with the BRAM Controller or if the core works in standalone IP mode.
5	C_ENABLE_32BIT_ADDRESS	Integer	0: Address interface defined by memory depth 1: Generates 32-bit address interface	Used in IPI Mode only. Defines whether the BMG core generates 32-bit address interface for BRAM Controller mode.

Table D-1: Native Interface SIM Parameters (Cont'd)

	SIM Parameter	Type	Values	Description
6	C_MEM_TYPE	Integer	0: Single Port RAM 1: Simple Dual Port RAM 2: True Dual Port RAM 3: Single Port ROM 4: Dual Port ROM	Type of memory
7	C_ALGORITHM	Integer	0 (selectable primitive), 1 (minimum area), 2 (low power)	Type of algorithm
8	C_PRIM_TYPE	Integer	0 (1-bit wide) 1 (2-bit wide) 2 (4-bit wide) 3 (9-bit wide) 4 (18-bit wide) 5 (36-bit wide) 6 (72-bit wide, single-port only)	If fixed primitive algorithm is chosen, determines which type of primitive to use to build memory
9	C_BYTE_SIZE	Integer	9, 8	Defines size of a byte: 9 bits or 8 bits
10	C_SIM_COLLISION_CHECK	String	NONE, GENERATE_X_ONLY, ALL, WARNINGS_ONLY	Defines warning collision checks in structural/unisim simulation model
11	C_COMMON_CLOCK	Integer	0, 1	Determines whether to optimize behavioral models for Read/Write accesses and collision checks by assuming clocks are synchronous. It is recommended to set this option to 0 when both the clocks are not synchronous, in order to have the models function properly.
12	C_DISABLE_WARN_BHV_COLL	Integer	0, 1	Disables the behavioral model from generating warnings due to Read-Write collisions
13	C_DISABLE_WARN_BHV_RANGE	Integer	0, 1	Disables the behavioral model from generating warnings due to address out of range
14	C_LOAD_INIT_FILE	Integer	0, 1	Defined whether to load initialization file
15	C_INIT_FILE_NAME	String	""	Name of initialization file (COE format)
16	C_USE_DEFAULT_DATA	Integer	0, 1	Determines whether to use default data for the memory

Table D-1: Native Interface SIM Parameters (Cont'd)

	SIM Parameter	Type	Values	Description
17	C_DEFAULT_DATA	String	"0"	Defines a default data for the memory
18	C_HAS_MEM_OUTPUT_REGS_A	Integer	0, 1	Determines whether port A has a register stage added at the output of the memory latch
19	C_HAS_MEM_OUTPUT_REGS_B	Integer	0,1	Determines whether port B has a register stage added at the output of the memory latch
20	C_HAS_MUX_OUTPUT_REGS_A	Integer	0,1	Determines whether port A has a register stage added at the output of the memory core
21	C_HAS_MUX_OUTPUT_REGS_B	Integer	0,1	Determines whether port B has a register stage added at the output of the memory core
22	C_MUX_PIPELINE_STAGES	Integer	0,1,2,3	Determines the number of pipeline stages within the MUX for both port A and port B
23	C_WRITE_WIDTH_A	Integer	1 to 4608	Defines width of Write port A
24	C_READ_WIDTH_A	Integer	1 to 4608	Defines width of Read port A
25	C_WRITE_DEPTH_A	Integer	2 to 128 k ⁽¹⁾	Defines depth of Write port A
26	C_READ_DEPTH_A	Integer	2 to 128 k ⁽¹⁾	Defines depth of Read port A
27	C_ADDRA_WIDTH	Integer	1 to 24	Defines the width of address A
28	C_WRITE_MODE_A	String	Write_First, Read_first, No_change	Defines the Write mode for port A
29	C_HAS_ENA	Integer	0, 1	Determines whether port A has an enable pin
30	C_HAS_REGCEA	Integer	0, 1	Determines whether port A has an enable pin for its output register
31	C_HAS_RSTA	Integer	0, 1	Determines whether port A has reset pin
32	C_INITA_VAL	String	"0"	Defines initialization/power-on value for port A output
33	C_USE_BYTE_WEA	Integer	0, 1	Determines whether byte-Write feature is used on port A For True Dual Port configurations, this value is the same as C_USE_BYTE_WEB, since there is only a single byte Write enable option provided
34	C_WEA_WIDTH	Integer	1 to 512	Defines width of WEA pin for port A
35	C_WRITE_WIDTH_B	Integer	1 to 4608	Defines width of Write port B

Table D-1: Native Interface SIM Parameters (Cont'd)

	SIM Parameter	Type	Values	Description
36	C_READ_WIDTH_B	Integer	1 to 4608	Defines width of Read port B
37	C_WRITE_DEPTH_B	Integer	2 to 128 k	Defines depth of Write port B
38	C_READ_DEPTH_B	Integer	2 to 128 k	Defines depth of Read port B
39	C_ADDRB_WIDTH	Integer	1 to 24	Defines the width of address B
40	C_WRITE_MODE_B	String	Write_First, Read_first, No_change	Defines the Write mode for port B
41	C_HAS_ENB	Integer	0, 1	Determines whether port B has an enable pin
42	C_HAS_REGCEB	Integer	0, 1	Determines whether port B has an enable pin for its output register
43	C_HAS_RSTB	Integer	0, 1	Determines whether port B has reset pin
44	C_INITB_VAL	String	"..."	Defines initialization/power-on value for port B output
45	C_USE_BYTE_WEB	Integer	0, 1	Determines whether byte-Write feature is used on port B This value is the same as C_USE_BYTE_WEA, since there is only a single byte Write enable provided
46	C_WEB_WIDTH	Integer	1 to 512	Defines width of web pin for port B
47	C_USE_ECC	Integer	0,1	Determines ECC options: • 0 = No ECC • 1 = ECC
48	C_RST_TYPE	String	"SYNC"	Type of Reset
49	C_RST_PRIORITY_A	String	(["CE", "SR"] : "CE")	In the absence of output registers, this selects the priority between the RAM ENA and the rsta pin. When using output registers, this selects the priority between REGCEA and the rsta pin.

Table D-1: Native Interface SIM Parameters (Cont'd)

	SIM Parameter	Type	Values	Description
50	C_RSTRAM_A11	Integer	([0,1] : 1)	<p>If the value of this generic is 1, both the memory latch and the embedded primitive output register of Port A are reset. If this value is 0, only the embedded output register of the primitive is reset (the memory latch is not reset).</p> <p>Setting this option to 1 results in the output reset value being asserted for two clock cycles.</p>
51	C_RST_PRIORITY_B	String	(["CE", "SR"] : "CE")	<p>In the absence of output registers, this selects the priority between the RAM ENB and the rstb pin. When using output registers, this selects the priority between REGCEB and the rstb pin.</p>
52	C_RSTRAM_B	Integer	([0,1] : 1)	<p>If the value of this generic is 1, both the memory latch and the embedded primitive output register of Port B are reset. If this value is 0, only the embedded output register of the primitive is reset (the memory latch is not reset).</p> <p>Setting this option to 1 results in the output reset value being asserted for two clock cycles.</p>
53	C_HAS_INJECTERR	Integer	([0,1,2,3] : 0)	<p>Determines the type of error injection:</p> <ul style="list-style-type: none"> • 0 = No Error Injection • 1 = Single-Bit Error Injection Only • 2 = Double-Bit Error Injection Only • 3 = Both Single- and Double-Bit Error Injection
54	C_USE_SOFTECC	Integer	0,1	<p>Determines Soft ECC options:</p> <ul style="list-style-type: none"> • 0 = No Soft ECC • 1 = Soft ECC
55	C_HAS_SOFTECC_INPUT_REGS_A	Integer	0,1	<p>Registers the input ports in the design when Soft ECC is enabled:</p> <ul style="list-style-type: none"> • 0 = Registers not enabled • 1 = Registers enabled

Table D-1: Native Interface SIM Parameters (Cont'd)

	SIM Parameter	Type	Values	Description
56	C_HAS_SOFTECC_OUTPUT_REGS_B	Integer	0,1	Registers the input ports in the design when Soft ECC is enabled: <ul style="list-style-type: none"> • 0 = Registers not enabled • 1 = Registers enabled
57	C_INIT_FILE	String		Name of the Initialization file (MEM format)
58	C_CTRL_ECC_ALGO	String		Carries the ECC algorithm information from the master to which Block Memory Generator is connected in IP Integrator.

1. Depth is restricted based on Write width.

AXI4 Interface Block Memory Generator SIM Parameters

Table D-2: AXI4 Interface SIM Parameters

	SIM Parameter	Type	Values	Description
1	C_FAMILY	String	"7 series"	Target device family.
2	C_XDEVICEFAMILY	String	"7 series"	Finest resolution target family.
3	C_ELABORATION_DIR	String		Elaboration Directory.
4	C_INTERFACE_TYPE	Integer	1: AXI4	Determines the type of interface selected.
5	C_AXI_TYPE	Integer	0: AXI4_Lite 1: AXI4_Full	Determines the type of the AXI4 interface.
6	C_AXI_SLAVE_TYPE	Integer	0: Memory Slave 1: Peripheral Slave	Determines the type of the AXI4 Slave interface.
7	C_HAS_AXI_ID	Integer	0: Core does not use AXI4 ID 1: Core uses AXI4 ID	Determines whether the AXI4 interface supports AXI4 ID.
8	C_AXI_ID_WIDTH	Integer	1 to 16	Defines the AXI4 ID value.
9	C_MEM_TYPE	Integer	1: Simple Dual Port RAM	Type of memory.
10	C_ALGORITHM	Integer	0 (selectable primitive), 1 (minimum area), 2 (low power)	Type of algorithm.
11	C_PRIM_TYPE	Integer	4 (18-bit wide) 5 (36-bit wide) 6 (72-bit wide)	If fixed primitive algorithm is chosen, determines which type of primitive to use to build memory.
12	C_BYTE_SIZE	Integer	8	Defines size of a byte: 8 bits.

Table D-2: AXI4 Interface SIM Parameters (Cont'd)

	SIM Parameter	Type	Values	Description
13	C_COMMON_CLOCK	Integer	1	Determines whether to optimize behavioral models for Read/Write accesses and collision checks by assuming clocks are synchronous.
14	C_DISABLE_WARN_BHV_COLL	Integer	0, 1	Disables the behavioral model from generating warnings due to Read Write collisions.
15	C_DISABLE_WARN_BHV_RANGE	Integer	0, 1	Disables the behavioral model from generating warnings due to address out of range.
16	C_LOAD_INIT_FILE	Integer	0, 1	Defined whether to load initialization File.
17	C_INIT_FILE_NAME	String	""	Name of initialization file (COE format).
18	C_USE_DEFAULT_DATA	Integer	0, 1	Determines whether to use default data for the memory.
19	C_DEFAULT_DATA	String	0	Defines a default data for the Memory.
20	C_HAS_MEM_OUTPUT_REGS_A	Integer	0	Determines whether port A has a register stage added at the output of the memory latch.
21	C_HAS_MEM_OUTPUT_REGS_B	Integer	0	Determines whether port B has a register stage added at the output of the memory latch.
22	C_HAS_MUX_OUTPUT_REGS_A	Integer	0	Determines whether port A has a register stage added at the output of the memory core.
23	C_HAS_MUX_OUTPUT_REGS_B	Integer	0	Determines whether port B has a register stage added at the output of the memory core.
24	C_MUX_PIPELINE_STAGES	Integer	0	Determines the number of pipeline stages within the MUX for both port A and port B.
25	C_WRITE_WIDTH_A	Integer	32 to 256	Defines width of Write port A.
26	C_READ_WIDTH_A	Integer	32 to 256	Defines width of Read port A.
27	C_WRITE_DEPTH_A	Integer	1 to 128 k	Defines depth of Write port A.
28	C_READ_DEPTH_A	Integer	1 to 128 k	Defines depth of Read port A.
29	C_ADDRA_WIDTH	Integer	1 to 32	Defines the width of address A.
30	C_WRITE_MODE_A	String	Read_first	Defines the Write mode for port A.
31	C_HAS_ENA	Integer	1	Determines whether port A has an enable pin.

Table D-2: AXI4 Interface SIM Parameters (Cont'd)

	SIM Parameter	Type	Values	Description
32	C_HAS_REGCEA	Integer	0	Determines whether port A has an enable pin for its output register.
33	C_HAS_RSTA	Integer	0	Determines whether port A has reset pin.
34	C_INITA_VAL	String	"0"	Defines initialization/power-on value for port A output.
35	C_USE_BYTE_WEA	Integer	1	Determines whether byte-Write feature is used on port A.
36	C_WEA_WIDTH	Integer	1 to 128	Defines width of wea pin for port A.
37	C_WRITE_WIDTH_B	Integer	32 to 256	Defines width of Write port B.
38	C_READ_WIDTH_B	Integer	32 to 256	Defines width of Read port B.
39	C_WRITE_DEPTH_B	Integer	1 to 128 k	Defines depth of Write port B.
40	C_READ_DEPTH_B	Integer	1 to 128 k	Defines depth of Read port B.
41	C_ADDRB_WIDTH	Integer	1 to 32	Defines the width of address B.
42	C_WRITE_MODE_B	String	Read_first,	Defines the Write mode for port B.
43	C_HAS_ENB	Integer	1	Determines whether port B has an enable pin.
44	C_HAS_REGCEB	Integer	0	Determines whether port B has an enable pin for its output register.
45	C_HAS_RSTB	Integer	1	Determines whether port B has reset pin.
46	C_INITB_VAL	String	"0"	Defines initialization/power-on value for port B output.
47	C_USE_BYTE_WEB	Integer	1	Determines whether byte-Write feature is used on port B. This value is the same as C_USE_BYTE_WEA, since there is only a single byte Write enable provided.
48	C_WEB_WIDTH	Integer	1 to 128	Defines width of web pin for port B.
49	C_USE_ECC	Integer	0	Determines ECC options: <ul style="list-style-type: none"> • 0 = No ECC • 1 = ECC
50	C_RST_TYPE	String	"SYNC"	Type of Reset

Table D-2: AXI4 Interface SIM Parameters (Cont'd)

	SIM Parameter	Type	Values	Description
51	C_RST_PRIORITY_A	String	"CE"	In the absence of output registers, this selects the priority between the RAM ENA and the rsta pin. When using output registers, this selects the priority between REGCEA and the rsta pin.
52	C_RSTRAM_A	Integer	0	If the value of this generic is 1, both the memory latch and the embedded primitive output register of Port A are reset. If this value is 0, only the embedded output register of the primitive is reset (the memory latch is not reset). Setting this option to 1 results in the output reset value being asserted for two clock cycles.
53	C_RST_PRIORITY_B	String	"CE"	In the absence of output registers, this selects the priority between the RAM ENB and the rstb pin. When using output registers, this selects the priority between REGCEB and the rstb pin.
54	C_RSTRAM_B	Integer	0	If the value of this generic is 1, both the memory latch and the embedded primitive output register of Port B are reset. If this value is 0, only the embedded output register of the primitive is reset (the memory latch is not reset). Setting this option to 1 results in the output reset value being asserted for two clock cycles.
55	C_HAS_INJECTERR	Integer	0	Determines the type of error injection: <ul style="list-style-type: none"> • 0 = No Error Injection • 1 = Single-Bit Error Injection Only • 2 = Double-Bit Error Injection Only • 3 = Both Single- and Double-Bit Error Injection
56	C_USE_SOFTECC	Integer	0	Determines Soft ECC options: <ul style="list-style-type: none"> • 0 = No Soft ECC • 1 = Soft ECC

Table D-2: AXI4 Interface SIM Parameters (Cont'd)

	SIM Parameter	Type	Values	Description
57	C_HAS_SOFTECC_INPUT_REGS_A	Integer	0	Registers the input ports in the design when Soft ECC is enabled: <ul style="list-style-type: none"> • 0 = Registers not enabled • 1 = Registers enable
58	C_HAS_SOFTECC_OUTPUT_REGS_B	Integer	0	Registers the input ports in the design when Soft ECC is enabled: <ul style="list-style-type: none"> • 0 = Registers not enabled • 1 = Registers enabled
59	C_SIM_COLLISION_CHECK	String	NONE, GENERATE_X_ONLY, ALL, WARNINGS_ONLY	Defines warning collision checks in structural/UniSim simulation model.

Output Register Configurations

The Block Memory Generator core provides optional output registers that can be selected for port A and port B separately, and that may improve the performance of the core.

Figure D-1 shows the Optional Output Registers section of the Block Memory Generator GUI.

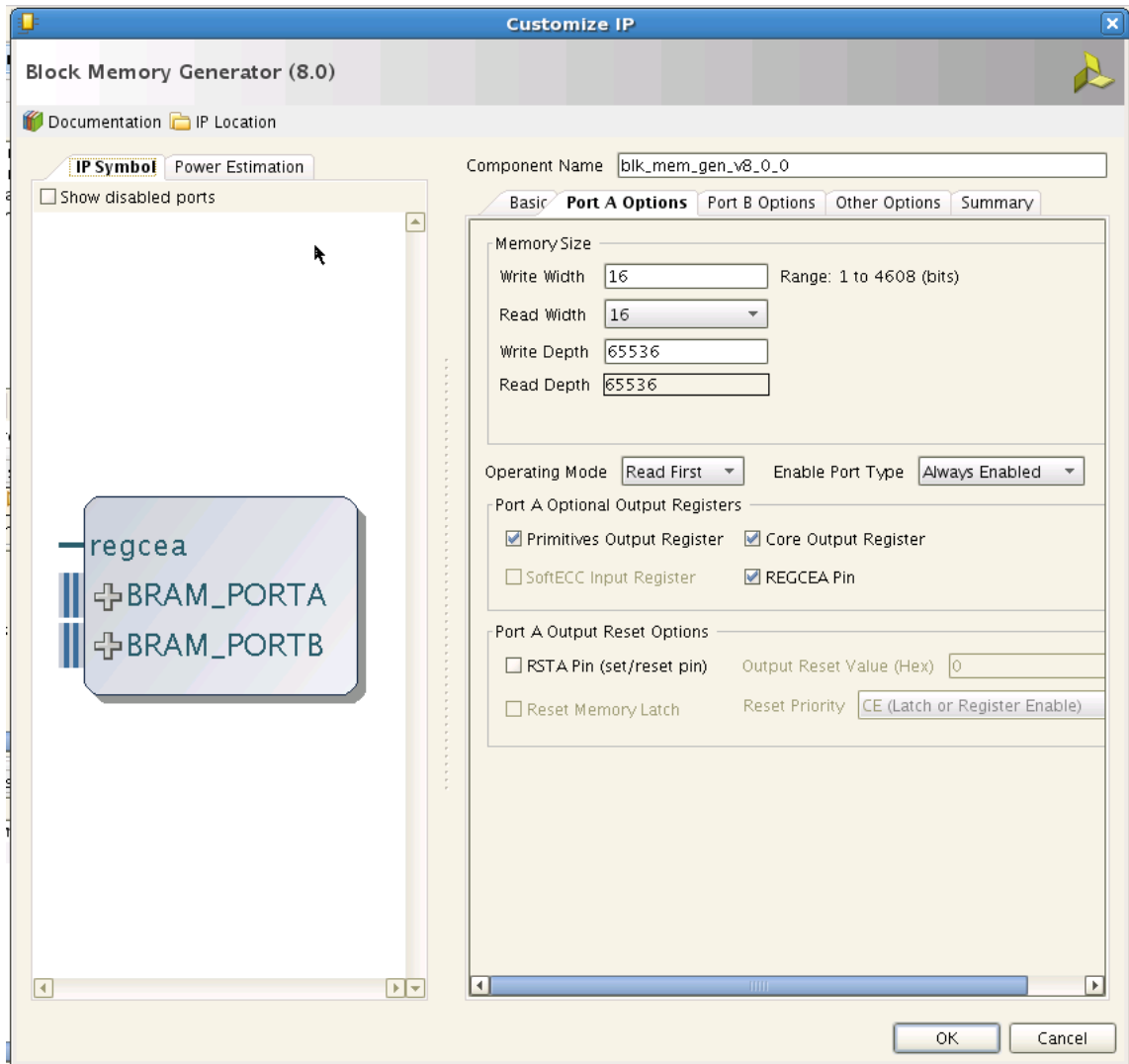

Figure D-1: Optional Output Registers Section

To tailor register options, two selections for port A and two selections for port B are provided on Port A/B Options of the Vivado IP Catalog GUI in the Optional [A|B] Output Registers section. The embedded output registers for the corresponding port(s) are enabled when Register Port [A|B] Output of Memory Primitives is selected. Similarly, registers at the output of the core for the corresponding port(s) are enabled by selecting Register Port [A|B] Output of Memory Core. Figure D-2 through Figure D-6 illustrate the output register configurations.

When only Register Port [A|B] Output of Memory Primitives and the corresponding Use RST[A|B] Pin are selected, the special reset behavior (option to reset the memory latch, in addition to the primitive output register) becomes available. For more information on this reset behavior, see [Special Reset Behavior in Chapter 3](#).

Memory with Primitive and Core Output Registers

With both Register Port [A|B] Output of Memory Primitives and the corresponding Register Port [A|B] Output of Memory Core selected, a memory core is generated with the embedded output registers and a register on the output of the core for the selected port(s), as shown in Figure D-2. This configuration may provide improved performance for building large memory constructs.

Port A	or	Port B
<input checked="" type="checkbox"/> Register Port A Output of Memory Primitives		<input checked="" type="checkbox"/> Register Port B Output of Memory Primitives
<input checked="" type="checkbox"/> Register Port A Output of Memory Core		<input checked="" type="checkbox"/> Register Port B Output of Memory Core

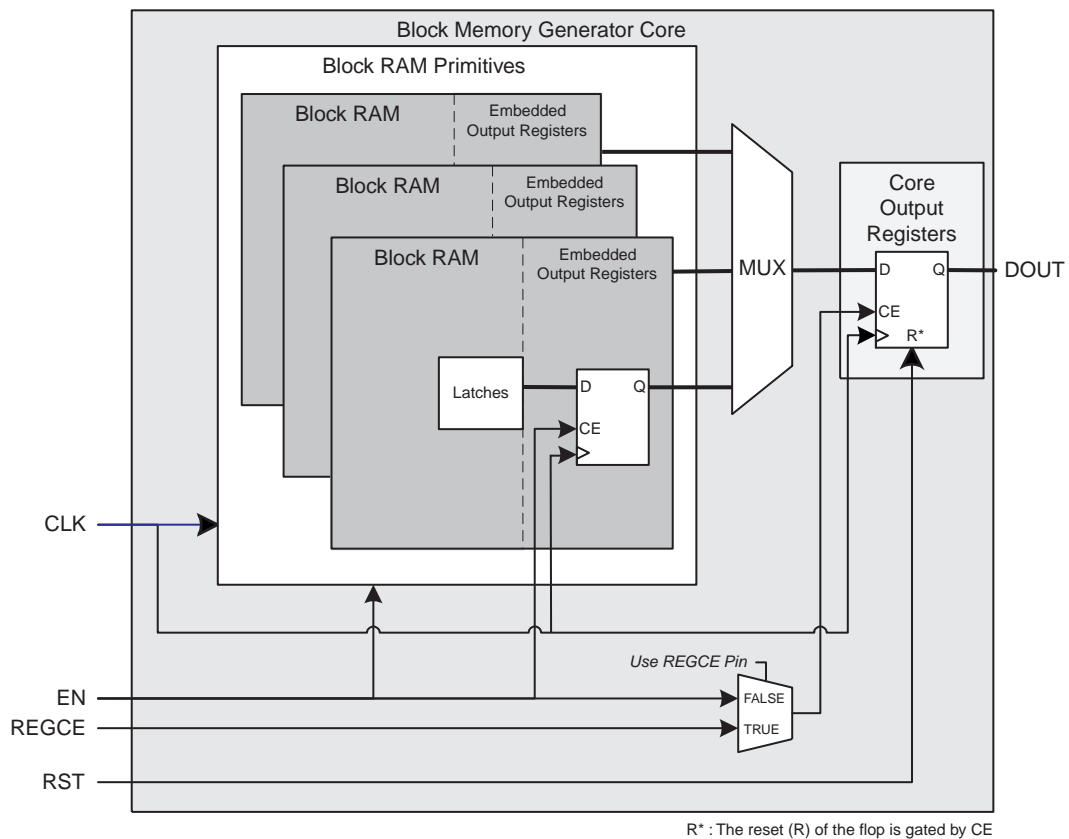

Figure D-2: Block Memory Generated with Register Port [A|B] Output of Memory Primitives and Register Port [A|B] Output of Memory Core Enabled

Memory with Primitive Output Registers and without Special Reset Behavior Option

If Use rsta Pin (set/reset pin) or Use rstb Pin (set/reset pin) is selected, and the special reset behavior (to reset the memory latch besides the primitive output register) is not selected, then the input reset signal is only connected to the RSTREG pin of the block RAM primitive, as illustrated in Figure D-3.

Port A	or	Port B
<input checked="" type="checkbox"/> Register Port A Output of Memory Primitives		<input checked="" type="checkbox"/> Register Port B Output of Memory Primitives
<input type="checkbox"/> Register Port A Output of Memory Core		<input type="checkbox"/> Register Port B Output of Memory Core
<input checked="" type="checkbox"/> Use rsta Pin (set/reset pin)		<input checked="" type="checkbox"/> Use rstb Pin (set/reset pin)
<input type="checkbox"/> Reset Memory Latch		<input type="checkbox"/> Reset Memory Latch

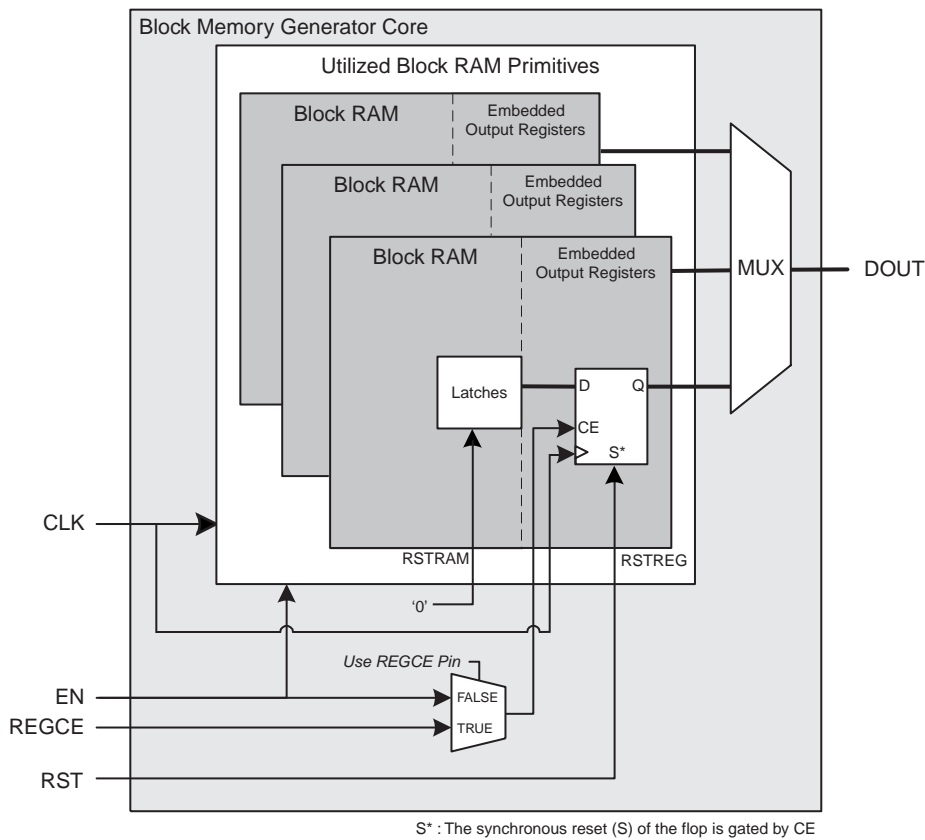

Figure D-3: Block Memory Generated with Register Port [A|B] Output of Memory Primitives Enabled and without Special Reset Behavior

Memory with Primitive Output Registers and with Special Reset Behavior Option

When Register Port [A|B] Output of Memory Primitives, Use rsta Pin (set/reset pin) or Use rstb Pin (set/reset pin), and the special reset behavior (to reset the memory latch besides the primitive output register) are selected, then the input reset signal is connected to both the RSTRAM and RSTREG pins of the block RAM primitive, as illustrated in Figure D-4.

Port A	or	Port B
<input checked="" type="checkbox"/> Register Port A Output of Memory Primitives		<input checked="" type="checkbox"/> Register Port B Output of Memory Primitives
<input type="checkbox"/> Register Port A Output of Memory Core		<input type="checkbox"/> Register Port B Output of Memory Core
<input checked="" type="checkbox"/> Use rsta Pin (set/reset pin)		<input checked="" type="checkbox"/> Use rstb Pin (set/reset pin)
<input checked="" type="checkbox"/> Reset Memory Latch		<input checked="" type="checkbox"/> Reset Memory Latch

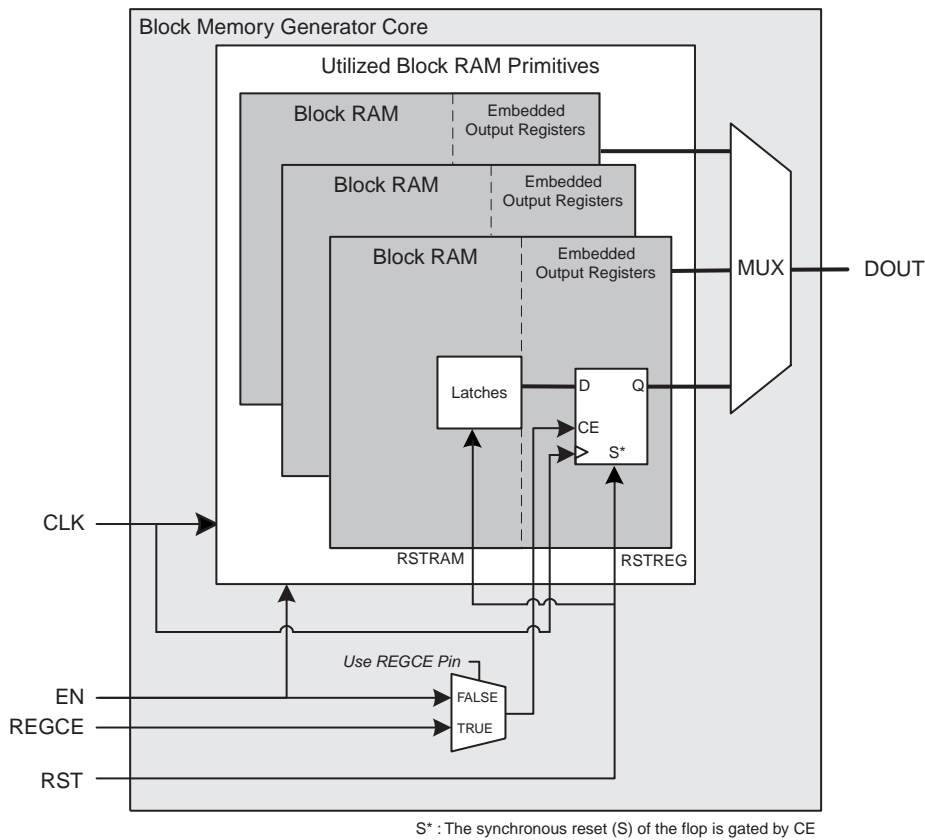

Figure D-4: Block Memory Generated with Register Port [A|B] Output of Memory Primitives Enabled and with Special Reset Behavior

Memory with Core Output Registers

When only Register Port [A|B] Output of Memory Core is selected, the device's embedded registers are disabled for the selected ports in the generated core, as shown in Figure D-5.

Port A	or	Port B
<input type="checkbox"/> Register Port A Output of Memory Primitives		<input type="checkbox"/> Register Port B Output of Memory Primitives
<input checked="" type="checkbox"/> Register Port A Output of Memory Core		<input checked="" type="checkbox"/> Register Port B Output of Memory Core

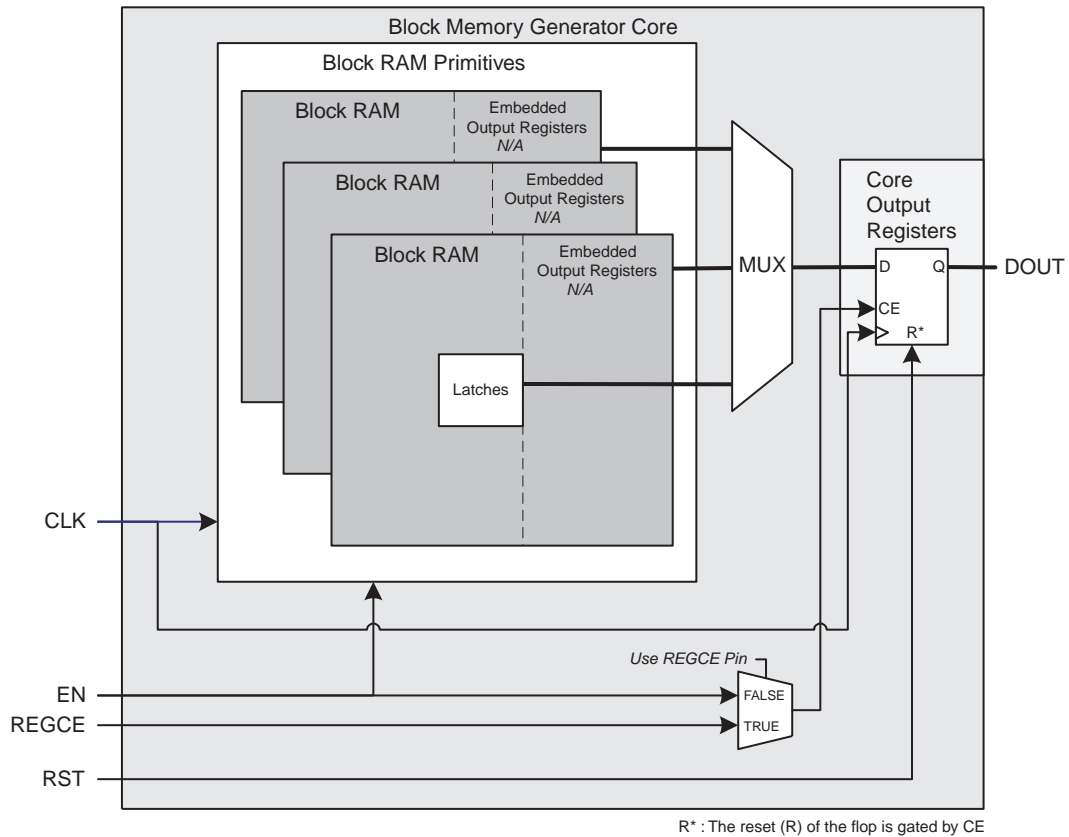

Figure D-5: Block Memory Generated with Register Port [A|B] Output of Memory Core Enabled

Memory with No Output Registers

If neither of the output registers is selected for ports A or B, output of the memory primitives is driven directly from the RAM primitive latches. In this configuration, as shown in [Figure D-6](#), there are no additional clock cycles of latency, but the clock-to-out delay for a Read operation can impact design performance.

Port A	or	Port B
<input type="checkbox"/> Register Port A Output of Memory Primitives		<input type="checkbox"/> Register Port B Output of Memory Primitives
<input type="checkbox"/> Register Port A Output of Memory Core		<input type="checkbox"/> Register Port B Output of Memory Core

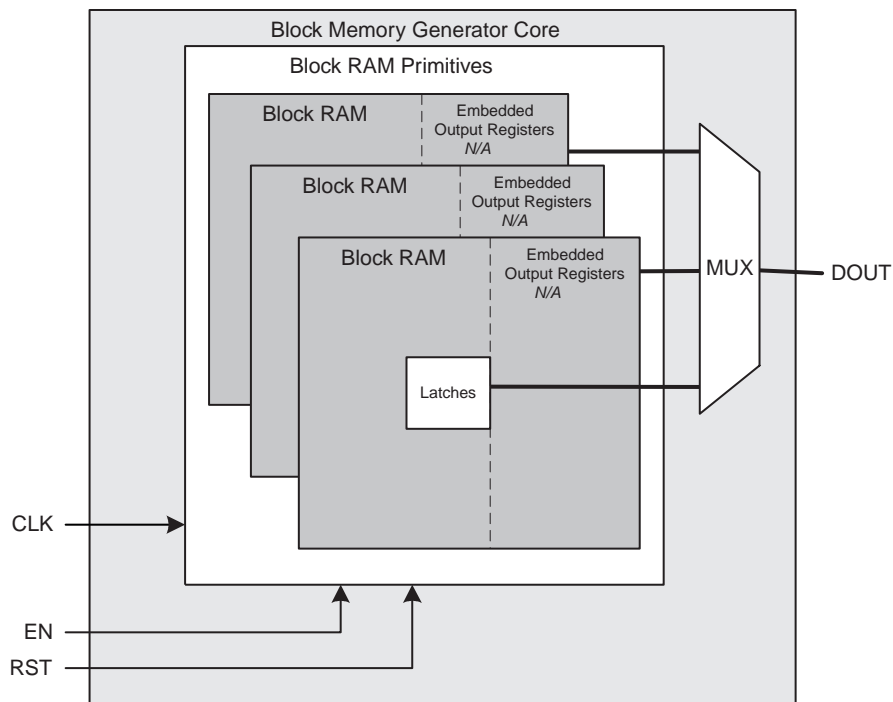

Figure D-6: Block Memory Generated with No Output Registers Enabled

Additional Resources

Xilinx Resources

For support resources such as Answers, Documentation, Downloads, and Forums, see the Xilinx Support website at:

www.xilinx.com/support.

For a glossary of technical terms used in Xilinx documentation, see:

www.xilinx.com/company/terms.htm.

References

These documents provide supplemental material useful with this product guide:

1. *AMBA AXI4-Stream Protocol Specification*
2. *Xilinx AXI Reference Guide* ([UG761](#))
3. *Vivado Design Suite User Guide: Logic Simulation* ([UG900](#))
4. *Vivado Design Suite User Guide: Implementation* ([UG904](#))
5. *Vivado Design Suite User Guide: Designing with IP* ([UG896](#))
6. *ISE to Vivado Design Suite Migration Guide* ([UG911](#))
7. *Vivado Design Suite User Guide: Programming and Debugging* ([UG908](#))
8. *Vivado Design Suite User Guide: Getting Started* ([UG910](#))

Revision History

The following table shows the revision history for this document.

Date	Version	Description of Revisions
7/25/12	1.0	Initial Xilinx release. Added support for Vivado Design Suite. This document replaces DS512, <i>Block Memory Generator Data Sheet</i> , and XAPP917, <i>Block Memory Generator Migration Guide</i> .
10/16/12	2.0	Updated core to v7.3, ISE Design Suite to 14.3 and Vivado Design Suite to 2012.3. Added the C_USE_BRAM_BLOCK and C_ENABLE_32BIT_ADDRESS parameters.
12/18/12	2.1	Updated ISE Design Suite to 14.4 and Vivado Design Suite to 2012.4. Added Virtex-7 device performance data in Single Primitive in Chapter 2 .
03/20/13	3.0	Updated core to v8.0. Removed support for ISE Design Suite. Removed support for Virtex-6, Virtex-5 and Spartan-3 family devices.
10/02/13	8.0	<ul style="list-style-type: none"> Document revision number advanced to 8.0 to align with core version number. Maximum width of memory structures changed to 4608. Added details about memory configuration options in Table 1-4. Added information about Read Data and Read Enable Latency in Chapter 3. Added Detailed Example Design and Test Bench chapters.

Notice of Disclaimer

The information disclosed to you hereunder (the "Materials") is provided solely for the selection and use of Xilinx products. To the maximum extent permitted by applicable law: (1) Materials are made available "AS IS" and with all faults, Xilinx hereby DISCLAIMS ALL WARRANTIES AND CONDITIONS, EXPRESS, IMPLIED, OR STATUTORY, INCLUDING BUT NOT LIMITED TO WARRANTIES OF MERCHANTABILITY, NON-INFRINGEMENT, OR FITNESS FOR ANY PARTICULAR PURPOSE; and (2) Xilinx shall not be liable (whether in contract or tort, including negligence, or under any other theory of liability) for any loss or damage of any kind or nature related to, arising under, or in connection with, the Materials (including your use of the Materials), including for any direct, indirect, special, incidental, or consequential loss or damage (including loss of data, profits, goodwill, or any type of loss or damage suffered as a result of any action brought by a third party) even if such damage or loss was reasonably foreseeable or Xilinx had been advised of the possibility of the same. Xilinx assumes no obligation to correct any errors contained in the Materials or to notify you of updates to the Materials or to product specifications. You may not reproduce, modify, distribute, or publicly display the Materials without prior written consent. Certain products are subject to the terms and conditions of the Limited Warranties which can be viewed at <http://www.xilinx.com/warranty.htm>; IP cores may be subject to warranty and support terms contained in a license issued to you by Xilinx. Xilinx products are not designed or intended to be fail-safe or for use in any application requiring fail-safe performance; you assume sole risk and liability for use of Xilinx products in Critical Applications: <http://www.xilinx.com/warranty.htm#critapps>.

© Copyright 2012-2013 Xilinx, Inc. Xilinx, the Xilinx logo, Artix, ISE, Kintex, Spartan, Virtex, Vivado, Zynq, and other designated brands included herein are trademarks of Xilinx in the United States and other countries. All other trademarks are the property of their respective owners.