

System Cache v1.01.a

Product Guide

PG031 July 25, 2012

Table of Contents

SECTION I: SUMMARY

IP Facts

Chapter 1: Overview

Feature Summary.....	6
Applications.....	11
Unsupported Features.....	13
Licensing and Ordering Information.....	14

Chapter 2: Product Specification

Standards Compliance.....	15
Performance.....	15
Resource Utilization.....	17
Port Descriptions.....	19
Register Space.....	20

Chapter 3: Designing with the Core

General Design Guidelines.....	28
Clocking.....	29
Resets.....	30
Protocol Description.....	30

SECTION II: VIVADO DESIGN SUITE

Chapter 4: Customizing and Generating the Core

GUI.....	32
Parameter Values.....	34

Chapter 5: Constraining the Core

Required Constraints.....	36
---------------------------	----

Device, Package, and Speed Grade Selections	36
Clock Frequencies	36
Clock Management	36
Clock Placement	36
Banking	36
Transceiver Placement	37
I/O Standard and Placement	37

SECTION III: ISE DESIGN SUITE

Chapter 6: Customizing and Generating the Core

GUI	39
Parameter Values	41

Chapter 7: Constraining the Core

SECTION IV: APPENDICES

Appendix A: Migrating

Port Changes	44
Functionality Changes	44

Appendix B: Application Software Development

Device Drivers	45
--------------------------	----

Appendix C: Additional Resources

Xilinx Resources	46
Solution Centers	46
References	46
Technical Support	47
Revision History	47
Notice of Disclaimer	47
Automotive Applications Disclaimer	48

SECTION I: SUMMARY

IP Facts

Overview

Product Specification

Designing with the Core

Introduction

The LogiCORE™ System Cache provides system level caching capability to an AMBA® AXI4 system. The System Cache resides in front of the external memory controller and is seen as a Level 2 Cache from the MicroBlaze™ processor point of view.

Features

- Dedicated AXI4 slave ports for MicroBlaze
- Connects up to 4 MicroBlaze processors
- Generic AXI4 slave port for other AXI4 masters
- AXI4 master port connecting the external memory controller
- Highly configurable cache
- Optional AXI4-Lite Statistics and Control port

LogiCORE IP Facts Table	
Core Specifics	
Supported Device Family ⁽¹⁾	Zynq™-7000 ⁽²⁾ , Virtex-7, Kintex™-7, Artix™-7, Virtex®-6, Spartan®-6,
Supported User Interfaces	
Resources	See Table 2-7 .
Provided with Core	
Design Files	ISE: VHDL Vivado: RTL
Example Design	Not Provided
Test Bench	Not Provided
Constraints File	Not Provided
Simulation Model	Not Provided
Supported S/W Driver	N/A
Tested Design Tools⁽³⁾	
Design Entry Tools	Vivado™ Design Suite ⁽⁴⁾ Xilinx Platform Studio (XPS)
Simulation	Mentor Graphics ModelSim
Synthesis Tools	Xilinx Synthesis Technology (XST) Vivado Synthesis
Support	
Provided by Xilinx @ www.xilinx.com/support	

Notes:

1. For a complete list of supported derivative devices, see the [Embedded Edition Derivative Device Support](#).
2. Supported in ISE Design Suite implementations only.
3. For the supported versions of the tools, see the [Xilinx Design Tools: Release Notes Guide](#).
4. Supports 7 series devices only.

Overview

Feature Summary

The System Cache can be added to an AXI system to improve overall system computing performance, regarding accesses to external memory. The System Cache is typically used in a MicroBlaze™ system implementing a Level 2 Cache with up to four MicroBlaze processors. The generic AXI4 interface provides access to the caching capability for all other AXI4 masters in the system.

Performance

The effect the System Cache has on performance is very system and application dependent. Application and system characteristics where performance improvements can be expected are:

- Applications with repeated access of data occupying a certain address range, for example, when external memory is used to buffer data during computations. In particular, performance improvements are achieved when the data set exceeds the capacity of the MicroBlaze internal data cache.
- Systems with small MicroBlaze caches, for example, when the MicroBlaze implementation is tuned to achieve as high frequency as possible. In this case, the increased system frequency contributes to the performance improvements, and the System Cache alleviates the performance loss incurred by the reduced size of the MicroBlaze internal caches.

Typical Systems

In a typical system with one MicroBlaze processor ([Figure 1-1](#)) the instruction and data cache interfaces (M_AXI_IC and M_AXI_DC) are connected to dedicated AXI4 interfaces optimized for MicroBlaze on the System Cache. The System Cache often makes it possible to reduce the MicroBlaze internal cache sizes, without reducing system performance. Non-MicroBlaze AXI4 interface masters are connected to the generic AXI4 slave interface of the System Cache through an AXI interconnect.

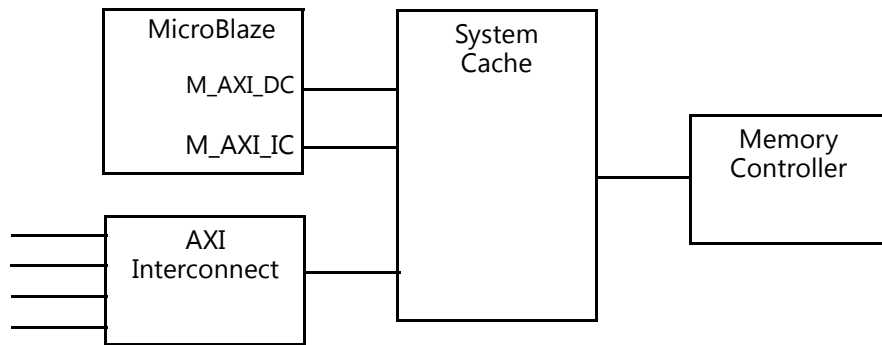

Figure 1-1: **Typical System With a Single Processor**

The System Cache can also be used in a system without any MicroBlaze processor, as shown in [Figure 1-2](#).

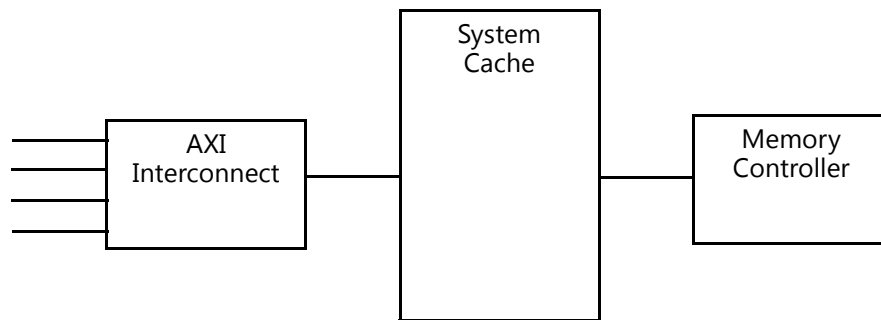

Figure 1-2: **System Without Processor**

The System Cache has eight cache interfaces optimized for MicroBlaze, enabling direct connection of up to four MicroBlaze processors, depicted in [Figure 1-3](#).

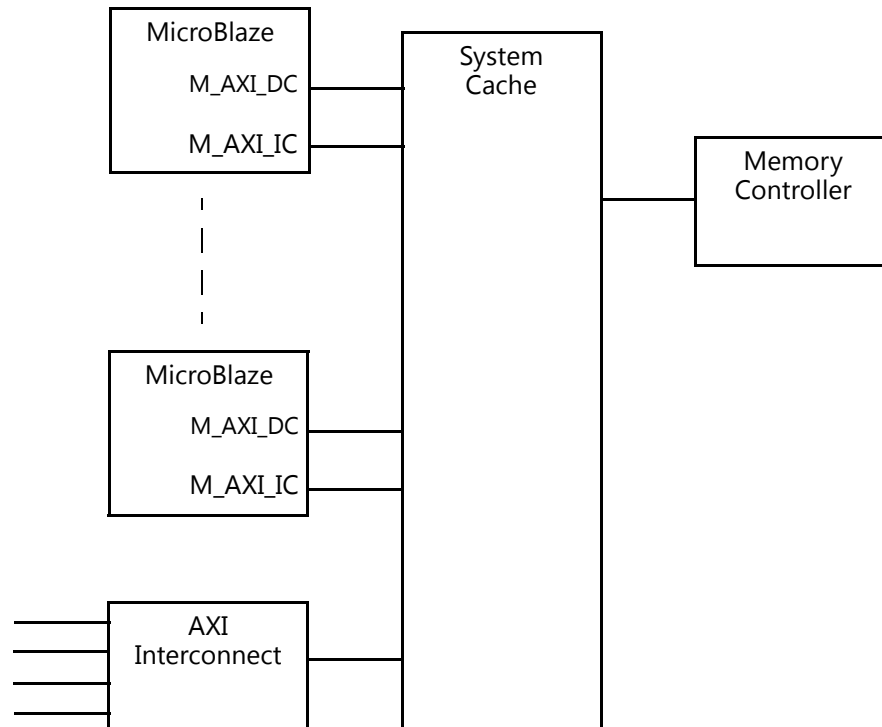

Figure 1-3: Typical System With Multiple MicroBlaze Processors

MicroBlaze Optimized AXI4 Slave Interface

The System Cache has eight AXI4 interfaces optimized for accesses performed by the cache interfaces on MicroBlaze. Because MicroBlaze has one AXI4 interface for the instruction cache and one for the data cache, systems with up to four MicroBlaze processors are supported.

By using a 1:1 AXI interconnect to directly connect MicroBlaze and the System Cache, access latency for MicroBlaze cache misses is reduced, which improves performance. The optimization to only handle the types of AXI4 accesses issued by MicroBlaze simplifies the implementation, saving area resources as well as improving performance. The data widths of the MicroBlaze optimized interfaces are parameterized to match the data widths of the connected MicroBlaze processors. With wide interfaces the MicroBlaze cache line length normally determines the data width.

The Optimized AXI4 slave interfaces are compliant to a subset of the AXI4 interface specification. The interface includes the subsequent features and exceptions:

- Support for 32-, 128-, 256-, and 512-bit data widths
- Support for some AXI4 burst types and sizes
 - No support for FIXED bursts

- WRAP bursts corresponding to the MicroBlaze cache line length, that is, either 4 beats or 8 beats
- Single beat INCR burst, or either 4 beats or 8 beats corresponding to the MicroBlaze cache line length
- Exclusive accesses are treated as a normal accesses, never returning EXOKAY
- Only support for native transaction size, that is, same as data width for the port
- Support for burst sizes that are less than the data width, with either 32-, 128-, 256-, or 512-bits
- AXI user signals are not necessary or supported
- All transactions executed in order regardless of thread ID value. No read reordering or write reordering is implemented.

Generic AXI4 Slave Interface

To handle several AXI4 masters in a system an AXI interconnect is used to share the single generic AXI4 slave interface on the System Cache. The generic AXI4 interface has a configurable data width to efficiently match the connected AXI4 masters. This ensures that both the system area and the AXI4 access latency are reduced.

The Generic AXI4 slave interface is compliant to the full AXI4 interface specification. The interface includes the subsequent features and exceptions:

- Support for 32-, 64-, 128-, 256-, and 512-bit data widths
- Support for all AXI4 burst types and sizes
 - FIXED bursts are handled as INCR type burst operations (no QUEUE burst capability)
 - 16 beats for WRAP bursts
 - 16 beats for FIXED bursts (treated as INCR burst type)
 - 256 beats for INCR burst
 - Exclusive accesses are treated as a normal accesses, never returning EXOKAY
- Support for burst sizes that are less than the data width, narrow bursts
- AXI user signals are not necessary or supported
- All transactions executed in order regardless of thread ID value. No read reordering or write reordering is implemented.

Memory Controller AXI4 Master Interface

The AXI4 master interface is used to connect the external memory controller. The data width of the interface can be parameterized to match the data width of the AXI4 slave interface on

the memory controller. For best performance and resource usage, the parameters on the interface and the Memory Controller should match.

The Memory Controller AXI4 master interface is compliant to the AXI4 interface specification. The interface includes the subsequent features:

- Support for 32-, 64-, 128-, 256-, and 512-bit data widths
- Generates the following AXI4 burst types and sizes
 - 2 - 16 beats for WRAP bursts
 - 1 - 16 beats for INCR burst
- AXI user signals are not provided
- A single thread ID value is generated

Cache Memory

The Cache memory provides the actual cache functionality in the System Cache. The cache is configurable in terms of size and associativity.

The cache size can be configured with the parameter `C_CACHE_SIZE` according to [Table 4-1](#). The selected size is a trade-off between performance and resource usage, in particular the number of Block RAMs.

The associativity can be configured with the parameter `C_NUM_SETS` according to [Table 4-1](#). Increased associativity generally provides better hit rate, which gives better performance but requires more area resources.

The correspondence between selected parameters and used block RAMs is listed in [Table 2-7](#).

Statistics and Control

The optional Statistics and Control block can be used to collect cache statistics such as cache hit rate and access latency. The statistics is primarily intended for internal Xilinx use, but can also be utilized to tailor the configuration of the System Cache to meet the needs of a specific application.

The following types of statistics are collected:

- Port statistics for each slave interface
 - Total Read and Write transaction counts
 - Port queue usage for the six transaction queues associated with each port
 - Cache hit rates for read and write
 - Read and Write transaction latency

- Arbitration statistics
- Functional unit statistics
 - Stall cycles
 - Internal queue usage
- Port statistics for the master interface
 - Read and write latency

For details on the registers used to read statistics and control how statistics is gathered, see [Chapter 2, Register Space](#).

Applications

An example of an Ethernet communication system is given in [Figure 1-4](#). The system consists of a MicroBlaze processor connected point-to-point to two optimized ports of the System Cache. A DMA controller is connected to the generic port of the System Cache through a 3:1 AXI interconnect, because the DMA controller has three AXI master ports. The DMA in turn is connected to the Ethernet IP by AXI4-Stream links. Standard peripheral functions like UART, timer, interrupt controller as well as the DMA controller control port are connected to the MicroBlaze peripheral data port (M_AXI_DP) for register configuration and control.

With this partitioning the bandwidth critical interfaces are connected directly to the System Cache and kept completely separated from the AXI4-Lite based configuration and control connections.

This system is used as an example throughout the documentation.

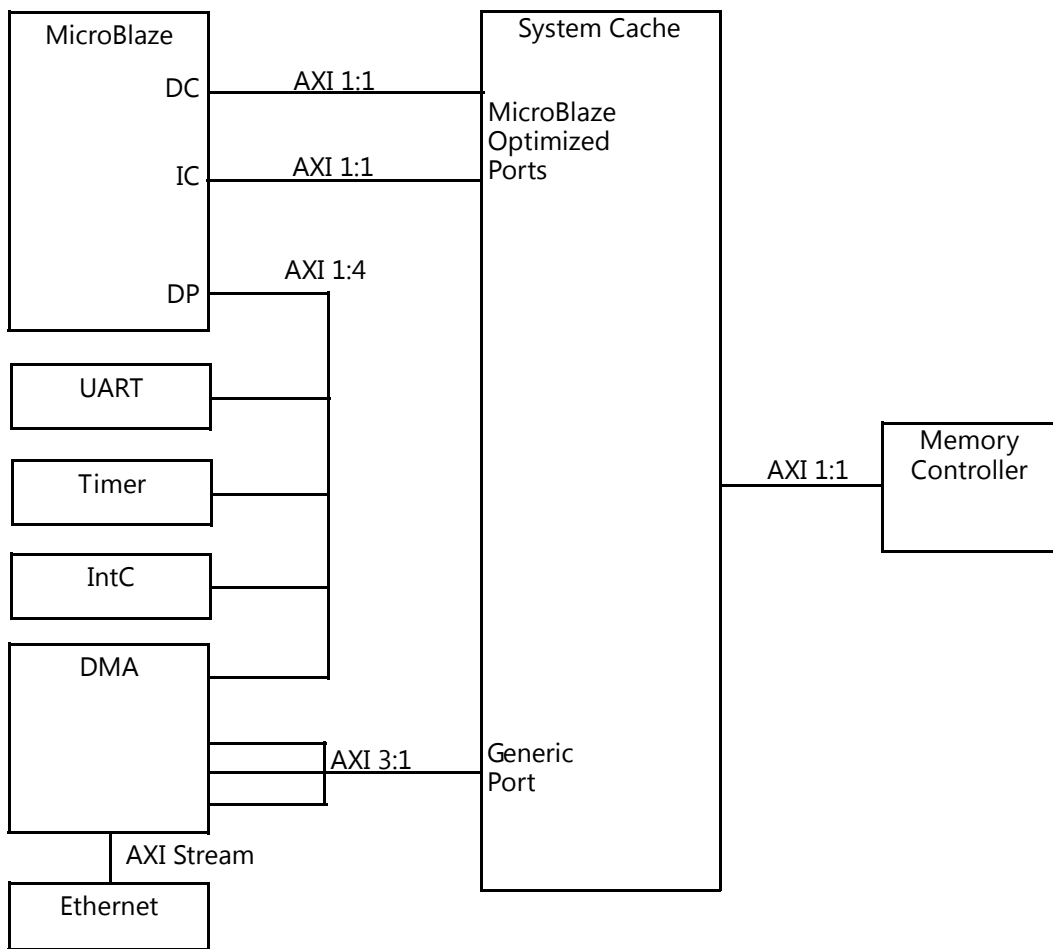

Figure 1-4: Ethernet System

In this example, MicroBlaze is configured for high performance while still being able to reach a high maximum frequency. The MicroBlaze frequency is mainly improved due to small cache sizes, implemented using distributed RAM.

The lower hit rate from small caches is mitigated by the higher system frequency and the use of the System Cache. The decreased hit rate in the MicroBlaze caches is compensated by cache hits in the System Cache, which incur less penalty than accesses to external memory.

Write-through data cache is enabled in MicroBlaze, which in the majority of cases gives higher performance than using write-back cache. The reverse is usually true when there is no System Cache.

Finally, victim cache is enabled for the MicroBlaze instruction cache, which improves the hit rate by storing the most recently discarded cache lines.

All AXI data widths on the System Cache ports are matched to the AXI data widths of the connecting modules to avoid data width conversions, which minimizes the AXI Interconnect

area overhead. The AXI 1:1 connections are only implemented as routing without any logic in this case.

All AXI ports are clocked using the same clock, which means that there is no need for clock conversion within the AXI interconnects. Avoiding clock conversion gives minimal area and latency for the AXI interconnects. The parameter settings for MicroBlaze and the System Cache can be found in [Table 1-1](#) and [Table 1-2](#), respectively

Table 1-1: MicroBlaze Parameter Settings for the Ethernet System

Parameter	Value
C_CACHE_BYTE_SIZE	512
C_ICACHE_ALWAYS_USED	1
C_ICACHE_LINE_LEN	8
C_ICACHE_STREAMS	0
C_ICACHE_VICTIMS	8
C_DCACHE_BYTE_SIZE	512
C_DCACHE_ALWAYS_USED	1
C_DCACHE_LINE_LEN	8
C_DCACHE_USE_WRITEBACK	0
C_DCACHE_VICTIMS	0

Table 1-2: System Cache Parameter Settings for the Ethernet System

Parameter	Value
C_NUM_OPTIMIZED_PORTS	2
C_NUM_GENERIC_PORTS	1
C_NUM_SETS	4
C_CACHE_SIZE	65536
C_M_AXI_DATA_WIDTH	32

Unsupported Features

The System Cache provides no support for coherency between the MicroBlaze internal caches. This means that software must ensure coherency for data exchanged between the processors. When the MicroBlaze processors use write-back data caches, all processors need to flush their caches to ensure correct data being exchanged. For write-through caches, it is only the processors reading data that need to flush their caches to ensure correct data being exchanged.

Licensing and Ordering Information

This Xilinx LogiCORE™ IP module is provided at no additional cost with the Xilinx Vivado™ Design Suite and ISE® Design Suite Embedded Edition tools under the terms of the [Xilinx End User License](#).

For information on pricing and availability of other Xilinx LogiCORE IP modules and tools, contact your [local Xilinx sales representative](#).

Product Specification

Standards Compliance

The System Core adheres to the AMBA® AXI4 Interface standard (see ARM® *AMBA AXI Protocol Specification, Version 2.0 ARM IHI 002C*).

Performance

The perceived performance is dependent on many factors such as frequency, latency and throughput. Which factor has the dominating effect is application-specific. There is also a correlation between the performance factors, for example, achieving high frequency can add latency and wide datapaths for throughput can affect frequency.

Maximum Frequencies

Table 2-1 shows the clock frequencies for the target families. The maximum achievable clock frequency can vary. The maximum achievable clock frequency and all resource counts can be affected by other tool options, additional logic in the FPGA, using a different version of Xilinx tools, and other factors.

Table 2-1: Maximum Frequencies

Architecture	Speed grade					
	(-1I)	(-1)	(-2I)	(-2)	(-3)	(-4)
Spartan®-6	90	N/A	N/A	130	140	150
Virtex®-6	180	205	N/A	235	255	N/A
Artix™-7	N/A	145	135	175	200	N/A
Kintex™-7	N/A	195	175	245	270	N/A
Virtex-7	N/A	205	175	240	270	N/A

Cache Latency

Read latency is defined as the clock cycle from the read address is accepted by the System Cache to the cycle when read data is available.

Write latency is defined as the clock cycle from the write address is accepted by the System Cache to the cycle when the response is valid.

The latency depends on many factors such as traffic from other ports and conflict with earlier transactions. The numbers in [Table 2-2](#) assume a completely idle System Cache and no write data delay for transactions on one of the optimized ports. For transactions using the Generic AXI port an additional two clock cycle latency is added.

Table 2-2: System Cache Latencies for Optimized Port

Type	Optimized Port Latency
Read Hit	5
Read Miss	6 + latency added by memory subsystem
Read Miss Dirty	Maximum of: <ul style="list-style-type: none"> 6 + latency added by memory subsystem 6 + latency added for evicting dirty data (cache line length * 32 / M_AXI Data Width)
Write Hit	2 + burst length
Write Miss	6 + latency added by memory subsystem for writing data

The numbers for an actual application varies depending on access patterns, hit/miss ratio and other factors. Example values from a system running the iperf network testing tool with the LWIP TCP/IP stack in raw mode are shown in [Table 2-3](#) to [Table 2-6](#). [Table 2-3](#) contains the hit rate for transactions from all ports. [Table 2-4](#), [Table 2-5](#) and [Table 2-6](#) show per port hit rate and latencies for the three active ports.

Table 2-3: Application Total Hit Rates

Type	Hit Rate
Read	99.73%
Write	90.71%

Table 2-4: System Cache Hit Rate and Latencies for MicroBlaze D-Side Port

Type	Hit Rate	Min	Max	Average	Standard Deviation
Read	99.66%	5	316	7	3
Write	94.35%	3	36	3	1

Table 2-5: System Cache Hit Rate and Latencies for MicroBlaze I-Side Port

Type	Hit Rate	Min	Max	Average	Standard Deviation
Read	99.92%	5	527	6	2
Write	N/A	N/A	N/A	N/A	N/A

Table 2-6: System Cache Hit Rate and Latencies for Generic Port

Type	Hit Rate	Min	Max	Average	Standard Deviation
Read	56.84%	7	404	24	15
Write	9.77%	6	104	24	5

Throughput

The System Cache is fully pipelined and can have a theoretical maximum transaction rate of one read or write hit data concurrent with one read and one write miss data per clock cycle when there are no conflicts with earlier transactions.

This theoretical limit is subject to memory subsystem bandwidth, intra-transaction conflicts and cache hit detection overhead, which reduce the achieved throughput to less than three data beats per clock cycle.

Resource Utilization

Resources required for the System Cache core have been estimated for the Kintex™-7 FPGA (Table 2-7). These values were generated using the Xilinx® ISE® tools, version 14.2. They are derived from post-synthesis reports, and might be changed by MAP and PAR.

Table 2-7: Kintex-7 System Cache FPGA Resource Estimates

Feature						Device Resources		
C_NUM_OPTIMIZED_PORTS	C_NUM_GENERIC_PORTS	C_NUM_SETS	C_S0_AXI_DATA_WIDTH	C_M_AXI_DATA_WIDTH	C_CACHE_SIZE	LUTs	FFs	Block RAMs
1	0	2	32	32	32KB	1481	866	10
2	0	2	32	32	32KB	1910	1010	10
4	0	2	32	32	32KB	2546	1298	10
8	0	2	32	32	32KB	3944	1861	10
0	1	2	32	32	32KB	2014	1192	10
2	1	2	32	32	32KB	2745	1494	10
2	0	4	32	32	32KB	2283	1184	9
2	0	2	32	32	64KB	1908	1007	18
2	0	2	32	32	128KB	1911	1004	34
2	0	2	32	512	128KB	7851	2333	34
2	0	2	512	512	128KB	8303	3177	34

Port Descriptions

The block diagram for System Cache is shown in [Figure 2-1](#). All System Cache interfaces are compliant with AXI4. The input signals `ACLK` and `ARESETN` implement clock and reset for the entire System Cache.

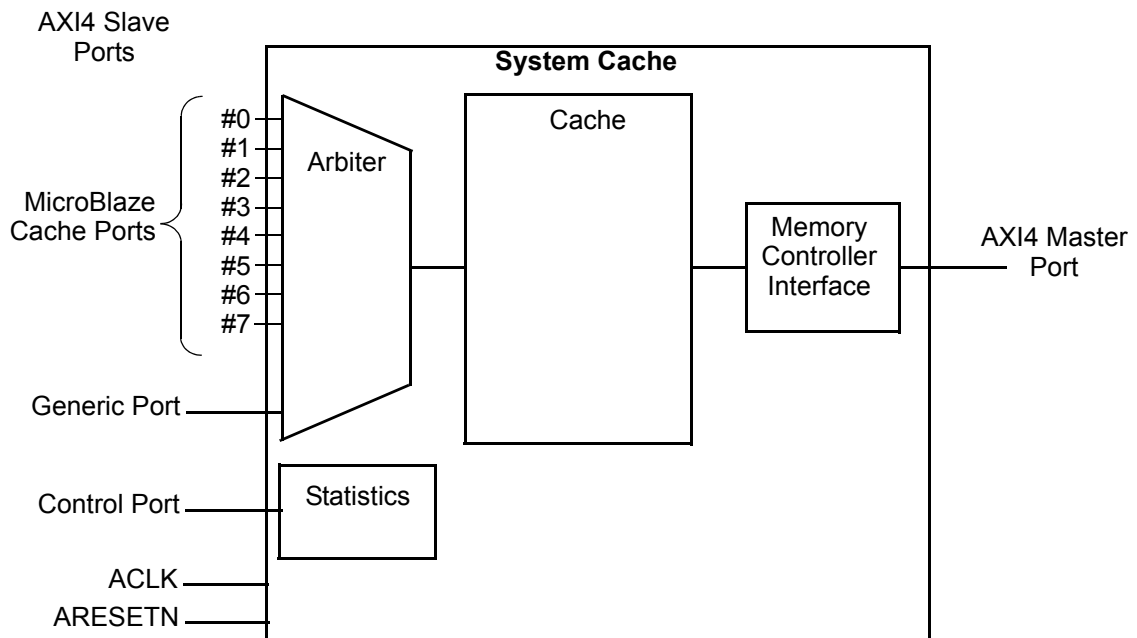

Figure 2-1: System Cache Block Diagram

Table 2-8: System Cache I/O Interfaces

Interface Name	Type	Description
<code>ACLK</code>	Input	Clock for System Cache
<code>ARESETN</code>	Input	Synchronous reset of System Cache
<code>Sx_AXI</code>	AXI4 Slave	MicroBlaze Optimized Cache Port
<code>S0_AXI_GEN</code>	AXI4 Slave	Generic Cache Port
<code>M_AXI</code>	AXI4 Master	Memory Controller Master Port
<code>S_AXI_CTRL</code>	AX4-lite Slave	Control port

1. x = 0 - 7

Register Space

All registers in the optional Statistics module are 64-bits wide. The address map is structure according to [Table 2-9](#).

Table 2-9: Address Structure

Category	Port Number	Functionality	Register	High/Low	Always 00
16	14 12	10 9	5 4	3 2	1 0

The address coding of all functional units in the System Cache with statistic gathering capability is defined by [Table 2-10](#).

Table 2-10: System Cache Address Map, Category and Port Number Field

Address (binary)	Category and Port number	Description
0_0000_00xx_xxxx_xx00	Optimized port 0	All statistics for Optimized port #0 defined in Table 2-11 when used, 0 otherwise.
0_0000_01xx_xxxx_xx00	Optimized port 1	All statistics for Optimized port #1 defined in Table 2-11 when used, 0 otherwise.
0_0000_10xx_xxxx_xx00	Optimized port 2	All statistics for Optimized port #2 defined in Table 2-11 when used, 0 otherwise.
0_0000_11xx_xxxx_xx00	Optimized port 3	All statistics for Optimized port #3 defined in Table 2-11 when used, 0 otherwise.
0_0001_00xx_xxxx_xx00	Optimized port 4	All statistics for Optimized port #4 defined in Table 2-11 when used, 0 otherwise.
0_0001_01xx_xxxx_xx00	Optimized port 5	All statistics for Optimized port #5 defined in Table 2-11 when used, 0 otherwise.
0_0001_10xx_xxxx_xx00	Optimized port 6	All statistics for Optimized port #6 defined in Table 2-11 when used, 0 otherwise.
0_0001_11xx_xxxx_xx00	Optimized port 7	All statistics for Optimized port #7 defined in Table 2-11 when used, 0 otherwise.
0_0100_00xx_xxxx_xx00	Generic port	All statistics for the Generic port defined in Table 2-12 when used, 0 otherwise.
0_1000_00xx_xxxx_xx00	Arbiter	Statistics available in arbiter stage defined in Table 2-13
0_1100_00xx_xxxx_xx00	Access	Statistics available in access stage defined in Table 2-14
1_0000_00xx_xxxx_xx00	Lookup	Statistics available in lookup stage defined in Table 2-15
1_0100_00xx_xxxx_xx00	Update	Statistics available in update stage defined in Table 2-16
1_1000_00xx_xxxx_xx00	Backend	Statistics available in backend stage defined in Table 2-17
1_1100_00xx_xxxx_xx00	Control	Control registers defined in Table 2-18

The address decoding of the MicroBlaze™ optimized ports statistics functionality is shown in [Table 2-11](#).

Table 2-11: System Cache Address Map, Statistics Field for Optimized Port

Address (binary)	Functionality	R/W	Statistics Format	Description
x_xxxx_xx00_000x_xx00	Read Segments	R	COUNT ⁽¹⁾	Number of segments per read transaction
x_xxxx_xx00_001x_xx00	Write Segments	R	COUNT ⁽¹⁾	Number of segments per write transaction
x_xxxx_xx00_010x_xx00	RIP	R	QUEUE ⁽²⁾	Read Information Port queue statistics
x_xxxx_xx00_011x_xx00	R	R	QUEUE ⁽²⁾	Read data queue statistics
x_xxxx_xx00_100x_xx00	BIP	R	QUEUE ⁽²⁾	BRESP Information Port queue statistics
x_xxxx_xx00_101x_xx00	BP	R	QUEUE ⁽²⁾	BRESP Port queue statistics
x_xxxx_xx00_110x_xx00	WIP	R	QUEUE ⁽²⁾	Write Information Port queue statistics
x_xxxx_xx00_111x_xx00	W	R	QUEUE ⁽²⁾	Write data queue statistics
x_xxxx_xx01_000x_xx00	Read Blocked	R	COUNT ⁽¹⁾	Number of cycles a read was prohibited from taking part in arbitration
x_xxxx_xx01_001x_xx00	Write Hit	R	COUNT ⁽¹⁾	Number of write hits
x_xxxx_xx01_010x_xx00	Write Miss	R	COUNT ⁽¹⁾	Number of write misses
x_xxxx_xx01_011x_xx00	Write Miss Dirty	R	COUNT ⁽¹⁾	Number of dirty write misses
x_xxxx_xx01_100x_xx00	Read Hit	R	COUNT ⁽¹⁾	Number of read hits
x_xxxx_xx01_101x_xx00	Read Miss	R	COUNT ⁽¹⁾	Number of read misses
x_xxxx_xx01_110x_xx00	Read Miss Dirty	R	COUNT ⁽¹⁾	Number of dirty read misses
x_xxxx_xx01_111x_xx00	Locked Write Hit	R	COUNT ⁽¹⁾	Number of locked write hits
x_xxxx_xx10_000x_xx00	Locked Read Hit	R	COUNT ⁽¹⁾	Number of locked read hits
x_xxxx_xx10_001x_xx00	First Write Hit	R	COUNT ⁽¹⁾	Number of first write hits
x_xxxx_xx10_010x_xx00	Read Latency	R	COUNT ⁽¹⁾	Read latency statistics
x_xxxx_xx10_011x_xx00	Write Latency	R	COUNT ⁽¹⁾	Write latency statistics
x_xxxx_xx10_100x_xx00	Read Latency Configuration	R/W	LONGINT ⁽³⁾	Configuration for read latency statistics collection. Default value 0. Available modes are defined in Table 2-26 .
x_xxxx_xx10_101x_xx00	Write Latency Configuration	R/W	LONGINT ⁽³⁾	Configuration for read latency statistics collection. Default value 4. Available modes are defined in Table 2-27 .

Notes:

1. See [Table 2-19](#) for the COUNT register fields
2. See [Table 2-20](#) for the QUEUE register fields.
3. See [Table 2-21](#) for the LONGINT register fields.

The address decoding to the statistics functionality in the Generic ports is shown in [Table 2-12](#).

Table 2-12: System Cache Address Map, Statistics Field for Generic Port

Address (binary)	Functionality	R/W	Statistics Format	Description
x_xxxx_xx00_000x_xx00	Read Segments	R	COUNT ⁽¹⁾	Number of segments per read transaction
x_xxxx_xx00_001x_xx00	Write Segments	R	COUNT ⁽¹⁾	Number of segments per write transaction
x_xxxx_xx00_010x_xx00	RIP	R	QUEUE ⁽²⁾	Read Information Port queue statistics
x_xxxx_xx00_011x_xx00	R	R	QUEUE ⁽²⁾	Read data queue statistics
x_xxxx_xx00_100x_xx00	BIP	R	QUEUE ⁽²⁾	BRESP Information Port queue statistics
x_xxxx_xx00_101x_xx00	BP	R	QUEUE ⁽²⁾	BRESP Port queue statistics
x_xxxx_xx00_110x_xx00	WIP	R	QUEUE ⁽²⁾	Write Information Port queue statistics
x_xxxx_xx00_111x_xx00	W	R	QUEUE ⁽²⁾	Write data queue statistics
x_xxxx_xx01_000x_xx00	Read Blocked	R	COUNT ⁽¹⁾	Number of cycles a read was prohibited from taking part in arbitration
x_xxxx_xx01_001x_xx00	Write Hit	R	COUNT ⁽¹⁾	Number of write hits
x_xxxx_xx01_010x_xx00	Write Miss	R	COUNT ⁽¹⁾	Number of write misses
x_xxxx_xx01_011x_xx00	Write Miss Dirty	R	COUNT ⁽¹⁾	Number of dirty write misses
x_xxxx_xx01_100x_xx00	Read Hit	R	COUNT ⁽¹⁾	Number of read hits
x_xxxx_xx01_101x_xx00	Read Miss	R	COUNT ⁽¹⁾	Number of read misses
x_xxxx_xx01_110x_xx00	Read Miss Dirty	R	COUNT ⁽¹⁾	Number of dirty read misses
x_xxxx_xx01_111x_xx00	Locked Write Hit	R	COUNT ⁽¹⁾	Number of locked write hits
x_xxxx_xx10_000x_xx00	Locked Read Hit	R	COUNT ⁽¹⁾	Number of locked read hits
x_xxxx_xx10_001x_xx00	First Write Hit	R	COUNT ⁽¹⁾	Number of first write hits
x_xxxx_xx10_010x_xx00	Read Latency	R	COUNT ⁽¹⁾	Read latency statistics
x_xxxx_xx10_011x_xx00	Write Latency	R	COUNT ⁽¹⁾	Write latency statistics
x_xxxx_xx10_100x_xx00	Read Latency Configuration	R/W	LONGINT ⁽³⁾	Configuration for read latency statistics collection. Default value 0. Modes available defined in Table 2-26
x_xxxx_xx10_101x_xx00	Write Latency Configuration	R/W	LONGINT ⁽³⁾	Configuration for read latency statistics collection. Default value 4. Modes available defined in Table 2-27

Notes:

1. See [Table 2-19](#) for the COUNT register fields.
2. See [Table 2-20](#) for the QUEUE register fields.
3. See [Table 2-21](#) for the LONGINT register fields.

The address decoding to the statistics functionality in the Arbiter functional unit is shown in [Table 2-13](#).

Table 2-13: System Cache Address Map, Statistics Field for Arbiter

Address (binary)	Functionality	R/W	Statistics Format	Description
x_xxxx_xx00_000x_xx00	Valid	R	COUNT ⁽¹⁾	The number of clock cycles a transaction takes after being arbitrated
x_xxxx_xx00_001x_xx00	Concurrent	R	COUNT ⁽¹⁾	Number of transactions available to select from when arbitrating

1. See [Table 2-19](#) for the COUNT register fields.

The address decoding to the statistic functionality in the Access functional unit is shown in [Table 2-14](#).

Table 2-14: System Cache Address Map, Statistics Field for Access

Address (binary)	Functionality	R/W	Statistics Format	Description
x_xxxx_xx00_000x_xx00	Valid	R	COUNT ⁽¹⁾	The number of clock cycles a transaction takes after passing the access stage

1. See [Table 2-19](#) for the COUNT register fields.

The address decoding to the statistic functionality in the Access functional unit is shown in [Table 2-15](#).

Table 2-15: System Cache Address Map, Statistics Field for Lookup

Address (binary)	Functionality	R/W	Statistics Format	Description
x_xxxx_xx00_000x_xx00	Fetch Stall	R	COUNT ⁽¹⁾	Time fetch stalls because of conflict
x_xxxx_xx00_001x_xx00	Mem Stall	R	COUNT ⁽¹⁾	Time mem stalls because of conflict
x_xxxx_xx00_010x_xx00	Data Stall	R	COUNT ⁽¹⁾	Time stalled due to memory access
x_xxxx_xx00_011x_xx00	Data Hit Stall	R	COUNT ⁽¹⁾	Time stalled due to conflict
x_xxxx_xx00_100x_xx00	Data Miss Stall	R	COUNT ⁽¹⁾	Time stalled due to full buffers

1. See [Table 2-19](#) for the COUNT register fields.

The address decoding to the statistic functionality in the Update functional unit is shown in [Table 2-16](#).

Table 2-16: System Cache Address Map, Statistics Field for Update

Address (binary)	Functionality	R/W	Statistics Format	Description
x_xxxx_xx00_000x_xx00	Stall	R	COUNT ⁽¹⁾	Cycles transactions are stalled
x_xxxx_xx00_001x_xx00	Tag Free	R	COUNT ⁽¹⁾	Cycles tag is free
x_xxxx_xx00_010x_xx00	Data free	R	COUNT ⁽¹⁾	Cycles data is free
x_xxxx_xx00_011x_xx00	Read Information	R	QUEUE ⁽²⁾	Queue statistics for read transactions

Table 2-16: System Cache Address Map, Statistics Field for Update (Cont'd)

Address (binary)	Functionality	R/W	Statistics Format	Description
x_xxxx_xx00_100x_xx00	Read Data	R	QUEUE ⁽²⁾	Queue statistics for read data
x_xxxx_xx00_101x_xx00	Evict	R	QUEUE ⁽²⁾	Queue statistics for evict information
x_xxxx_xx00_110x_xx00	BRESP Source	R	QUEUE ⁽²⁾	Queue statistics for BRESP source information
x_xxxx_xx00_111x_xx00	Write Miss	R	QUEUE ⁽²⁾	Queue statistics for write miss information
x_xxxx_xx01_000x_xx00	Write Miss Allocate	R	QUEUE ⁽²⁾	Queue statistics for allocated write miss data

Notes:

1. See [Table 2-19](#) for the COUNT register fields.
2. See [Table 2-20](#) for the QUEUE register fields.

The address decoding to the statistic functionality in the Backend functional unit is shown in [Table 2-17](#).

Table 2-17: System Cache Address Map, Statistics Field for Backend

Address (binary)	Functionality	R/W	Statistics Format	Description
x_xxxx_xx00_000x_xx00	Write Address	R	QUEUE ⁽¹⁾	Queue statistics for write address channel information
x_xxxx_xx00_001x_xx00	Write Data	R	QUEUE ⁽¹⁾	Queue statistics for write channel data
x_xxxx_xx00_010x_xx00	Read Address	R	QUEUE ⁽¹⁾	Queue statistics for read address channel information
x_xxxx_xx00_011x_xx00	Search Depth	R	COUNT ⁽²⁾	Transaction search depth for read access before released
x_xxxx_xx00_100x_xx00	Read Stall	R	COUNT ⁽²⁾	Cycles stall due to search
x_xxxx_xx00_101x_xx00	Read Protected Stall	R	COUNT ⁽²⁾	Cycles stall due to conflict
x_xxxx_xx00_110x_xx00	Read Latency	R	COUNT ⁽²⁾	Read latency statistics for external transactions to memory
x_xxxx_xx00_111x_xx00	Write Latency	R	COUNT ⁽²⁾	Write latency statistics for external transactions to memory
x_xxxx_xx01_000x_xx00	Read Latency Configuration	R/W	LONGINT ⁽³⁾	Configuration for read latency statistics collection. Default value 0. Available modes are defined in Table 2-26
x_xxxx_xx01_001x_xx00	Write Latency Configuration	R/W	LONGINT ⁽³⁾	Configuration for read latency statistics collection. Default value 4. Available modes are defined in Table 2-27

Notes:

1. See [Table 2-20](#) for the QUEUE register fields.
2. See [Table 2-19](#) for the COUNT register fields.
3. See [Table 2-21](#) for the LONGINT register fields.

The address decoding to the statistic functionality in the Backend functional unit is shown in [Table 2-17](#).

Table 2-18: System Cache Address Map, Control

Address (binary)	Functionality	R/W	Statistics Format	Description
x_xxxx_xx00_000x_xx00	Reset	W	LONGINT ⁽¹⁾	Writing to this register resets all statistic data
x_xxxx_xx00_001x_xx00	Enable	R/W	LONGINT ⁽¹⁾	Configuration for enabling statistics collection. Default value 1. Available modes are defined in Table 2-28

1. See [Table 2-21](#) for the LONGINT register fields.

The address decoding to the different registers in a statistic record being of type COUNT is shown in [Table 2-19](#).

Table 2-19: System Cache Address Map, Register Field for COUNT

Address (binary)	Register	R/W	Format	Description
x_xxxx_xxxx_xxx0_0x00	Events	R	LONGINT ⁽¹⁾	Number of times the event has been triggered
x_xxxx_xxxx_xxx0_1x00	Min Max Status	R	MINMAX ⁽²⁾	Min, max and status information defined according to Table 2-24
x_xxxx_xxxx_xxx1_0x00	Sum	R	LONGINT ⁽¹⁾	Sum of measured data
x_xxxx_xxxx_xxx1_1x00	Sum ²	R	LONGINT ⁽¹⁾	Sum of measured data squared

Notes:

1. See [Table 2-21](#) for the LONGINT register fields.
2. See [Table 2-22](#) for the MINMAX register fields.

The address the different registers in a statistic record of type QUEUE is shown in [Table 2-20](#).

Table 2-20: System Cache Address Map, Register Field for QUEUE

Address (binary)	Register	R/W	Format	Description
x_xxxx_xxxx_xxx0_0x00	Empty Cycles	R	LONGINT ⁽¹⁾	Clock cycles the queue has been idle
x_xxxx_xxxx_xxx0_1x00	Index Updates	R	LONGINT ⁽¹⁾	Number of times updated with push or pop
x_xxxx_xxxx_xxx1_0x00	Index Max	R	MINMAX ⁽²⁾	Maximum depth for queue (only maximum field used)
x_xxxx_xxxx_xxx1_1x00	Index Sum	R	LONGINT ⁽¹⁾	Sum of queue depth when updated

Notes:

1. See [Table 2-21](#) for the LONGINT register fields.
2. See [Table 2-22](#) for the MINMAX register fields.

The address decoding of the 64-bit vector LONGINT is shown in [Table 2-21](#).

Table 2-21: System Cache Address Map, High-Low Field for LONG INT

Address (binary)	High Low	Description
x_XXXX_XXXX_XXXX_x000	LOW	LONGINT Bits 31-0, least significant half
x_XXXX_XXXX_XXXX_x100	HIGH	LONGINT Bits 63-32, most significant half

The address decoding of the 64-bit vector MIN MAX is shown in [Table 2-22](#).

Table 2-22: System Cache Address Map, High-Low Field for MIN MAX

Address (binary)	High Low	Description
x_XXXX_XXXX_XXXX_x000	LOW	MIN MAX Bits 31-0
x_XXXX_XXXX_XXXX_x100	HIGH	MIN MAX Bits 63-32

Bit field definition of the LONG INT register is shown in [Table 2-23](#).

Table 2-23: LONG INT Register Bit Allocation

Long Integer	
63	0

Bit field definition of the MIN MAX register is shown in [Table 2-24](#).

Table 2-24: MIN MAX Register Bit Allocation

Min	Max	reserved	Full	Over flow			
63	48	47	32	31	2	1	0

Field definitions for MIN MAX register type shown in [Table 2-25](#).

Table 2-25: MIN MAX Field Definition

Field	Description
Min	Minimum unsigned measurement encountered
Max	Maximum unsigned measurement encountered, saturates when 0xFFFF is reached
Full	Flag if number of concurrent events of the measured type has been reached, indicating that the resulting statistics are inaccurate.
Overflow	Flag if measurements have been saturated; this means the statistics results are less accurate. Both average and standard deviation measurements will be lower than the actual values.

Mode definitions for read latency measurements is shown in [Table 2-26](#).

Table 2-26: Read Latency Measurement

Value	Description
0	AR channel valid until first data is acknowledged
1	AR channel acknowledged until first data is acknowledged
2	AR channel valid until last data is acknowledged
3	AR channel acknowledged until last data is acknowledged

Mode definitions for write latency measurements are shown in [Table 2-27](#).

Table 2-27: Write Latency Measurement

Value	Description
0	AW channel valid until first data is written
1	AW channel acknowledged until first data is written
2	AW channel valid until last data is written
3	AW channel acknowledged until last data is written
4	AW channel valid until BRESP is acknowledged
5	AW channel acknowledged until BRESP is acknowledged

Mode definitions for statistics enable are shown in [Table 2-28](#).

Table 2-28: Statistics Enable Configuration

Value	Description
0	Statistics collection disabled
1	Statistics collection enabled

Designing with the Core

This chapter includes guidelines and additional information to make designing with the core easier.

General Design Guidelines

There are no golden settings to achieve maximum performance for all cases, as performance is application and system dependent. This chapter contains general guidelines that should be considered when configuring System Cache and other IP cores to improve performance.

AXI Data Widths

AXI Data widths should match wherever possible. Matching widths results in minimal area overhead and latency for the AXI interconnects.

AXI Clocking

The System Cache is fully synchronous. Using the same clock for all the AXI ports removes the need for clock conversion blocks and results in minimal area overhead and latency for the AXI interconnects.

Frequency and Hit Rate

Increased cache hit rate results in higher performance.

The System Cache size should be configured to be larger than the connected L1 caches to achieve any improvements. Increasing the System Cache size increases hit rate and has a positive effect on performance. The downside of increasing the System Cache size is an increased number of FPGA resources being used. Higher set associativity usually increases the hit rate and the application performance.

The maximum frequency of MicroBlaze™ is affected by its cache sizes. Smaller MicroBlaze cache sizes usually means that MicroBlaze can meet higher frequency targets. The sweet spot for the frequency versus cache size trade-off when using the System Cache occurs when configuring MicroBlaze caches to either 256 or 512 bytes, depending on other

MicroBlaze configuration settings. The key to improve frequency is to implement MicroBlaze cache tags with distributed RAM.

Enabling the MicroBlaze Branch Target Cache can improve performance but might reduce the maximum obtainable frequency. Depending on the rest of the MicroBlaze configuration smaller BTC sizes, such as 32 entries (`C_BRANCH_TARGET_CACHE_SIZE = 3`), should be considered.

Enabling MicroBlaze victim caches increases MicroBlaze cache hit rates, with improved performance as a result. Enabling victim caches can however reduce MicroBlaze maximum frequency in some cases. Instruction stream cache should be disabled, because it usually reduces performance when connected to System Cache. MicroBlaze performance is often improved by using 8-word cache lines on the Instruction Cache and Data Cache.

Bandwidth

Using wider AXI interfaces increases data bandwidth, but also increases FPGA resource usage. Using the widest possible common AXI data width between the System Cache AXI Master and the external memory gives the highest possible bandwidth. This also applies to the AXI connection between MicroBlaze caches and the System Cache. The widest possible common width gives the highest bandwidth.

Arbitration

The System Cache arbitration scheme is round-robin. When the selected port does not have a pending transaction, the first port with an available transaction is scheduled, considering the optimized ports in ascending numeric order and finally the generic port.

Only one read request per port is processed at a time. While one port has a read in progress no other reads from the same port are scheduled. A write from any port or read from any other port with no read in progress can be arbitrated during this time.

Clocking

The System Cache is fully synchronous with all interfaces and the internal function clocked by the `ACLK` input signal. It is advisable to avoid asynchronous clock transitions in the system as they add latency and consumes area resources.

Resets

The System Cache is reset by the ARESETN input signal. ARESETN is synchronous to ACLK and needs be asserted one ACLK cycle to take affect. The System Cache is ready for operation two ACLK cycles after ARESETN is deasserted.

Protocol Description

All interfaces to the System Cache adhere to the AXI4 protocol.

SECTION II: VIVADO DESIGN SUITE

Customizing and Generating the Core

Constraining the Core

Customizing and Generating the Core

This chapter includes information on using Xilinx® tools to customize and generate the core in the Vivado™ Design Suite.

GUI

The System Cache parameters are divided into two categories: core and system. See [Table 4-1](#) for allowed values.

The core parameter tab is shown in [Figure 4-1](#).

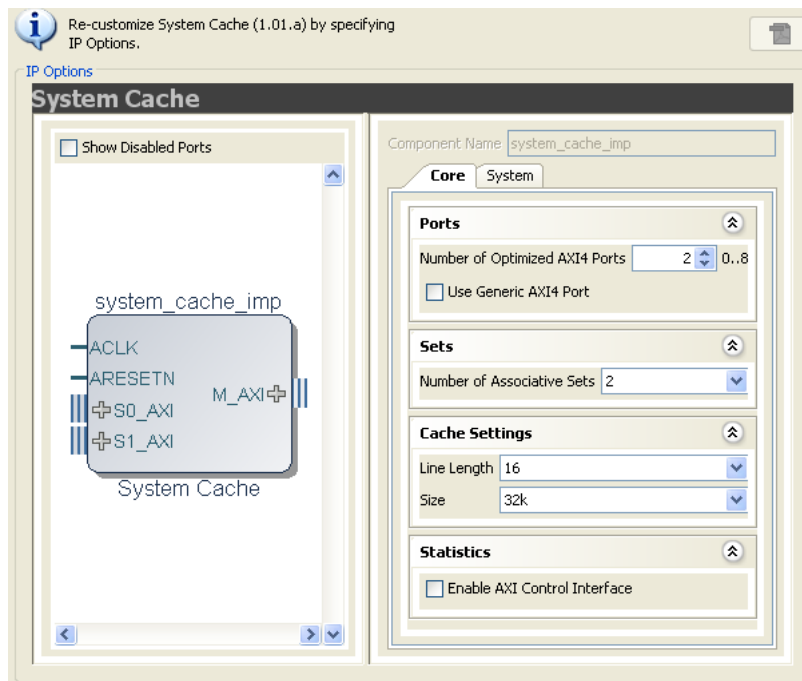

Figure 4-1: Core Parameter Tab

- **Number of Optimized AXI4 Ports** - Sets the number of optimized ports that are available to connect to a MicroBlaze™ or equivalent IP in terms of AXI4 transaction support.
- **Use Generic AXI4 Port** - Set if the Generic AXI4 port are available for IPs not adhering to the AXI4 subset required for the optimized port, such as DMA etc.

- **Number of Associative Sets** - Specify how many sets the associativity uses.
- **Line Length** - System Cache cache line length is fixed to 16.
- **Size** - Sets the size of the System Cache in bytes.
- **Enable AXI Control Interface** - Set if statistics interface is available.

The system parameter tab is shown in [Figure 4-2](#) with the data width parameters visible for the slave interfaces.

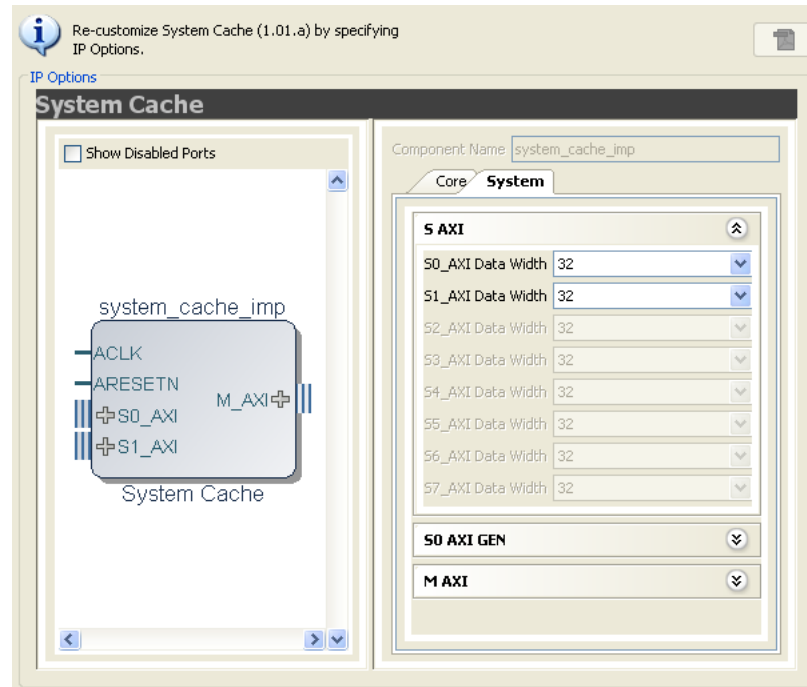

Figure 4-2: System Parameter Tab

- **Sx_AXI Data Width** - Sets the data width of the Optimized ports individually.
- **S0_AXI_GEN Data Width** - Sets the data width of the Generic port.
- **M_AXI Data Width** - Sets the data width of the master interface that is connected to the memory subsystem.

All frequency and interconnect related parameters are hidden in the Vivado interface and handled automatically in the background.

Parameter Values

Certain parameters are only available in some configurations, others impose restrictions that IP cores connected to the System Cache need to adhere to. All these restrictions are enforced by Design Rule Checks to guarantee a valid configuration. Table 4-1 describes the System Cache Parameters.

The parameter restrictions are:

- Internal cache data width must either be 32 or a multiple of the cache line length of masters connected to the optimized ports ($C_CACHE_DATA_WIDTH = 32$ or $C_CACHE_DATA_WIDTH = n * 32 * C_Lx_CACHE_LINE_LENGTH$).
- All Optimized slave port data widths must be less than or equal to the internal cache data width ($C_Sx_AXI_DATA_WIDTH \leq C_CACHE_DATA_WIDTH$).
- Generic slave port data width must be less than or equal to the internal cache data width ($C_S0_AXI_GEN_DATA_WIDTH \leq C_CACHE_DATA_WIDTH$).
- The master port data width must be greater then or equal to the internal cache data width ($C_CACHE_DATA_WIDTH \leq C_M_AXI_DATA_WIDTH$).
- The internal cache line length must be greater than or equal to the corresponding cache line length of the AXI masters connected to the optimized port ($C_CACHE_LINE_LENGTH \geq C_Lx_CACHE_LINE_LENGTH$).

Table 4-1: System Cache I/O Interfaces

Parameter Name	Feature/Description	Allowable Values	Default Value	VHDL Type
C_FAMILY	FPGA Architecture	Supported architectures	virtex6	string
C_INSTANCE	Instance Name	Any instance name	system_cache	string
C_FREQ	System Cache clock frequency	Any valid frequency for the device	0	natural
C_BASEADDR	Cacheable area base address		0xFFFFFFFF	std_logic_vector
C_HIGHADDR	Cacheable area high address. Minimum size is 32KB		0x00000000	std_logic_vector
C_ENABLE_CTRL	Enable implementation of Statistics and Control function	0, 1	0	natural
C_NUM_OPTIMIZED_PORTS	Number of ports optimized for MicroBlaze cache connection	0 - 8	1	natural
C_NUM_GENERIC_PORTS	Number of ports supporting full AXI4	0, 1	0	natural
C_NUM_SETS	Cache associativity	2, 4	2	natural

Table 4-1: System Cache I/O Interfaces (Cont'd)

Parameter Name	Feature/Description	Allowable Values	Default Value	VHDL Type
C_CACHE_DATA_WIDTH	Cache data width used internally. Automatically calculated to match AXI master interface	32, 64, 128, 256, 512	32	natural
C_CACHE_LINE_LENGTH	Cache line length. Constant value.	16	16	natural
C_CACHE_SIZE	Cache size in bytes	32768, 65536, 131072, 262144, 524288	32768	natural
C_Lx_CACHE_LINE_LENGTH	Cache line length on masters connected to optimized ports. Automatically assigned with manual override	4, 8	4	natural
MicroBlaze cache optimized AXI4 slave interface parameters				
C_Sx_AXI_ADDR_WIDTH ⁽¹⁾	Address width. Constant value.	32	32	natural
C_Sx_AXI_DATA_WIDTH ⁽¹⁾	Data width	32, 128, 256, 512	32	natural
C_Sx_AXI_ID_WIDTH ⁽¹⁾	ID width, automatically assigned	1 - 32	1	natural
Generic AXI4 slave interface parameters				
C_S0_AXI_GEN_ADDR_WIDTH	Address Width. Constant value.	32	32	natural
C_S0_AXI_GEN_DATA_WIDTH	Data Width	32, 64, 128, 256, 512	32	natural
C_S0_AXI_GEN_ID_WIDTH	ID width, automatically assigned	1 - 32	1	natural
Statistics and Control AXI4-Lite slave interface parameters				
C_S_AXI_CTRL_BASEADDR	Control area base address		0xFFFFFFFF	std_logic_vector
C_S_AXI_CTRL_HIGHADDR	Control area high address. Minimum size is 128KB		0x00000000	std_logic_vector
C_S_AXI_CTRL_ADDR_WIDTH	Address Width. Constant value.	32	32	natural
C_S_AXI_CTRL_DATA_WIDTH	Data Width. Constant value.	32	32	natural
Memory Controller AXI4 master interface parameters				
C_M_AXI_ADDR_WIDTH	Address Width. Constant value.	32	32	natural
C_M_AXI_DATA_WIDTH	Data Width	32, 128, 256, 512	32	natural
C_M_AXI_THREAD_ID_WIDTH	ID width. Automatically assigned with manual override	1 - 32	1	natural

1. x = 0 - 7

Constraining the Core

Required Constraints

There are no required constraints for this core.

Device, Package, and Speed Grade Selections

There are no Device, Package or Speed Grade requirements for this core.

Clock Frequencies

There are no specific clock frequency requirements for this core.

Clock Management

There are no specific clock management requirements for this core.

Clock Placement

There are no specific Clock placement requirements for this core.

Banking

There are no specific Banking rules for this core.

Transceiver Placement

There are no Transceiver Placement requirements for this core.

I/O Standard and Placement

There are no specific I/O standards and placement requirements for this core.

SECTION III: ISE DESIGN SUITE

Customizing and Generating the Core

Constraining the Core

Customizing and Generating the Core

This chapter includes information on using Xilinx® tools to customize and generate the core in the ISE® Design Suite.

GUI

The System Cache parameters are divided into three categories: core, system and interconnect related. See [Table 4-1](#) for allowed values.

The core parameter tab is shown in [Figure 6-1](#).

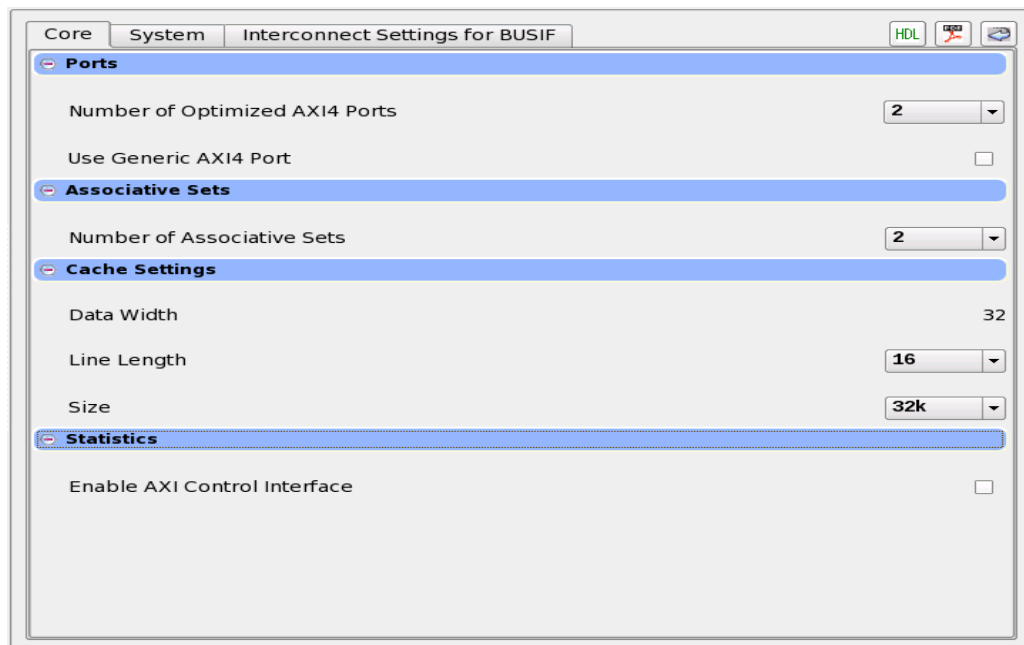

Figure 6-1: Core Parameter Tab

- **Number of Optimized AXI4 Ports** - Sets the number of optimized ports that are available to connect to a MicroBlaze™ or equivalent IP in terms of AXI4 transaction support.
- **Use Generic AXI4 Port** - Set if the Generic AXI4 port are available for IPs not adhering to the AXI4 subset required for the optimized port, such as DMA etc.

- **Number of Associative Sets** - Specify how many sets the associativity uses.
- **Data Width** - Internal data width is automatically calculated from the M_AXI interface.
- **Line Length** - System Cache cache line length is fixed to 16.
- **Size** - Sets the size of the System Cache in bytes.
- **Enable AXI Control Interface** - Set if statistics interface is available.

The system parameter tab is shown in [Figure 6-2](#) with the address parameters and S0 interface parameters visible.

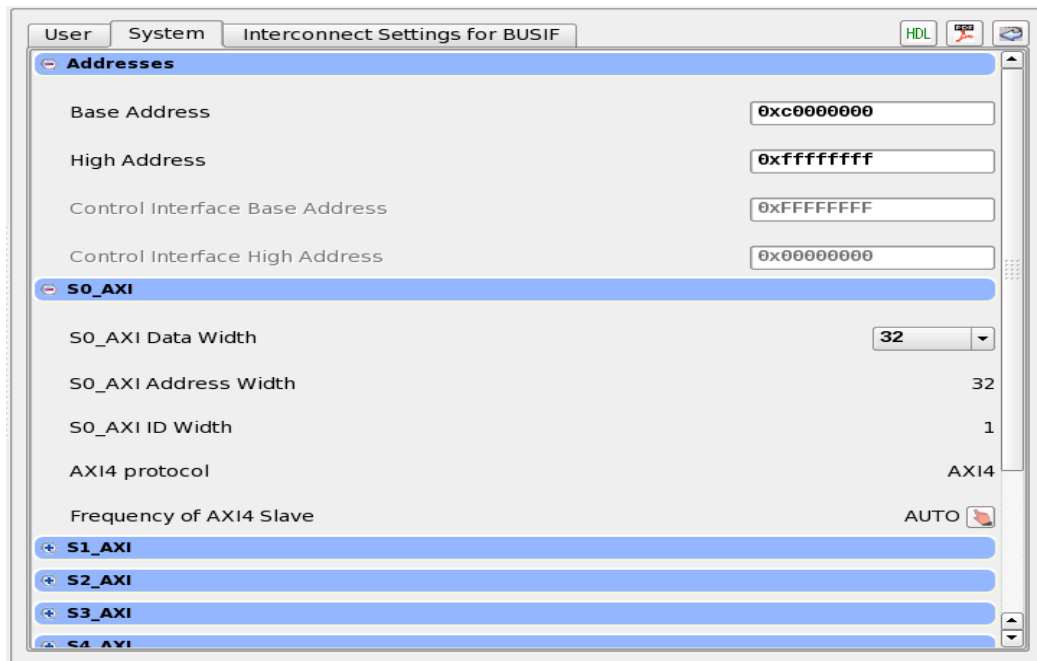

Figure 6-2: System Parameter Tab

- **Base/High Address** - Sets the address range for the cacheable area.
- **Control Interface Base/High Address** - Sets the address range for the control interface area that contains all statistics and control registers. Only available when the control interface is enabled.
- **Sx_AXI Data Width** - Sets the data width of the Optimized ports individually.
- **S0_AXI_GEN Data Width** - Sets the data width of the Generic port.
- **M_AXI Data Width** - Sets the data width of the master interface that is connected to the memory subsystem.

The interconnect parameter tab is shown in [Figure 6-3](#), showing the first few parameters.

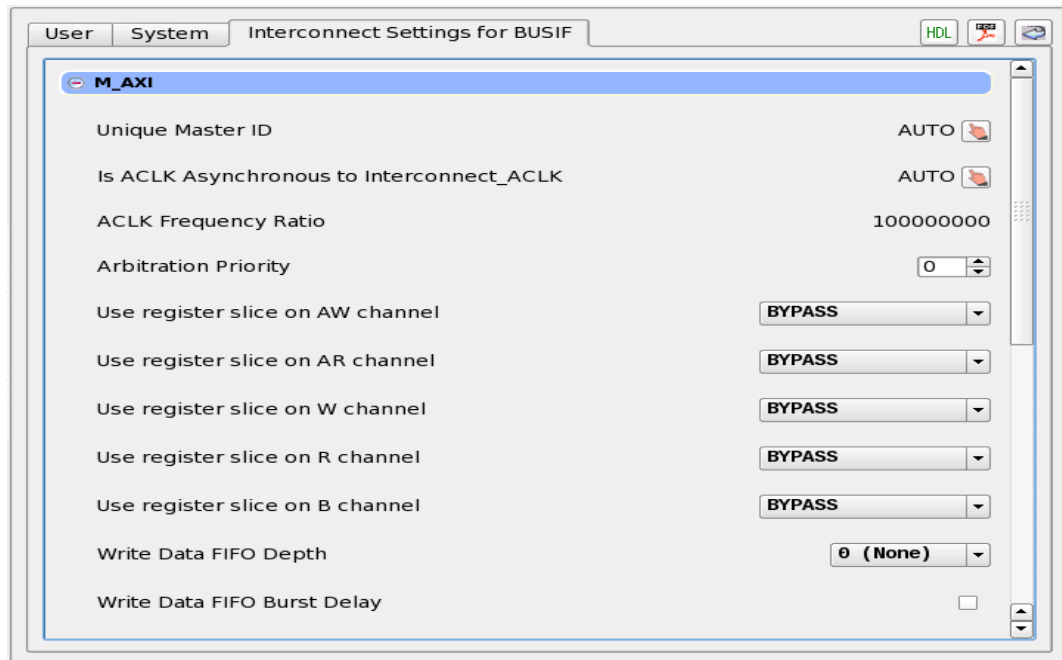

Figure 6-3: Interconnect Parameter Tab

All parameters on this tab configure how the interconnect of each AXI interface should be customized to get the desired system level performance and achieve timing closure.

Parameter Values

See [Chapter 4, Parameter Values](#).

Constraining the Core

There are no constraints associated with this core.

SECTION IV: APPENDICES

Migrating

Application Software Development

Additional Resources

Migrating

This appendix describes migrating from older versions of the IP to the current IP release.

Port Changes

No changes needed.

Functionality Changes

The supported cache sizes has been increased to support 256KB and 512KB.

Hit and miss statistics are changed to be on a per port basis instead of total.

Application Software Development

Device Drivers

There is no specific driver for System Cache; it is transparent from an application point of view.

Additional Resources

Xilinx Resources

For support resources such as Answers, Documentation, Downloads, and Forums, see the Xilinx Support website at:

www.xilinx.com/support.

For a glossary of technical terms used in Xilinx documentation, see:

www.xilinx.com/company/terms.htm.

Solution Centers

See the [Xilinx Solution Centers](#) for support on devices, software tools, and intellectual property at all stages of the design cycle. Topics include design assistance, advisories, and troubleshooting tips.

References

These documents provide supplemental material useful with this user guide:

1. AMBA AXI4-Stream Protocol [Specification](#)
2. Xilinx AMBA AXI4 Interface Protocol [webpage](#)

Technical Support

Xilinx provides technical support at www.xilinx.com/support for this LogiCORE™ IP product when used as described in the product documentation. Xilinx cannot guarantee timing, functionality, or support of product if implemented in devices that are not defined in the documentation, if customized beyond that allowed in the product documentation, or if changes are made to any section of the design labeled DO NOT MODIFY.

Revision History

The following table shows the revision history for this document.

Date	Version	Revision
04/24/12	1.0	Initial Xilinx release.
7/25/12	1.1	Updated for Vivado 2012.2, ISE 14.2. Added new supported cache sizes and improved cache statistics granularity.

Notice of Disclaimer

The information disclosed to you hereunder (the "Materials") is provided solely for the selection and use of Xilinx products. To the maximum extent permitted by applicable law: (1) Materials are made available "AS IS" and with all faults, Xilinx hereby DISCLAIMS ALL WARRANTIES AND CONDITIONS, EXPRESS, IMPLIED, OR STATUTORY, INCLUDING BUT NOT LIMITED TO WARRANTIES OF MERCHANTABILITY, NON-INFRINGEMENT, OR FITNESS FOR ANY PARTICULAR PURPOSE; and (2) Xilinx shall not be liable (whether in contract or tort, including negligence, or under any other theory of liability) for any loss or damage of any kind or nature related to, arising under, or in connection with, the Materials (including your use of the Materials), including for any direct, indirect, special, incidental, or consequential loss or damage (including loss of data, profits, goodwill, or any type of loss or damage suffered as a result of any action brought by a third party) even if such damage or loss was reasonably foreseeable or Xilinx had been advised of the possibility of the same. Xilinx assumes no obligation to correct any errors contained in the Materials or to notify you of updates to the Materials or to product specifications. You may not reproduce, modify, distribute, or publicly display the Materials without prior written consent. Certain products are subject to the terms and conditions of the Limited Warranties which can be viewed at <http://www.xilinx.com/warranty.htm>; IP cores may be subject to warranty and support terms contained in a license issued to you by Xilinx. Xilinx products are not designed or intended to be fail-safe or for use in any application requiring fail-safe performance; you assume sole risk and liability for use of Xilinx products in Critical Applications: <http://www.xilinx.com/warranty.htm#critapps>.

© Copyright 2012 Xilinx, Inc. Xilinx, the Xilinx logo, Artix, ISE, Kintex, Spartan, Virtex, Zynq, and other designated brands included herein are trademarks of Xilinx in the United States and other countries. ARM is a registered trademark of ARM in the EU and other countries. The AMBA trademark is a registered trademark of ARM Limited. All other trademarks are the property of their respective owners.

Automotive Applications Disclaimer

XILINX PRODUCTS ARE NOT DESIGNED OR INTENDED TO BE FAIL-SAFE, OR FOR USE IN ANY APPLICATION REQUIRING FAIL-SAFE PERFORMANCE, SUCH AS APPLICATIONS RELATED TO: (I) THE DEPLOYMENT OF AIRBAGS, (II) CONTROL OF A VEHICLE, UNLESS THERE IS A FAIL-SAFE OR REDUNDANCY FEATURE (WHICH DOES NOT INCLUDE USE OF SOFTWARE IN THE XILINX DEVICE TO IMPLEMENT THE REDUNDANCY) AND A WARNING SIGNAL UPON FAILURE TO THE OPERATOR, OR (III) USES THAT COULD LEAD TO DEATH OR PERSONAL INJURY. CUSTOMER ASSUMES THE SOLE RISK AND LIABILITY OF ANY USE OF XILINX PRODUCTS IN SUCH APPLICATIONS.