

Zynq UltraScale+ MPSoC Processing System v3.1

LogiCORE IP Product Guide

PG201 October 4, 2017

Table of Contents

Chapter 1: Overview

Feature Summary	5
Unsupported Features and Known Limitations	5
Licensing and Ordering	5

Chapter 2: Product Specification

Functional Description	6
Standards	19
Performance	20
Resource Utilization	20
Port Descriptions	20
Register Space	21

Chapter 3: Designing with the Core

General Design Guidelines	22
Interrupts	22
Clocking	22
Resets	23

Chapter 4: Design Flow Steps

Customizing and Generating the Core	24
PS Zynq UltraScale+ MPSoC Block Design	27
I/O Configuration	28
Clock Configuration	30
Fractional Clocking	36
DDR Configuration	37
PS-PL Configuration	40
Advanced Configuration	43
PCIe Configuration	46
Isolation Configurations	47
User Parameters	54
Output Generation	55
Constraining the Core	55
Simulation	56
Synthesis and Implementation	56

Chapter 5: Example Design

Appendix A: Upgrading

Upgrading in the Vivado Design Suite	65
--	----

Appendix B: Port Descriptions

Appendix C: User Parameters

Appendix D: Debugging

Finding Help on Xilinx.com	194
Documentation	194
Solution Centers	194
Answer Records	195
Technical Support	195

Appendix E: Additional Resources and Legal Notices

Xilinx Resources	196
Documentation Navigator and Design Hubs	196
References	197
Revision History	198
Notice of Disclaimer	200

Introduction

The Xilinx® Zynq® UltraScale+™ Processing System LogiCORE™ IP core is the software interface around the Zynq UltraScale+ Processing System. The Zynq UltraScale+ MPSoC family consists of a system-on-chip (SoC) style integrated processing system (PS) and a Programmable Logic (PL) unit, providing an extensible and flexible SoC solution on a single die.

Features

- Enable/Disable I/O Peripherals (IOP)
- Enable/Disable AXI Interfaces
- Multiplexed I/O (MIO) Configuration
- Extended Multiplexed I/Os (EMIO)
- PL Clocks and Interrupts, resets
- PS internal clocking
- Generation of System Level Configuration Registers (SLCRs)
- High Speed SerDes Configuration
- PS DDR Configuration
- Isolation Configuration

LogiCORE IP Facts Table	
Core Specifics	
Supported Device Family ⁽¹⁾	Zynq UltraScale+ MPSoC
Supported User Interfaces	Not Applicable
Resources	Not Applicable
Provided with Core	
Design Files	Verilog
Example Design	See Chapter 5, Example Design .
Test Bench	Not Provided
Constraints File	Not Provided
Simulation Model	Not Provided
Supported S/W Driver	N/A
Tested Design Flows⁽²⁾	
Design Entry	Vivado® Design Suite
Simulation	Not Applicable
Synthesis	Vivado Synthesis
Support	
Provided by Xilinx @ Xilinx Support web page	

Notes:

1. For a complete list of supported devices, see Vivado IP catalog.
2. For the supported versions of the tools, see the [Xilinx Design Tools: Release Notes Guide](#).

Overview

The Zynq® UltraScale+™ MPSoC family is based on the Xilinx® All Programmable system-on-chip (AP MPSoC) architecture. The Zynq UltraScale+ Processing System core acts as a logic connection between the PS and the Programmable Logic (PL) while assisting you to integrate customized and integrated IP cores with the processing system using the Vivado® IP integrator.

For a detailed overview of the core, see [Chapter 2, Product Specification](#).

Feature Summary

See [Features](#) on the IP Facts page.

Unsupported Features and Known Limitations

The core provides a Vivado Integrated Design Environment (Vivado IDE) configuration of the PS instance and its I/O. Due to the flexibility of the PS, only the most common features, I/O configurations, and peripheral settings are configured by this core. Additional register settings might be necessary by your own register accesses.

Xilinx frequently updates the list of known issues each release, for the most up to date information always access the master Answer Record [66183](#), *Zynq UltraScale+ MPSoC Processing System IP - Release Notes and Known Issues*.

Licensing and Ordering

This Xilinx® LogiCORE™ IP module is provided at no additional cost with the Xilinx® Vivado Design Suite under the terms of the [Xilinx End User License](#). Information about this and other Xilinx® LogiCORE IP modules is available at the [Xilinx Intellectual Property](#) page. For information about pricing and availability of other Xilinx LogiCORE IP modules and tools, contact your [local Xilinx sales representative](#).

For more information, visit the [Zynq UltraScale+ MPSoC Processing System IP product page](#).

Product Specification

Functional Description

The Zynq® UltraScale+™ MPSoC Processing System wrapper instantiates the processing system section of the Zynq UltraScale+ MPSoC for the programmable logic and external board logic. The wrapper includes unaltered connectivity and some logic functions for some signals. For a description of the architecture of the processing system, see the *Zynq UltraScale All Programmable MPSoC Technical Reference Manual (UG1085)* [Ref 1].

Figure 2-1 shows the architecture of Processing System (PS) IP wrapper.

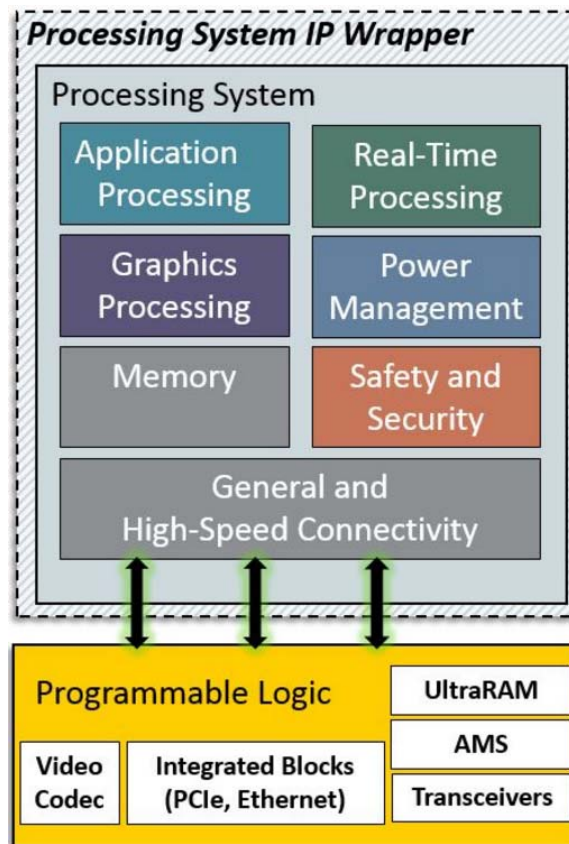

Figure 2-1: PS IP Wrapper Architecture

The core connects the interface signals with the rest of the embedded system in the programmable logic. The interfaces between the processing system and programmable logic mainly consist of three main groups: the extended multiplexed I/O (EMIO), programmable logic I/O, and the AXI I/O groups. The PS Configuration Wizard (PCW) configures the Zynq UltraScale+ MPSoC Processing System Core. Double click PS IP on the Vivado® IPI (Inter-Process Interrupts) canvas to access the PCW. [Figure 2-2](#) shows the PCW configuration on Zynq UltraScale+ MPSoC Processing System. The core performs the functions described in the following subsections.

[Figure 2-2](#) shows a top-level block diagram.

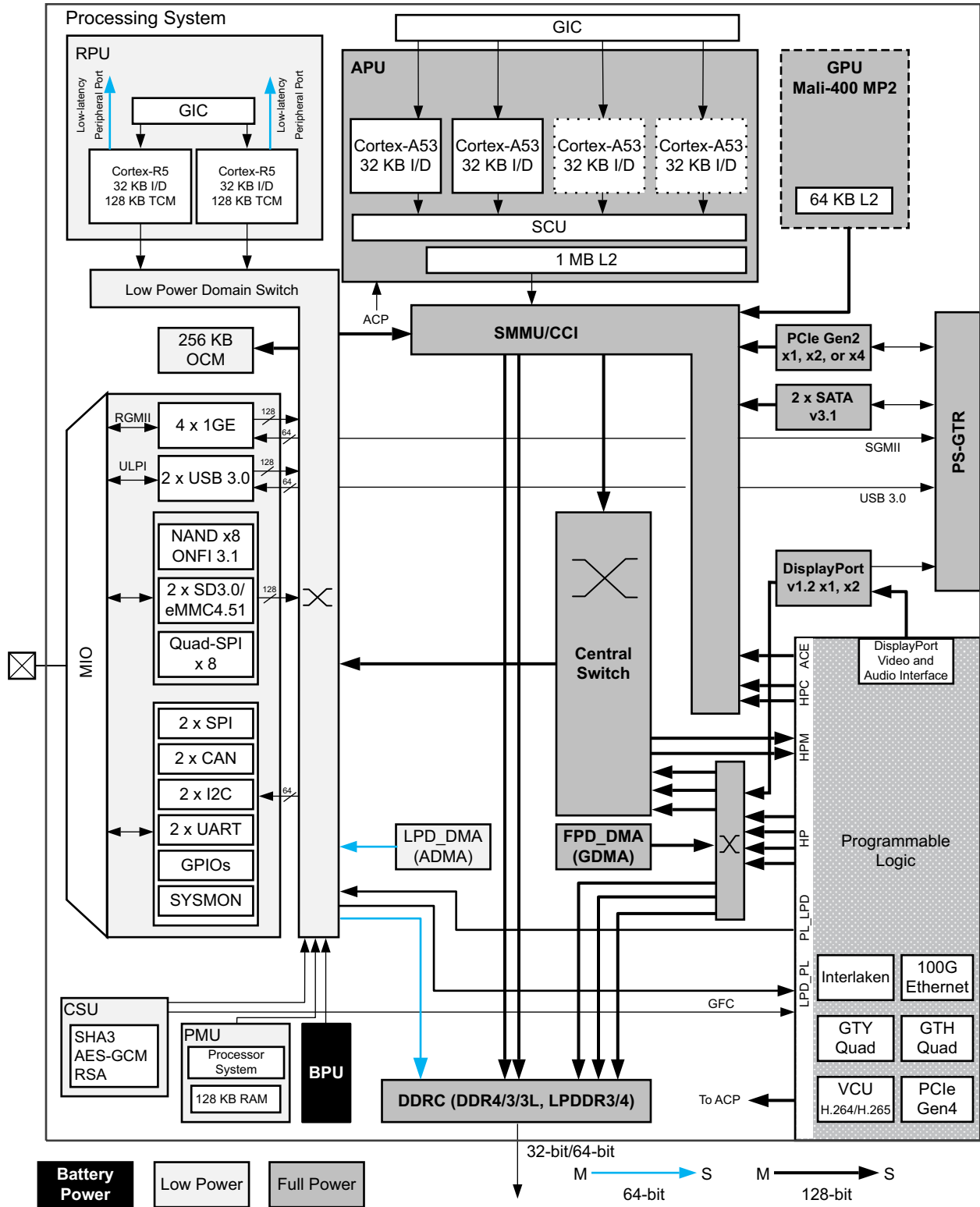

Figure 2-2: Zynq UltraScale+ MPSoC Top Level Block Diagram

Connectivity

ddr, mio, por/clock/srst ports are unaltered.

- fclk are also made of individual signals instead of the array FCLKCLK (3:0).
- PS PL IRQ are made of individual signals ps_pl_irq_can0, ps_pl_irq_can1, ps_pl_irq_enet0, ps_pl_irq_enet1, ps_pl_irq_enet2, ps_pl_irq_enet3, ps_pl_irq_enet0_wake0, ps_pl_irq_enet0_wake1, ps_pl_irq_enet0_wake2, ps_pl_irq_enet0_wake3, ps_pl_irq_gpio, ps_pl_irq_i2c0, ps_pl_irq_i2c1, ps_pl_irq_uart0, ps_pl_irq_uart1, ps_pl_irq_sdio0, ps_pl_irq_sdio1, ps_pl_irq_sdio0_wake, ps_pl_irq_sdio1_wake, ps_pl_irq_spi0, ps_pl_irq_spi1, ps_pl_irq_qspi, ps_pl_irq_ttc0_0, ps_pl_irq_ttc0_1, ps_pl_irq_ttc0_2, ps_pl_irq_ttc1_0, ps_pl_irq_ttc1_1, ps_pl_irq_ttc1_2, ps_pl_irq_ttc2_0, ps_pl_irq_ttc2_1, ps_pl_irq_ttc2_2, ps_pl_irq_ttc3_0, ps_pl_irq_ttc3_1, ps_pl_irq_ttc3_2, ps_pl_irq_csu_pmu_wdt, ps_pl_irq_lp_wdt, ps_pl_irq_usb3_0_endpoint, ps_pl_irq_usb3_0_otg, ps_pl_irq_usb3_1_endpoint, ps_pl_irq_usb3_1_otg, ps_pl_irq_adma⁽¹⁾_chan, ps_pl_irq_usb3_0_pmu_wakeup, ps_pl_irq_gdma⁽²⁾_chan, ps_pl_irq_csu, ps_pl_irq_csu_dma, ps_pl_irq_efuse, ps_pl_irq_xmpu_lpd, ps_pl_irq_ddr_ss, ps_pl_irq_nand, ps_pl_irq_fp_wdt, ps_pl_irq_pcie_msi, ps_pl_irq_pcie_legacy, ps_pl_irq_pcie_dma, ps_pl_irq_pcie_msc, ps_pl_irq_dport, ps_pl_irq_fpd_apb_int, ps_pl_irq_fpd_atb_error, ps_pl_irq_dpdma, ps_pl_irq_apm_fpd, ps_pl_irq_gpu, ps_pl_irq_sata, ps_pl_irq_xmpu_fpd, ps_pl_irq_apu_cpumnt, ps_pl_irq_apu_cti, ps_pl_irq_apu_pmu, ps_pl_irq_apu_comm, ps_pl_irq_apu_l2err, ps_pl_irq_apu_exterr, ps_pl_irq_apu_regs, ps_pl_irq_intf_ppd_cci, ps_pl_irq_intf_fpd_smmu, ps_pl_irq_atb_err_lpd, ps_pl_irq_aib_axi, ps_pl_irq_ams, ps_pl_irq_lpd_apm, ps_pl_irq_rtc_alararm, ps_pl_irq_rtc_seconds, ps_pl_irq_clkmon, ps_pl_irq_ipi_channel0, ps_pl_irq_ipi_channel1, ps_pl_irq_ipi_channel2, ps_pl_irq_ipi_channel7, ps_pl_irq_ipi_channel8, ps_pl_irq_ipi_channel9, ps_pl_irq_ipi_channel10, ps_pl_irq_rpu_pm, ps_pl_irq_ocm_error, ps_pl_irq_lpd_apb_intr, ps_pl_irq_r5_core0_ecc_error, and ps_pl_irq_r5_core1_ecc_error.
- spi or spi* sson are made of individual signals spi*_ss2_o, spi*_ss1_o, and spi*_ss_o.

Notes:

1. ADMA is also referenced as LPD_DMA throughout this guide. These two terms are synonymous.
2. GDMA is also referenced as FPD_DMA throughout this guide. These two terms are synonymous.

I/O Peripherals

I/O Peripherals (IOP) include the following.

- Quad serial peripheral interface (SPI) flash memory
- NAND flash
- UART
- I2C

- SPI flash memory
- Secure Digital Input Output (SDIO)
- general purpose I/O (GPIO)
- controller area network (CAN)
- USB
- Ethernet

The interfaces for these I/O peripherals (IOPs) can be routed to MIO ports and the extended multiplexed I/O (EMIO) interfaces as described in the *Zynq UltraScale All Programmable MPSoC Technical Reference Manual* (UG1085) [Ref 1].

- Low power domain (LPD) peripherals available in PS:
 - 4 X Gigabit Ethernet
 - 2 X USB3
 - 2 X SDIO
 - 2 X SPI
 - 2 X CAN
 - 2 X I2C
 - 2 X UART
 - NAND Controller
 - Quad SPI flash memory
 - Controller, GPIOs
 - System Monitor
- Full power domain (FPD) peripherals available in PS:
 - PCIe® Gen2
 - 2 X Serial Advanced Technology Attachment (SATA)
 - Display Port V1.2

MIO Ports

The Zynq UltraScale+ MPSoC design tools are used to configure the core MIO ports. There are up to 78 MIO ports available from the processing system. The wizard allows you to choose the peripheral ports to be connected to MIO ports.

Extended MIO Ports

Because there are only up to 78 MIO available ports, many peripheral I/O ports beyond these can still be routed to the programmable logic through the Extended MIO (EMIO) interface. Alternative routing for IOP interfaces through programmable logic enables you to take full advantage of the IOP available in the processing system.

The EMIO for I2C, SPI flash memory, Ethernet management data input/output (MDIO), ARM® JTAG (PJTAG), SDIO, GPIO 3-state enable signals are inverted in the Zynq UltraScale+ MPSoC Processing System core.

The Zynq UltraScale+ MPSoC Processing System core allows you to select GPIO up to 96 bits. The Zynq UltraScale+ MPSoC Processing System has control logic to adjust user-selected width to flow into processing system.

See [MIO Voltage Standard in Chapter 4](#).

AXI4 I/O Compliant Interfaces

Following are the AMBA® AXI4 compliant interfaces:

- Three PS General Purpose Master interfaces user configurable as 32, 64, and 128 bits in width. The default width is 128.
- Seven PL General Purpose Master interfaces user configurable as 32, 64, and 128 bits in width. The default width is 128.
- A 128-bit PL Master AXI coherency extension (ACE) interface for coherent I/O to A53 L1 and L2 cache systems
- A 128-bit PL Master ACP interface to support L2 cache allocation from PL masters. Limited to 64-byte cache line transfers only

See [PS-PL Configuration in Chapter 4](#).

Logic for Vivado Design Suite IP - Processing System Interface

The Zynq UltraScale+ MPSoC Processing System core allows you to add Vivado® IP cores in the programmable logic to interface with the processing system. Custom direct memory access (DMA) functions can be implemented in the PL to oversee data movement irrespective of the processor intervention.

Programmable Logic Clocks and Interrupts

The interrupts from the processing system I/O peripherals (IOP) are routed to the PL and assert asynchronously to the `clk` clocks.

The PL can asynchronously assert up to 20 interrupts to the PS.

- 16 interrupt signals are mapped to the interrupt controller as a peripheral interrupt where each interrupt signal is set to a priority level and mapped to one or both of the CPUs. To use more than one interrupt signal, use a Concat block in the Vivado IP integrator to automatically size the width of the interrupt vector.
- The remaining four PL interrupt signals are inverted and routed to the `nFIQ` and `nIRQ` interrupt directly to the signals to the private peripheral interrupt (PPI) unit of the interrupt controller. There is an `nFIQ` and `nIRQ` interrupt for each of two CPUs.

The PS to PL, and PL to PS interrupts are listed in [Table 2-2](#). For details on the interrupt signals, see the Interrupts chapter in the *Zynq UltraScale All Programmable MPSoC Technical Reference Manual* (UG1085) [[Ref 1](#)].

See [PS-PL Configuration in Chapter 4](#) for Vivado Design Suite implementation.

Table 2-1: Pin mapping to Interrupt IDs

Interrupt ID	Pin
121	pl_ps_irq0 [0]
122	pl_ps_irq0 [1]
123	pl_ps_irq0 [2]
124	pl_ps_irq0 [3]
125	pl_ps_irq0 [4]
126	pl_ps_irq0 [5]
127	pl_ps_irq0 [6]
128	pl_ps_irq0 [7]
137	pl_ps_irq1 [0]
138	pl_ps_irq1 [1]
139	pl_ps_irq1 [2]
140	pl_ps_irq1 [3]
141	pl_ps_irq1 [4]
142	pl_ps_irq1 [5]
143	pl_ps_irq1 [6]
144	pl_ps_irq1 [7]

Table 2-2: Interrupt Map for PS Configuration Wizard (PCW)

S.No	Interrupt ID	Interrupt Name	Description	Type
PL-PS Interrupts (Interrupts that go from PL to PS)				
1	121-128, 136-143 (See Table 2-1 for Pin mapping to each interrupt ID)	IRQ-F2P[15:0]	Shared Interrupts from PL logic to GICs of real-time processing unit (RPU) or application processing unit (APU)	Shared Interrupts
2	31	A53-Core_0 nIRQ	Cortex™ A53 Core0 Private Peripheral Legacy IRQ Interrupt	Private Peripheral Interrupt
3	31	A53-Core_1 nIRQ	Cortex A53 Core1 Private Peripheral Legacy IRQ Interrupt	Private Peripheral Interrupt
4	31	A53-Core_2 nIRQ	Cortex A53 Core2 Private Peripheral Legacy IRQ Interrupt	Private Peripheral Interrupt
5	31	A53-Core_3 nIRQ	Cortex A53 Core3 Private Peripheral Legacy IRQ Interrupt	Private Peripheral Interrupt
6	28	A53-Core_0 nFIQ	Cortex A53 Core0 Private Peripheral Legacy FIQ Interrupt	Private Peripheral Interrupt
7	28	A53-Core_1 nFIQ	Cortex A53 Core1 Private Peripheral Legacy FIQ Interrupt	Private Peripheral Interrupt
8	28	A53-Core_2 nFIQ	Cortex A53 Core2 Private Peripheral Legacy FIQ Interrupt	Private Peripheral Interrupt
9	28	A53-Core_3 nFIQ	Cortex A53 Core3 Private Peripheral Legacy FIQ Interrupt	Private Peripheral Interrupt
PS -PL Interrupts (Interrupts coming from PS to PL)				
1	1	IRQ_P2F_RPU Performance Monitor 0	RPU Performance Monitor 0 Interrupt	Shared Interrupt
2	1	IRQ_P2F_RPU Performance Monitor 1	RPU Performance Monitor 1 Interrupt	Shared Interrupt
3	1	IRQ_P2F_OCM Error	On-chip RAM (OCM) Error Interrupt	Shared Interrupt
4	1	IRQ_P2F_LPD APB Interrupts	OR of all AMBA peripheral bus (APB) interrupts from LPD. Refer to the technical reference manual for APB Interrupt and Register Information.	Shared Interrupt

Table 2-2: Interrupt Map for PS Configuration Wizard (PCW) (Cont'd)

S.No	Interrupt ID	Interrupt Name	Description	Type
5	1	IRQ_P2F_R5 Core0_ECC_Error	RPU CPU0 error-correction code (ECC) errors interrupt. All ECC interrupts of CPU0 are combined into this interrupt.	Shared Interrupt
6	1	IRQ_P2F_R5 Core1_ECC_Error	RPU CPU1 ECC errors interrupt. All ECC interrupts of CPU1 are combined into this interrupt.	Shared Interrupt
7	1	IRQ_P2F_NAND	NAND/NOR/SRAM Static Memory Controller Interrupt	Shared Interrupt
8	1	IRQ_P2F_QSPI	SPI flash memory interrupt	Shared Interrupt
9	1	IRQ_P2F_GPIO	GPIO interrupt	Shared Interrupt
10	1	IRQ_P2F_I2C0	I2C0 interrupt	Shared Interrupt
11	1	IRQ_P2F_I2C1	I2C1 interrupt	Shared Interrupt
12	1	IRQ_P2F_SPI0	SPI0 interrupt	Shared Interrupt
13	1	IRQ_P2F_SPI1	SPI1 interrupt	Shared Interrupt
14	1	IRQ_P2F_UART0	UART0 interrupt	Shared Interrupt
15	1	IRQ_P2F_UART1	UART1 interrupt	Shared Interrupt
16	1	IRQ_P2F_CAN0	CAN0 interrupt	Shared Interrupt
17	1	IRQ_P2F_CAN1	CAN1 interrupt	Shared Interrupt
18	1	IRQ_P2F_LPD_APM	Or of all LPD AXI performance monitors (APMs)	Shared Interrupt
19	1	IRQ_P2F_RTC_ALARM	RTC Alarm Interrupt	Shared Interrupt
20	1	IRQ_P2F_RTC_SECONDS	RTC Seconds Interrupt	Shared Interrupt
21	1	IRQ_P2F_CLKMON	Clock monitor coming from CRL	Shared Interrupt
22	1	S_PL_IRQ_IPI_CHANNEL0	OR' of all of inter-processor interrupt (IPIs) targeted to IPI channel 0	Shared Interrupt
23	1	S_PL_IRQ_IPI_CHANNEL1	OR' of all of inter-processor interrupt (IPIs) targeted to IPI channel 1	Shared Interrupt

Table 2-2: Interrupt Map for PS Configuration Wizard (PCW) (Cont'd)

S.No	Interrupt ID	Interrupt Name	Description	Type
24	1	S_PL_IRQ_IPI_CHANNEL2	OR' of all of inter-processor interrupt (IPIs) targeted to IPI channel 2	Shared Interrupt
25	1	S_PL_IRQ_IPI_CHANNEL7	OR' of all of inter-processor interrupt (IPIs) targeted to IPI channel 7	Shared Interrupt
26	1	S_PL_IRQ_IPI_CHANNEL8	OR' of all of inter-processor interrupt (IPIs) targeted to IPI channel 8	Shared Interrupt
27	1	S_PL_IRQ_IPI_CHANNEL9	OR' of all of inter-processor interrupt (IPIs) targeted to IPI channel 9	Shared Interrupt
28	1	S_PL_IRQ_IPI_CHANNEL10	OR' of all of inter-processor interrupt (IPIs) targeted to IPI channel 10	Shared Interrupt
29	1	IRQ_P2F_TTC0_0	Triple Timer 0 Counter 0 Interrupt	Shared Interrupt
30	1	IRQ_P2F_TTC0_1	Triple Timer 0 Counter 1 Interrupt	Shared Interrupt
31	1	IRQ_P2F_TTC0_2	Triple Timer 0 Counter 2 Interrupt	Shared Interrupt
32	1	IRQ_P2F_TTC1_0	Triple Timer 1 Counter 0 Interrupt	Shared Interrupt
33	1	IRQ_P2F_TTC1_1	Triple Timer 1 Counter 1 Interrupt	Shared Interrupt
34	1	IRQ_P2F_TTC1_2	Triple Timer 1 Counter 2 Interrupt	Shared Interrupt
35	1	IRQ_P2F_TTC2_0	Triple Timer 2 Counter 0 Interrupt	Shared Interrupt
36	1	IRQ_P2F_TTC2_1	Triple Timer 2 Counter 1 Interrupt	Shared Interrupt
37	1	IRQ_P2F_TTC2_2	Triple Timer 2 Counter 2 Interrupt	Shared Interrupt
38	1	IRQ_P2F_TTC3_0	Triple Timer 3 Counter 0 Interrupt	Shared Interrupt
39	1	IRQ_P2F_TTC3_1	Triple Timer 3 Counter 1 Interrupt	Shared Interrupt
40	1	IRQ_P2F_TTC3_2	Triple Timer 3 Counter 2 Interrupt	Shared Interrupt
41	1	IRQ_P2F_SDIO0	SDIO0 interrupt	Shared Interrupt
42	1	IRQ_P2F_SDIO1	SDIO1 interrupt	Shared Interrupt
43	1	IRQ_P2F_SDIO0_wake	SDIO0 wake interrupt	Shared Interrupt

Table 2-2: Interrupt Map for PS Configuration Wizard (PCW) (Cont'd)

S.No	Interrupt ID	Interrupt Name	Description	Type
44	1	IRQ_P2F_SDIO1_wake	SDIO1 wake interrupt	Shared Interrupt
45	1	IRQ_P2F_LP_WDT	Watchdog timer (WDT) in the LPD (IOU) (IOU is Input Output Unit)	Shared Interrupt
46	1	IRQ_P2F_CSUPMU_WDT	WDT in the Configuration Security Unit Performance monitoring unit (CSUPMU)	Shared Interrupt
47	1	IRQ_P2F_ATB Err LPD	AMBA trace bus (ATB) interrupt	Shared Interrupt
48	1	IRQ_P2F_AIB_AXI	AXI Isolation Block (AIB) AXI interrupt	Shared Interrupt
49	1	IRQ_P2F_AMS	Analog mixed-signal unit (AMS) interrupt	Shared Interrupt
50	1	IRQ_P2F_GigabitEth0	Ethernet0 interrupt	Shared Interrupt
51	1	IRQ_P2F_GigabitEth_Wake0	Ethernet0 wake-up interrupt	Shared Interrupt
52	1	IRQ_P2F_GigabitEth1	Gigabit Ethernet1 interrupt	Shared Interrupt
53	1	IRQ_P2F_GigabitEth_wakeup1	Gigabit Ethernet1 wake-up interrupt	Shared Interrupt
54	1	IRQ_P2F_GigabitEth2	Gigabit Ethernet2 interrupt	Shared Interrupt
55	1	IRQ_P2F_GigabitEth2_wakeup	Gigabit Ethernet2 wake-up interrupt	Shared Interrupt
56	1	IRQ_P2F_GigabitEth3	Gigabit Ethernet3 interrupt	Shared Interrupt
57	1	IRQ_P2F_GigabitEth3_wake up	Gigabit Ethernet3 wake-up interrupt	Shared Interrupt
58	4	IRQ_P2F_USB3_0_Endpoint	USB3_0 Endpoint related interrupts. Four Interrupts Enabled. One interrupt each for Bulk, Isochronous, Interrupt and Control type.	Shared Interrupt
59	1	IRQ_P2F_USB3_0_OTG	USB3_0 OTG interrupt	Shared Interrupt
60	4	IRQ_P2F_USB3_1_Endpoint	USB3_1 Endpoint related interrupts. Four Interrupts Enabled. One interrupt each for Bulk, Isochronous, Interrupt and Control type.	Shared Interrupt
61	1	IRQ_P2F_USB3_1_OTG	USB3_1 OTG interrupt	Shared Interrupt
62	1	IRQ_P2F_USB3_0_1 PMU_WAKEUP	Bit 0 is wake up from USB3_0 to power monitoring unit (PMU) while bit 1 is wake up from USB3_1 to PMU	Shared Interrupt

Table 2-2: Interrupt Map for PS Configuration Wizard (PCW) (Cont'd)

S.No	Interrupt ID	Interrupt Name	Description	Type
63	1	IRQ_P2F_ADMA ⁽¹⁾ _Chan_0	LPD_DMA(ADMA) channel 0 interrupt	Shared Interrupt
64	1	IRQ_P2F_ADMA ⁽¹⁾ _Chan_1	LPD_DMA(ADMA) channel 1 interrupt	Shared Interrupt
65	1	IRQ_P2F_ADMA ⁽¹⁾ _Chan_2	LPD_DMA(ADMA) channel 2 interrupt	Shared Interrupt
66	1	IRQ_P2F_ADMA ⁽¹⁾ _Chan_3	LPD_DMA(ADMA) channel 3 interrupt	Shared Interrupt
67	1	IRQ_P2F_ADMA ⁽¹⁾ _Chan_4	LPD_DMA(ADMA) channel 4 interrupt	Shared Interrupt
68	1	IRQ_P2F_ADMA ⁽¹⁾ _Chan_5	LPD_DMA(ADMA) channel 5 interrupt	Shared Interrupt
69	1	IRQ_P2F_ADMA ⁽¹⁾ _Chan_6	LPD_DMA(ADMA) channel 6 interrupt	Shared Interrupt
70	1	IRQ_P2F_ADMA ⁽¹⁾ _Chan_7	LPD_DMA(ADMA) channel 7 interrupt	Shared Interrupt
71	1	IRQ_P2F_CSU	Device Configuration Module Interrupt	Shared Interrupt
72	1	IRQ_P2F_CSU_DMA	DMA for Configuration and Security Unit (CSU) interrupt	Shared Interrupt
73	1	IRQ_P2F_EFUSE	EFUSE interrupt	Shared Interrupt
74	1	IRQ_P2F_XMPU_LPD	Xilinx memory protection unit (XMPU) error Interrupt for OCM and LPD peripherals	Shared Interrupt
75	1	IRQ_P2F_DDR_SS	DDR controller subsystem interrupt	Shared Interrupt
76	1	IRQ_P2F_FP_WDT	Top Level Watch Dog Timer Interrupt.	Shared Interrupt
77	1	IRQ_P2F_PCIE_MSI	PCIE_MSI[0]=PCIe interrupt for MSI vectors 31 to 0 PCIE_MSI[1]=PCIe interrupt for MSI vectors 63 to 32	Shared Interrupt
78	1	IRQ_P2F_PCIE_Legacy	PCIE legacy (INTA/BC/D) interrupts	Shared Interrupt
79	1	IRQ_P2F_PCIE_DMA	PCIE Bridge DMA interrupts	Shared Interrupt
80	1	IRQ_P2F_PCIE_MSC	PCIE misc (error etc) interrupts	Shared Interrupt
81	1	IRQ_P2F_DPORT	Display port general purpose interrupt	Shared Interrupt
82	1	IRQ_P2F_FPD_APB_INT	OR'd of all APB interrupts from LPD	Shared Interrupt

Table 2-2: Interrupt Map for PS Configuration Wizard (PCW) (Cont'd)

S.No	Interrupt ID	Interrupt Name	Description	Type
83	1	IRQ_P2F_FPD ATB Error	ATB interrupt for FPD	Shared Interrupt
84	1	IRQ_P2F_DPDMA interrupt	DPDMA interrupt	Shared Interrupt
85	1	IRQ_P2F_APM FPD	Or of all APMs for FPD	Shared Interrupt
86	1	IRQ_P2F_GDMA ⁽²⁾ _Chan_0	Interrupt from general purpose (FPD_DMA(GDMA)) Channel 0	Shared Interrupt
87	1	IRQ_P2F_GDMA ⁽²⁾ _Chan_1	Interrupt from FPD_DMA(GDMA) Channel 1	Shared Interrupt
88	1	IRQ_P2F_GDMA ⁽²⁾ _Chan_2	Interrupt from FPD_DMA(GDMA) Channel 2	Shared Interrupt
89	1	IRQ_P2F_GDMA ⁽²⁾ _Chan_3	Interrupt from FPD_DMA(GDMA) Channel 3	Shared Interrupt
90	1	IRQ_P2F_GDMA ⁽²⁾ _Chan_4	Interrupt from FPD_DMA(GDMA) Channel 4	Shared Interrupt
91	1	IRQ_P2F_GDMA ⁽²⁾ _Chan_5	Interrupt from FPD_DMA(GDMA) Channel 5	Shared Interrupt
92	1	IRQ_P2F_GDMA ⁽²⁾ _Chan_6	Interrupt from FPD_DMA(GDMA) Channel 6	Shared Interrupt
93	1	IRQ_P2F_GDMA ⁽²⁾ _Chan_7	Interrupt from FPD_DMA(GDMA) Channel 7	Shared Interrupt
94	1	IRQ_P2F_GPU	All of GPU interrupts are OR-ed together	Shared Interrupt
95	1	IRQ_P2F_SATA	SATA controller interrupt	Shared Interrupt
96	1	IRQ_P2F_XMPU FPD	Xilinx memory protection unit (XMPU) error Interrupt for DDR and FPD peripherals	Shared Interrupt
97	4	IRQ_P2F_APU_CPUMNT	VCPUMT	Shared Interrupt
98	4	IRQ_P2F_APU_CTI	Cross trigger interface (CTI)	Shared Interrupt
99	4	IRQ_P2F_APU_PMU	Performance Monitor Unit Interrupt	Shared Interrupt
100	4	IRQ_P2F_APU_COMM	APU Communication Error	Shared Interrupt
101	1	IRQ_P2F_APU_L2ERR	L2 Cache	Shared Interrupt
102	1	IRQ_P2F_APU_EXTERR	EXTERR	Shared Interrupt

Table 2-2: Interrupt Map for PS Configuration Wizard (PCW) (Cont'd)

S.No	Interrupt ID	Interrupt Name	Description	Type
103	1	IRQ_P2F_APU_REGS	REGISTER Interrupt	Shared Interrupt
104	1	IRQ_P2F_INTF_PPD_CCI	Cache coherent interconnect (CCI) Interrupt from FPD	Shared Interrupt
105	1	IRQ_P2F_INTF_FPD_SMMU	System Memory Management Unit (SMMU) Interrupt from FPD	Shared Interrupt

Notes:

1. ADMA is also referenced as LPD_DMA throughout this guide. These two terms are synonymous.
2. GDMA is also referenced as FPD_DMA throughout this guide. These two terms are synonymous.

The Zynq UltraScale+ MPSoC Processing System core employs logic to handle PL interrupts, the number which varies from 1 to 16 depending on your selection. The number of interrupts connected to IRQ_F2P are calculated and the logic ensures the correct order of an interrupt assignment.

The Zynq UltraScale+ MPSoC Processing System interrupts from IOPs are available to custom master interfaces in PL.

PL Clocks

The Zynq UltraScale+ MPSoC Processing System provides four clocks to the PL. Zynq UltraScale+ MPSoC Processing System enables configuration of these clocks to be used in the PL. Zynq UltraScale+ MPSoC Processing System inserts a BUFG for each of the PL clocks through parameters similar to C_FCLK_CLK0_BUF. Programmable Logic clocks are configured for 99.99 MHz by default.

Standards

The Zynq UltraScale+ MPSoC Processing System core is compatible with the AXI4 Interface. AXI interfaces can be used by an AXI4-compliant master or slave connected to the ARM core.

See the "Interconnect" chapter in the *Zynq UltraScale All Programmable MPSoC Technical Reference Manual* (UG1085) [Ref 1].

Performance

For information, see the “PL and Memory System Performance Overview” section in the “Programmable Logic Design Guide” chapter of the *Zynq UltraScale All Programmable MPSoC Technical Reference Manual* (UG1085) [Ref 1].

Maximum Frequencies

For information, see the *Zynq UltraScale All Programmable MPSoC Technical Reference Manual* (UG1085) [Ref 1]

Latency

For information, see the *Zynq UltraScale All Programmable MPSoC Technical Reference Manual* (UG1085) [Ref 1]

Throughput

For information, see the *Zynq UltraScale All Programmable MPSoC Technical Reference Manual* (UG1085) [Ref 1]

Power

For information, see the *Zynq UltraScale All Programmable MPSoC Technical Reference Manual* (UG1085) [Ref 1]

Resource Utilization

Zynq UltraScale+ MPSoC is a hard IP core so this section does not apply to this core.

Port Descriptions

See [Appendix B, Port Descriptions](#) for all of the tables.

Register Space

Note: For register information, see the *Zynq UltraScale+ MPSoC Register Reference User Guide* (UG1087) [Ref 2].

The Zynq UltraScale+ MPSoC Processing System core provides access from PL masters to PS internal peripherals, and memory through AXI FIFO interface (AFI) interfaces. The Vivado IP integrator address editor provides various address segments with a fixed address for each slave interface. The availability of the address segments is controlled through the following addressing parameters.

- **Detailed IOP address space:** Provides individual address spaces for PS internal peripherals.
- **Allow access to PS/SLCR registers:** Allows address mapping to PS and system level control registers (SLCR) register space.
- **Detailed PS/SLCR address space:** Provides individual address spaces for PS/SLCR registers.

The PS address space accessible from the PL consists of DDR, OCM, static memory controller (SMC) memories, SLCR registers, PS I/O peripheral registers, and PS system registers. For more information, see the “System Addresses” chapter of the *Zynq UltraScale All Programmable MPSoC Technical Reference Manual* (UG1085) [Ref 1].

Designing with the Core

This chapter includes guidelines and additional information to facilitate designing with the core.

General Design Guidelines

There are three interfaces through which the Zynq® UltraScale+™ Processing System core can access the PL side peripherals and vice versa. For more details, see the individual sections of AXI_HP and AXI_ACP interfaces in the “Interconnect” chapter of the *Zynq UltraScale All Programmable MPSoC Technical Reference Manual* (UG1085) [Ref 1].

Interrupts

To connect multiple interrupts in IP integrator, use a concat block to merge the individual signals together before connecting to the core. The interrupt port will be automatically expanded to match the resulting output with the concat block.

Clocking

There are four clock groups.

- Main Clock Group (MCG). This group has five PLLs.
 - I/O PLL
 - RPU PLL
 - APU PLL
 - DDR PLL
 - Video PLL

- Secure Clock Group (SCG). This group has two PLLs.
 - eFuse
 - PMU
- RTC Clock Group (RCG). This is Real Time Clock, a dedicated internal clock for RTC. The RTC clock group (RCG) provides a 32 KHZ clock to the RTC in the battery power domain (BPU). It is an extremely small clock domain compared with the other two clock groups. There is no clock divider required for this clock.
- Interface Clock Group (ICG). This group has clocks that are provided externally, like clocks from physical-side interface (PHY) and PL.

PL side peripherals can be operated through a PL clock (FCLK_CLK0...3). They generate the frequency ranges from 0.1 to 250 MHz.

Resets

There are many applicable resets:

- External power on reset (POR) - Triggered by external pin assertion
- Internal POR - Triggered by software register write or safety errors.
- "System" reset - Triggered by external pin assertion, or register write or safety errors. This reset does not reset debug logic.
- PS "System" reset - Triggered by a hardware error or by a register write. This is a PS only reset and PL remains active.
- PS POR reset - Similar to External POR but only for PS
- Full power subsystem (FPS) reset - Triggered by error or register write and used to reset Full Power Domain
- RPU Reset - Triggered by errors or register write, explicitly to reset RPU

See [Fabric Reset Enable in Chapter 4](#). Also for more details about the individual resets, see the *Zynq UltraScale All Programmable MPSoC Technical Reference Manual* (UG1085) [\[Ref 1\]](#).

Design Flow Steps

This chapter describes customizing and generating the core, constraining the core, and the simulation, synthesis and implementation steps that are specific to this IP core. More detailed information about the standard Vivado® design flows and the IP integrator can be found in the following Vivado Design Suite user guides:

- *Vivado Design Suite User Guide: Designing IP Subsystems using IP Integrator* (UG994) [\[Ref 3\]](#)
- *Vivado Design Suite User Guide: Designing with IP* (UG896) [\[Ref 4\]](#)
- *Vivado Design Suite User Guide: Getting Started* (UG910) [\[Ref 5\]](#)
- *Vivado Design Suite User Guide: Logic Simulation* (UG900) [\[Ref 6\]](#)

Customizing and Generating the Core

This section includes information about using the Vivado Design Suite to customize and generate the core.

If you are customizing and generating the core in the Vivado IP integrator, see the *Vivado Design Suite User Guide: Designing IP Subsystems using IP Integrator* (UG994) [\[Ref 3\]](#) for detailed information. The IP integrator might auto-compute certain configuration values when validating or generating the design, as noted in this section. To check whether the values do change, see the description of the parameters in this chapter. To view the parameter value, run the `validate_bd_design` command in the Tcl Console.

You can customize the IP for use in your design by specifying values for the various parameters associated with the IP core in the IP integrator using the following steps:

1. Select the IP from the Vivado IP catalog.
2. Double-click the selected IP, or select the **Customize IP** command from the toolbar or right-click menu.

For details, see the *Vivado Design Suite User Guide: Designing with IP* (UG896) [\[Ref 4\]](#), and the *Vivado Design Suite User Guide: Getting Started* (UG910). [\[Ref 5\]](#).

The **Zynq UltraScale+ Block Design** page with a block diagram appears in the window (Figure 4-4). Review the contents of the block diagram. The green colored blocks in the diagram are configurable.



TIP: To open the corresponding configuration page, you can click a green block, or select the page in the Page Navigator at the left side.

Note: Figures in this chapter are illustrations of the Vivado Integrated Design Environment (IDE). This layout might vary from the current version.

Preset Support

This section discusses two presets: IP preset and board preset.

IP Preset

An option is provided in the PCW GUI to save the IP configuration as preset and apply. These IP presets are for you to use when you see them as applicable, such as managing IP settings across different projects and/or states during their development stages. This saves the entire IP configuration. Figure 4-1 shows the option.



Figure 4-1: Preset

Board Preset

For the Zynq MPSoC board, presets are tightly coupled with boards. To obtain the board preset support, you must select the Xilinx board part (for example, ZCU102, ZCU106) when creating the project. The board preset is different from IP presets.

After the Zynq MPSoC IP is instantiated in the board design, the **Run Block Automation** ribbon appears on the block diagram as shown in Figure 4-2

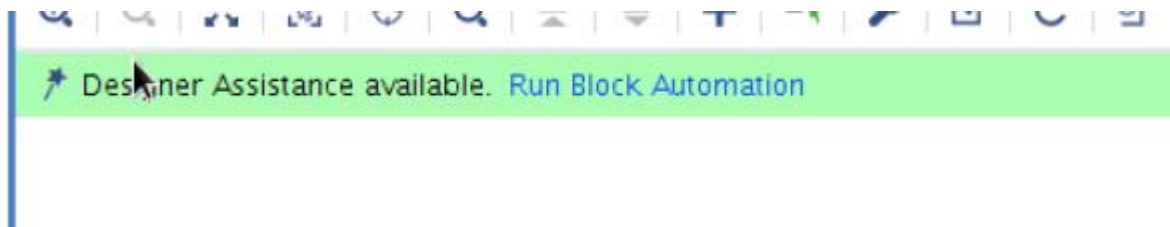

Figure 4-2: Run Block Automation

After clicking **Run Block Automation**, Apply Board Preset appears as shown in Figure 4-3.

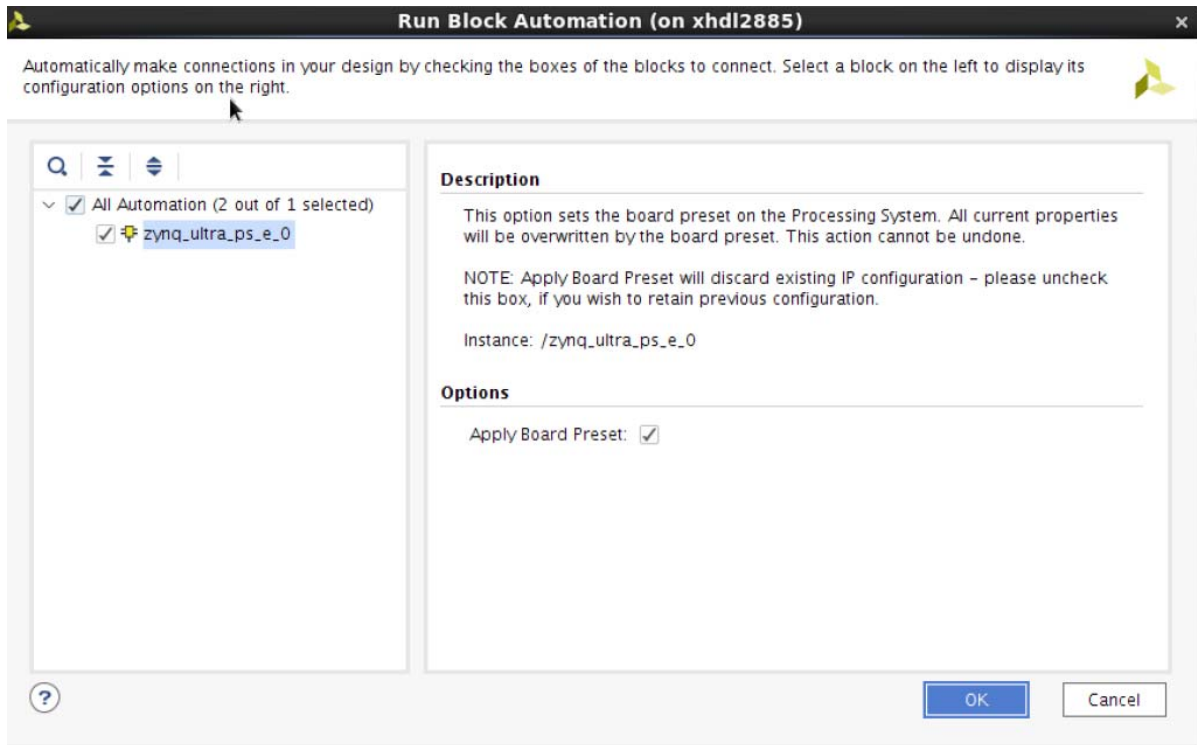

Figure 4-3: Apply Board Reset

You can re-customize your needs after preset is applied, but for the devices earlier than production (es-1, es-2) the **Run Block Automation** ribbon appears again on the block diagram upon re customization, but you can safely ignore this.

PS Zynq UltraScale+ MPSoC Block Design

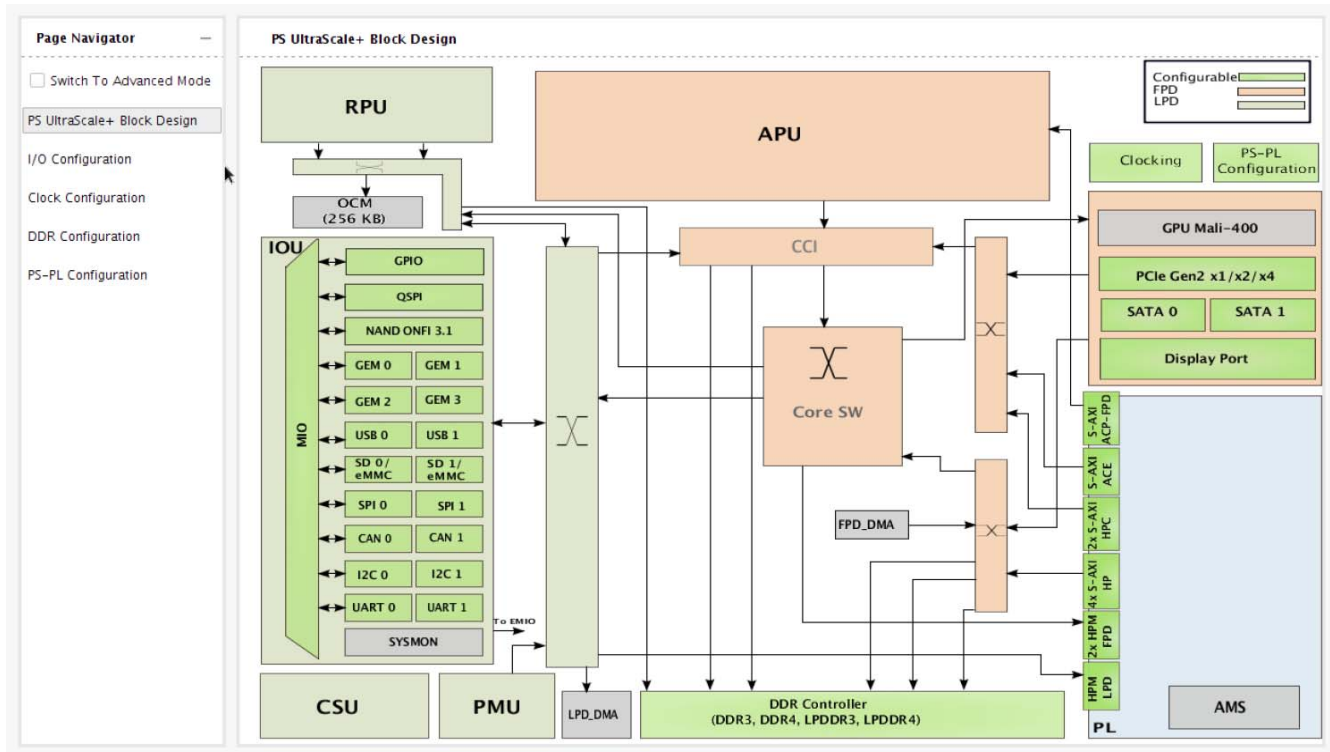

Figure 4-4: PS Zynq UltraScale+ Block Design Page

The colors in the PS UltraScale+™ Block Design page have the following meanings:

- Light Green color shows Low Power Domain
- Light Orange color shows Full Power Domain
- Dark Green color shows the components that you can configure.

I/O Configuration

This page shows pin assignments for individual signals of an interface of PS components. You can assign attributes for the signals.

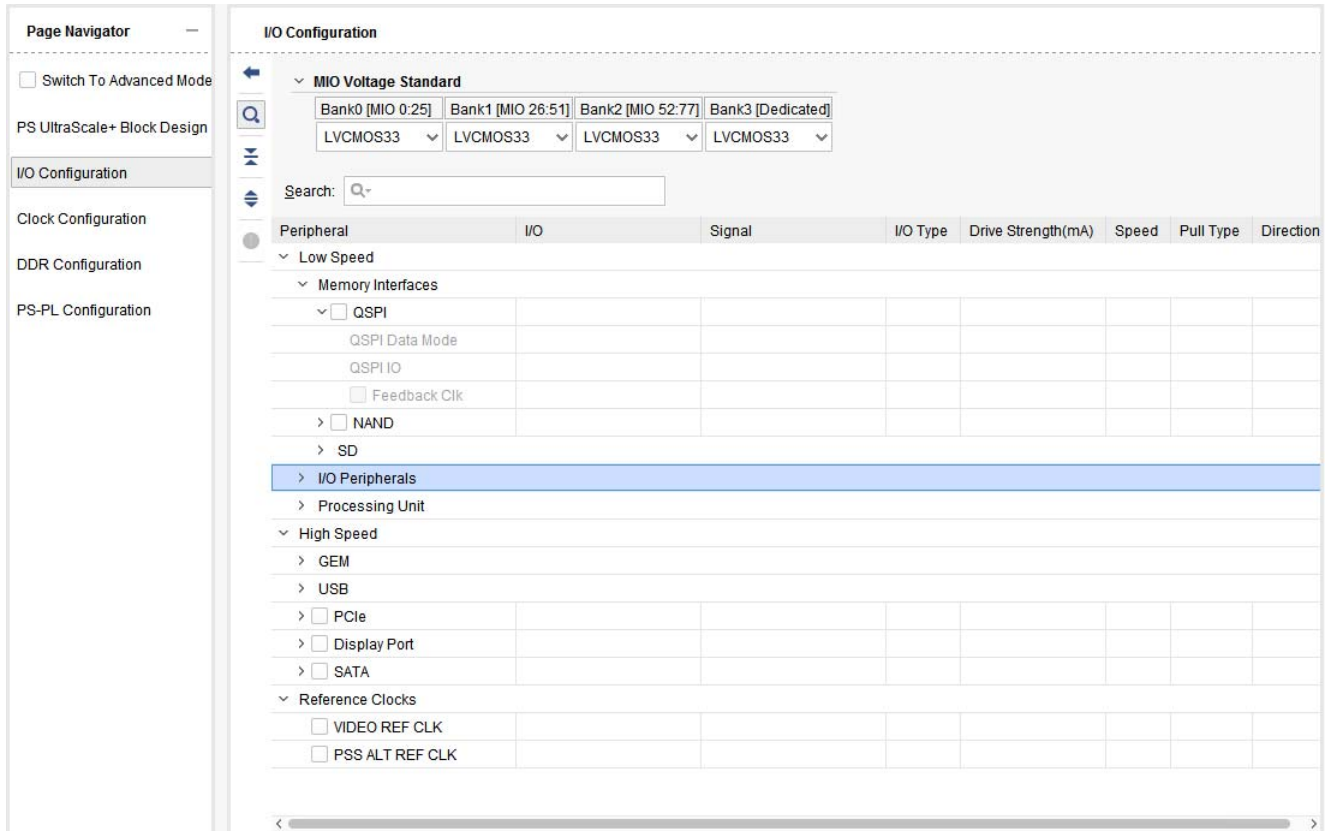

Figure 4-5: I/O Configuration Page

MIO Voltage Standard

Each of these I/O pins can be routed through MIOs, EMIOs, or GT Lanes as applicable. Each peripheral pin can be routed through a subset of 78 MIOs as required. Alternatively the same pins from each peripheral can be routed to EMIO signals which brings the signal to PL section of the device for further processing.

For more information on the MIO and EMIO, refer to the Multiplexed I/O, chapter 26 in the *Zynq UltraScale All Programmable MPSoC Technical Reference Manual* (UG1085) [Ref 1].

MIOs available for peripheral pinouts are divided into three Banks: Bank0 (MIO 0-25), Bank1 (MIO 26-51), and Bank2 (MIO 52-77). Each bank has a common I/O Voltage Standard for all its MIOs and the default value for this is LVC MOS33.

Peripheral

Low Speed

- Memory Interface. These are the static memory controllers present in the PS.
- I/O Peripherals. These are the I/O peripherals present in the PS.
- Application Processing Unit. These are APU specific resources such as watch dog timer, Trace and Triple Timer Counter.

High Speed

Pins from high-speed peripherals, like, PCIe, SATA, Gigabit Ethernet Module (GEM) (in SGMII mode), Display Port and USB 3.0 can be routed to SERDES by selecting the appropriate GT lanes in the I/O column.

I/O Configuration Columns

- **I/O** – Used to configure I/O pins of the respective peripherals.
- **Signal** – Displays information about the signal name driven by the respective I/O pins.
- **I/O Type** – CMOS/Schmitt. Select CMOS or Schmitt as the input I/O voltage type. The Schmitt Voltage type has a higher tolerance to noise than CMOS voltage type.
- **Drive Strength (mA)** – Used to select the drive strength. Possible values are 2, 4, 8, and 12.
- **Speed** – Fast/Slow. Specifies whether the device is fast or slow depending on the slew rate. If the slew rate is 0, the device is fast; else the device is slow.
- **Pull Type** – Used to enable/disable a device along with pull up or pull down. Possible values are **pullup**, **pulldown**, and **disable**.
- **Direction** – The direction can be fixed for certain signals.

Clock Configuration

This page enables you to configure the peripheral clocks, PL clocks, DDR, and CPU clocks. The PCW provides two options, Input Clocks and Output Clocks, to configure the various associated clocks.

Input Clocks

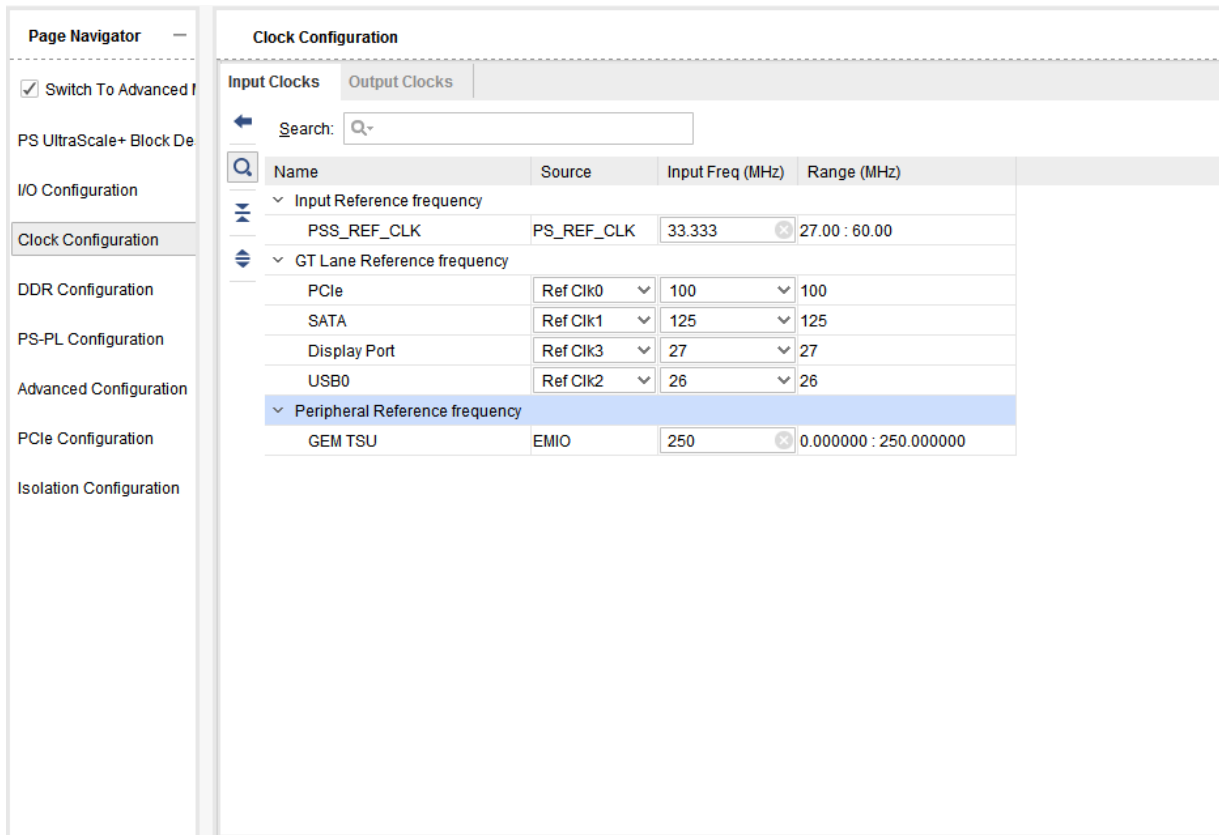

Figure 4-6: Clock Configuration Page (Input Clocks)

- **Input Reference frequency** – This is the frequency of the clock that is coming from the on-board clock source. There can be three reference clocks: PSS_REF_CLK, PS ALT REF CLK, and PSU VIDEO REF CLK. PSS ALT REF CLK and PSU VIDEO REF CLK are enabled based on the user section in the I/O Configuration tab.
- **GT Lane Reference frequency** – This is the frequency of the clock that is coming from the on-board clock source. There can be individual reference clock sources for PCIe, SATA, Display Port and USB.
- **Peripheral Reference frequency** – This section lists the clock pins and the input frequencies for the peripherals where the clock is driven by MIO pins. Note that

MIOCLK for the corresponding peripherals needs to be enabled in the I/O Configuration page for the pin to be listed here.

Output Clocks

In the default mode (i.e., when **Enable Manual Mode** is turned off), the wizard (PCW) automatically calculates the M (Multiplier) and D (Divisor) values to ensure that the tool meets the requested frequency to the nearest possible value. The wizard might or might not achieve all the requested values since each PLL caters to multiple peripherals. An internal algorithm will create the best possible solution based on the following conditions:

- When Ethernet is enabled, wizard tries to give the precedence to the solution which has the Ethernet frequency of 125 MHz.
- When Ethernet is enabled and if there are multiple clocking solutions with the identical Ethernet frequency of 125 MHz, then the tool will take the precedence of the solution that will have the least possible total error (sum of requested frequencies - sum of actual frequencies) value of various peripherals.
- The tool will also take the precedence of the solution with least possible total error value of various peripherals even when the Ethernet is disabled.

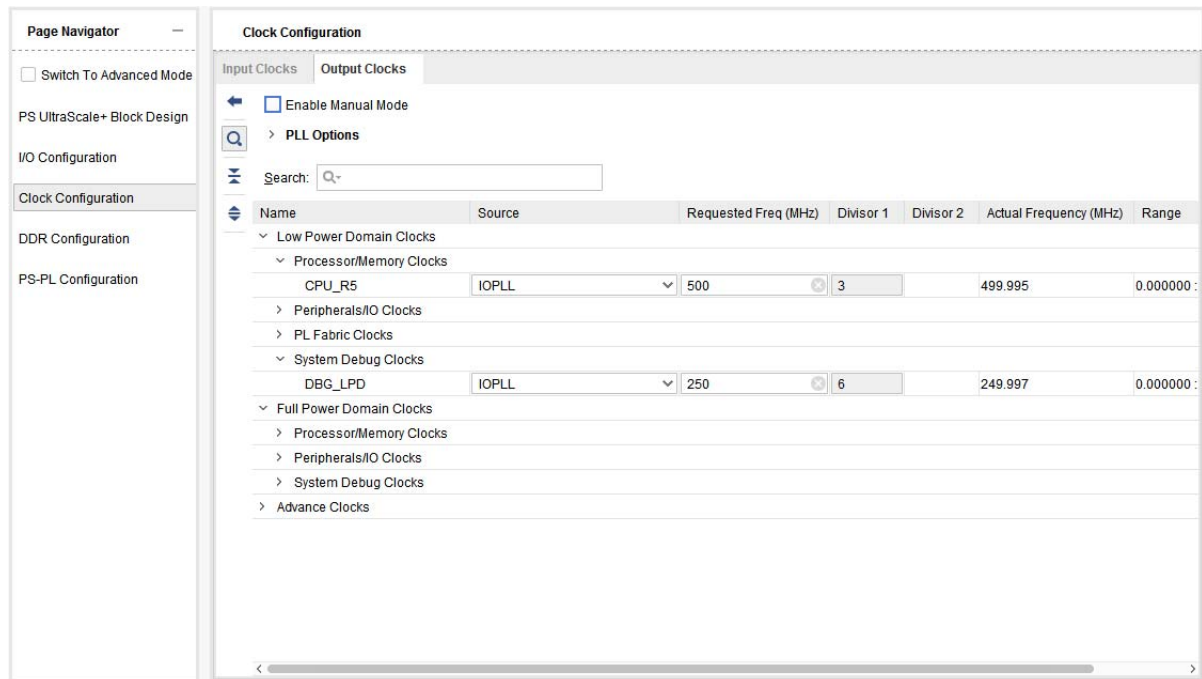

Figure 4-7: Clock Configuration Page (Output Clocks)

Enable Manual Mode – When you select this mode, different options are displayed. You can directly input the M and D values for various PLLs as well as individual divisor values enabling finer control. For more details, see [Output Clocks \(Enable Manual Mode\)](#)

Low Power Domain Clocks

- **Processor/Memory Clocks** – Clock configuration for the CPU_R5 Processor
- **Peripherals/IO Clocks** – Clock configuration for low-speed peripheral devices.
- **PL Clocks** – PS generated clock to PL: PL0, PL1, PL2, and PL3
- **System Debug Clocks** – Clock configuration for debug modules DBG_LPD

Full Power Domain Clocks

- **Processor/Memory Clocks** – Clock configuration for A53 CPU (ACPU), GPU, and DDR
- **Peripherals/IO Clocks** – Clock configuration for low-speed peripheral devices.
- **System Debug Clocks** – Clock configuration for debug modules: DBG_FPD, DBG_TRACE, and DBG_TSTMP

Advance Clocks

- **Low Power Domain Interconnect and Switch clocks** – Clocks used by the interconnect and switches internal to the PS.
- **Full Power Domain Interconnect and Switch clocks** – Clocks used by the interconnect and switches internal to the PS.

Column Descriptions for Output Clocks

- **Source** – This is the source PLL for the corresponding peripheral.
- **Requested Freq (MHz)** – This is the input frequency given to the corresponding peripheral
- **Divisor 1** – Denotes the 1st stage 6-bit programmable Divisor
- **Divisor 2** – Denotes the 2nd stage 6-bit programmable Divisor
- **Actual Freq (MHz)** – This is the actual frequency calculated by the Processor Configuration Wizard. The clocking algorithm works with multiple factors, peripherals, PLLs and priorities; therefore, in certain cases, the actual frequency might be different than the Input Frequency.
- **Range (MHz)** – This is the Minimum/Maximum range of the frequency that the corresponding peripheral can work with. In this mode, you must configure the M and D values to achieve the desired frequency. When this mode is enabled, the values requested through Output mode will be overwritten

Note: In order to modify the clock frequencies/divisors, the corresponding clock must be enabled

PLL Options for Output Clocks

There are five PLLs available in the MPSoC that are spread across the two domains, LPD and FPD. There are three PLLs namely APLL, DPLL and VPLL in the FPD domain while the RPLL and the IOPLL are in the LPD domain. PCW provides an option to make use of the cross domain PLLs to be used to source the cross-over peripheral. This gives additional options to select from a pool of all PLLs.

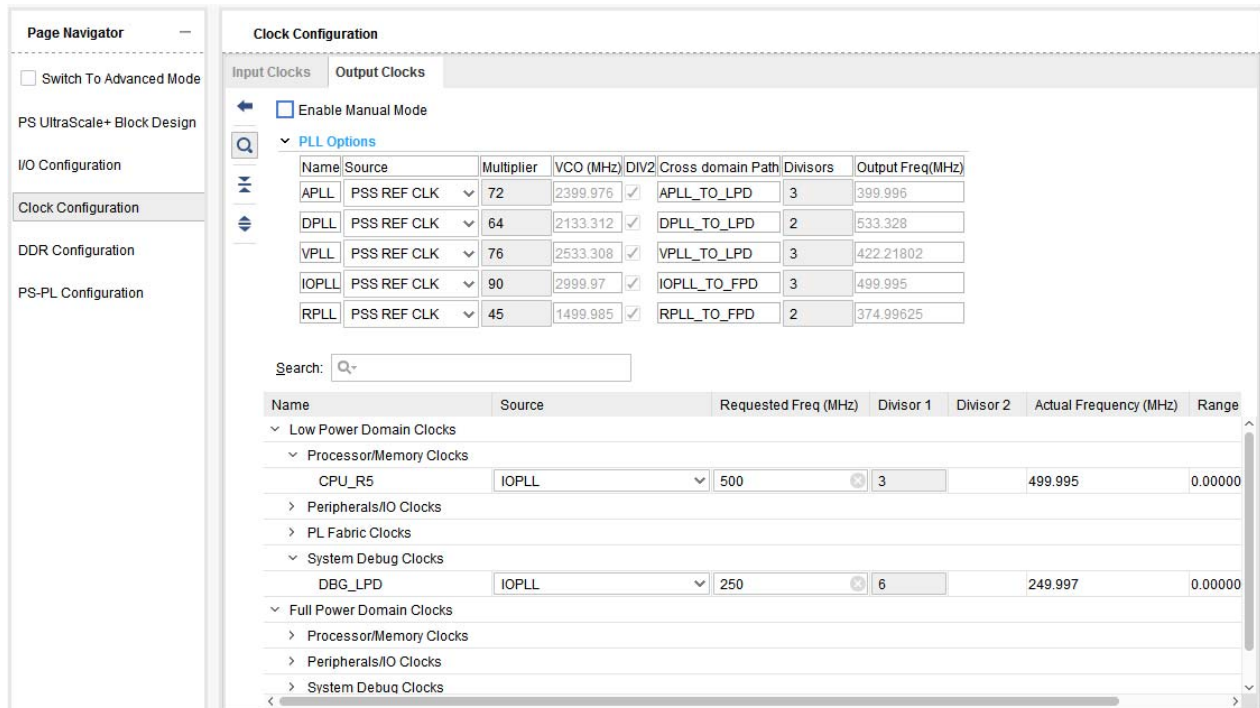

The screenshot shows the 'Clock Configuration' tool with the 'Output Clocks' tab selected. Under 'PLL Options', a table lists the following configurations:

Name	Source	Multiplier	VCO (MHz)	DIV2	Cross domain Path	Divisors	Output Freq(MHz)
APLL	PSS REF CLK	72	2399.976	✓	APLL_TO_LPD	3	399.996
DPLL	PSS REF CLK	64	2133.312	✓	DPLL_TO_LPD	2	533.328
VPLL	PSS REF CLK	76	2533.308	✓	VPLL_TO_LPD	3	422.21802
IOPLL	PSS REF CLK	90	2999.97	✓	IOPLL_TO_FPD	3	499.995
RPLL	PSS REF CLK	45	1499.985	✓	RPLL_TO_FPD	2	374.99625

Below this table, a search bar and a detailed table for selected PLLs are shown:

Name	Source	Requested Freq (MHz)	Divisor 1	Divisor 2	Actual Frequency (MHz)	Range
Low Power Domain Clocks						
Processor/Memory Clocks						
CPU_R5	IOPLL	500	3		499.995	0.00000
Peripherals/IO Clocks						
PL Fabric Clocks						
System Debug Clocks						
DBG_LPD	IOPLL	250	6		249.997	0.00000
Full Power Domain Clocks						
Processor/Memory Clocks						
Peripherals/IO Clocks						
System Debug Clocks						

Figure 4-8: PLL Options for Output Clocks

PLL Options

- **Name** – One of the five PLLs available in PS: APLL, VPLL, DPLL, IOPLL, and RPLL.
- **Source** – This is the source PLL for the corresponding peripheral.
- **Requested Freq (MHz)** – This is the input frequency given to the corresponding peripheral
- **Divisor 1** – Denotes the 1st stage 6-bit programmable Divisor.
- **Divisor 2** – Denotes the 2nd stage 6-bit programmable Divisor.
- **Actual Freq (MHz)** – This is the actual frequency calculated by the Processor Configuration Wizard. The clocking algorithm works with multiple factors, peripherals, PLLs and priorities; therefore, in certain cases, the actual frequency might be different than the Input Frequency.

- **Range (MHz)** – This is the Minimum/Maximum range of the frequency that the corresponding peripheral can work with.

Note: In the default mode, we cannot always get the actual frequency. It depends on the load on PLL (Number of different clocks in PLL drives).

Output Clocks (Enable Manual Mode)

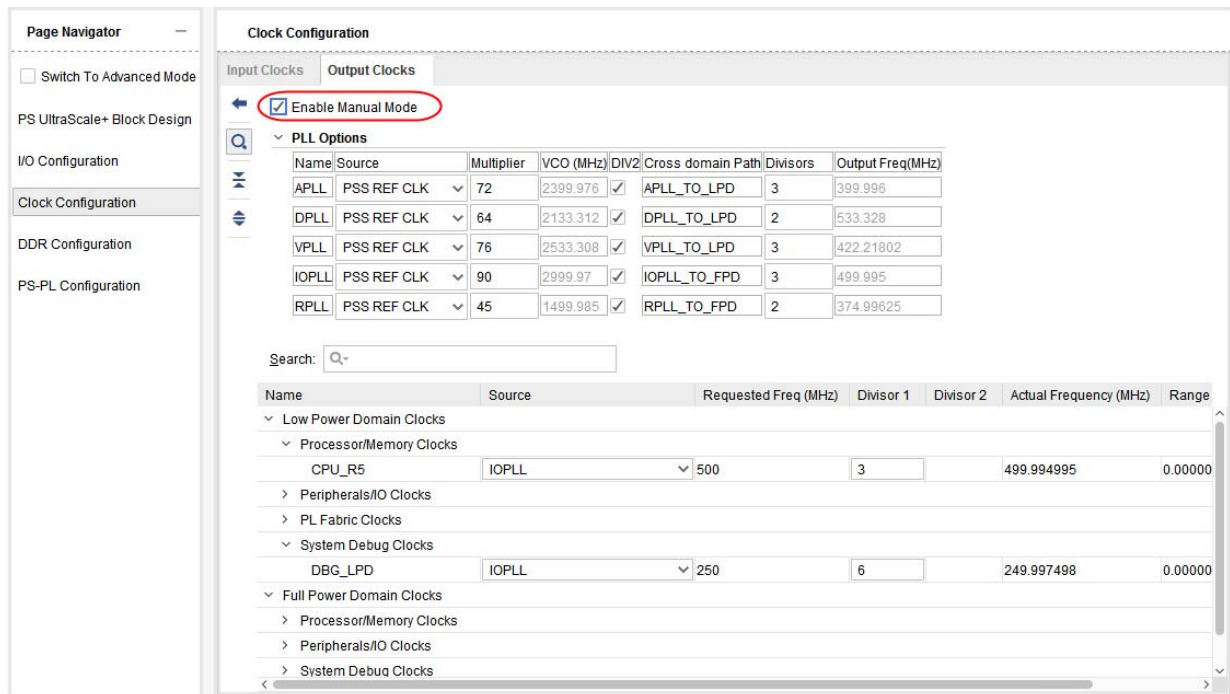

The screenshot shows the 'Clock Configuration' tool interface. The 'Output Clocks' tab is active, and the 'Enable Manual Mode' checkbox is checked. Below this, there is a table of PLL Options:

Name	Source	Multiplier	VCO (MHz)	DIV2	Cross domain Path	Divisors	Output Freq(MHz)
APLL	PSS REF CLK	72	2399.976	✓	APLL_TO_LPD	3	399.996
DPPLL	PSS REF CLK	64	2133.312	✓	DPPLL_TO_LPD	2	533.328
VPPLL	PSS REF CLK	76	2533.308	✓	VPPLL_TO_LPD	3	422.21802
IOPLL	PSS REF CLK	90	2999.97	✓	IOPLL_TO_FPD	3	499.995
RPLL	PSS REF CLK	45	1499.985	✓	RPLL_TO_FPD	2	374.99625

Below the PLL options, there is a search bar and a detailed table of output clocks:

Name	Source	Requested Freq (MHz)	Divisor 1	Divisor 2	Actual Frequency (MHz)	Range
Low Power Domain Clocks						
Processor/Memory Clocks						
CPU_R5	IOPLL	500	3		499.994995	0.00000
Peripherals/IO Clocks						
PL Fabric Clocks						
System Debug Clocks						
DBG_LPD	IOPLL	250	6		249.997498	0.00000
Full Power Domain Clocks						
Processor/Memory Clocks						
Peripherals/IO Clocks						
System Debug Clocks						

Figure 4-9: Manual Mode

Low Power Domain Clocks

- **Processor/Memory Clocks** – Clock configuration for the CPU_R5 Processor
- **Peripherals/IO Clocks** – Clock configuration for low-speed peripheral devices.
- **PL Clocks** – PS generated clock to PL: PL0, PL1, PL2, and PL3
- **System Debug Clocks** – Clock configuration for debug modules DBG_LPD

Full Power Domain Clocks

- **Processor/Memory Clocks** – Clock configuration for A53 CPU (ACPU), GPU, and DDR
- **Peripherals/IO Clocks** – Clock configuration for low-speed peripheral devices.
- **System Debug Clocks** – Clock configuration for debug modules: DBG_FPD, DBG_TRACE, and DBG_TSTMP

Clock Configuration Columns for Output Clocks

- **Source** – This is the source PLL for the corresponding peripheral.
- **Requested Freq (MHz)** – This is the input frequency given to the corresponding peripheral. The values in this column are not applicable in the manual mode and should be ignored. These are used only in automatic mode.
- **Divisor 1** – Denotes the 1st stage 6-bit programmable Divisor.
- **Divisor 2** – Denotes the 2nd stage 6-bit programmable Divisor.
- **Actual Freq (MHz)** – In Manual Mode, the actual frequency is a result of your selection of PLL Multiplier (M) and Divide (D) choices.
- **Range (MHz)** – This is the Minimum/Maximum range of the frequency that the corresponding peripheral can work with.

Fractional Clocking

The fractional clocking enable (FracEn) option is provided in Vivado IDE only for the DP_VIDEO and DP_AUDIO peripherals to facilitate the precise clocking as these require very precise clocking. When this option is checked/enabled the fractional value for the feedback value is configured for the respective PLL. See [Figure 4-10](#).

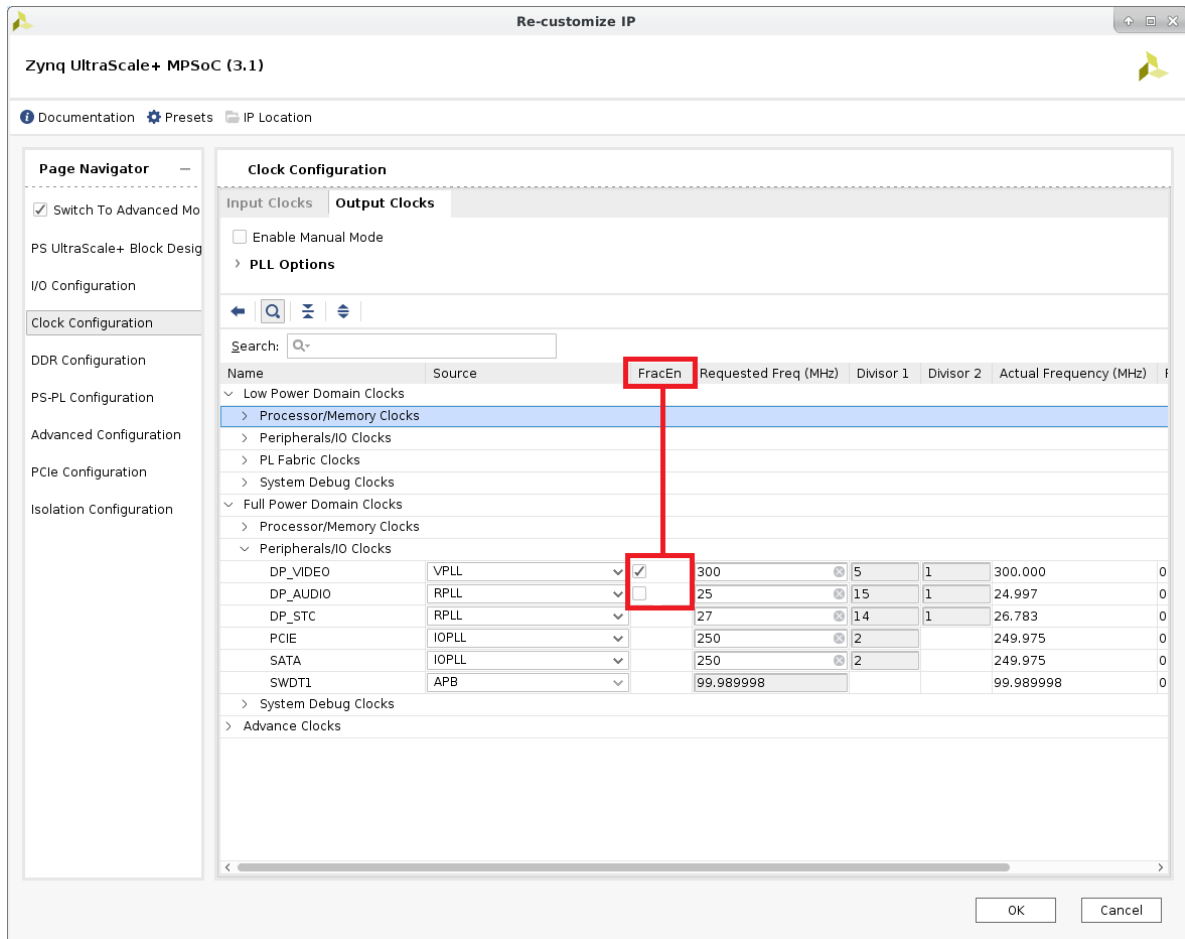

Figure 4-10: FracEnable

DDR Configuration

The page allows you to set the DDR controller configurations.

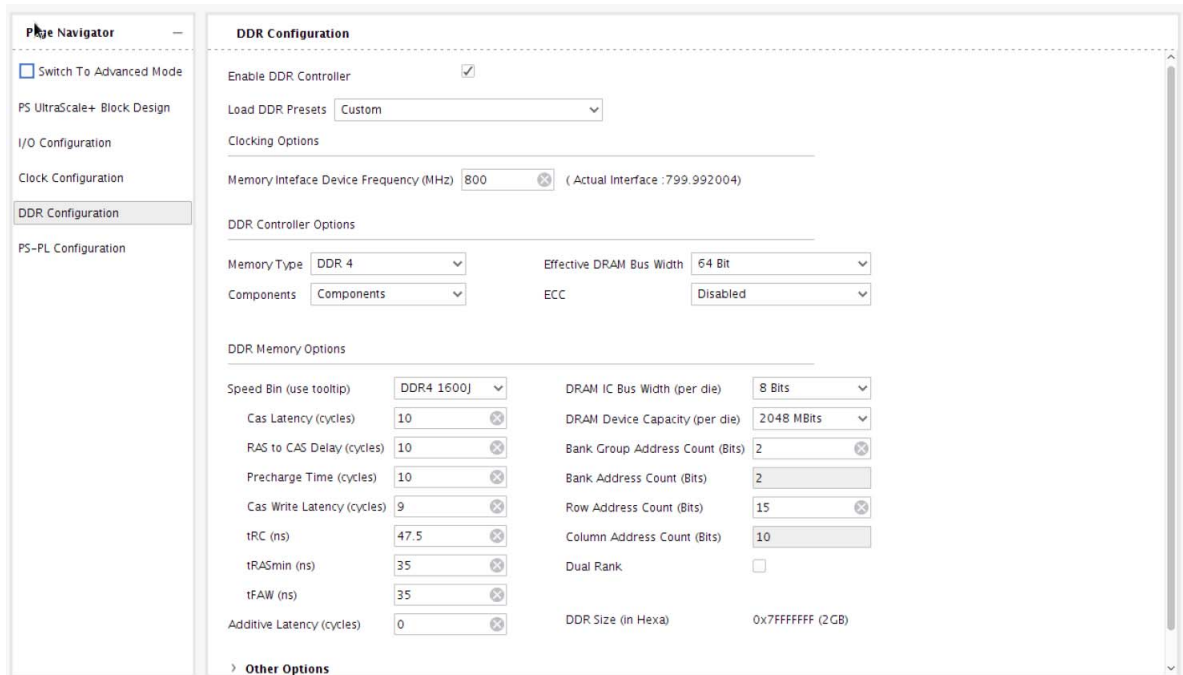

Figure 4-11: DDR Controller Options

- **Enable DDR Controller**– Enable DDR controller for Zynq® UltraScale+ MPSoC PS.

Load DDR Presets

This option loads factory provided presets. Currently Xilinx provides three presets.

- **DDR4_KINGSTON_KVR21SE15S8**: This configuration is for KINGSTON DDR4 part KVR21SE15S8/4.
- **DDR4_MICRON_MT40A256M16GE_083E**: This configuration is for MICRON DDR4 part MT40A256M16GE 083E.
- **DDR4_SAMSUNG_K4A8G165WB_BCRC**: This configuration is for SAMSUNG DDR4 part K4A8G165WB BCRC.

When these presets are loaded, all the DDR4 configurations will be loaded automatically. Check the requested Memory Interface Device frequency and Actual frequency. Both should be the same or nearly the same. If not, you should check clocking page and adjust the DDR frequency under Processor/Memory clocks.

Clocking Options

- **Memory Interface Device Frequency (MHz)** – This is the requested frequency for the DDR memory part. This Interface is the actual frequency from the PLL which drives the DDR. All the DRCs for the timing parameter are computed based on the actual interface frequency.

DDR Controller Options

- **Memory Type** – Type of memory interface. For more details about different memory types, see the *Zynq UltraScale All Programmable MPSoC Technical Reference Manual* (UG1085) [Ref 1].
- **Components** – Types of the components supported by the memory controller.
- **Effective DRAM Bus Width** – Data width for DDR interface, not including ECC data width
- **ECC** – Enables Error correction code support.

DDR Memory Options

- **Speed Bin** – Device speed grade. The speed bin should be set to the actual frequency for best performance. Letters defined by the JEDEC specification.
- **CAS Latency (cycles)** – Column Access strobe latency in memory clock cycles. It refers to the amount of time it takes for data to appear on the pins of the memory module. When using DBI, do not increase the latency by 2 cycles.
- **CAS Write Latency (cycles)** – Write latency setting in memory clock cycles.
- **Additive Latency (cycles)** – Additive latency setting in memory clock cycles.
- **RAS To CAS (cycles)** – Row address to column address delay time. It is the time required between the memory controller asserting a row address strobe (RAS), and then asserting the column address strobe (CAS).
- **Precharge Time (cycles)** – Precharge time is the number of clock cycles needed to terminate access to an open row of memory and open access to the next row
- **tRC (ns)** – Row cycle time
- **tRASmin (ns)** – Minimum number of memory clock cycles required between an Active and Precharge command.
- **tFAW (ns)** – Determines the number of activates that can be performed within a certain window of time.
- **DRAM IC Bus Width (per die)**– Width of individual DRAM components
- **DRAM Device Capacity (per die)**– Storage capacity of individual DRAM components

- **Bank Group Address Count (Bits)** – Number of bank address pins
- **Bank Address Count (Bits)** – Number of Bank address pins.
- **Row Address Count (Bits)** – Number of Row address pins
- **Col Address Count (Bits)** – Number of Column address pins
- **DDR Size (in Hex)** – Total DDR Size
- **Dual Rank** - Enables the second rank/CS_N pin

Note: Hover on each of the above memory options in IP User Interface to find additional information.

Other Options

- **Memory Address Map (Bank-Row-Col mapping)** – Indicates the mapping between the AXI address bus and the physical memory.
- **Data mask and DBI** – Usage of data mask (DM) and data bus inversion (DBI).
- **DIMM Address mirror** – Compensates for swapped address bits on the odd rank for clamshell PCB topologies.
- Parity - Enables DDR4 parity checking
- Power Down Enable - Power down after a PWRTMG.powerdown_to_x32 cycles
- Clock Stop - Stop the clock to DRAM during self-refresh or during power down.
- Low-Power Auto Self-Refresh - Controls self-refresh temperature ranges or enable automatic mode
- Temp Controlled Refresh - Allows the refresh rate to be adjusted by temperature
- Temp Controlled Refresh Range - Temperature range for determining refresh rate
- Fine Granularity Refresh Mode - Generates more frequent refreshes with shorter tRFC times
- Self Refresh Abort - Enables the self refresh abort bit in the DRAM MR4 register
- 2nd Clock - Enables second output clock for LPDDR3 packages/topologies with two clocks
- Address Copy - Duplicates the address/command interfaces for LPDDR3 packages/topologies with two CA interfaces

PS-PL Configuration

This page allows you to configure PS-PL interfaces including AXI, HP, and ACP bus interfaces.

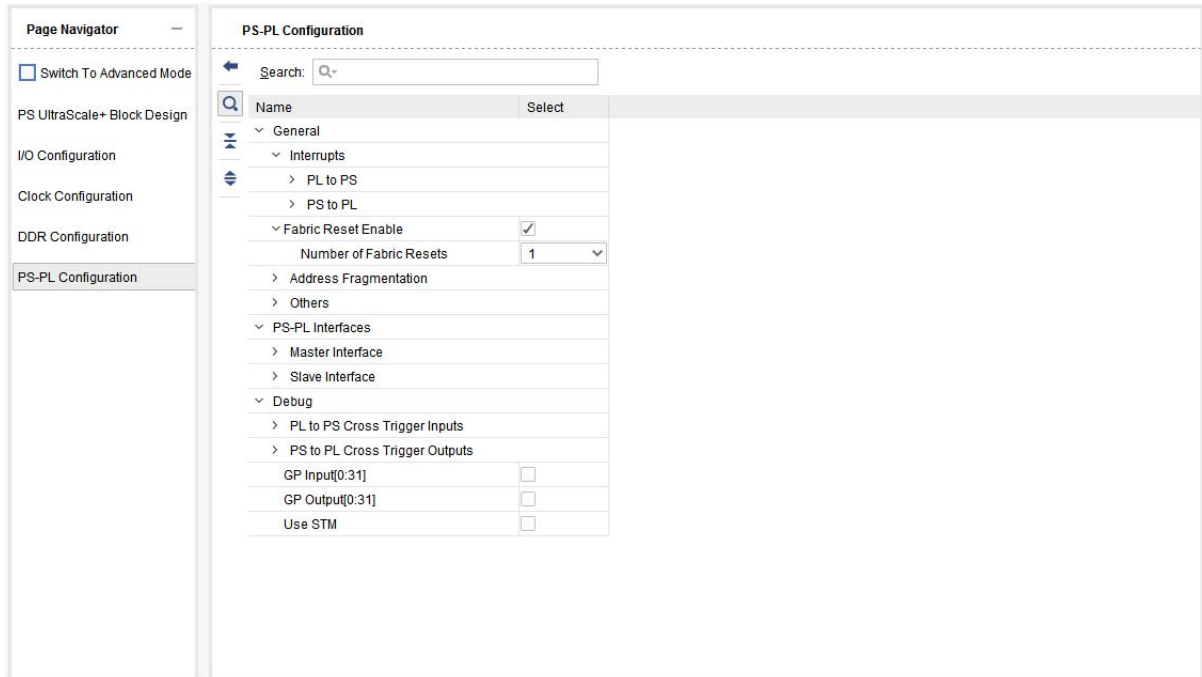

Figure 4-12: PS-PL Configuration Page

General

Interrupts

Fabric Reset Enable

Fabric Resets can be enabled from **PS - PL Configuration > General > Fabric Reset Enable**. Up to four PL Reset signals can be enabled with the default being one reset signal enabled.

There are a total of four PS-PL resets that are available. These four PL resets that are user selectable from within the PCW use the available last four out of the 96 EMIOs. Based on their selection from 0-4, the number of EMIO is reduced from 96 to 92 which should be taken into account. The selection for the fabric reset can be done from the **General** node available in the PS-PL configuration page.

The corresponding registers required to toggle the EMIOs for realizing the PL resets is taken care of by the PCW through output files that are generated as a part of output products.

Address Fragmentation

With the availability of several peripherals within PS, PCW provides an organized way to access these peripherals. The **Address Fragmentation** allows you to expand the peripherals based on the address space in which they are assigned within the Zynq® UltraScale+™ MPSoC. Lower LPD slaves, Upper LPD slaves, FPD slaves and others are few of the available choices. Based on the selection, only the selected segments will be shown up in the address editor in Vivado along with the addresses to which they will be mapped to the PL- master.

This way only the list of selected peripherals will appear in the address editor. This can be used where the requirement is to have more address space available for the PL components, rather than a single address block assigned to Zynq UltraScale+ MPSoC addressable components.

Notes:

1. High DDR segment is not enabled if the DDR size is less than or equal to 2GB.
2. When the DDR size is greater than 2GB, the High DDR segment can be used to have DDR addressed in a higher address space, this is limited to 4GB of DDR size.
3. You must have a 64-bit master in the PL in order to access higher address space above 4GB.

For more information, see the *Zynq UltraScale All Programmable MPSoC Technical Reference Manual* (UG1085) [\[Ref 1\]](#).

Others

- Use LPD_DMA(ADMA) – DMA in Low power domain
- Use FPD_DMA(GDMA) – DMA in Full power domain
- USE RTC – Real Time clock
- Use Event RPU and Use Proc Event Bus – The processor includes logic to detect various events that can occur, for example, a cache miss. These events provide useful information about the behavior of the processor for use when debugging or profiling code. The events are made visible on an output event bus and can be counted using registers in the performance monitoring unit.
- Live Audio and Live Video – The DisplayPort controller supports live audio and video channels from the PL. These audio and video streams interface to the DisplayPort controller and provide live audio and video overlays from the PL.

PS-PL Interfaces

Master Interface

- AXI HPM0 FPD – High performance master 0 in full power domain
- AXI HPM1 FPD – High performance master 1 in full power domain
- AXI HPM0 LPD – High performance master 0 in low power domain.

Each interface supports 32, 64, 1nd 128 data widths.

Slave Interface

- AXI HP and sub options – There are two (AXI HPC0 FPD, AXI HPC1 FPD) high performance AXI I/O coherent master interfaces in full-power domain; four (AXI HP0 FPD, AXI HP1 FPD, AXI HP2 FPD, AXI HP3 FPD) high performance slave AXI interfaces in full-power domain; one (AXI LPD) AXI interface in low-power domain.

Each interface supports 32, 64, 1nd 128 data widths.

- S AXI ACP – There is one Accelerator Coherency Port that can be connected to a DMA engine or a non-cached coherent master.
- S AXI ACE – There is one AXI Coherency Extension slave.

Debug

The debug feature enables configuration of cross trigger signals. This provides debug capability for accessing the PS debug structure allowing integrated test and debug on both PS and PL simultaneously.

Fabric Trigger Macrocell (FTM) For Programmable Logic Test And Debug

It is based on the ARM® CoreSight® architecture. The FTM receives trace data from the PL and formats it into trace packets to be combined with the trace packets from other trace source components such as PTM and Instrumentation Trace Macrocell (ITM). With this capability, PL events can easily be traced simultaneously with PS events.

The FTM also supports cross-triggering between the PS and PL, except for the trace dumping feature. In addition, the FTM provides general-purpose debug signals between the PS and PL.

This block provides:

- General purpose I/Os, 32 bits to the PL and 32 bits from the PL. These are accessed through reads and writes to registers.
- Trigger signals, four pairs to the PL and four pairs from the PL. Each pair consists of a trigger signal and an acknowledge signal, and follows the ARM standard CTI handshake protocol

Options

- PL to PS Cross Trigger Inputs – Trigger signals, four pairs from the PL. Each pair consists of a trigger signal and an acknowledge signal, and follows the ARM® standard CTI handshake protocol.
- PL to PS Cross Trigger Outputs and sub options – Trigger signals, four pairs to the PL. Each pair consists of a trigger signal and an acknowledge signal, and follows the ARM standard CTI handshake protocol.
- GP Input[0:31] GP Output[0:31] – General purpose I/Os, 32 bits to the PL and 32 bits from the PL. These are accessed through reads and writes to registers.

Advanced Configuration

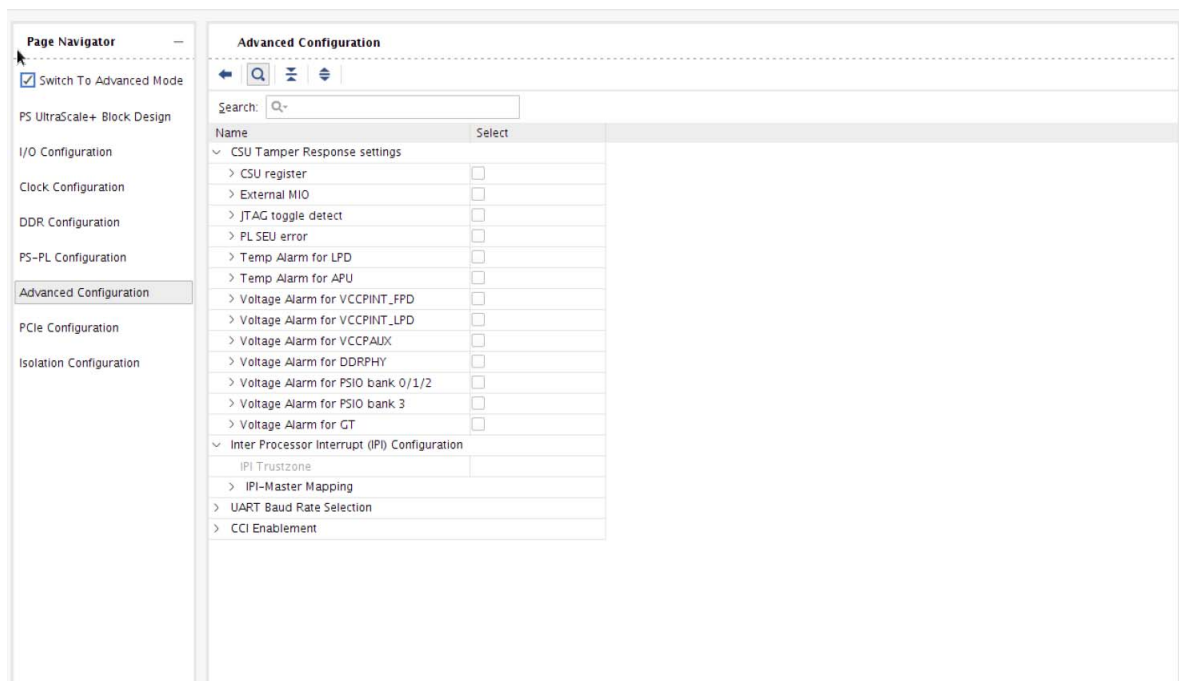

Figure 4-13: Advanced Configuration

CSU and Tamper Response Settings

CSU is responsible for loading the processing system (PS) first-stage boot loader (FSBL) code into the on-chip RAM (OCM) in both secure and non-secure boot modes. You can select, through the boot header, to execute the FSBL on the Cortex®-R5 or the Cortex-A53 processor. After FSBL execution starts, the CSU enters the post-configuration stage, which is responsible for system tamper response.

The CSU can be configured to have secure lock down, system reset, and system interrupt for some of the errors like PL single event upset (SEU) error, Temperature alarm, voltage alarm, etc. These options are available under **CSU Tamper Response settings** on the Advanced Configuration page.

Interrupts

One external tamper interrupt is mapped to CSU through MIO. There are three interrupts from CSU (PS) to PL as CSU WDT Interrupt, CSU DMA Interrupt, and CSU interrupt.

The CSU Interrupt is used to indicate that something in the CSU logic has caused an interrupt. The CSU interrupt status register holds the interrupt bits for all of the CSU logic except for the DMA. The following values can cause an interrupt in the CSU:

For more information, see the *Zynq UltraScale All Programmable MPSoC Technical Reference Manual* (UG1085) [Ref 1].

- AES done – Bit to notify Advanced Encryption done.
- PL INIT complete – Bit to indicate PL initialization is complete.
- AES error – Bit to indicate Advanced Encryption error.
- RSA done – Bit to Indicate RSA Encryption done.
- PL POR_B – Bit to indicate PL power on reset status.
- TMR fatal error – Bit to indicate Triple-Mode Redundant (TMR) fatal error
- SHA done – Bit to indicate Secure Hash Algorithm Encryption done.
- PL SEU error flag – Bit to indicate Single Even Upset error.
- APB SLVERR – An error bit to indicate the failure of a transfer.
- PL CFG done – Status bit to indicate PL configuration complete.
- PCAP FIFO overflow – Status bit to indicate Processor Configuration Access Port FIFO overflow.
- CSU RAM ECC error – Bit to indicate CSU RAM ECC error.

The CSU_DMA_IRQ will alert the system that the DMA has generated an interrupt. The CSU WDT Interrupt is from the CSU watch dog timer interrupt.

Options

For more information, see the *Zynq UltraScale All Programmable MPSoC Technical Reference Manual* (UG1085) [Ref 1].

- CSU Register – Setting bits in this register causes the CSU ROM to issue a system interrupt when the tamper event occurs.
- External MIO – Observation of MIOs that causes the CSU ROM to issue a system interrupt when the tamper event occurs.
- JTAG toggle detect – Bit to identify the change in the JTAG mode.
- PLU SEU error – Bit to indicate Single Even Upset error.
- Temp Alarm for LPD – Temperature alarm for Low Power/RPU domain.
- Temp Alarm for APU – Temperature alarm for APU/ Full power domain.
- Voltage Alarm for VCCPINT_FPD – Power rail removal alarm when VCCPINT_FPD is removed.
- Voltage Alarm for VCCPINT_LPD – Power rail removal alarm when VCCPINT_LPD is removed.
- Voltage Alarm for VCCPAUX – Power rail removal alarm when VCCPAUX is removed.
- Voltage Alarm for DDRPHY – Reference voltage observation signal for DDR PHY.
- Voltage Alarm for PSIO bank 0/1/2 – Reference voltage observation signal for PSIO bank 0/1/2.
- Voltage Alarm for PSIO bank 3 – Reference voltage observation signal for PSIO bank 3.
- Voltage Alarm for GT – Reference voltage observation signal for Gigabit transceivers.

IPI Master Slave Configuration

The Inter Processor Interrupt Block provides the ability for any processing unit to interrupt another processing unit by performing a register write.

There are 11 IPI channels (GEN_IPI_0 through GEN_IPI_10), out of which four channels (Channel 3, 4, 5, 6) are dedicated to PMU. The rest of the channels can be assigned to APU, RPU, and PL. With this Master assignment to each IPI channel protects corresponding channel using XPPU from unmapped masters.

Each IPI channel provides the registers to trigger the interrupts to any destination. The XPPU only allows the master that is associated with channel to access those registers. In addition to the registers, IPI channels are provided with the payload buffers.

XPPU only allows the master that is associated with buffers to access those buffers.

UART Baud Rate Selection

- UART0 Baud Rate – Specifies the UART baud rate for the UART0.
- UART1 Baud Rate – Specifies the UART baud rate for the UART1.

PCIe Configuration

Name	Select
Basic Settings	
Device Port Type	Root Port
Number of Lanes	x1
Link Speed	5.0 Gb/s
Max Payload Size	256 bytes
CRS Software Visibility	<input checked="" type="checkbox"/>
Device IDs	
Initial ID Values	
Vendor ID	0x10EE
Device ID	0xD021
Revision ID	0x0
Subsystem Vendor ID	0x10EE
Subsystem ID	0x7
Class Code	
Base Class	0x06
Sub Class	0x4
Interface	0x0
Value (Hex)	0x60400
BAR Settings	
BAR0	
Value (Hex)	0x0
BAR1	
Value (Hex)	0x0
Expansion ROM Enable	<input type="checkbox"/>
Enable AER Capability	<input type="checkbox"/>

Figure 4-14: PCIe Configuration

See the *UltraScale Devices Gen3 Integrated Block for PCI Express LogiCORE IP Product Guide* (PG156) [Ref 9] for a description of the properties.

Isolation Configurations

Note: The Isolation feature in PCW is supported for parts with ES2 and above. PCW does not support isolation for parts with ES1.

Zynq UltraScale+ MPSoC can simultaneously run multiple processors. You can physically and logically isolate these subsystems from one another and at times allow them to carefully exchange/communicate information in a controlled manner. Zynq UltraScale+ MPSoC IP enables you to capture these subsystems in several ways to suite your needs. You can partition your application using AXI transaction based inhibitors as well as physically isolated ones by not sharing any logic (e.g. utilizing the fabric to create truly isolated systems at signal level i.e. no signal connections between two or more subsystems). The Isolation Configuration tab of PCW focuses on enabling you to define these subsystems utilizing AXI transaction Inhibitors in addition to the ARM Trustzone infrastructure. For Zynq UltraScale+ MPSoC, these AXI transaction inhibitors take the form of XMPU (Xilinx® Memory Protection Unit) and XPPU (Xilinx® Peripheral Protection Unit) to block transactions between AXI Masters and Slaves. These two physical blocks are interspersed throughout the Zynq UltraScale+ MPSoC to allow you finer control of your access policy needs between subsystems. See *Zynq UltraScale All Programmable MPSoC Technical Reference Manual (UG1085)*[\[Ref 1\]](#) for more information on XMPU and XPPU.

The isolation settings are disabled by default. If you manually configure any isolation settings, they can affect your design flow as many embedded runtime components in the interface might rely on these settings. See the relevant [quick take videos](#) on how to use these settings to define your subsystems.

The PS Configuration Wizard (PCW) in the Vivado design tools allows you to configure **Isolation Configuration** under the Isolation configuration pane, which is part of the advanced configurations as shown in [Figure 4-15](#).

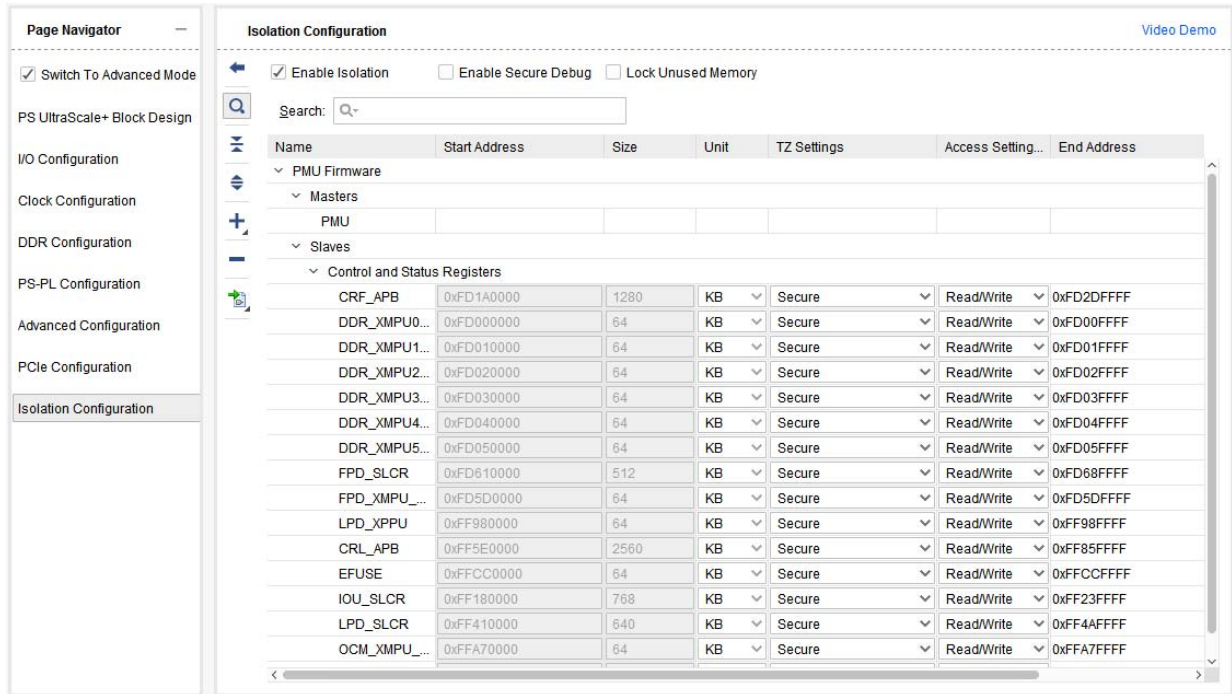

Figure 4-15: Isolation Configuration

The security and protection of each peripheral or any memory is achieved by creating subsystems (a subsystem is a group of slaves: peripherals, memory regions, and masters). and adding required slaves (Peripherals, memory regions) and masters that can access the specified slaves.

PCW has a subsystem concept, where a design can be categorized as different groups (subsystems). These subsystems are conceptual in nature, and allows you to configure security settings in an easy manner.

PCW allows you to protect and isolate the memories/peripherals, which are configured in the Isolation area of the Vivado design tools. The rest of the memories and peripherals are open to all masters.

PCW provides the following

- Memory partitioning and protection (DDR with 1 MB address alignment and OCM with 4 KB address alignment).
- TrustZone settings like Non Secure and Secure.
- Access settings like Read/Write, Read-only, and Write-Only. For LPD peripherals the Write-Only option is not available
- Secure Debug
- TZ settings for masters
- Lock Unprotected Address space

The following steps create security/protection settings:

1. Create a subsystem with any meaningful name using the "+" button as shown in [Figure 4-16](#).
2. To configure Isolation, enable the Isolation feature using **Enable Isolation button** as shown in [Figure 4-16](#).

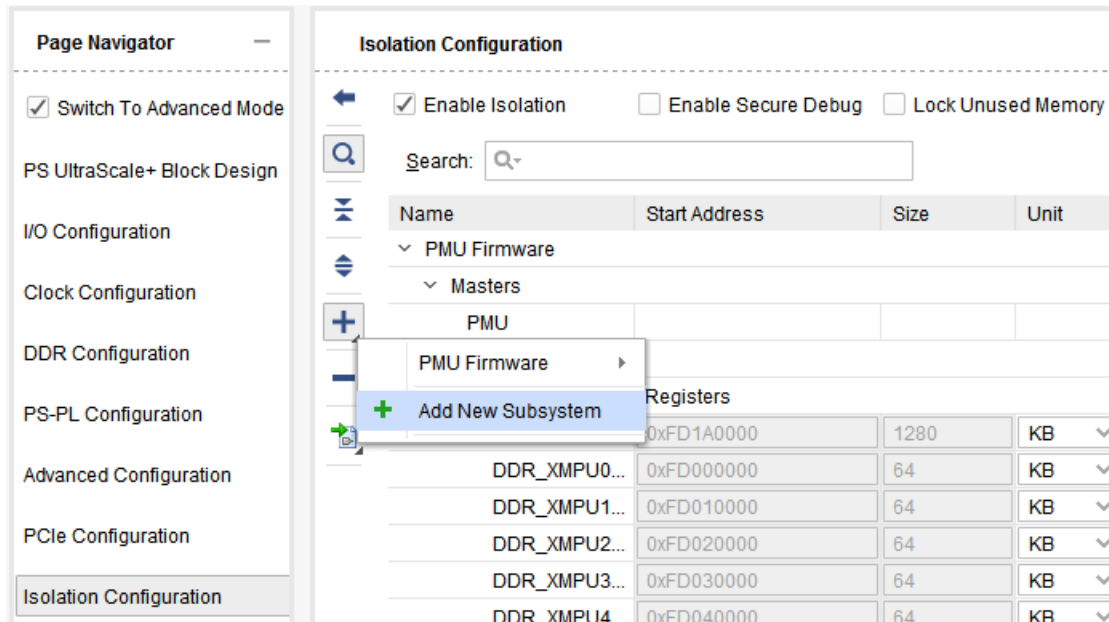

Figure 4-16: Creating a New Subsystem

3. Click **Add New Subsystem** and enter any name, for example, **APU_RPU Subsystem** and press **Enter**.

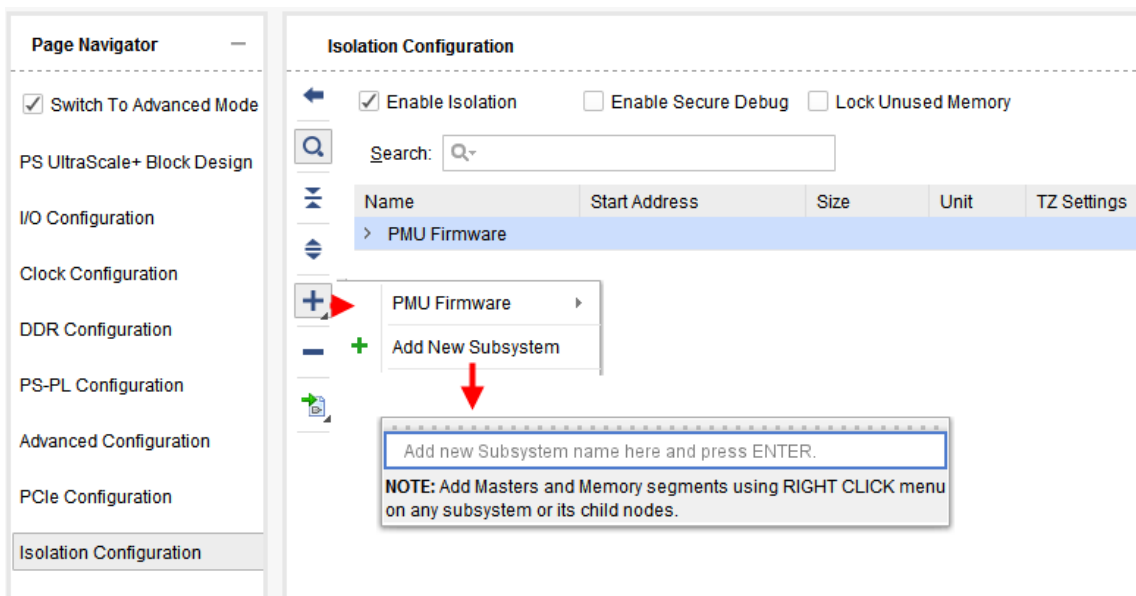

Figure 4-17: Naming New Subsystem

- Right-click **APU_RPU Subsystem** to add any peripheral, Memory, and Masters.

Example: Isolation settings to protect the following:

- Secure 4 MB of DDR memory from 0x00000000 with TZ as secure and Access settings as Read only to APU and RPU0
- Secure 12 KB of OCM memory from 0xFFFC0000 with TZ as secure and Access settings as Write only to APU and RPU0
- LPD peripherals UART 0, UART 1 with TZ as secure and Access settings as Read/Write only to APU and RPU0
- LPD peripherals SPI0, and SPI1 TZ as secure and Access settings as Read-Only to APU and RPU0

Perform the following steps in the PCW to create the previously described system:

- Open the PS Configuration Wizard (PCW), go to Isolation pane under Advanced Mode
- Click on + button and click **Add new Subsystem**, Enter APU subsystems and then Enter.
- Right-click **APU_RPU Subsystem** and then click **Add Master**. Select **APU,RPU0** from processors category as shown in [Figure 4-18](#).

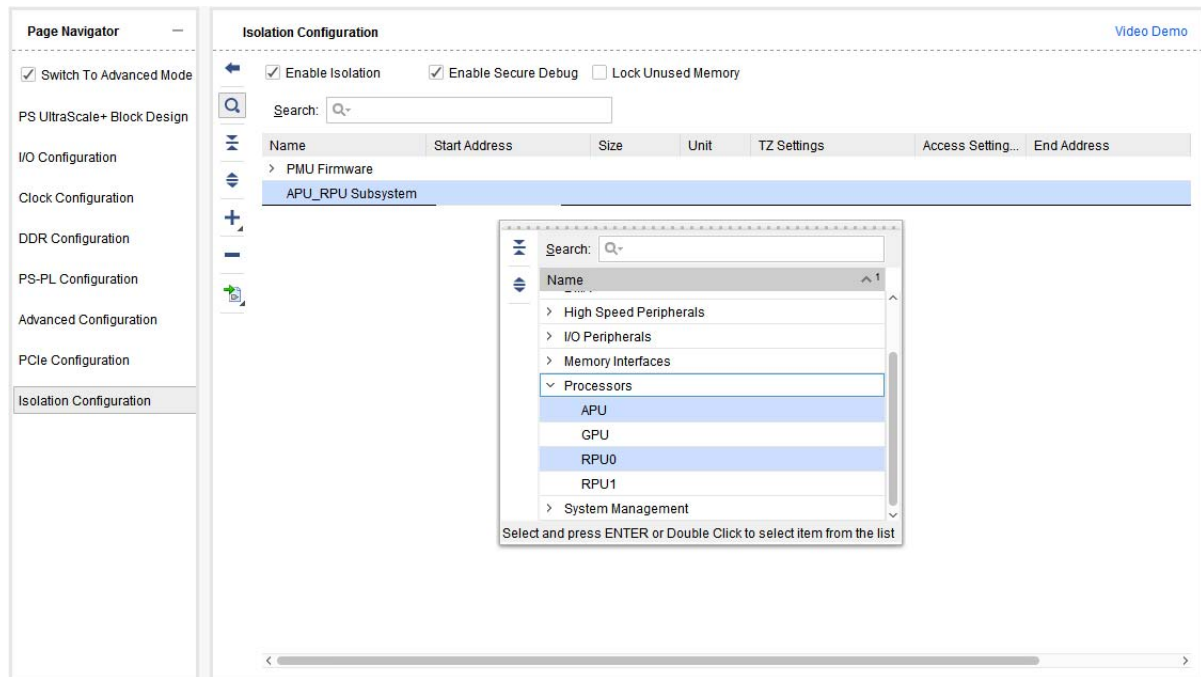

Figure 4-18: Adding Masters

- Right-click **APU_RPU Subsystem** and then click **Add Slaves**. Select **DDR_LOW** from Memory category.

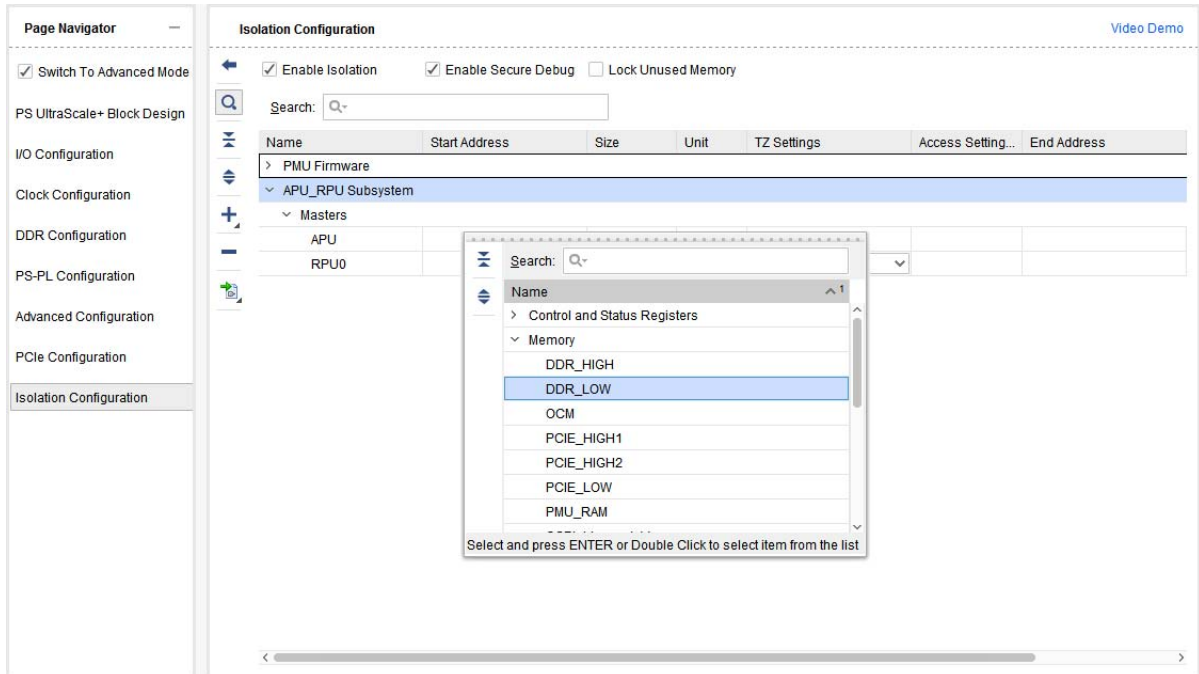

Figure 4-19: Adding DDR Segment

5. Enter the **Start Address** and size of the regions, that is 0x00000000 and 4 MB.
6. Set TZ as **Secure** from the **TZ Settings** drop-down list.

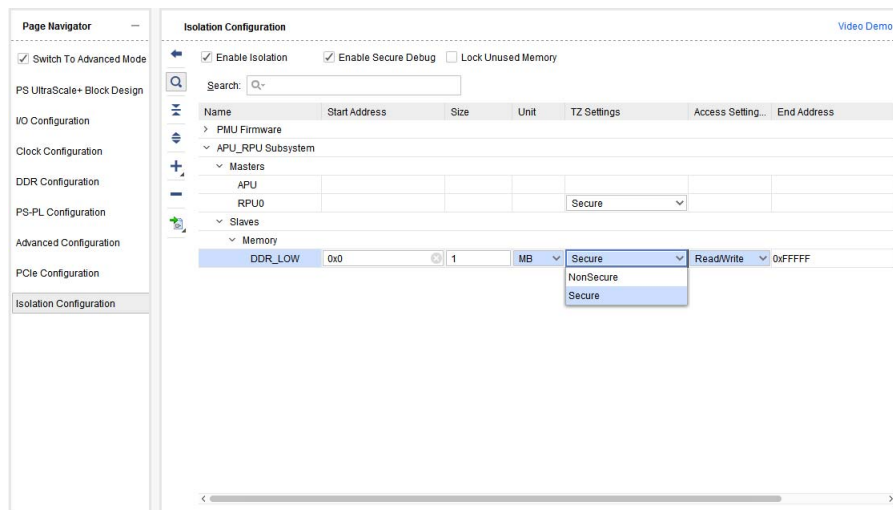

Figure 4-20: Setting TZ as Secure from the TZ Settings

7. Right-click **APU_RPU Subsystem** and then click **Add Slaves**. Select **OCM** from Memory category.

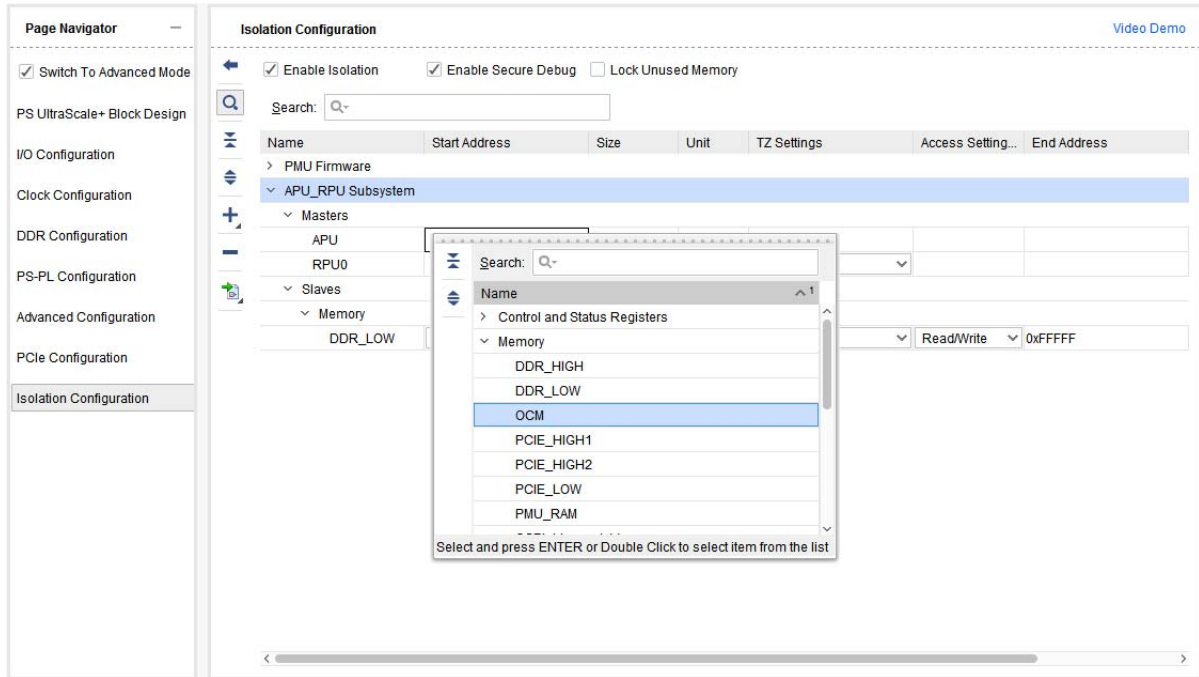

Figure 4-21: Selecting APU Subsystem and OCM

8. Right-click **APU_RPU Subsystem** and then click **Add Slaves**. Select **SWDT0**, **SWDT1**, **UART0** and **UART1** from Peripherals category.

Note: SWDT0, SWDT1, UART0 and UART1 must be first enabled in the I/O Configuration page before they will appear on the LPD list.

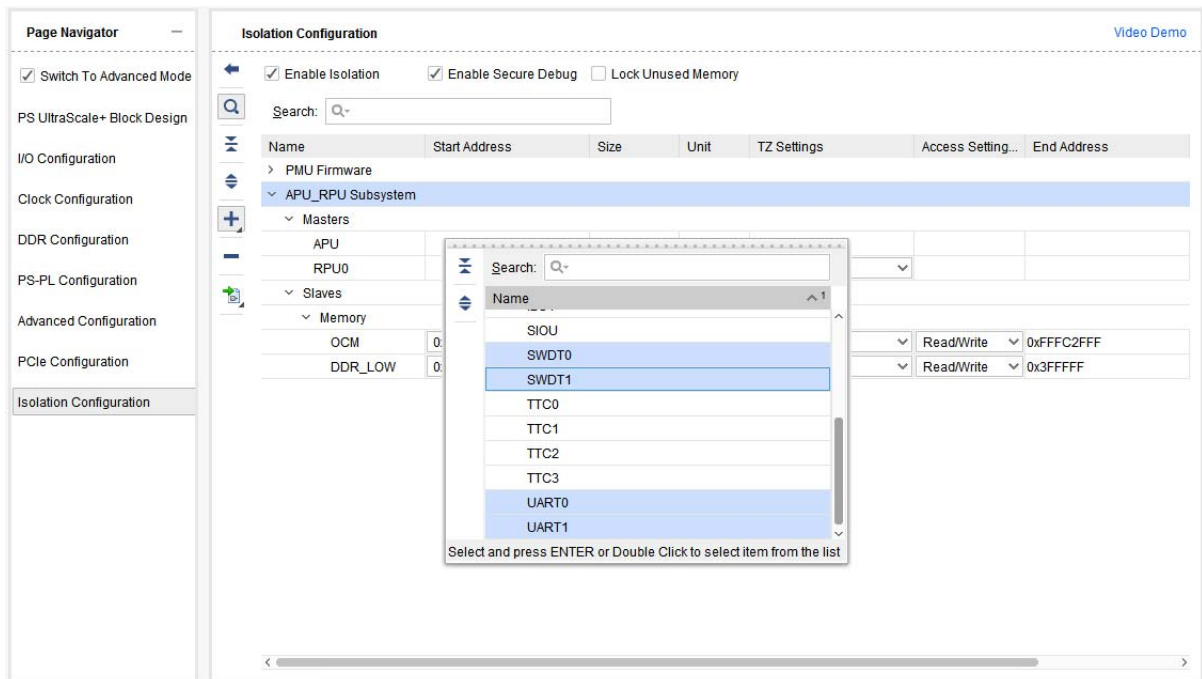

Figure 4-22: Selecting Peripherals

9. For **UART 0, UART 1**, set TZ as **Secure** and **Access Settings** as **Read/Write**.
10. For **SWDT0, SWDT1**, set TZ as **secure** and **Access Settings** as **Read-Only**.

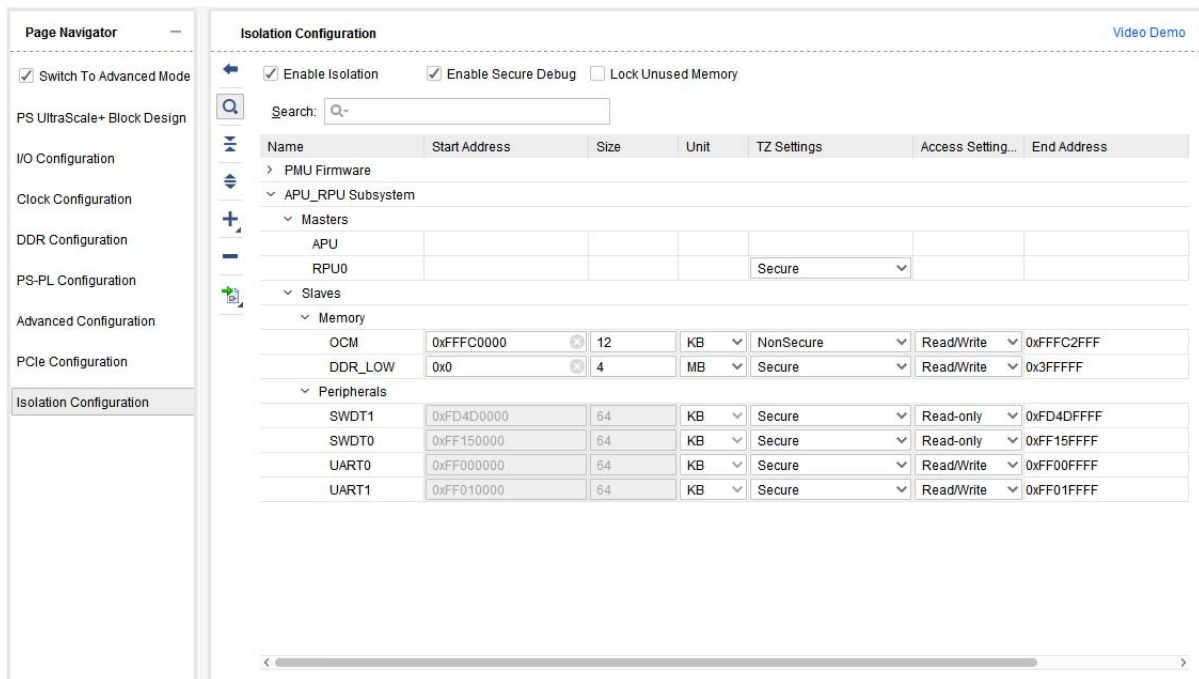

Figure 4-23: Access Settings as Read-Only

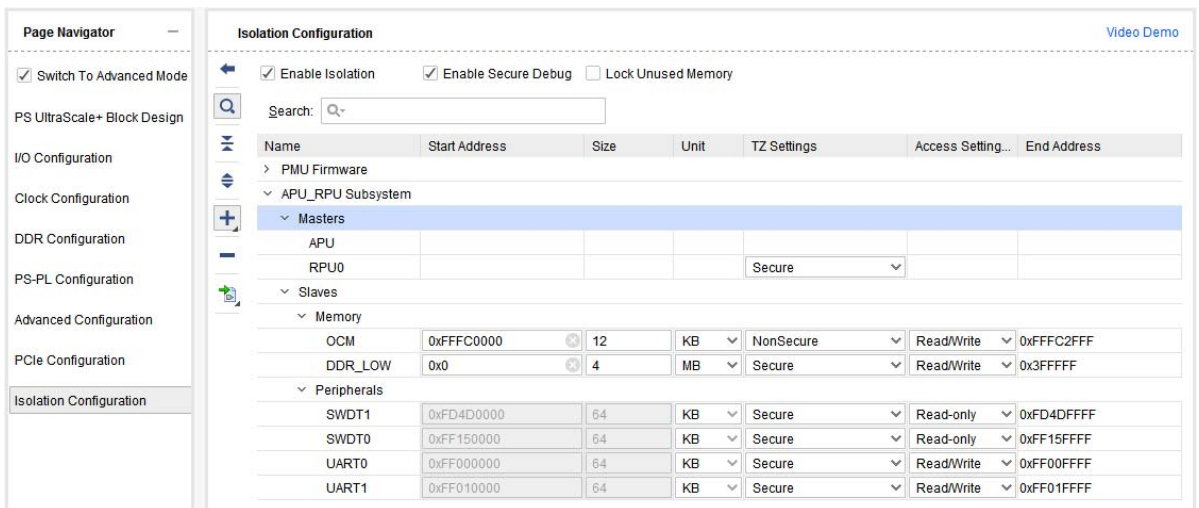

Figure 4-24: Isolation Configuration -- Masters List

Secure Debug: By default secure debug is enabled. It means that DAP and CoreSight™ are added as masters in all the subsystems so that debugging is allowed. For the design that is this release version, this **Secure Debug** should be disabled.

Lock Unprotected Address Space: Select this option to protect all the slaves/memory segments, control and status registers which are not mentioned or not part of any subsystems from masters. If a slave/memory segment, control and status register is not mentioned in Isolation, it cannot be accessed by any master.

PMU Firmware: By default, the PMU FW subsystem is added to Isolation configuration. You can modify/delete this subsystem as per your requirement.

You can create the PMU FW subsystem to achieve the following objectives:

1. Make PMU as a centralized processor to monitor any violations.
2. Give SLCR and control registers from all the masters and provide access to PMU only.
3. Protect XMPU and XPPU configuration registers from all other masters and provide access to PMU only.

Note: If you have your own schema to address all the above scenarios, you can have your own subsystems and can remove the PMU FW subsystem.

Known Limitations

By default, Isolation settings are partially applied by First Stage Boot Loader (FSBL). FSBL will not configure Isolation settings for Peripherals. Isolation settings for DDR and OCM XMPU only will be configured by FSBL through `psu_init`. To apply the Isolation settings completely, compile FSBL with `FSBL_PROT_BYPASS_EXCLUDE_VAL` symbol.

User Parameters

The core can be parameterized for individual applications. Parameters related to enabling interfaces or functions reflect the state of the Zynq UltraScale+ MPSoC configuration. The device configuration custom Vivado Integrated Design Environment (IDE) is available in the Vivado IP integrator and should be used to update the parameters mentioned in [Table C-1](#).

These parameter are updated in the IP integrator. Ports related to specific peripherals are either valid or invalid. Invalid ports are not visible. The IP integrator database uses these parameters to initialize associated PS registers in the `psu_init.tcl` or First Stage Boot Loader (FSBL). The FSBL enables you to configure the design as needed, including the PS and PL. By default, the JTAG interface is enabled to give you access to the PS and PL for test and debug purposes.

In batch mode, the core can be configured using the `set_property` Tcl Console command.

[Table C-1](#) in [Appendix C, User Parameters](#) shows the relationship between the fields in the Vivado IDE and the User Parameters (which can be viewed in the Tcl Console).

Output Generation

For details about common core output files, see “Generating IP Output Products” in the *Vivado Design Suite User Guide: Designing with IP* (UG896) [Ref 4].

The Vivado design tool exports the Hardware Platform Specification for your design to the Software Development Kit (SDK). The following four files are exported to SDK:

- The `system.hdf` file opens by default when SDK launches. The address map of your system read from this file is shown by default in the SDK window.
- The `psu_init.tcl`, `psu_init.c` and `psu_init.h` files contain the initialization code for the Zynq UltraScale+ MPSoC processing system and initialization settings for DDR, clocks, plls, and MIOs. SDK uses these settings when initializing the processing system so that applications can be run on top of the processing system.
 - `psu_init.tcl`: This Zynq UltraScale+ MPSoC Processor System initialization with the Tcl file is used for the device initialization Xilinx® System Debugger (XSDB) flow.
 - `psu_init.c`: Generated by the PS Configuration Wizard (PCW), this header file for the first stage boot loader (FSBL) contains proc of a `psu_init()` and the return values. The FSBL uses only this file, and it calls the `psu_init()` functions, and checks return values.
 - `psu_init.h`: Generated by the PCW, this file implements the `psu_init()`. This file also contains some testing code. This testing code enhances the testing performed by the PCW.

The supporting `.c` and `.h` files (described earlier) are also produced by the PCW.

The Zynq UltraScale MPSoC Processing System core overwrites all files when regenerated.

Constraining the Core

This section is not applicable for this core.

Required Constraints

This section is not applicable for this core.

Device, Package, and Speed Grade Selections

This section is not applicable for this core.

Clock Frequencies

This section is not applicable for this core.

Clock Management

This section is not applicable for this core.

Clock Placement

This section is not applicable for this core.

Banking

This section is not applicable for this core.

Transceiver Placement

This section is not applicable for this core.

I/O Standard and Placement

This section is not applicable for this core.

Simulation

AXI Verification IP for Zynq UltraScale+ MPSoC is not yet supported. This section is not applicable for this core.

Synthesis and Implementation

For details about synthesis and implementation, see the *Vivado Design Suite User Guide: Designing with IP* (UG896) [Ref 4].

Example Design

This chapter gives an example of how to set up a DDR Configuration.

The PS Configuration Wizard (PCW), provides you with the means to configure the DDR controller for your specific DDR Memory Part in an easy and intuitive manner. The following procedure demonstrates how to build a complete DDR configuration using the PCW and taking as an example Micron's MT41K1G8SN-125:A.

1. To access the DDR configuration, select the **DDR Configuration** from the PCW.

Looking at the DDR Configuration page, notice that it is split into four sections, these are:

- Clocking Options
- DDR Controller Options
- DDR Memory Options
- Other Options

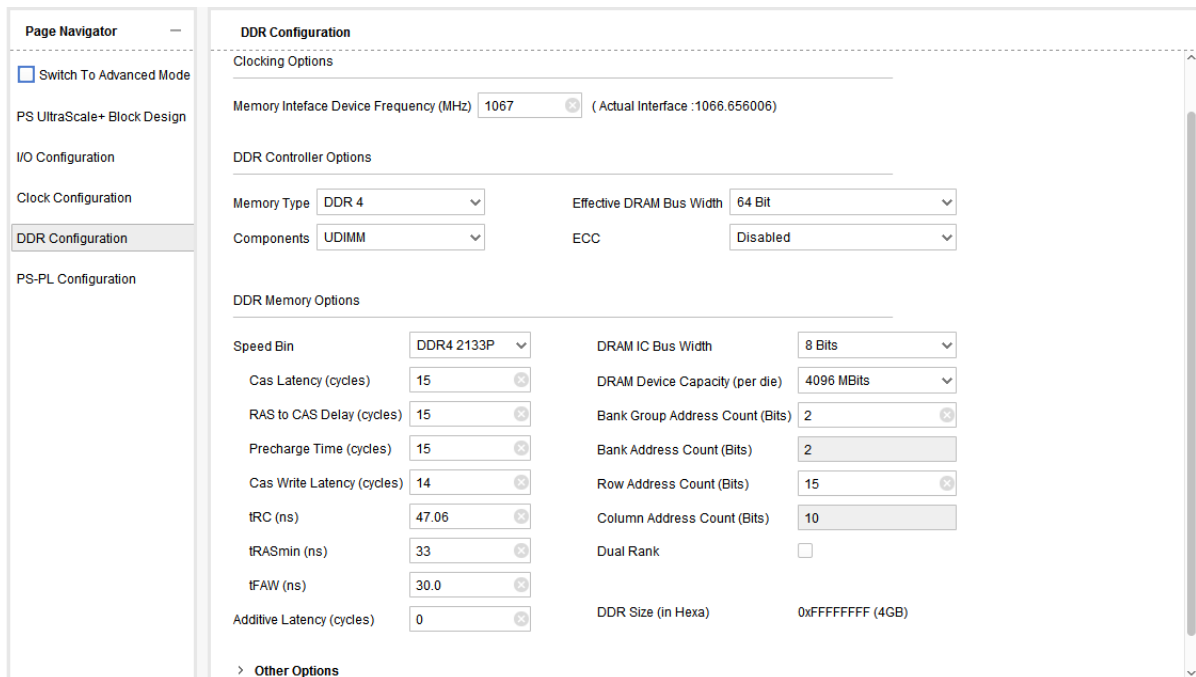

Figure 5-1: DDR Configuration

- From the DDR Configuration page, create a DDR Configuration using as an example the Micron MT41K1G8SN-125:A, which denotes a DDR3 device. For this example the focus is on the **DDR Controller Options** and **DDR Memory Options**.

Note: The Micron data sheet MT41K1G8SN-125:A content in Figure 5-2 through Figure 5-6 is provided with permission of Micron Technology Inc. [Ref 8]

DDR3L SDRAM

MT41K2G4 – 256 Meg x 4 x 8 banks

MT41K1G8 – 128 Meg x 8 x 8 banks

MT41K512M16 – 64 Meg x 16 x 8 banks

Description

DDR3L (1.35V) SDRAM is a low voltage version of the DDR3 (1.5V) SDRAM. Refer to a DDR3 (1.5V) SDRAM data sheet specifications when running in 1.5V compatible mode.

Features

- $V_{DD} = V_{DDQ} = 1.35V$ (1.283–1.45V)
- Backward compatible to $V_{DD} = V_{DDQ} = 1.5V \pm 0.075V$
 - Supports DDR3L devices to be backward compatible in 1.5V applications
- Differential bidirectional data strobe
- 8n-bit prefetch architecture
- Differential clock inputs (CK, CK#)
- 8 internal banks
- Nominal and dynamic on-die termination (ODT) for data, strobe, and mask signals
- Programmable CAS (READ) latency (CL)
- Programmable posted CAS additive latency (AL)
- Programmable CAS (WRITE) latency (CWL)
- Fixed burst length (BL) of 8 and burst chop (BC) of 4 (via the mode register set [MRS])
- Selectable BC4 or BL8 on-the-fly (OTF)
- Self refresh mode

- T_C of 0°C to +95°C
 - 64ms, 8192-cycle refresh at 0°C to +85°C
 - 32ms at +85°C to +95°C
- Self refresh temperature (SRT)
- Automatic self refresh (ASR)
- Write leveling
- Multipurpose register
- Output driver calibration

Options

Options	Marking
• Configuration	
– 2 Gig x 4	2G4
– 1 Gig x 8	1G8
– 512 Meg x 16	512M16
• PBGA package (Pb-free) – x4, x8	
– 78-ball (9mm x 13.2mm)	SN
• PBGA package (Pb-free) – x16	
– 96-ball (9mm x 14mm)	HA
• Timing – cycle time	
– 938ps @ CL = 14 (DDR3-2133)	-093
– 1.07ns @ CL = 13 (DDR3-1866)	-107
– 1.25ns @ CL = 11 (DDR3-1600)	-125
• Operating temperature	
– Commercial (0°C ≤ T_C ≤ +95°C)	None
– Industrial (-40°C ≤ T_C ≤ +95°C)	IT
• Revision	:A

Figure 5-2: Micron Data Sheet

Note: Content of Figure 5-2 used with permission by Micron Technology, Inc.
© 2010/09/04 Micron Technology, Inc., All Rights Reserved

- Examine the first page of the data sheet in Figure 5-2 and in particular the device name. You can identify the information that is required in order to fill in the **DDR Controller Options** and **DDR Memory Options** sections of the DDR Configuration Page.
 - The Device Part name provides a lot of information, for instance, **1G8** is the capacity of the device. In this case it is a 1 Gigabit Device by 8, which makes this an 8 Gigabit Device as shown as the first red rectangle Figure 5-2. There is a more in-depth calculation in the next steps.
 - The Device Part name also gives information as to the speed grade of the device. In this case it is designated as -125 as in 1.25 ns which is the maximum clock period in nanoseconds in this case and a CAS latency of 11 cycles for a DDR3-1600 Speed Bin as shown as the third red rectangle in Figure 5-2. You will see a more in-depth calculation in the next steps.
 - Using as an example the MT41K1G8SN-125:A device translates to the following.
 - Capacity = 1 GBits x 8 = 8 GBits

- Speed Grade = -125
1.25 ns @CL =11(DDR3-1600)
1.25 ns clock cycle == operating frequency of 800 MHz

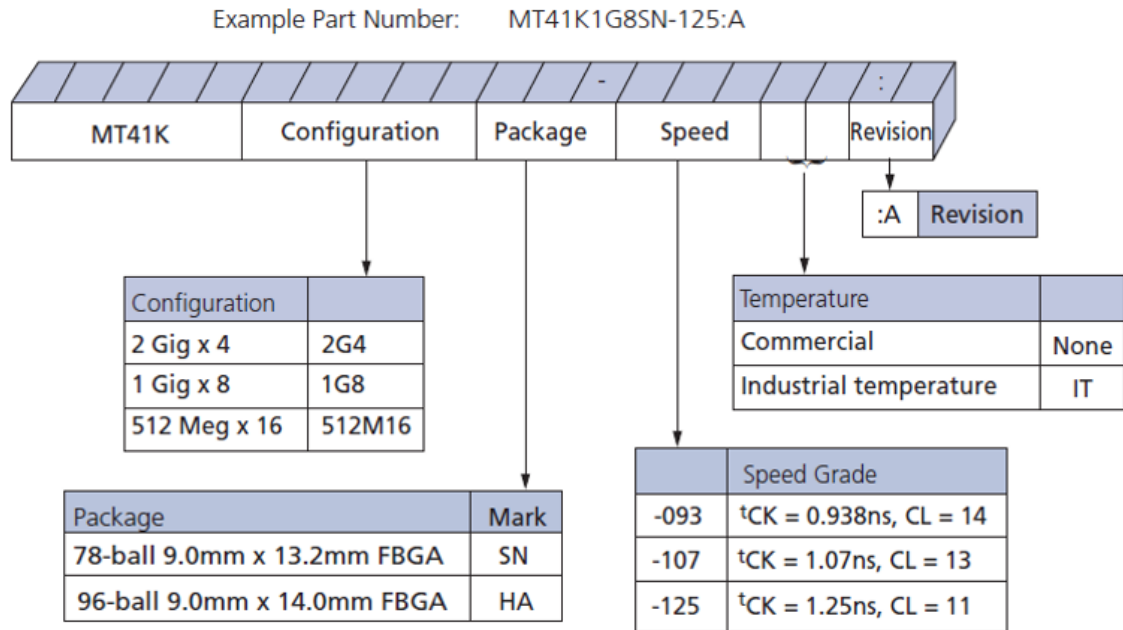

Figure 5-3: DDR Example Part Number

Note: Content of Figure 5-3 used with permission by Micron Technology, Inc.
© 2010/09/04 Micron Technology, Inc., All Rights Reserved

- o The Micron data sheet in Figure 5-3 shows an example part number and how to identify specific information of interest. For MT41K1G8SN-125:A:
 - Configuration is Row 2 (1 Gig x 8, 1G8)
 - Speed Grade is Row 3 (-125, t_{CLK} = 1.25ns, CL = 11)
 - Temperature is Row 2 (Industrial temperature, IT)

4. Examine the following figure. It is important to understand the addressing scheme.

Table 2: Addressing

Parameter	2 Gig x 4	1 Gig x 8	512 Meg x 16
Configuration	256 Meg x 4 x 8 banks	128 Meg x 8 x 8 banks	64 Meg x 16 x 8 banks
Refresh count	8K	8K	8K
Row address	64K (A[15:0])	64K (A[15:0])	64K (A[15:0])
Bank address	8 (BA[2:0])	8 (BA[2:0])	8 (BA[2:0])
Column address	4K (A[13,11, 9:0])	2K (A[11,9:0])	1K (A[9:0])
Page size	2KB	2KB	2KB

Figure 5-4: Addressing

Note: Content of [Figure 5-4](#) used with permission by Micron Technology, Inc.
 © 2010/09/04 Micron Technology, Inc., All Rights Reserved

The device capacity is expressed in bits. In this case the capacity is based on the addressable range of the Row, Column and Banks.

$$\text{Device Capacity} = (\text{Row Addressable Range} \times \text{Column Addressable Range} \times \text{Bank Addressable Range}) \times \text{Arrangement}$$

For MT41K1G8SN:A, Look at the second column of the Addressing table designated as 1 Gig x 8, this provides the following values:

- Row Addressable Range = A[15:0] = 2^{16}
- Column Addressable Range = A[11, 9:0] = 2^{11}
- Bank Addressable Range = BA[2:0] = 2^3 .
- Arrangement = 8 (i.e. 1Gig x 8)

With these values and the Device Capacity equation, gives the following:

- Device Capacity = $2^{16} \times 2^{11} \times 2^3 \times 8 = 8589934592 = 0x200000000 = 8\text{Gbits}$

5. Examine the Speed Bin and Operating Conditions in Figure 5-5.

Table 41: DDR3L-1600 Speed Bins

DDR3L-1600 Speed Bin		-125 ¹		Unit	Notes
CL- ^t RCD- ^t RP		11-11-11			
Parameter	Symbol	Min	Max		
Internal READ command to first data	^t AA	13.75	–	ns	
ACTIVATE to internal READ or WRITE delay time	^t RCD	13.75	–	ns	
PRECHARGE command period	^t RP	13.75	–	ns	
ACTIVATE-to-ACTIVATE or REFRESH command period	^t RC	48.75	–	ns	
ACTIVATE-to-PRECHARGE command period	^t RAS	35	9 x ^t REFI	ns	2
CL = 5	CWL = 5	^t CK (AVG)	3.0 3.3	ns	3
	CWL = 6, 7, 8	^t CK (AVG)	Reserved	ns	4
CL = 6	CWL = 5	^t CK (AVG)	2.5 3.3	ns	3
	CWL = 6	^t CK (AVG)	Reserved	ns	4
	CWL = 7, 8	^t CK (AVG)	Reserved	ns	4
CL = 7	CWL = 5	^t CK (AVG)	Reserved	ns	4
	CWL = 6	^t CK (AVG)	1.875 <2.5	ns	3
	CWL = 7	^t CK (AVG)	Reserved	ns	4
	CWL = 8	^t CK (AVG)	Reserved	ns	4
CL = 8	CWL = 5	^t CK (AVG)	Reserved	ns	4
	CWL = 6	^t CK (AVG)	1.875 <2.5	ns	3
	CWL = 7	^t CK (AVG)	Reserved	ns	4
	CWL = 8	^t CK (AVG)	Reserved	ns	4
CL = 9	CWL = 5, 6	^t CK (AVG)	Reserved	ns	4
	CWL = 7	^t CK (AVG)	1.5 <1.875	ns	3
	CWL = 8	^t CK (AVG)	Reserved	ns	4
CL = 10	CWL = 5, 6	^t CK (AVG)	Reserved	ns	4
	CWL = 7	^t CK (AVG)	1.5 <1.875	ns	3
	CWL = 8	^t CK (AVG)	Reserved	ns	4
CL = 11	CWL = 5, 6, 7	^t CK (AVG)	Reserved	ns	4
	CWL = 8	^t CK (AVG)	1.25 <1.5	ns	3
Supported CL settings		5, 6, 7, 8, 9, 10, 11		CK	
Supported CWL settings		5, 6, 7, 8		CK	

- Notes:
1. The -125 speed grade is backward compatible with 1333, CL = 9 (-15E) and 1066, CL = 7 (-187E).
 2. ^tREFI depends on T_{OPER}.
 3. The CL and CWL settings result in ^tCK requirements. When making a selection of ^tCK, both CL and CWL requirement settings need to be fulfilled.
 4. Reserved settings are not allowed.

Figure 5-5: DDR3L-1600 Speed Bins

Note: Content of Figure 5-5 used with permission by Micron Technology, Inc.
© 2010/09/04 Micron Technology, Inc., All Rights Reserved

Table 1: Key Timing Parameters

Speed Grade	Data Rate (MT/s)	Target ^t RCD- ^t RP-CL	^t RCD (ns)	^t RP (ns)	CL (ns)
-093 ^{1,2}	2133	14-14-14	13.09	13.09	13.09
-107 ¹	1866	13-13-13	13.91	13.91	13.91
-125	1600	11-11-11	13.75	13.75	13.75

Notes: 1. Backward compatible to 1600, CL = 11 (-125).
 2. Backward compatible to 1866, CL = 13 (-107).

Figure 5-6: DDR3L-1600 Speed Bins

Note: Content of [Figure 5-6](#) is used with permission by Micron Technology, Inc.
 © 2010/09/04 Micron Technology, Inc., All Rights Reserved

This following information can be derived by looking at both Table 41 in [Figure 5-5](#) and Table 1 in [Figure 5-6](#).

- The device supports 800 MHz (speed grade -125 [1/1.25ns]) operating frequency and because you are accessing a Double Data Rated (DDR) device the maximum transfer is 1600 Million Transfers per second. See Table 41. Row 1.
- Cas Latency (cycles) = Looking at Table 1 – 3rd Row, 3rd Column – Target ^tRCD – ^tRP - CL) CL = 11 cycles
- Cas Write Latency (CWL) == Using CL = 11 and looking at Table 41 we can determine that CLW is set at 8 cycles.
- RAS to DAS Delay (cycles) == ^tRCD/clock cycle = 13.75 ns/1.25 ns = 11 cycles
- ^tRC = 48.75ns
- ^tTRASmin = 35ns

6. With that information, you can now complete the DDR Configuration page.

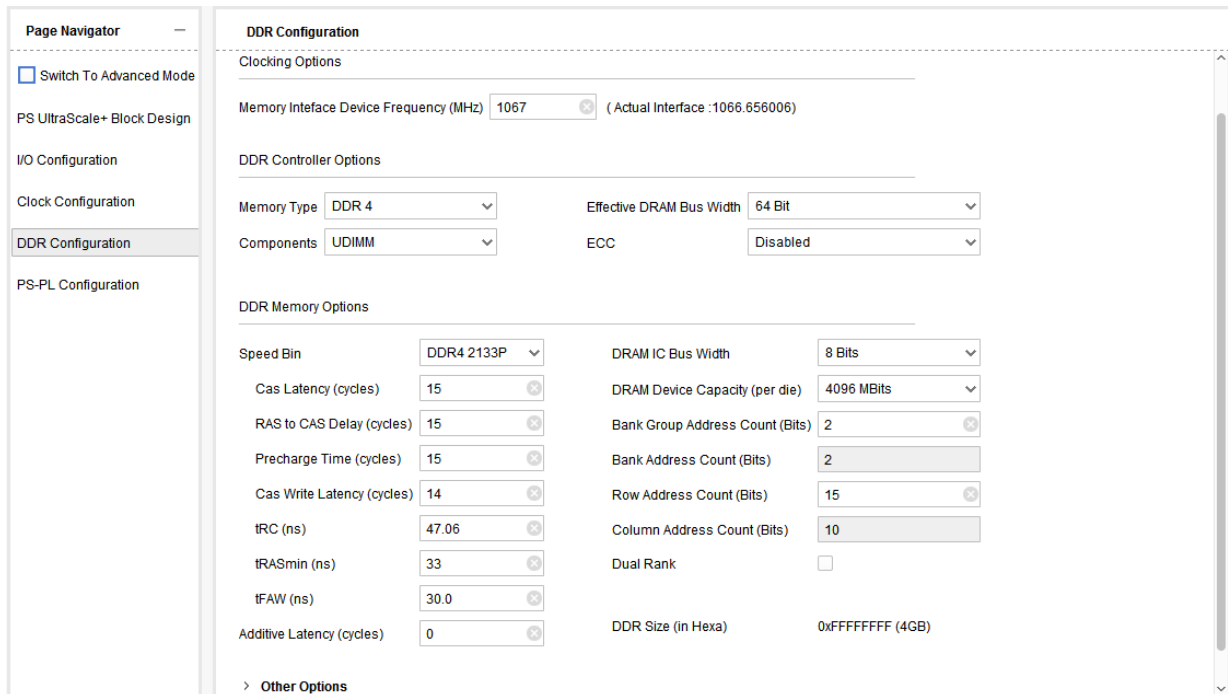

Figure 5-7: DDR Configuration

Following are descriptions of the DDR Controller Options:

- **Memory Type:** Type of memory interface. For more details about the individual resets, see the *Zynq UltraScale All Programmable MPSoC Technical Reference Manual* (UG1085) [Ref 1].
 - **Components** – Types of the components supported by the memory controller.
 - **Effective DRAM Bus Width** – Data width for DDR interface, not including ECC data width.
 - **ECC** – Enables Error correction code support. ECC is supported only for an effective data width of 16 bits.
7. Notice that the **Memory Interface Device Frequency** field has been auto-populated to keep the settings in sync.
 8. In the DDR Memory Options section, change the **Speed Bin** option. As stated previously this is a DDR3-1600 Device. Click and select **DDR3 1600K** from the drop down list.

Notice that PCW has auto-populated a number of fields such as:

- **CAS Latency:** Changed to 11 cycles
- **CAS Write Latency:** Changed to 8 cycles
- **Additive Latency:** Additive latency setting in memory clock cycles.

- **RAS to CAS Delay:** Changed to 11 cycles
- **Precharge Time:** Changed to 11 cycles.
- **tRC:** Set to 48.75 nanoseconds
- **tRASmin:** Set to 35 nanoseconds
- **tFAW:** Set to 30 nanoseconds

Even though these settings have been auto calculated you are still able to further fine tune them for your own specific part. Looking back at the settings that were calculated when reviewing the DDR from the Micron spreadsheet, notice that the values match.

9. Continue by reviewing the rest of the settings from the previous calculations. Looking at the **DRAM IC Bus Width**, select **8** as a 1G8 memory which implies a "by 8" arrangement as shown.
10. For **DRAM Device Capacity**, based on the previous calculations, select **8192 MBits** which is equal to 8 Gigabits as shown.
11. For **Rank Address Count (bits)** the Number of Rank address pins.
12. For **Bank Address Count (bits)** the Bank Addressable Range was 2 to the power of 3, therefore, keep **3** as the bits of **Bank Address Count (bits)**.
13. For the **Row Address Count (bits)** the Row Addressable Range was 2 to the power of 16, therefore, keep **16** as the bits for **Row Address Count (bits)**.
14. For the **Col Address Count (bits)** it was stated that the Column Addressable Range was 2 to the power of 11, therefore, select **11 bits** for **Column Address Count (bits)**.
15. Having concluded the calculations, click **OK** and then **Save the Project**.
16. For Other Options descriptions, see [Other Options in Chapter 4](#).

Upgrading

For changes to the Zynq® UltraScale+™ MPSoC core from Version 1.2 to Version 2.0, refer to Answer Record [67861](#) for more details.

Upgrading in the Vivado Design Suite

This section provides information about any changes to the user logic or port designations between core versions.

There are no changes in port definitions from v3.0 to v3.1. For detailed changes, please refer to the Change Log of Zynq UltraScale+ MPSoC IP.

Port Descriptions

The signals for the design are listed in the following tables.

Table B-1: SD/SDIO/eMMC: I/O Configuration

I/O Configuration	Slot Type		
	SD 2.0	SD 3.0	eMMC
sdioX_bus_pow	bus_pow	bus_pow	hwreset
sdioX_wp	wp	wp	N.A.
sdioX_cd_n	cd_n	cd_n	N.A.
sdioX_cmd_out	cmd_out	cmd_out	cmd_out
sdioX_clk_out	clk_out	clk_out	clk_out
sdioX_data_out[3:0]	data_out[3:0]	data_out[3:0]	data_out[3:0]
sdioX_data_out[4]	N.A.	sel	data_out[4]
sdioX_data_out[5]	N.A.	dir_cmd	data_out[5]
sdioX_data_out[6]	N.A.	dir_dat0	data_out[6]
sdioX_data_out[7]	N.A.	dir_dat1	data_out[7]

Table B-2: CAN0

Zynq UltraScale + MPSoC PS I/O Name	I/O	Description
can0_phy_tx	O	CAN bus transmit signal to first CAN physical-side interface (PHY)
can0_phy_rx	I	CAN bus receive signal from first CAN PHY

Table B-3: CAN1

Zynq UltraScale + MPSoC PS I/O Name	I/O	Description
can1_phy_tx	O	CAN bus transmit signal to second CAN PHY
can1_phy_rx	I	CAN bus receive signal from second CAN PHY

Table B-4: Event IO

Zynq UltraScale + MPSoC PS I/O Name	I/O	Description
pl_ps_eventi	I	Causes one or both CPUs to wake up from a wait for event (WFE) state.
ps_pl_evento	O	Asserted when one of the CPUs has executed the Send EVENT (SEV) instruction
ps_pl_standbywfe	O	CPU standby mode: asserted when a CPU is waiting for an event
ps_pl_standbywfi	O	CPU standby mode: asserted when a CPU is waiting for an interrupt.

Table B-5: FIFO_ENETO

Zynq UltraScale + MPSoC PS I/O Name	I/O	Description
enet0_tx_r_data_rdy	I	When set to logic 1. Indicates enough data is present in the external FIFO for Ethernet frame transmission to commence on the current packet.
enet0_tx_r_rd	O	Single tx_clk clock cycle wide active-High output requesting a 32-bit word of information from the external FIFO interface. Synchronous to the tx_clk clock domain.
enet0_tx_r_valid	I	Single tx_clk clock cycle wide active-High input indicating requested FIFO data is now valid. Validates the following inputs: tx_r_data[31:0], tx_r_sop, tx_r_eop, tx_r_err and tx_r_mod[1:0]
enet0_tx_r_data	I	FIFO data for transmission; this output is only valid while tx_r_valid is High.
enet0_tx_r_sop	I	Start of packet. Indicates the word received from the external FIFO interface is the first in a packet. This input is only valid while tx_r_valid is High.
enet0_tx_r_eop	I	End of packet. Indicates the word received from the external FIFO interface is the last in a packet. This input is only valid while tx_r_valid is High.
enet0_tx_r_err	I	Error, active-High input indicating the current packet contains an error. This signal is only valid while tx_r_valid is High and can be set at any time during the packet transfer.
enet0_tx_r_underflow	I	FIFO underflow. Indicates the transmit FIFO was empty when a read was attempted. This signal is only valid when a read has been attempted and the tx_r_valid signal has not yet been received.
enet0_tx_r_flushed	I	FIFO flush in progress. Indicates the transmit FIFO is currently removing any residue data content.
enet0_tx_r_control	I	tx_no_crc, set active-High at start of packet (SOP) to indicate the current frame is to be transmitted without crc being appended. This input is only valid while both tx_r_valid and tx_r_sop are High.
enet0_dma_tx_end_tog	O	Toggled to indicate that a frame has been completed and status is now valid on the tx_r_status output. Note that this signal is not activated when a frame is being retired due to a collision.

Table B-5: FIFO_ENETO (Cont'd)

Zynq UltraScale + MPSoC PS I/O Name	I/O	Description
enet0_dma_tx_status_tog	I	This signal must be toggled each time either tx_end_tog or collision_occured are activated. Indicates that the status has been acknowledged.
enet0_tx_r_status	O	[3]: fifo_underrun—status output indicating that the Ethernet media access control (MAC) transmitter has underrun due to one of the following conditions. Data under run indicated by tx_r_underflow input from the external FIFO interface during the last frame transfer. Reset once efifo_tx_status_tog changes logic state. [2]:collision_occured—status output Indicating that the frame in progress has suffered a collision and that re-transmission of the frame should take place. [1]: late_coll_occured—status output indicating that the frame in progress suffered a late collision and can be optionally retired. [0]:too_many_retires—status output indicating the frame in progress experienced excess collisions and was aborted.
enet0_rx_w_wr	O	Single rx_clk clock cycle wide active-High output indicating a write to the external FIFO interface.
enet0_rx_w_data	O	Received data for output to the external FIFO interface. This output is only when rx_w_wr is High.
enet0_rx_w_sop	O	Start of packet. Indicates the word output to the external FIFO interface is the first in a packet. This output is only valid when rx_w_wr is High.
enet0_rx_w_eop	O	End of packet. Indicates the word output to the external FIFO interface is the last in a packet. This output is only valid when rx_w_wr is High.

Table B-5: FIFO_ENETO (Cont'd)

Zynq UltraScale + MPSoC PS I/O Name	I/O	Description
enet0_rx_w_status	O	<p>Status signals, valid when rx_w_eop is High and rx_w_err is Low, otherwise driven to zero.</p> <p>[29]:Rx_w_type_match—indicates the received frame was matched on type ID register</p> <p>[28]:rx_w_add_match4—indicates the received frame was matched on specific address register4</p> <p>[27]:rx_w_add_match3—indicates the received frame was matched on specific address register3.</p> <p>[26]:rx_w_add_match3—indicates the received frame was matched on specific address register2.</p> <p>[25]:rx_w_add_match3—indicates the received frame was matched on specific address register1.</p> <p>[24]:rx_w_ext_match—indicates the received frame was matched externally by the eam input pin.</p> <p>[23]:rx_w_uni_hash_match—indicates the received frame was matched as a unicast hash frame.</p> <p>[22]:rx_w_mult_hash_match—indicates the received frame was matched as a multicast hash frame.</p> <p>[21]:rx_w_broadcast_frame—indicates the received frame is a broadcast frame.</p> <p>[20]:rx_w_prty_tagged—indicates a VLAN priority tag detected with received packet.</p> <p>[19:16]:rx_w_tci [3:0]—indicates VLAN priority of received packet.</p> <p>[15]:rx_w_vlan_tagged—indicates VLAN tag detected with received packet.</p> <p>[14]:rx_w_bad_frame—indicates received packet is bad, or the FIFO has overflowed.</p> <p>[13:0]: rx_w_frame_length—indicates number of bytes in received packet.</p>
enet0_rx_w_err	O	<p>Error, active-High output indicating the current packet contains error. This signal is only valid when both rx_w_wr and rx_w_eop are active-High. Rx_w_err is also set if the frame has not been matched by one of the filters.</p>
enet0_rx_w_overflow	I	<p>FIFO overflow. Indicates to the Ethernet MAC that the external RX FIFO has overflowed. The Ethernet MAC uses this signal for status reporting at the end of frame (EOF).</p>
enet0_rx_w_flush	O	<p>FIFO flush, active-High output indicating that the external RX FIFO must be cleared of all data.</p>

Table B-6: FIFO_ENET1

Zynq UltraScale + MPSoC PS I/O Name	I/O	Description
enet1_tx_r_data_rdy	I	When set to logic 1. Indicates enough data is present in the external FIFO for Ethernet frame transmission to commence on the current packet.
enet1_tx_r_rd	O	Single tx_clk clock cycle wide active-High output requesting a 32-bit word of information from the external FIFO interface. Synchronous to the tx_clk clock domain.
enet1_tx_r_valid	I	Single tx_clk clock cycle wide active-High input indicating requested FIFO data is now valid. Validates the following inputs: tx_r_data[31:0], tx_r_sop, tx_r_eop, tx_r_err and tx_r_mod[1:0].
enet1_tx_r_data	I	FIFO data for transmission. This output is only valid while tx_r_valid is High.
enet1_tx_r_sop	I	Start of packet. Indicates the word received from the external FIFO interface is the first in a packet. This input is only valid while tx_r_valid is High.
enet1_tx_r_eop	I	End of packet. Indicates the word received from the external FIFO interface is the last in a packet. This input is only valid while tx_r_valid is High.
enet1_tx_r_err	I	Error, active-High input indicating the current packet contains an error. This signal is only valid while tx_r_valid is High and can be set at any time during the packet transfer.
enet1_tx_r_underflow	I	FIFO underflow. Indicates the transmit FIFO was empty when a read was attempted. This signal is only valid when a read has been attempted and the tx_r_valid signal has not yet been received.
enet1_tx_r_flushed	I	FIFO flush in progress. Indicates the transmit FIFO is currently removing any residue data content.
enet1_tx_r_control	I	tx_no_crc, set active-High at SOP to indicate current frame is to be transmitted without crc being appended. This input is only valid while both tx_r_valid and tx_r_sop are High.
enet1_dma_tx_end_tog	O	Toggled to indicate that a frame has been completed and status is now valid on the tx_r_status output. Note that this signal is not activated when a frame is being retired due to a collision.
enet1_dma_tx_status_tog	I	This signal must be toggled each time either tx_end_tog or collision_occured are activated. Indicates that the status has been acknowledged.

Table B-6: FIFO_ENET1 (Cont'd)

Zynq UltraScale + MPSoC PS I/O Name	I/O	Description
enet1_tx_r_status	O	<p>[3]: fifo_underrun—status output indicating that the Ethernet MAC transmitter has underrun due to one of the following conditions. Data under run indicated by tx_r_underflow input from the external FIFO interface during the last frame transfer. Reset once efifo_tx_status_tog changes logic state.</p> <p>[2]:collision_occured—status output</p> <p>Indicating that the frame in progress has suffered a collision and that re-transmission of the frame should take place.</p> <p>[1]: late_coll_occured—status output indicating that the frame in progress suffered a late collision and can be optionally retired.</p> <p>[0]:too_many_retries—status output indicating the frame in progress experienced excess collisions and was aborted.</p>
enet1_rx_w_wr	O	Single rx_clk clock cycle wide active-High output indicating a write to the external FIFO interface.
enet1_rx_w_data	O	Received data for output to the external FIFO interface. This output is only when rx_w_wr is High.
enet1_rx_w_sop	O	Start of packet. Indicates the word output to the external FIFO interface is the first in a packet. This output is only valid when rx_w_wr is High.
enet1_rx_w_eop	O	End of packet. Indicates the word output to the external FIFO interface is the last in a packet. This output is only valid when rx_w_wr is High.

Table B-6: FIFO_ENET1 (Cont'd)

Zynq UltraScale + MPSoC PS I/O Name	I/O	Description
enet1_rx_w_status	O	<p>Status signals, valid when rx_w_eop is High and rx_w_err is Low, otherwise driven to zero.</p> <p>[29]:rx_w_type_match—indicates the received frame was matched on type ID register.</p> <p>[28]:rx_w_add_match4—indicates the received frame was matched on specific address register4.</p> <p>[27]:rx_w_add_match3—indicates the received frame was matched on specific address register3.</p> <p>[26]:rx_w_add_match3—indicates the received frame was matched on specific address register2.</p> <p>[25]:rx_w_add_match3—indicates the received frame was matched on specific address register1.</p> <p>[24]:rx_w_ext_match—indicates the received frame was matched externally by the eam input pin.</p> <p>[23]:rx_w_uni_hash_match—indicates the received frame was matched as a unicast hash frame.</p> <p>[22]:rx_w_mult_hash_match—indicates the received frame was matched as a multicast hash frame.</p> <p>[21]:rx_w_broadcast_frame—indicates the received frame is a broadcast frame.</p> <p>[20]:rx_w_prty_tagged—indicates a VLAN priority tag detected with received packet.</p> <p>[19:16]:rx_w_tci [3:0]—indicates VLAN priority of received packet.</p> <p>[15]:rx_w_vlan_tagged—indicates VLAN tag detected with received packet.</p> <p>[14]:rx_w_bad_frame—indicates received packet is bad or the FIFO has overflowed.</p> <p>[13:0]: rx_w_frame_length—indicates number of bytes in received packet.</p>
enet1_rx_w_err	O	<p>Error, active-High output indicating the current packet contains an error. This signal is only valid when both rx_w_wr and rx_w_eop are active-High. rx_w_err is also set if the frame has not been matched by one of the filters.</p>
enet1_rx_w_overflow	I	<p>FIFO overflow. Indicates to the Ethernet MAC that the external RX FIFO has overflowed. The Ethernet MAC uses this signal for status reporting at the EOF.</p>
enet1_rx_w_flush	O	<p>FIFO flush, active-High output indicating that the external RX FIFO must be cleared of all data.</p>

Table B-7: FIFO_ENET2

Zynq UltraScale + MPSoC PS I/O Name	I/O	Description
enet2_tx_r_data_rdy	I	When set to logic 1. Indicates enough data is present in the external FIFO for Ethernet frame transmission to commence on the current packet.
enet2_tx_r_rd	O	Single tx_clk clock cycle wide active-High output requesting a 32-bit word of information from the external FIFO interface. Synchronous to the tx_clk clock domain.
enet2_tx_r_valid	I	Single tx_clk clock cycle wide active-High input indicating requested FIFO data is now valid. Validates the following inputs: tx_r_data[31:0], tx_r_sop, tx_r_eop, tx_r_err and tx_r_mod[1:0].
enet2_tx_r_data	I	FIFO data for transmission. This output is only valid while tx_r_valid is High.
enet2_tx_r_sop	I	Start of packet. Indicates the word received from the external FIFO interface is the first in a packet. This input is only valid while tx_r_valid is High.
enet2_tx_r_eop	I	End of packet. Indicates the word received from the external FIFO interface is the last in a packet. This input is only valid while tx_r_valid is High.
enet2_tx_r_err	I	Error. Active-High input indicating the current packet contains an error. This signal is only valid while tx_r_valid is High and can be set at any time during the packet transfer.
enet2_tx_r_underflow	I	FIFO underflow. Indicates the transmit FIFO was empty when a read was attempted. This signal is only valid when a read has been attempted and the tx_r_valid signal has not yet been received.
enet2_tx_r_flushed	I	FIFO flush in progress. Indicates the transmit FIFO is currently removing any residue data content.
enet2_tx_r_control	I	tx_no_crc. Set active-High at SOP to indicate current frame is to be transmitted without crc being appended. This input is only valid while both tx_r_valid and tx_r_sop are High.
enet2_dma_tx_end_tog	O	Toggled to indicate that a frame has been completed and status is now valid on the tx_r_status output. Note that this signal is not activated when a frame is being retired due to a collision.
enet2_dma_tx_status_tog	I	This signal must be toggled each time either tx_end_tog or collision_occured are activated. Indicates that the status has been acknowledged.

Table B-7: FIFO_ENET2 (Cont'd)

Zynq UltraScale + MPSoC PS I/O Name	I/O	Description
enet2_tx_r_status	O	<p>[3]: fifo_underrun—status output indicating that the Ethernet MAC transmitter has under run due to one of the following conditions. Data under run indicated by tx_r_underflow input from the external FIFO interface during the last frame transfer. Reset once efifo_tx_status_tog changes logic state.</p> <p>[2]:collision_occured—status output</p> <p>Indicating that the frame in progress has suffered a collision and that re-transmission of the frame should take place.</p> <p>[1]: late_coll_occured—status output indicating that the frame in progress suffered a late collision and can be optionally retired.</p> <p>[0]:too_many_retries—status output indicating the frame in progress experienced excess collisions and was aborted.</p>
enet2_rx_w_wr	O	Single rx_clk clock cycle wide active-High output indicating a write to the external FIFO interface.
enet2_rx_w_data	O	Received data for output to the external FIFO interface. This output is only when rx_w_wr is High.
enet2_rx_w_sop	O	Start of packet. Indicates the word output to the external FIFO interface is the first in a packet. This output is only valid when rx_w_wr is High.
enet2_rx_w_eop	O	End of packet. Indicates the word output to the external FIFO interface is the last in a packet. This output is only valid when rx_w_wr is High.

Table B-7: FIFO_ENET2 (Cont'd)

Zynq UltraScale + MPSoC PS I/O Name	I/O	Description
enet2_rx_w_status	O	<p>Status signals. Valid when rx_w_eop is High and rx_w_err is Low, otherwise driven to zero.</p> <p>[29]:Rx_w_type_match—indicates the received frame was matched on type ID register</p> <p>[28]:rx_w_add_match4—indicates the received frame was matched on specific address register4</p> <p>[27]:rx_w_add_match3—indicates the received frame was matched on specific address register3.</p> <p>[26]:rx_w_add_match3—indicates the received frame was matched on specific address register2.</p> <p>[25]:rx_w_add_match3—indicates the received frame was matched on specific address register1.</p> <p>[24]:rx_w_ext_match—indicates the received frame was matched externally by the eam input pin.</p> <p>[23]:rx_w_uni_hash_match—indicates the received frame was matched as a unicast hash frame.</p> <p>[22]:rx_w_mult_hash_match—indicates the received frame was matched as a multicast hash frame.</p> <p>[21]:rx_w_broadcast_frame—indicates the received frame is a broadcast frame.</p> <p>[20]:rx_w_prty_tagged—indicates a VLAN priority tag detected with received packet.</p> <p>[19:16]:rx_w_tci [3:0]—indicates VLAN priority of received packet.</p> <p>[15]:rx_w_vlan_tagged—indicates VLAN tag detected with received packet.</p> <p>[14]:rx_w_bad_frame—indicates received packet is bad, or the FIFO has overflowed.</p> <p>[13:0]: rx_w_frame_length—indicates number of bytes in received packet.</p>
enet2_rx_w_err	O	<p>Error, active-High output indicating the current packet contains error. This signal is only valid when both rx_w_wr and rx_w_eop are active-High. Rx_w_err is also set if the frame has not been matched by one of the filters.</p>
enet2_rx_w_overflow	I	<p>FIFO overflow. Indicates to the Ethernet MAC that the external RX FIFO has overflowed. The Ethernet MAC uses this signal for status reporting at the EOF.</p>
enet2_rx_w_flush	O	<p>FIFO flush, active-High output indicating that the external RX FIFO must be cleared of all data.</p>

Table B-8: FIFO_ENET3

Zynq UltraScale + MPSoC PS I/O Name	I/O	Description
enet3_tx_r_data_rdy	I	When set to logic 1, indicates enough data is present in the external FIFO for Ethernet frame transmission to commence on the current packet.
enet3_tx_r_rd	O	Single tx_clk clock cycle wide. Active-High output requesting a 32-bit word of information from the external FIFO interface. Synchronous to the tx_clk clock domain.
enet3_tx_r_valid	I	Single tx_clk clock cycle wide. Active-High input indicating requested FIFO data is now valid. Validates the following inputs: tx_r_data[31:0], tx_r_sop, tx_r_eop, tx_r_err and tx_r_mod[1:0]
enet3_tx_r_data	I	FIFO data for transmission. This output is only valid while tx_r_valid is High.
enet3_tx_r_sop	I	Start of packet. Indicates the word received from the external FIFO interface is the first in a packet. This input is only valid while tx_r_valid is High.
enet3_tx_r_eop	I	End of packet. Indicates the word received from the external FIFO interface is the last in a packet. This input is only valid while tx_r_valid is High.
enet3_tx_r_err	I	Error. Active-High input indicating the current packet contains an error. This signal is only valid while tx_r_valid is High and can be set at any time during the packet transfer.
enet3_tx_r_underflow	I	FIFO underflow. Indicates the transmit FIFO was empty when a read was attempted. This signal is only valid when a read has been attempted and the tx_r_valid signal has not yet been received.
enet3_tx_r_flushed	I	FIFO flush in progress. Indicates the transmit FIFO is currently removing any residue data content.
enet3_tx_r_control	I	tx_no_crc. Set active-High at SOP to indicate current frame is to be transmitted without crc being appended. This input is only valid while both tx_r_valid and tx_r_sop are High.
enet3_dma_tx_end_tog	O	Toggled to indicate that a frame has been completed and status is now valid on the tx_r_status output. Note that this signal is not activated when a frame is being retired due to a collision.
enet3_dma_tx_status_tog	I	This signal must be toggled each time either tx_end_tog or collision_occured are activated. Indicates that the status has been acknowledged.

Table B-8: FIFO_ENET3 (Cont'd)

Zynq UltraScale + MPSoC PS I/O Name	I/O	Description
enet3_tx_r_status	O	<p>[3]: fifo_underrun—status output indicating that the Ethernet MAC transmitter has under-run due to one of the following conditions. Data under run indicated by tx_r_underflow input from the external FIFO interface during the last frame transfer. Reset once efifo_tx_status_tog changes logic state.</p> <p>[2]:collision_occured—status output</p> <p>Indicating that the frame in progress has suffered a collision and that re-transmission of the frame should take place.</p> <p>[1]: late_coll_occured—status output indicating that the frame in progress suffered a late collision and can be optionally retired.</p> <p>[0]:too_many_retires—status output indicating the frame in progress experienced excess collisions and was aborted.</p>
enet3_rx_w_wr	O	Single rx_clk clock cycle wide active-High output indicating a write to the external FIFO interface.
enet3_rx_w_data	O	Received data for output to the external FIFO interface. This output is only when rx_w_wr is High.
enet3_rx_w_sop	O	Start of packet. Indicates the word output to the external FIFO interface is the first in a packet. This output is only valid when rx_w_wr is High.
enet3_rx_w_eop	O	End of packet. Indicates the word output to the external FIFO interface is the last in a packet. This output is only valid when rx_w_wr is High.

Table B-8: FIFO_ENET3 (Cont'd)

Zynq UltraScale + MPSoC PS I/O Name	I/O	Description
enet3_rx_w_status	O	<p>Status signals. Valid when rx_w_eop is High and rx_w_err is Low, otherwise driven to zero.</p> <p>[29]:rx_w_type_match—indicates the received frame was matched on type ID register.</p> <p>[28]:rx_w_add_match4—indicates the received frame was matched on specific address register4.</p> <p>[27]:rx_w_add_match3—indicates the received frame was matched on specific address register3.</p> <p>[26]:rx_w_add_match3—indicates the received frame was matched on specific address register2.</p> <p>[25]:rx_w_add_match3—indicates the received frame was matched on specific address register1.</p> <p>[24]:rx_w_ext_match—indicates the received frame was matched externally by the eam input pin.</p> <p>[23]:rx_w_uni_hash_match—indicates the received frame was matched as a unicast hash frame.</p> <p>[22]:rx_w_mult_hash_match—indicates the received frame was matched as a multicast hash frame.</p> <p>[21]:rx_w_broadcast_frame—indicates the received frame is a broadcast frame.</p> <p>[20]:rx_w_prty_tagged—indicates a VLAN priority tag detected with received packet.</p> <p>[19:16]:rx_w_tci [3:0]—indicates VLAN priority of received packet.</p> <p>[15]:rx_w_vlan_tagged—indicates VLAN tag detected with received packet.</p> <p>[14]:rx_w_bad_frame—indicates received packet is bad, or the FIFO has overflowed.</p> <p>[13:0]: rx_w_frame_length—indicates number of bytes in received packet.</p>
enet3_rx_w_err	O	<p>Error. Active-High output indicating the current packet contains error. This signal is only valid when both rx_w_wr and rx_w_eop are active-High. Rx_w_err is also set if the frame has not been matched by one of the filters.</p>
enet3_rx_w_overflow	I	<p>FIFO overflow. Indicates to the Ethernet MAC that the external RX FIFO has overflowed. The Ethernet MAC uses this signal for status reporting at the EOF.</p>
enet3_rx_w_flush	O	<p>FIFO flush, active-High output indicating that the external RX FIFO must be cleared of all data.</p>

Table B-9: FTM

Zynq UltraScale + MPSoC PS I/O Name	I/O	Description
pl_ps_trigack	I	Trigger acknowledgement from PL
pl_ps_trigger	O	Trigger output to PL
ps_pl_trigack	O	Trigger acknowledgement to PL
ps_pl_trigger	I	Trigger input from PL
gpo	O	General purpose output
gpi	I	General purpose input

Table B-10: TSU

Zynq UltraScale + MPSoC PS I/O Name	I/O	Description
emio_enetx_tsu_inc_ctrl	I	TSU increment control
fmio_gem_tsu_clk_from_pl	I	TSU clock source from PL
emio_enetx_tsu_timer_cmp_val	O	TSU timer compare value
emio_enet0_enet_tsu_timer_cnt	O	TSU timer count value

Table B-11: GMII_ENET0

Zynq UltraScale + MPSoC PS I/O Name	I/O	Description
enet0_gmii_rx_clk	I	GEM 0 Receive clock to the system clock generator
enet0_speed_mode	O	Indicates speed and external interface that the GEM is currently configured to use to the system clock generator
enet0_gmii_crs	I	Carrier sense from the PHY
enet0_gmii_col	I	Collision detect from the PHY
enet0_gmii_rxd	I	Receive data from the PHY
enet0_gmii_rx_er	I	Receive error signal from the PHY
enet0_gmii_rx_dv	I	Receive data valid signal from the PHY
enet0_gmii_tx_clk	I	GEM 0 Transmit clock from the system clock generator
enet0_gmii_txd	O	Transmit data to the PHY
enet0_gmii_tx_en	O	Transmit enable to the PHY
enet0_gmii_tx_er	O	Transmit error signal to the PHY. Asserted if the DMA block fails to fetch data from memory during frame transmission.

Table B-12: GMII_ENET1

Zynq UltraScale + MPSoC PS I/O Name	I/O	Description
enet1_gmii_rx_clk	I	GEM 1 Receive clock to the system clock generator
enet1_speed_mode	O	Indicates speed and external interface that the GEM is currently configured to use to the system clock generator
enet1_gmii_crs	I	Carrier sense from the PHY
enet1_gmii_col	I	Collision detect from the PHY
enet1_gmii_rxd	I	Receive data from the PHY
enet1_gmii_rx_er	I	Receive error signal from the PHY
enet1_gmii_rx_dv	I	Receive data valid signal from the PHY
enet1_gmii_tx_clk	I	GEM 1 Transmit clock from the system clock generator
enet1_gmii_txd	O	Transmit data to the PHY
enet1_gmii_tx_en	O	Transmit enable to the PHY
enet1_gmii_tx_er	O	Transmit error signal to the PHY. Asserted if the DMA block fails to fetch data from memory during frame transmission

Table B-13: GMII_ENET2

Zynq UltraScale + MPSoC PS I/O Name	I/O	Description
enet2_gmii_rx_clk	I	GEM 2 Receive clock to the system clock generator
enet2_speed_mode	O	Indicates speed and external interface that the GEM is currently configured to use to the system clock generator
enet2_gmii_crs	I	Carrier sense from the PHY
enet2_gmii_col	I	Collision detect from the PHY
enet2_gmii_rxd	I	Receive data from the PHY
enet2_gmii_rx_er	I	Receive error signal from the PHY
enet2_gmii_rx_dv	I	Receive data valid signal from the PHY
enet2_gmii_tx_clk	I	GEM 3 Transmit clock from the system clock generator
enet2_gmii_txd	O	Transmit data to the PHY
enet2_gmii_tx_en	O	Transmit enable to the PHY
enet2_gmii_tx_er	O	Transmit error signal to the PHY. Asserted if the DMA block fails to fetch data from memory during frame transmission.

Table B-14: GMII_ENET3

Zynq UltraScale + MPSoC PS I/O Name	I/O	Description
enet3_gmii_rx_clk	I	GEM 3 Receive clock to the system clock generator
enet3_speed_mode	O	Indicates speed and external interface that the GEM is currently configured to use to the system clock generator.
enet3_gmii_crs	I	Carrier sense from the PHY
enet3_gmii_col	I	Collision detect from the PHY
enet3_gmii_rxd	I	Receive data from the PHY
enet3_gmii_rx_er	I	Receive error signal from the PHY
enet3_gmii_rx_dv	I	Receive data valid signal from the PHY
enet3_gmii_tx_clk	I	GEM 3 Transmit clock from the system clock generator
enet3_gmii_txd	O	Transmit data to the PHY
enet3_gmii_tx_en	O	Transmit enable to the PHY
enet3_gmii_tx_er	O	Transmit error signal to the PHY. Asserted if the DMA block fails to fetch data from memory during frame transmission.

Table B-15: GPIO_0

Zynq UltraScale + MPSoC PS I/O Name	I/O	Description
gpio_i	I	GPIO port input
gpio_o	O	GPIO port output
gpio_t	O	3-state enable signal for GPIO port

Table B-16: IIC0

Zynq UltraScale + MPSoC PS I/O Name	I/O	Description
i2c0_scl_i	I	Actual state of the external serial clock (SCL) clock signal
i2c0_scl_o	O	Clock level to be placed on SCL pin
i2c0_scl_t	O	3-state enable for the SCL output buffer. This signal has a direct connection to i2c0_scl_oe.
i2c0_sda_i	I	Actual state of the external serial data (SDA) signal
i2c0_sda_o	O	Data bit to be placed on external SDA signal
i2c0_sda_t	O	3-state enable for the SDA output buffer This signal has a direct connection to i2c0_sda_oe.

Table B-17: IIC1

Zynq UltraScale + MPSoC PS I/O Name	I/O	Description
i2c1_scl_i	I	Actual state of the external SCL clock signal
i2c1_scl_o	O	Clock level to be placed on SCL pin
i2c1_scl_t	O	3-state enable for the SCL output buffer. This signal has a direct connection to i2c1_scl_oe.
i2c1_sda_i	I	Actual state of the external SDA signal
i2c1_sda_o	O	Data bit to be placed on external SDA signal
i2c1_sda_t	O	3-state enable for the SDA output buffer. This signal has a direct connection to i2c1_sda_oe.

Table B-18: MDIO_ENETO

Zynq UltraScale + MPSoC PS I/O Name	I/O	Description
enet0_mdio_mdc	O	Management data clock to pin
enet0_mdio_i	I	Management data input from MDIO pin
enet0_mdio_o	O	Management data output to MDIO pin
enet0_mdio_t	O	3-state enable to MDIO pin, active-Low. At the top-level the three MDIO pins are all used to drive a single 3-state pin.

Table B-19: MDIO_ENET1

Zynq UltraScale + MPSoC PS I/O Name	I/O	Description
enet1_mdio_mdc	O	Management data clock to pin
enet1_mdio_i	I	Management data input from MDIO pin
enet1_mdio_o	O	Management data output to MDIO pin
enet1_mdio_t	O	3-state enable to MDIO pin, active-Low. At the top-level the three MDIO pins are all used to drive a single 3-state pin.

Table B-20: MDIO_ENET2

Zynq UltraScale + MPSoC PS I/O Name	I/O	Description
enet2_mdio_mdc	O	Management data clock to pin
enet2_mdio_i	I	Management data input from MDIO pin

Table B-20: MDIO_ENET2 (Cont'd)

Zynq UltraScale + MPSoC PS I/O Name	I/O	Description
enet2_mdio_o	O	Management data output to MDIO pin
enet2_mdio_t	O	3-state enable to MDIO pin, active-Low. At the top-level the three MDIO pins are all used to drive a single 3-state pin.

Table B-21: MDIO_ENET3

Zynq UltraScale + MPSoC PS I/O Name	I/O	Description
enet3_mdio_mdc	O	Management data clock to pin
enet3_mdio_i	I	Management data input from MDIO pin
enet3_mdio_o	O	Management data output to MDIO pin
enet3_mdio_t	O	3-state enable to MDIO pin, active-Low. At the top-level the three MDIO pins are all used to drive a single 3-state pin.

Table B-22: PL_CLK0

Zynq UltraScale + MPSoC PS I/O Name	I/O	Description
pl_clk0	O	PL Clock 0

Table B-23: PL_CLK1

Zynq UltraScale + MPSoC PS I/O Name	I/O	Description
pl_clk1	O	PL Clock 1

Table B-24: PL_CLK2

Zynq UltraScale + MPSoC PS I/O Name	I/O	Description
pl_clk2	O	PL Clock 2

Table B-25: PL_CLK3

Zynq UltraScale + MPSoC PS I/O Name	I/O	Description
pl_clk3	O	PL Clock 3

Table B-26: PL_PS_IRQ0

Zynq UltraScale + MPSoC PS I/O Name	I/O	Description
pl_ps_irq0	I	pl to ps interrupt 0

Table B-27: PL_PS_IRQ1

Zynq UltraScale + MPSoC PS I/O Name	I/O	Description
pl_ps_irq1	I	pl to ps interrupt 1

Table B-28: SDIO0

Zynq UltraScale + MPSoC PS I/O Name	I/O	Description
sdio0_clkout	O	Clock output to SD/SDIO0 slave device
sdio0_fb_clk_in	I	Clock feedback from sd0_clk_out from pad
sdio0_cmdout	O	Command indicator output
sdio0_cmdin	I	Command indicator input
sdio0_cmdena	O	Command indicator enable
sdio0_datain	I	7-bit input data bus. Can also be used in SPI flash memory, serial or 2-bit modes.
sdio0_dataout	O	7-bit output data bus. Can also be used in SPI flash memory, serial or 2-bit modes.
sdio0_dataena	O	Enable control for data bus
sdio0_cd_n	I	Card detection for single slot
sdio0_wp	I	Secure digital non-volatile memory card (SD card) write protect, active-Low
sdio0_ledcontrol	O	LED ON. Cautions you not to remove the card while the SD card is being accessed.
sdio0_buspower	O	Control SD card power supply
sdio0_bus_volt	O	SD bus volt select

Table B-29: SDIO1

Zynq UltraScale + MPSoC PS I/O Name	I/O	Description
sdio1_clkout	O	Clock output to SD/SDIO1 slave device
sdio1_fb_clk_in	I	Clock feedback from sd1_clk_out from pad
sdio1_cmdout	O	Command indicator output
sdio1_cmdin	I	Command indicator input

Table B-29: SDIO1 (Cont'd)

Zynq UltraScale + MPSoC PS I/O Name	I/O	Description
sdio1_cmdena	O	Command indicator enable
sdio1_datain	I	7-bit input data bus. Can also be used in SPI flash memory, serial or 2-bit modes.
sdio1_dataout	O	7-bit output data bus. Can also be used in SPI flash memory, serial or 2-bit modes.
sdio1_dataena	O	Enable control for data bus
sdio1_cd_n	I	Card detection for single slot
sdio1_wp	I	SD card write protect, active-Low
sdio1_ledcontrol	O	LED ON: Cautions you not to remove the card while the SD card is being accessed.
sdio1_bus_power	O	Control SD card power supply
sdio1_bus_volt	O	SD bus volt select

Table B-30: SPI0

Zynq UltraScale + MPSoC PS I/O Name	I/O	Description
spi0_sclk_i	I	SPI flash memory slave clock
spi0_sclk_o	O	SPI flash memory master clock output
spi0_sclk_t	O	SPI flash memory clock 3-state enable, active-Low. This signal is a version of spi0_n_sclk_en.
spi0_m_i	I	SPI flash memory master in slave out (MISO) signal, master input
spi0_m_o	O	SPI flash memory master out slave in (MOSI) signal, master output
spi0_mo_t	O	SPI flash memory MOSI signal, 3-state enable, active-Low. This signal is a version of spi0_n_mo_en.
spi0_s_i	I	SPI flash memory MOSI signal, slave input
spi0_s_o	O	SPI flash memory MISO signal, slave output
spi0_n_ss_o_n	O	SPI flash memory slave select outputs
spi0_ss_n_t	O	SPI flash memory slave select 3-state enable, active-Low. This signal is a version of spi0_n_ss_en.

Table B-31: SPI1

Zynq UltraScale + MPSoC PS I/O Name	I/O	Description
spi1_sclk_i	I	SPI flash memory slave clock. Can be passed directly from pin if low speed (< 50 MHz).
spi1_sclk_o	O	SPI flash memory master clock output. Can be passed directly to pin if low speed (< 50 MHz).
spi1_sclk_t	O	SPI flash memory clock 3-state enable, active-Low. This signal is a version of spi1_n_sclk_en
spi1_m_i	I	SPI flash memory MISO signal, master input
spi1_m_o	O	SPI flash memory MOSI signal, master output
spi1_mo_t	O	SPI flash memory MOSI signal, 3-state enable, active-Low. This signal is a version of spi1_n_mo_en.
spi1_s_i	I	SPI flash memory MOSI signal, slave input
spi1_s_o	O	SPI flash memory MISO signal, slave output
spi1_n_ss_o_n	O	SPI flash memory peripheral select outputs
spi1_ss_n_t	O	SPI flash memory slave select 3-state enable, active-Low. This signal is a version of spi1_n_ss_en.

Table B-32: Trace0

Zynq UltraScale + MPSoC PS I/O Name	I/O	Description
tracectl	O	Trace control
tracedata	O	Trace data

Table B-33: UART0

Zynq UltraScale + MPSoC PS I/O Name	I/O	Description
uart0_ctsn	I	Clear-to-send flow control
uart0_rtsn	O	Request-to-send flow control
uart0_dsrn	I	Modem data set ready
uart0_dcdn	I	Modem data carrier detect
uart0_rin	I	Modem ring indicator
uart0_dtrn	O	Modem data terminal ready

Table B-34: UART1

Zynq UltraScale + MPSoC PS I/O Name	I/O	Description
uart1_ctsn	I	Clear-to-send flow control
uart1_rtsn	O	Request-to-send flow control
uart1_dsrn	I	Modem data set ready
uart1_dcdn	I	Modem data carrier detect
uart1_rin	I	Modem ring indicator
uart1_dtrn	O	Modem data terminal ready

Table B-35: TTC0

Zynq UltraScale + MPSoC PS I/O Name	I/O	Description
ttc0_wave_o	O	Triple timer counter (TTC) clock (Waveform generated)
ttc0_clk_i	I	TTC0 clock input

Table B-36: TTC1

Zynq UltraScale + MPSoC PS I/O Name	I/O	Description
ttc1_wave_o	O	TTC clock (Waveform generated)
ttc1_clk_i	I	TTC1 clock input

Table B-37: TTC2

Zynq UltraScale + MPSoC PS I/O Name	I/O	Description
ttc3_wave_o	O	TTC clock (Waveform generated)
ttc2_clk_i	I	TTC2 clock input

Table B-38: TTC3

Zynq UltraScale + MPSoC PS I/O Name	I/O	Description
ttc3_wave_o	O	TTC clock (Waveform generated)
ttc3_clk_i	I	TTC3 clock input

Table B-39: WDT0

Zynq UltraScale + MPSoC PS I/O Name	I/O	Description
wdt0_clk_i	I	WDT0 clock input
wdt0_rst_o	O	WDT0 reset

Table B-40: WDT1

Zynq UltraScale + MPSoC PS I/O Name	I/O	Description
wdt1_clk_i	I	WDT1 clock input
wdt1_rst_o	O	WDT1 reset

Table B-41: Interrupt Signals

Zynq UltraScale + MPSoC PS I/O Name	I/O	Description
ps_pl_irq_can0	O	CAN0 interrupt
ps_pl_irq_can1	O	CAN1 interrupt
ps_pl_irq_enet0	O	Ethernet0 interrupt
ps_pl_irq_enet1	O	Gigabit ethernet1 interrupt
ps_pl_irq_enet2	O	Gigabit ethernet2 interrupt
ps_pl_irq_enet3	O	Gigabit ethernet3 interrupt
ps_pl_irq_enet0_wake0	O	Ethernet0 wake-up interrupt
ps_pl_irq_enet0_wake1	O	Gigabit ethernet1 wake-up interrupt
ps_pl_irq_enet0_wake2	O	Gigabit ethernet2 wake-up interrupt
ps_pl_irq_enet0_wake3	O	Gigabit ethernet3 wake-up interrupt
ps_pl_irq_gpio	O	GPIO interrupt
ps_pl_irq_i2c0	O	I2C0 interrupt
ps_pl_irq_i2c1	O	I2C1 interrupt
ps_pl_irq_uart0	O	UART0 interrupt
ps_pl_irq_uart1	O	UART1 interrupt
ps_pl_irq_sdio0	O	SDIO0 interrupt
ps_pl_irq_sdio1	O	SDIO1 interrupt
ps_pl_irq_sdio0_wake	O	SDIO0 wake interrupt
ps_pl_irq_sdio1_wake	O	SDIO1 wake interrupt
ps_pl_irq_spi0	O	SPI0 interrupt
ps_pl_irq_spi1	O	SPI1 interrupt

Table B-41: Interrupt Signals (Cont'd)

Zynq UltraScale + MPSoC PS I/O Name	I/O	Description
ps_pl_irq_qspi	O	SPI flash memory interrupt
ps_pl_irq_ttc0_0	O	Triple Timer 0 Counter 0 Interrupt
ps_pl_irq_ttc0_1	O	Triple Timer 0 Counter 1 Interrupt
ps_pl_irq_ttc0_2	O	Triple Timer 0 Counter 2 Interrupt
ps_pl_irq_ttc1_0	O	Triple Timer 1 Counter 0 Interrupt
ps_pl_irq_ttc1_1	O	Triple Timer 1 Counter 1 Interrupt
ps_pl_irq_ttc1_2	O	Triple Timer 1 Counter 2 Interrupt
ps_pl_irq_ttc2_0	O	Triple Timer 2 Counter 0 Interrupt

Table B-42: M_AXI_HPM0_FPD

Zynq UltraScale + MPSoC PS I/O Name	I/O	Description
maxigp0_awid	O	Write address ID. This signal is the identification tag for the write address group of signals.
maxigp0_awaddr	O	Write address. The write address bus gives the address of the first transfer in a write burst transaction. The associated control signals are used to determine the addresses of the remaining transfers in the burst.
maxigp0_awlen	O	Burst length. The burst length gives the exact number of transfers in a burst. This information determines the number of data transfers associated with the address.
maxigp0_awsiz	O	Burst size. This signal indicates the size of each transfer in the burst. Byte lane strobes indicate exactly which byte lanes to update.
maxigp0_awburst	O	Burst type. The burst type, coupled with the size information, details how the address for each transfer within the burst is calculated.
maxigp0_awlock	O	Lock type. This signal provides additional information about the atomic characteristics of the transfer.
maxigp0_awcache	O	Cache type. This signal indicates the bufferable, cacheable, write-through, write-back, and allocate attributes of the transaction.
maxigp0_awprot	O	Protection type. This signal indicates the normal, privileged, or secure protection level of the transaction and whether the transaction is a data access or an instruction access.
maxigp0_awvalid	O	Write address valid. This signal indicates that valid write address and control information are available. 1 = address and control information available 0 = address and control information not available The address and control information remain stable until the address acknowledge signal, AWREADY, goes High.

Table B-42: M_AXI_HPM0_FPD (Cont'd)

Zynq UltraScale + MPSoC PS I/O Name	I/O	Description
maxigp0_awuser	O	User-defined address write (AW) channel signals
maxigp0_awready	I	Write address ready. This signal indicates that the slave is ready to accept an address and associated control signals. 1 = slave ready 0 = slave not ready
maxigp0_wdata	O	Write data. The write data bus can be 8, 16, 32, 64, 128, 256, 512, or 1,024 bits wide.
maxigp0_wstrb	O	Write strobes. This signal indicates which byte lanes to update in memory. There is one write strobe for each eight bits of the write data bus.
maxigp0_wlast	O	Write last. This signal indicates the last transfer in a write burst.
maxigp0_wvalid	O	Write valid. This signal indicates that valid write data and strobes are available. 1 = write data and strobes available 0 = write data and strobes not available
maxigp0_wready	I	Write ready. This signal indicates that the slave can accept the write data. 1 = slave ready 0 = slave not ready
maxigp0_bid	I	Response ID. The identification tag of the write response
maxigp0_bresp	I	Write response. This signal indicates the status of the write transaction. The allowable responses are OKAY, EXOKAY, SLVERR, and DECERR.
maxigp0_bvalid	I	Write response valid. This signal indicates that a valid write response is available. 1 = write response available 0 = write response not available
maxigp0_bready	O	Response ready. This signal indicates that the master can accept the response information. 1 = master ready 0 = master not ready
maxigp0_arid	O	Read address ID. This signal is the identification tag for the read address group of signals.
maxigp0_araddr	O	Read address. The read address bus gives the initial address of a read burst transaction.
maxigp0_arlen	O	Burst length. The burst length gives the exact number of transfers in a burst. This information determines the number of data transfers associated with the address.
maxigp0_arsize	O	Burst size. This signal indicates the size of each transfer in the burst

Table B-42: M_AXI_HPM0_FPD (Cont'd)

Zynq UltraScale + MPSoC PS I/O Name	I/O	Description
maxigp0_arburst	O	Burst type. The burst type, coupled with the size information, details how the address for each transfer within the burst is calculated.
maxigp0_arlock	O	Lock type. This signal provides additional information about the atomic characteristics of the transfer.
maxigp0_arcache	O	Cache type. This signal provides additional information about the cacheable characteristics of the transfer
maxigp0_arprot	O	Protection type. This signal provides protection unit information for the transaction.
maxigp0_arvalid	O	Read address valid. This signal indicates, when High, that the read address and control information is valid and remains stable until the address acknowledge signal, ARREADY, is High.
maxigp0_aruser	O	User-defined address read (AR) channel signals
maxigp0_arready	I	Read address ready. This signal indicates that the slave is ready to accept an address and associated control signals. 1 = slave ready 0 = slave not ready
maxigp0_rid	I	Read ID tag. This signal is the ID tag of the read data group of signals.
maxigp0_rdata	I	Read data. The read data bus can be 8, 16, 32, 64, 128, 256, 512, or 1,024 bits wide.
maxigp0_rresp	I	Read response. This signal indicates the status of the read transfer. The allowable responses are OKAY, EXOKAY, SLVERR, and DECERR.
maxigp0_rlast	I	Read last. This signal indicates the last transfer in a read burst.
maxigp0_rvalid	I	Read valid. This signal indicates that the required read data is available and the read transfer can complete.
maxigp0_rready	O	Read ready. This signal indicates that the master can accept the read data and response information. 1= master ready 0 = master not ready
maxigp0_awqos	O	Wr addr channel quality of service (QOS) input
maxigp0_arqos	O	Rd addr channel QOS input

Table B-43: M_AXI_HPM0_FPD_ACLK

Zynq UltraScale + MPSoC PS I/O Name	I/O	Description
maxigp0_awid	O	Write address ID. This signal is the identification tag for the write address group of signals.
maxihpm0_fpd_aclk	I	Input clock signal

Table B-44: M_AXI_HPM0_LPD

Zynq UltraScale + MPSoC PS I/O Name	I/O	Description
maxigp2_awid	O	Write address ID. This signal is the identification tag for the write address group of signals.
maxigp2_awaddr	O	Write address. The write address bus gives the address of the first transfer in a write burst transaction. The associated control signals are used to determine the addresses of the remaining transfers in the burst.
maxigp2_awlen	O	Burst length. The burst length gives the exact number of transfers in a burst. This information determines the number of data transfers associated with the address.
maxigp2_awsiz	O	Burst size. This signal indicates the size of each transfer in the burst. Byte lane strobes indicate exactly which byte lanes to update.
maxigp2_awburst	O	Burst type. The burst type, coupled with the size information, details how the address for each transfer within the burst is calculated.
maxigp2_awlock	O	Lock type. This signal provides additional information about the atomic characteristics of the transfer.
maxigp2_awcache	O	Cache type. This signal indicates the buffer able, cacheable, write-through, write-back, and allocate attributes of the transaction.
maxigp2_awprot	O	Protection type. This signal indicates the normal, privileged, or secure protection level of the transaction and whether the transaction is a data access or an instruction access.
maxigp2_awvalid	O	Write address valid. This signal indicates that valid write address and control information are available. 1 = address and control information available 0 = address and control information not available The address and control information remain stable until the address acknowledge signal, AWREADY, goes High.
maxigp2_awuser	O	User-defined address write (AW) channel signals
maxigp2_awready	I	Write address ready. This signal indicates that the slave is ready to accept an address and associated control signals. 1 = slave ready 0 = slave not ready
maxigp2_wdata	O	Write data. The write data bus can be 8, 16, 32, 64, 128, 256, 512, or 1,024 bits wide.
maxigp2_wstrb	O	Write strobes. This signal indicates which byte lanes to update in memory. There is one write strobe for each 8 bits of the write data bus.
maxigp2_wlast	O	Write last. This signal indicates the last transfer in a write burst.

Table B-44: M_AXI_HPM0_LPD (Cont'd)

Zynq UltraScale + MPSoC PS I/O Name	I/O	Description
maxigp2_wvalid	O	Write valid. This signal indicates that valid write data and strobes are available. 1 = write data and strobes available 0 = write data and strobes not available
maxigp2_wready	I	Write ready. This signal indicates that the slave can accept the write data. 1 = slave ready 0 = slave not ready
maxigp2_bid	I	Response ID. The identification tag of the write response
maxigp2_bresp	I	Write response. This signal indicates the status of the write transaction. The allowable responses are OKAY, EXOKAY, SLVERR, and DECERR.
maxigp2_bvalid	I	Write response valid. This signal indicates that a valid write response is available. 1 = write response available 0 = write response not available
maxigp2_bready	O	Response ready. This signal indicates that the master can accept the response information. 1 = master ready 0 = master not ready
maxigp2_arid	O	Read address ID. This signal is the identification tag for the read address group of signals.
maxigp2_araddr	O	Read address. The read address bus gives the initial address of a read burst transaction.
maxigp2_arlen	O	Burst length. The burst length gives the exact number of transfers in a burst. This information determines the number of data transfers associated with the address.
maxigp2_arsize	O	Burst size. This signal indicates the size of each transfer in the burst.
maxigp2_arburst	O	Burst type. The burst type, coupled with the size information, details how the address for each transfer within the burst is calculated.
maxigp2_arlock	O	Lock type. This signal provides additional information about the atomic characteristics of the transfer.
maxigp2_arcache	O	Cache type. This signal provides additional information about the cacheable characteristics of the transfer.
maxigp2_arprot	O	Protection type. This signal provides protection unit information for the transaction.

Table B-44: M_AXI_HPM0_LPD (Cont'd)

Zynq UltraScale + MPSoC PS I/O Name	I/O	Description
maxigp2_arvalid	O	Read address valid. This signal indicates, when High, that the read address and control information is valid and remains stable until the address acknowledge signal, ARREADY, is High.
maxigp2_aruser	O	User-defined AR channel signals
maxigp2_arready	I	Read address ready. This signal indicates that the slave is ready to accept an address and associated control signals. 1 = slave ready 0 = slave not ready
maxigp2_rid	I	Read ID tag. This signal is the ID tag of the read data group of signals.
maxigp2_rdata	I	Read data. The read data bus can be 8, 16, 32, 64, 128, 256, 512, or 1,024 bits wide.
maxigp2_rresp	I	Read response. This signal indicates the status of the read transfer. The allowable responses are OKAY, EXOKAY, SLVERR, and DECERR
maxigp2_rlast	I	Read last. This signal indicates the last transfer in a read burst.
maxigp2_rvalid	I	Read valid. This signal indicates that the required read data is available and the read transfer can complete.
maxigp2_rready	O	Read ready. This signal indicates that the master can accept the read data and response information. 1= master ready 0= master not ready
maxigp2_awqos	O	Wr addr channel QOS input
maxigp2_arqos	O	Rd addr channel QOS input

Table B-45: M_AXI_HPM0_LPD_ACLK

Zynq UltraScale + MPSoC PS I/O Name	I/O	Description
maxigp2_awid	O	Write address ID. This signal is the identification tag for the write address group of signals.
maxihpm0_lpd_aclk	I	Input clock signal

Table B-46: M_AXI_HPM1_FPD

Zynq UltraScale + MPSoC PS I/O Name	I/O	Description
maxigp1_awid	O	Write address ID. This signal is the identification tag for the write address group of signals.
maxigp1_awaddr	O	Write address. The write address bus gives the address of the first transfer in a write burst transaction. The associated control signals are used to determine the addresses of the remaining transfers in the burst.
maxigp1_awlen	O	Burst length. The burst length gives the exact number of transfers in a burst. This information determines the number of data transfers associated with the address.
maxigp1_awsiz	O	Burst size. This signal indicates the size of each transfer in the burst. Byte lane strobes indicate exactly which byte lanes to update.
maxigp1_awburst	O	Burst type. The burst type, coupled with the size information, details how the address for each transfer within the burst is calculated.
maxigp1_awlock	O	Lock type. This signal provides additional information about the atomic characteristics of the transfer.
maxigp1_awcache	O	Cache type. This signal indicates the buffer able, cacheable, write-through, write-back, and allocate attributes of the transaction.
maxigp1_awprot	O	Protection type. This signal indicates the normal, privileged, or secure protection level of the transaction and whether the transaction is a data access or an instruction access.
maxigp1_awvalid	O	Write address valid. This signal indicates that valid write address and control information are available. 1 = address and control information available 0 = address and control information not available The address and control information remain stable until the address acknowledge signal, AWREADY, goes High.
maxigp1_awuser	O	User-defined AW channel signals
maxigp1_awready	I	Write address ready. This signal indicates that the slave is ready to accept an address and associated control signals. 1 = slave ready 0 = slave not ready
maxigp1_wdata	O	Write data. The write data bus can be 8, 16, 32, 64, 128, 256, 512, or 1,024 bits wide.
maxigp1_wstrb	O	Write strobes. This signal indicates which byte lanes to update in memory. There is one write strobe for each eight bits of the write data bus.
maxigp1_wlast	O	Write last. This signal indicates the last transfer in a write burst.

Table B-46: M_AXI_HPM1_FPD (Cont'd)

Zynq UltraScale + MPSoC PS I/O Name	I/O	Description
maxigp1_wvalid	O	Write valid. This signal indicates that valid write data and strobes are available. 1 = write data and strobes available 0 = write data and strobes not available
maxigp1_wready	I	Write ready. This signal indicates that the slave can accept the write data. 1 = slave ready 0 = slave not ready
maxigp1_bid	I	Response ID. The identification tag of the write response
maxigp1_bresp	I	Write response. This signal indicates the status of the write transaction. The allowable responses are OKAY, EXOKAY, SLVERR, and DECERR.
maxigp1_bvalid	I	Write response valid. This signal indicates that a valid write response is available. 1 = write response available 0 = write response not available
maxigp1_bready	O	Response ready. This signal indicates that the master can accept the response information. 1 = master ready 0 = master not ready
maxigp1_arid	O	Read address ID. This signal is the identification tag for the read address group of signals.
maxigp1_araddr	O	Read address. The read address bus gives the initial address of a read burst transaction.
maxigp1_arlen	O	Burst length. The burst length gives the exact number of transfers in a burst. This information determines the number of data transfers associated with the address.
maxigp1_arsize	O	Burst size. This signal indicates the size of each transfer in the burst.
maxigp1_arburst	O	Burst type. The burst type, coupled with the size information, details how the address for each transfer within the burst is calculated.
maxigp1_arlock	O	Lock type. This signal provides additional information about the atomic characteristics of the transfer.
maxigp1_arcache	O	Cache type. This signal provides additional information about the cacheable characteristics of the transfer.
maxigp1_arprot	O	Protection type. This signal provides protection unit information for the transaction.

Table B-46: M_AXI_HPM1_FPD (Cont'd)

Zynq UltraScale + MPSoC PS I/O Name	I/O	Description
maxigp1_arvalid	O	Read address valid. This signal indicates, when High, that the read address and control information is valid and remains stable until the address acknowledge signal, ARREADY, is High.
maxigp1_aruser	O	User-defined AR channel signals
maxigp1_arready	I	Read address ready. This signal indicates that the slave is ready to accept an address and associated control signals. 1 = slave ready 0 = slave not ready
maxigp1_rid	I	Read ID tag. This signal is the ID tag of the read data group of signals.
maxigp1_rdata	I	Read data. The read data bus can be 8, 16, 32, 64, 128, 256, 512, or 1,024 bits wide.
maxigp1_rresp	I	Read response. This signal indicates the status of the read transfer. The allowable responses are OKAY, EXOKAY, SLVERR, and DECERR.
maxigp1_rlast	I	Read last. This signal indicates the last transfer in a read burst.
maxigp1_rvalid	I	Read valid. This signal indicates that the required read data is available and the read transfer can complete.
maxigp1_rready	O	Read ready. This signal indicates that the master can accept the read data and response information. 1= master ready 0 = master not ready
maxigp1_awqos	O	Wr addr channel QOS input
maxigp1_arqos	O	Rd addr channel QOS input

Table B-47: M_AXI_HPM1_FPD_ACLK

Zynq UltraScale + MPSoC PS I/O Name	I/O	Description
maxigp1_awid	O	Write address ID. This signal is the identification tag for the write address group of signals.
maxihpm1_fpd_aclk	I	Input clock signal

Table B-48: S_AXI_ACE_FPD

Zynq UltraScale + MPSoC PS I/O Name	I/O	Description
sacefpd_wuser	I	User signal. Optional user-defined signal in the write data channel.
sacefpd_buser	O	User signal. Optional user-defined signal in the write response channel.
sacefpd_ruser	O	User signal. Optional user-defined signal in the read data channel.
sacefpd_awuser	I	User signal. Optional user-defined signal in the write address channel.
sacefpd_awsnoop	I	This signal indicates the transaction type for shareable write transactions.
sacefpd_awsize	I	Burst size. This signal indicates the size of each transfer in the burst. Byte lane strobes indicate exactly which byte lanes to update.
sacefpd_awregion	I	Region identifier. Permits a single physical interface on a slave to be used for multiple logical interfaces.
sacefpd_awqos	I	Quality of service. Identifier sent for each write transaction.
sacefpd_awprot	I	Protection type. This signal indicates the normal, privileged, or secure protection level of the transaction and whether the transaction is a data access or an instruction access.
sacefpd_awlen	I	Burst length. The burst length gives the exact number of transfers in a burst. This information determines the number of data transfers associated with the address.
sacefpd_awid	I	Write address ID. This signal is the identification tag for the write address group of signals.
sacefpd_awdomain	I	The signal indicates the shareability domain of a write transaction.
sacefpd_awcache	I	Cache type. This signal indicates the buffer able, cacheable, write-through, write-back, and allocate attributes of the transaction.
sacefpd_awburst	I	Burst type. The burst type, coupled with the size information, details how the address for each transfer within the burst is calculated.
sacefpd_awbar	I	This signal indicates a write barrier transaction.
sacefpd_awaddr	I	Write address. The write address bus gives the address of the first transfer in a write burst transaction. The associated control signals are used to determine the addresses of the remaining transfers in the burst.
sacefpd_awlock	I	Lock type. This signal provides additional information about the atomic characteristics of the transfer.

Table B-48: S_AXI_ACE_FPD (Cont'd)

Zynq UltraScale + MPSoC PS I/O Name	I/O	Description
sacefpd_awvalid	I	Write address valid. This signal indicates that valid write address and control information are available. 1 = address and control information available 0 = address and control information not available The address and control information remain stable until the address acknowledge signal, AWREADY, goes High.
sacefpd_awready	O	Write address channel ready signal
sacefpd_wstrb	I	Write strobes. This signal indicates which byte lanes to update in memory. There is one write strobe for each eight bits of the write data bus.
sacefpd_wdata	I	Write data. The write data bus can be 8, 16, 32, 64, 128, 256, 512, or 1,024 bits wide.
sacefpd_wlast	I	Write last. This signal indicates the last transfer in a write burst.
sacefpd_wvalid	I	Write valid. This signal indicates that valid write data and strobes are available. 1 = write data and strobes available 0 = write data and strobes not available
sacefpd_wready	O	Write ready. This signal indicates that the slave can accept the write data. 1 = slave ready 0 = slave not ready
sacefpd_bresp	O	Write response. This signal indicates the status of the write transaction. The allowable responses are OKAY, EXOKAY, SLVERR, and DECERR.
sacefpd_bid	O	Response ID. The identification tag of the write response
sacefpd_bvalid	O	Write response valid. This signal indicates that a valid write response is available. 1 = write response available 0 = write response not available
sacefpd_bready	I	Response ready. This signal indicates that the master can accept the response information. 1 = master ready 0 = master not ready
sacefpd_aruser	I	User signal. Optional User-defined signal in the read address channel.
sacefpd_arsnoop	I	This signal indicates the transaction type for shareable read transactions.
sacefpd_arsize	I	Burst size. This signal indicates the size of each transfer in the burst.

Table B-48: S_AXI_ACE_FPD (Cont'd)

Zynq UltraScale + MPSoC PS I/O Name	I/O	Description
sacefpd_arregion	I	Region Identifier. Permits a single physical interface on a slave to be used for multiple logical interfaces.
sacefpd_arqos	I	Quality of service, identifier sent for each read transaction.
sacefpd_arprot	I	Protection type. This signal provides protection unit information for the transaction.
sacefpd_arlen	I	Burst length. The burst length gives the exact number of transfers in a burst. This information determines the number of data transfers associated with the address.
sacefpd_arid	I	Read address ID. This signal is the identification tag for the read address group of signals.
sacefpd_ardomain	I	This signal indicates the shareability domain of a read transaction.
sacefpd_arcache	I	Cache type. This signal provides additional information about the cacheable characteristics of the transfer.
sacefpd_arburst	I	Burst type. The burst type, coupled with the size information, details how the address for each transfer within the burst is calculated.
sacefpd_arbar	I	This signal indicates a read barrier transaction.
sacefpd_araddr	I	Read address. The read address bus gives the initial address of a read burst transaction.
sacefpd_arlock	I	Lock type. This signal provides additional information about the atomic characteristics of the transfer.
sacefpd_arvalid	I	Read address valid. This signal indicates, when High, that the read address and control information is valid and remains stable until the address acknowledge signal, ARREADY, is High.
sacefpd_arready	O	Read address ready. This signal indicates that the slave is ready to accept an address and associated control signals. 1 = slave ready 0 = slave not ready
sacefpd_rresp	O	Read response. This signal indicates the status of the read transfer. The allowable responses are OKAY, EXOKAY, SLVERR, and DECERR.
sacefpd_rid	O	Read ID tag. This signal is the ID tag of the read data group of signals.
sacefpd_rdata	O	Read data. The read data bus can be 8, 16, 32, 64, 128, 256, 512, or 1,024 bits wide.
sacefpd_rlast	O	Read last. This signal indicates the last transfer in a read burst.
sacefpd_rvalid	O	Read valid. This signal indicates that the required read data is available and the read transfer can complete.

Table B-48: S_AXI_ACE_FPD (Cont'd)

Zynq UltraScale + MPSoC PS I/O Name	I/O	Description
sacefpd_rready	I	Read ready. This signal indicates that the master can accept the read data and response information. 1 = master ready 0 = master not ready
sacefpd_acsnoop	O	Snoop transaction type. This signal indicates the transaction type of the snoop transaction.
sacefpd_acprot	O	Snoop protection type. This signal indicates the security level of the snoop transaction.
sacefpd_acaddr	O	Snoop Address. This signal indicates the address of a snoop transaction. The snoop address width must match the width of the read and write address buses.
sacefpd_acvalid	O	Snoop address valid. This signal indicates that the snoop address and control information is valid.
sacefpd_acready	I	Snoop address ready. This signal indicates that the snoop address and control information can be accepted in the current cycle.
sacefpd_cddata	I	Snoop data. Transfer data from a snooped master.
sacefpd_cdlast	I	This signal indicates the last data transfer of a snoop transaction.
sacefpd_cdvalid	I	Snoop data valid. This signal indicates that the snoop is valid.
sacefpd_cdready	O	Snoop data ready. This signal indicates that the snoop data can be accepted in the current cycle.
sacefpd_crresp	I	Snoop response. This signal indicates the response to a snoop transaction and how it completes.
sacefpd_crvalid	I	Snoop response valid. This signal indicates that the snoop response is valid.
sacefpd_crready	O	Snoop response ready. This signal indicates the snoop response can be accepted in the current cycle.
sacefpd_wack	I	Write acknowledge. This signal indicates that a master has completed a write transaction.
sacefpd_rack	I	Read acknowledge. This signal indicates that a master has completed a read transaction.

Table B-49: S_AXI_ACP_FPD

Zynq UltraScale + MPSoc PS I/O Name	I/O	Description
saxiacp_awuser	I	User signal. Optional user-defined signal in the write address channel.
saxiacp_buser	O	User signal. Optional user-defined signal in the write response channel.
saxiacp_wuser	I	User signal. Optional user-defined signal in the write data channel.
saxiacp_awid	I	Write address ID. This signal is the identification tag for the write address group of signals.
saxiacp_awaddr	I	Write address. The write address bus gives the address of the first transfer in a write burst transaction. The associated control signals are used to determine the addresses of the remaining transfers in the burst.
saxiacp_awlen	I	Burst length. The burst length gives the exact number of transfers in a burst. This information determines the number of data transfers associated with the address.
saxiacp_awsz	I	Burst size. This signal indicates the size of each transfer in the burst. Byte lane strobes indicate exactly which byte lanes to update.
saxiacp_awburst	I	Burst type. The burst type, coupled with the size information, details how the address for each transfer within the burst is calculated.
saxiacp_awlock	I	Lock type. This signal provides additional information about the atomic characteristics of the transfer.
saxiacp_awcache	I	Cache type. This signal indicates the buffer able, cacheable, write-through, write-back, and allocate attributes of the transaction.
saxiacp_awprot	I	Protection type. This signal indicates the normal, privileged, or secure protection level of the transaction and whether the transaction is a data access or an instruction access.
saxiacp_awvalid	I	Write address valid. This signal indicates that valid write address and control information are available. 1 = address and control information available 0 = address and control information not available The address and control information remain stable until the address acknowledge signal, AWREADY, goes High.
saxiacp_awready	I	Write address channel ready signal
saxiacp_wdata	I	Write data. The write data bus can be 8, 16, 32, 64, 128, 256, 512, or 1,024 bits wide.
saxiacp_wstrb	I	Write strobes. This signal indicates which byte lanes to update in memory. There is one write strobe for each eight bits of the write data bus.

Table B-49: S_AXI_ACP_FPD (Cont'd)

Zynq UltraScale + MPSoC PS I/O Name	I/O	Description
saxiacp_wlast	I	Write last. This signal indicates the last transfer in a write burst.
saxiacp_wvalid	O	Write valid. This signal indicates that valid write data and strobes are available. 1 = write data and strobes available 0 = write data and strobes not available
saxiacp_wready	O	Write ready. This signal indicates that the slave can accept the write data. 1 = slave ready 0 = slave not ready
saxiacp_bid	O	Response ID. The identification tag of the write response
saxiacp_bresp	O	Write response. This signal indicates the status of the write transaction. The allowable responses are OKAY, EXOKAY, SLVERR, and DECERR.
saxiacp_bvalid	I	Write response valid. This signal indicates that a valid write response is available. 1 = write response available 0 = write response not available
saxiacp_bready	I	Response ready. This signal indicates that the master can accept the response information. 1 = master ready 0 = master not ready
saxiacp_arid	I	Read address ID. This signal is the identification tag for the read address group of signals.
saxiacp_araddr	I	Read address. The read address bus gives the initial address of a read burst transaction.
saxiacp_arlen	I	Burst length. The burst length gives the exact number of transfers in a burst. This information determines the number of data transfers associated with the address.
saxiacp_arsize	I	Burst size. This signal indicates the size of each transfer in the burst.
saxiacp_arburst	I	Burst type. The burst type and the size information determine how the address for each transfer within the burst is calculated.
saxiacp_arlock	I	Lock type. This signal provides additional information about the atomic characteristics of the transfer.
saxiacp_arcache	I	Cache type. This signal provides additional information about the cacheable characteristics of the transfer.
saxiacp_arprot	I	Protection type. This signal indicates the privilege and security level of the transaction, and whether the transaction is a data access or an instruction access.

Table B-49: S_AXI_ACP_FPD (Cont'd)

Zynq UltraScale + MPSoC PS I/O Name	I/O	Description
saxiacp_arvalid	O	Read address valid. This signal indicates, when High, that the read address and control information is valid and remains stable until the address acknowledge signal, ARREADY, is High
saxiacp_arready	O	Read address ready. This signal indicates that the slave is ready to accept an address and associated control signals. 1 = slave ready 0 = slave not ready
saxiacp_rid	O	Read ID tag. This signal is the ID tag of the read data group of signals.
saxiacp_rdata	O	Read data. The read data bus can be 8, 16, 32, 64, 128, 256, 512, or 1,024 bits wide.
saxiacp_rresp	O	Read response. This signal indicates the status of the read transfer. The allowable responses are OKAY, EXOKAY, SLVERR, and DECERR.
saxiacp_rl原因	I	Read last. This signal indicates the last transfer in a read burst.
saxiacp_rvalid	O	Read valid. This signal indicates that the required read data is available and the read transfer can complete.
saxiacp_rready	O	Read ready. This signal indicates that the master can accept the read data and response information. 1 = master ready 0 = master not ready
saxiacp_awqos	O	Wr addr channel QOS input.
saxiacp_arqos	O	Rd addr channel QOS input. Quality of service, sent for each read transaction.

Table B-50: S_AXI_ACP_FPD_ACLK

Zynq UltraScale + MPSoC PS I/O Name	I/O	Description
saxiacp_awuser	I	User signal. Optional user-defined signal in the write address channel
saxiacp_fpd_aclk	I	Input clock signal

Table B-51: S_AXI_HPO_FPD

Zynq UltraScale + MPSoC PS I/O Name	I/O	Description
saxigp2_aruser	I	User-defined AR channel signals
saxigp2_awuser	I	User-defined AW channel signals
saxigp2_awid	I	Write address ID. This signal is the identification tag for the write address group of signals.
saxigp2_awaddr	I	Write address. The write address bus gives the address of the first transfer in a write burst transaction. The associated control signals are used to determine the addresses of the remaining transfers in the burst.
saxigp2_awlen	I	Burst length. The burst length gives the exact number of transfers in a burst. This information determines the number of data transfers associated with the address.
saxigp2_awsiz	I	Burst size. This signal indicates the size of each transfer in the burst. Byte lane strobes indicate exactly which byte lanes to update.
saxigp2_awburst	I	Burst type. The burst type, coupled with the size information, details how the address for each transfer within the burst is calculated.
saxigp2_awlock	I	Lock type. This signal provides additional information about the atomic characteristics of the transfer.
saxigp2_awcache	I	Cache type. This signal indicates the buffer able, cacheable, write-through, write-back, and allocate attributes of the transaction.
saxigp2_awprot	I	Protection type. This signal indicates the normal, privileged, or secure protection level of the transaction and whether the transaction is a data access or an instruction access.
saxigp2_awvalid	I	Write address valid. This signal indicates that valid write address and control information are available. 1 = address and control information available 0 = address and control information not available. The address and control information remain stable until the address acknowledge signal, AWREADY, goes High.
saxigp2_awready	O	Write address channel ready signal
saxigp2_wdata	I	Write data. The write data bus can be 8, 16, 32, 64, 128, 256, 512, or 1,024 bits wide
saxigp2_wstrb	I	Write strobes. This signal indicates which byte lanes to update in memory. There is one write strobe for each eight bits of the write data bus.
saxigp2_wlast	I	Write last. This signal indicates the last transfer in a write burst.

Table B-51: S_AXI_HPO_FPD (Cont'd)

Zynq UltraScale + MPSoC PS I/O Name	I/O	Description
saxigp2_wvalid	I	Write valid. This signal indicates that valid write data and strobes are available. 1 = write data and strobes available 0 = write data and strobes not available
saxigp2_wready	O	Write ready. This signal indicates that the slave can accept the write data. 1 = slave ready 0 = slave not ready
saxigp2_bid	O	Response ID. The identification tag of the write response
saxigp2_bresp	O	Write response. This signal indicates the status of the write transaction. The allowable responses are OKAY, EXOKAY, SLVERR, and DECERR.
saxigp2_bvalid	O	Write response valid. This signal indicates that a valid write response is available. 1 = write response available 0 = write response not available
saxigp2_bready	I	Response ready. This signal indicates that the master can accept the response information. 1 = master ready 0 = master not ready
saxigp2_arid	I	Read address ID. This signal is the identification tag for the read address group of signals.
saxigp2_araddr	I	Read address. The read address bus gives the initial address of a read burst transaction.
saxigp2_arlen	I	Burst length. The burst length gives the exact number of transfers in a burst. This information determines the number of data transfers associated with the address.
saxigp2_arsize	I	Burst size. This signal indicates the size of each transfer in the burst.
saxigp2_arburst	I	Burst type. The burst type, coupled with the size information, details how the address for each transfer within the burst is calculated.
saxigp2_arlock	I	Lock type. This signal provides additional information about the atomic characteristics of the transfer.
saxigp2_arcache	I	Cache type. This signal provides additional information about the cacheable characteristics of the transfer.
saxigp2_arprot	I	Protection type. This signal provides protection unit information for the transaction.

Table B-51: S_AXI_HPO_FPD (Cont'd)

Zynq UltraScale + MPSoC PS I/O Name	I/O	Description
saxigp2_arvalid	I	Read address valid. This signal indicates, when High, that the read address and control information is valid and remains stable until the address acknowledge signal, ARREADY, is High.
saxigp2_arready	O	Read address ready. This signal indicates that the slave is ready to accept an address and associated control signals. 1 = slave ready 0 = slave not ready
saxigp2_rid	O	Read ID tag. This signal is the ID tag of the read data group of signals.
saxigp2_rdata	O	Read data. The read data bus can be 8, 16, 32, 64, 128, 256, 512, or 1,024 bits wide.
saxigp2_rresp	O	Read response. This signal indicates the status of the read transfer. The allowable responses are OKAY, EXOKAY, SLVERR, and DECERR.
saxigp2_rlast	O	Read last. This signal indicates the last transfer in a read burst.
saxigp2_rvalid	O	Read valid. This signal indicates that the required read data is available and the read transfer can complete.
saxigp2_rready	I	Read ready. This signal indicates that the master can accept the read data and response information. 1 = master ready 0 = master not ready
saxigp2_awqos	O	Wr addr channel QOS input
saxigp2_arqos	O	Rd addr channel QOS input
saxigp2_rcount	O	Rd data channel fill level
saxigp2_wcount	O	Wr data channel fill level
saxigp2_racount	O	Rd addr channel fill level
saxigp2_wacount	O	Wr addr channel fill level

Table B-52: S_AXI_HPO_FPD_ACLK

Zynq UltraScale + MPSoC PS I/O Name	I/O	Description
saxigp2_aruser	I	User-defined AR channel signals
saxihp0_fpd_aclk	I	Input clock signal

Table B-53: S_AXI_HPO_FPD_RCLK

Zynq UltraScale + MPSoC PS I/O Name	I/O	Description
saxigp2_aruser	I	User-defined AR channel signals
saxihp0_fpd_rclk	I	Read clock signal

Table B-54: S_AXI_HPO_FPD_WCLK

Zynq UltraScale + MPSoC PS I/O Name	I/O	Description
saxigp2_aruser	I	User-defined AR channel signals0
saxihp0_fpd_wclk	I	Write clock signal

Table B-55: S_AXI_HP1_FPD

Zynq UltraScale + MPSoC PS I/O Name	I/O	Description
saxigp3_aruser	I	User-defined AR channel signals
saxigp3_awuser	I	User-defined AW channel signals
saxigp3_awid	I	Write address ID. This signal is the identification tag for the write address group of signals.
saxigp3_awaddr	I	Write address. The write address bus gives the address of the first transfer in a write burst transaction. The associated control signals are used to determine the addresses of the remaining transfers in the burst.
saxigp3_awlen	I	Burst length. The burst length gives the exact number of transfers in a burst. This information determines the number of data transfers associated with the address.
saxigp3_awsiz	I	Burst size. This signal indicates the size of each transfer in the burst. Byte lane strobes indicate exactly which byte lanes to update.
saxigp3_awburst	I	Burst type. The burst type, coupled with the size information, details how the address for each transfer within the burst is calculated.
saxigp3_awlock	I	Lock type. This signal provides additional information about the atomic characteristics of the transfer.
saxigp3_awcache	I	Cache type. This signal indicates the buffer able, cacheable, write-through, write-back, and allocate attributes of the transaction.
saxigp3_awprot	I	Protection type. This signal indicates the normal, privileged, or secure protection level of the transaction and whether the transaction is a data access or an instruction access.

Table B-55: S_AXI_HP1_FPD (Cont'd)

Zynq UltraScale + MPSoC PS I/O Name	I/O	Description
saxigp3_awvalid	I	Write address valid. This signal indicates that valid write address and control information are available. 1 = address and control information available 0 = address and control information not available The address and control information remain stable until the address acknowledge signal, AWREADY, goes High.
saxigp3_awready	O	Write address channel ready signal
saxigp3_wdata	I	Write data. The write data bus can be 8, 16, 32, 64, 128, 256, 512, or 1,024 bits wide.
saxigp3_wstrb	I	Write strobes. This signal indicates which byte lanes to update in memory. There is one write strobe for each eight bits of the write data bus.
saxigp3_wlast	I	Write last. This signal indicates the last transfer in a write burst.
saxigp3_wvalid	I	Write valid. This signal indicates that valid write data and strobes are available. 1 = write data and strobes available 0 = write data and strobes not available
saxigp3_wready	O	Write ready. This signal indicates that the slave can accept the write data. 1 = slave ready 0 = slave not ready
saxigp3_bid	O	Response ID. The identification tag of the write response
saxigp3_bresp	O	Write response. This signal indicates the status of the write transaction. The allowable responses are OKAY, EXOKAY, SLVERR, and DECERR.
saxigp3_bvalid	O	Write response valid. This signal indicates that a valid write response is available. 1 = write response available 0 = write response not available
saxigp3_bready	I	Response ready. This signal indicates that the master can accept the response information. 1 = master ready 0 = master not ready
saxigp3_arid	I	Read address ID. This signal is the identification tag for the read address group of signals.
saxigp3_araddr	I	Read address. The read address bus gives the initial address of a read burst transaction.
saxigp3_aren	I	Burst length. The burst length gives the exact number of transfers in a burst. This information determines the number of data transfers associated with the address.

Table B-55: S_AXI_HP1_FPD (Cont'd)

Zynq UltraScale + MPSoC PS I/O Name	I/O	Description
saxigp3_arsize	I	Burst size. This signal indicates the size of each transfer in the burst
saxigp3_arburst	I	Burst type. The burst type, coupled with the size information, details how the address for each transfer within the burst is calculated.
saxigp3_arlock	I	Lock type. This signal provides additional information about the atomic characteristics of the transfer.
saxigp3_arcache	I	Cache type. This signal provides additional information about the cacheable characteristics of the transfer.
saxigp3_arprot	I	Protection type. This signal provides protection unit information for the transaction.
saxigp3_arvalid	I	Read address valid. This signal indicates, when High, that the read address and control information is valid and remains stable until the address acknowledge signal, ARREADY, is High.
saxigp3_arready	O	Read address ready. This signal indicates that the slave is ready to accept an address and associated control signals. 1 = slave ready 0 = slave not ready
saxigp3_rid	O	Read ID tag. This signal is the ID tag of the read data group of signals.
saxigp3_rdata	O	Read data. The read data bus can be 8, 16, 32, 64, 128, 256, 512, or 1,024 bits wide.
saxigp3_rresp	O	Read response. This signal indicates the status of the read transfer. The allowable responses are OKAY, EXOKAY, SLVERR, and DECERR.
saxigp3_rlast	O	Read last. This signal indicates the last transfer in a read burst.
saxigp3_rvalid	O	Read valid. This signal indicates that the required read data is available and the read transfer can complete.
saxigp3_rready	I	Read ready. This signal indicates that the master can accept the read data and response information. 1 = master ready 0 = master not ready
saxigp3_awqos	O	Wr addr channel QOS input
saxigp3_arqos	O	Rd addr channel QOS input
saxigp3_rcount	O	Rd data channel fill level
saxigp3_wcount	O	Wr data channel fill level
saxigp3_racount	O	Rd addr channel fill level
saxigp3_wacount	O	Wr addr channel fill level

Table B-56: S_AXI_HP1_FPD_ACLK

Zynq UltraScale + MPSoC PS I/O Name	I/O	Description
saxigp3_aruser	I	User-defined AR channel signals
Saxihp1_fpd_aclk	I	Input clock signal

Table B-57: S_AXI_HP1_FPD_RCLK

Zynq UltraScale + MPSoC PS I/O Name	I/O	Description
saxigp3_aruser	I	User-defined AR channel signals
Saxihp1_fpd_rclk	I	Read clock signal

Table B-58: S_AXI_HP1_FPD_WCLK

Zynq UltraScale + MPSoC PS I/O Name	I/O	Description
saxigp3_aruser	I	User-defined AR channel signals
saxihp1_fpd_wclk	I	Write clock signal

Table B-59: S_AXI_HP2_FPD

Zynq UltraScale + MPSoC PS I/O Name	I/O	Description
saxigp4_aruser	I	User-defined AR channel signals
saxigp4_awuser	I	User-defined AW channel signals
saxigp4_awid	I	Write address ID. This signal is the identification tag for the write address group of signals.
saxigp4_awaddr	I	Write address. The write address bus gives the address of the first transfer in a write burst transaction. The associated control signals are used to determine the addresses of the remaining transfers in the burst.
saxigp4_awlen	I	Burst length. The burst length gives the exact number of transfers in a burst. This information determines the number of data transfers associated with the address.
saxigp4_awsz	I	Burst size. This signal indicates the size of each transfer in the burst. Byte lane strobes indicate exactly which byte lanes to update.
saxigp4_awburst	I	Burst type. The burst type, coupled with the size information, details how the address for each transfer within the burst is calculated.

Table B-59: S_AXI_HP2_FPD (Cont'd)

Zynq UltraScale + MPSoC PS I/O Name	I/O	Description
saxigp4_awlock	I	Lock type. This signal provides additional information about the atomic characteristics of the transfer.
saxigp4_awcache	I	Cache type. This signal indicates the buffer able, cacheable, write-through, write-back, and allocate attributes of the transaction.
saxigp4_awprot	I	Protection type. This signal indicates the normal, privileged, or secure protection level of the transaction and whether the transaction is a data access or an instruction access.
saxigp4_awvalid	I	Write address valid. This signal indicates that valid write address and control information are available. 1 = address and control information available 0 = address and control information not available The address and control information remain stable until the address acknowledge signal, AWREADY, goes High.
saxigp4_awready	O	Write address channel ready signal
saxigp4_wdata	I	Write data. The write data bus can be 8, 16, 32, 64, 128, 256, 512, or 1,024 bits wide.
saxigp4_wstrb	I	Write strobes. This signal indicates which byte lanes to update in memory. There is one write strobe for each eight bits of the write data bus.
saxigp4_wlast	I	Write last. This signal indicates the last transfer in a write burst.
saxigp4_wvalid	I	Write valid. This signal indicates that valid write data and strobes are available. 1 = write data and strobes available 0 = write data and strobes not available
saxigp4_wready	O	Write ready. This signal indicates that the slave can accept the write data. 1 = slave ready 0 = slave not ready
saxigp4_bid	O	Response ID. The identification tag of the write response
saxigp4_bresp	O	Write response. This signal indicates the status of the write transaction. The allowable responses are OKAY, EXOKAY, SLVERR, and DECERR.
saxigp4_bvalid	O	Write response valid. This signal indicates that a valid write response is available. 1 = write response available 0 = write response not available

Table B-59: S_AXI_HP2_FPD (Cont'd)

Zynq UltraScale + MPSoC PS I/O Name	I/O	Description
saxigp4_bready	I	Response ready. This signal indicates that the master can accept the response information. 1 = master ready 0 = master not ready
saxigp4_arid	I	Read address ID. This signal is the identification tag for the read address group of signals.
saxigp4_araddr	I	Read address. The read address bus gives the initial address of a read burst transaction.
saxigp4_arnlen	I	Burst length. The burst length gives the exact number of transfers in a burst. This information determines the number of data transfers associated with the address.
saxigp4_arsize	I	Burst size. This signal indicates the size of each transfer in the burst.
saxigp4_arburst	I	Burst type. The burst type, coupled with the size information, details how the address for each transfer within the burst is calculated.
saxigp4_arlock	I	Lock type. This signal provides additional information about the atomic characteristics of the transfer.
saxigp4_arcache	I	Cache type. This signal provides additional information about the cacheable characteristics of the transfer.
saxigp4_arprot	I	Protection type. This signal provides protection unit information for the transaction.
saxigp4_arvalid	I	Read address valid. This signal indicates, when High, that the read address and control information is valid and remains stable until the address acknowledge signal, ARREADY, is High.
saxigp4_arready	O	Read address ready. This signal indicates that the slave is ready to accept an address and associated control signals. 1 = slave ready 0 = slave not ready
saxigp4_rid	O	Read ID tag. This signal is the ID tag of the read data group of signals.
saxigp4_rdata	O	Read data. The read data bus can be 8, 16, 32, 64, 128, 256, 512, or 1,024 bits wide.
saxigp4_rresp	O	Read response. This signal indicates the status of the read transfer. The allowable responses are OKAY, EXOKAY, SLVERR, and DECERR.
saxigp4_rlast	O	Read last. This signal indicates the last transfer in a read burst.
saxigp4_rvalid	O	Read valid. This signal indicates that the required read data is available and the read transfer can complete.

Table B-59: S_AXI_HP2_FPD (Cont'd)

Zynq UltraScale + MPSoC PS I/O Name	I/O	Description
saxigp4_rready	I	Read ready. This signal indicates that the master can accept the read data and response information. 1= master ready 0 = master not ready
saxigp4_awqos	O	Wr addr channel QOS input
saxigp4_arqos	O	Rd addr channel QOS input
saxigp4_rcount	O	Rd data channel fill level
saxigp4_wcount	O	Wr data channel fill level
saxigp4_racount	O	Rd addr channel fill level
saxigp4_wacount	O	Wr addr channel fill level

Table B-60: S_AXI_HP2_FPD_ACLK

Zynq UltraScale + MPSoC PS I/O Name	I/O	Description
saxigp4_aruser	I	User-defined AR channel signals
Saxihp2_fpd_aclk	I	Input clock signal

Table B-61: S_AXI_HP2_FPD_RCLK

Zynq UltraScale + MPSoC PS I/O Name	I/O	Description
saxigp4_aruser	I	User-defined AR channel signals
Saxihp2_fpd_rclk	I	Read clock signal

Table B-62: S_AXI_HP2_FPD_WCLK

Zynq UltraScale + MPSoC PS I/O Name	I/O	Description
saxigp4_aruser	I	User-defined AR channel signals
Saxihp2_fpd_wclk	I	Write clock signal

Table B-63: S_AXI_HP3_FPD

Zynq UltraScale + MPSoC PS I/O Name	I/O	Description
saxigp5_aruser	I	User-defined AR channel signals
saxigp5_awuser	I	User-defined AW channel signals
saxigp5_awid	I	Write address ID. This signal is the identification tag for the write address group of signals.
saxigp5_awaddr	I	Write address. The write address bus gives the address of the first transfer in a write burst transaction. The associated control signals are used to determine the addresses of the remaining transfers in the burst.
saxigp5_awlen	I	Burst length. The burst length gives the exact number of transfers in a burst. This information determines the number of data transfers associated with the address.
saxigp5_awsz	I	Burst size. This signal indicates the size of each transfer in the burst. Byte lane strobes indicate exactly which byte lanes to update.
saxigp5_awburst	I	Burst type. The burst type, coupled with the size information, details how the address for each transfer within the burst is calculated.
saxigp5_awlock	I	Lock type. This signal provides additional information about the atomic characteristics of the transfer.
saxigp5_awcache	I	Cache type. This signal indicates the buffer able, cacheable, write-through, write-back, and allocate attributes of the transaction.
saxigp5_awprot	I	Protection type. This signal indicates the normal, privileged, or secure protection level of the transaction and whether the transaction is a data access or an instruction access.
saxigp5_awvalid	I	Write address valid. This signal indicates that valid write address and control information are available. 1 = address and control information available 0 = address and control information not available The address and control information remain stable until the address acknowledge signal, AWREADY, goes High.
saxigp5_awready	O	Write address channel ready signal
saxigp5_wdata	I	Write data. The write data bus can be 8, 16, 32, 64, 128, 256, 512, or 1,024 bits wide.
saxigp5_wstrb	I	Write strobes. This signal indicates which byte lanes to update in memory. There is one write strobe for each eight bits of the write data bus.
saxigp5_wlast	I	Write last. This signal indicates the last transfer in a write burst.

Table B-63: S_AXI_HP3_FPD (Cont'd)

Zynq UltraScale + MPSoC PS I/O Name	I/O	Description
saxigp5_wvalid	I	Write valid. This signal indicates that valid write data and strobes are available. 1 = write data and strobes available 0 = write data and strobes not available
saxigp5_wready	O	Write ready. This signal indicates that the slave can accept the write data. 1 = slave ready 0 = slave not ready
saxigp5_bid	O	Response ID. The identification tag of the write response
saxigp5_bresp	O	Write response. This signal indicates the status of the write transaction. The allowable responses are OKAY, EXOKAY, SLVERR, and DECERR.
saxigp5_bvalid	O	Write response valid. This signal indicates that a valid write response is available. 1 = write response available 0 = write response not available
saxigp5_bready	I	Response ready. This signal indicates that the master can accept the response information. 1 = master ready 0 = master not ready
saxigp5_arid	I	Read address ID. This signal is the identification tag for the read address group of signals.
saxigp5_araddr	I	Read address. The read address bus gives the initial address of a read burst transaction.
saxigp5_arlen	I	Burst length. The burst length gives the exact number of transfers in a burst. This information determines the number of data transfers associated with the address.
saxigp5_arsize	I	Burst size. This signal indicates the size of each transfer in the burst.
saxigp5_arburst	I	Burst type. The burst type, coupled with the size information, details how the address for each transfer within the burst is calculated.
saxigp5_arlock	I	Lock type. This signal provides additional information about the atomic characteristics of the transfer.
saxigp5_arcache	I	Cache type. This signal provides additional information about the cacheable characteristics of the transfer.
saxigp5_arprot	I	Protection type. This signal provides protection unit information for the transaction.

Table B-63: S_AXI_HP3_FPD (Cont'd)

Zynq UltraScale + MPSoC PS I/O Name	I/O	Description
saxigp5_arvalid	I	Read address valid. This signal indicates, when High, that the read address and control information is valid and remains stable until the address acknowledge signal, ARREADY, is High.
saxigp5_arready	O	Read address ready. This signal indicates that the slave is ready to accept an address and associated control signals. 1 = slave ready 0 = slave not ready
saxigp5_rid	O	Read ID tag. This signal is the ID tag of the read data group of signals.
saxigp5_rdata	O	Read data. The read data bus can be 8, 16, 32, 64, 128, 256, 512, or 1,024 bits wide.
saxigp5_rresp	O	Read response. This signal indicates the status of the read transfer. The allowable responses are OKAY, EXOKAY, SLVERR, and DECERR.
saxigp5_rlast	O	Read last. This signal indicates the last transfer in a read burst.
saxigp5_rvalid	O	Read valid. This signal indicates that the required read data is available and the read transfer can complete.
saxigp5_rready	I	Read ready. This signal indicates that the master can accept the read data and response information. 1= master ready 0 = master not ready
saxigp5_awqos	O	Wr addr channel QOS input
saxigp5_arqos	O	Rd addr channel QOS input
saxigp5_rcount	O	Rd data channel fill level
saxigp5_wcount	O	Wr data channel fill level
saxigp5_racount	O	Rd addr channel fill level
saxigp5_wacount	O	Wr addr channel fill level

Table B-64: S_AXI_HP3_FPD_ACLK

Zynq UltraScale + MPSoC PS I/O Name	I/O	Description
saxigp5_aruser	I	User-defined AR channel signals
Saxihp3_fpd_aclk	I	Input clock signal

Table B-65: S_AXI_HP3_FPD_RCLK

Zynq UltraScale + MPSoC PS I/O Name	I/O	Description
saxigp5_aruser	I	User-defined AR channel signals
Saxihp3_fpd_rclk	I	Read clock signal

Table B-66: S_AXI_HP1_FPD_WCLK

Zynq UltraScale + MPSoC PS I/O Name	I/O	Description
saxigp5_aruser	I	User-defined AR channel signals
Saxihp3_fpd_wclk	I	Write clock signal

Table B-67: S_AXI_HPC0_FPD

Zynq UltraScale + MPSoC PS I/O Name	I/O	Description
saxigp0_aruser	I	User-defined AR channel signals
saxigp0_awuser	I	User-defined AW channel signals
saxigp0_awid	I	Write address ID. This signal is the identification tag for the write address group of signals.
saxigp0_awaddr	I	Write address. The write address bus gives the address of the first transfer in a write burst transaction. The associated control signals are used to determine the addresses of the remaining transfers in the burst.
saxigp0_awlen	I	Burst length. The burst length gives the exact number of transfers in a burst. This information determines the number of data transfers associated with the address.
saxigp0_awsiz	I	Burst size. This signal indicates the size of each transfer in the burst. Byte lane strobes indicate exactly which byte lanes to update.
saxigp0_awburst	I	Burst type. The burst type, coupled with the size information, details how the address for each transfer within the burst is calculated.
saxigp0_awlock	I	Lock type. This signal provides additional information about the atomic characteristics of the transfer.
saxigp0_awcache	I	Cache type. This signal indicates the buffer able, cacheable, write-through, write-back, and allocate attributes of the transaction.
saxigp0_awprot	I	Protection type. This signal indicates the normal, privileged, or secure protection level of the transaction and whether the transaction is a data access or an instruction access.

Table B-67: S_AXI_HPC0_FPD (Cont'd)

Zynq UltraScale + MPSoC PS I/O Name	I/O	Description
saxigp0_awvalid	I	Write address valid. This signal indicates that valid write address and control information are available. 1 = address and control information available 0 = address and control information not available The address and control information remain stable until the address acknowledge signal, AWREADY, goes High.
saxigp0_awready	O	Write address channel ready signal
saxigp0_wdata	I	Write data. The write data bus can be 8, 16, 32, 64, 128, 256, 512, or 1,024 bits wide.
saxigp0_wstrb	I	Write strobes. This signal indicates which byte lanes to update in memory. There is one write strobe for each eight bits of the write data bus.
saxigp0_wlast	I	Write last. This signal indicates the last transfer in a write burst.
saxigp0_wvalid	I	Write valid. This signal indicates that valid write data and strobes are available. 1 = write data and strobes available 0 = write data and strobes not available
saxigp0_wready	O	Write ready. This signal indicates that the slave can accept the write data. 1 = slave ready 0 = slave not ready
saxigp0_bid	O	Response ID. The identification tag of the write response
saxigp0_bresp	O	Write response. This signal indicates the status of the write transaction. The allowable responses are OKAY, EXOKAY, SLVERR, and DECERR.
saxigp0_bvalid	O	Write response valid. This signal indicates that a valid write response is available. 1 = write response available 0 = write response not available
saxigp0_bready	I	Response ready. This signal indicates that the master can accept the response information. 1 = master ready 0 = master not ready
saxigp0_arid	I	Read address ID. This signal is the identification tag for the read address group of signals.
saxigp0_araddr	I	Read address. The read address bus gives the initial address of a read burst transaction.
saxigp0_aren	I	Burst length. The burst length gives the exact number of transfers in a burst. This information determines the number of data transfers associated with the address.

Table B-67: S_AXI_HPC0_FPD (Cont'd)

Zynq UltraScale + MPSoC PS I/O Name	I/O	Description
saxigp0_arsize	I	Burst size. This signal indicates the size of each transfer in the burst.
saxigp0_arburst	I	Burst type. The burst type, coupled with the size information, details how the address for each transfer within the burst is calculated.
saxigp0_arlock	I	Lock type. This signal provides additional information about the atomic characteristics of the transfer.
saxigp0_arcache	I	Cache type. This signal provides additional information about the cacheable characteristics of the transfer.
saxigp0_arprot	I	Protection type. This signal provides protection unit information for the transaction.
saxigp0_arvalid	I	Read address valid. This signal indicates, when High, that the read address and control information is valid and remains stable until the address acknowledge signal, ARREADY, is High.
saxigp0_arready	O	Read address ready. This signal indicates that the slave is ready to accept an address and associated control signals. 1 = slave ready 0 = slave not ready.
saxigp0_rid	O	Read ID tag. This signal is the ID tag of the read data group of signals.
saxigp0_rdata	O	Read data. The read data bus can be 8, 16, 32, 64, 128, 256, 512, or 1,024 bits wide.
saxigp0_rresp	O	Read response. This signal indicates the status of the read transfer. The allowable responses are OKAY, EXOKAY, SLVERR, and DECERR.
saxigp0_rlast	O	Read last. This signal indicates the last transfer in a read burst.
saxigp0_rvalid	O	Read valid. This signal indicates that the required read data is available and the read transfer can complete.
saxigp0_rready	I	Read ready. This signal indicates that the master can accept the read data and response information. 1 = master ready 0 = master not ready
saxigp0_awqos	O	Wr addr channel QOS input
saxigp0_arqos	O	Rd addr channel QOS input
saxigp0_rcount	O	Rd data channel fill level
saxigp0_wcount	O	Wr data channel fill level
saxigp0_racount	O	Rd addr channel fill level
saxigp0_wacount	O	Wr addr channel fill level

Table B-68: S_AXI_HPC0_FPD_ACLK

Zynq UltraScale + MPSoC PS I/O Name	I/O	Description
saxigp0_aruser	I	User-defined AR channel signals
saxihpc0_fpd_aclk	I	Input clock signal

Table B-69: S_AXI_HPC0_FPD_RCLK

Zynq UltraScale + MPSoC PS I/O Name	I/O	Description
saxigp0_aruser	I	User-defined AR channel signals
saxihpc0_fpd_rclk	I	Read clock signal

Table B-70: S_AXI_HPC0_FPD_WCLK

Zynq UltraScale + MPSoC PS I/O Name	I/O	Description
saxigp0_aruser	I	User-defined AR channel signals
saxihpc0_fpd_wclk	I	Write clock signal

Table B-71: S_AXI_HPC1_FPD

Zynq UltraScale + MPSoC PS I/O Name	I/O	Description
Saxigp1_aruser	I	User-defined AR channel signals
Saxigp1_awuser	I	User-defined AW channel signals
Saxigp1_awid	I	Write address ID. This signal is the identification tag for the write address group of signals.
Saxigp1_awaddr	I	Write address. The write address bus gives the address of the first transfer in a write burst transaction. The associated control signals are used to determine the addresses of the remaining transfers in the burst.
Saxigp1_awlen	I	Burst length. The burst length gives the exact number of transfers in a burst. This information determines the number of data transfers associated with the address.
Saxigp1_awsiz	I	Burst size. This signal indicates the size of each transfer in the burst. Byte lane strobes indicate exactly which byte lanes to update.
Saxigp1_awburst	I	Burst type. The burst type, coupled with the size information, details how the address for each transfer within the burst is calculated.

Table B-71: S_AXI_HPC1_FPD (Cont'd)

Zynq UltraScale + MPSoC PS I/O Name	I/O	Description
Saxigp1_awlock	I	Lock type. This signal provides additional information about the atomic characteristics of the transfer.
Saxigp1_awcache	I	Cache type. This signal indicates the buffer able, cacheable, write-through, write-back, and allocate attributes of the transaction.
Saxigp1_awprot	I	Protection type. This signal indicates the normal, privileged, or secure protection level of the transaction and whether the transaction is a data access or an instruction access.
Saxigp1_awvalid	I	Write address valid. This signal indicates that valid write address and control information are available. 1 = address and control information available 0 = address and control information not available The address and control information remain stable until the address acknowledge signal, AWREADY, goes High.
Saxigp1_awready	O	Write address channel ready signal
Saxigp1_wdata	I	Write data. The write data bus can be 8, 16, 32, 64, 128, 256, 512, or 1,024 bits wide.
Saxigp1_wstrb	I	Write strobes. This signal indicates which byte lanes to update in memory. There is one write strobe for each eight bits of the write data bus.
Saxigp1_wlast	I	Write last. This signal indicates the last transfer in a write burst.
Saxigp1_wvalid	I	Write valid. This signal indicates that valid write data and strobes are available. 1 = write data and strobes available 0 = write data and strobes not available
Saxigp1_wready	O	Write ready. This signal indicates that the slave can accept the write data. 1 = slave ready 0 = slave not ready
Saxigp1_bid	O	Response ID. The identification tag of the write response
Saxigp1_bresp	O	Write response. This signal indicates the status of the write transaction. The allowable responses are OKAY, EXOKAY, SLVERR, and DECERR.
Saxigp1_bvalid	O	Write response valid. This signal indicates that a valid write response is available. 1 = write response available 0 = write response not available

Table B-71: S_AXI_HPC1_FPD (Cont'd)

Zynq UltraScale + MPSoC PS I/O Name	I/O	Description
Saxigp1_bready	I	Response ready. This signal indicates that the master can accept the response information. 1 = master ready 0 = master not ready
Saxigp1_arid	I	Read address ID. This signal is the identification tag for the read address group of signals.
Saxigp1_araddr	I	Read address. The read address bus gives the initial address of a read burst transaction.
Saxigp1_arnlen	I	Burst length. The burst length gives the exact number of transfers in a burst. This information determines the number of data transfers associated with the address.
Saxigp1_arsize	I	Burst size. This signal indicates the size of each transfer in the burst.
Saxigp1_arburst	I	Burst type. The burst type, coupled with the size information, details how the address for each transfer within the burst is calculated.
Saxigp1_arlock	I	Lock type. This signal provides additional information about the atomic characteristics of the transfer.
Saxigp1_arcache	I	Cache type. This signal provides additional information about the cacheable characteristics of the transfer.
Saxigp1_arprot	I	Protection type. This signal provides protection unit information for the transaction.
Saxigp1_arvalid	I	Read address valid. This signal indicates, when High, that the read address and control information is valid and remains stable until the address acknowledge signal, ARREADY, is High.
Saxigp1_arready	O	Read address ready. This signal indicates that the slave is ready to accept an address and associated control signals. 1 = slave ready 0 = slave not ready
Saxigp1_rid	O	Read ID tag. This signal is the ID tag of the read data group of signals.
Saxigp1_rdata	O	Read data. The read data bus can be 8, 16, 32, 64, 128, 256, 512, or 1,024 bits wide.
Saxigp1_rresp	O	Read response. This signal indicates the status of the read transfer. The allowable responses are OKAY, EXOKAY, SLVERR, and DECERR.
Saxigp1_rlast	O	Read last. This signal indicates the last transfer in a read burst.
Saxigp1_rvalid	O	Read valid. This signal indicates that the required read data is available and the read transfer can complete.

Table B-71: S_AXI_HPC1_FPD (Cont'd)

Zynq UltraScale + MPSoC PS I/O Name	I/O	Description
Saxigp1_rready	I	Read ready. This signal indicates that the master can accept the read data and response information. 1= master ready 0 = master not ready
Saxigp1_awqos	O	Wr addr channel QOS input
Saxigp1_arqos	O	Rd addr channel QOS input
Saxigp1_rcount	O	Rd data channel fill level
Saxigp1_wcount	O	Wr data channel fill level
Saxigp1_racount	O	Rd addr channel fill level
Saxigp1_wacount	O	Wr addr channel fill level

Table B-72: S_AXI_HPC1_FPD_ACLK

Zynq UltraScale + MPSoC PS I/O Name	I/O	Description
Saxigp1_aruser	I	User-defined AR channel signals
Saxihpc1_fpd_aclk	I	Input clock signal

Table B-73: S_AXI_HPC1_FPD_RCLK

Zynq UltraScale + MPSoC PS I/O Name	I/O	Description
Saxigp1_aruser	I	User-defined AR channel signals
Saxihpc1_fpd_rclk	I	Read clock signal

Table B-74: S_AXI_HPC1_FPD_WCLK

Zynq UltraScale + MPSoC PS I/O Name	I/O	Description
Saxigp1_aruser	I	User-defined AR channel signals
Saxihpc1_fpd_wclk	I	Write clock signal

Table B-75: S_AXI_PL_LPD

Zynq UltraScale + MPSoC PS I/O Name	I/O	Description
saxigp6_aruser	I	User-defined AR channel signals
saxigp6_awuser	I	User-defined AW channel signals
saxigp6_awid	I	Write address ID. This signal is the identification tag for the write address group of signals.
saxigp6_awaddr	I	Write address. The write address bus gives the address of the first transfer in a write burst transaction. The associated control signals are used to determine the addresses of the remaining transfers in the burst.
saxigp6_awlen	I	Burst length. The burst length gives the exact number of transfers in a burst. This information determines the number of data transfers associated with the address.
saxigp6_awsz	I	Burst size. This signal indicates the size of each transfer in the burst. Byte lane strobes indicate exactly which byte lanes to update.
saxigp6_awburst	I	Burst type. The burst type, coupled with the size information, details how the address for each transfer within the burst is calculated.
saxigp6_awlock	I	Lock type. This signal provides additional information about the atomic characteristics of the transfer.
saxigp6_awcache	I	Cache type. This signal indicates the buffer able, cacheable, write-through, write-back, and allocate attributes of the transaction.
saxigp6_awprot	I	Protection type. This signal indicates the normal, privileged, or secure protection level of the transaction and whether the transaction is a data access or an instruction access.
saxigp6_awvalid	I	Write address valid. This signal indicates that valid write address and control information are available. 1 = address and control information available 0 = address and control information not available The address and control information remain stable until the address acknowledge signal, AWREADY, goes High.
saxigp6_awready	O	Write address channel ready signal
saxigp6_wdata	I	Write data. The write data bus can be 8, 16, 32, 64, 128, 256, 512, or 1,024 bits wide.
saxigp6_wstrb	I	Write strobes. This signal indicates which byte lanes to update in memory. There is one write strobe for each eight bits of the write data bus.
saxigp6_wlast	I	Write last. This signal indicates the last transfer in a write burst.

Table B-75: S_AXI_PL_LPD (Cont'd)

Zynq UltraScale + MPSoC PS I/O Name	I/O	Description
saxigp6_wvalid	I	Write valid. This signal indicates that valid write data and strobes are available. 1 = write data and strobes available 0 = write data and strobes not available
saxigp6_wready	O	Write ready. This signal indicates that the slave can accept the write data. 1 = slave ready 0 = slave not ready
saxigp6_bid	O	Response ID. The identification tag of the write response
saxigp6_bresp	O	Write response. This signal indicates the status of the write transaction. The allowable responses are OKAY, EXOKAY, SLVERR, and DECERR.
saxigp6_bvalid	O	Write response valid. This signal indicates that a valid write response is available. 1 = write response available 0 = write response not available
saxigp6_bready	I	Response ready. This signal indicates that the master can accept the response information. 1 = master ready 0 = master not ready
saxigp6_arid	I	Read address ID. This signal is the identification tag for the read address group of signals.
saxigp6_araddr	I	Read address. The read address bus gives the initial address of a read burst transaction.
saxigp6_arnlen	I	Burst length. The burst length gives the exact number of transfers in a burst. This information determines the number of data transfers associated with the address.
saxigp6_arsize	I	Burst size. This signal indicates the size of each transfer in the burst.
saxigp6_arburst	I	Burst type. The burst type, coupled with the size information, details how the address for each transfer within the burst is calculated.
saxigp6_arlock	I	Lock type. This signal provides additional information about the atomic characteristics of the transfer.
saxigp6_arcache	I	Cache type. This signal provides additional information about the cacheable characteristics of the transfer.
saxigp6_arprot	I	Protection type. This signal provides protection unit information for the transaction.

Table B-75: S_AXI_PL_LPD (Cont'd)

Zynq UltraScale + MPSoC PS I/O Name	I/O	Description
saxigp6_arvalid	I	Read address valid. This signal indicates, when High, that the read address and control information is valid and remains stable until the address acknowledge signal, ARREADY, is High.
saxigp6_arready	O	Read address ready. This signal indicates that the slave is ready to accept an address and associated control signals. 1 = slave ready 0 = slave not ready
saxigp6_rid	O	Read ID tag. This signal is the ID tag of the read data group of signals.
saxigp6_rdata	O	Read data. The read data bus can be 8, 16, 32, 64, 128, 256, 512, or 1,024 bits wide.
saxigp6_rresp	O	Read response. This signal indicates the status of the read transfer. The allowable responses are OKAY, EXOKAY, SLVERR, and DECERR.
saxigp6_rlast	O	Read last. This signal indicates the last transfer in a read burst.
saxigp6_rvalid	O	Read valid. This signal indicates that the required read data is available and the read transfer can complete.
saxigp6_rready	I	Read ready. This signal indicates that the master can accept the read data and response information. 1 = master ready 0 = master not ready
saxigp6_awqos	O	Wr addr channel QOS input
saxigp6_arqos	O	Rd addr channel QOS input
saxigp6_rcount	O	Rd data channel fill level
saxigp6_wcount	O	Wr data channel fill level
saxigp6_racount	O	Rd addr channel fill level
saxigp6_wacount	O	Wr addr channel fill level

Table B-76: S_AXI_PL_LPD_ACLK

Zynq UltraScale + MPSoC PS I/O Name	I/O	Description
saxigp6_aruser	I	User-defined AR channel signals
saxipl_lpd_aclk	I	Input clock signal

Table B-77: S_AXI_PL_LPD_RCLK

Zynq UltraScale + MPSoC PS I/O Name	I/O	Description
saxigp6_aruser	I	User-defined AR channel signals
saxipl_lpd_rclk	I	Read clock signal

Table B-78: S_AXI_PL_LPD_WCLK

Zynq UltraScale + MPSoC PS I/O Name	I/O	Description
saxigp6_aruser	I	User-defined AR channel signals
saxipl_lpd_wclk	I	Write clock signal

User Parameters

Table C-1: User Parameters

Parameter Description	Parameters	Range	Default Values
PSS Input frequency	PSU__PSS_REF_CLK__FREQMHZ		33.333
	PSU__PSS_ALT_REF_CLK__FREQMHZ		33.333
Video Ref Clk Frequency	PSU__VIDEO_REF_CLK__FREQMHZ		33.333
	PSU__AUX_REF_CLK__FREQMHZ		33.333
	PSU__GT_REF_CLK__FREQMHZ		33.333
	PSU__VIDEO_REF_CLK__ENABLE	0,1	0
	PSU__VIDEO_REF_CLK__IO	<Select>,MIO 27,MIO 50	<Select>
	PSU__PSS_ALT_REF_CLK__ENABLE	0,1	0
	PSU__PSS_ALT_REF_CLK__IO	<Select>,MIO 28,MIO 51	<Select>
CAN Peripheral Related parameters	PSU__CAN0__PERIPHERAL__ENABLE	0,1	0
	PSU__CAN0__PERIPHERAL__IO	<Select>,EMIO,MIO 2 .. 3, MIO 6 .. 7,MIO 10 .. 11, MIO 14 .. 15,MIO 18 .. 19, MIO 22 .. 23,MIO 26 .. 27, MIO 30 .. 31,MIO 34 .. 35, MIO 38 .. 39,MIO 42 .. 43, MIO 46 .. 47,MIO 50 .. 51, MIO 54 .. 55,MIO 58 .. 59, MIO 62 .. 63,MIO 66 .. 67, MIO 70 .. 71,MIO 74 .. 75	<Select>
	PSU__CAN0__GRP_CLK__ENABLE	0,1	0

Table C-1: User Parameters (Cont'd)

Parameter Description	Parameters	Range	Default Values
CAN Peripheral Related parameters (continued)	PSU__CAN0__GRP_CLK__IO	<Select>, MIO 0, MIO 1, MIO 2, MIO 3, MIO 4, MIO 5, MIO 6, MIO 7, MIO 8, MIO 9, MIO 10, MIO 11, MIO 12, MIO 13, MIO 14, MIO 15, MIO 16, MIO 17, MIO 18, MIO 19, MIO 20, MIO 21, MIO 22, MIO 23, MIO 24, MIO 25, MIO 26, MIO 27, MIO 28, MIO 29, MIO 30, MIO 31, MIO 32, MIO 33, MIO 34, MIO 35, MIO 36, MIO 37, MIO 38, MIO 39, MIO 40, MIO 41, MIO 42, MIO 43, MIO 44, MIO 45, MIO 46, MIO 47, MIO 48, MIO 49, MIO 50, MIO 51, MIO 52, MIO 53, MIO 54, MIO 55, MIO 56, MIO 57, MIO 58, MIO 59, MIO 60, MIO 61, MIO 62, MIO 63, MIO 64, MIO 65, MIO 66, MIO 67, MIO 68, MIO 69, MIO 70, MIO 71, MIO 72, MIO 73, MIO 74, MIO 75, MIO 76, MIO 77	<Select>
	PSU__CAN1__PERIPHERAL__ENABLE	0,1	0
	PSU__CAN1__PERIPHERAL__IO	<Select>, EMIO, MIO 0 .. 1, MIO 4 .. 5, MIO 8 .. 9, MIO 12 .. 13, MIO 16 .. 17, MIO 20 .. 21, MIO 24 .. 25, MIO 28 .. 29, MIO 32 .. 33, MIO 36 .. 37, MIO 40 .. 41, MIO 44 .. 45, MIO 48 .. 49, MIO 52 .. 53, MIO 56 .. 57, MIO 60 .. 61, MIO 64 .. 65, MIO 68 .. 69, MIO 72 .. 73, MIO 76 .. 77	<Select>
	PSU__CAN1__GRP_CLK__ENABLE	0,1	0

Table C-1: User Parameters (Cont'd)

Parameter Description	Parameters	Range	Default Values
CAN Peripheral Related parameters (continued)	PSU__CAN1__GRP_CLK__IO	<Select>, MIO 0, MIO 1, MIO 2, MIO 3, MIO 4, MIO 5, MIO 6, MIO 7, MIO 8, MIO 9, MIO 10, MIO 11, MIO 12, MIO 13, MIO 14, MIO 15, MIO 16, MIO 17, MIO 18, MIO 19, MIO 20, MIO 21, MIO 22, MIO 23, MIO 24, MIO 25, MIO 26, MIO 27, MIO 28, MIO 29, MIO 30, MIO 31, MIO 32, MIO 33, MIO 34, MIO 35, MIO 36, MIO 37, MIO 38, MIO 39, MIO 40, MIO 41, MIO 42, MIO 43, MIO 44, MIO 45, MIO 46, MIO 47, MIO 48, MIO 49, MIO 50, MIO 51, MIO 52, MIO 53, MIO 54, MIO 55, MIO 56, MIO 57, MIO 58, MIO 59, MIO 60, MIO 61, MIO 62, MIO 63, MIO 64, MIO 65, MIO 66, MIO 67, MIO 68, MIO 69, MIO 70, MIO 71, MIO 72, MIO 73, MIO 74, MIO 75, MIO 76, MIO 77	<Select>
	PSU__CAN0_LOOP_CAN1__ENABLE	0,1	0
	PSU__DPAUX__PERIPHERAL__ENABLE	0,1	0
	PSU__DPAUX__PERIPHERAL__IO	<Select>, MIO 27 .. 30, MIO 34 .. 37, EMIO	<Select>

Table C-1: User Parameters (Cont'd)

Parameter Description	Parameters	Range	Default Values
ENET Related Parameters	PSU__ENET0__GRP_MDIO__ENABLE	0,1	0
	CONFIG.PSU__ENET0__FIFO__ENABLE	0,1	0
	CONFIG.PSU__ENET0__PTP__ENABLE	0,1	0
	PSU__ENET0__GRP_MDIO__IO	<Select>,EMIO,MIO 76 .. 77	<Select>
	PSU__GEM__TSU__ENABLE	0,1	0
	PSU__GEM__TSU__IO	<Select>,EMIO,MIO 26, MIO 50,MIO 51	<Select>
	PSU__ENET0__PERIPHERAL__ENABLE	0,1	0
	PSU__ENET0__PERIPHERAL__IO	<Select>,EMIO,GT Lane0, MIO 26 .. 37	<Select>
	PSU__ENET1__PERIPHERAL__ENABLE	0,1	0
	PSU__ENET1__PERIPHERAL__IO	<Select>,EMIO,MIO 38 .. 49, GT Lane1	<Select>
	PSU__ENET1__GRP_MDIO__ENABLE	0,1	0
	PSU__ENET1__FIFO__ENABLE	0,1	0
	PSU__ENET1__PTP__ENABLE	0,1	0
	PSU__FPGA_PL0__ENABLE	0,1	1
	PSU__FPGA_PL1__ENABLE	0,1	0
	PSU__FPGA_PL2__ENABLE	0,1	0
	PSU__FPGA_PL3__ENABLE	0,1	0

Table C-1: User Parameters (Cont'd)

Parameter Description	Parameters	Range	Default Values
ENET Related Parameters (Continued)	PSU__ENET1__GRP_MDIO__IO	<Select>,EMIO,MIO 50 .. 51, MIO 76 .. 77	<Select>
	PSU__ENET2__PERIPHERAL__ENABLE	0,1	0
	PSU__ENET2__PERIPHERAL__IO	<Select>,EMIO,GT Lane2, MIO 52 .. 63	<Select>
	PSU__ENET2__GRP_MDIO__ENABLE	0,1	0
	PSU__ENET2__FIFO__ENABLE	0,1	0
	PSU__ENET2__PTP__ENABLE	0,1	0
	PSU__ENET2__GRP_MDIO__IO	<Select>,EMIO,MIO 76 .. 77	<Select>
	PSU__ENET3__PERIPHERAL__ENABLE	0,1	0
	PSU__ENET3__PERIPHERAL__IO	<Select>,EMIO,GT Lane3, MIO 64 .. 75	<Select>
	PSU__ENET3__GRP_MDIO__ENABLE	0,1	0
	PSU__ENET3__FIFO__ENABLE	0,1	0
	PSU__ENET3__PTP__ENABLE	0,1	0
	PSU__ENET3__GRP_MDIO__IO	<Select>,EMIO,MIO 76 .. 77	<Select>
	GPIO Related Parameters	PSU__GPIO_EMIO__PERIPHERAL__ENABLE	0,1
PSU__GPIO_EMIO__PERIPHERAL__IO		<Select>	<Select>
PSU__GPIO0_MIO__PERIPHERAL__ENABLE		0,1	0
PSU__GPIO0_MIO__IO		<Select>,MIO 0 .. 25	<Select>
PSU__GPIO1_MIO__PERIPHERAL__ENABLE		0,1	0
PSU__GPIO1_MIO__IO		<Select>,MIO 26 .. 51	<Select>
PSU__GPIO2_MIO__PERIPHERAL__ENABLE		0,1	0
PSU__GPIO2_MIO__IO		<Select>,MIO 52 .. 77	<Select>

Table C-1: User Parameters (Cont'd)

Parameter Description	Parameters	Range	Default Values
I2C Related Parameters	PSU_I2C0__PERIPHERAL__ENABLE	0,1	0
	PSU_I2C0__PERIPHERAL__IO	<Select>,EMIO,MIO 2 .. 3, MIO 6 .. 7,MIO 10 .. 11, MIO 14 .. 15,MIO 18 .. 19, MIO 22 .. 23,MIO 26 .. 27, MIO 30 .. 31,MIO 34 .. 35, MIO 38 .. 39,MIO 42 .. 43, MIO 46 .. 47,MIO 50 .. 51, MIO 54 .. 55,MIO 58 .. 59, MIO 62 .. 63,MIO 66 .. 67, MIO 70 .. 71,MIO 74 .. 75	<Select>
	PSU_I2C0__GRP_INT__ENABLE	0,1	0
	PSU_I2C0__GRP_INT__IO	<Select>	<Select>
	PSU_I2C1__PERIPHERAL__ENABLE	0,1	0
I2C Related Parameters (continued)	PSU_I2C1__PERIPHERAL__IO	<Select>,EMIO,MIO 0 .. 1, MIO 4 .. 5,MIO 8 .. 9, MIO 12 .. 13,MIO 16 .. 17, MIO 20 .. 21,MIO 24 .. 25, MIO 28 .. 29, MIO 32 .. 33,MIO 36 .. 37, MIO 40 .. 41,MIO 44 .. 45, MIO 48 .. 49,MIO 52 .. 53, MIO 56 .. 57,MIO 60 .. 61, MIO 64 .. 65,MIO 68 .. 69, MIO 72 .. 73,MIO 76 .. 77	<Select>
	PSU_I2C1__GRP_INT__ENABLE	0,1	0
	PSU_I2C1__GRP_INT__IO	<Select>	<Select>
	PSU_I2C0_LOOP_I2C1__ENABLE	0,1	0
	PSU_TESTSCAN__PERIPHERAL__ENABLE	0,1	0

Table C-1: User Parameters (Cont'd)

Parameter Description	Parameters	Range	Default Values
PCIE Peripheral Enable	PSU__PCIE__PERIPHERAL__ENABLE	0,1	0
	PSU__PCIE__PERIPHERAL__ENDPOINT__ENABLE	0,1	1
	PSU__PCIE__PERIPHERAL__ROOTPORT__ENABLE	0,1	0
	PSU__PCIE__PERIPHERAL__ENDPOINT__IO	<Select>,MIO 29,MIO 30, MIO 31,MIO 33,MIO 34, MIO 35,MIO 36,MIO 37	<Select>
	PSU__PCIE__PERIPHERAL__ROOTPORT__IO	<Select>,MIO 0,MIO 1, MIO 2, MIO 3,MIO 4,MIO 5,MIO 6, MIO 7,MIO 8,MIO 9,MIO 10, MIO 11,MIO 12,MIO 13, MIO 14,MIO 15,MIO 16, MIO 17,MIO 18,MIO 19, MIO 20,MIO 21,MIO 22, MIO 23,MIO 24,MIO 25, MIO 26,MIO 27,MIO 28, MIO 29,MIO 30,MIO 31, MIO 32,MIO 33,MIO 34, MIO 35,MIO 36,MIO 37, MIO 38,MIO 39,MIO 40, MIO 41, MIO 42,MIO 43,MIO 44, MIO 45,MIO 46,MIO 47, MIO 48,MIO 49,MIO 50, MIO 51,MIO 52,MIO 53, MIO 54,MIO 55,MIO 56, MIO 57, MIO 58,MIO 59,MIO 60, MIO 61,MIO 62,MIO 63, MIO 64,MIO 65,MIO 66, MIO 67,MIO 68,MIO 69, MIO 70,MIO 71,MIO 72, MIO 73,MIO 74,MIO 75, MIO 76,MIO 77	<Select>

Table C-1: User Parameters (Cont'd)

Parameter Description	Parameters	Range	Default Values
PCIe Lane Selections	PSU__PCIE__LANE0__ENABLE	0,1	0
	PSU__PCIE__LANE0__IO	<Select>,GT Lane0	<Select>
	PSU__PCIE__LANE1__ENABLE	0,1	0
	PSU__PCIE__LANE1__IO	<Select>,GT Lane1	<Select>
	PSU__PCIE__LANE2__ENABLE	0,1	0
	PSU__PCIE__LANE2__IO	<Select>,GT Lane2	<Select>
	PSU__PCIE__LANE3__ENABLE	0,1	0
	PSU__PCIE__LANE3__IO	<Select>,GT Lane3	<Select>
	PSU__GT__LINK_SPEED	<Select>,RBR,HBR,HBR2	<Select>
	PSU__GT__VLT_SWNG_LVL_4	NA	
PSU__GT__PRE_EMPH_LVL_4	NA		
USB Related Parameters	PSU__USB0__REF_CLK_SEL	<Select>,Ref Clk0,Ref Clk1,Ref Clk2,Ref Clk3	<Select>
	PSU__USB0__REF_CLK_FREQ	<Select>,26,52,100	<Select>
	PSU__USB1__REF_CLK_SEL	<Select>,Ref Clk0,Ref Clk1,Ref Clk2,Ref Clk3	<Select>
	PSU__USB1__REF_CLK_FREQ	<Select>,26,52,100	<Select>
GEM Ref CLK	PSU__GEM0__REF_CLK_SEL	<Select>,Ref Clk0,Ref Clk1,Ref Clk2,Ref Clk3	<Select>
	PSU__GEM0__REF_CLK_FREQ	<Select>,125	<Select>
	PSU__GEM1__REF_CLK_SEL	<Select>,Ref Clk0,Ref Clk1,Ref Clk2,Ref Clk3	<Select>
	PSU__GEM1__REF_CLK_FREQ	<Select>,125	<Select>
	PSU__GEM2__REF_CLK_SEL	<Select>,Ref Clk0,Ref Clk1,Ref Clk2,Ref Clk3	<Select>
	PSU__GEM2__REF_CLK_FREQ	<Select>,125	<Select>
	PSU__GEM3__REF_CLK_SEL	<Select>,Ref Clk0,Ref Clk1,Ref Clk2,Ref Clk3	<Select>
	PSU__GEM3__REF_CLK_FREQ	<Select>,125	<Select>
DP Ref Clk	PSU__DP__REF_CLK_SEL	<Select>,Ref Clk0,Ref Clk1,Ref Clk2,Ref Clk3	<Select>
	PSU__DP__REF_CLK_FREQ	<Select>,27,108,135	<Select>

Table C-1: User Parameters (Cont'd)

Parameter Description	Parameters	Range	Default Values
SATA Ref Clk	PSU__SATA__REF_CLK_SEL	<Select>,Ref Clk0,Ref Clk1,Ref Clk2,Ref Clk3	<Select>
	PSU__SATA__REF_CLK_FREQ	<Select>,150,125	<Select>
PCIE Ref Clk	PSU__PCIE__REF_CLK_SEL	<Select>,Ref Clk0,Ref Clk1,Ref Clk2,Ref Clk3	<Select>
	PSU__PCIE__REF_CLK_FREQ	<Select>,100	<Select>
DP Lane Selection	PSU__DP__LANE_SEL	<Select>,Dual Higher,Dual Lower,Single Higher,Single Lower	<Select>

Table C-1: User Parameters (Cont'd)

Parameter Description	Parameters	Range	Default Values
PCIe Related Parameters	PSU__PCIE__DEVICE_PORT_TYPE	<Select>,Root Port, Endpoint Device	<Select>
	PSU__PCIE__MAXIMUM_LINK_WIDTH	<Select>,x1,x2,x4	<Select>
	PSU__PCIE__LINK_SPEED	<Select>,2.5 Gb/s,5.0 Gb/s	<Select>
	PSU__PCIE__INTERFACE_WIDTH	<Select>,64bit	<Select>
	PSU__PCIE__BAR0_ENABLE	0,1	0
	PSU__PCIE__BAR0_TYPE	<Select>,Memory,IO	<Select>
	PSU__PCIE__BAR0_SCALE	<Select>,Bytes,Kilobytes, Megabytes,Gigabytes,Tera bytes ,Petabytes,Exabytes	<Select>
	PSU__PCIE__BAR0_64BIT	0,1	0
	PSU__PCIE__BAR0_SIZE	<Select>,1,2,4,8,16,32,64, 128, 256,512	<Select>
	PSU__PCIE__BAR0_VAL	NA	
	PSU__PCIE__BAR0_PREFETCHABLE	0,1	0
	PSU__PCIE__BAR1_ENABLE	0,1	0
	PSU__PCIE__BAR1_TYPE	<Select>,Memory,IO	<Select>
	PSU__PCIE__BAR1_SCALE	<Select>,Bytes,Kilobytes, Megabytes,Gigabytes,Tera bytes, Petabytes,Exabytes	<Select>
	PSU__PCIE__BAR1_64BIT	0,1	0
	PSU__PCIE__BAR1_SIZE	<Select>,1,2,4,8,16,32,64, 128, 256,512	<Select>
	PSU__PCIE__BAR1_VAL	NA	
	PSU__PCIE__BAR1_PREFETCHABLE	0,1	0
	PSU__PCIE__BAR2_ENABLE	0,1	0
	PSU__PCIE__BAR2_TYPE	<Select>,Memory	<Select>
	PSU__PCIE__BAR2_SCALE	<Select>,Bytes,Kilobytes, Megabytes,Gigabytes,Tera bytes, Petabytes,Exabytes	<Select>
	PSU__PCIE__BAR2_64BIT	0,1	0
	PSU__PCIE__BAR2_SIZE	<Select>,1,2,4,8,16,32,64, 128, 256,512	<Select>
PSU__PCIE__BAR2_VAL	NA		

Table C-1: User Parameters (Cont'd)

Parameter Description	Parameters	Range	Default Values
PCIE Related Parameters (continued)	PSU__PCIE__BAR3_TYPE	<Select>,Memory	<Select>
	PSU__PCIE__BAR3_SCALE	<Select>,Bytes,Kilobytes, Megabytes,Gigabytes,Tera bytes, Petabytes,Exabytes	<Select>
	PSU__PCIE__BAR3_64BIT	0,1	0
	PSU__PCIE__BAR3_SIZE	<Select>,1,2,4,8,16,32,64, 128, 256,512	<Select>
	PSU__PCIE__BAR3_VAL	NA	
	PSU__PCIE__BAR3_PREFETCHABLE	0,1	0
	PSU__PCIE__BAR4_ENABLE	0,1	0
	PSU__PCIE__BAR4_TYPE	<Select>,Memory	<Select>
	PSU__PCIE__BAR4_SCALE	<Select>,Bytes,Kilobytes, Megabytes,Gigabytes,Tera bytes, Petabytes,Exabytes	<Select>
	PSU__PCIE__BAR4_64BIT	0,1	0
	PSU__PCIE__BAR4_SIZE	<Select>,1,2,4,8,16,32,64, 128, 256,512	<Select>
	PSU__PCIE__BAR4_VAL	NA	
	PSU__PCIE__BAR4_PREFETCHABLE	0,1	0
	PSU__PCIE__BAR5_ENABLE	0,1	0
	PSU__PCIE__BAR5_TYPE	<Select>,Memory	<Select>
	PSU__PCIE__BAR5_SCALE	<Select>,Bytes,Kilobytes, Megabytes,Gigabytes	<Select>
	PSU__PCIE__BAR5_64BIT	0,1	0
	PSU__PCIE__BAR5_SIZE	<Select>,1,2,4,8,16,32,64, 128, 256,512	<Select>
	PSU__PCIE__BAR5_VAL	NA	
	PSU__PCIE__BAR5_PREFETCHABLE	0,1	0
	PSU__PCIE__EROM_ENABLE	0,1	0
	PSU__PCIE__EROM_SCALE	<Select>,Kilobytes,Mega bytes, Gigabytes	<Select>
	PSU__PCIE__EROM_SIZE	<Select>,2,4,8,16,32,64,1 28,256, 512	<Select>
PSU__PCIE__EROM_VAL	NA		

Table C-1: User Parameters (Cont'd)

Parameter Description	Parameters	Range	Default Values
PCIE Related Parameters (continued)	PSU__PCIE__VENDOR_ID	NA	
	PSU__PCIE__DEVICE_ID	NA	
	PSU__PCIE__REVISION_ID	NA	
	PSU__PCIE__SUBSYSTEM_VENDOR_ID	NA	
	PSU__PCIE__SUBSYSTEM_ID	NA	
	PSU__PCIE__BASE_CLASS_MENU	See Note ⁽¹⁾ for values	<Select>
	PSU__PCIE__USE_CLASS_CODE_LOOKUP_ASSISTANT	<Select>,0,1	<Select>
	PSU__PCIE__SUB_CLASS_INTERFACE_MENU	<Select>, Computer telephony device, Audio device, Video device, Other multimedia device	<Select>
	PSU__PCIE__CLASS_CODE_BASE	NA	
	PSU__PCIE__CLASS_CODE_SUB	NA	
	PSU__PCIE__CLASS_CODE_INTERFACE	NA	
	PSU__PCIE__CLASS_CODE_VALUE	NA	
	PSU__PCIE__AER_CAPABILITY	0,1	0
	PSU__PCIE__CORRECTABLE_INT_ERR	0,1	0
	PSU__PCIE__HEADER_LOG_OVERFLOW	0,1	0
	PSU__PCIE__RECEIVER_ERR	0,1	0
	PSU__PCIE__SURPRISE_DOWN	0,1	0
	PSU__PCIE__FLOW_CONTROL_ERR	0,1	0
PSU__PCIE__COMPLTION_TIMEOUT	0,1	0	

Table C-1: User Parameters (Cont'd)

Parameter Description	Parameters	Range	Default Values
PCIE Related Parameters (continued)	PSU__PCIE__COMPLETER_ABORT	0,1	0
	PSU__PCIE__RECEIVER_OVERFLOW	0,1	0
	PSU__PCIE__ECRC_ERR	0,1	0
	PSU__PCIE__ACS_VIOLAION	NA	NA
	PSU__PCIE__UNCORRECTABL_INT_ERR	0,1	0
	PSU__PCIE__MC_BLOCKED_TLP	0,1	0
	PSU__PCIE__ATOMICOP_EGRESS_BLOCKED	0,1	0
	PSU__PCIE__TLP_PREFIX_BLOCKED	0,1	0
	PSU__PCIE__FLOW_CONTROL_PROTOCOL_ERR	0,1	0
	PSU__PCIE__ACS_VIOLATION	0,1	0
	PSU__PCIE__MULTIHEADER	0,1	0
	PSU__PCIE__ECRC_CHECK	0,1	0
	PSU__PCIE__ECRC_GEN	0,1	0
	PSU__PCIE__PERM_ROOT_ERR_UPDATE	0,1	0
	PSU__PCIE__CRS_SW_VISIBILITY	0,1	0
	PSU__PCIE__INTX_GENERATION	0,1	0
	PSU__PCIE__INTX_PIN	<Select>,INTA	<Select>
	PSU__PCIE__MSI_CAPABILITY	0,1	0
	PSU__PCIE__MSI_64BIT_ADDR_CAPABLE	0,1	0
	PSU__PCIE__MSI_MULTIPLE_MSG_CAPABLE	<Select>,1 Vector,2 Vector,4 Vector,8 Vector,16 Vector,32 Vector	<Select>
	PSU__PCIE__MSIX_CAPABILITY	0,1	0
	PSU__PCIE__MSIX_TABLE_SIZE	NA	0
	PSU__PCIE__MSIX_TABLE_OFFSET	NA	0
	PSU__PCIE__MSIX_BAR_INDICATOR	NA	
	PSU__PCIE__MSIX_PBA_OFFSET	NA	0
	PSU__PCIE__MSIX_PBA_BAR_INDICATOR	NA	
	PSU__PCIE__BRIDGE_BAR_INDICATOR	<Select>,BAR 0,BAR 1,BAR 2,BAR 3,BAR 4,BAR 5	<Select>
PSU_IMPORT_BOARD_PRESET	NA		

Table C-1: User Parameters (Cont'd)

Parameter Description	Parameters	Range	Default Values
Isolation & protection related parameters	PSU__PROTECTION__SUBSYSTEMS		PMU Firmware: PU
	PSU__PROTECTION__MASTERS_TZ		None
	PSU__PROTECTION__MASTERS		See Table C-2 for values
	PSU__PROTECTION__DDR_SEGMENTS		None
	PSU__PROTECTION__OCM_SEGMENTS		None
	PSU__PROTECTION__LPD_SEGMENTS		None
	PSU__PROTECTION__FPD_SEGMENTS		None
	PSU__PROTECTION__DEBUG		1
	PSU__PROTECTION__SLAVES		See Table C-3 for values
	PSU__PROTECTION__PRESUBSYSTEMS		None
	PSU__PROTECTION__ENABLE		False
	PSU__PROTECTION__LOCK_UNUSED_SEGMENTS		0
Internal Parameter	PSU__EP__IP	0,1	0
	PSU__ACTUAL__IP	0,1	1
Nand Related Parameters	PSU__NAND__PERIPHERAL__IO	<Select>,MIO 13 .. 25	<Select>
	PSU__NAND__PERIPHERAL__ENABLE	0,1	0
	PSU__NAND__READY__BUSY__ENABLE	0,1	0
	PSU__NAND__READY__BUSY__IO	<Select>,MIO 10 .. 11,MIO 27 .. 28	<Select>
	PSU__NAND__CHIP__ENABLE__ENABLE	0,1	0
	PSU__NAND__CHIP__ENABLE__IO	<Select>,MIO 9,MIO 26	<Select>
	PSU__NAND__DATA__STROBE__ENABLE	0,1	0
	PSU__NAND__DATA__STROBE__IO	<Select>,MIO 12,MIO 32	<Select>
	PSU__PJTAG__PERIPHERAL__ENABLE	0,1	0
	PSU__PJTAG__PERIPHERAL__IO	<Select>,MIO 0 .. 3, MIO 12 .. 15,MIO 26 .. 29, MIO 38 .. 41,MIO 52 .. 55, MIO 58 .. 61	<Select>

Table C-1: User Parameters (Cont'd)

Parameter Description	Parameters	Range	Default Values
PMU related Parameters	PSU__PMU__PERIPHERAL__ENABLE	0,1	0
	PSU__PMU__PERIPHERAL__IO	<Select>	<Select>
	PSU__PMU__EMIO_GPI__ENABLE	0,1	0
	PSU__PMU__EMIO_GPO__ENABLE	0,1	0
	PSU__PMU__GPIO__ENABLE	0,1	0
	PSU__PMU__GPIO1__ENABLE	0,1	0
	PSU__PMU__GPIO2__ENABLE	0,1	0
	PSU__PMU__GPIO3__ENABLE	0,1	0
	PSU__PMU__GPIO4__ENABLE	0,1	0
	PSU__PMU__GPIO5__ENABLE	0,1	0
	PSU__PMU__GPO0__ENABLE	0,1	0
	PSU__PMU__GPO1__ENABLE	0,1	0
	PSU__PMU__GPO2__ENABLE	0,1	0
	PSU__PMU__GPO3__ENABLE	0,1	0
	PSU__PMU__GPO4__ENABLE	0,1	0
	PSU__PMU__GPO5__ENABLE	0,1	0
	PSU__PMU__GPIO__IO	<Select>,MIO 26	<Select>
	PSU__PMU__GPIO1__IO	<Select>,MIO 27	<Select>
	PSU__PMU__GPIO2__IO	<Select>,MIO 28	<Select>
	PSU__PMU__GPIO3__IO	<Select>,MIO 29	<Select>
	PSU__PMU__GPIO4__IO	<Select>,MIO 30	<Select>
	PSU__PMU__GPIO5__IO	<Select>,MIO 31	<Select>
	PSU__PMU__GPO0__IO	<Select>,MIO 32	<Select>
	PSU__PMU__GPO1__IO	<Select>,MIO 33	<Select>
	PSU__PMU__GPO2__IO	<Select>,MIO 34	<Select>
	PSU__PMU__GPO3__IO	<Select>,MIO 35	<Select>
PSU__PMU__GPO4__IO	<Select>,MIO 36	<Select>	
PSU__PMU__GPO5__IO	<Select>,MIO 37	<Select>	
	CONFIG.PSU__PMU__AIBACK__ENABLE	0,1	0
	CONFIG.PSU__PMU__PLERROR__ENABLE	0,1	0
CSU	PSU__CSU__PERIPHERAL__ENABLE	0,1	0
	PSU__CSU__PERIPHERAL__IO	<Select>,MIO 18,MIO 19, MIO 20,MIO 21,MIO 22, MIO 23,MIO 24,MIO 25, MIO 26,MIO 31,MIO 32,MIO 33	<Select>

Table C-1: User Parameters (Cont'd)

Parameter Description	Parameters	Range	Default Values
QSPI Related Parameters	PSU__QSPI__PERIPHERAL__ENABLE	0,1	0
	PSU__QSPI__PERIPHERAL__IO	<Select>,MIO 0 .. 5,MIO 0 .. 7, MIO 0 .. 12	<Select>
	PSU__QSPI__PERIPHERAL__MODE	<Select>,Single,Dual Stacked, Dual Parallel	<Select>
	PSU__QSPI__PERIPHERAL__DATA_MODE	<Select>,x1,x2,x4	<Select>
	PSU__QSPI__GRP_FBCLK__ENABLE	0,1	0
	PSU__QSPI__GRP_FBCLK__IO	<Select>,MIO 6	<Select>

Table C-1: User Parameters (Cont'd)

Parameter Description	Parameters	Range	Default Values
SD Related Parameters	PSU__SD0__PERIPHERAL__ENABLE	0,1	0
	PSU__SD0__PERIPHERAL__IO	<Select>,EMIO, MIO 13 .. 16 21 22, MIO 38 .. 44,MIO 64 .. 70, MIO 13 .. 22,MIO 38 .. 48, MIO 64 .. 74	<Select>
	PSU__SD0__GRP_CD__ENABLE	0,1	0
	PSU__SD0__GRP_CD__IO	<Select>,EMIO,MIO 24, MIO 39,MIO 65	<Select>
	PSU__SD0__GRP_POW__ENABLE	0,1	0
	PSU__SD0__GRP_POW__IO	<Select>,EMIO,MIO 23, MIO 49,MIO 75	<Select>
	PSU__SD0__GRP_WP__ENABLE	0,1	0
	PSU__SD0__GRP_WP__IO	<Select>,EMIO,MIO 25, MIO 50,MIO 76	<Select>
	PSU__SD0__SLOT_TYPE	<Select>,SD 2.0,SD 3.0,eMMC	<Select>
	PSU__SD0__RESET__ENABLE	0,1	0
	PSU__SD0__DATA_TRANSFER_MODE	<Select>,4Bit,8Bit	<Select>
	PSU__SD1__PERIPHERAL__ENABLE	0,1	0
	PSU__SD1__PERIPHERAL__IO	<Select>,EMIO,MIO 39 .. 51, MIO 46 .. 51,MIO 71 .. 76	<Select>
	PSU__SD1__GRP_CD__ENABLE	0,1	0
	PSU__SD1__GRP_CD__IO	<Select>,MIO 45,MIO 77,EMIO	<Select>
	PSU__SD1__GRP_POW__ENABLE	0,1	0
	PSU__SD1__GRP_POW__IO	<Select>,MIO 43,MIO 70,EMIO	<Select>
	PSU__SD1__GRP_WP__ENABLE	0,1	0
	PSU__SD1__GRP_WP__IO	<Select>,MIO 44,MIO 69,EMIO	<Select>
	PSU__SD1__SLOT_TYPE	<Select>,SD 2.0,SD 3.0,eMMC	<Select>
	PSU__SD1__RESET__ENABLE	0,1	0
PSU__SD1__DATA_TRANSFER_MODE	<Select>,4Bit,8Bit	<Select>	
Internal Parameter	PSU__DEVICE_TYPE	EG,CG,EV	EG

Table C-1: User Parameters (Cont'd)

Parameter Description	Parameters	Range	Default Values
SPI Related Parameters	PSU__SPI0__PERIPHERAL__ENABLE	0,1	0
	PSU__SPI0__PERIPHERAL__IO	<Select>,EMIO,MIO 0 .. 5, MIO 12 .. 17,MIO 26 .. 31, MIO 38 .. 43,MIO 52 .. 57, MIO 64 .. 69	<Select>
	PSU__SPI0__GRP_SS0__ENABLE	0,1	0
	PSU__SPI0__GRP_SS0__IO	<Select>,MIO 3,MIO 15, MIO 29,MIO 41,MIO 55, MIO 67,EMIO	<Select>
	PSU__SPI0__GRP_SS1__ENABLE	0,1	0
	PSU__SPI0__GRP_SS1__IO	<Select>,MIO 2,MIO 14, MIO 28,MIO 40,MIO 54, MIO 66,EMIO	<Select>
	PSU__SPI0__GRP_SS2__ENABLE	0,1	0
	PSU__SPI0__GRP_SS2__IO	<Select>,MIO 1,MIO 13, MIO 27,MIO 39,MIO 53, MIO 65,EMIO	<Select>
	PSU__SPI1__PERIPHERAL__ENABLE	0,1	0
	PSU__SPI1__PERIPHERAL__IO	<Select>,EMIO,MIO 6 .. 11, MIO 18 .. 23, MIO 32 .. 37,MIO 44 .. 49, MIO 58 .. 63,MIO 70 .. 75	<Select>
	PSU__SPI1__GRP_SS0__ENABLE	0,1	0
	PSU__SPI1__GRP_SS0__IO	<Select>,MIO 9,MIO 21, MIO 35,MIO 47,MIO 61, MIO 73,EMIO	<Select>
	PSU__SPI1__GRP_SS1__ENABLE	0,1	0
	PSU__SPI1__GRP_SS1__IO	<Select>,MIO 8,MIO 20, MIO 34,MIO 46,MIO 60, MIO 72,EMIO	<Select>
	PSU__SPI1__GRP_SS2__ENABLE	0,1	0
	PSU__SPI1__GRP_SS2__IO	<Select>,MIO 7,MIO 19, MIO 33,MIO 45,MIO 59, MIO 71,EMIO	<Select>
	PSU__SPI0__LOOP_SPI1__ENABLE	0,1	0

Table C-1: User Parameters (Cont'd)

Parameter Description	Parameters	Range	Default Values
SWDT Related parameters	PSU__SWDT0__PERIPHERAL__ENABLE	0,1	0
	PSU__SWDT0__CLOCK__ENABLE	0,1	0
	PSU__SWDT0__RESET__ENABLE	0,1	0
	PSU__SWDT0__PERIPHERAL__IO	NA	NA
	PSU__SWDT0__CLOCK__IO	<Select>,EMIO,MIO 6,MIO 10, MIO 18,MIO 22,MIO 30, MIO 34,MIO 42,MIO 46, MIO 50,MIO 62,MIO 66, MIO 70,MIO 74	<Select>
	PSU__SWDT0__RESET__IO	<Select>,EMIO,MIO 7,MIO 11, MIO 19,MIO 23,MIO 31, MIO 35,MIO 43,MIO 47, MIO 51,MIO 63,MIO 67, MIO 71,MIO 75	<Select>
	PSU__SWDT1__PERIPHERAL__ENABLE	0,1	0
	PSU__SWDT1__CLOCK__ENABLE	0,1	0
	PSU__SWDT1__RESET__ENABLE	0,1	0
	PSU__SWDT1__PERIPHERAL__IO	NA	NA
	PSU__SWDT1__CLOCK__IO	<Select>,EMIO,MIO 4,MIO 8, MIO 16,MIO 20,MIO 24, MIO 32,MIO 36,MIO 44, MIO 48,MIO 56,MIO 64, MIO 68,MIO 72	<Select>
	PSU__SWDT1__RESET__IO	<Select>,EMIO,MIO 5,MIO 9, MIO 17,MIO 21,MIO 25, MIO 33,MIO 37,MIO 45, MIO 49,MIO 57,MIO 65, MIO 69,MIO 73	<Select>
UART Baud rate	PSU__UART0__BAUD_RATE	<Select>,110,300,1200,2400,4800,9600,19200,38400,57600,115200, 128000,230400,460800,921600	<Select>

Table C-1: User Parameters (Cont'd)

Parameter Description	Parameters	Range	Default Values
Trace Related Parameters	PSU__TRACE__PERIPHERAL__ENABLE	0,1	0
	PSU__TRACE__PERIPHERAL__IO	<Select>,MIO 0 .. 17, MIO 26 .. 43,MIO 52 .. 69,EMIO	<Select>
	PSU__TRACE__WIDTH	<Select> ,2Bit,4Bit,8Bit,16 Bit,32Bit	<Select>
	PSU__TRACE__INTERNAL_WIDTH	2,4,8,16,32	32

Table C-1: User Parameters (Cont'd)

Parameter Description	Parameters	Range	Default Values
TTC Related Parameters	PSU__TTC0__PERIPHERAL__ENABLE	0,1	0
	PSU__TTC0__CLOCK__ENABLE	0,1	0
	PSU__TTC0__WAVEOUT__ENABLE	0,1	0
	PSU__TTC0__CLOCK__IO	<Select>,EMIO,MIO 6,MIO 14, MIO 22,MIO 30,MIO 38, MIO 46,MIO 54,MIO 62,MIO 70	<Select>
	PSU__TTC0__WAVEOUT__IO	<Select>,EMIO,MIO 7,MIO 15, MIO 23,MIO 31,MIO 39, MIO 47,MIO 55,MIO 63,MIO 71	<Select>
	PSU__TTC0__PERIPHERAL__IO	NA	NA
	PSU__TTC1__PERIPHERAL__ENABLE	0,1	0
	PSU__TTC1__PERIPHERAL__IO	NA	NA
UART Baud rate	PSU__UART1__BAUD_RATE	<Select>,110,300,1200,2400,4800,9600,19200,38400,57600,115200,128000,230400,460800,921600	<Select>

Table C-1: User Parameters (Cont'd)

Parameter Description	Parameters	Range	Default Values
TTC Related Parameters	PSU__TTC1__CLOCK__ENABLE	0,1	0
	PSU__TTC1__WAVEOUT__ENABLE	0,1	0
	PSU__TTC1__CLOCK__IO	<Select>,EMIO,MIO 4,MIO 12, MIO 20,MIO 28,MIO 36,MIO 44,MIO 52,MIO 60,MIO 68	<Select>
	PSU__TTC1__WAVEOUT__IO	<Select>,EMIO,MIO 5,MIO 13, MIO 21,MIO 29,MIO 37, MIO 45,MIO 53,MIO 61,MIO 69	<Select>
	PSU__TTC2__PERIPHERAL__ENABLE	0,1	0
	PSU__TTC2__PERIPHERAL__IO	NA	NA
	PSU__TTC2__CLOCK__ENABLE	0,1	0
	PSU__TTC2__WAVEOUT__ENABLE	0,1	0
	PSU__TTC2__CLOCK__IO	<Select>,EMIO,MIO 2,MIO 10, MIO 18,MIO 26,MIO 34, MIO 42,MIO 50,MIO 58,MIO 66	<Select>
	PSU__TTC2__WAVEOUT__IO	<Select>,EMIO,MIO 3,MIO 11, MIO 19,MIO 27,MIO 35, MIO 43,MIO 51,MIO 59,MIO 67	<Select>
	PSU__TTC3__PERIPHERAL__ENABLE	0,1	0
	PSU__TTC3__PERIPHERAL__IO	NA	NA
	PSU__TTC3__CLOCK__ENABLE	0,1	0
	PSU__TTC3__WAVEOUT__ENABLE	0,1	0
TTC Related Parameters (continued)	PSU__TTC3__CLOCK__IO	<Select>,EMIO,MIO 0,MIO 8,MIO 16,MIO 24,MIO 32,MIO 40,MIO 48,MIO 56,MIO 64	<Select>
	PSU__TTC3__WAVEOUT__IO	<Select>,EMIO,MIO 1,MIO 9,MIO 17,MIO 25,MIO 33,MIO 41,MIO 49,MIO 57,MIO 65	<Select>

Table C-1: User Parameters (Cont'd)

Parameter Description	Parameters	Range	Default Values
DDR Related Parameters	PSU__DDRC__AL		0
	PSU__DDRC__BANK_ADDR_COUNT		3
	PSU__DDRC__BUS_WIDTH	32 Bit,64 Bit	64 Bit
	PSU__DDRC__CL	NA	7
	PSU__DDRC__CLOCK_STOP_EN	0,1	0
	PSU__DDRC__COL_ADDR_COUNT		10
	PSU__DDRC__RANK_ADDR_COUNT		0
	PSU__DDRC__CWL	NA	7
	PSU__DDRC__BG_ADDR_COUNT	1.000000,2.000000	NA
	PSU__DDRC__DEVICE_CAPACITY	512 MBits,1024 MBits,2048 MBits,4096 MBits,8192 MBits	2048 MBits
	PSU__DDRC__DRAM_WIDTH	8 Bits,16 Bits	8 Bits
	PSU__DDRC__ECC	Disabled,Enabled	Disabled
	PSU__DDRC__ECC_SCRUB	0,1	0
	PSU__DDRC__ENABLE	0,1	1
	PSU__DDRC__FREQ_MHZ	-2,-1	1
	PSU__DDRC__HIGH_TEMP	<Select>	<Select>
	PSU__DDRC__MEMORY_TYPE	LPDDR 3,DDR 3, DDR 3 (Low Voltage),DDR 4, LPDDR 4	DDR 4
	PSU__DDRC__PARTNO	<Select>	<Select>
	PSU__DDRC__ROW_ADDR_COUNT	-2,-1	15
	PSU__DDRC__SPEED_BIN	DDR3_800D,DDR3_800E, DDR3_1066E,DDR3_1066F , DDR3_1066G,DDR3_1333F , DDR3_1333G,DDR3_1333 H, DDR3_1333J,DDR3_1600G , DDR3_1600H,DDR3_1600J , DDR3_1600K,DDR3_1866J , DDR3_1866K,DDR3_1866L , DDR3_1866M,DDR3_2133 N	DDR4_1600J
PSU__DDRC__T_FAW	-0.1,100	35	

Table C-1: User Parameters (Cont'd)

Parameter Description	Parameters	Range	Default Values
DDR Related Parameters (continued)	PSU__DDRC__T_RCD	-2,-1	10
	PSU__DDRC__T_RP	-0.1,100	10
	PSU__DDRC__TRAIN_DATA_EYE	0,1	1
	PSU__DDRC__TRAIN_READ_GATE	0,1	1
	PSU__DDRC__TRAIN_WRITE_LEVEL	0,1	1
	PSU__DDRC__VREF	0,1	1
	PSU__DDRC__VIDEO_BUFFER_SIZE	0,1,2,4,8,16,32	0
	PSU__DDRC__BRC_MAPPING	ROW_BANK_COL,BANK_ROW_COL	ROW_BANK_COL
	PSU__DDRC__DIMM_ADDR_MIRROR	0,1	0
	PSU__DDRC__STATIC_RD_MODE	0,1	0
	PSU__DDRC__DDR4_MAXPWR_SAVING_EN	0,1	NA
	PSU__DDRC__PWR_DOWN_EN	0,1	0
	PSU__DDRC__DEEP_PWR_DOWN_EN	<Select>,0,1	<Select>
	PSU__DDRC__PLL_BYPASS	0,1	0
	PSU__DDRC__DDR4_T_REF_MODE	0,1	NA
	PSU__DDRC__DDR4_T_REF_RANGE	Normal (0-85),High (95 Max)	NA
	PSU__DDRC__PHY_DBI_MODE	0,1	0
	PSU__DDRC__DM_DBI	NO_DM_NO_DBI, NO_DM_DBI_RD_WR,NO_DM_DBI_RD, NO_DM_DBI_WR,DM_DBI_RD_WR,DM_DBI_RD,DM_DBI_WR,DM_NO_DBI	DM_NO_DBI
	PSU__DDRC__COMPONENTS	Components,UDIMM,RDIMM	Components
	PSU__DDRC__PARITY_ENABLE	0,1	NA
PSU__DDRC__DDR4_CAL_MODE_ENABLE	0,1	NA	
PSU__DDRC__DDR4_CRC_CONTROL	0,1	NA	
PSU__DDRC__FGRM	1X,2X,4X	1X	
PSU__DDRC__VENDOR_PART	OTHERS,SAMSUNG,HYNIX	OTHERS	

Table C-1: User Parameters (Cont'd)

Parameter Description	Parameters	Range	Default Values
	PSU_DDRC__SB_TARGET	5-5-5,6-6-6,7-7-7,8-8-8,9-9-9,10-10-10,11-11-11,12-12-12,13-13-13,14-14-14,15-15-15,16-16-16,18-18-18,NA	10-10-10
DDR Related Parameters (continued)	PSU_DDRC__LP_ASR	manual normal, manual reduced, manual extended, auto self refresh	manual normal
	PSU_DDRC__DDR4_ADDR_MAPPING	0,1	NA
	PSU_DDRC__SELF_REF_ABORT	0,1	0
	PSU_DDRC__DERATE_INT_D	<Select>	<Select>
	PSU_DDRC__ADDR_MIRROR	0,NA,1	NA
	PSU_DDRC__EN_2ND_CLK	0,1	0
	PSU_DDRC__PER_BANK_REFRESH	0,1	0
	PSU_DDR_RAM_HIGHADDR	NA	0x1FFFFFFF
Full Power Domain ON	PSU_FP__POWER_ON	0,1	1
PL Power ON	PSU_PL__POWER_ON	0,1	1
OCM Bank Power ON	PSU__OCM_BANK0__POWER_ON	0,1	1
	PSU__OCM_BANK1__POWER_ON	0,1	1
	PSU__OCM_BANK2__POWER_ON	0,1	1
	PSU__OCM_BANK3__POWER_ON	0,1	1
TCM Power On	PSU__TCM0A__POWER_ON	0,1	1
	PSU__TCM0B__POWER_ON	0,1	1
	PSU__TCM1A__POWER_ON	0,1	1
	PSU__TCM1B__POWER_ON	0,1	1
RPU Power ON	PSU__RPU__POWER_ON	0,1	1
	PSU__L2_BANK0__POWER_ON	0,1	1
	PSU__GPU_PP0__POWER_ON	0,1	1
	PSU__GPU_PP1__POWER_ON	0,1	1
	PSU__ACPU0__POWER_ON	0,1	1
	PSU__ACPU1__POWER_ON	0,1	1
	PSU__ACPU2__POWER_ON	0,1	1
	PSU__ACPU3__POWER_ON	0,1	1

Table C-1: User Parameters (Cont'd)

Parameter Description	Parameters	Range	Default Values
UART Related Parameters	PSU__UART0__PERIPHERAL__ENABLE	0,1	0
	PSU__UART0__PERIPHERAL__IO	<Select>,EMIO,MIO 2 .. 3, MIO 6 .. 7,MIO 10 .. 11, MIO 14 .. 15,MIO 18 .. 19, MIO 22 .. 23,MIO 26 .. 27, MIO 30 .. 31,MIO 34 .. 35, MIO 38 .. 39,MIO 42 .. 43, MIO 46 .. 47,MIO 50 .. 51, MIO 54 .. 55,MIO 58 .. 59, MIO 62 .. 63,MIO 66 .. 67, MIO 70 .. 71,MIO 74 .. 75	<Select>
	PSU__UART0__MODEM__ENABLE	0,1	0
	PSU__UART1__PERIPHERAL__ENABLE	0,1	0
UART Related Parameters (continued)	PSU__UART1__PERIPHERAL__IO	<Select>,EMIO,MIO 0 .. 1, MIO 4 .. 5,MIO 8 .. 9, MIO 12 .. 13,MIO 16 .. 17, MIO 20 .. 21,MIO 24 .. 25, MIO 28 .. 29,MIO 32 .. 33, MIO 36 .. 37,MIO 40 .. 41, MIO 44 .. 45,MIO 48 .. 49, MIO 52 .. 53,MIO 56 .. 57, MIO 60 .. 61,MIO 64 .. 65, MIO 68 .. 69,MIO 72 .. 73	<Select>
	PSU__UART1__MODEM__ENABLE	0,1	0
	PSU__UART0__LOOP__UART1__ENABLE	0,1	0
USB Related Parameters	PSU__USB0__PERIPHERAL__ENABLE	0,1	0
	PSU__USB0__PERIPHERAL__IO	<Select>,MIO 52 .. 63	<Select>
	PSU__USB1__PERIPHERAL__ENABLE	0,1	0
	PSU__USB1__PERIPHERAL__IO	<Select>,MIO 64 .. 75	<Select>
	PSU__USB3_0__PERIPHERAL__ENABLE	0,1	0
	PSU__USB3_0__PERIPHERAL__IO	<Select>,GT Lane0,GT Lane1, GT Lane2	<Select>
	PSU__USB3_1__PERIPHERAL__ENABLE	0,1	0
	PSU__USB3_1__PERIPHERAL__IO	<Select>,GT Lane3	<Select>
	PSU__USB3_0__EMIO__ENABLE	0,1	0
	PSU__USB2_0__EMIO__ENABLE	0,1	0
	PSU__USB3_1__EMIO__ENABLE	0,1	0
	PSU__USB2_1__EMIO__ENABLE	0,1	0

Table C-1: User Parameters (Cont'd)

Parameter Description	Parameters	Range	Default Values
PS PL Interface related Parameters	PSU__USE__M_AXI_GP0	0,1	0
	PSU__MAXIGP0__DATA_WIDTH	128,64,32	128
	PSU__USE__M_AXI_GP1	0,1	0
	PSU__MAXIGP1__DATA_WIDTH	128,64,32	128
	PSU__USE__M_AXI_GP2	0,1	1
	PSU__MAXIGP2__DATA_WIDTH	128,64,32	128
	PSU__USE__S_AXI_ACP	0,1	0
	PSU__USE__S_AXI_GP0	0,1	0
	PSU__USE_DIFF_RW_CLK_GP0	0,1	0
	PSU__SAXIGP0__DATA_WIDTH	128,64,32	128
	PSU__USE__S_AXI_GP1	0,1	0
	PSU__USE_DIFF_RW_CLK_GP1	0,1	0
	PSU__SAXIGP1__DATA_WIDTH	128,64,32	128
PS PL Interface related Parameters (continued)	PSU__USE__S_AXI_GP2	0,1	0
	PSU__USE_DIFF_RW_CLK_GP2	0,1	0
	PSU__SAXIGP2__DATA_WIDTH	128,64,32	128
	PSU__USE__S_AXI_GP3	0,1	0
	PSU__USE_DIFF_RW_CLK_GP3	0,1	0
	PSU__SAXIGP3__DATA_WIDTH	128,64,32	128
	PSU__USE__S_AXI_GP4	0,1	0
	PSU__USE_DIFF_RW_CLK_GP4	0,1	0
	PSU__SAXIGP4__DATA_WIDTH	128,64,32	128
	PSU__USE__S_AXI_GP5	0,1	0
	PSU__USE_DIFF_RW_CLK_GP5	0,1	0
	PSU__SAXIGP5__DATA_WIDTH	128,64,32	128
	PSU__USE__S_AXI_GP6	0,1	0
	PSU__USE_DIFF_RW_CLK_GP6	0,1	0
	PSU__SAXIGP6__DATA_WIDTH	128,64,32	128
PSU__USE__S_AXI_ACE	0,1	0	
PSU__USE__FABRIC__RST	0,1	1	

Table C-1: User Parameters (Cont'd)

Parameter Description	Parameters	Range	Default Values
MIO Pin Properties like pull down, drive strength, direction and slew	PSU_MIO_0_PULLUPDOWN	pulldown,pullup,disable	pullup
	PSU_MIO_0_DRIVE_STRENGTH	2,4,8,12	12
	PSU_MIO_0_INPUT_TYPE	cmos,schmitt	schmitt
	PSU_MIO_0_SLEW	fast,slow	slow
	PSU_MIO_0_DIRECTION	<Select>,in,out,inout	<Select>
	PSU_MIO_1_PULLUPDOWN	pulldown,pullup,disable	pullup
	PSU_MIO_1_DRIVE_STRENGTH	2,4,8,12	12
	PSU_MIO_1_INPUT_TYPE	cmos,schmitt	schmitt
	PSU_MIO_1_SLEW	fast,slow	slow
	PSU_MIO_1_DIRECTION	<Select>,in,out,inout	<Select>
	PSU_MIO_2_PULLUPDOWN	pulldown,pullup,disable	pullup
	PSU_MIO_2_DRIVE_STRENGTH	2,4,8,12	12
	PSU_MIO_2_INPUT_TYPE	cmos,schmitt	schmitt
	PSU_MIO_2_SLEW	fast,slow	slow
PSU_MIO_2_DIRECTION	<Select>,in,out,inout	<Select>	

Table C-1: User Parameters (Cont'd)

Parameter Description	Parameters	Range	Default Values
MIO Pin Properties like pull down, drive strength, direction and slew (continued)	PSU_MIO_3_PULLUPDOWN	pulldown,pullup,disable	pullup
	PSU_MIO_3_DRIVE_STRENGTH	2,4,8,12	12
	PSU_MIO_3_INPUT_TYPE	cmos,schmitt	schmitt
	PSU_MIO_3_SLEW	fast,slow	slow
	PSU_MIO_3_DIRECTION	<Select>,in,out,inout	<Select>
	PSU_MIO_4_PULLUPDOWN	pulldown,pullup,disable	pullup
	PSU_MIO_4_DRIVE_STRENGTH	2,4,8,12	12
	PSU_MIO_4_INPUT_TYPE	cmos,schmitt	schmitt
	PSU_MIO_4_SLEW	fast,slow	slow
	PSU_MIO_4_DIRECTION	<Select>,in,out,inout	<Select>
	PSU_MIO_5_PULLUPDOWN	pulldown,pullup,disable	pullup
	PSU_MIO_5_DRIVE_STRENGTH	2,4,8,12	12
	PSU_MIO_5_INPUT_TYPE	cmos,schmitt	schmitt
	PSU_MIO_5_SLEW	fast,slow	slow
	PSU_MIO_5_DIRECTION	<Select>,in,out,inout	<Select>
	PSU_MIO_6_PULLUPDOWN	pulldown,pullup,disable	pullup
	PSU_MIO_6_DRIVE_STRENGTH	2,4,8,12	12
	PSU_MIO_6_INPUT_TYPE	cmos,schmitt	schmitt
	PSU_MIO_6_SLEW	fast,slow	slow
	PSU_MIO_6_DIRECTION	<Select>,in,out,inout	<Select>
	PSU_MIO_7_PULLUPDOWN	pulldown,pullup,disable	pullup
	PSU_MIO_7_DRIVE_STRENGTH	2,4,8,12	12
	PSU_MIO_7_INPUT_TYPE	cmos,schmitt	schmitt
	PSU_MIO_7_SLEW	fast,slow	slow
	PSU_MIO_7_DIRECTION	<Select>,in,out,inout	<Select>
	PSU_MIO_8_PULLUPDOWN	pulldown,pullup,disable	pullup
	PSU_MIO_8_DRIVE_STRENGTH	2,4,8,12	12
	PSU_MIO_8_INPUT_TYPE	cmos,schmitt	schmitt
	PSU_MIO_8_SLEW	fast,slow	slow
	PSU_MIO_8_DIRECTION	<Select>,in,out,inout	<Select>
PSU_MIO_9_PULLUPDOWN	pulldown,pullup,disable	pullup	
PSU_MIO_9_DRIVE_STRENGTH	2,4,8,12	12	
PSU_MIO_9_INPUT_TYPE	cmos,schmitt	schmitt	
PSU_MIO_9_SLEW	fast,slow	slow	

Table C-1: User Parameters (Cont'd)

Parameter Description	Parameters	Range	Default Values
MIO Pin Properties like pull down, drive strength, direction and slew (continued)	PSU_MIO_9_DIRECTION	<Select>,in,out,inout	<Select>
	PSU_MIO_10_PULLUPDOWN	pulldown,pullup,disable	pullup
	PSU_MIO_10_DRIVE_STRENGTH	2,4,8,12	12
	PSU_MIO_10_INPUT_TYPE	cmos,schmitt	schmitt
	PSU_MIO_10_SLEW	fast,slow	slow
	PSU_MIO_10_DIRECTION	<Select>,in,out,inout	<Select>
	PSU_MIO_11_PULLUPDOWN	pulldown,pullup,disable	pullup
	PSU_MIO_11_DRIVE_STRENGTH	2,4,8,12	12
	PSU_MIO_11_INPUT_TYPE	cmos,schmitt	schmitt
	PSU_MIO_11_SLEW	fast,slow	slow
	PSU_MIO_11_DIRECTION	<Select>,in,out,inout	<Select>
	PSU_MIO_12_PULLUPDOWN	pulldown,pullup,disable	pullup
	PSU_MIO_12_DRIVE_STRENGTH	2,4,8,12	12
	PSU_MIO_12_INPUT_TYPE	cmos,schmitt	schmitt
	PSU_MIO_12_SLEW	fast,slow	slow
	PSU_MIO_12_DIRECTION	<Select>,in,out,inout	<Select>
	PSU_MIO_13_PULLUPDOWN	pulldown,pullup,disable	pullup
	PSU_MIO_13_DRIVE_STRENGTH	2,4,8,12	12
	PSU_MIO_13_INPUT_TYPE	cmos,schmitt	schmitt
	PSU_MIO_13_SLEW	fast,slow	slow
	PSU_MIO_13_DIRECTION	<Select>,in,out,inout	<Select>
	PSU_MIO_14_PULLUPDOWN	pulldown,pullup,disable	pullup
	PSU_MIO_14_DRIVE_STRENGTH	2,4,8,12	12
	PSU_MIO_14_INPUT_TYPE	cmos,schmitt	schmitt
	PSU_MIO_14_SLEW	fast,slow	slow
	PSU_MIO_14_DIRECTION	<Select>,in,out,inout	<Select>
	PSU_MIO_15_PULLUPDOWN	pulldown,pullup,disable	pullup
	PSU_MIO_15_DRIVE_STRENGTH	2,4,8,12	12
	PSU_MIO_15_INPUT_TYPE	cmos,schmitt	schmitt
	PSU_MIO_15_SLEW	fast,slow	slow
PSU_MIO_15_DIRECTION	<Select>,in,out,inout	<Select>	
PSU_MIO_16_PULLUPDOWN	pulldown,pullup,disable	pullup	
PSU_MIO_16_DRIVE_STRENGTH	2,4,8,12	12	
PSU_MIO_16_INPUT_TYPE	cmos,schmitt	schmitt	

Table C-1: User Parameters (Cont'd)

Parameter Description	Parameters	Range	Default Values
MIO Pin Properties like pull down, drive strength, direction and slew (continued)	PSU_MIO_16_SLEW	fast,slow	slow
	PSU_MIO_16_DIRECTION	<Select>,in,out,inout	<Select>
	PSU_MIO_17_PULLUPDOWN	pulldown,pullup,disable	pullup
	PSU_MIO_17_DRIVE_STRENGTH	2,4,8,12	12
	PSU_MIO_17_INPUT_TYPE	cmos,schmitt	schmitt
	PSU_MIO_17_SLEW	fast,slow	slow
	PSU_MIO_17_DIRECTION	<Select>,in,out,inout	<Select>
	PSU_MIO_18_PULLUPDOWN	pulldown,pullup,disable	pullup
	PSU_MIO_18_DRIVE_STRENGTH	2,4,8,12	12
	PSU_MIO_18_INPUT_TYPE	cmos,schmitt	schmitt
	PSU_MIO_18_SLEW	fast,slow	slow
	PSU_MIO_18_DIRECTION	<Select>,in,out,inout	<Select>
	PSU_MIO_19_PULLUPDOWN	pulldown,pullup,disable	pullup
	PSU_MIO_19_DRIVE_STRENGTH	2,4,8,12	12
	PSU_MIO_19_INPUT_TYPE	cmos,schmitt	schmitt
	PSU_MIO_19_SLEW	fast,slow	slow
	PSU_MIO_19_DIRECTION	<Select>,in,out,inout	<Select>
	PSU_MIO_20_PULLUPDOWN	pulldown,pullup,disable	pullup
	PSU_MIO_20_DRIVE_STRENGTH	2,4,8,12	12
	PSU_MIO_20_INPUT_TYPE	cmos,schmitt	schmitt
	PSU_MIO_20_SLEW	fast,slow	slow
	PSU_MIO_20_DIRECTION	<Select>,in,out,inout	<Select>
	PSU_MIO_21_PULLUPDOWN	pulldown,pullup,disable	pullup
	PSU_MIO_21_DRIVE_STRENGTH	2,4,8,12	12
	PSU_MIO_21_INPUT_TYPE	cmos,schmitt	schmitt
	PSU_MIO_21_SLEW	fast,slow	slow
PSU_MIO_21_DIRECTION	<Select>,in,out,inout	<Select>	
PSU_MIO_22_PULLUPDOWN	pulldown,pullup,disable	pullup	
PSU_MIO_22_DRIVE_STRENGTH	2,4,8,12	12	
PSU_MIO_22_INPUT_TYPE	cmos,schmitt	schmitt	
PSU_MIO_22_SLEW	fast,slow	slow	
PSU_MIO_22_DIRECTION	<Select>,in,out,inout	<Select>	
PSU_MIO_23_PULLUPDOWN	pulldown,pullup,disable	pullup	
PSU_MIO_23_DRIVE_STRENGTH	2,4,8,12	12	

Table C-1: User Parameters (Cont'd)

Parameter Description	Parameters	Range	Default Values
MIO Pin Properties like pull down, drive strength, direction and slew (continued)	PSU_MIO_23_INPUT_TYPE	cmos,schmitt	schmitt
	PSU_MIO_23_SLEW	fast,slow	slow
	PSU_MIO_23_DIRECTION	<Select>,in,out,inout	<Select>
	PSU_MIO_24_PULLUPDOWN	pulldown,pullup,disable	pullup
	PSU_MIO_24_DRIVE_STRENGTH	2,4,8,12	12
	PSU_MIO_24_INPUT_TYPE	cmos,schmitt	schmitt
	PSU_MIO_24_SLEW	fast,slow	slow
	PSU_MIO_24_DIRECTION	<Select>,in,out,inout	<Select>
	PSU_MIO_25_PULLUPDOWN	pulldown,pullup,disable	pullup
	PSU_MIO_25_DRIVE_STRENGTH	2,4,8,12	12
	PSU_MIO_25_INPUT_TYPE	cmos,schmitt	schmitt
	PSU_MIO_25_SLEW	fast,slow	slow
	PSU_MIO_25_DIRECTION	<Select>,in,out,inout	<Select>
	PSU_MIO_26_PULLUPDOWN	pulldown,pullup,disable	pullup
	PSU_MIO_26_DRIVE_STRENGTH	2,4,8,12	12
	PSU_MIO_26_INPUT_TYPE	cmos,schmitt	schmitt
	PSU_MIO_26_SLEW	fast,slow	slow
	PSU_MIO_26_DIRECTION	<Select>,in,out,inout	<Select>
	PSU_MIO_27_PULLUPDOWN	pulldown,pullup,disable	pullup
	PSU_MIO_27_DRIVE_STRENGTH	2,4,8,12	12
	PSU_MIO_27_INPUT_TYPE	cmos,schmitt	schmitt
	PSU_MIO_27_SLEW	fast,slow	slow
	PSU_MIO_27_DIRECTION	<Select>,in,out,inout	<Select>
	PSU_MIO_28_PULLUPDOWN	pulldown,pullup,disable	pullup
	PSU_MIO_28_DRIVE_STRENGTH	2,4,8,12	12
	PSU_MIO_28_INPUT_TYPE	cmos,schmitt	schmitt
	PSU_MIO_28_SLEW	fast,slow	slow
	PSU_MIO_28_DIRECTION	<Select>,in,out,inout	<Select>
	PSU_MIO_29_PULLUPDOWN	pulldown,pullup,disable	pullup
	PSU_MIO_29_DRIVE_STRENGTH	2,4,8,12	12
PSU_MIO_29_INPUT_TYPE	cmos,schmitt	schmitt	
PSU_MIO_29_SLEW	fast,slow	slow	
PSU_MIO_29_DIRECTION	<Select>,in,out,inout	<Select>	
PSU_MIO_30_PULLUPDOWN	pulldown,pullup,disable	pullup	

Table C-1: User Parameters (Cont'd)

Parameter Description	Parameters	Range	Default Values
MIO Pin Properties like pull down, drive strength, direction and slew (continued)	PSU_MIO_30_DRIVE_STRENGTH	2,4,8,12	12
	PSU_MIO_30_INPUT_TYPE	cmos,schmitt	schmitt
	PSU_MIO_30_SLEW	fast,slow	slow
	PSU_MIO_30_DIRECTION	<Select>,in,out,inout	<Select>
	PSU_MIO_31_PULLUPDOWN	pulldown,pullup,disable	pullup
	PSU_MIO_31_DRIVE_STRENGTH	2,4,8,12	12
	PSU_MIO_31_INPUT_TYPE	cmos,schmitt	schmitt
	PSU_MIO_31_SLEW	fast,slow	slow
	PSU_MIO_31_DIRECTION	<Select>,in,out,inout	<Select>
	PSU_MIO_32_PULLUPDOWN	pulldown,pullup,disable	pullup
	PSU_MIO_32_DRIVE_STRENGTH	2,4,8,12	12
	PSU_MIO_32_INPUT_TYPE	cmos,schmitt	schmitt
	PSU_MIO_32_SLEW	fast,slow	slow
	PSU_MIO_32_DIRECTION	<Select>,in,out,inout	<Select>
	PSU_MIO_33_PULLUPDOWN	pulldown,pullup,disable	pullup
	PSU_MIO_33_DRIVE_STRENGTH	2,4,8,12	12
	PSU_MIO_33_INPUT_TYPE	cmos,schmitt	schmitt
	PSU_MIO_33_SLEW	fast,slow	slow
	PSU_MIO_33_DIRECTION	<Select>,in,out,inout	<Select>
	PSU_MIO_34_PULLUPDOWN	pulldown,pullup,disable	pullup
	PSU_MIO_34_DRIVE_STRENGTH	2,4,8,12	12
	PSU_MIO_34_INPUT_TYPE	cmos,schmitt	schmitt
	PSU_MIO_34_SLEW	fast,slow	slow
	PSU_MIO_34_DIRECTION	<Select>,in,out,inout	<Select>
	PSU_MIO_35_PULLUPDOWN	pulldown,pullup,disable	pullup
	PSU_MIO_35_DRIVE_STRENGTH	2,4,8,12	12
	PSU_MIO_35_INPUT_TYPE	cmos,schmitt	schmitt
	PSU_MIO_35_SLEW	fast,slow	slow
	PSU_MIO_35_DIRECTION	<Select>,in,out,inout	<Select>
	PSU_MIO_36_PULLUPDOWN	pulldown,pullup,disable	pullup
PSU_MIO_36_DRIVE_STRENGTH	2,4,8,12	12	
PSU_MIO_36_INPUT_TYPE	cmos,schmitt	schmitt	
PSU_MIO_36_SLEW	fast,slow	slow	
PSU_MIO_36_DIRECTION	<Select>,in,out,inout	<Select>	

Table C-1: User Parameters (Cont'd)

Parameter Description	Parameters	Range	Default Values
MIO Pin Properties like pull down, drive strength, direction and slew (continued)	PSU_MIO_37_PULLUPDOWN	pullup,pullup,disable	pullup
	PSU_MIO_37_DRIVE_STRENGTH	2,4,8,12	12
	PSU_MIO_37_INPUT_TYPE	cmos,schmitt	schmitt
	PSU_MIO_37_SLEW	fast,slow	slow
	PSU_MIO_37_DIRECTION	<Select>,in,out,inout	<Select>
	PSU_MIO_38_PULLUPDOWN	pullup,pullup,disable	pullup
	PSU_MIO_38_DRIVE_STRENGTH	2,4,8,12	12
	PSU_MIO_38_INPUT_TYPE	cmos,schmitt	schmitt
	PSU_MIO_38_SLEW	fast,slow	slow
	PSU_MIO_38_DIRECTION	<Select>,in,out,inout	<Select>
	PSU_MIO_39_PULLUPDOWN	pullup,pullup,disable	pullup
	PSU_MIO_39_DRIVE_STRENGTH	2,4,8,12	12
	PSU_MIO_39_INPUT_TYPE	cmos,schmitt	schmitt
	PSU_MIO_39_SLEW	fast,slow	slow
	PSU_MIO_39_DIRECTION	<Select>,in,out,inout	<Select>
	PSU_MIO_40_PULLUPDOWN	pullup,pullup,disable	pullup
	PSU_MIO_40_DRIVE_STRENGTH	2,4,8,12	12
	PSU_MIO_40_INPUT_TYPE	cmos,schmitt	schmitt
	PSU_MIO_40_SLEW	fast,slow	slow
	PSU_MIO_40_DIRECTION	<Select>,in,out,inout	<Select>
	PSU_MIO_41_PULLUPDOWN	pullup,pullup,disable	pullup
	PSU_MIO_41_DRIVE_STRENGTH	2,4,8,12	12
	PSU_MIO_41_INPUT_TYPE	cmos,schmitt	schmitt
	PSU_MIO_41_SLEW	fast,slow	slow
	PSU_MIO_41_DIRECTION	<Select>,in,out,inout	<Select>
	PSU_MIO_42_PULLUPDOWN	pullup,pullup,disable	pullup
	PSU_MIO_42_DRIVE_STRENGTH	2,4,8,12	12
	PSU_MIO_42_INPUT_TYPE	cmos,schmitt	schmitt
	PSU_MIO_42_SLEW	fast,slow	slow
	PSU_MIO_42_DIRECTION	<Select>,in,out,inout	<Select>
PSU_MIO_43_PULLUPDOWN	pullup,pullup,disable	pullup	
PSU_MIO_43_DRIVE_STRENGTH	2,4,8,12	12	
PSU_MIO_43_INPUT_TYPE	cmos,schmitt	schmitt	
PSU_MIO_43_SLEW	fast,slow	slow	

Table C-1: User Parameters (Cont'd)

Parameter Description	Parameters	Range	Default Values
MIO Pin Properties like pull down, drive strength, direction and slew (continued)	PSU_MIO_43_DIRECTION	<Select>,in,out,inout	<Select>
	PSU_MIO_44_PULLUPDOWN	pulldown,pullup,disable	pullup
	PSU_MIO_44_DRIVE_STRENGTH	2,4,8,12	12
	PSU_MIO_44_INPUT_TYPE	cmos,schmitt	schmitt
	PSU_MIO_44_SLEW	fast,slow	slow
	PSU_MIO_44_DIRECTION	<Select>,in,out,inout	<Select>
	PSU_MIO_45_PULLUPDOWN	pulldown,pullup,disable	pullup
	PSU_MIO_45_DRIVE_STRENGTH	2,4,8,12	12
	PSU_MIO_45_INPUT_TYPE	cmos,schmitt	schmitt
	PSU_MIO_45_SLEW	fast,slow	slow
	PSU_MIO_45_DIRECTION	<Select>,in,out,inout	<Select>
	PSU_MIO_46_PULLUPDOWN	pulldown,pullup,disable	pullup
	PSU_MIO_46_DRIVE_STRENGTH	2,4,8,12	12
	PSU_MIO_46_INPUT_TYPE	cmos,schmitt	schmitt
	PSU_MIO_46_SLEW	fast,slow	slow
	PSU_MIO_46_DIRECTION	<Select>,in,out,inout	<Select>
	PSU_MIO_47_PULLUPDOWN	pulldown,pullup,disable	pullup
	PSU_MIO_47_DRIVE_STRENGTH	2,4,8,12	12
	PSU_MIO_47_INPUT_TYPE	cmos,schmitt	schmitt
	PSU_MIO_47_SLEW	fast,slow	slow
	PSU_MIO_47_DIRECTION	<Select>,in,out,inout	<Select>
	PSU_MIO_48_PULLUPDOWN	pulldown,pullup,disable	pullup
	PSU_MIO_48_DRIVE_STRENGTH	2,4,8,12	12
	PSU_MIO_48_INPUT_TYPE	cmos,schmitt	schmitt
	PSU_MIO_48_SLEW	fast,slow	slow
	PSU_MIO_48_DIRECTION	<Select>,in,out,inout	<Select>
	PSU_MIO_49_PULLUPDOWN	pulldown,pullup,disable	pullup
	PSU_MIO_49_DRIVE_STRENGTH	2,4,8,12	12
	PSU_MIO_49_INPUT_TYPE	cmos,schmitt	schmitt
	PSU_MIO_49_SLEW	fast,slow	slow
PSU_MIO_49_DIRECTION	<Select>,in,out,inout	<Select>	
PSU_MIO_50_PULLUPDOWN	pulldown,pullup,disable	pullup	
PSU_MIO_50_DRIVE_STRENGTH	2,4,8,12	12	
PSU_MIO_50_INPUT_TYPE	cmos,schmitt	schmitt	

Table C-1: User Parameters (Cont'd)

Parameter Description	Parameters	Range	Default Values
MIO Pin Properties like pull down, drive strength, direction and slew (continued)	PSU_MIO_50_SLEW	fast,slow	slow
	PSU_MIO_50_DIRECTION	<Select>,in,out,inout	<Select>
	PSU_MIO_51_PULLUPDOWN	pulldown,pullup,disable	pullup
	PSU_MIO_51_DRIVE_STRENGTH	2,4,8,12	12
	PSU_MIO_51_INPUT_TYPE	cmos,schmitt	schmitt
	PSU_MIO_51_SLEW	fast,slow	slow
	PSU_MIO_51_DIRECTION	<Select>,in,out,inout	<Select>
	PSU_MIO_52_PULLUPDOWN	pulldown,pullup,disable	pullup
	PSU_MIO_52_DRIVE_STRENGTH	2,4,8,12	12
	PSU_MIO_52_INPUT_TYPE	cmos,schmitt	schmitt
	PSU_MIO_52_SLEW	fast,slow	slow
	PSU_MIO_52_DIRECTION	<Select>,in,out,inout	<Select>
	PSU_MIO_53_PULLUPDOWN	pulldown,pullup,disable	pullup
	PSU_MIO_53_DRIVE_STRENGTH	2,4,8,12	12
	PSU_MIO_53_INPUT_TYPE	cmos,schmitt	schmitt
	PSU_MIO_53_SLEW	fast,slow	slow
	PSU_MIO_53_DIRECTION	<Select>,in,out,inout	<Select>
	PSU_MIO_54_PULLUPDOWN	pulldown,pullup,disable	pullup
	PSU_MIO_54_DRIVE_STRENGTH	2,4,8,12	12
	PSU_MIO_54_INPUT_TYPE	cmos,schmitt	schmitt
	PSU_MIO_54_SLEW	fast,slow	slow
	PSU_MIO_54_DIRECTION	<Select>,in,out,inout	<Select>
	PSU_MIO_55_PULLUPDOWN	pulldown,pullup,disable	pullup
	PSU_MIO_55_DRIVE_STRENGTH	2,4,8,12	12
	PSU_MIO_55_INPUT_TYPE	cmos,schmitt	schmitt
	PSU_MIO_55_SLEW	fast,slow	slow
	PSU_MIO_55_DIRECTION	<Select>,in,out,inout	<Select>
	PSU_MIO_56_PULLUPDOWN	pulldown,pullup,disable	pullup
	PSU_MIO_56_DRIVE_STRENGTH	2,4,8,12	12
	PSU_MIO_56_INPUT_TYPE	cmos,schmitt	schmitt
PSU_MIO_56_SLEW	fast,slow	slow	
PSU_MIO_56_DIRECTION	<Select>,in,out,inout	<Select>	
PSU_MIO_57_PULLUPDOWN	pulldown,pullup,disable	pullup	
PSU_MIO_57_DRIVE_STRENGTH	2,4,8,12	12	

Table C-1: User Parameters (Cont'd)

Parameter Description	Parameters	Range	Default Values
MIO Pin Properties like pull down, drive strength, direction and slew (continued)	PSU_MIO_57_INPUT_TYPE	cmos,schmitt	schmitt
	PSU_MIO_57_SLEW	fast,slow	slow
	PSU_MIO_57_DIRECTION	<Select>,in,out,inout	<Select>
	PSU_MIO_58_PULLUPDOWN	pulldown,pullup,disable	pullup
	PSU_MIO_58_DRIVE_STRENGTH	2,4,8,12	12
	PSU_MIO_58_INPUT_TYPE	cmos,schmitt	schmitt
	PSU_MIO_58_SLEW	fast,slow	slow
	PSU_MIO_58_DIRECTION	<Select>,in,out,inout	<Select>
	PSU_MIO_59_PULLUPDOWN	pulldown,pullup,disable	pullup
	PSU_MIO_59_DRIVE_STRENGTH	2,4,8,12	12
	PSU_MIO_59_INPUT_TYPE	cmos,schmitt	schmitt
	PSU_MIO_59_SLEW	fast,slow	slow
	PSU_MIO_59_DIRECTION	<Select>,in,out,inout	<Select>
	PSU_MIO_60_PULLUPDOWN	pulldown,pullup,disable	pullup
	PSU_MIO_60_DRIVE_STRENGTH	2,4,8,12	12
	PSU_MIO_60_INPUT_TYPE	cmos,schmitt	schmitt
	PSU_MIO_60_SLEW	fast,slow	slow
	PSU_MIO_60_DIRECTION	<Select>,in,out,inout	<Select>
	PSU_MIO_61_PULLUPDOWN	pulldown,pullup,disable	pullup
	PSU_MIO_61_DRIVE_STRENGTH	2,4,8,12	12
	PSU_MIO_61_INPUT_TYPE	cmos,schmitt	schmitt
	PSU_MIO_61_SLEW	fast,slow	slow
	PSU_MIO_61_DIRECTION	<Select>,in,out,inout	<Select>
	PSU_MIO_62_PULLUPDOWN	pulldown,pullup,disable	pullup
	PSU_MIO_62_DRIVE_STRENGTH	2,4,8,12	12
	PSU_MIO_62_INPUT_TYPE	cmos,schmitt	schmitt
	PSU_MIO_62_SLEW	fast,slow	slow
	PSU_MIO_62_DIRECTION	<Select>,in,out,inout	<Select>
	PSU_MIO_63_PULLUPDOWN	pulldown,pullup,disable	pullup
	PSU_MIO_63_DRIVE_STRENGTH	2,4,8,12	12
	PSU_MIO_63_INPUT_TYPE	cmos,schmitt	schmitt
	PSU_MIO_63_SLEW	fast,slow	slow
PSU_MIO_63_DIRECTION	<Select>,in,out,inout	<Select>	
PSU_MIO_64_PULLUPDOWN	pulldown,pullup,disable	pullup	

Table C-1: User Parameters (Cont'd)

Parameter Description	Parameters	Range	Default Values
MIO Pin Properties like pull down, drive strength, direction and slew (continued)	PSU_MIO_64_DRIVE_STRENGTH	2,4,8,12	12
	PSU_MIO_64_INPUT_TYPE	cmos,schmitt	schmitt
	PSU_MIO_64_SLEW	fast,slow	slow
	PSU_MIO_64_DIRECTION	<Select>,in,out,inout	<Select>
	PSU_MIO_65_PULLUPDOWN	pulldown,pullup,disable	pullup
	PSU_MIO_65_DRIVE_STRENGTH	2,4,8,12	12
	PSU_MIO_65_INPUT_TYPE	cmos,schmitt	schmitt
	PSU_MIO_65_SLEW	fast,slow	slow
	PSU_MIO_65_DIRECTION	<Select>,in,out,inout	<Select>
	PSU_MIO_66_PULLUPDOWN	pulldown,pullup,disable	pullup
	PSU_MIO_66_DRIVE_STRENGTH	2,4,8,12	12
	PSU_MIO_66_INPUT_TYPE	cmos,schmitt	schmitt
	PSU_MIO_66_SLEW	fast,slow	slow
	PSU_MIO_66_DIRECTION	<Select>,in,out,inout	<Select>
	PSU_MIO_67_PULLUPDOWN	pulldown,pullup,disable	pullup
	PSU_MIO_67_DRIVE_STRENGTH	2,4,8,12	12
	PSU_MIO_67_INPUT_TYPE	cmos,schmitt	schmitt
	PSU_MIO_67_SLEW	fast,slow	slow
	PSU_MIO_67_DIRECTION	<Select>,in,out,inout	<Select>
	PSU_MIO_68_PULLUPDOWN	pulldown,pullup,disable	pullup
	PSU_MIO_68_DRIVE_STRENGTH	2,4,8,12	12
	PSU_MIO_68_INPUT_TYPE	cmos,schmitt	schmitt
	PSU_MIO_68_SLEW	fast,slow	slow
	PSU_MIO_68_DIRECTION	<Select>,in,out,inout	<Select>
	PSU_MIO_69_PULLUPDOWN	pulldown,pullup,disable	pullup
	PSU_MIO_69_DRIVE_STRENGTH	2,4,8,12	12
	PSU_MIO_69_INPUT_TYPE	cmos,schmitt	schmitt
	PSU_MIO_69_SLEW	fast,slow	slow
PSU_MIO_69_DIRECTION	<Select>,in,out,inout	<Select>	
PSU_MIO_70_PULLUPDOWN	pulldown,pullup,disable	pullup	
PSU_MIO_70_DRIVE_STRENGTH	2,4,8,12	12	
PSU_MIO_70_INPUT_TYPE	cmos,schmitt	schmitt	
PSU_MIO_70_SLEW	fast,slow	slow	
PSU_MIO_70_DIRECTION	<Select>,in,out,inout	<Select>	

Table C-1: User Parameters (Cont'd)

Parameter Description	Parameters	Range	Default Values
MIO Pin Properties like pull down, drive strength, direction and slew (continued)	PSU_MIO_71_PULLUPDOWN	pullup,pullup,disable	pullup
	PSU_MIO_71_DRIVE_STRENGTH	2,4,8,12	12
	PSU_MIO_71_INPUT_TYPE	cmos,schmitt	schmitt
	PSU_MIO_71_SLEW	fast,slow	slow
	PSU_MIO_71_DIRECTION	<Select>,in,out,inout	<Select>
	PSU_MIO_72_PULLUPDOWN	pullup,pullup,disable	pullup
	PSU_MIO_72_DRIVE_STRENGTH	2,4,8,12	12
	PSU_MIO_72_INPUT_TYPE	cmos,schmitt	schmitt
	PSU_MIO_72_SLEW	fast,slow	slow
	PSU_MIO_72_DIRECTION	<Select>,in,out,inout	<Select>
	PSU_MIO_73_PULLUPDOWN	pullup,pullup,disable	pullup
	PSU_MIO_73_DRIVE_STRENGTH	2,4,8,12	12
	PSU_MIO_73_INPUT_TYPE	cmos,schmitt	schmitt
	PSU_MIO_73_SLEW	fast,slow	slow
	PSU_MIO_73_DIRECTION	<Select>,in,out,inout	<Select>
	PSU_MIO_74_PULLUPDOWN	pullup,pullup,disable	pullup
	PSU_MIO_74_DRIVE_STRENGTH	2,4,8,12	12
	PSU_MIO_74_INPUT_TYPE	cmos,schmitt	schmitt
	PSU_MIO_74_SLEW	fast,slow	slow
	PSU_MIO_74_DIRECTION	<Select>,in,out,inout	<Select>
	PSU_MIO_75_PULLUPDOWN	pullup,pullup,disable	pullup
	PSU_MIO_75_DRIVE_STRENGTH	2,4,8,12	12
	PSU_MIO_75_INPUT_TYPE	cmos,schmitt	schmitt
	PSU_MIO_75_SLEW	fast,slow	slow
	PSU_MIO_75_DIRECTION	<Select>,in,out,inout	<Select>
	PSU_MIO_76_PULLUPDOWN	pullup,pullup,disable	pullup
	PSU_MIO_76_DRIVE_STRENGTH	2,4,8,12	12
	PSU_MIO_76_INPUT_TYPE	cmos,schmitt	schmitt
PSU_MIO_76_SLEW	fast,slow	slow	
PSU_MIO_76_DIRECTION	<Select>,in,out,inout	<Select>	
PSU_MIO_77_PULLUPDOWN	pullup,pullup,disable	pullup	
PSU_MIO_77_DRIVE_STRENGTH	2,4,8,12	12	
PSU_MIO_77_INPUT_TYPE	cmos,schmitt	schmitt	
PSU_MIO_77_SLEW	fast,slow	slow	

Table C-1: User Parameters (Cont'd)

Parameter Description	Parameters	Range	Default Values
	PSU_MIO_77_DIRECTION	<Select>,in,out,inout	<Select>
Bank 0 Standard	PSU_BANK_0_IO_STANDARD	LVC MOS18,LVC MOS25,LV CMOS33	LVC MOS33
Bank 1 Standard	PSU_BANK_1_IO_STANDARD	LVC MOS18,LVC MOS25,LV CMOS33	LVC MOS33
Bank 2 Standard	PSU_BANK_2_IO_STANDARD	LVC MOS18,LVC MOS25,LV CMOS33	LVC MOS33
Bank 2 Standard	PSU_BANK_3_IO_STANDARD	LVC MOS18,LVC MOS25 ,LVC MOS33	LVC MOS3 3
Clocking related Parameters and Divisors	PSU__CRF_APB__APLL_CTRL__FRACDATA		0
	PSU__CRF_APB__VPLL_CTRL__FRACDATA		0
	PSU__CRF_APB__DPLL_CTRL__FRACDATA		0
	PSU__CRL_APB__IOPLL_CTRL__ FRACDATA		0
	PSU__CRL_APB__RPLL_CTRL__FRACDATA		0
	PSU__CRF_APB__DPLL_CTRL__DIV2	0,1	1
	PSU__CRF_APB__APLL_CTRL__DIV2	0,1	1
	PSU__CRF_APB__VPLL_CTRL__DIV2	0,1	1
	PSU__CRL_APB__IOPLL_CTRL__DIV2	0,1	1
	PSU__CRL_APB__RPLL_CTRL__DIV2	0,1	1
	PSU__CRF_APB__APLL_CTRL__FBDIV		72
	PSU__CRF_APB__DPLL_CTRL__FBDIV		60
	PSU__CRF_APB__VPLL_CTRL__FBDIV		90
	PSU__CRF_APB__APLL_TO_LPD_CTRL__ DIVISOR0		3
	PSU__CRF_APB__DPLL_TO_LPD_CTRL__ DIVISOR0		2
	PSU__CRF_APB__VPLL_TO_LPD_CTRL__ DIVISOR0		3
	PSU__CRF_APB__ACPU_CTRL__DIVISOR0		1
PSU__CRF_APB__DBG_TRACE_CTRL__ DIVISOR0		2	

Table C-1: User Parameters (Cont'd)

Parameter Description	Parameters	Range	Default Values
Display Port	PSU__DISPLAYPORT__PERIPHERAL__ENABLE	0,1	0
	PSU__DISPLAYPORT__LANE0__ENABLE	0,1	0
	PSU__DISPLAYPORT__LANE0__IO	<Select>,GT Lane1,GT Lane3	<Select>
	PSU__DISPLAYPORT__LANE1__ENABLE	0,1	0
	PSU__DISPLAYPORT__LANE1__IO	<Select>,GT Lane0,GT Lane2	<Select>

Table C-1: User Parameters (Cont'd)

Parameter Description	Parameters	Range	Default Values
Clocking related Parameters and Divisors	PSU__CRF_APB__DBG_FPD_CTRL__DIVISOR0		2
	PSU__CRF_APB__APM_CTRL__DIVISOR0		1
	PSU__CRF_APB__DP_VIDEO_REF_CTRL__DIVISOR0		5
	PSU__CRF_APB__DP_VIDEO_REF_CTRL__DIVISOR1		1
	PSU__CRF_APB__DP_AUDIO_REF_CTRL__DIVISOR0		64
	PSU__CRF_APB__DP_AUDIO_REF_CTRL__DIVISOR1		1
	PSU__CRF_APB__DP_STC_REF_CTRL__DIVISOR0		6
	PSU__CRF_APB__DP_STC_REF_CTRL__DIVISOR1		10
	PSU__CRF_APB__DDR_CTRL__DIVISOR0		3
	PSU__CRF_APB__GPU_REF_CTRL__DIVISOR0		2
	PSU__CRF_APB__AFI0_REF_CTRL__DIVISOR0		2
	PSU__CRF_APB__AFI0_REF__ENABLE	0,1	0
	PSU__CRF_APB__AFI1_REF_CTRL__DIVISOR0		2
	PSU__CRF_APB__AFI1_REF__ENABLE	0,1	0
	PSU__CRF_APB__AFI2_REF_CTRL__DIVISOR0		2
	PSU__CRF_APB__AFI2_REF__ENABLE	0,1	0
	PSU__CRF_APB__AFI3_REF_CTRL__DIVISOR0		2
	PSU__CRF_APB__AFI3_REF__ENABLE	0,1	0
	PSU__CRF_APB__AFI4_REF_CTRL__DIVISOR0		2
	PSU__CRF_APB__AFI4_REF__ENABLE	0,1	0
	PSU__CRF_APB__AFI5_REF_CTRL__DIVISOR0		2
PSU__CRF_APB__AFI5_REF__ENABLE	0,1	0	
PSU__CRF_APB__SATA_REF_CTRL__DIVISOR0		5	

Table C-1: User Parameters (Cont'd)

Parameter Description	Parameters	Range	Default Values
SATA Related Parameters	PSU__SATA__PERIPHERAL__ENABLE	0,1	0
	PSU__SATA__LANE0__ENABLE	0,1	0
	PSU__SATA__LANE0__IO	<Select>,GT Lane0,GT Lane2	<Select>
	PSU__SATA__LANE1__ENABLE	0,1	0
	PSU__SATA__LANE1__IO	<Select>,GT Lane1,GT Lane3	<Select>
Clocking related Parameters and Divisors	PSU__CRF__APB__PCIE_REF_CTRL__DIVISOR0		6
	PSU__CRL__APB__PL0_REF_CTRL__DIVISOR0		15
	PSU__CRL__APB__PL1_REF_CTRL__DIVISOR0		4
	PSU__CRL__APB__PL2_REF_CTRL__DIVISOR0		4
	PSU__CRL__APB__PL3_REF_CTRL__DIVISOR0		4
	PSU__CRL__APB__PL0_REF_CTRL__DIVISOR1		1
	PSU__CRL__APB__PL1_REF_CTRL__DIVISOR1		1
	PSU__CRL__APB__PL2_REF_CTRL__DIVISOR1		1
	PSU__CRL__APB__PL3_REF_CTRL__DIVISOR1		1
	PSU__CRL__APB__AMS_REF_CTRL__DIVISOR0		30
	PSU__CRL__APB__AMS_REF_CTRL__DIVISOR1		1
	PSU__CRL__APB__TIMESTAMP_REF_CTRL__DIVISOR0		15
	PSU__CRL__APB__AFI6_REF_CTRL__DIVISOR0		3
	PSU__CRL__APB__AFI6__ENABLE	0,1	0
	PSU__CRL__APB__USB3_DUAL_REF_CTRL__DIVISOR0		5
	PSU__CRL__APB__USB3_DUAL_REF_CTRL__DIVISOR1		15
	PSU__CRL__APB__USB3__ENABLE	0,1	0

Table C-1: User Parameters (Cont'd)

Parameter Description	Parameters	Range	Default Values
	PSU__CRF_APB__GDMA_REF_CTRL__ DIVISOR0		2

Table C-1: User Parameters (Cont'd)

Parameter Description	Parameters	Range	Default Values
Clocking related Parameters and Divisors (continued)	PSU__CRF_APB__DPDMA_REF_CTRL__DIVISOR0		2
	PSU__CRF_APB__TOPSW_MAIN_CTRL__DIVISOR0		2
	PSU__CRF_APB__TOPSW_LSBUS_CTRL__DIVISOR0		5
	PSU__CRF_APB__GTGREF0_REF_CTRL__DIVISOR0		-1
	PSU__CRF_APB__GTGREF0__ENABLE	NA	NA
	PSU__CRF_APB__DBG_TSTMP_CTRL__DIVISOR0		2
	PSU__CRL_APB__IOPLL_CTRL__FBDIV		90
	PSU__CRL_APB__RPLL_CTRL__FBDIV		90
	PSU__CRL_APB__IOPLL_TO_FPD_CTRL__DIVISOR0		3
	PSU__CRL_APB__RPLL_TO_FPD_CTRL__DIVISOR0		3
	PSU__CRL_APB__GEM0_REF_CTRL__DIVISOR0		12
	PSU__CRL_APB__GEM1_REF_CTRL__DIVISOR0		12
	PSU__CRL_APB__GEM2_REF_CTRL__DIVISOR0		12
	PSU__CRL_APB__GEM3_REF_CTRL__DIVISOR0		12
	PSU__CRL_APB__GEM0_REF_CTRL__DIVISOR1		1
	PSU__CRL_APB__GEM1_REF_CTRL__DIVISOR1		1
	PSU__CRL_APB__GEM2_REF_CTRL__DIVISOR1		1
	PSU__CRL_APB__GEM3_REF_CTRL__DIVISOR1		1
	PSU__CRL_APB__GEM_TSU_REF_CTRL__DIVISOR0		4
	PSU__CRL_APB__GEM_TSU_REF_CTRL__DIVISOR1		1
PSU__CRL_APB__USB0_BUS_REF_CTRL__DIVISOR0		6	

Table C-1: User Parameters (Cont'd)

Parameter Description	Parameters	Range	Default Values
Clocking related Parameters and Divisors (continued)	PSU__CRL_APB__USB0_BUS_REF_CTRL__DIVISOR1		1
	PSU__CRL_APB__USB1_BUS_REF_CTRL__DIVISOR0		6
	PSU__CRL_APB__USB1_BUS_REF_CTRL__DIVISOR1		1
	PSU__CRL_APB__QSPI_REF_CTRL__DIVISOR0		5
	PSU__CRL_APB__QSPI_REF_CTRL__DIVISOR1		1
	PSU__CRL_APB__SDIO0_REF_CTRL__DIVISOR0		7
	PSU__CRL_APB__SDIO0_REF_CTRL__DIVISOR1		1
	PSU__CRL_APB__SDIO1_REF_CTRL__DIVISOR0		7
	PSU__CRL_APB__SDIO1_REF_CTRL__DIVISOR1		1
	PSU__CRL_APB__UART0_REF_CTRL__DIVISOR0		15
	PSU__CRL_APB__UART0_REF_CTRL__DIVISOR1		1
	PSU__CRL_APB__UART1_REF_CTRL__DIVISOR0		15
	PSU__CRL_APB__UART1_REF_CTRL__DIVISOR1		1
	PSU__CRL_APB__I2C0_REF_CTRL__DIVISOR0		15
	PSU__CRL_APB__I2C0_REF_CTRL__DIVISOR1		1
	PSU__CRL_APB__I2C1_REF_CTRL__DIVISOR0		15
	PSU__CRL_APB__I2C1_REF_CTRL__DIVISOR1		1
	PSU__CRL_APB__SPI0_REF_CTRL__DIVISOR0		7
	PSU__CRL_APB__SPI0_REF_CTRL__DIVISOR1		1
	PSU__CRL_APB__SPI1_REF_CTRL__DIVISOR0		7

Table C-1: User Parameters (Cont'd)

Parameter Description	Parameters	Range	Default Values
Clocking related Parameters and Divisors (continued)	PSU__CRL_APB__SPI1_REF_CTRL__DIVISOR1		1
	PSU__CRL_APB__CAN0_REF_CTRL__DIVISOR0		15
	PSU__CRL_APB__CAN0_REF_CTRL__DIVISOR1		1
	PSU__CRL_APB__CAN1_REF_CTRL__DIVISOR0		15
	PSU__CRL_APB__CAN1_REF_CTRL__DIVISOR1		1
	PSU__CRL_APB__DEBUG_R5_ATCLK_CTRL__DIVISOR0		6
	PSU__CRL_APB__CPU_R5_CTRL__DIVISOR0		3
	PSU__CRL_APB__OCM_MAIN_CTRL__DIVISOR0		3
	PSU__CRL_APB__IOU_SWITCH_CTRL__DIVISOR0		6
	PSU__CRL_APB__CSU_PLL_CTRL__DIVISOR0		3
	PSU__CRL_APB__PCAP_CTRL__DIVISOR0		6
	PSU__CRL_APB__LPD_LSBUS_CTRL__DIVISOR0		15
	PSU__CRL_APB__LPD_SWITCH_CTRL__DIVISOR0		3
	PSU__CRL_APB__DBG_LPD_CTRL__DIVISOR0		6
	PSU__CRL_APB__NAND_REF_CTRL__DIVISOR0		15
	PSU__CRL_APB__NAND_REF_CTRL__DIVISOR1		1
	PSU__CRL_APB__ADMA_REF_CTRL__DIVISOR0		3
	PSU__CRF_APB__APLL_CTRL__SRCSEL	PSS_REF_CLK	PSS_REF_CLK
	PSU__CRF_APB__DPLL_CTRL__SRCSEL	PSS_REF_CLK	PSS_REF_CLK
	PSU__CRF_APB__VPLL_CTRL__SRCSEL	PSS_REF_CLK	PSS_REF_CLK
PSU__CRF_APB__ACPU_CTRL__SRCSEL	APLL,DPLL,VPLL	APLL	

Table C-1: User Parameters (Cont'd)

Parameter Description	Parameters	Range	Default Values
Clocking related Parameters and Divisors (continued)	PSU__CRF_APB__DBG_TRACE_CTRL__SRCSEL	IOPLL,DPLL,APLL	IOPLL
	PSU__CRF_APB__DBG_FPD_CTRL__SRCSEL	IOPLL,DPLL,APLL	IOPLL
	PSU__CRF_APB__APM_CTRL__SRCSEL	<Select>	<Select>
	PSU__CRF_APB__DP_VIDEO_REF_CTRL__SRCSEL	VPLL,DPLL,RPLL	VPLL
	PSU__CRF_APB__DP_AUDIO_REF_CTRL__SRCSEL	VPLL,DPLL,RPLL	VPLL
	PSU__CRF_APB__DP_STC_REF_CTRL__SRCSEL	VPLL,DPLL,RPLL, FMIO_AUDIO_STREAM_CLK	VPLL
	PSU__CRF_APB__DDR_CTRL__SRCSEL	DPLL,VPLL	DPLL
	PSU__CRF_APB__GPU_REF_CTRL__SRCSEL	IOPLL,VPLL,DPLL	DPLL
	PSU__CRF_APB__AFIO_REF_CTRL__SRCSEL	APLL,VPLL,DPLL	DPLL
	PSU__CRF_APB__AFI1_REF_CTRL__SRCSEL	APLL,VPLL,DPLL	DPLL
	PSU__CRF_APB__AFI2_REF_CTRL__SRCSEL	APLL,VPLL,DPLL	DPLL
	PSU__CRF_APB__AFI3_REF_CTRL__SRCSEL	APLL,VPLL,DPLL	DPLL
	PSU__CRF_APB__AFI4_REF_CTRL__SRCSEL	APLL,VPLL,DPLL	DPLL
	PSU__CRF_APB__AFI5_REF_CTRL__SRCSEL	APLL,VPLL,DPLL	DPLL
	PSU__CRF_APB__SATA_REF_CTRL__SRCSEL	APLL,IOPLL,DPLL	IOPLL
	PSU__CRF_APB__PCIE_REF_CTRL__SRCSEL	IOPLL,RPLL,DPLL	IOPLL
	PSU__CRL_APB__PL0_REF_CTRL__SRCSEL	DPLL,IOPLL,RPLL	RPLL
	PSU__CRL_APB__PL1_REF_CTRL__SRCSEL	DPLL,IOPLL,RPLL	RPLL
	PSU__CRL_APB__PL2_REF_CTRL__SRCSEL	DPLL,IOPLL,RPLL	RPLL
	PSU__CRL_APB__PL3_REF_CTRL__SRCSEL	DPLL,IOPLL,RPLL	RPLL
	PSU__CRF_APB__GDMA_REF_CTRL__SRCSEL	APLL,VPLL,DPLL	APLL
	PSU__CRF_APB__DPDMA_REF_CTRL__SRCSEL	APLL,VPLL,DPLL	APLL
	PSU__CRF_APB__TOPSW_MAIN_CTRL__SRCSEL	APLL,VPLL,DPLL	DPLL

Table C-1: User Parameters (Cont'd)

Parameter Description	Parameters	Range	Default Values
Clocking related Parameters and Divisors (continued)	PSU__CRF__APB__TOPSW_LSBUS_CTRL__SRCSEL	APLL,IOPLL,DPLL	IOPLL
	PSU__CRF__APB__GTGREF0_REF_CTRL__SRCSEL	NA	NA
	PSU__CRF__APB__DBG_TSTMP_CTRL__SRCSEL	APLL,DPLL,IOPLL	IOPLL
	PSU__CRL__APB__IOPLL_CTRL__SRCSEL	PSS_REF_CLK	PSS_REF_CLK
	PSU__CRL__APB__RPLL_CTRL__SRCSEL	PSS_REF_CLK	PSS_REF_CLK
	PSU__CRL__APB__GEM0_REF_CTRL__SRCSEL	DPLL,IOPLL,RPLL	IOPLL
	PSU__CRL__APB__GEM1_REF_CTRL__SRCSEL	DPLL,IOPLL,RPLL	IOPLL
	PSU__CRL__APB__GEM2_REF_CTRL__SRCSEL	DPLL,IOPLL,RPLL	IOPLL
	PSU__CRL__APB__GEM3_REF_CTRL__SRCSEL	DPLL,IOPLL,RPLL	IOPLL
	PSU__CRL__APB__GEM_TSU_REF_CTRL__SRCSEL	IOPLL,RPLL,DPLL	RPLL
	PSU__CRL__APB__USB0_BUS_REF_CTRL__SRCSEL	DPLL,IOPLL,RPLL	IOPLL
	PSU__CRL__APB__USB1_BUS_REF_CTRL__SRCSEL	DPLL,IOPLL,RPLL	IOPLL
	PSU__CRL__APB__QSPI_REF_CTRL__SRCSEL	DPLL,IOPLL,RPLL	IOPLL
	PSU__CRL__APB__SDIO0_REF_CTRL__SRCSEL	VPLL,IOPLL,RPLL	RPLL
	PSU__CRL__APB__SDIO1_REF_CTRL__SRCSEL	VPLL,IOPLL,RPLL	RPLL
	PSU__CRL__APB__UART0_REF_CTRL__SRCSEL	DPLL,IOPLL,RPLL	IOPLL
	PSU__CRL__APB__UART1_REF_CTRL__SRCSEL	DPLL,IOPLL,RPLL	IOPLL
	PSU__CRL__APB__I2C0_REF_CTRL__SRCSEL	DPLL,IOPLL,RPLL	IOPLL
	PSU__CRL__APB__I2C1_REF_CTRL__SRCSEL	DPLL,IOPLL,RPLL	IOPLL
	PSU__CRL__APB__SPI0_REF_CTRL__SRCSEL	DPLL,IOPLL,RPLL	RPLL

Table C-1: User Parameters (Cont'd)

Parameter Description	Parameters	Range	Default Values
Clocking related Parameters and Divisors (continued)	PSU__CRL_APB__SPI1_REF_CTRL__SRCSEL	DPLL,IOPLL,RPLL	RPLL
	PSU__CRL_APB__CAN0_REF_CTRL__SRCSEL	DPLL,IOPLL,RPLL	IOPLL
	PSU__CRL_APB__CAN1_REF_CTRL__SRCSEL	DPLL,IOPLL,RPLL	IOPLL
	PSU__CRL_APB__DEBUG_R5_ATCLK_CTRL__SRCSEL	RPLL,IOPLL,DPLL	RPLL
	PSU__CRL_APB__CPU_R5_CTRL__SRCSEL	IOPLL,RPLL,DPLL	RPLL
	PSU__CRL_APB__OCM_MAIN_CTRL__SRCSEL	IOPLL,RPLL,DPLL	IOPLL
	PSU__CRL_APB__IOU_SWITCH_CTRL__SRCSEL	IOPLL,RPLL,DPLL	RPLL
	PSU__CRL_APB__CSU_PLL_CTRL__SRCSEL	DPLL,IOPLL,RPLL,SysOsc	SysOsc
	PSU__CRL_APB__PCAP_CTRL__SRCSEL	DPLL,IOPLL,RPLL	RPLL
	PSU__CRL_APB__LPD_LSBUS_CTRL__SRCSEL	IOPLL,RPLL,DPLL	IOPLL
	PSU__CRL_APB__LPD_SWITCH_CTRL__SRCSEL	IOPLL,RPLL,DPLL	IOPLL
	PSU__CRL_APB__DBG_LPD_CTRL__SRCSEL	IOPLL,RPLL,DPLL	IOPLL
	PSU__CRL_APB__NAND_REF_CTRL__SRCSEL	DPLL,IOPLL,RPLL	IOPLL
	PSU__CRL_APB__ADMA_REF_CTRL__SRCSEL	RPLL,IOPLL,DPLL	IOPLL
	PSU__CRL_APB__DLL_REF_CTRL__SRCSEL	IOPLL,RPLL	IOPLL
	PSU__CRL_APB__AMS_REF_CTRL__SRCSEL	IOPLL,RPLL,DPLL	IOPLL
	PSU__CRL_APB__TIMESTAMP_REF_CTRL__SRCSEL	RPLL,IOPLL,DPLL	IOPLL
	PSU__CRL_APB__AFI6_REF_CTRL__SRCSEL	RPLL,IOPLL,DPLL	IOPLL
	PSU__CRL_APB__USB3_DUAL_REF_CTRL__SRCSEL	IOPLL,RPLL,DPLL	IOPLL
	PSU__IOU_SLCR__WDT_CLK_SELECT	APB,External	APB
PSU__FPD_SLCR__WDT_CLK_SELECT	APB,External	APB	

Table C-1: User Parameters (Cont'd)

Parameter Description	Parameters	Range	Default Values
Clocking related Parameters and Divisors (continued)	PSU__IOU_SLCR__IOU_TTC_APB_CLK__TTC0_SEL	APB,CPU_R5,PSS_REF_CLK	APB
	PSU__IOU_SLCR__IOU_TTC_APB_CLK__TTC1_SEL	APB,CPU_R5,PSS_REF_CLK	APB
	PSU__IOU_SLCR__IOU_TTC_APB_CLK__TTC2_SEL	APB,CPU_R5,PSS_REF_CLK	APB
	PSU__IOU_SLCR__IOU_TTC_APB_CLK__TTC3_SEL	APB,CPU_R5,PSS_REF_CLK	APB
	PSU__CRF_APB__APLL_FRAC_CFG__ENABLED	0,1	0
	PSU__CRF_APB__VPLL_FRAC_CFG__ENABLED	0,1	0
	PSU__CRF_APB__DPLL_FRAC_CFG__ENABLED	0,1	0
	PSU__CRL_APB__IOPLL_FRAC_CFG__ENABLED	0,1	0
	PSU__CRL_APB__RPLL_FRAC_CFG__ENABLED	0,1	0
	PSU__OVERRIDE__BASIC_CLOCK	0,1	0
	PSU__PL_CLK0_BUF	FALSE,TRUE	TRUE
	PSU__PL_CLK1_BUF	FALSE,TRUE	FALSE
	PSU__PL_CLK2_BUF	FALSE,TRUE	FALSE
	PSU__PL_CLK3_BUF	FALSE,TRUE	FALSE
	PSU__CRF_APB__APLL_CTRL__FRACFREQ		27.138
	PSU__CRF_APB__VPLL_CTRL__FRACFREQ		27.138
	PSU__CRF_APB__DPLL_CTRL__FRACFREQ		27.138
	PSU__CRL_APB__IOPLL_CTRL__FRACFREQ		27.138
	PSU__CRL_APB__RPLL_CTRL__FRACFREQ		27.138
	PSU__IOU_SLCR__TTC0__ACT_FREQMHZ	0.000000,600.000000	100
	PSU__IOU_SLCR__TTC1__ACT_FREQMHZ	0.000000,600.000000	100
	PSU__IOU_SLCR__TTC2__ACT_FREQMHZ	0.000000,600.000000	100
	PSU__IOU_SLCR__TTC3__ACT_FREQMHZ	600.000000,0.000000	100
	PSU__IOU_SLCR__WDT0__ACT_FREQMHZ	0.000000,100.000000	100
	PSU__FPD_SLCR__WDT1__ACT_FREQMHZ		100

Table C-1: User Parameters (Cont'd)

Parameter Description	Parameters	Range	Default Values
Clocking related Parameters and Divisors (continued)	PSU__CRF_APB__ACPU_CTRL__ACT_FREQMHZ		1199.988
	PSU__CRF_APB__DBG_TRACE_CTRL__ACT_FREQMHZ		249.997
	PSU__CRF_APB__DBG_FPD_CTRL__ACT_FREQMHZ		249.997
	PSU__CRF_APB__APM_CTRL__ACT_FREQMHZ		1
	PSU__CRF_APB__DP_VIDEO_REF_CTRL__ACT_FREQMHZ		320
	PSU__CRF_APB__DP_AUDIO_REF_CTRL__ACT_FREQMHZ		25
	PSU__CRF_APB__DP_STC_REF_CTRL__ACT_FREQMHZ		27
	PSU__CRF_APB__DDR_CTRL__ACT_FREQMHZ		374.996
	PSU__DDR__INTERFACE__FREQMHZ	0.000000,600.000000	400.00
	PSU__CRF_APB__GPU_REF_CTRL__ACT_FREQMHZ		499.995
	PSU__CRF_APB__AFI0_REF_CTRL__ACT_FREQMHZ		667
	PSU__CRF_APB__AFI1_REF_CTRL__ACT_FREQMHZ		667
	PSU__CRF_APB__AFI2_REF_CTRL__ACT_FREQMHZ		667
	PSU__CRF_APB__AFI3_REF_CTRL__ACT_FREQMHZ		667
	PSU__CRF_APB__AFI4_REF_CTRL__ACT_FREQMHZ		667
	PSU__CRF_APB__AFI5_REF_CTRL__ACT_FREQMHZ		667
	PSU__CRF_APB__SATA_REF_CTRL__ACT_FREQMHZ		250
	PSU__CRF_APB__PCIE_REF_CTRL__ACT_FREQMHZ		250
	PSU__CRL_APB__PL0_REF_CTRL__ACT_FREQMHZ		99.999
	PSU__CRL_APB__PL1_REF_CTRL__ACT_FREQMHZ		100
PSU__CRL_APB__PL2_REF_CTRL__ACT_FREQMHZ		100	

Table C-1: User Parameters (Cont'd)

Parameter Description	Parameters	Range	Default Values
Clocking related Parameters and Divisors (continued)	PSU__CRL_APB__PL3_REF_CTRL__ACT_FREQMHZ		100
	PSU__CRF_APB__GDMA_REF_CTRL__ACT_FREQMHZ		599.994
	PSU__CRF_APB__DPDMA_REF_CTRL__ACT_FREQMHZ		599.994
	PSU__CRF_APB__TOPSW_MAIN_CTRL__ACT_FREQMHZ		499.995
	PSU__CRF_APB__TOPSW_LSBUS_CTRL__ACT_FREQMHZ		99.999
	PSU__CRF_APB__GTGREF0_REF_CTRL__ACT_FREQMHZ		-1
	PSU__CRF_APB__DBG_TSTMP_CTRL__ACT_FREQMHZ		249.997
	PSU__CRL_APB__GEM0_REF_CTRL__ACT_FREQMHZ		125
	PSU__CRL_APB__GEM1_REF_CTRL__ACT_FREQMHZ		125
	PSU__CRL_APB__GEM2_REF_CTRL__ACT_FREQMHZ		125
	PSU__CRL_APB__GEM3_REF_CTRL__ACT_FREQMHZ		125
	PSU__CRL_APB__GEM_TSU_REF_CTRL__ACT_FREQMHZ		250
	PSU__CRL_APB__USB0_BUS_REF_CTRL__ACT_FREQMHZ		250
	PSU__CRL_APB__USB1_BUS_REF_CTRL__ACT_FREQMHZ		250
	PSU__CRL_APB__QSPI_REF_CTRL__ACT_FREQMHZ		300
	PSU__CRL_APB__SDIO0_REF_CTRL__ACT_FREQMHZ		200
	PSU__CRL_APB__SDIO1_REF_CTRL__ACT_FREQMHZ		200
	PSU__CRL_APB__UART0_REF_CTRL__ACT_FREQMHZ		100
	PSU__CRL_APB__UART1_REF_CTRL__ACT_FREQMHZ		100
	PSU__CRL_APB__I2C0_REF_CTRL__ACT_FREQMHZ		100

Table C-1: User Parameters (Cont'd)

Parameter Description	Parameters	Range	Default Values
Clocking related Parameters and Divisors (continued)	PSU__CRL_APB__I2C1_REF_CTRL__ACT_FREQMHZ		100
	PSU__CRL_APB__SPI0_REF_CTRL__ACT_FREQMHZ		214
	PSU__CRL_APB__SPI1_REF_CTRL__ACT_FREQMHZ		214
	PSU__CRL_APB__CAN0_REF_CTRL__ACT_FREQMHZ		100
	PSU__CRL_APB__CAN1_REF_CTRL__ACT_FREQMHZ		100
	PSU__CRL_APB__DEBUG_R5_ATCLK_CTRL__ACT_FREQMHZ		1000
	PSU__CRL_APB__CPU_R5_CTRL__ACT_FREQMHZ		499.995
	PSU__CRL_APB__OCM_MAIN_CTRL__ACT_FREQMHZ		500
	PSU__CRL_APB__IOU_SWITCH_CTRL__ACT_FREQMHZ		249.997
	PSU__CRL_APB__CSU_PLL_CTRL__ACT_FREQMHZ		180
	PSU__CRL_APB__PCAP_CTRL__ACT_FREQMHZ		249.997
	PSU__CRL_APB__LPD_LSBUS_CTRL__ACT_FREQMHZ		99.999
	PSU__CRL_APB__LPD_SWITCH_CTRL__ACT_FREQMHZ		499.995
	PSU__CRL_APB__DBG_LPD_CTRL__ACT_FREQMHZ		249.997
	PSU__CRL_APB__NAND_REF_CTRL__ACT_FREQMHZ		100
	PSU__CRL_APB__ADMA_REF_CTRL__ACT_FREQMHZ		499.995
	PSU__CRL_APB__DLL_REF_CTRL__ACT_FREQMHZ		1500
	PSU__CRL_APB__AMS_REF_CTRL__ACT_FREQMHZ		50
	PSU__CRL_APB__TIMESTAMP_REF_CTRL__ACT_FREQMHZ		99.999
	PSU__CRL_APB__AFI6_REF_CTRL__ACT_FREQMHZ		500

Table C-1: User Parameters (Cont'd)

Parameter Description	Parameters	Range	Default Values
Clocking related Parameters and Divisors (continued)	PSU__CRL_APB__USB3_DUAL_REF_CTRL__ACT_FREQMHZ		20
	PSU__CRF_APB__ACPU_CTRL__FREQMHZ	0.000000,1500.000000	1200
	PSU__CRF_APB__DBG_TRACE_CTRL__FREQMHZ	0.000000,250.000000	250
	PSU__CRF_APB__DBG_FPD_CTRL__FREQMHZ	0.000000,250.000000	250
	PSU__CRF_APB__APM_CTRL__FREQMHZ	-2,-1	1
	PSU__CRF_APB__DP_VIDEO_REF_CTRL__FREQMHZ	0.000000,320.000000	320
	PSU__CRF_APB__DP_AUDIO_REF_CTRL__FREQMHZ	0.000000,25.000000	25
	PSU__CRF_APB__DP_STC_REF_CTRL__FREQMHZ	0.000000,27.000000	27
	PSU__CRF_APB__DDR_CTRL__FREQMHZ	100.000000,667.000000	800
	PSU__CRF_APB__GPU_REF_CTRL__FREQMHZ	0.000000,667.000000	500
	PSU__CRF_APB__AFI0_REF_CTRL__FREQMHZ	0.000000,667.000000	667
	PSU__CRF_APB__AFI1_REF_CTRL__FREQMHZ	0.000000,667.000000	667
	PSU__CRF_APB__AFI2_REF_CTRL__FREQMHZ	0.000000,667.000000	667
	PSU__CRF_APB__AFI3_REF_CTRL__FREQMHZ	0.000000,667.000000	667
	PSU__CRF_APB__AFI4_REF_CTRL__FREQMHZ	0.000000,667.000000	667
	PSU__CRF_APB__AFI5_REF_CTRL__FREQMHZ	0.000000,667.000000	667
	PSU__CRF_APB__SATA_REF_CTRL__FREQMHZ	0.000000,250.000000	250
	PSU__CRF_APB__PCIE_REF_CTRL__FREQMHZ	0.000000,250.000000	250
	PSU__CRL_APB__PL0_REF_CTRL__FREQMHZ	0.000000,400.000000	100
	PSU__CRL_APB__PL1_REF_CTRL__FREQMHZ	0.000000,400.000000	100
PSU__CRL_APB__PL2_REF_CTRL__FREQMHZ	0.000000,400.000000	100	

Table C-1: User Parameters (Cont'd)

Parameter Description	Parameters	Range	Default Values
Clocking related Parameters and Divisors (continued)	PSU__CRL_APB__PL3_REF_CTRL__FREQMHZ	0.000000,400.000000	100
	PSU__CRF_APB__GDMA_REF_CTRL__FREQMHZ	0.000000,667.000000	600
	PSU__CRF_APB__DPDMA_REF_CTRL__FREQMHZ	0.000000,667.000000	600
	PSU__CRF_APB__TOPSW_MAIN_CTRL__FREQMHZ	0.000000,600.000000	533.33
	PSU__CRF_APB__TOPSW_LSBUS_CTRL__FREQMHZ	0.000000,100.000000	100
	PSU__CRF_APB__GTGREF0_REF_CTRL__FREQMHZ	-2,-1	-1
	PSU__CRF_APB__DBG_TSTMP_CTRL__FREQMHZ	0.000000,250.000000	250
	PSU__CRL_APB__GEM0_REF_CTRL__FREQMHZ	0.000000,125.000000	125
	PSU__CRL_APB__GEM1_REF_CTRL__FREQMHZ	0.000000,125.000000	125
	PSU__CRL_APB__GEM2_REF_CTRL__FREQMHZ	0.000000,125.000000	125
	PSU__CRL_APB__GEM3_REF_CTRL__FREQMHZ	0.000000,125.000000	125
	PSU__CRL_APB__GEM_TSU_REF_CTRL__FREQMHZ	0.000000,250.000000	250
	PSU__CRL_APB__USB0_BUS_REF_CTRL__FREQMHZ	0.000000,250.000000	250
	PSU__CRL_APB__USB1_BUS_REF_CTRL__FREQMHZ	0.000000,250.000000	250
	PSU__CRL_APB__QSPI_REF_CTRL__FREQMHZ	0.000000,300.000000	300
	PSU__CRL_APB__SDIO0_REF_CTRL__FREQMHZ	0.000000,200.000000	200
	PSU__CRL_APB__SDIO1_REF_CTRL__FREQMHZ	0.000000,200.000000	200
	PSU__CRL_APB__UART0_REF_CTRL__FREQMHZ	0.000000,100.000000	100
	PSU__CRL_APB__UART1_REF_CTRL__FREQMHZ	0.000000,100.000000	100
	PSU__CRL_APB__I2C0_REF_CTRL__FREQMHZ	0.000000,100.000000	100

Table C-1: User Parameters (Cont'd)

Parameter Description	Parameters	Range	Default Values
Clocking related Parameters and Divisors (continued)	PSU__CRL_APB__I2C1_REF_CTRL__FREQMHZ	0.000000,100.000000	100
	PSU__CRL_APB__SPI0_REF_CTRL__FREQMHZ	0.000000,200.000000	200
	PSU__CRL_APB__SPI1_REF_CTRL__FREQMHZ	0.000000,200.000000	200
	PSU__CRL_APB__CAN0_REF_CTRL__FREQMHZ	0.000000,100.000000	100
	PSU__CRL_APB__CAN1_REF_CTRL__FREQMHZ	0.000000,100.000000	100
	PSU__CRL_APB__DEBUG_R5_ATCLK_CTRL__FREQMHZ	0.000000,1000.000000	1000
	PSU__CRL_APB__CPU_R5_CTRL__FREQMHZ	0.000000,600.000000	500
	PSU__CRL_APB__OCM_MAIN_CTRL__FREQMHZ	0.000000,600.000000	500
	PSU__CRL_APB__IOU_SWITCH_CTRL__FREQMHZ	0.000000,267.000000	267
	PSU__CRL_APB__CSU_PLL_CTRL__FREQMHZ	0.000000,400.000000	180
	PSU__CRL_APB__PCAP_CTRL__FREQMHZ	0.000000,250.000000	250
	PSU__CRL_APB__LPD_LSBUS_CTRL__FREQMHZ	0.000000,100.000000	100
	PSU__CRL_APB__LPD_SWITCH_CTRL__FREQMHZ	0.000000,600.000000	500
	PSU__CRL_APB__DBG_LPD_CTRL__FREQMHZ	0.000000,267.000000	250
	PSU__CRL_APB__NAND_REF_CTRL__FREQMHZ	0.000000,100.000000	100
	PSU__CRL_APB__ADMA_REF_CTRL__FREQMHZ	0.000000,600.000000	500
	PSU__CRL_APB__DLL_REF_CTRL__FREQMHZ	0.000000,1500.000000	1500
	PSU__CRL_APB__AMS_REF_CTRL__FREQMHZ	0.000000,52.000000	50
	PSU__CRL_APB__TIMESTAMP_REF_CTRL__FREQMHZ	0.000000,100.000000	100
	PSU__CRL_APB__AFI6_REF_CTRL__FREQMHZ	0.000000,600.000000	500
PSU__CRL_APB__USB3_DUAL_REF_CTRL__FREQMHZ	0.000000,20.000000	20	

Table C-1: User Parameters (Cont'd)

Parameter Description	Parameters	Range	Default Values
Clocking related Parameters and Divisors (continued)	PSU__IOU_SLCR__TTC0__FREQMHZ	0.000000,600.000000	100
	PSU__IOU_SLCR__TTC1__FREQMHZ	0.000000,600.000000	100
	PSU__IOU_SLCR__TTC2__FREQMHZ	0.000000,600.000000	100
	PSU__IOU_SLCR__TTC3__FREQMHZ	0.000000,600.000000	100
	PSU__IOU_SLCR__WDT0__FREQMHZ	0.000000,100.000000	100
	PSU__FPD_SLCR__WDT1__FREQMHZ	0.000000,100.000000	100
CSU Tamper Enable	PSU__CSU__CSU_TAMPER_0__ENABLE	0,1	0
	PSU__CSU__CSU_TAMPER_1__ENABLE	0,1	0
	PSU__CSU__CSU_TAMPER_2__ENABLE	0,1	0
	PSU__CSU__CSU_TAMPER_3__ENABLE	0,1	0
	PSU__CSU__CSU_TAMPER_4__ENABLE	0,1	0
	PSU__CSU__CSU_TAMPER_5__ENABLE	0,1	0
	PSU__CSU__CSU_TAMPER_6__ENABLE	0,1	0
	PSU__CSU__CSU_TAMPER_7__ENABLE	0,1	0
	PSU__CSU__CSU_TAMPER_8__ENABLE	0,1	0
	PSU__CSU__CSU_TAMPER_9__ENABLE	0,1	0
	PSU__CSU__CSU_TAMPER_10__ENABLE	0,1	0
	PSU__CSU__CSU_TAMPER_11__ENABLE	0,1	0
PSU__CSU__CSU_TAMPER_12__ENABLE	0,1	0	
CSU Tamper Erase block RAM	PSU__CSU__CSU_TAMPER_0__ERASE_BBRAM	0,1	0
	PSU__CSU__CSU_TAMPER_1__ERASE_BBRAM	0,1	0
	PSU__CSU__CSU_TAMPER_2__ERASE_BBRAM	0,1	0
	PSU__CSU__CSU_TAMPER_3__ERASE_BBRAM	0,1	0
	PSU__CSU__CSU_TAMPER_4__ERASE_BBRAM	0,1	0
	PSU__CSU__CSU_TAMPER_5__ERASE_BBRAM	0,1	0
	PSU__CSU__CSU_TAMPER_6__ERASE_BBRAM	0,1	0
	PSU__CSU__CSU_TAMPER_7__ERASE_BBRAM	0,1	0
PSU__CSU__CSU_TAMPER_8__ERASE_BBRAM	0,1	0	

Table C-1: User Parameters (Cont'd)

Parameter Description	Parameters	Range	Default Values
CSU Tamper Erase block RAM (continued)	PSU__CSU__CSU_TAMPER_9__ERASE_BBAM	0,1	0
	PSU__CSU__CSU_TAMPER_10__ERASE_BBAM	0,1	0
	PSU__CSU__CSU_TAMPER_11__ERASE_BBAM	0,1	0
	PSU__CSU__CSU_TAMPER_12__ERASE_BBAM	0,1	0

Table C-1: User Parameters (Cont'd)

Parameter Description	Parameters	Range	Default Values
CSU Tamper Response	PSU__CSU__CSU_TAMPER_0__RESPONSE	<Select>,SEC_LOCKDOWN_N_0, SEC_LOCKDOWN_1,SYS_RESET, SYS_INTERRUPT	<Select>
	PSU__CSU__CSU_TAMPER_1__RESPONSE	<Select>,SEC_LOCKDOWN_N_0, SEC_LOCKDOWN_1,SYS_RESET, SYS_INTERRUPT	<Select>
	PSU__CSU__CSU_TAMPER_2__RESPONSE	<Select>,SEC_LOCKDOWN_N_0, SEC_LOCKDOWN_1,SYS_RESET, SYS_INTERRUPT	<Select>
	PSU__CSU__CSU_TAMPER_3__RESPONSE	<Select>,SEC_LOCKDOWN_N_0, SEC_LOCKDOWN_1,SYS_RESET, SYS_INTERRUPT	<Select>
	PSU__CSU__CSU_TAMPER_4__RESPONSE	<Select>,SEC_LOCKDOWN_N_0, SEC_LOCKDOWN_1,SYS_RESET, SYS_INTERRUPT	<Select>
	PSU__CSU__CSU_TAMPER_5__RESPONSE	<Select>,SEC_LOCKDOWN_N_0, SEC_LOCKDOWN_1,SYS_RESET, SYS_INTERRUPT	<Select>
	PSU__CSU__CSU_TAMPER_6__RESPONSE	<Select>,SEC_LOCKDOWN_N_0, SEC_LOCKDOWN_1,SYS_RESET, SYS_INTERRUPT	<Select>
	PSU__CSU__CSU_TAMPER_7__RESPONSE	<Select>,SEC_LOCKDOWN_N_0, SEC_LOCKDOWN_1,SYS_RESET, SYS_INTERRUPT	<Select>
	PSU__CSU__CSU_TAMPER_8__RESPONSE	<Select>,SEC_LOCKDOWN_N_0, SEC_LOCKDOWN_1,SYS_RESET, SYS_INTERRUPT	<Select>
	PSU__CSU__CSU_TAMPER_9__RESPONSE	<Select>,SEC_LOCKDOWN_N_0, SEC_LOCKDOWN_1,SYS_RESET, SYS_INTERRUPT	<Select>

Table C-1: User Parameters (Cont'd)

Parameter Description	Parameters	Range	Default Values
CSU Tamper Response (continued)	PSU__CSU__CSU_TAMPER_12__RESPONSE	<Select>,SEC_LOCKDOWN_0, SEC_LOCKDOWN_1,SYS_RESET, SYS_INTERRUPT	<Select>
IPI Master	PSU__GEN_IPI_0__MASTER	NONE,APU,RPU0,RPU1, S_AXI_HP1_FPD,S_AXI_HP2_FPD, S_AXI_HP3_FPD,S_AXI_LPD, S_AXI_HP0_FPD, S_AXI_HPC0_FPD,S_AXI_HPC1_FPD, S_AXI_ACP_FPD	APU
	PSU__GEN_IPI_1__MASTER	NONE,APU,RPU0,RPU1, S_AXI_HP1_FPD,S_AXI_HP2_FPD, S_AXI_HP3_FPD,S_AXI_LPD, S_AXI_HP0_FPD, S_AXI_HPC0_FPD,S_AXI_HPC1_FPD, S_AXI_ACP_FPD	RPU0
	PSU__GEN_IPI_2__MASTER	NONE,APU,RPU0,RPU1, S_AXI_HP1_FPD,S_AXI_HP2_FPD, S_AXI_HP3_FPD,S_AXI_LPD, S_AXI_HP0_FPD, S_AXI_HPC0_FPD,S_AXI_HPC1_FPD, S_AXI_ACP_FPD	RPU1
	PSU__GEN_IPI_3__MASTER	NONE,PMU	PMU
	PSU__GEN_IPI_4__MASTER	NONE,PMU	PMU
	PSU__GEN_IPI_5__MASTER	NONE,PMU	PMU
	PSU__GEN_IPI_6__MASTER	NONE,PMU	PMU
	PSU__GEN_IPI_7__MASTER	NONE,APU,RPU0,RPU1, S_AXI_HP1_FPD,S_AXI_HP2_FPD, S_AXI_HP3_FPD,S_AXI_LPD, S_AXI_HP0_FPD, S_AXI_HPC0_FPD,S_AXI_HPC1_FPD, S_AXI_ACP_FPD	NONE
	PSU__GEN_IPI_8__MASTER	NONE,APU,RPU0,RPU1, S_AXI_HP1_FPD,S_AXI_HP2_FPD, S_AXI_HP3_FPD,S_AXI_LPD, S_AXI_HP0_FPD, S_AXI_HPC0_FPD,S_AXI_HPC1_FPD, S_AXI_ACP_FPD	NONE

Table C-1: User Parameters (Cont'd)

Parameter Description	Parameters	Range	Default Values
	PSU__GEN_IPI_9__MASTER	NONE,APU,RPU0,RPU1, S_AXI_HP1_FPD,S_AXI_HP2_FPD, S_AXI_HP3_FPD,S_AXI_LPD, S_AXI_HP0_FPD, S_AXI_HPC0_FPD,S_AXI_HPC1_FPD, S_AXI_ACP_FPD	NONE

Table C-1: User Parameters (Cont'd)

Parameter Description	Parameters	Range	Default Values
	PSU__GEN_IPI_10__MASTER	NONE,APU,RPU0,RPU1,S_AXI_HP1_FPD,S_AXI_HP2_FPD,S_AXI_HP3_FPD,S_AXI_LPD,S_AXI_HPO_FPD,S_AXI_HPC0_FPD,S_AXI_HPC1_FPD,S_AXI_ACP_FPD	NONE
	PSU__NUM_FABRIC_RESETS	0,1,2,3,4	1
	PSU__GPIO_EMIO__WIDTH	NA	[94:0]
	PSU__REPORT__DBGLOG	0,1	0

Notes:

- Reserve, Wireless controller, Satellite communication controller, Data acquisition and signal processing controllers, Intelligent I/O controllers, Docking stations, Device was built before Class Code definitions were finalized, Memory controller, Simple communication controller, Serial bus controllers, Encryption/Decryption controller, Display controller, Multimedia device, Input devices, Mass storage controller, Processors, Device does not fit in any defined classes, Bridge device, Network controller, Base system peripherals, Multimedia device
- ADMA is also referenced as LPD_DMA throughout this guide. These two terms are synonymous.
- GDMA is also referenced as FPD_DMA throughout this guide. These two terms are synonymous.

Table C-2: PSU__PROTECTION__MASTERS Default Values

Default Values		
USB1:NonSecure;0	USB0:NonSecure;0	S_AXI_LPD:NA;0
S_AXI_HPC1_FPD:NA;0	S_AXI_HPC0_FPD:NA;0	S_AXI_HP3_FPD:NA;0
S_AXI_HP2_FPD:NA;0	S_AXI_HP1_FPD:NA;0	S_AXI_HPO_FPD:NA;0
S_AXI_ACP:NA;0	S_AXI_ACE:NA;0	SD1:Secure;0
SD0:Secure;0	SATA1:NonSecure;0	SATA0:NonSecure;0
RPU1:Secure;1	RPU0:Secure;1	QSPI:Secure;0
PMU:NA;1	PCIe:NonSecure;0	NAND:Secure;0
LDMA:NA;1	GPU:Secure;1	GEM3:Secure;0
GEM2:Secure;0	GEM1:Secure;0	GEM0:Secure;0
FDMA:NA;1	DP:NonSecure;0	DAP:NA;1'
Coresight:NA;1	CSU:NA;1	APU:NA;1

Table C-3: PSU__PROTECTION__SLAVES

Default Values		
LPD;USB3_1_XHCI;FE300000;FE3FFFFFF;0	LPD;USB3_1;FF9E0000;FF9EFFFF;0	LPD;USB3_0_XHCI;FE200000;FE2FFFFFF;0
LPD;USB3_0;FF9D0000;FF9DFFFF;0	LPD;UART1;FF010000;FF01FFFF;0	LPD;UART0;FF000000;FF00FFFF;0
LPD;TTC3;FF140000;FF14FFFF;0	LPD;TTC2;FF130000;FF13FFFF;0	LPD;TTC1;FF120000;FF12FFFF;0
LPD;TTC0;FF110000;FF11FFFF;0	FPD;SWDT1;FD4D0000;FD4DFFFF;0	LPD;SWDT0;FF150000;FF15FFFF;0
LPD;SPI1;FF050000;FF05FFFF;0	LPD;SPI0;FF040000;FF04FFFF;0	FPD;SMMU_REG;FD5F0000;FD5FFFFFF;1
FPD;SMMU;FD800000;FDFFFFFF;1	FPD;SI0U;FD3D0000;FD3DFFFF;1	FPD;SERDES;FD400000;FD47FFFF;1
LPD;SD1;FF170000;FF17FFFF;0	LPD;SD0;FF160000;FF16FFFF;0	FPD;SATA;FD0C0000;FD0CFFFF;0
LPD;RTC;FFA60000;FFA6FFFF;1	LPD;RSA_CORE;FFCE0000;FFCEFFFF;1	LPD;RPU;FF9A0000;FF9AFFFF;1
FPD;RCPU_GIC;F9000000;F900FFFF;1	LPD;R5_TCM_RAM_GLOBAL;FFE00000;FFE3FFFF;1	LPD;R5_1_Instruction_Cache;FFEC0000;FFECFFFF;1
LPD;R5_1_Data_Cache;FFED0000;FFEDFFFF;1	LPD;R5_1_BTCM_GLOBAL;FFEB0000;FFEBFFFF;1	LPD;R5_1_ATCM_GLOBAL;FFE90000;FFE9FFFF;1
LPD;R5_0_Instruction_Cache;FFE40000;FFE4FFFF;1	LPD;R5_0_Data_Cache;FFE50000;FFE5FFFF;1	LPD;R5_0_BTCM_GLOBAL;FFE20000;FFE2FFFF;1
LPD;R5_0_ATCM_GLOBAL;FFE00000;FFE0FFFF;1	LPD;QSPI_Linear_Address;C0000000;DFFFFFFF;1	LPD;QSPI;FF0F0000;FF0FFFFFF;0
LPD;PMU_RAM;FFDC0000;FFDDFFFF;1	LPD;PMU_GLOBAL;FFD80000;FFDBFFFF;1	FPD;PCIE_MAIN;FD0E0000;FD0EFFFF;0
FPD;PCIE_LOW;E0000000;EFFFFFFF;0	FPD;PCIE_HIGH;600000000;7FFFFFFF;0	FPD;PCIE_DMA;FD0F0000;FD0FFFFFF;0
FPD;PCIE_ATTRIB;FD480000;FD48FFFF;0	LPD;OCM_XMPU_CFG;FFA70000;FFA7FFFF;1	LPD;OCM_SLCR;FF960000;FF96FFFF;1
OCM;OCM;FFFC0000;FFFFFFF;1	LPD;NAND;FF100000;FF10FFFF;0	LPD;MBISTJTAG;FFCF0000;FFCFFFFF;1
LPD;LPD_XPPU_SINK;FF9C0000;FF9CFFFF;1	LPD;LPD_XPPU;FF980000;FF98FFFF;1	LPD;LPD_SLCR_SECURE;FF4B0000;FF4DFFFF;1
LPD;LPD_SLCR;FF410000;FF4AFFFF;1	LPD;LPD_GPV;FE100000;FE1FFFFFF;1	LPD;LPD_DMA_7;FFAF0000;FFAFFFFFF;1
LPD;LPD_DMA_6;FFAE0000;FFAEFFFF;1	LPD;LPD_DMA_5;FFAD0000;FFADFFFF;1	LPD;LPD_DMA_4;FFAC0000;FFACFFFF;1
LPD;LPD_DMA_3;FFAB0000;FFABFFFF;1	LPD;LPD_DMA_2;FFAA0000;FFAAFFFF;1	LPD;LPD_DMA_1;FFA90000;FFA9FFFF;1
LPD;LPD_DMA_0;FFA80000;FFA8FFFF;1	LPD;IPI_CTRL;FF380000;FF3FFFFFF;1	LPD;IOU_SLCR;FF180000;FF23FFFF;1

Table C-3: PSU__PROTECTION__SLAVES (Cont'd)

Default Values		
LPD;IOU_SECURE_SLCR;FF240000;FF24FFFF;1	LPD;IOU_SCNTRS;FF260000;FF26FFFF;1	LPD;IOU_SCNTR;FF250000;FF25FFFF;1
LPD;IOU_GPV;FE000000;FE0FFFFFF;1	LPD;I2C1;FF030000;FF03FFFF;0	LPD;I2C0;FF020000;FF02FFFF;0
FPD;GPU;FD4B0000;FD4BFFFF;1	LPD;GPIO;FF0A0000;FF0AFFFF;1	LPD;GEM3;FF0E0000;FF0EFFFF;0
LPD;GEM2;FF0D0000;FF0DFFFF;0	LPD;GEM1;FF0C0000;FF0CFFFF;0	LPD;GEM0;FF0B0000;FF0BFFFF;0
FPD;FPD_XMPU_SINK;FD4F0000;FD4FFFFF;1	FPD;FPD_XMPU_CFG;FD5D0000;FD5DFFFF;1	FPD;FPD_SLCR_SECURE;FD690000;FD6CFFFF;1
FPD;FPD_SLCR;FD610000;FD68FFFF;1	FPD;FPD_GPV;FD700000;FD7FFFFFF;1	FPD;FPD_DMA_CH7;FD570000;FD57FFFF;1
FPD;FPD_DMA_CH6;FD560000;FD56FFFF;1	FPD;FPD_DMA_CH5;FD550000;FD55FFFF;1	FPD;FPD_DMA_CH4;FD540000;FD54FFFF;1
FPD;FPD_DMA_CH3;FD530000;FD53FFFF;1	FPD;FPD_DMA_CH2;FD520000;FD52FFFF;1	FPD;FPD_DMA_CH1;FD510000;FD51FFFF;1
FPD;FPD_DMA_CH0;FD500000;FD50FFFF;1	LPD;EFUSE;FFCC0000;FFCCFFFF;1	FPD;Display Port;FD4A0000;FD4AFFFF;0
FPD;DPDMA;FD4C0000;FD4CFFFF;1	FPD;DDR_XMPU5_CFG;FD050000;FD05FFFF;1	FPD;DDR_XMPU4_CFG;FD040000;FD04FFFF;1
FPD;DDR_XMPU3_CFG;FD030000;FD03FFFF;1	FPD;DDR_XMPU2_CFG;FD020000;FD02FFFF;1	FPD;DDR_XMPU1_CFG;FD010000;FD01FFFF;1
FPD;DDR_XMPU0_CFG;FD000000;FD00FFFF;1	FPD;DDR_QOS_CTRL;FD090000;FD09FFFF;1	FPD;DDR_PHY;FD080000;FD08FFFF;1
DDR;DDR_LOW;0;7FFFFFFF;1	DDR;DDR_HIGH;800000000;800000000;0	FPD;DDDR_CTRL;FD070000;FD070FFF;1
LPD;Coresight;FE800000;FEFFFFFF;1	LPD;CSU_DMA;FFC80000;FFC9FFFF;1	LPD;CSU;FFCA0000;FFCAFFFF;0
LPD;CRL_APB;FF5E0000;FF85FFFF;1	FPD;CRF_APB;FD1A0000;FD2DFFFF;1	FPD;CCI_REG;FD5E0000;FD5EFFFF;1
FPD;CCI_GPV;FD6E0000;FD6EFFFF;1	LPD;CAN1;FF070000;FF07FFFF;0	LPD;CAN0;FF060000;FF06FFFF;0
FPD;APU;FD5C0000;FD5CFFFF;1	LPD;APM_INTC_IOU;FFA20000;FFA2FFFF;1	LPD;APM_FPD_LPD;FFA30000;FFA3FFFF;1
FPD;APM_5;FD490000;FD49FFFF;1	FPD;APM_0;FD0B0000;FD0BFFFF;1	LPD;APM2;FFA10000;FFA1FFFF;1
LPD;APM1;FFA00000;FFA0FFFF;1	LPD;AMS;FFA50000;FFA5FFFF;1	FPD;AFI_5;FD3B0000;FD3BFFFF;1
FPD;AFI_4;FD3A0000;FD3AFFFF;1	FPD;AFI_3;FD390000;FD39FFFF;1	FPD;AFI_2;FD380000;FD38FFFF;1
FPD;AFI_1;FD370000;FD37FFFF;1	FPD;AFI_0;FD360000;FD36FFFF;1	LPD;AFIFM6;FF9B0000;FF9BFFFF;1
FPD;ACPU_GIC;F9000000;F907FFFF;1		

Debugging

This appendix includes details about resources available on the Xilinx Support website and debugging tools.

Finding Help on Xilinx.com

To help in the design and debug process when using the Zynq® UltraScale+™ MPSoC Processing System, the [Xilinx Support web page](#) contains key resources such as product documentation, release notes, answer records, information about known issues, and links for obtaining further product support.

Documentation

This product guide is the main document associated with the core. This guide, along with documentation related to all products that aid in the design process, can be found on the [Xilinx Support web page](#) or by using the Xilinx® Documentation Navigator.

Download the Xilinx Documentation Navigator from the [Downloads page](#). For more information about this tool and the features available, open the online help after installation.

Solution Centers

See the [Xilinx Solution Centers](#) for support on devices, software tools, and intellectual property at all stages of the design cycle. Topics include design assistance, advisories, and troubleshooting tips.

Answer Records

Answer Records include information about commonly encountered problems, helpful information on how to resolve these problems, and any known issues with a Xilinx product. Answer Records are created and maintained daily ensuring that users have access to the most accurate information available.

Answer Records for this core can also be located by using the Search Support box on the main [Xilinx support web page](#). To maximize your search results, use proper keywords such as

- Product name
- Tool message(s)
- Summary of the issue encountered

A filter search is available after results are returned to further target the results.

Master Answer Record for the Zynq UltraScale MPSoC Processing System

AR: [66183](#)

Technical Support

Xilinx provides technical support at the [Xilinx Support web page](#) for this LogiCORE™ IP product when used as described in the product documentation. Xilinx cannot guarantee timing, functionality, or support if you do any of the following:

- Implement the solution in devices that are not defined in the documentation.
- Customize the solution beyond that allowed in the product documentation.
- Change any section of the design labeled DO NOT MODIFY.

To contact Xilinx Technical Support, navigate to the [Xilinx Support web page](#).

Additional Resources and Legal Notices

Xilinx Resources

For support resources such as Answers, Documentation, Downloads, and Forums, see [Xilinx Support](#).

Documentation Navigator and Design Hubs

Xilinx® Documentation Navigator provides access to Xilinx documents, videos, and support resources, which you can filter and search to find information. To open the Xilinx Documentation Navigator (DocNav):

- From the Vivado® IDE, select **Help > Documentation and Tutorials**.
- On Windows, select **Start > All Programs > Xilinx Design Tools > DocNav**.
- At the Linux command prompt, enter `docnav`.

Xilinx® Design Hubs provide links to documentation organized by design tasks and other topics, which you can use to learn key concepts and address frequently asked questions. To access the Design Hubs:

- In the Xilinx Documentation Navigator, click the **Design Hubs View** tab.
- On the Xilinx website, see the [Design Hubs](#) page.

Note: For more information on Documentation Navigator, see the [Documentation Navigator](#) page on the Xilinx website.

References

These documents provide supplemental material useful with this product guide:

1. *Zynq UltraScale All Programmable MPSoC Technical Reference Manual* ([UG1085](#))
2. *Zynq UltraScale+ MPSoC Register Reference* ([UG1087](#)).
3. *Vivado Design Suite User Guide: Designing IP Subsystems using IP Integrator* ([UG994](#))
4. *Vivado Design Suite User Guide: Designing with IP* ([UG896](#))
5. *Vivado Design Suite User Guide: Getting Started* ([UG910](#))
6. *Vivado Design Suite User Guide: Programming and Debugging* ([UG908](#))
7. [AMBA AXI4-Stream Protocol Specification](#)
8. *DDR3L SDRAM Data Sheet* ([PDF location -- Micron Technology Inc.](#))
9. *UltraScale Devices Gen3 Integrated Block for PCI Express LogiCORE IP Product Guide* ([PG156](#))
10. *Zynq UltraScale+ All Programmable MPSoC Verification IP Data Sheet* ([DS941](#))

Revision History

The following table shows the revision history for this document.

Date	Version	Revision
10/04/2017	3.1	<ul style="list-style-type: none"> • Updated signal range for signal Number 1 in Table 2-2. • Updated signals in Connectivity section in Chapter 2. • Added Fractional Clocking and Load DDR Presets sections to Chapter 4. • Updated Speed Bin option in DDR Memory Options in Chapter 4. • Updated Figures 4-1, 4-7, 4-9, and 4-10. • Added ten new options to the Other Options section in Chapter 4. • Updated Notice of Disclaimer and added Automotive Applications Disclaimer. • Added Preset Support section to Chapter 4. • Added new table for TSU signals in Appendix B. • Removed CONFIG. from several of the Parameters in Table C-1. • Removed SME parameters from Table C-1.
04/05/2017	3.0	<ul style="list-style-type: none"> • Updated all the PCW screens as per the new look and feel changes in current Vivado IDE. • Updated Isolation settings configuration information in Chapter 4. • Updated clocking details of Output Clocks section in Chapter 4. • LPD_DMA (ADMA) and FPD_DMA(GDMA) signal names have been standardized across the guide.
11/30/2016	2.0	<ul style="list-style-type: none"> • Updated Figure 4-7 and Figure 5-1. • Removed ECC Scrub from page 35. • Added I/O Configuration table to Appendix D, Port Descriptions. • Changed many port names in Appendix B, Port Descriptions. See Appendix A, Migrating and Updating for details.
10/05/2016	2.0	<ul style="list-style-type: none"> • Added Updated all screen displays in Chapter 4. • Updated the GT Lane clocking description in Chapter 4. • Updated most of the DDR Configuration section in Chapter 4. • Added the PCIe Configuration and Isolation Configurations in PCW sections in Chapter 4. • Replaced User Parameters table in Appendix C.

Date	Version	Revision
06/08/2016	1.2	<ul style="list-style-type: none"> • Updated Figures 4-2 through 4-7. • Changed all _t_n signals to _t and removed the word "INVERTED" from the descriptions. • Modified PSU_CAN0_PERIPHERAL_ENABLE and PSU_CAN1_PERIPHERAL_ENABLE parameter default to be 0. • Removed PSU_DPAUX_PERIPHERAL_ENABLE parameter. • Updated the possible values for the PSU_DPAUX_PERIPHERAL_IO, PSU_SD1_SPEED_MODE, and PSU_CRF_APB_TOPSW_MAIN_CTRL_FREQMHZ parameters. • Added the PSU__DISPLAYPORT__PERIPHERAL__ENABLE and PSU__DP__LANE_SEL parameters. • Modified "Gpio" to be "GPIO" • Updated many of the rows that were missing information in Table C-1.
04/06/2016	1.1	<ul style="list-style-type: none"> • Added High Speed SerDes configuration feature. • Renamed "Unsupported Features" section as "Unsupported Features and Known Limitations." Removed all of the bulleted items. Added cross reference to the master answer record. • Removed ACP Transaction Checker section. • Removed NOR flash. • Updated AXI4 I/O Compliant Interfaces section. • Added data to Table 2-2, Device Utilization – Zynq UltraScale+ MPSoC. • Removed MicroBlaze information from the General Design Guidelines section. • Added or updated all screen displays in Chapter 4. • Replaced Drive 0 and Drive 1 fields with Drive Strength field. • Replaced Pull Enable and Pullup fields with Pull Type field • Added information about MIO and EMIO, Number of MIOs and their organization in the banks • Added brief details about SerDes configuration supported in PCW. • Added information about MIO Voltage standard; specified that the default voltage for the banks will be LVCMOM33 • Replaced Input Frequency field with Requested Freq (MHz). • Replaced Actual Frequency field with Actual Frequency (MHz). • Replaced Range with Range (MHz). • Added details about Cross Domain PLL, GT lane clocking, and Auto Vs Manual features.
11/18/2015	1.0	Initial version for public access.

Notice of Disclaimer

The information disclosed to you hereunder (the "Materials") is provided solely for the selection and use of Xilinx products. To the maximum extent permitted by applicable law: (1) Materials are made available "AS IS" and with all faults, Xilinx hereby DISCLAIMS ALL WARRANTIES AND CONDITIONS, EXPRESS, IMPLIED, OR STATUTORY, INCLUDING BUT NOT LIMITED TO WARRANTIES OF MERCHANTABILITY, NON-INFRINGEMENT, OR FITNESS FOR ANY PARTICULAR PURPOSE; and (2) Xilinx shall not be liable (whether in contract or tort, including negligence, or under any other theory of liability) for any loss or damage of any kind or nature related to, arising under, or in connection with, the Materials (including your use of the Materials), including for any direct, indirect, special, incidental, or consequential loss or damage (including loss of data, profits, goodwill, or any type of loss or damage suffered as a result of any action brought by a third party) even if such damage or loss was reasonably foreseeable or Xilinx had been advised of the possibility of the same. Xilinx assumes no obligation to correct any errors contained in the Materials or to notify you of updates to the Materials or to product specifications. You may not reproduce, modify, distribute, or publicly display the Materials without prior written consent. Certain products are subject to the terms and conditions of Xilinx's limited warranty, please refer to Xilinx's Terms of Sale which can be viewed at <https://www.xilinx.com/legal.htm#tos>; IP cores may be subject to warranty and support terms contained in a license issued to you by Xilinx. Xilinx products are not designed or intended to be fail-safe or for use in any application requiring fail-safe performance; you assume sole risk and liability for use of Xilinx products in such critical applications, please refer to Xilinx's Terms of Sale which can be viewed at <https://www.xilinx.com/legal.htm#tos>.

AUTOMOTIVE APPLICATIONS DISCLAIMER

AUTOMOTIVE PRODUCTS (IDENTIFIED AS "XA" IN THE PART NUMBER) ARE NOT WARRANTED FOR USE IN THE DEPLOYMENT OF AIRBAGS OR FOR USE IN APPLICATIONS THAT AFFECT CONTROL OF A VEHICLE ("SAFETY APPLICATION") UNLESS THERE IS A SAFETY CONCEPT OR REDUNDANCY FEATURE CONSISTENT WITH THE ISO 26262 AUTOMOTIVE SAFETY STANDARD ("SAFETY DESIGN"). CUSTOMER SHALL, PRIOR TO USING OR DISTRIBUTING ANY SYSTEMS THAT INCORPORATE PRODUCTS, THOROUGHLY TEST SUCH SYSTEMS FOR SAFETY PURPOSES. USE OF PRODUCTS IN A SAFETY APPLICATION WITHOUT A SAFETY DESIGN IS FULLY AT THE RISK OF CUSTOMER, SUBJECT ONLY TO APPLICABLE LAWS AND REGULATIONS GOVERNING LIMITATIONS ON PRODUCT LIABILITY.

© Copyright 2015–2017 Xilinx, Inc. Xilinx, the Xilinx logo, Artix, ISE, Kintex, Spartan, Virtex, Vivado, Zynq, and other designated brands included herein are trademarks of Xilinx in the United States and other countries. PCI, PCIe and PCI Express are trademarks of PCI-SIG and used under license. AMBA and ARM are registered trademarks of ARM in the EU and other countries. Cortex is a trademark of ARM in the EU and other countries. All other trademarks are the property of their respective owners.